



INSTALLATION INSTRUCTIONS

DIRECT CONNECTION PRE-STAGE KIT

DODGE CHALLENGER SRT® HELLCAT REDEYE 6.2L HO

DODGE CHALLENGER SRT® DEMON 6.2L

PART NUMBER: 77072579AD



www.dperformance.com



TO PREVENT **SERIOUS INJURY** AND **PROPERTY DAMAGE**, YOU SHOULD READ, UNDERSTAND AND FOLLOW THE WARNINGS AND INSTRUCTIONS IN THIS MANUAL **PRIOR** TO INSTALLATION.
FOR ASSISTANCE CONTACT **DIRECT CONNECTION TECH HOTLINE 1-800-998-1110**



Bill of Materials

Part Description	Part Number	Service Parts	Quantity
Direct Connection Tuner – Challenger	FCA9100	Contact DC	1
180 Degree Thermostat	82215542	Yes, Mopar	1
Air Filter	05038820ACE-SP4	Contact DC	1
OBD2 Port Cover	MMOPC	Contact DC	1
CARB EO Label	EO Label	Contact DC	2
Instruction Sheet	K6864148AD	Online	1

Contents

Thermostat 3

 Removal..... 3

 Installation..... 3

Air Filter 4

 Removal..... 4

 Installation..... 4

Direct Connection Tuner - Challenger 5

 Security Gateway Module Update – Redeye & Demon Vehicles Only 5

 Updating the Direct Connection Tuner 5

 Installing Update Agent Software 5

 Updating the Device..... 5

 Tuner Mount Installation 5

 Cable Installation..... 5

 Main Menu 6

 Tuning..... 6

Dealer Installed Vehicle Option VIN Assignment 7

Capacities and Recommended Fluids Specifications 7

California Air Resources Board Executive Label..... 7

DISCLAIMER

WARNING: Before using this device, read the complete User Manual. Never attempt to alter this device. This device is not intended for your attention while driving – distracted driving may cause motor vehicle accidents, death, or serious injury. User ASSUMES ALL RESPONSIBILITY and LIABILITY FOR ANY CLAIMS arising from distracted driving while using this device or from altering it. To AGREE and continue, select “Yes” from the Direct Connection Tuner Initial Startup.

Thermostat

CAUTION: Do not operate an engine without a thermostat, except for servicing or testing.

- The Direct Connection thermostat starts to open nominally at 180°F (82°C) and is fully opened at 202°F (94°C).

Removal

WARNING: Do not loosen the radiator draincock with the cooling system hot and pressurized. Serious burns from the coolant can occur.

To remove the thermostat:

1. Drain the cooling system.
2. Remove the upper radiator hose (1) from the thermostat housing and position aside.
3. Remove the bolts (2), and remove the thermostat housing and thermostat.

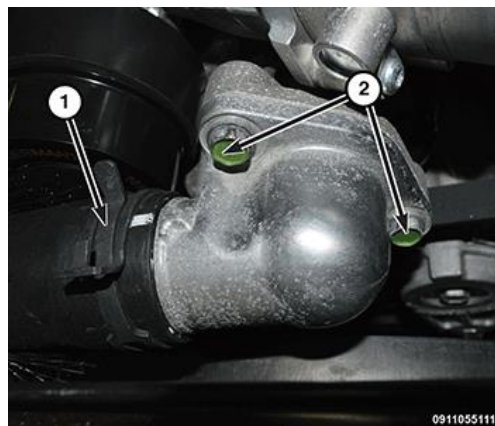

Installation

If installing a Redeye Stage 2 Kit concurrently, wait to install thermostat until after Stage 2 is installed for additional space when removing the supercharger belt.

To install the Direct Connection Thermostat:

1. Position the **NEW** thermostat (1) with the vent at the 12 o'clock position. Make sure that the gasket seal (2) is fully seated.

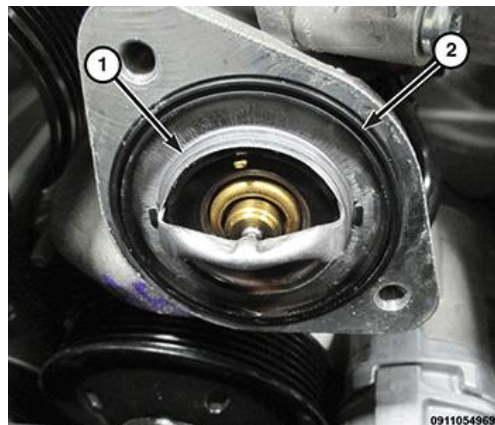

2. Install the thermostat housing and tighten the bolts (2) to **21 Ft. Lbs. (28 N-m)**
3. Install the radiator hose (1) on the thermostat housing.
4. Fill the cooling system. (See Service Manual for refill procedure)
Important: System must be free of air pockets, overheat may result.
5. Start and warm the engine. Check the cooling system for leaks.

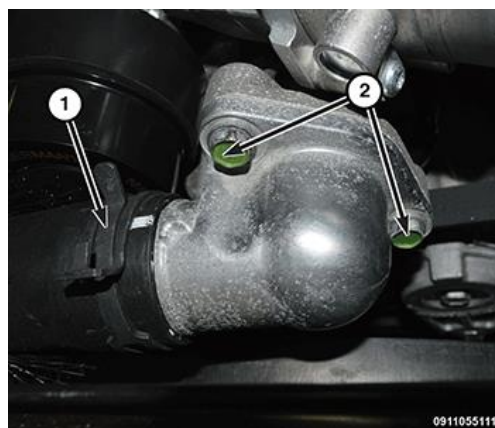

Air Filter

Removal

1. Disconnect and isolate the negative battery cable.
2. Loosen the clamps (1, 4) on the air cleaner air duct.
3. Disconnect the Inlet Air Temperature (IAT) sensor wire harness connector (3).
4. Move air cleaner air duct aside and free from obstruction.

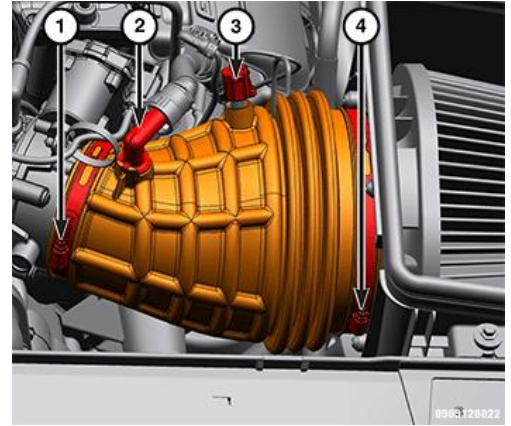

5. Remove the air cleaner element retaining screws (1).
6. Remove the air cleaner element from the housing.
7. Clean the inside of air cleaner housing before replacing element.

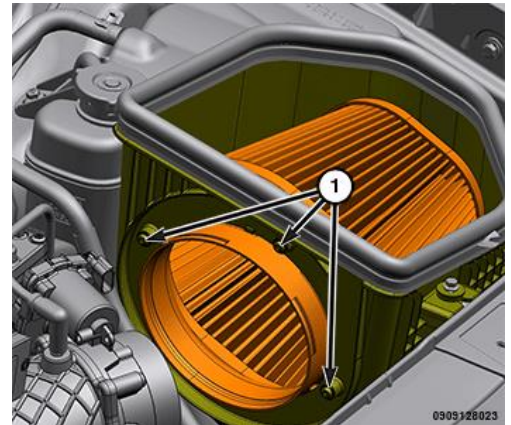

Installation

1. Install the **NEW** air cleaner element into the housing and securely tighten the retaining screws (1).
2. Install the air cleaner air duct and securely tighten the clamps (1, 4).
3. Connect the Inlet Air Temperature (IAT) sensor wire harness connector (3).
4. Connect the negative battery cable.

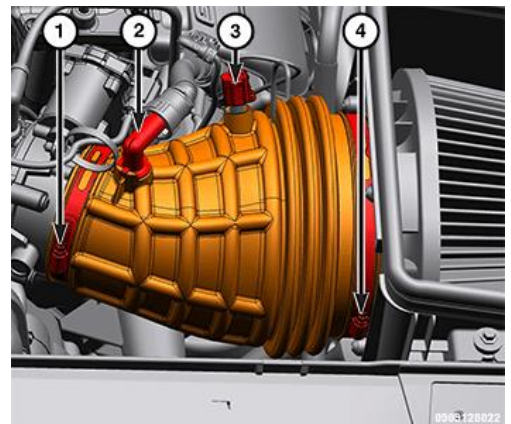
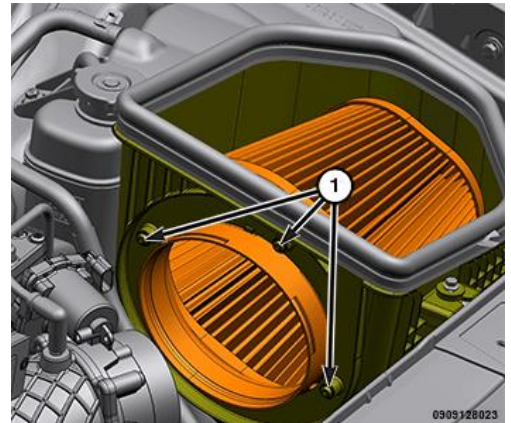

Direct Connection Tuner - Challenger

The Direct Connection Tuner will come pre-set with the correct calibration needed to properly run your new hardware. Plug in the device and follow the steps included within the Tuner box. Highlights are included below to get you started, however, make sure your device is updated to the latest software level. Review the Tuner Manual for directions on how to make sure your device is at the latest software level and for any additional detail not covered in these instructions.

Security Gateway Module Update – Redeye & Demon Vehicles Only

In order for all features of the Direct Connection Tuner to function properly, make sure your Security Gateway Module is flashed with calibration **68593431AB**. Redeye, Super Stock, and Demon Vehicles Only. See dealer to install.

NOTICE

It is necessary to complete the Security Gateway module update **BEFORE** connecting to the Direct Connection Tuner. Failure to do so will result in reduced functionality.

Updating the Direct Connection Tuner

Installing Update Agent Software

To begin using the Direct Connection Tuner, please follow the Tuner Update Sequence below:

1. Connect the device to a computer using the supplied USB cable.
2. Browse the file explorer and locate the Tuner drive.
3. Double-click the drive and open the folder labeled “Updater”.
4. Double click the Mac or Windows folder based on the computer type
5. Double the Installer Application
6. Click RUN, then review and accept the license agreement terms, then INSTALL
7. Select CLOSE after installation is complete.
8. Double-click the Update Agent desktop icon and fill out the registration form

Updating the Device

1. Open the Update Agent software
2. Connect Tuner device to the computer with the supplied USB Cable
3. Click the “UPDATE” button – process will start and finish automatically

Tuner Mount Installation

Follow the steps outlined within the angled mount installation instructions found in the Tuner Packaging.

Cable Installation

1. Plug the OBDII connector into the vehicle port.
2. Route the HDMI end up the driver side dash. (You may remove the side panel for easier routing. Leave exposed until after the display is installed.)

NOTE: Once paired to a vehicle, the vehicle’s VIN is stored and the device can no longer be used on any other vehicle.



Main Menu

Displays each of the menu options available.

MENU OPTIONS	BASIC DESCRIPTIONS
Tuning	Choose from standard tuning options
Performance Tests	Quickly and easily test your new tunes & performance
Settings	Adjust device settings to better fit your needs
Gauges	Monitor and record your vehicle performance
Diagnostics	Diagnose and clear trouble codes
Stage Code	Access the Stage Code Manager

Tuning

1. Install a battery charger to the vehicle to maintain constant battery voltage, otherwise communication with onboard ECUs may be lost and ECUs can be damaged during Tuning.
2. Select “**Settings**” from the **Main Menu**, scroll down to “Check for Updates” then check the device for any available software updates.
A Wi-Fi connection is necessary. If updates are available, the device will provide the option to perform the update.

NOTICE A WLAN internet connection is preferred.

If it is necessary to connect via a Mobile Hotspot, Hotspot names should not contain any spaces or special characters, otherwise it may not be possible to achieve a suitable connection with the DC Tuner.

3. Return to the Main Menu and Select the **Tuning** icon.
4. Turn the vehicle ignition to ON. Engine must remain OFF. Select “Tune Vehicle”. Follow the on-screen instructions.
5. Once your vehicle has been successfully tuned, press Continue to return to the **Main Menu**.

NOTICE

Do not remove or bump the OBD-II connector during any programming sequence. If you do, the vehicle may not start.

WARNING: Do not program the vehicle while parked in unsafe locations including in heavy traffic or places without cell phone service and the internet (if possible).

Main Menu

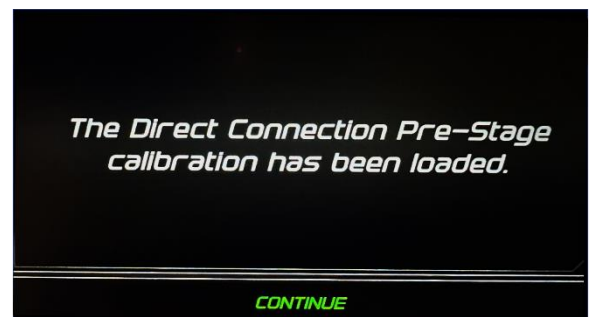
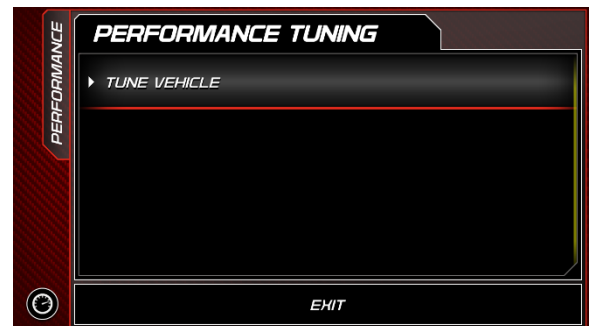
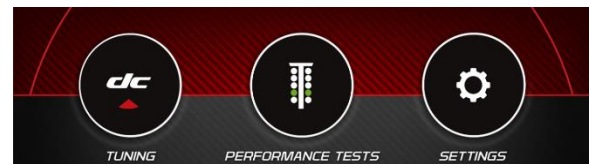
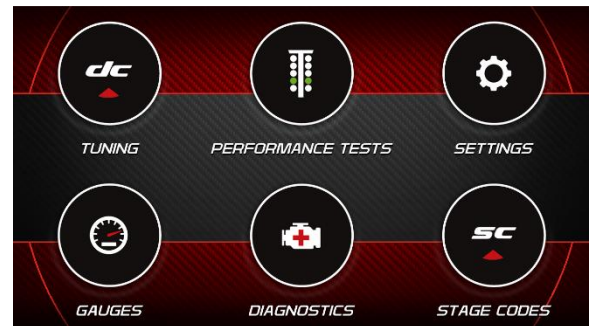

Dealer Installed Vehicle Option VIN Assignment

After installing the stage kit on the vehicle, your Dodge Power Broker dealership can assign the Dealer Installed Vehicle Option to the vehicle VIN. See your Power Broker dealer to assign the appropriate option code associated with the stage kit that has been installed on your vehicle.

Vehicle Option Code	Application
6TQ	Redeye Pre-Stage Kit
6TR	Redeye Stage 1 Kit
6TS	Redeye Stage 2 Kit

NOTICE

It is advised to add Dealer Installed Vehicle Options after installing all stage kits to minimize communication interruptions with vehicle modules. 2018 Challenger Demon and Super Stock vehicles should use the same Option Codes as Redeye vehicles.

Capacities and Recommended Fluids Specifications

Description	Capacities	Type	Part Number
Cooling System *	15.2 Quarts / 14.4 Liters	We recommend you only use MOPAR Antifreeze/Coolant 10 Year/150,000 Mile Formula OAT coolant conforming to MS.90032.	68163848AB

* Includes heater and coolant reservoir filled to MAX level.

NOTICE

California Air Resources Board Executive Label

All models have a VECI Label. Chrysler permanently attaches the label in the engine compartment. It cannot be removed without defacing information and destroying the label.

Place the CARB E.O. Label Supplied in the Kit directly next to the VECI label. **This product information label is required to aid in passing the California Smog Check program.**

NOTICE

If you are a 2018 Challenger Demon owner and your kit did NOT come with D-265-72 EO Labels, you MUST contact the DC Tech Hotline to have a D-265-72 EO label sent to you to meet CARB Installation Requirements. Either D-265-71 and D-265-72 EO Labels are OK to use on Challenger Redeye and Super Stock vehicles.

The label contains the Executive Order Number for the Direct Connection Challenger Redeye Pre-Stage Kit.



MOPAR®
26311 Lawrence Ave
Center Line, MI 48015
888-528-HEMI

The following kit part number
has been issued under
C.A.R.B. E.O.
D-265-72
Redeye Pre-Stage Kit
77072579AD

THIS PAGE INTENTIONALLY LEFT BLANK