



DECKED Storage System



Installation Instructions: DR6 & DR7

RAM 1500

(2019-CURRENT, NEW BODY STYLE ONLY)

TOOLS REQUIRED

- Adjustable wrench (that opens to about 1")
- 7/16" deep socket
- 1/2" open end wrench
- 7/32" Allen wrench
- #2 Phillip screwdriver
- 1/2" drill bit
- 3/8" socket

Watch short installation videos at www.decked.com/video | Register your system at www.decked.com/warranty

FOLLOW US:      @DECKEDUSA | #DECKEDUSA

VERSION 4.1

DECKED.COM | 208.806.0251

CONTENTS

DECKED carton

- LEFT/DRIVER deck half - 1
- RIGHT/PASSENGER deck half - 1
- Center vert - 1
- Drawer - 2
- Cabside ammo can - 2
- Tailgate side ammo can - 2
- Ammo can lid - 4
- Ammo can window - 2
- C-channel - 2
- Ruler - 1
- Hardware box - 1

Hardware box - unbagged components

(inside DECKED carton):

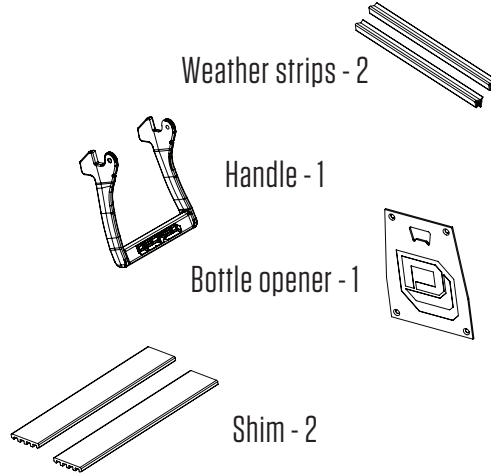

HARDWARE box - bagged components

- C-CHANNELS C - 1
- BOLT 1 FS (B1) - 1
- CS AMMO CANS - 1
- J6C - 4
- DRAWER 1 - 1
- DRAWER 3 - 1
- HANDLE C - 1
- WHEELS C - 1
- FINAL FS - 1
- PREP-EXTRA - 1
- BED TAPE - 1
- FOAM SEAL - 1

ASSEMBLY OVERVIEW

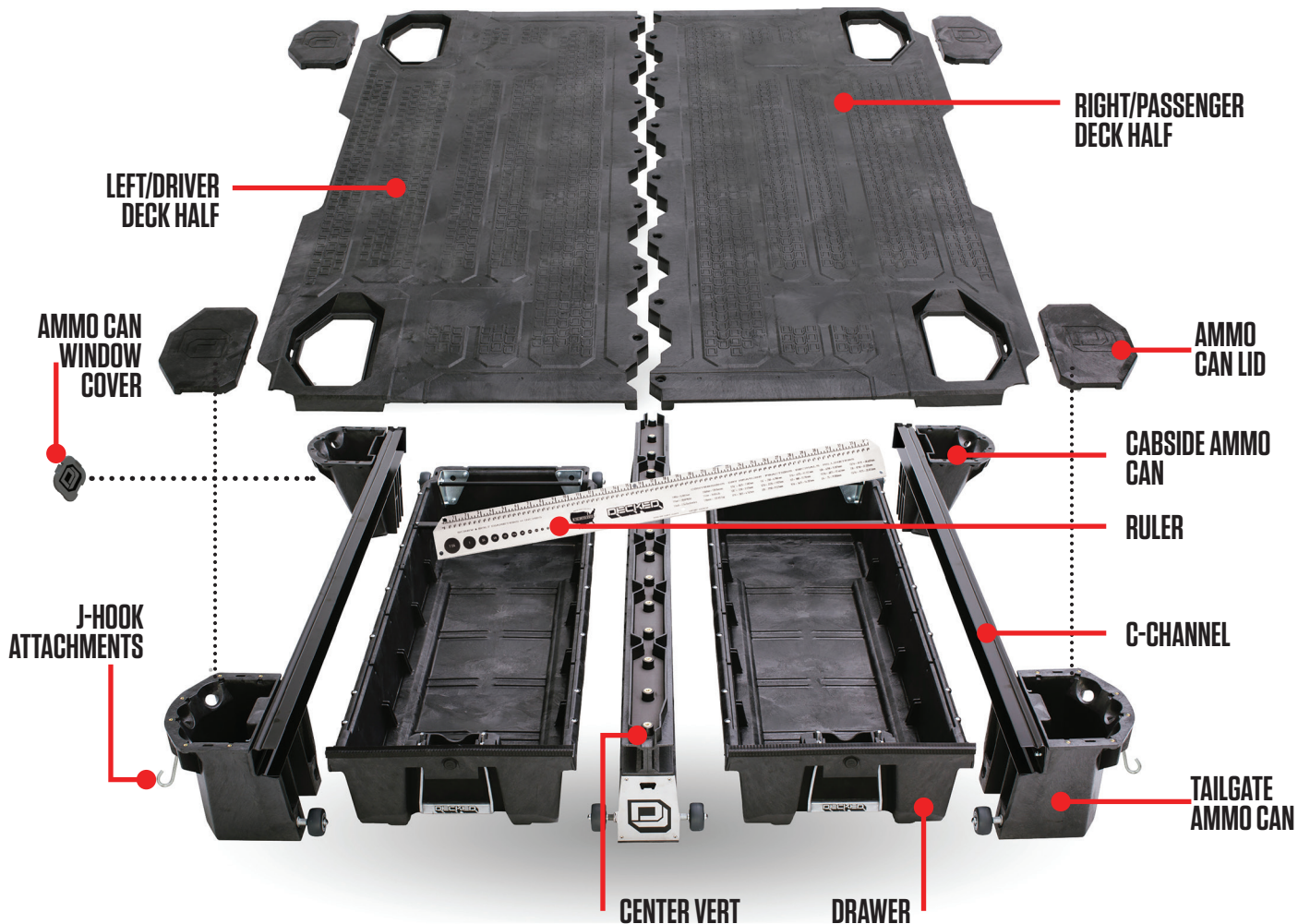

▼ HEY! TORQUE BOY: READ BEFORE YOU INSTALL DECKED ▼

1. **DON'T** be an idiot read the instructions.
2. **DON'T** over tighten bolts, get em' hand-tight.
3. **DON'T** use power tools.
4. If you don't follow directions and *do* use power tools:
 - 1). Set clutch at a very low setting. 2). If you blow it, see NOTE.*
5. **DON'T** over tighten J-hooks during installation. Make 'em good and snug enough to keep the system from moving in the bed.
6. Nice job if you're still reading .

NOTE* Two extra threaded inserts are included in **BAG PREP-EXTRA**. That's all you get. The inserts will replace any stripped inserts in the tailgate ammo cans, but NOT THE CENTER VERT, so hand tighten until snug only! You can also screw the inserts back in if dislocated. There is a straight screwdriver slot on the underside of the insert.

TAILGATE ammo cans have wide bottoms; **CABSIDE** ammo cans have narrow bottoms.

NOTE: You will need a buddy to help with exactly two steps, not including draining the sixpack or snapping pics of you posing.

Prevent abusive, expletive-filled language, watch our detailed installation video or give us a call. We're happy to help!

208.806.0251 | DECKED.COM/INSTALLVIDEO

AMMO CAN DRAIN HOLES

(TO DRILL OR NOT TO DRILL.)

- **Do you use a tonneau or shell over your DECKED system?**

There is no need to drill holes.

- **Does your DECKED system live outside?**

The ammo cans will get water in them. You'll need to drill holes in the ammo cans.

There are two dimples in the bottom of each ammo can. Drill a 1/2" hole at each dimple. A smaller hole will get clogged.



PREPARE BED: INSTALL BED TAPE

NOTE: Got a spray-in bed liner, Bedrug or mat? You won't need this bed tape. Otherwise, follow the directions below depending on your bed length to protect your bed paint.

DR6 - 5'7" BED:

- 1) Cut the tape into the following lengths for the 5'7" bed:
 - 12" long - 2 strips
 - 14" long - 4 strips
 - 61" long - 2 strips
- 2) Referencing the image **DR6** shown to the right:
 - a) Use isopropyl alcohol to clean the top surfaces of the floor beads where the tape will be located.
 - b) Remove film from tape to expose the adhesive surface.
 - c) Align the tape at the ends of the designated floor beads, center the tape on the flat, top surfaces and apply with pressure.

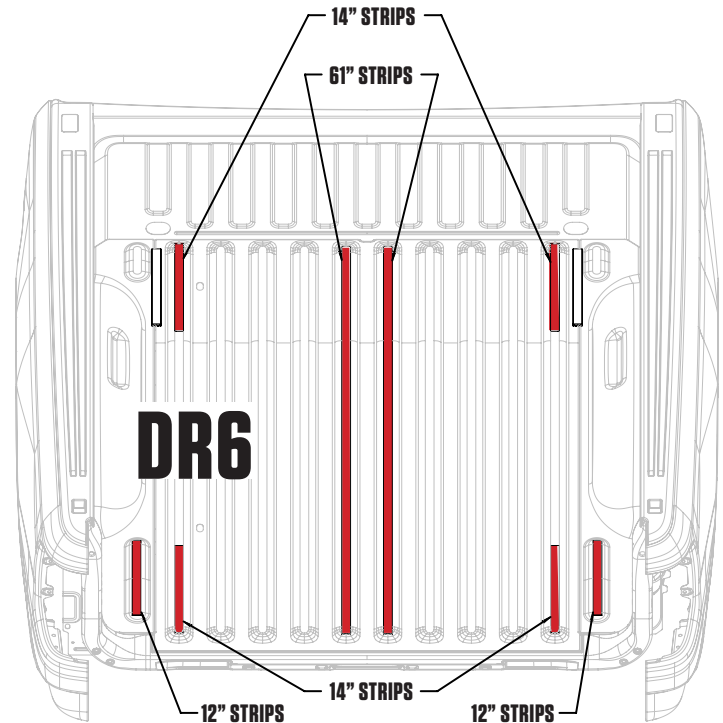

DR7 - 6'4" BED:

- 1) Cut the tape into the following lengths for the 6'4" bed:
 - 12" long - 2 strips
 - 14" long - 4 strips
 - 30" long - 4 strips
- 2) Referencing the image **DR7** shown to the right:
 - a) Use isopropyl alcohol to clean the top surfaces of the floor beads where the tape will be located.
 - b) Remove film from tape to expose the adhesive surface.
 - c) Align the tape at the ends of the designated floor beads, center the tape on the flat, top surfaces and apply with pressure.

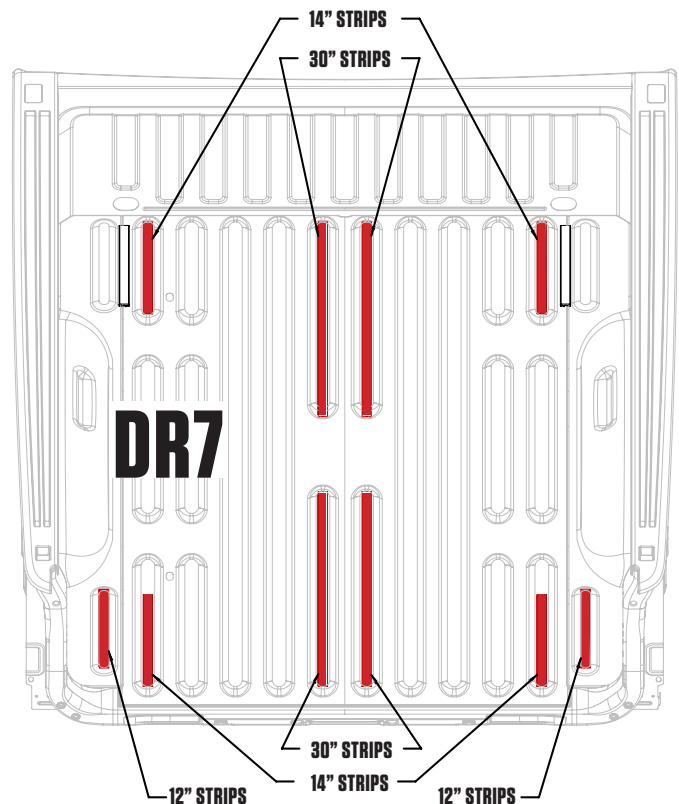

PREPARE BED: INSTALL SHIMS

- There are **2 SHIMS** provided:
- Using the information in the respective circular detail views:
 - a) Clean the surfaces thoroughly where the shims will be located (isopropyl alcohol is recommended).
 - b) Remove the layer of tape on the bottom of the shim to expose the adhesive surface.
 - c) Place the shim and apply with pressure.

NOTE: Repeat DETAIL A passenger side.

DETAIL A

Center shim between floor beads shown.
Place shim 2" from cabside panel (blue).
Repeat on passenger side.

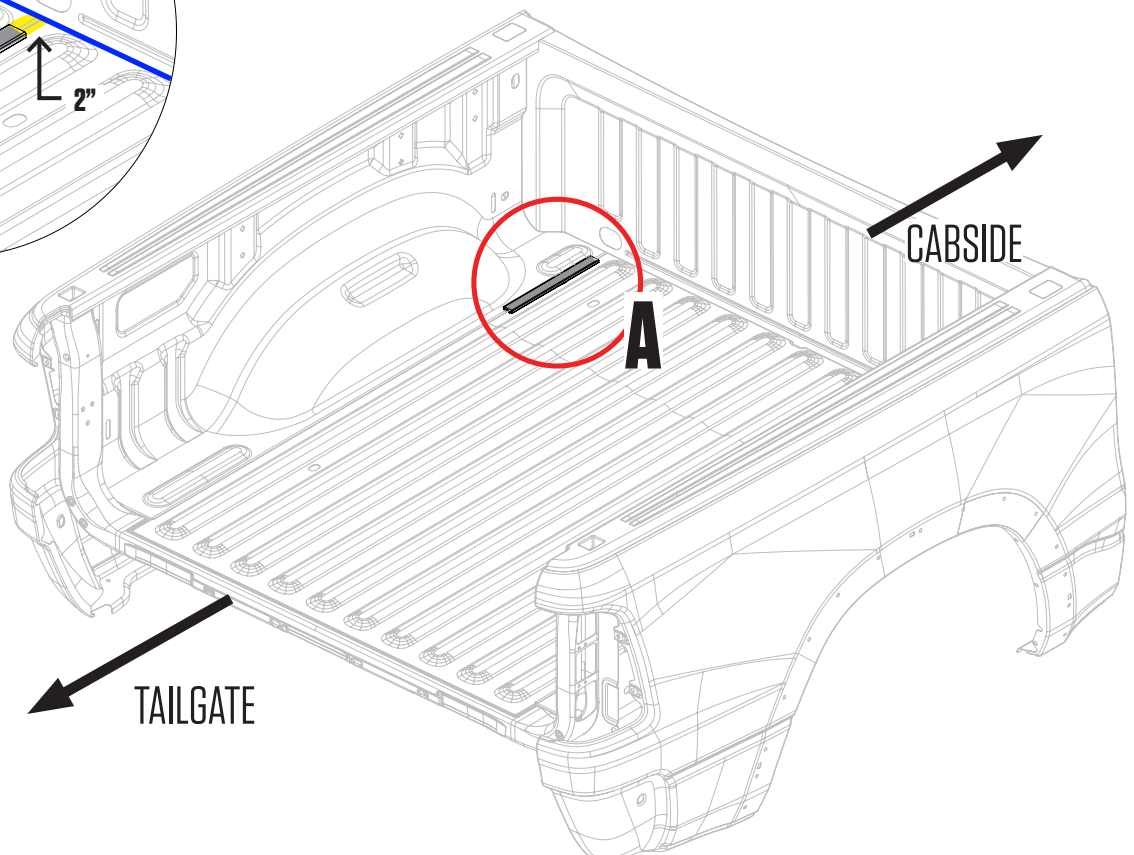
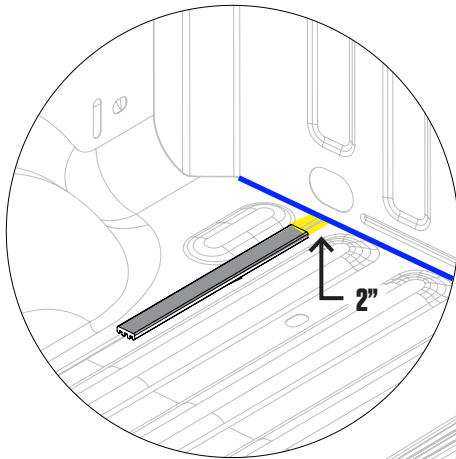

ASSEMBLY: DRIVER'S SIDE DECK

(LET'S DO THIS!)

- There are three pre-installed gaskets – one on the center vert, one on each underside of the decks where they rest on the center vert. Do yours look weird? See them here: DECKED.COM/GASKETS
- Place C-channel on the **inside** ledges of a cabside ammo can and a tailgate ammo can.
- The end of the C-channel with the endplate must rest on the cabside ammo can.
- Verify that the tailgate ammo can's axle is closest to the tailgate; if not, grab the other tailgate ammo can.
- Loosely bolt C-channel to the two ammo cans with (4) nylon washers on the (4) bolts. **Make sure the bolt head is on the C-channel side, not inside the ammo can; BAG C-CHANNELS C.** Don't tighten yet.
- Line up the driver's side deck (sticker on end of deck panel indicates LEFT/DRIVER) on top of the C-channel/ammo can assembly and the center vert bosses. **NOTE: Tailgate side of the center vert has an axle installed; the center vert and ammo can axles must be on the tailgate end (not cabside end) of the assembly.**
- Bolt the deck to the ammo cans; **BAG B1** for the tailgate ammo can, **BAG CS AMMO CAN** for the cabside ammo can.
- **Now go back and tighten the loose bolts connecting the ammo cans to the C-channel.**
- Bolt the deck to the center vert; **BAG B1: Do not use power tools!**
- Grab your buddy to help you lift the assembly into the driver side of the truck bed.

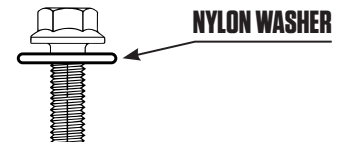

DRIVER SIDE DECK HALF

RECOMMENDED TORQUE: Bolts in labeled bags **C-CHANNELS C**, **CS AMMO CAN** and **B1** - 27 in-lb.

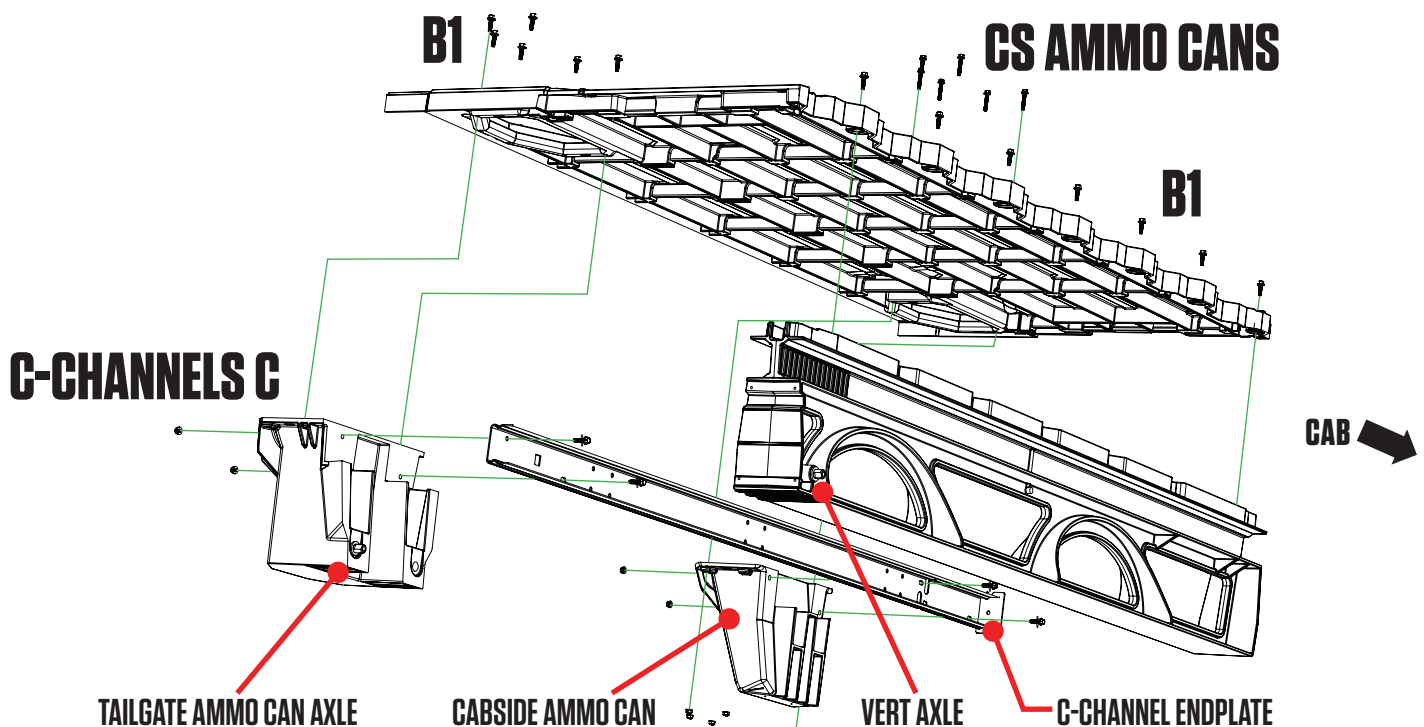

ASSEMBLY: PASSENGER'S SIDE DECK

(NOW YOU'RE ACTUALLY GETTING SOMEWHERE!)

- Place C-channel on the **inside** ledges of a cabside ammo can and a tailgate ammo can.
- The end of the C-channel with the endplate must rest on the cabside ammo can.
- You should have the correct tailgate ammo can for this step. The axle will be on the tailgate side of the system. If not, swap the tailgate ammo cans now.
- Loosely bolt C-channel to the two ammo cans with (4) nylon washers on the (4) bolts. **Make sure the bolt head is on the C-channel side, not inside the ammo can; BAG C-CHANNELS C.** Don't tighten yet.
- Line up the passenger's side deck (sticker on end of deck panel indicates RIGHT/PASSENGER) on top of the C-channel/ammo can assembly.
- Bolt the deck to the ammo cans; **BAG B1** for the tailgate ammo can, **BAG CS AMMO CAN** for the cabside ammo can.
- **Now go back and tighten the loose bolts connecting the ammo cans to the C-channel.**
- Grab your buddy to help you lift the assembly into the passenger side of the truck bed.

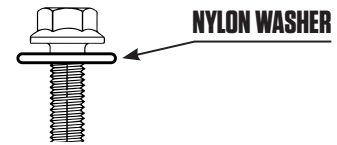

PASSENGER SIDE DECK HALF

RECOMMENDED TORQUE: Bolts in labeled bags **C-CHANNELS C**, **CS AMMO CAN** and **B1** - 27 in-lb.

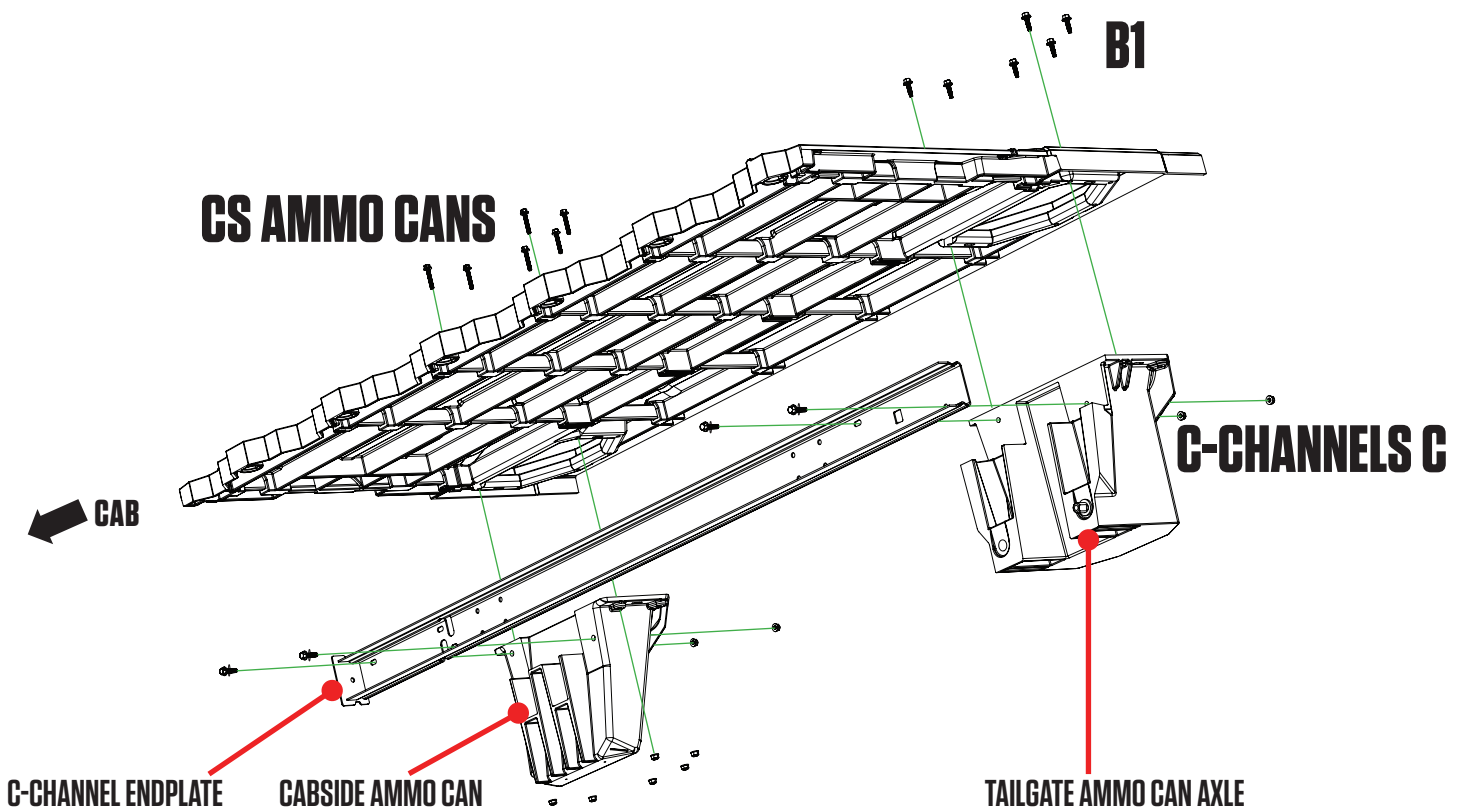

INSTALL: PASSENGER'S SIDE DECK HALF

(OK, FINE, PAT YOURSELF ON THE BACK)

- Seat passenger side deck on the upstanding vert bosses.
 - Bolt the passenger side deck half to the center vert; **BAG B1**. Make sure all bolts connecting the deck to the center vert are snug, **but no power tools**.
 - Insert the J-hook through the **center** hole on the passenger side tailgate ammo can and loop J-hook through tie down or mounting bracket in bed. Assemble with black spherical washer, flat washer and nut; **BAG J6C**. Don't tighten yet. If you do, you won't be able to center the system properly in your bed.
 - Insert the J-hook through **center** hole on the passenger side cabside ammo can and loop J-hook through tie down or mounting bracket in bed. Assemble with black spherical washer, flat washer and nut; **BAG J6C**. Don't tighten yet.
- IMPORTANT: Leave all J-hook nuts loose until entire deck is in place.**

RECOMMENDED TORQUE:
Bolts in labeled bag B1 - 27 in-lb.

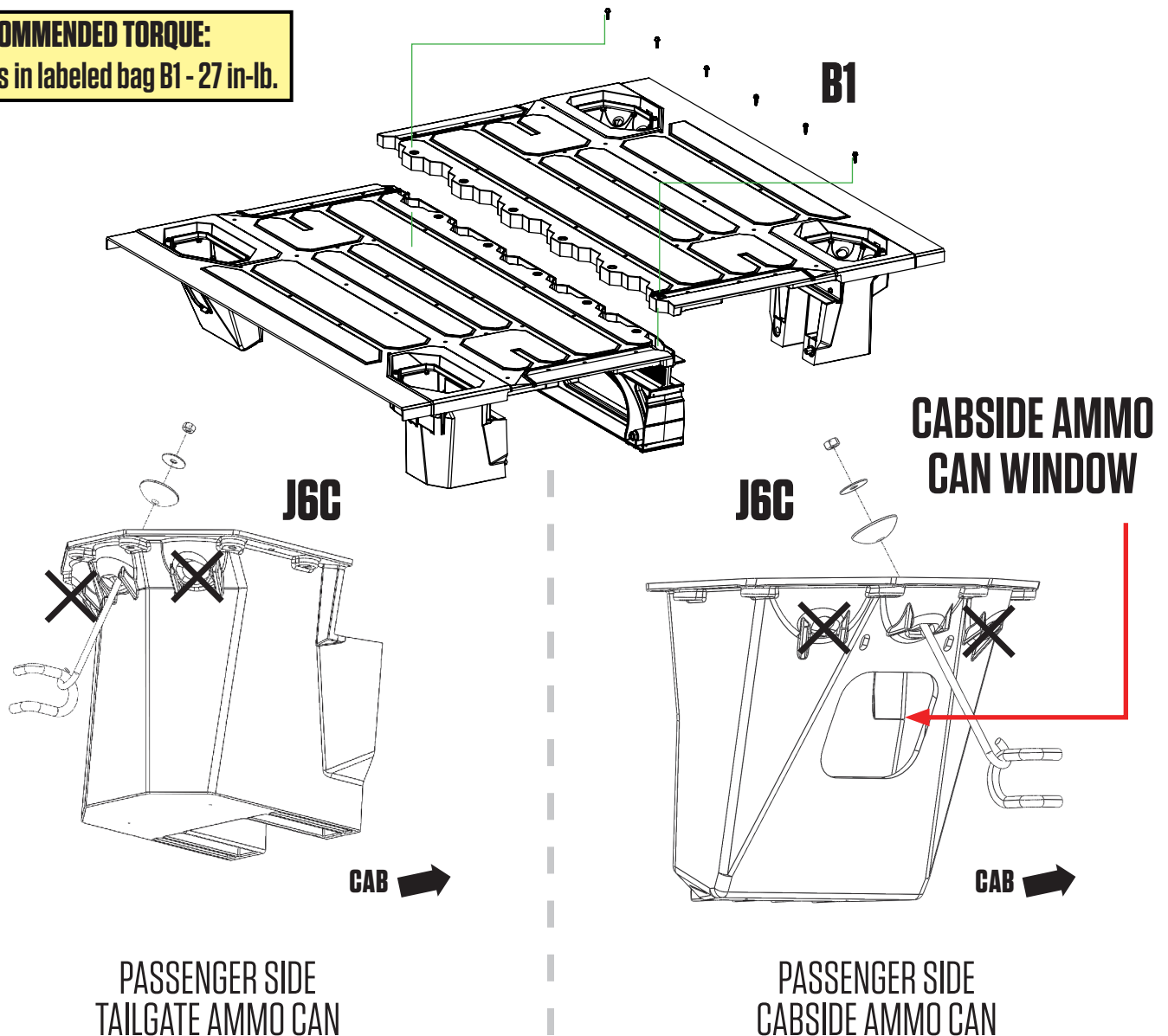

INSTALL: DRIVER'S SIDE DECK HALF

- Insert the J-hook through the **center** hole on the driver side cabside ammo can and loop J-hook through tie down or mounting bracket in bed. Assemble with black spherical washer, flat washer and nut; **BAG J6C**. Don't tighten yet.
- Insert the J-hook through the **center** hole on the driver side tailgate ammo can and loop J-hook through tie down or mounting bracket in bed. Assemble with black spherical washer, flat washer and nut; **BAG J6C**. Don't tighten yet.

IMPORTANT: Leave all J-hook nuts loose until entire deck is in place.

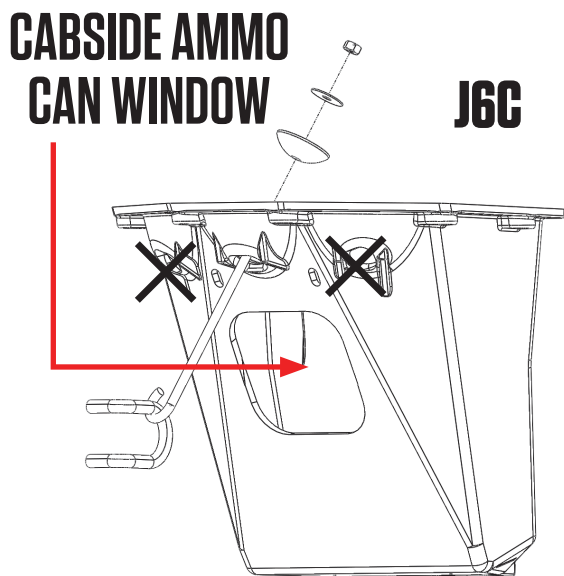

← CAB

DRIVER SIDE
CABSIDE AMMO CAN

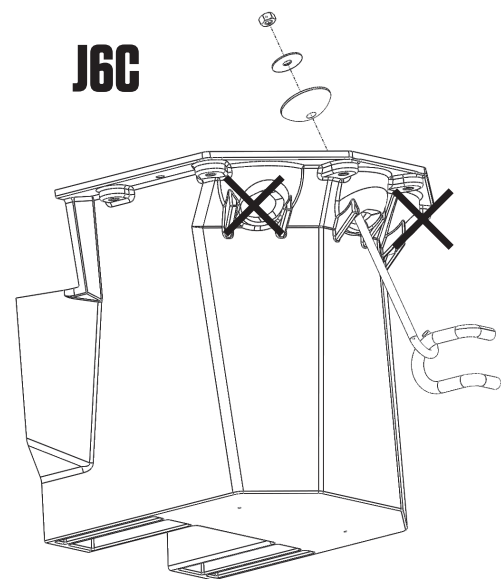

← CAB

DRIVER SIDE
TAILGATE AMMO CAN

INSTALL: CABSIDE FOAM SEAL

NOTE: You won't need this seal if you have a tonneau cover or camper shell.

- Loosen all four J-hooks if you jumped the gun and tightened them already.
- Standing at the tailgate end of the bed, grab deck panels and pull the whole system as far toward the tailgate end as possible.
- Climb up on deck and place foam seal in the gap between the deck and cabside panel with the adhesive side facing the deck, not the truck, as shown in **DETAIL A**. The top edge of foam seal should be level with the top edge of the deck. **NOTE: Depending on how the seal is unrolled, the paper carrier may not end up on the adhesive side of the seal. Check for stickiness in determining the adhesive side of the seal.**
- Slowly stick the foam seal across the deck panel and remove the paper carrier as you go.
- Once foam seal is in place, stand at tailgate end of bed and push the DECKED system as far towards the cab as possible to compress the seal.

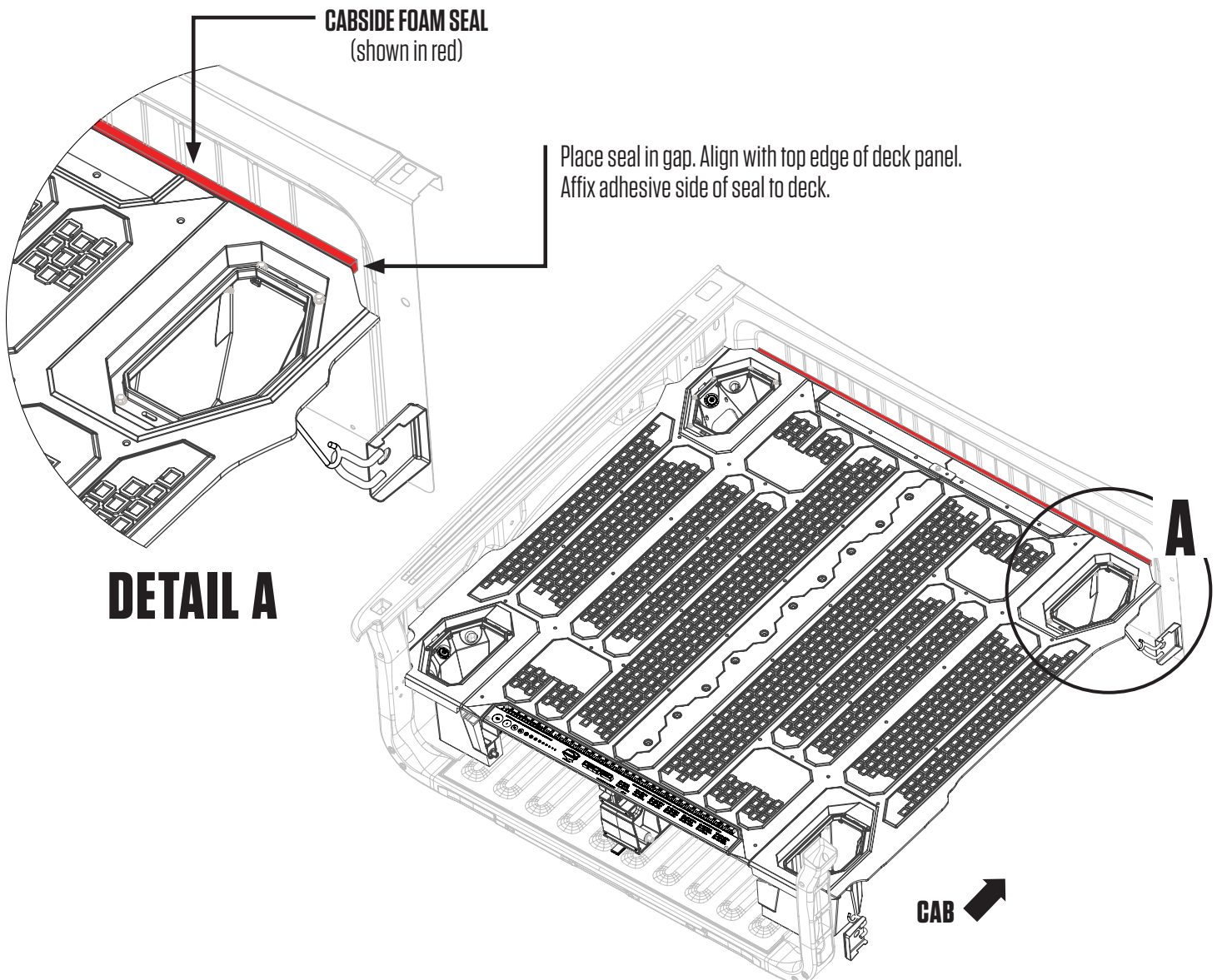

DRAWERS: BRACKETS + WHEELS

(SO EASY A CHIMPANZEE CAN DO IT)

- Each drawer has a left and a right bracket. Bolt the brackets into place via bottom two holes in bracket with 3/4" length bolts. Use the 2" length bolt for the upper cabside wall hole in bracket; **BAG DRAWER 1**.
- Install a tube brace in each drawer with two 3/4" length bolts; **BAG DRAWER 1**, **BAG DRAWER 3**.
- Attach wheels onto the drawer brackets with a 7/32" hex wrench; **BAG WHEELS C**.

RECOMMENDED TORQUE:

Bolts in labeled bags **DRAWER 1** and **DRAWER 3** - 27 in-lb.

Bolts in labeled bag **WHEELS C** - 90 in-lb.

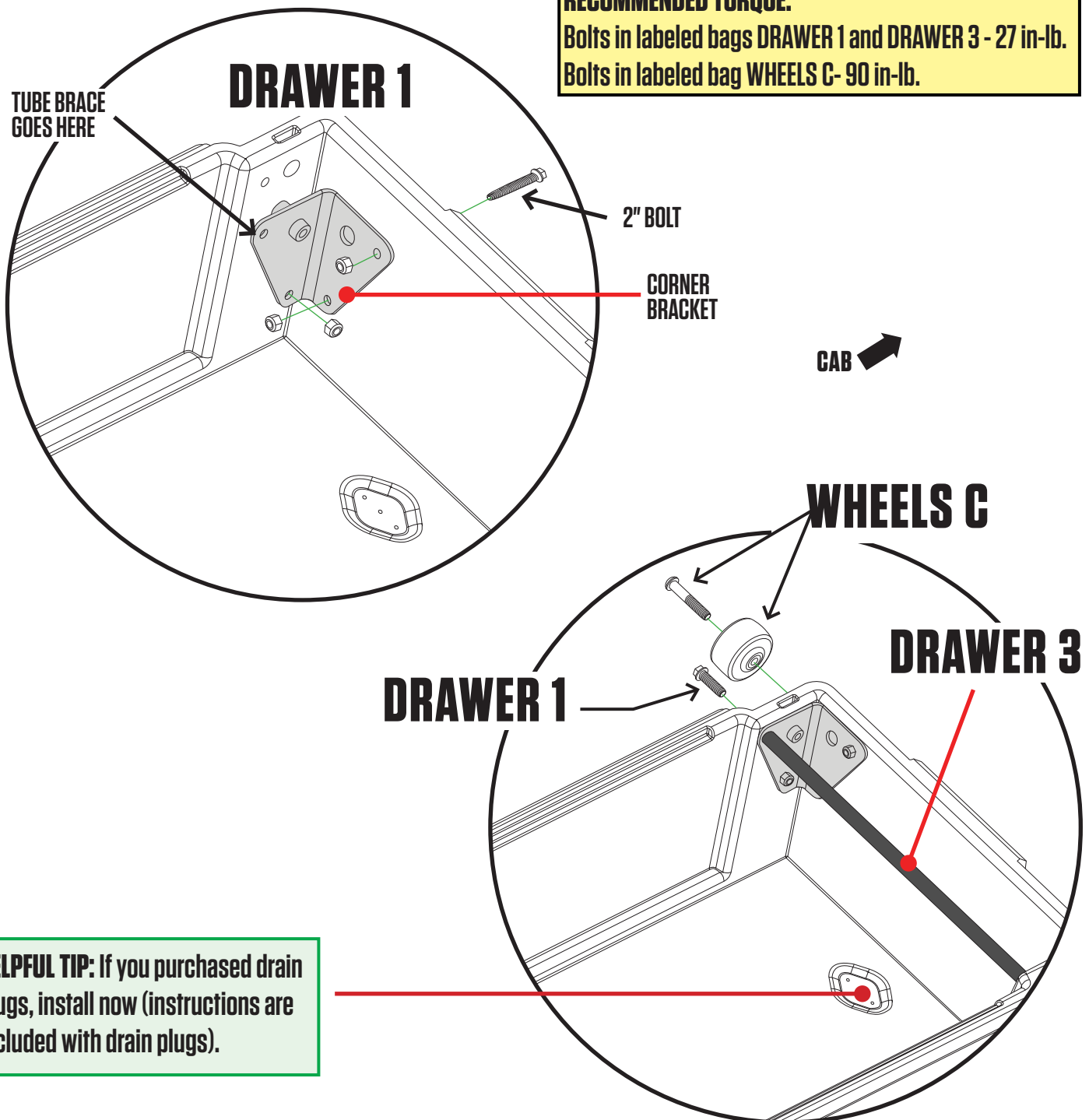

INSTALL: DRAWER HANDLES

- One drawer handle assembly needs to be installed.
- Save yourself the headache, watch this short installation video: DECKED.com/videohandle.
- From the **underside** of drawer, place the springs into the cavities on either side of the handle slots, red spring=right spring; **BAG HANDLE C**. **NOTE: Each spring arm should point inward, not outward.**
- Install a clevis pin through each outside drawer hole and through spring; **BAG HANDLE C**.
- With DECKED logo facing outward, insert the handle ends behind the spring arms. Rotate the arms of the handle toward the clevis pins, pulling the spring arm downward. When the handle hole is lined up with the clevis pin, push the pin through the handle hole and through the inside drawer hole. Repeat on the other side of the handle.
- Install a hair pin through the clevis pin; **BAG HANDLE C**.

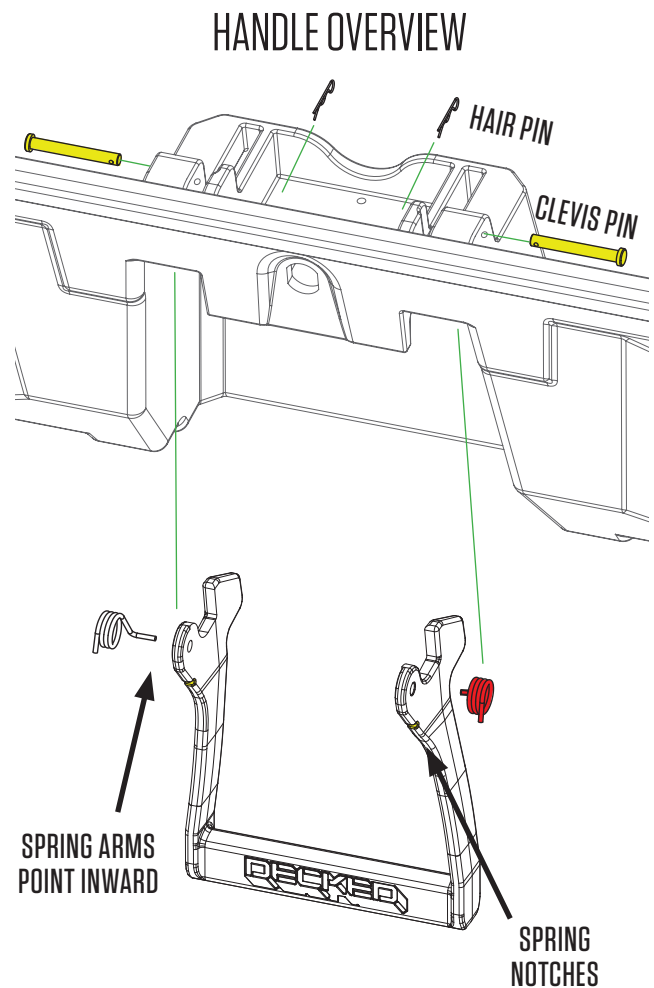
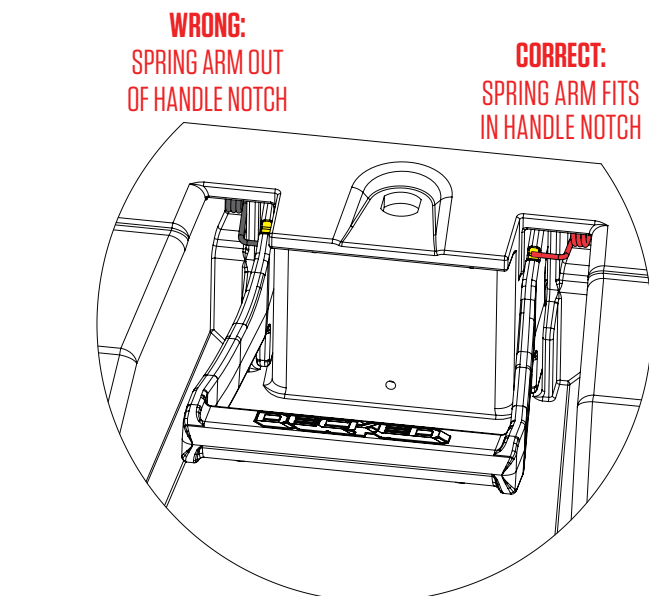
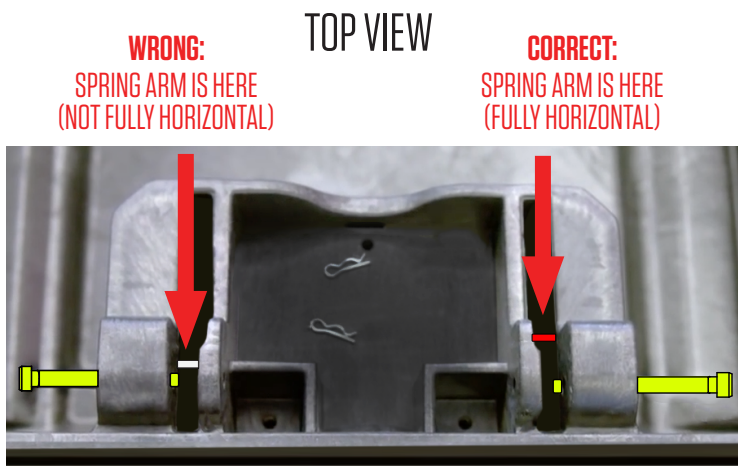

HELPFUL TIP: MAKE SURE SPRINGS HAVE THE LONG ARM HORIZONTAL AND SHORT LEG VERTICAL BEFORE INSERTING HANDLE



INSTALL: DRAWERS

(HOPEFULLY YOU'RE STILL WEARING YOURS.)

- Save yourself the headache, watch this short installation video: [DECKED.com/videtailgatewheels](https://www.decked.com/videtailgatewheels).
- Install the drawer by sliding wheels into their two channels (C-channel and center vert), and slide drawer all the way forward until closed.
- Install the remaining tailgate side wheels onto their axles; **BAG WHEELS C**.

NOTE: Placing a spacer under the drawer to raise it into position makes this easier (ammo can lids work well, or a small piece of 2x2 or 2x4 is even better).

- Install the weather strips on the tailgate side drawer edge: With the weatherstrip wiper facing cabside, line up one end with the side of the drawer and place on the top drawer edge, firmly pressing down on the weatherstrip as you move along the drawer edge.

NOTE: Facing the weather stripping the wrong way will funnel water into drawer: BAD!

RECOMMENDED TORQUE: Bolts in labeled bag WHEELS - 90 in-lb.

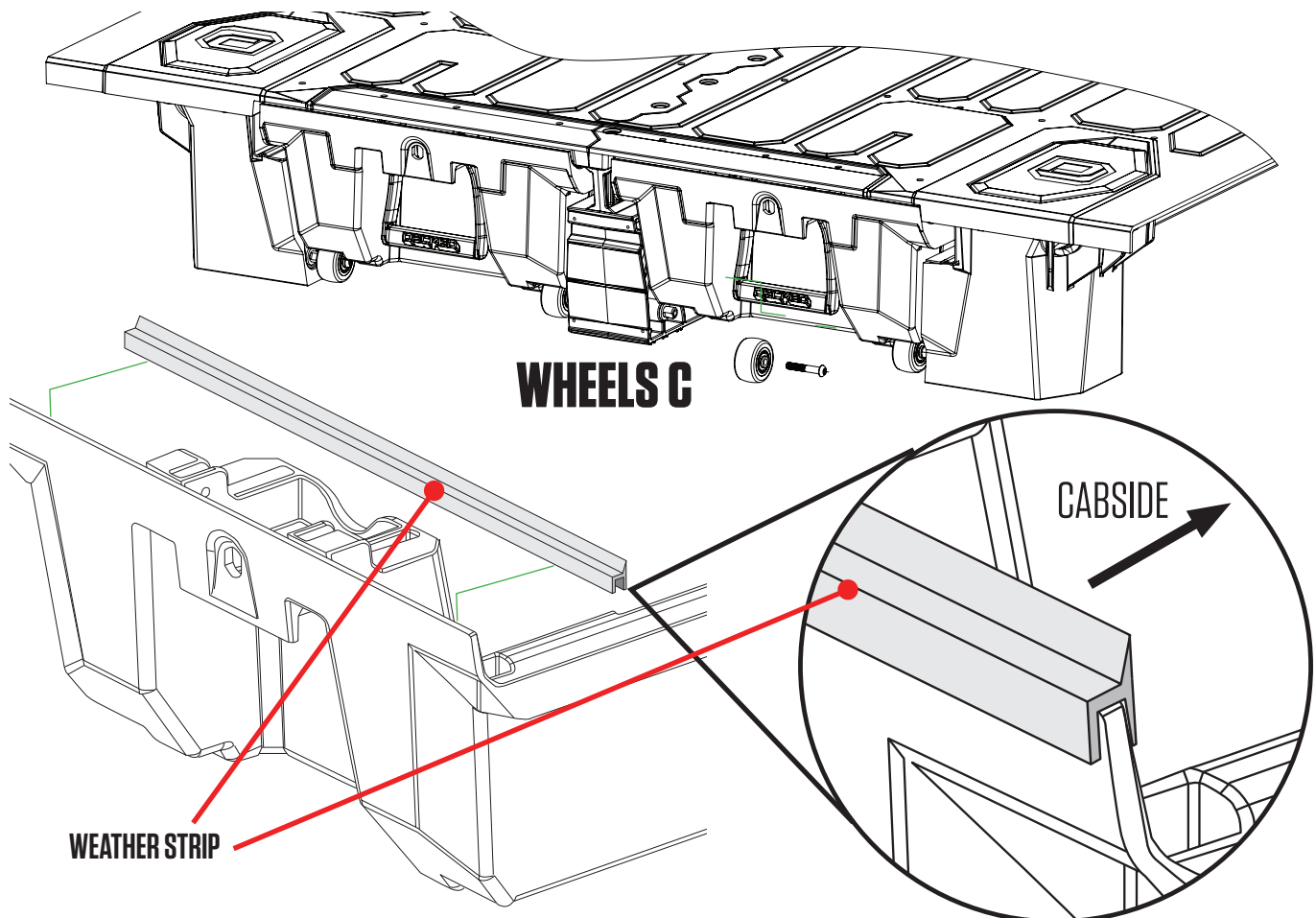

INSTALL: THE FUN STUFF

(PARTY TIME!)

MAKE SURE THE CENTER VERT IS IN THE CENTER OF YOUR BED; the gaps on either sidewall may not be equal because the world isn't perfect and neither is your truck bed.

- Alternately and gradually tighten all J-hooks to ensure DECKED is centered and secure. Recommended torque: Nuts in labeled bags J6 - 10 in-lb. **Do not tighten one side of J-hooks all the way in one step. DO NOT OVERTIGHTEN J-HOOKS!**

NOTE: If the DECKED system is noticeably "crowned", the J-hooks are too tight.

- Install the window covers in the cabside ammo cans (from inside the ammo can).

CAUTION: The following are small gauge screws – light, hand-tightening is all that is required.

- Center and screw on the ruler/edge guard; **BAG FINAL FS.**
- Screw on the bottle opener; **BAG FINAL FS.**
- Install lock core plugs; **BAG FINAL FS**, or install locks if purchased.

IMPORTANT: Grab your favorite beverage, crack 'er open in the bottle opener and toast your truck. You did it. Immediately post a photo of your significant other, child or canine (in no order of significance) appreciating your accomplishment. Add hashtag #DECKEDUSA | @DECKEDUSA.

RECOMMENDED TORQUE: Nuts for J-hooks in labeled bags J6C - 10 in-lb.

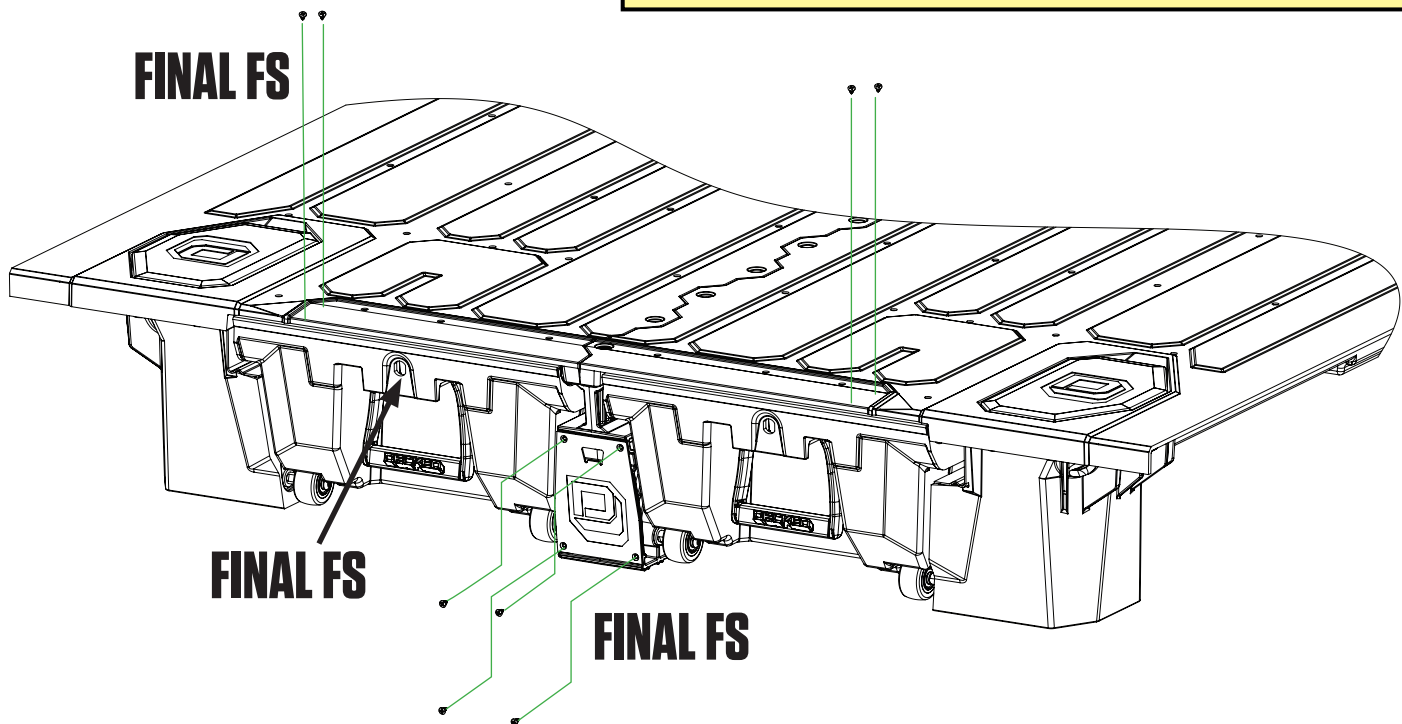

#DECKEDUSA | @DECKEDUSA

DECKED 3-YEAR LIMITED WARRANTY

(a.k.a. LEGAL MUMBO JUMBO)

LIKE YOUR HIGH SCHOOL GUIDANCE COUNSELOR USED TO SAY, "HELP ME, HELP YOU". **REGISTER YOUR PRODUCT!** IT'S QUICK, IT'S SECURE, AND IT'S THE BEST WAY TO HELP US HELP YOU IN THE RARE EVENT THAT YOUR ACTS OF AWESOMENESS LEAD TO A WARRANTY ISSUE. PLUS, AS AN ADDED BONUS, YOU WILL BE THE FIRST TO KNOW OF PRODUCT IMPROVEMENTS OR ISSUES SPECIFIC TO YOUR MODEL. GO TO **DECKED.COM/REGISTER**

DECKED LLC warrants to the original purchaser of this product that the product will be free from manufacturing defects in workmanship and materials for a period of three (3) years from the date of the original purchase. If within three (3) years from the original date of purchase this product fails due to defect in materials or workmanship, DECKED LLC will replace any defective part at its option.

The original purchaser must contact the DECKED LLC customer service team and provide a description of the defective part, including digital pictures if requested, with the original purchase documentation as validation of warranty coverage or have previously activated their warranty online.

This warranty DOES NOT cover or apply to:

- Damage to the product due to misuse, mishandling and abuse.
- Products not used in accordance with the manufacturer's instructions or recommendations.
- Product not assembled or installed according to manufacturer's instructions.
- Normal wear and tear.
- Undeclared damage to the system during shipping, acts of God. In addition, consequential damage and incidental damages (including lost time) such as damage to persons or property are not covered under this warranty.

(This space reserved for crayon drawings, coffee stains or ketchup spills.)

#DECKEDUSA | @DECKEDUSA