

# INSTRUCTION SHEET

## HOLLEY CARBURETOR MODEL 2110 (BUG SPRAY)

IS-50-474

### GENERAL EXPLODED VIEW

THE GENERAL DESIGN AND PARTS SHOWN WILL VARY TO INDIVIDUAL UNITS COVERED ON THIS INSTRUCTION SHEET

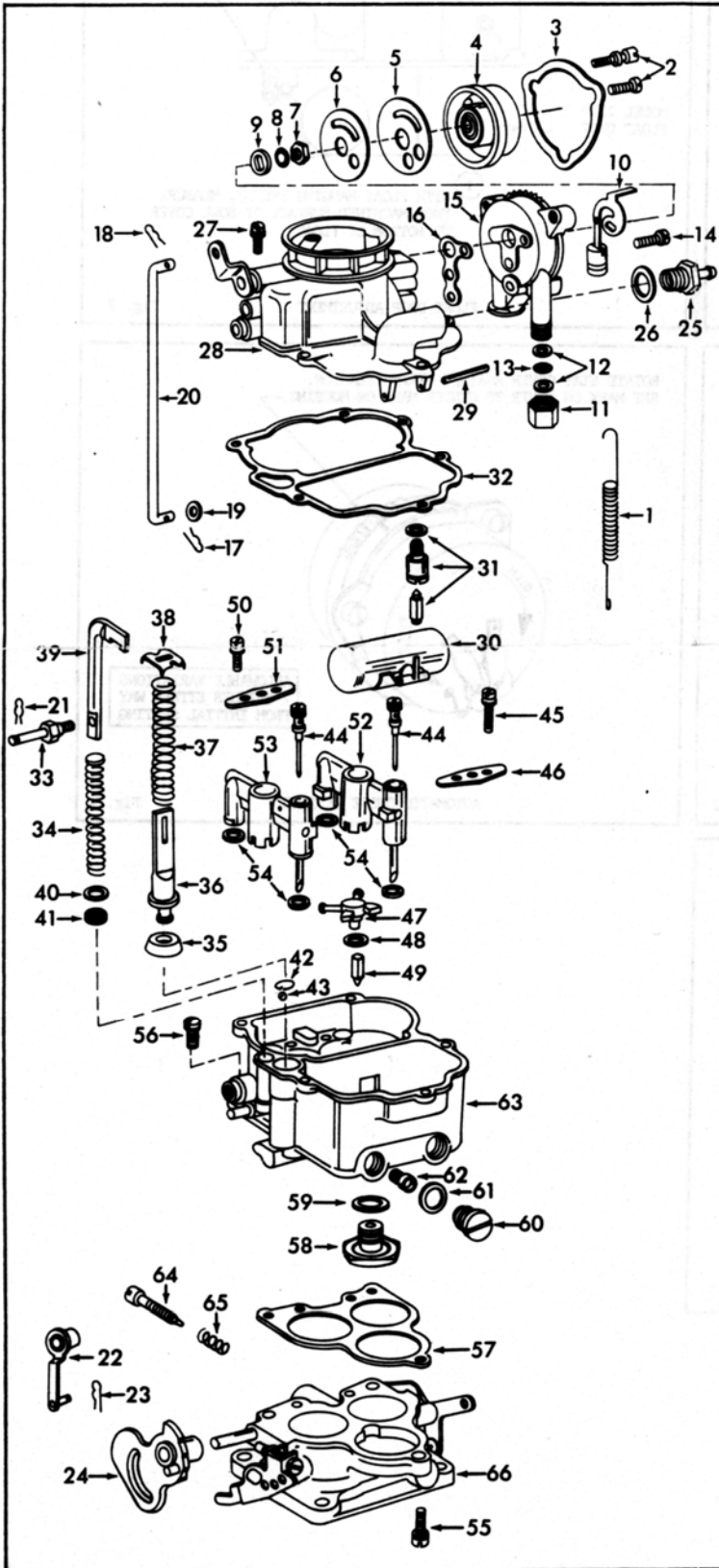

### DISASSEMBLY

USE EXPLODED VIEW AS A GUIDE. THE NUMERICAL SEQUENCE MAY BE FOLLOWED TO DISASSEMBLE UNIT FAR ENOUGH TO PERMIT CLEANING AND INSPECTION.

### NOMENCLATURE

REF. NO.	REF. NO.
1. SPRING-THROTTLE RETURN	35. CUP-PUMP PISTON
2. SCREW(3)-STAT COVER RETAINER	36. PISTON-PUMP
3. RETAINER-ELEC. STAT COVER	37. SPRING-PUMP
4. ELEC. STAT COVER	38. RETAINER-PUMP SPRING
5. GASKET-STAT COVER	39. ROD-PUMP OPERATING
6. PLATE-CHOKE BAFFLE	40. WASHER-PUMP ROD LUBRICATOR
7. NUT-CHOKE SHAFT	41. LUBRICATOR-PUMP ROD
8. LOCKWASHER-CHOKE SHAFT NUT	42. RETAINER-CHECK BALL
9. SPACER-CHOKE LEVER	43. BALL-PUMP INTAKE CHECK
10. LINK & PISTON ASSY.-CHOKE	44. JET(2)-IDLE
11. FITTING-SCREW	45. SCREW & LOCKWASHER(2)-NOZZLE BAR & PUMP JET RETAINER
12. WASHER(2)-SCREEN	46. BAR-CLAMP
13. SCREEN-CHOKE FILTER	47. NOZZLE-PUMP DISCHARGE
14. SCREW & LOCKWASHER(2)-CHOKE HOUSING	48. GASKET-PUMP DISC. NOZZLE
15. HOUSING ASSY.-CHOKE	49. NEEDLE VALVE-PUMP DISC.
16. GASKET-CHOKE HOUSING	50. SCREW & LOCKWASHER(2)-NOZZLE BAR
17. RETAINER-CHOKE ROD	51. BAR-CLAMP
18. RETAINER-CHOKE ROD	52. NOZZLE ASSY. RH
19. WASHER-CHOKE ROD	53. NOZZLE ASSY. LH
20. ROD-CHOKE	54. GASKET(4)-NOZZLE ASSY.
21. RETAINER-PUMP LINK	55. SCREW & LOCKWASHER-THROTTLE BODY
22. LINK-PUMP	56. SCREW & LOCKWASHER(2)-THROTTLE BODY
23. RETAINER-FAST IDLE CAM	57. GASKET-THROTTLE BODY
24. CAM-FAST IDLE	58. PLUG-BOWL
25. FITTING-FUEL INLET	59. GASKET-BOWL PLUG
26. GASKET-FUEL INLET FITTING	60. PLUG(2)-MAIN JET
27. SCREW & LOCKWASHER(5)-BOWL COVER	61. GASKET(2)-MAIN JET PLUG
28. BOWL COVER ASSY.	62. JET(2)-MAIN
29. PIN-FLOAT LEVER	63. BOWL ASSY.
30. FLOAT & LEVER ASSY.	64. NEEDLE(2)-IDLE ADJ.
31. NEEDLE SEAT & GASKET ASSY.	65. SPRING(2)-IDLE ADJ. NEEDLE
32. GASKET-BOWL COVER	66. THROTTLE BODY ASSY.
33. STUD-PUMP LINK	
34. SPRING-PUMP RETURN	

### CLEANING

CLEANING MUST BE DONE WITH CARBURETOR DISASSEMBLED. SOAK PARTS LONG ENOUGH TO SOFTEN AND REMOVE ALL FOREIGN MATERIAL. USE A CARBURETOR CLEANING SOLVENT. MAKE CERTAIN THE THROTTLE BODY IS FREE OF ALL HARD CARBON DEPOSITS. WASH OFF IN SUITABLE SOLVENT. BLOW OUT ALL PASSAGES IN CASTINGS WITH COMPRESSED AIR AND CHECK CAREFULLY TO INSURE THOROUGH CLEANING OF OBSCURE AREAS.

CAUTION: DO NOT SOAK PARTS CONTAINING RUBBER, LEATHER OR ELECTRIC CHOKE STAT COVER (4) IN CLEANING SOLVENTS.

### REASSEMBLY

REASSEMBLE IN REVERSE ORDER OF DISASSEMBLY. NOTE SPECIAL INSTRUCTIONS AND FOLLOW NUMERICAL OUTLINE IN MAKING ADJUSTMENTS.

### SPECIAL INSTRUCTIONS

WHEN INSTALLING IDLE MIXTURE ADJUSTING NEEDLES (64), LIGHTLY BOTTOM THEN BACK OUT 1 1/2 TURNS.

CHOKE STAT COVER (4)-WHEN INSTALLING BE SURE COIL SPRING LOOP IS HOOKED ONTO LEVER ARM.

# ADJUSTMENTS

