

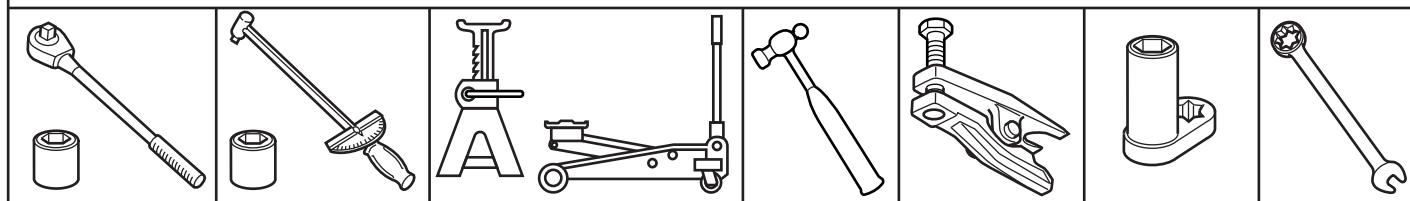

# 2" LIFT KIT RAM

Kit de levage 2 "  
Kit de elevación de 2 "

www.mopar.com

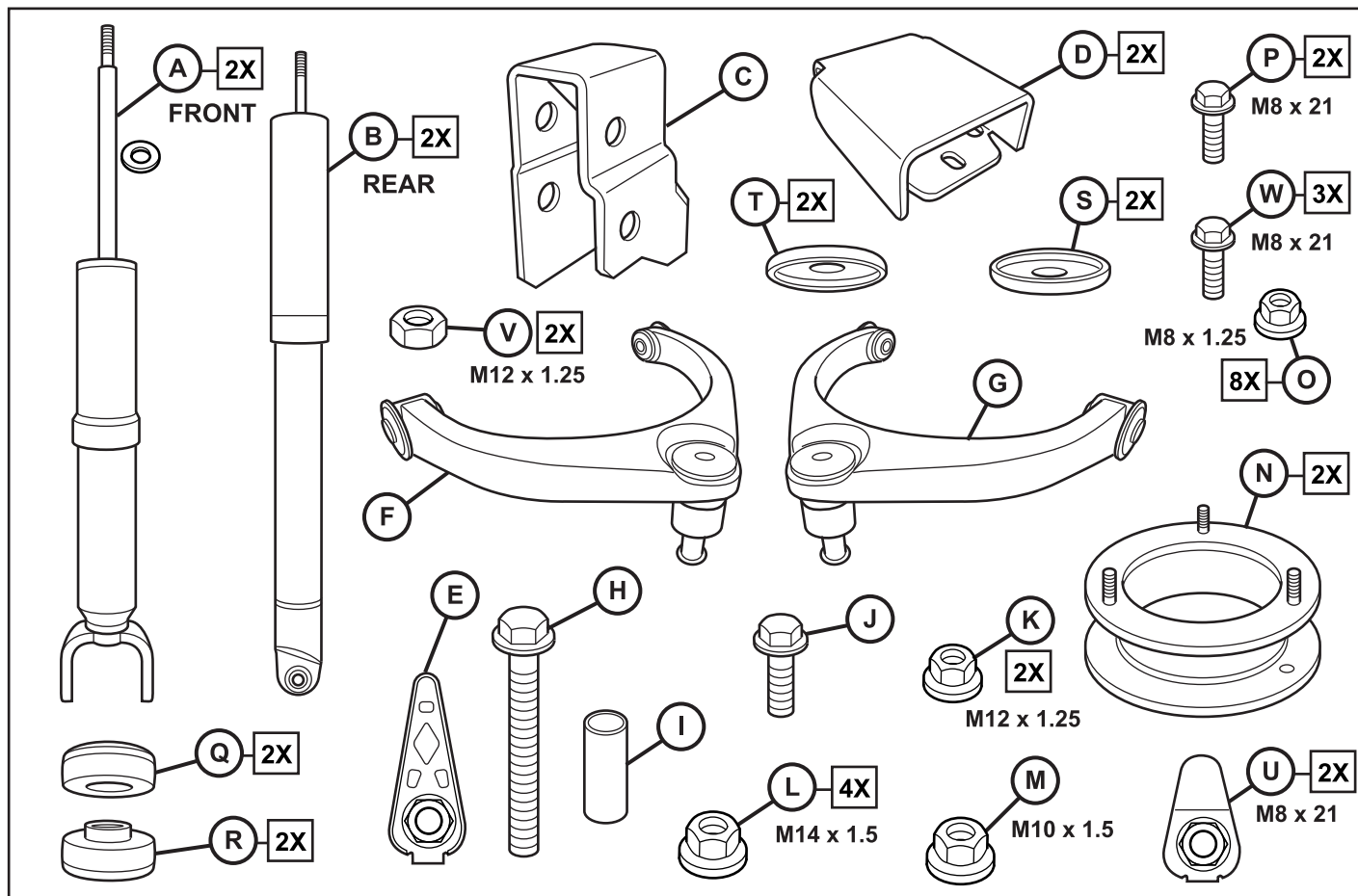

## IMPORTANT:

Prior to beginning, inspect the vehicles steering, driveline, and brake systems, paying close attention to the suspension link arms and bushings, stabilizer bars and bushings, tie rod ends, pitman arm, ball joints and wheel bearings.























Also check the steering sector-to-frame and all suspension-to-frame attaching points for stress cracks.

The overall vehicle must be in excellent working condition. Repair or replace all worn parts.

Read instructions several times before starting.

Be sure you have all needed parts and know where they install. Read each step completely as you go.

**RETAIN ALL FASTENERS FOR LATER REINSTALLATION.**

PART DESCRIPTION		PART NUMBER	QTY
(P)	 REAR BUMPER PAD BOLT M8 x 1.25 x 21	05143356AC	2
(O)	 SPRING SPACER / BUMPER PAD NUT M8 x 1.25	06101695	8
(M)	 REAR TRACK BAR NUT M10 x 1.5	06101696	1
(H)	 REAR TRACK BAR SPACER BOLT M14 x 1.5 x 90	06104265AA	1
(V)	 REAR SHOCK UPPER NUT M12 x 1.25	06503029	2
(K)	 FRONT SHOCK NUT M12 x 1.25	06506276AA	2
(L)	 FRONT UCA BALL JOINT / TIE ROD NUT M14 x 1.5	0650557AA	4
(W)	 REAR TRACK BAR / BUMPER PAD BOLT M10 x 1.5 x 25	06508224AA	3
(E)	 REAR TRACK BAR SPACER FLAG NUT M14 x 1.5	06511267AA	1
(T)	 REAR SHOCK UPPER WASHER	52038257	2
(S)	 REAR SHOCK LOWER WASHER	52038258	2
(Q)	 REAR SHOCK UPPER BUSHING	68157180AA	2
(R)	 REAR SHOCK LOWER BUSHING	68157184AA	2
(A)	 FRONT SHOCK	68660472AA	2
(B)	 REAR SHOCK	68660473AA	2
(F)	 FRONT UPPER CONTROL ARM RH	68323530AA	1
(G)	 FRONT UPPER CONTROL ARM LH	68323531AA	1
(N)	 REAR SPRING SPACER	68323532AA	2
(C)	 REAR TRACK BAR BRACKET	6839394IAB	1
(D)	 REAR BUMPER PAD SPACER	68393948AA	2
(I)	 REAR TRACK BAR SPACER	68426828AA	1
(U)	 REAR TRACK BUMPER PAD FLAG NUT M10 x 1.5	06507078AA	2

### FRONT DISASSEMBLY

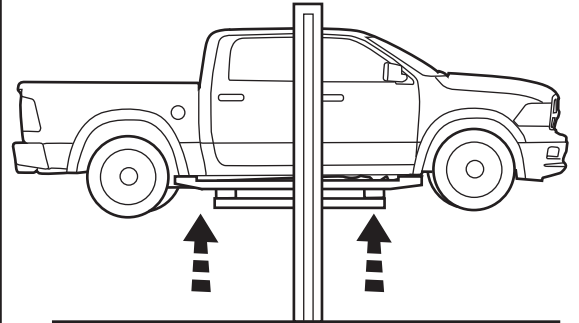
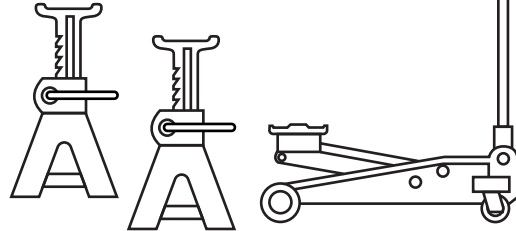
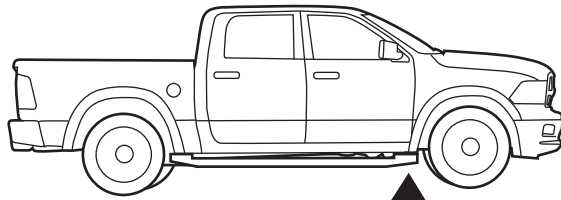

2

### REMOVE FRONT TIRE

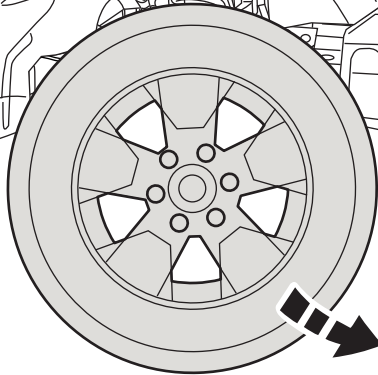
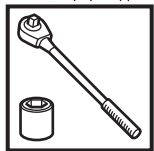

3

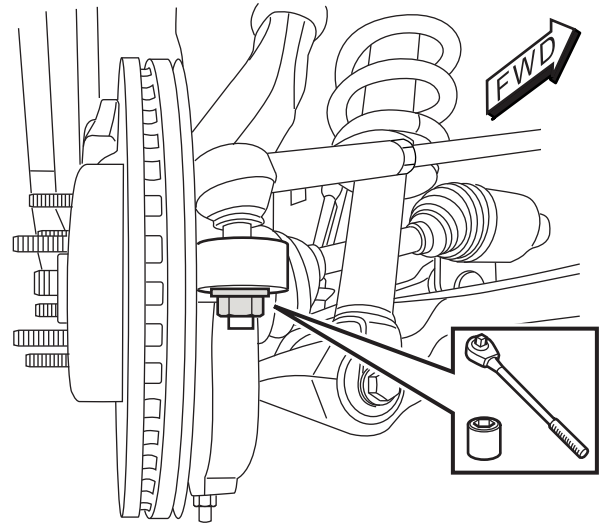

4

LOOSEN TIE ROD, DO NOT REMOVE

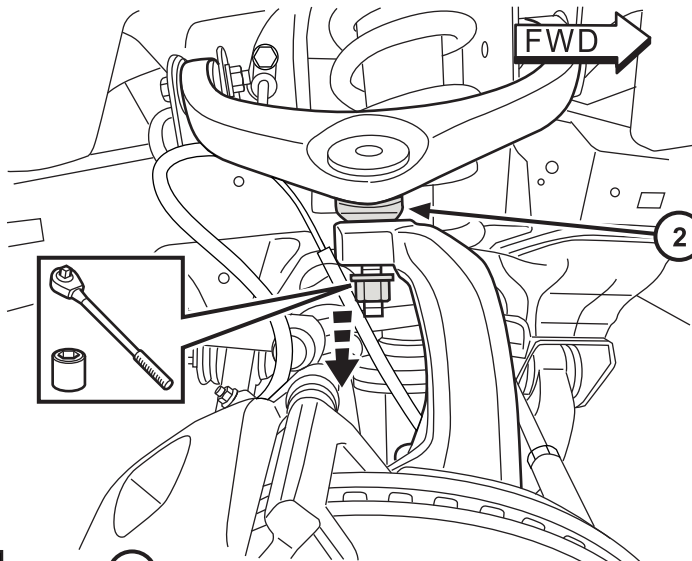

2 LOOSEN UPPER BALL JOINT

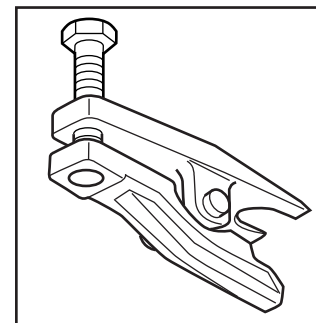

SEPARATOR TOOL RECOMMENDED

5

1 LOOSEN UPPER ARM NUT

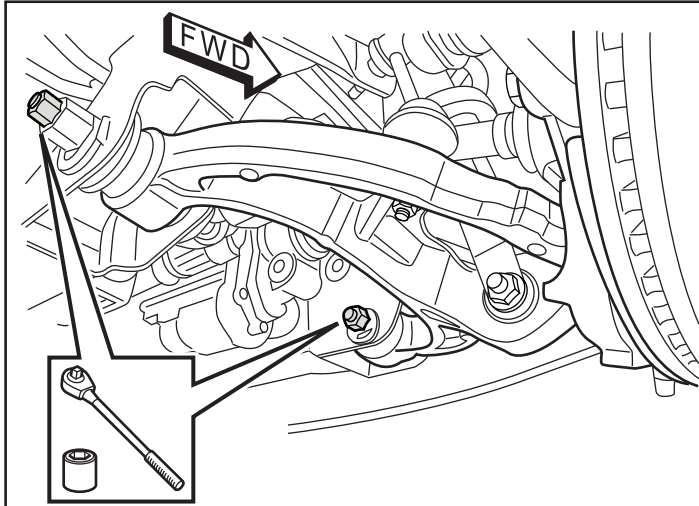

**6** LOOSEN (2) LOWER ARM BOLTS

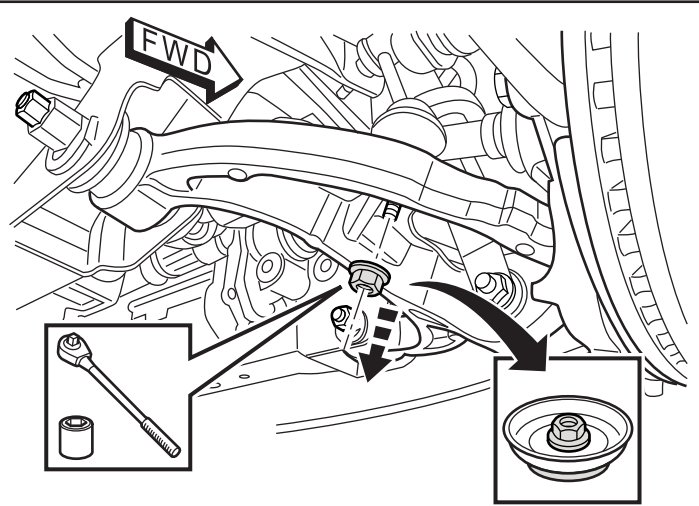

**7** REMOVE LOWER STABILIZER LINK NUT AND RETAIN FOR REINSTALLATION

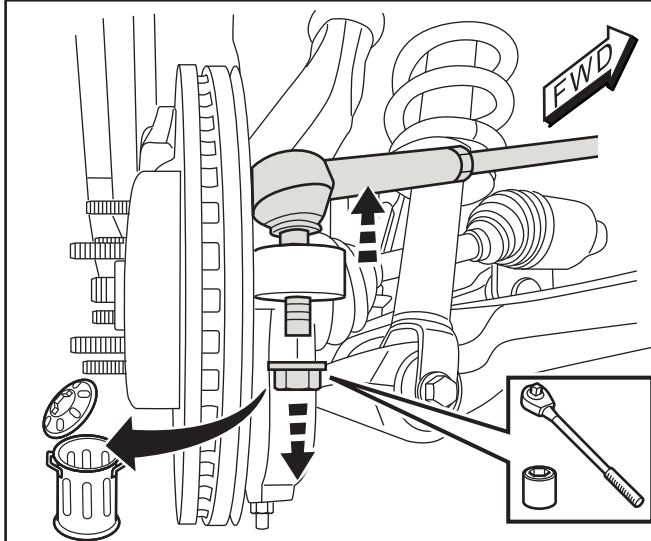

**8** FULLY REMOVE TIE ROD

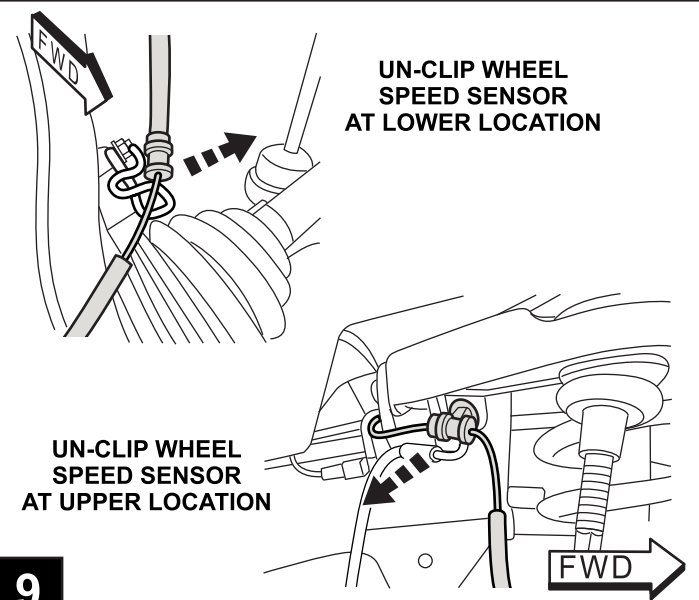

UN-CLIP WHEEL SPEED SENSOR AT LOWER LOCATION  
UN-CLIP WHEEL SPEED SENSOR AT UPPER LOCATION

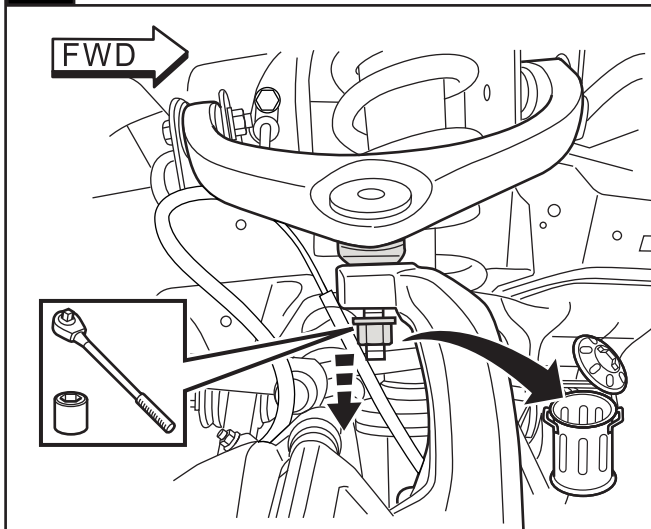

**10** REMOVE UPPER ARM NUT AND DISCARD

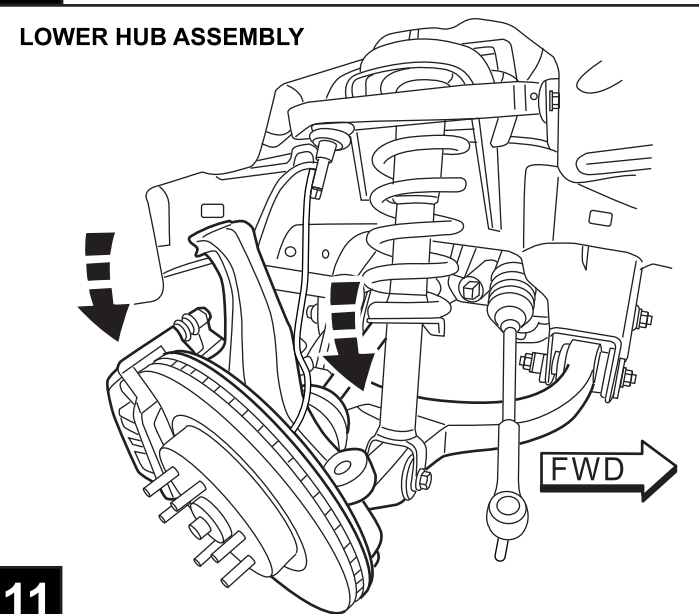

**11** LOWER HUB ASSEMBLY

REMOVE UPPER CONTROL ARM BOLTS

FWD

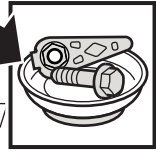
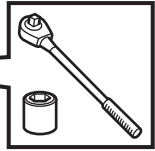

12

FWD

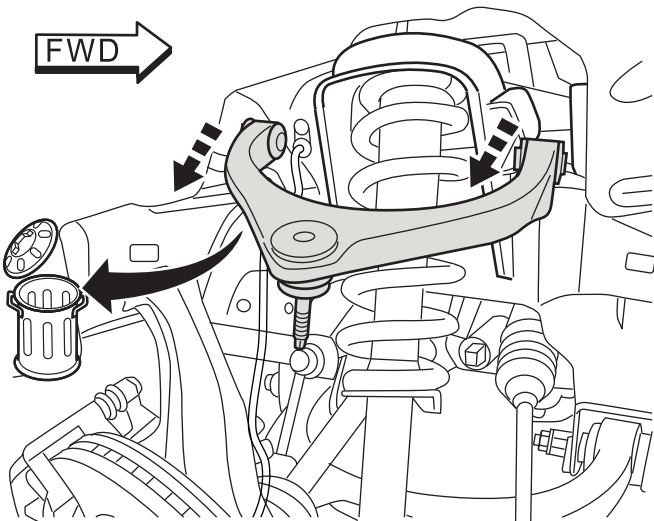

13

REMOVE UPPER CONTROL ARM

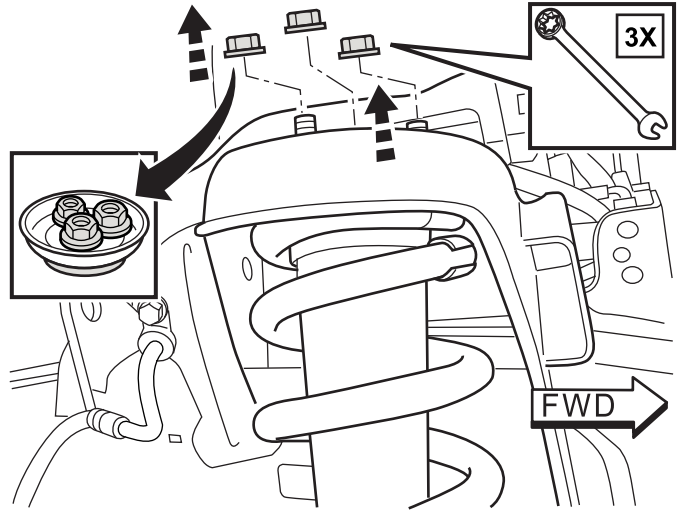

14

REMOVE (3) NUTS AT TOP OF STRUT AND RETAIN FOR REINSTALLATION

FWD

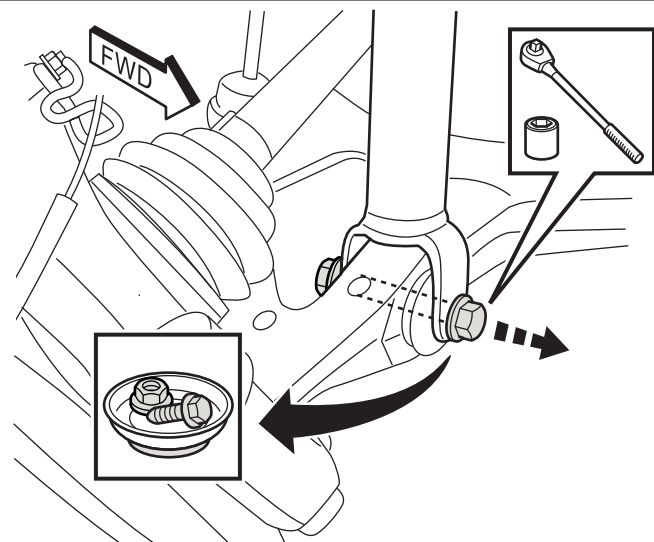

15

REMOVE FASTENERS AT BOTTOM OF STRUT AND RETAIN FOR REINSTALLATION

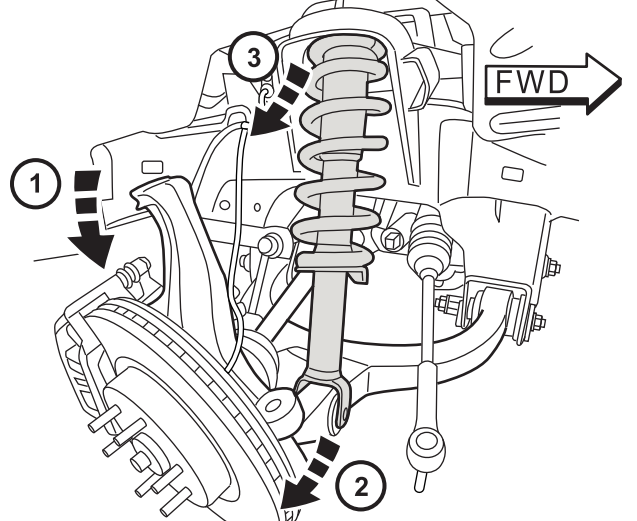

16

REMOVE SHOCK ASSEMBLY FROM VEHICLE

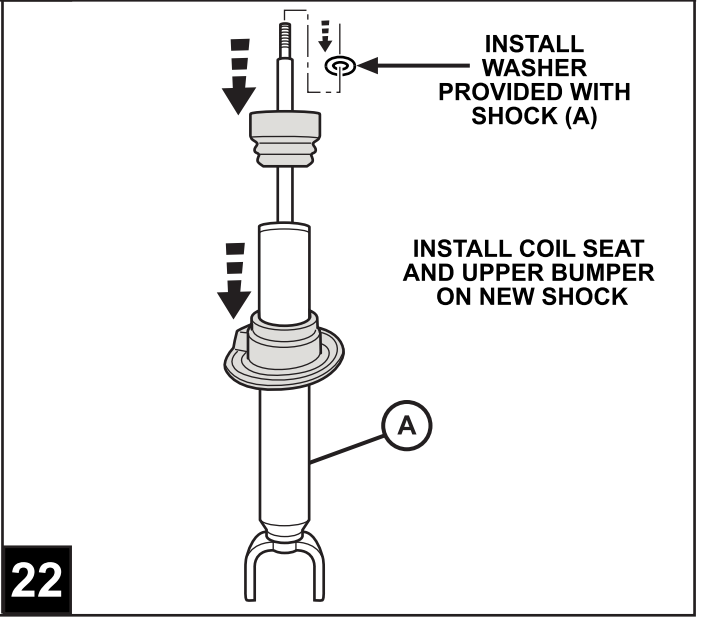
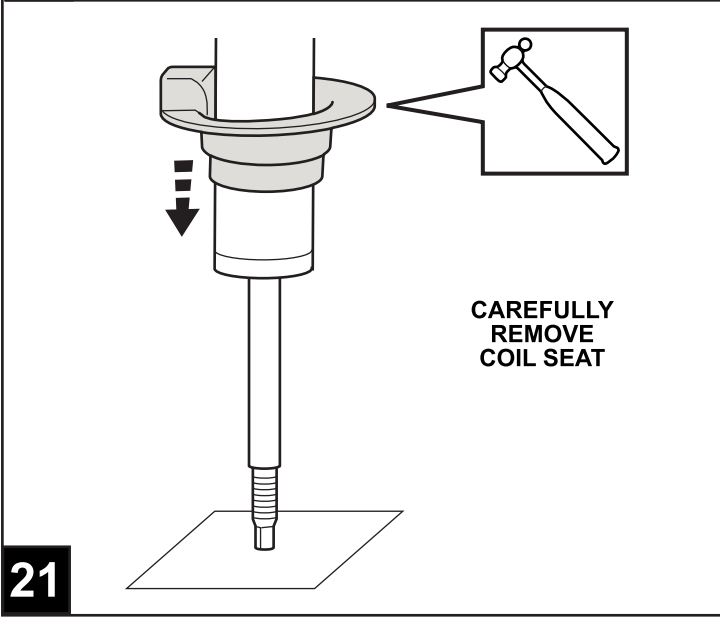
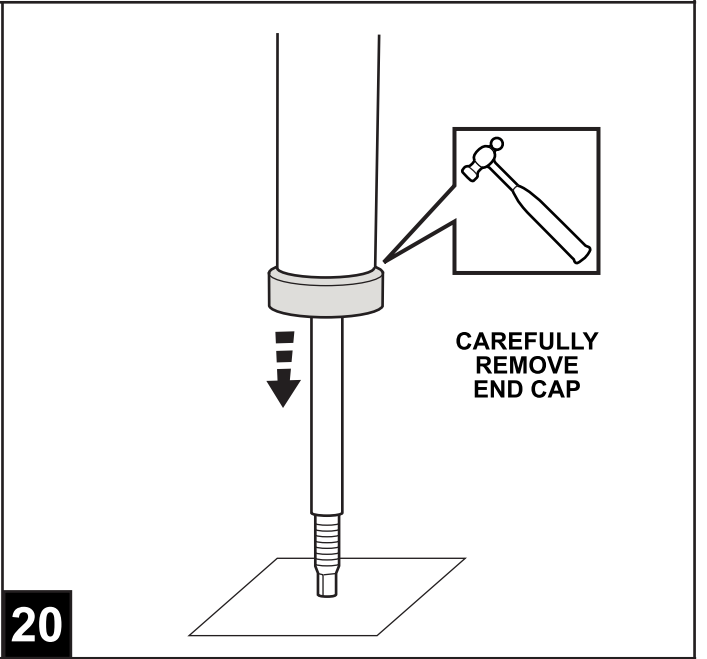
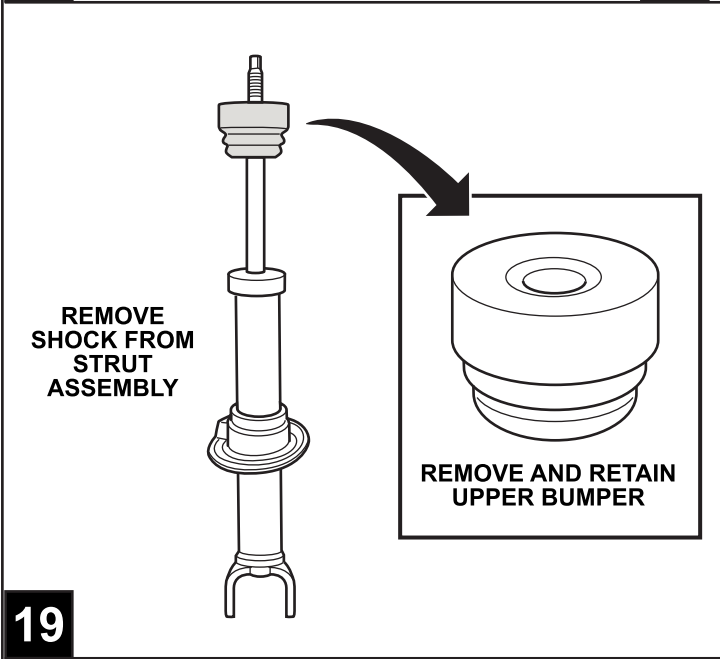
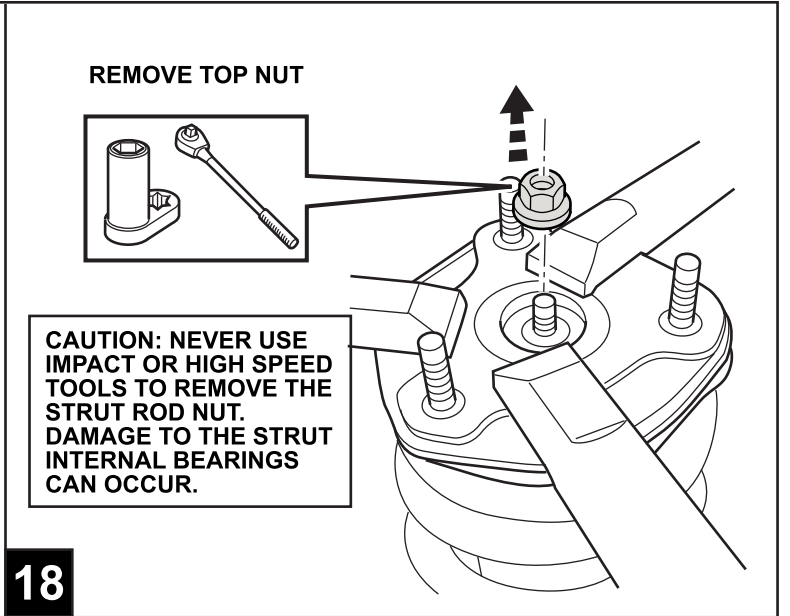
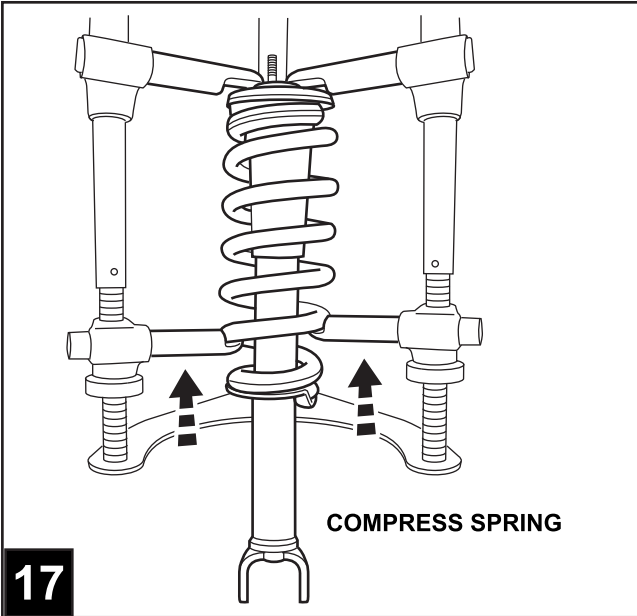

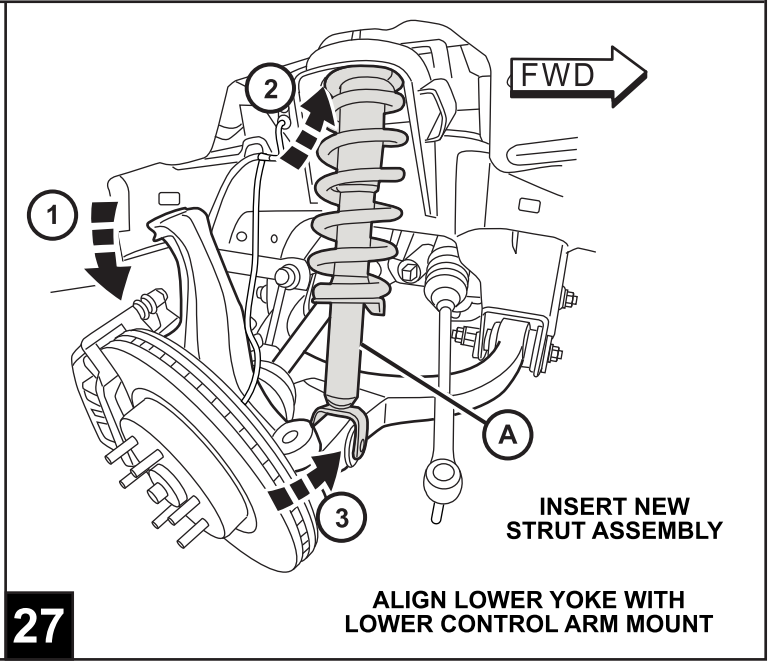
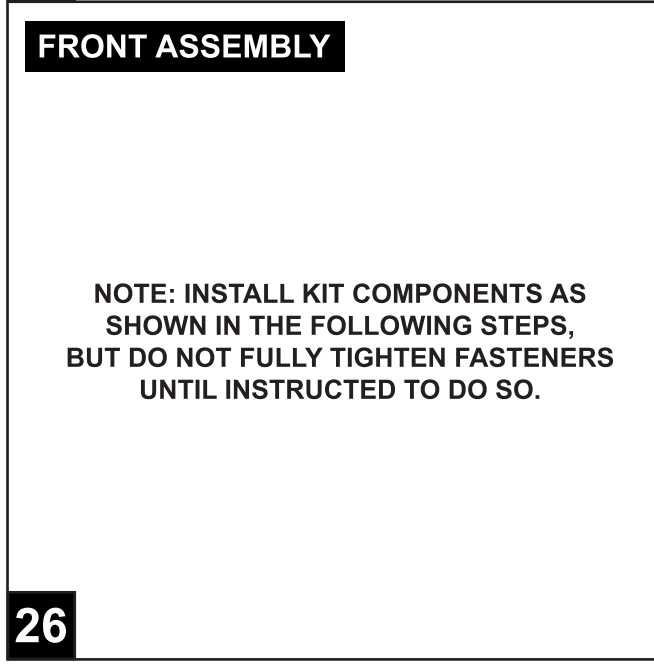
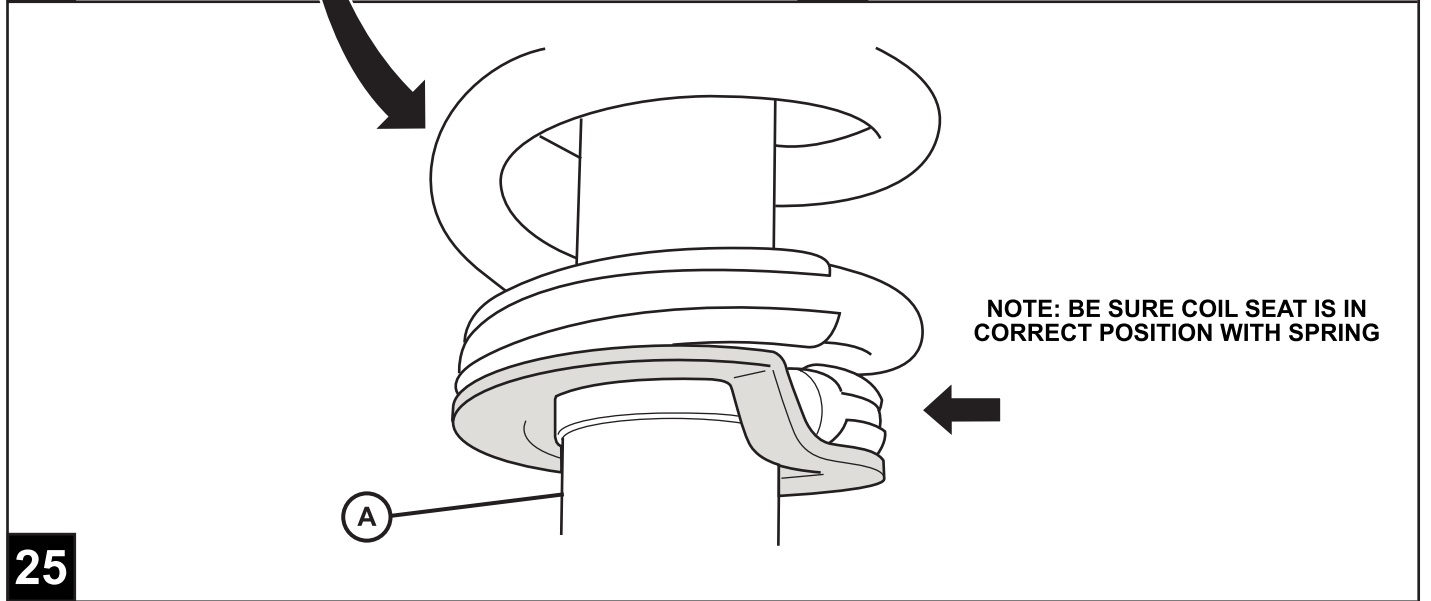
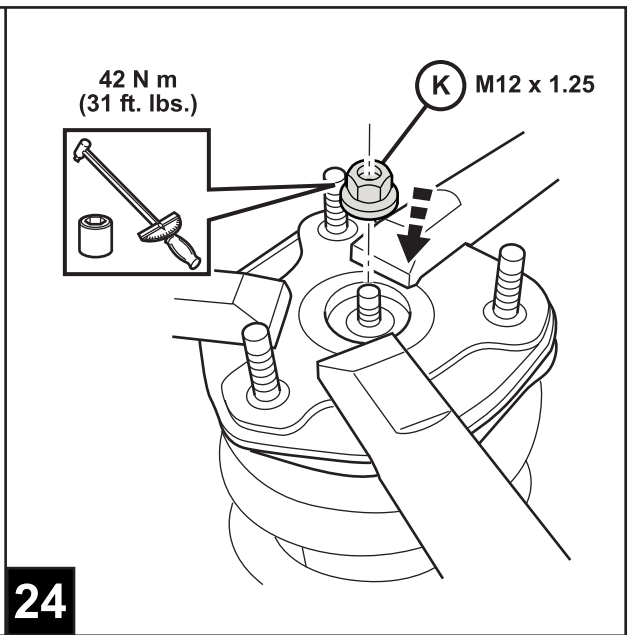
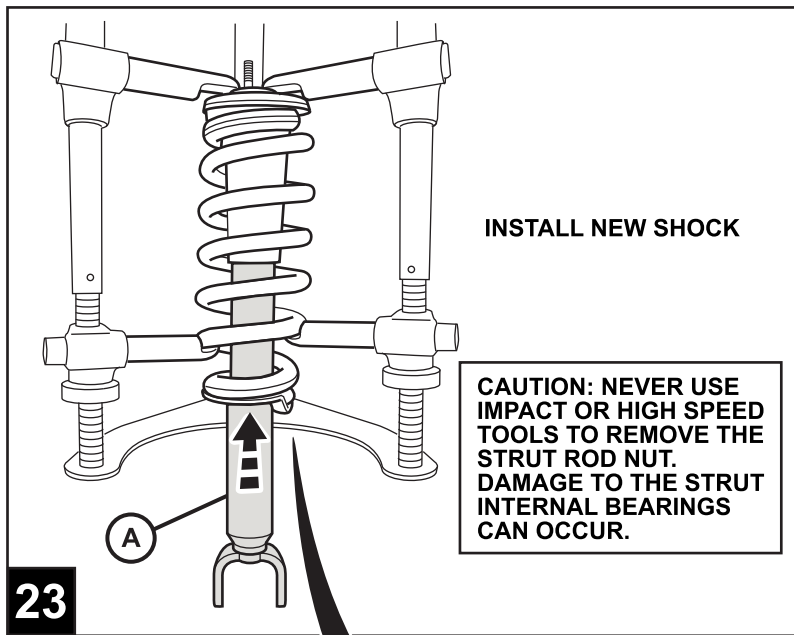

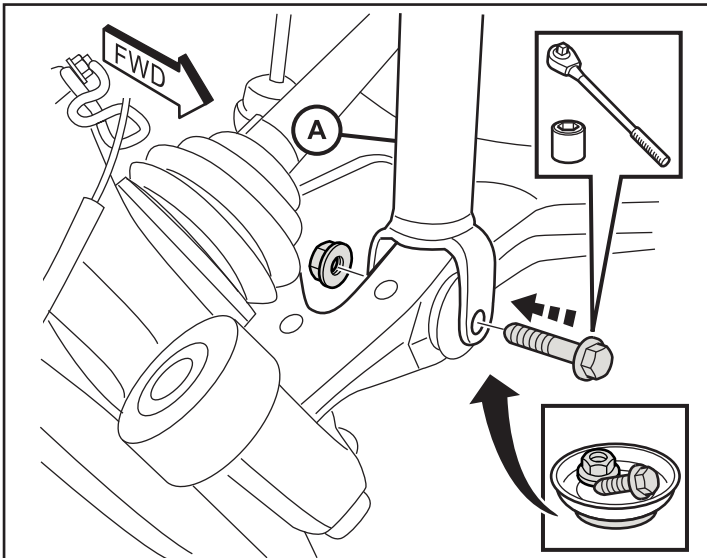

28

REINSTALL FASTENERS AT BOTTOM OF STRUT

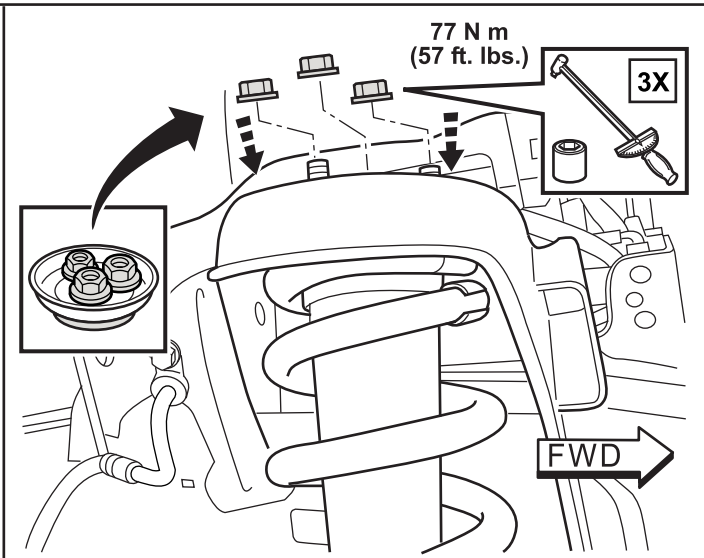

29

REINSTALL (3) NUTS AT TOP OF STRUT

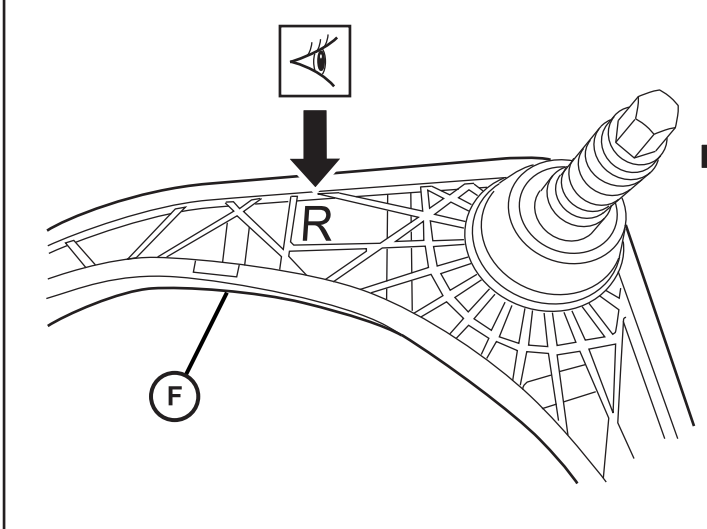

30

NOTE: CHECK ARM TO VERIFY RIGHT OR LEFT

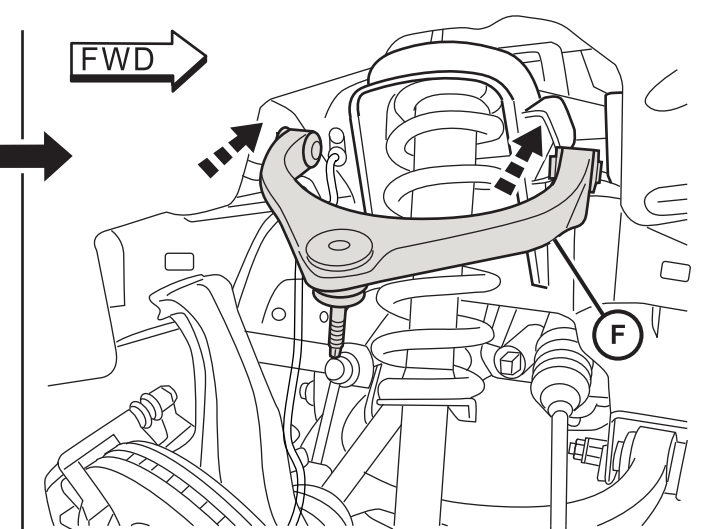

INSTALL NEW UPPER CONTROL ARM (F)

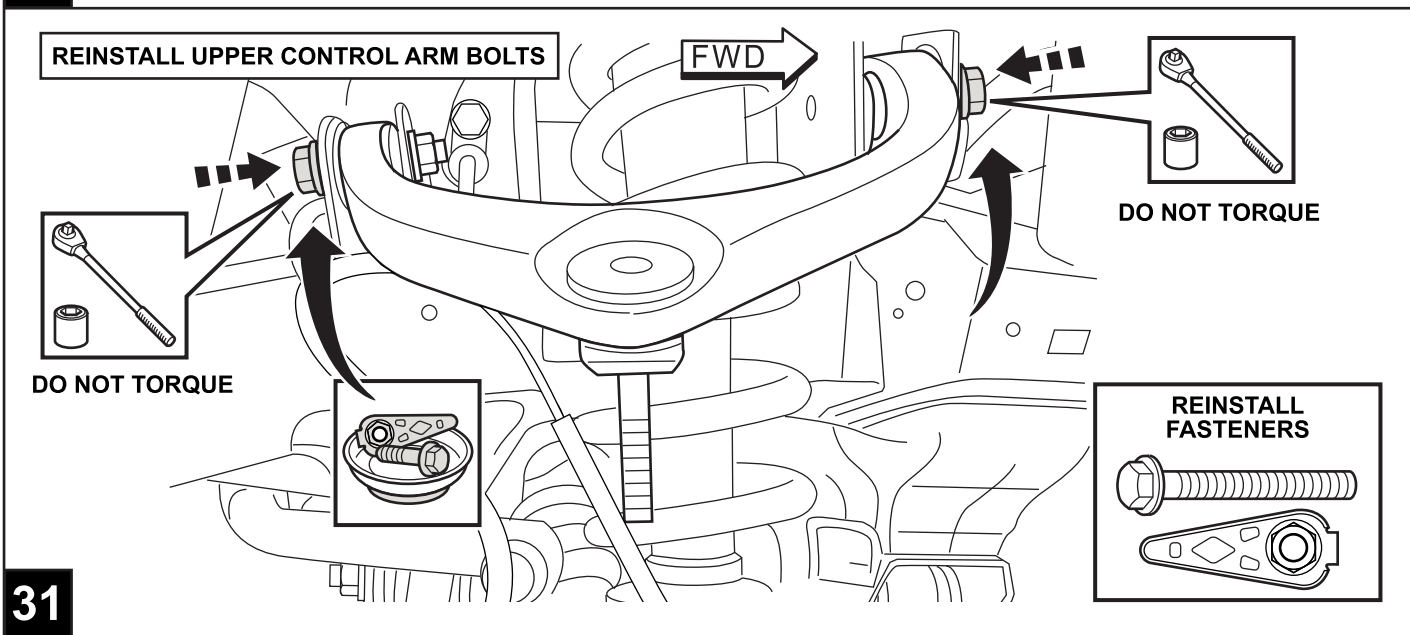

31

REVERSE STEPS 3 THROUGH 10 TO REASSEMBLE VEHICLE COMPONENTS

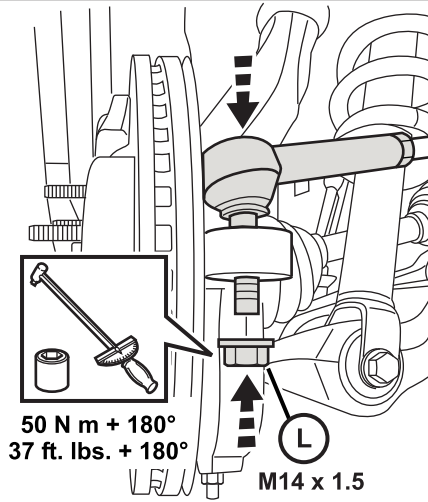

**33** NOTE: USE NEW NUT (L) FOR STEP 8 REASSEMBLY

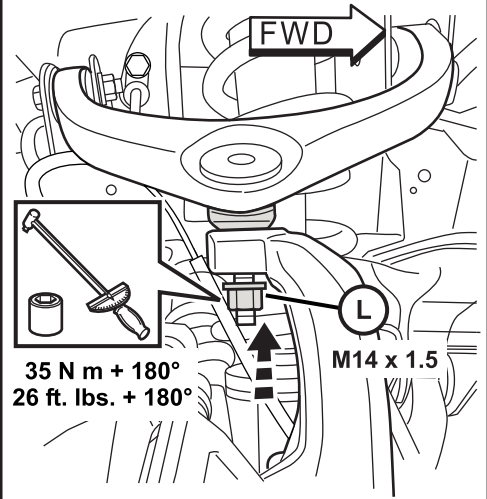

**34** NOTE: USE NEW NUT (L) FOR STEP 5 REASSEMBLY

REPEAT STEPS 3 THROUGH 32 ON OPPOSITE SIDE OF VEHICLE

NOTE: EXTRA HARNESS CLIPS MUST BE DISCONNECTED ON DRIVER SIDE

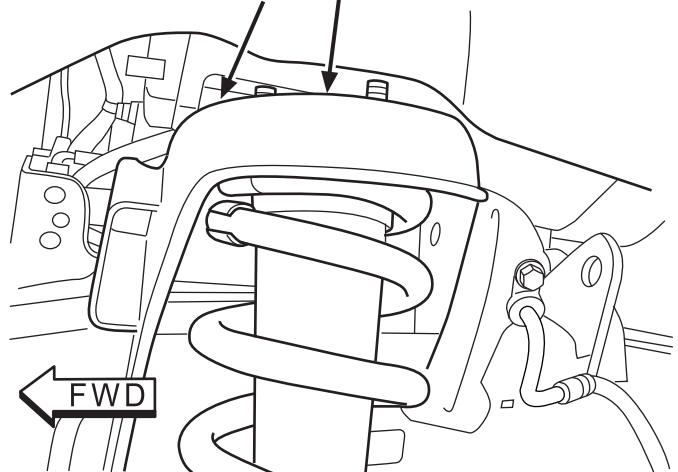

**35**

**36**

**REAR DISASSEMBLY**

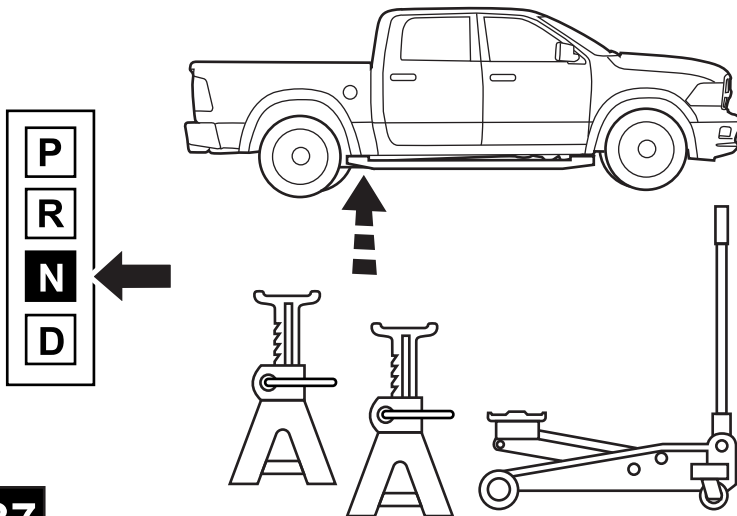

**37**

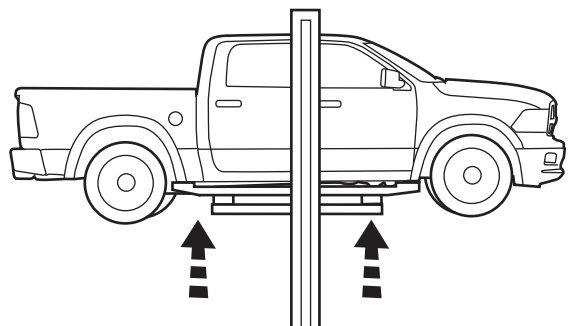

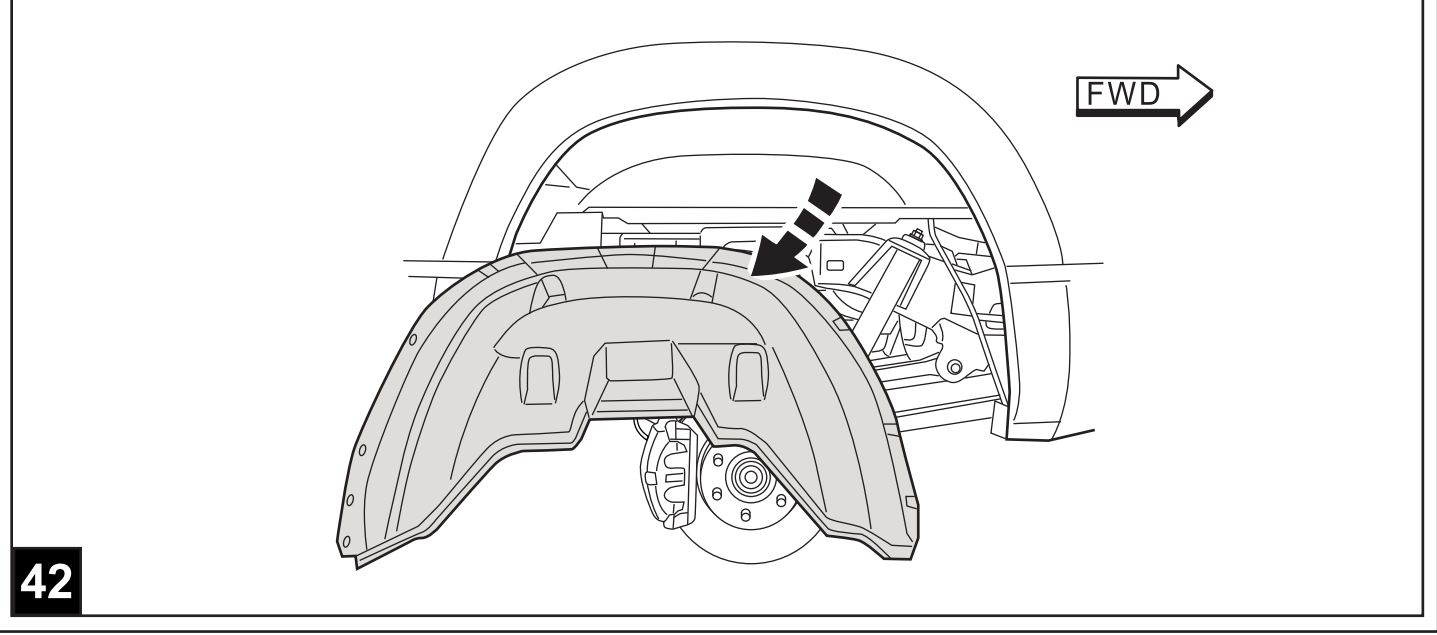
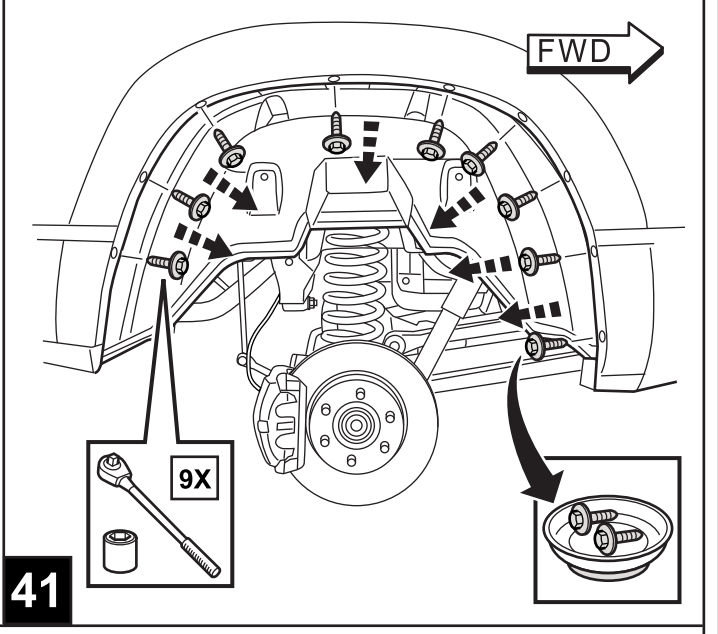
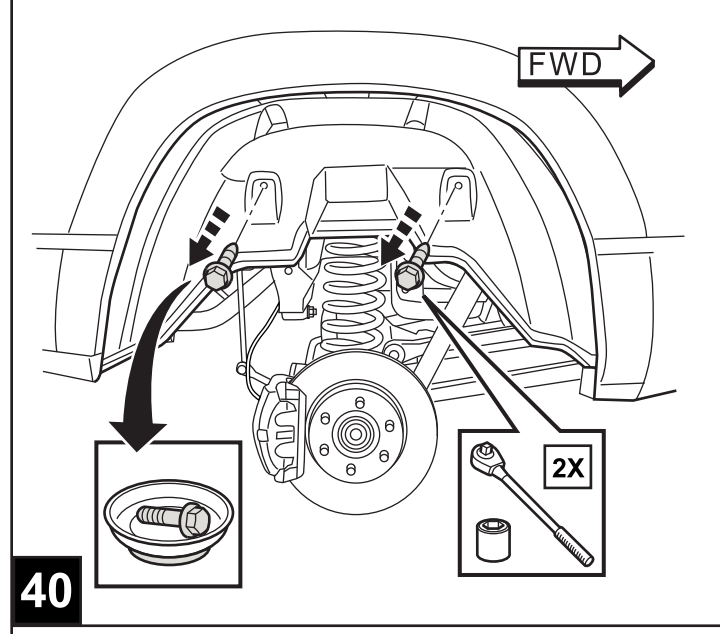
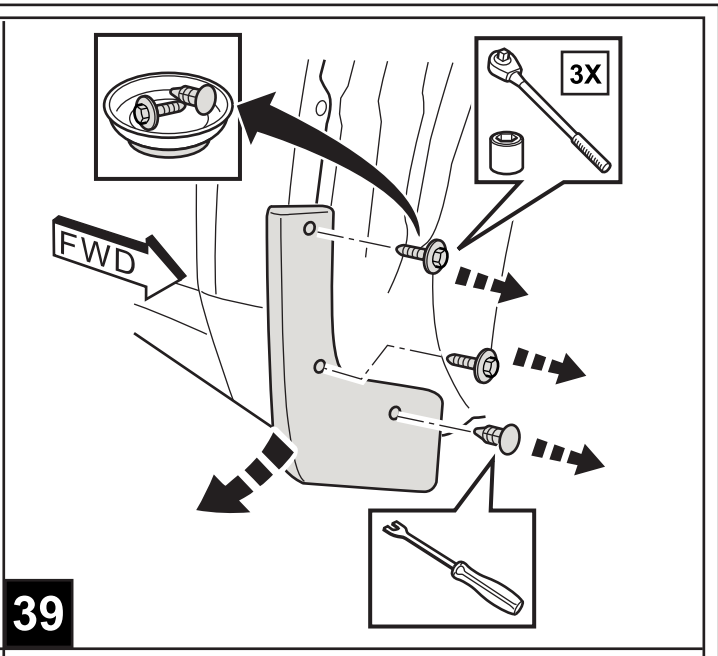
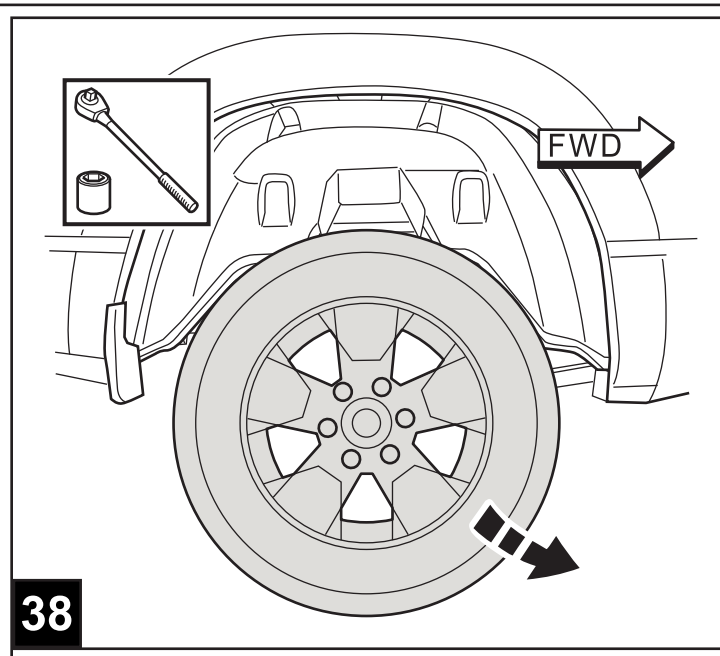

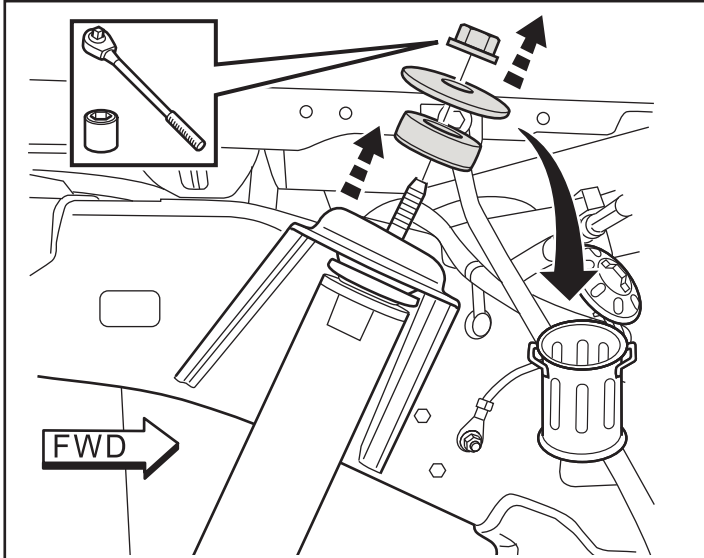

**43** REMOVE UPPER SHOCK FASTENER, WASHERS AND AND BUSHINGS AND DISCARD

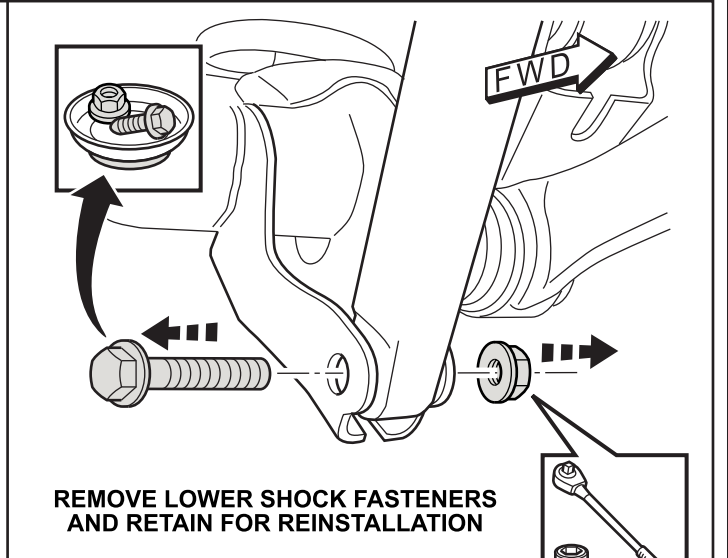

**44** REMOVE LOWER SHOCK FASTENERS AND RETAIN FOR REINSTALLATION

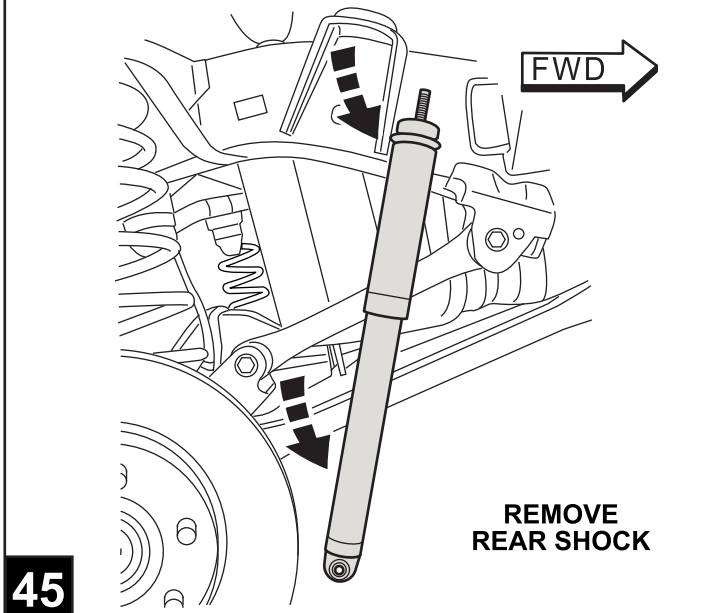

**45** REMOVE REAR SHOCK

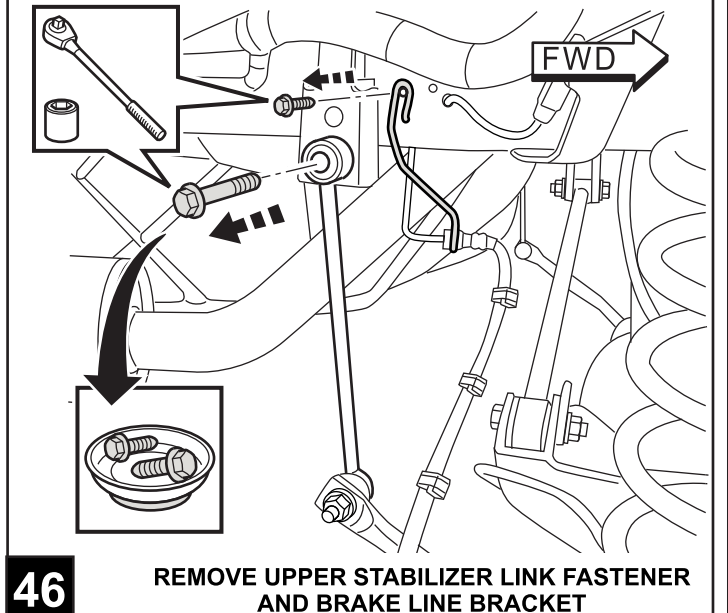

**46** REMOVE UPPER STABILIZER LINK FASTENER AND BRAKE LINE BRACKET

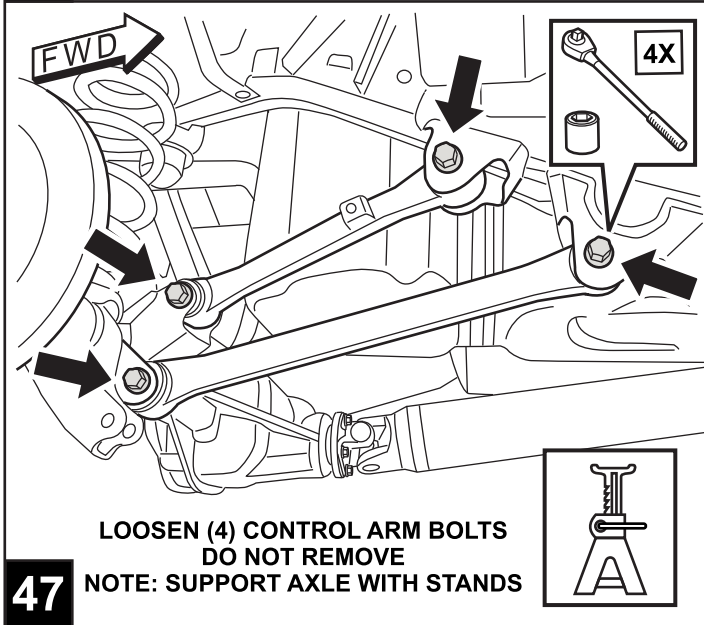

**47** LOOSEN (4) CONTROL ARM BOLTS DO NOT REMOVE NOTE: SUPPORT AXLE WITH STANDS

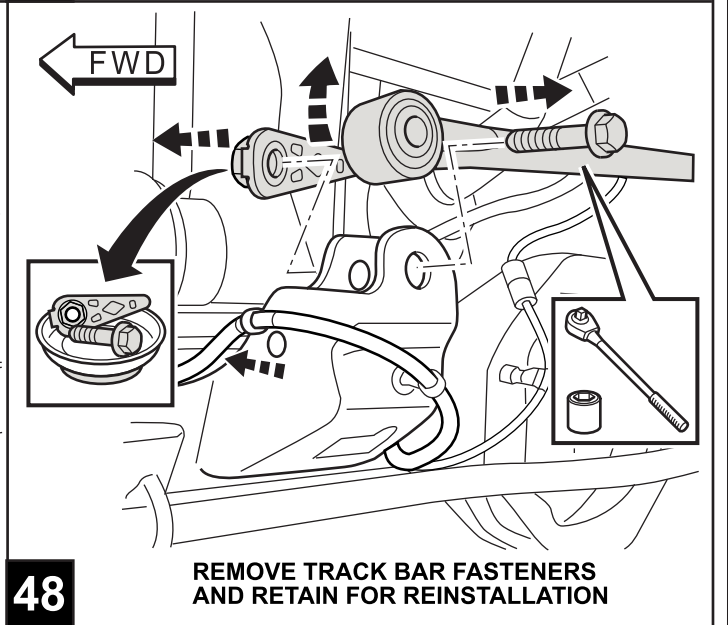

**48** REMOVE TRACK BAR FASTENERS AND RETAIN FOR REINSTALLATION

REPEAT STEPS 38 THROUGH 47  
ON OPPOSITE SIDE OF VEHICLE

49

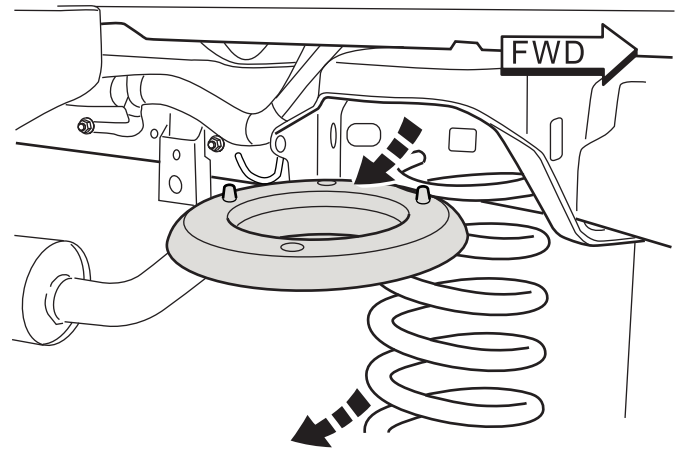

REMOVE AND RETAIN RUBBER COLLAR  
AT TOP OF SPRING. REMOVE SPRING.

50

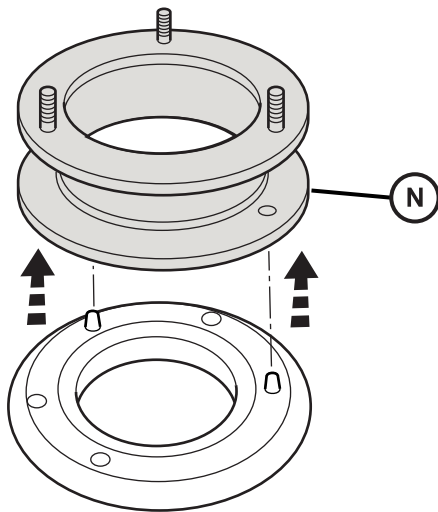

FIT RUBBER COLLAR TO NEW SPACER (N).  
BE SURE TO ALIGN PINS TO HOLES.

51

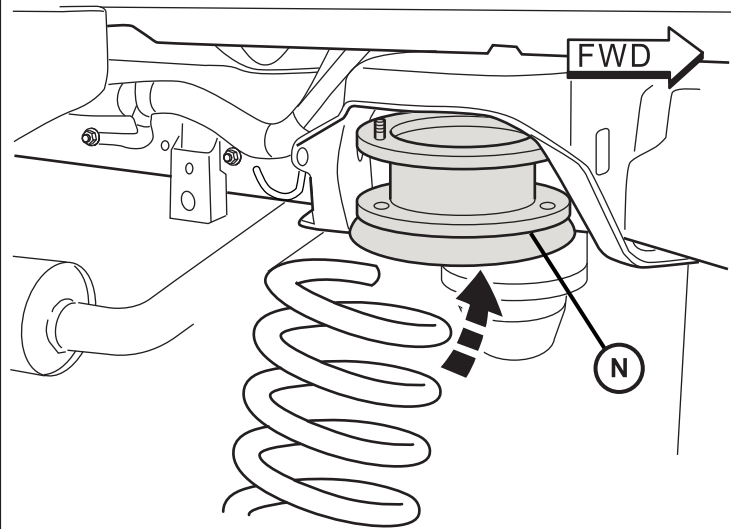

FIT SPACER (H) INTO PLACE.  
REINSTALL SPRING.

52

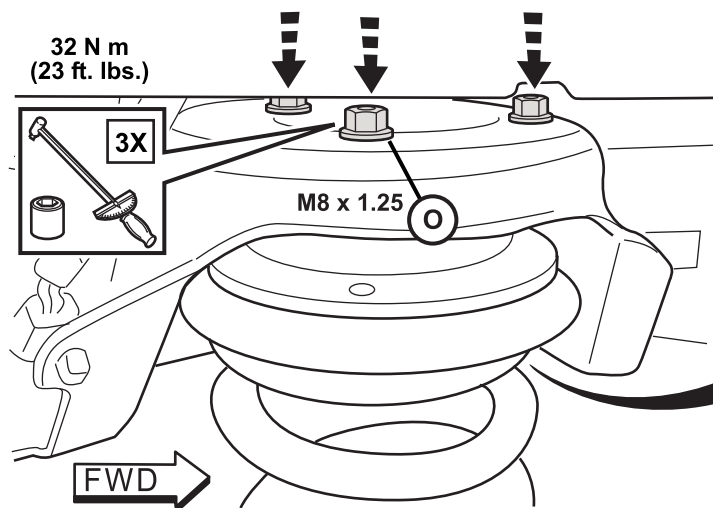

SECURE SPACER (N) WITH NUTS (O)

53

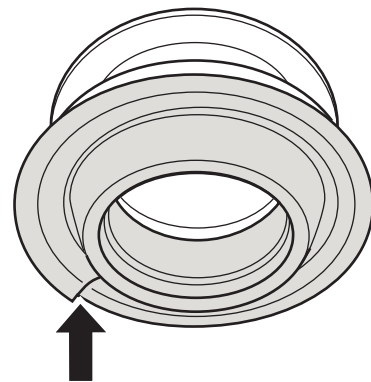

NOTE: BE SURE SPRING IS PROPERLY  
ALIGNED WITH RUBBER COLLAR

REPEAT STEPS 48 THROUGH 51  
ON OPPOSITE SIDE OF VEHICLE

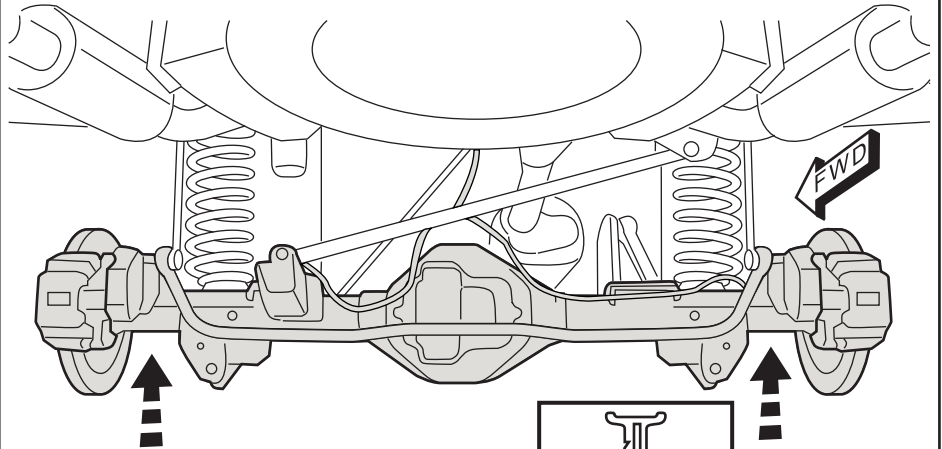

LIFT AND SUPPORT REAR AXLE

54

55

**REAR ASSEMBLY**

NOTE: INSTALL KIT COMPONENTS AS SHOWN IN THE FOLLOWING STEPS,  
BUT DO NOT FULLY TIGHTEN FASTENERS UNTIL INSTRUCTED TO DO SO.

56

**IMPORTANT:**  
DO NOT COMPRESS SHAFT  
PAST THIS SHOULDER

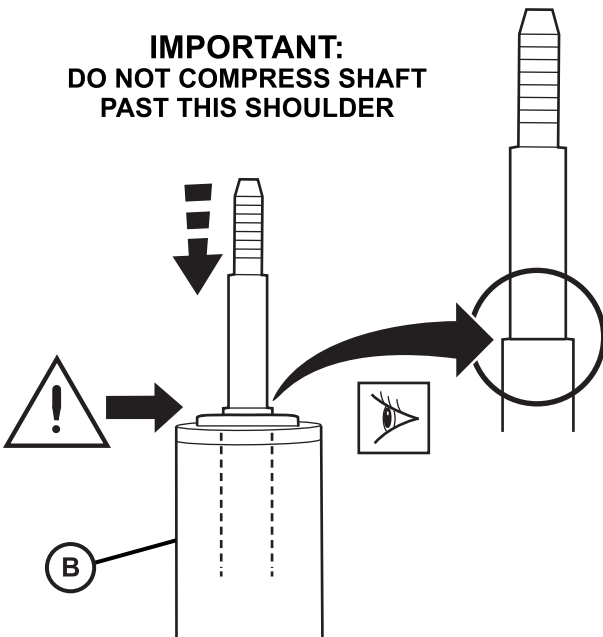

OVER COMPRESSION CAN  
DAMAGE SHOCK SEALS

57

INSTALL NEW  
LOWER BUSHING (R)  
AND WASHER (S)  
ON NEW SHOCK (B)

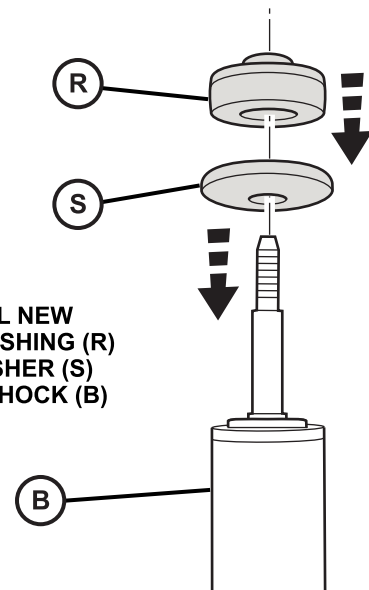

58

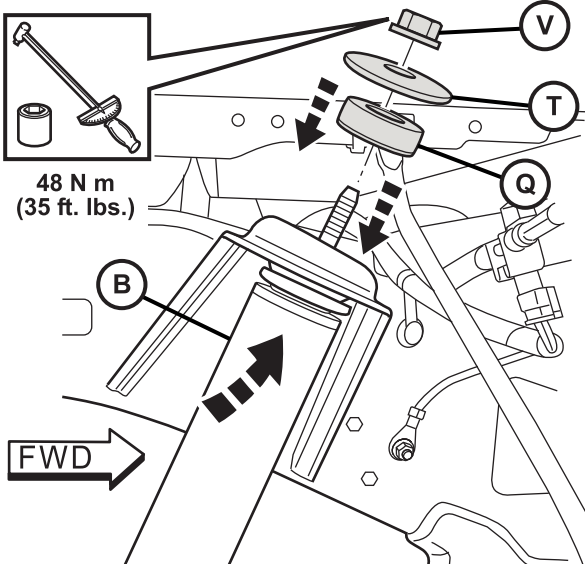

48 N m  
(35 ft. lbs.)

**59** INSTALL NEW SHOCK (B) TOP MOUNT.  
REINSTALL WASHER (T), BUSHING (Q)  
AND NUT (V)

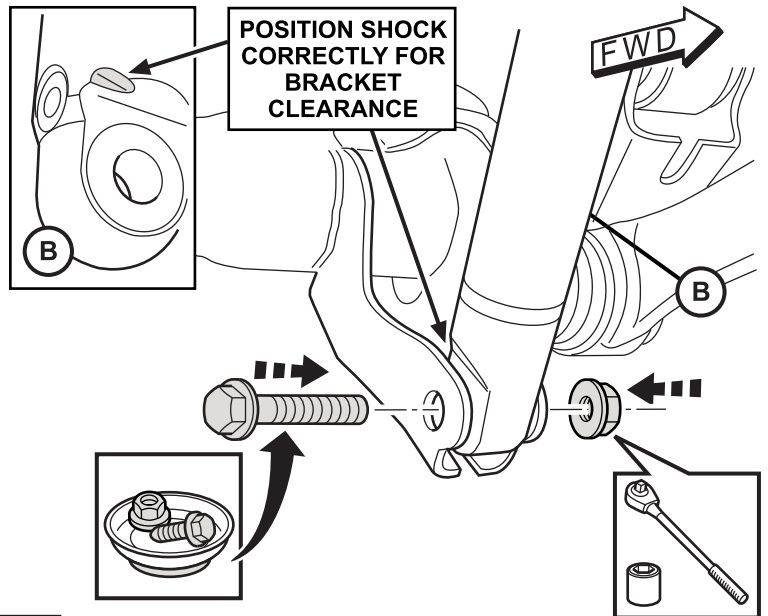

POSITION SHOCK  
CORRECTLY FOR  
BRACKET  
CLEARANCE

**60** INSTALL NEW SHOCK (B) BOTTOM MOUNT

REPEAT STEPS 57 THROUGH 60  
ON OPPOSITE SIDE OF VEHICLE

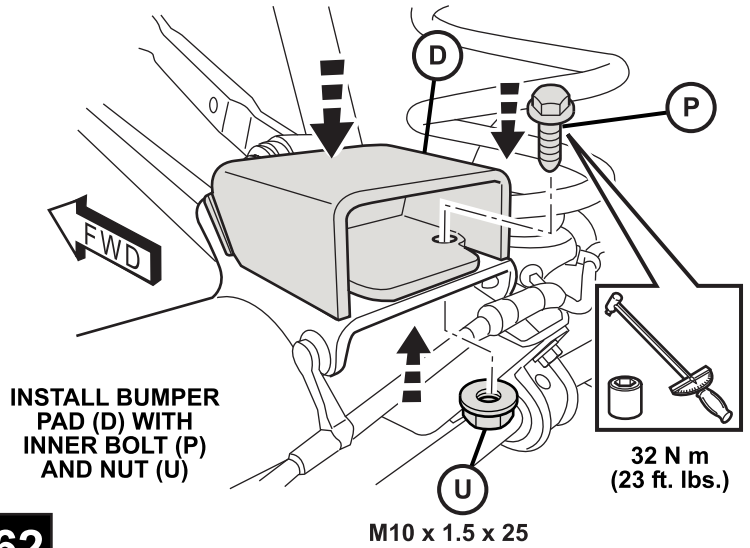

INSTALL BUMPER  
PAD (D) WITH  
INNER BOLT (P)  
AND NUT (U)

32 N m  
(23 ft. lbs.)

M10 x 1.5 x 25

**61**

**62**

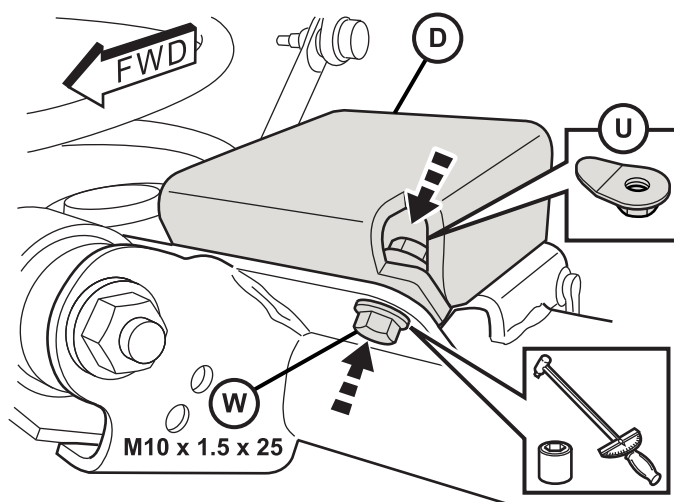

**63** INSTALL FORWARD  
BOLT (W) AND NUT (U)

61 N m  
(45 ft. lbs.)

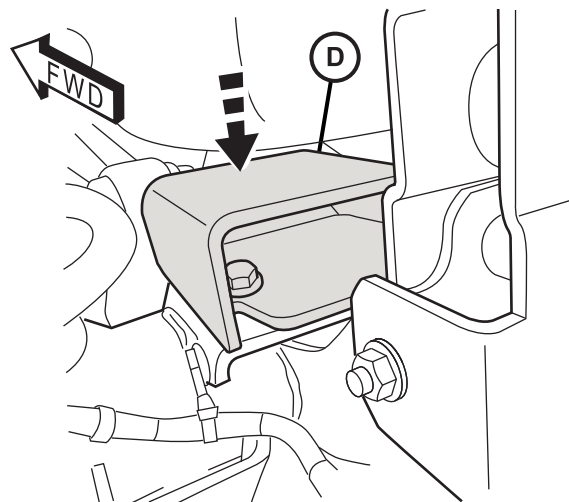

**64** REPEAT STEPS 59 THROUGH 63 ON DRIVER SIDE  
WITH BUMPER PAD (D)

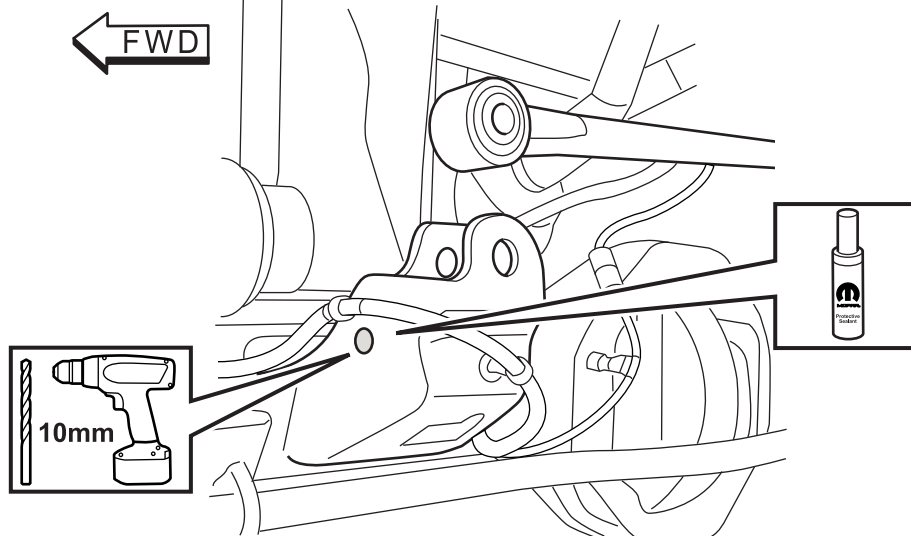

**65**

**ENLARGE HOLE WHERE CLIP WAS LOCATED. DE-BURR AND TREAT HOLE WITH RUST PREVENTER.**

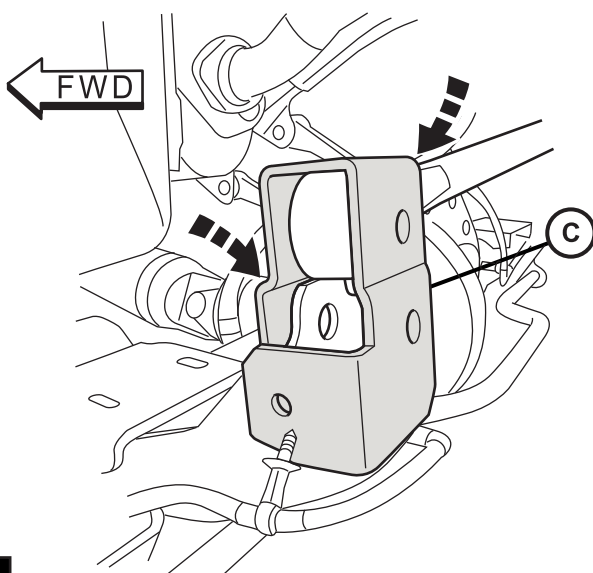

**66**

**MOUNT TRACK BAR BRACKET (C)**

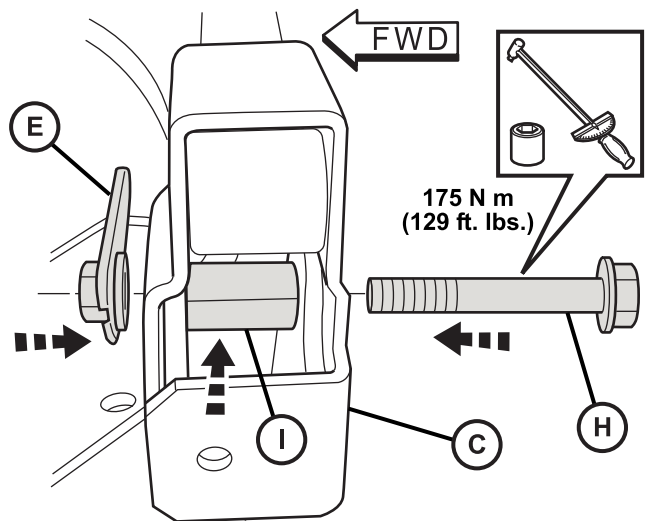

**67**

**INSTALL BOLT (H), NUT (E) AND SPACER (I)**

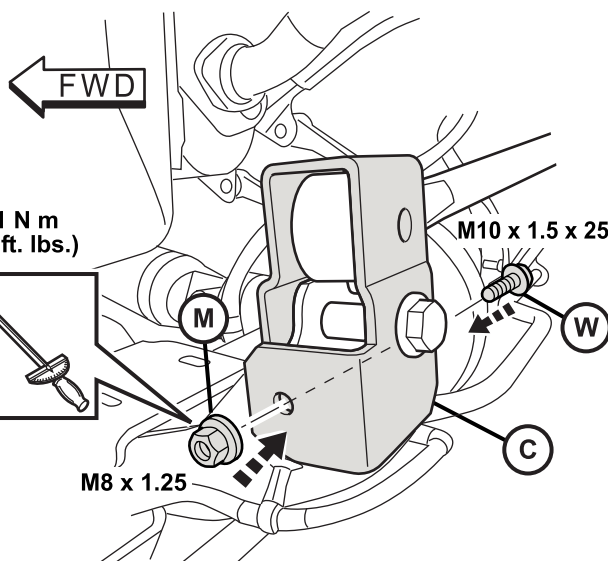

**68**

**INSTALL NUT (M) AND BOLT (W)**

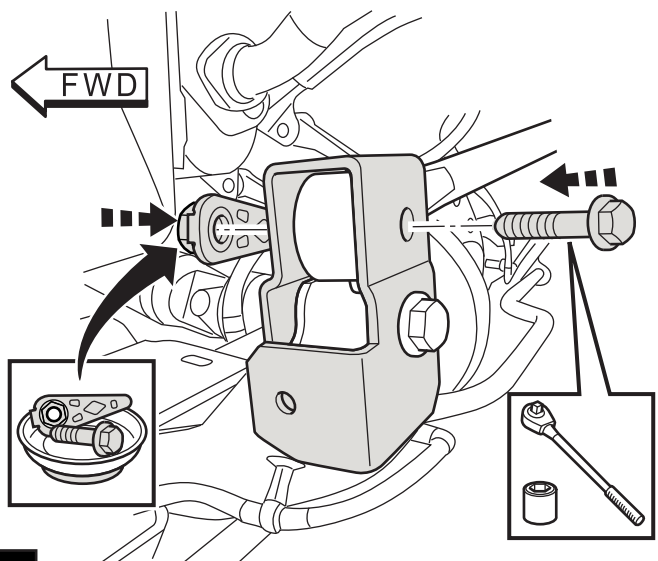

**69**

**REINSTALL TRACK BAR FASTENERS**

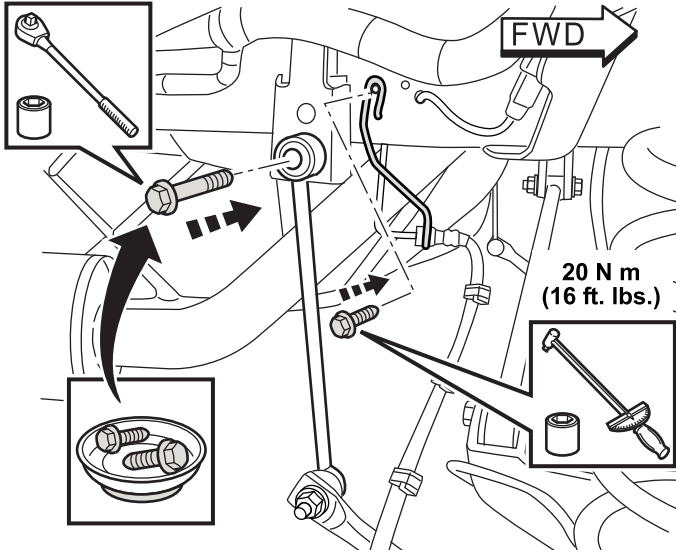

**70** REINSTALL STABILIZER LINK FASTENERS

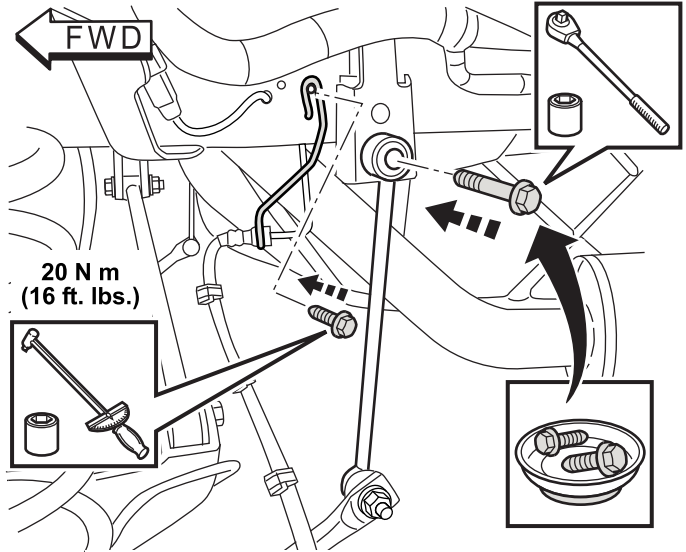

**71** REINSTALL STABILIZER LINK FASTENERS ON OPPOSITE SIDE

REVERSE STEPS 38 THROUGH 42  
TO REINSTALL ALL VEHICLE COMPONENTS

**72**

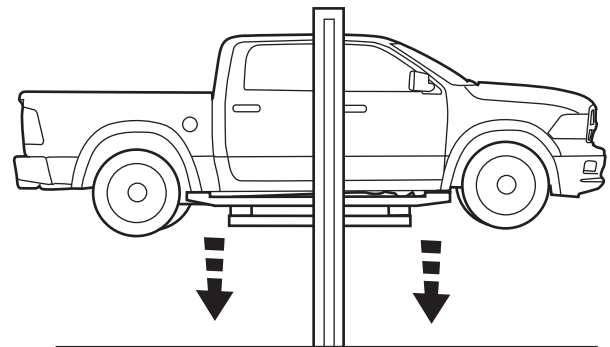

**73**

REFER TO SPECIFICATIONS ON THE FOLLOWING PAGES  
TO COMPLETE THESE INSTALLATION STEPS:

- 1) TORQUE VALUES
- 2) WHEEL ALIGNMENT
- 3) HEADLAMP ADJUSTMENT

**IMPORTANT: DO NOT APPLY FINAL TORQUE SPECIFICATIONS  
UNTIL VEHICLE IS ON THE GROUND**

**74**

## LIFT KIT TORQUE SPECIFICATIONS

PART DESCRIPTION	TORQUE N•m	TORQUE Ft. Lbs.
FRONT LOWER CONTROL ARM NUTS	100 + 145°	74 + 145°
FRONT STRUT ROD NUT	42	31
FRONT SHOCK ABSORBER LOWER BOLT	168	124
FRONT SHOCK ABSORBER UPPER NUT	77	57
FRONT STABILIZER BAR LINK LOWER NUT	100	74
FRONT UPPER CONTROL ARM BOLTS	176	130
FRONT UPPER BALL JOINT NUT - M14 x 1.5	35 + 180°	26 + 180°
FRONT TIE ROD END TO KNUCKLE NUT - M14 x 1.5	50 + 180°	37 + 180°
REAR SHOCK ABSORBER LOWER BOLT	140	103
REAR SHOCK ABSORBER UPPER BOLT	48	35
REAR STABILIZER BAR LINK UPPER BOLT	85	63
REAR UPPER CONTROL ARM FRONT BOLT	200 + 90°	148 + 90°
REAR UPPER CONTROL ARM REAR NUT	200 + 90°	148 + 90°
REAR LOWER CONTROL ARM REAR NUT	200 + 90°	148 + 90°
REAR LOWER CONTROL ARM FRONT BOLT	200 + 90°	148 + 90°
REAR BRAKE HOSE BRACKET BOLT	20	16
TRACK BAR AXLE BOLT TO BRACKET W/SPACER M14 x 1.5 x 90	175	129
TRACK BAR AXLE BOLT TO BRACKET	61	45
REAR BUMPER PAD BOLT - M10 x 1.5 x 25	61	45
REAR BUMPER PAD BOLT - M8 x 1.25 x 21	32	23
REAR SPRING SPACER NUTS - M8 x 1.25	32	23
WHEEL LUG NUTS	176	130

NOTE: IN ANY INSTANCE WHERE A BOLT IS THROUGH A RUBBER BUSHING,  
THE BOLT MUST BE TORQUED AT NORMAL RIDE HEIGHT

**TARGET ALIGNMENT SPECIFICATIONS**

**LEFT FRONT**

**CAMBER**  
 $0.00^\circ \pm 0.65^\circ$

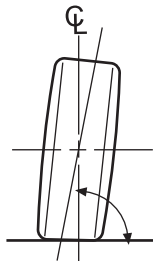

**RIGHT FRONT**

**CAMBER**  
 $0.00^\circ \pm 0.65^\circ$

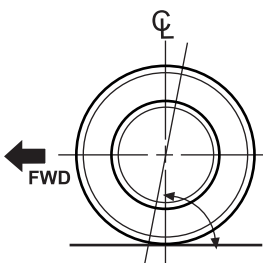

**CASTER**  
 $4.50^\circ \pm 0.65^\circ$

**CASTER**  
 $4.50^\circ \pm 0.65^\circ$

**TOE-IN**  
 $0.10^\circ \pm 0.20^\circ$

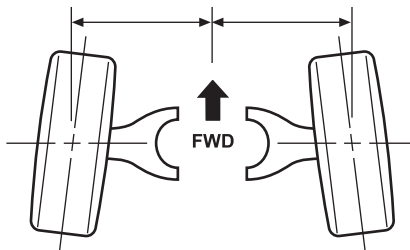

**TOE-IN**  
 $0.10^\circ \pm 0.20^\circ$

**THRUST ANGLE**  
 $0.0^\circ - 0.25^\circ$

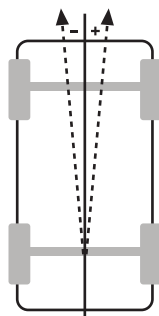

**TOTAL TOE-IN**  
 $0.10^\circ \pm 0.20^\circ$

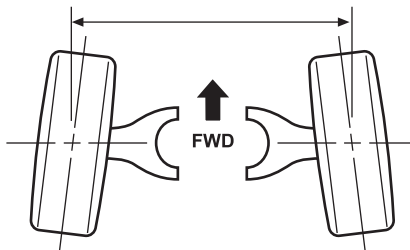

## HEADLAMP ALIGNMENT

1. Verify proper tire inflation pressures.
2. Verify that there is no extra weight load in the vehicle except for the driver.
3. The fuel tank should be FULL.
4. Prepare an alignment wall according to diagram below:

