

Environmental Impact Assessment – Part 1

Project Number: 44944
November 2011

UZB: SURGIL NATURAL GAS CHEMICALS

Prepared by Mott MacDonald for Uz-Kor Chemical

The environmental impact assessment is a document of the borrower. The views expressed herein do not necessarily represent those of ADB's Board of Directors, Management, or staff, and may be preliminary in nature. Your attention is directed to the "Term of Use" section of this website.

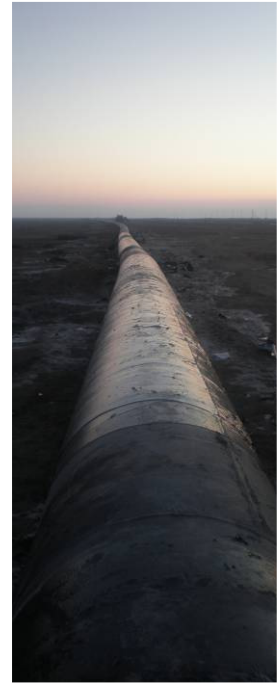

Surgil Project ESIA – Volume I

Non Technical Summary – Final

November 2011
Uz-Kor Gas Chemical



Surgil Project ESIA – Volume I

Non Technical Summary – Final

November 2011

Uz-Kor Gas Chemical

12th Floor, International Business Centre, 107B Amir Temur Str., Tashkent, Uzbekistan

Issue and revision record

Revision	Date	Originator	Checker	Approver	Description
A	27/06/11	Jamie Crawford 	Lucy Chapman 	David Boyland 	Advanced Draft
B	05/07/11	Christopher Mills 	Nik Stone 	Rachel Watson 	Advanced Draft
		Nik Stone 	Lucy Chapman 	David Boyland 	
C	02/08/2011	Christopher Mills 			Disclosure Draft
D	09/11/2011	Rachel Watson 	Lucy Chapman 	David Boyland 	Final incorporating ESIA updates

This document is issued for the party which commissioned it and for specific purposes connected with the above-captioned project only. It should not be relied upon by any other party or used for any other purpose.

We accept no responsibility for the consequences of this document being relied upon by any other party, or being used for any other purpose, or containing any error or omission which is due to an error or omission in data supplied to us by other parties

This document contains confidential information and proprietary intellectual property. It should not be shown to other parties without consent from us and from the party which commissioned it.

Content

Chapter	Title	Page
1.	Introduction	1
1.1	Overview _____	1
1.2	Who is Uz-Kor Gas Chemical? _____	1
1.3	Where Can I Find More Information About the Project? _____	2
2.	The Project	3
2.1	Why is the Project Needed? _____	3
2.2	What is the Project? _____	4
2.3	How were the Project Site and Technology Selected? _____	12
3.	Managing Environmental and Social Impacts	14
3.1	What are the Project activities that could affect the environment and people? _____	14
3.2	How was the Project assessed and what were the findings? _____	14
3.3	Cumulative Impacts with Other Projects _____	31
3.4	How Uz-Kor will manage environmental and social impacts? _____	32

1. Introduction

1.1 Overview

The purpose of this non-technical summary (NTS) is to present in clear, simple and in as concise a manner as possible the main findings and conclusions of the Environmental and Social Impact Assessment (ESIA) undertaken for the construction, operation and decommissioning of the Surgil Project (the Project).

The Project will be developed by the Uzbek-Korean Joint Venture (JV) "Uz-Kor Gas Chemical" LLC (hereafter referred to as 'Uz-Kor'). The Project includes among other things, the development, production and transportation of hydrocarbons from the Surgil gas field (the 'Surgil Field'), the design, construction and operation and maintenance of a gas chemical complex to be located at Akchalak on the Ustyurt Plateau and the sale (including export) of processed gas, condensate and petrochemical products.

Uz-Kor intends to approach the Asian Development Bank ('ADB'), Korean Export Credit Agencies and other commercial banks to provide assistance for (i) existing facilities and / or business activities that already exist and will form part of the future Project proposed for financing; and (ii) the development of the gas chemical complex on sites that have been mostly allocated prior to lender consideration of the Project. This work includes the preparation of an international-quality Environmental and Social Impact Assessment (ESIA) to support obtaining international finance for the Project. It builds upon the national environmental assessment process which has been contracted separately by Uz-Kor.

In compliance with national Environmental Impact Assessment (EIA) requirements, a Stage 1 EIA (the Concept Statement on Environmental Impact) was undertaken in 2006-2007 by UzLITIneftgaz. This assessment, conducted in two parts, encompassed the construction of all Project components, including the Surgil Field, gas and condensate pipelines and the gas chemical complex. Approval from the state regulator Glavgosecoexpertiza for the Stage I EIA was granted in February 2007. The Glavgosecoexpertiza determined that a Stage II EIA was not required for the Surgil Field and pipeline components of the Project; however one was required to be undertaken for the gas chemical complex. This was completed by UzLITIneftgaz in 2009 and this Statement on Environmental Impact was approved by the Glavgosecoexpertiza on 16 July 2009. Stage III of the national EIA process is yet to be completed for the Project and is required to be submitted to the Glavgosecoexpertiza before operational activities commence.

Uz-Kor has appointed Mott MacDonald Limited (MML) to assist them in completing a full ESIA and associated Environmental and Social Management Plan (ESMP) to international standards for the Project, in compliance with the Equator Principles, International Finance Corporation (IFC) environmental and social performance standards and guidelines and ADB environmental and social safeguards.

1.2 Who is Uz-Kor Gas Chemical?

In March 2006, a memorandum of understanding was signed between the state-owned holding company of Uzbekistan's oil and gas industry, Uzbekneftegaz (UNG) and Korean Gas Corporation ('KOGAS') for the realization of the Project. The Project was subsequently supported by an Uzbekistan Presidential Decree in February 2008 leading to the formation of the Uz-Kor in May 2008.

Uz-Kor is a joint venture between UNG, KOGAS, Honam Petrochemical Corporation ('Honam'), and STX Energy Co. Ltd. ('STX') (collectively "the Sponsors"). The Sponsors intend to own and continue the development of the Surgil Field and to develop, build and own the gas chemical complex facility.

1.3 Where Can I Find More Information About the Project?

Consultation has also been undertaken by MML at the outset of the ESIA process and during preparation of the ESIA. Future consultation and disclosure events will include the communication of the draft ESIA, including this NTS, and disclosure of the final ESIA report. Uz-Kor will make the full ESIA report available on its website (www.uz-kor.com) as well as holding a printed copy for consultation at its head office in Nukus, the Ustyurtgaz offices in Kungrad, the Hakimyat offices at Kungrad and Muynak and the Aksakal offices in Akchalak.

To support the international ESIA process, MML has produced a Public Consultation and Disclosure Plan (PCDP) that acts as a strategic document for planning a comprehensive and culturally appropriate approach to consultation and disclosure for the lifecycle of the Project. This document is presented in Volume III of the ESIA.

In addition to local communication, the draft ESIA will be published by the ADB on the dedicated website www.adb.org.

The key channels identified for communicating information to interested parties are as follows:

- Disclosure within the local communities of the draft ESIA report;
- Ongoing media communications;
- Ongoing stakeholder meetings during construction and operation;
- Dedicated project Community Liaison Officer;
- Community investment activities;
- Monitoring reports; and
- Annual reports.

In addition to the formal consultation events and periods for comments on the ESIA, questions and comments can be addressed to Uz-Kor via the contact details presented in Table 1.1.

Table 1.1: Project Proponent Contact Details

Project Proponent	Information
Name of Company	Uz-Kor Gas Chemical LLC. ("Uz-Kor")
Address (Head Office)	12th Floor, International Business Centre, 107B Amir Temur Str., Tashkent, Uzbekistan
Telephone	(+99871) 238-92-23
Fax	(+99871) 238-92-24
Address (Registered Office)	133A, Dostnazarov street Nukus city Republic of Karakalpakstan Republic of Uzbekistan
Telephone	+998 90 727 9277
Fax	+998 61 222 21 87
E-mail	uzkorgaschemical@gmail.com
Website	www.uz-kor.com

2. The Project

2.1 Why is the Project Needed?

Uzbekistan's main economic focus to date has been the cotton industry which has resulted in a large proportion of the country's land being intensely cultivated in irrigated river valleys to produce cotton. Regionally, Karakalpakstan has also historically heavily relied on the fishing industry of the Aral Sea. The intensive irrigation practices required to support the cotton industry however has resulted in the Aral Sea steadily shrinking since the 1960s. As a result, the region's once prosperous fishing industry has significantly declined, bringing unemployment and economic hardship to the remaining communities in the area.

Investment has the potential to improve not only economic standards, but also social and environmental standards in Uzbekistan and Karakalpakstan. Uzbekistan possesses significant oil and gas energy resources and recent investment by other countries in its gas and oil industry offers economic diversification and growth prospects for the country. Development of these energy resources will generate viable export opportunities and help reduce Uzbekistan's reliance on importation of hydrocarbon products.

Overall, the Project can be concluded to fulfil the following needs:

- Inward investment from outside Uzbekistan;
- Injection of revenue to the regional and national economy that will provide funds for supporting wider socio-economic development goals in areas such as agriculture;
- Increased production of plastics pre-cursors (PP and HDPE) that will reduce Uzbekistan's reliance on imports of these materials as industrial sectors that use them are developing;
- Conversion of energy resources (oil and gas) into stable product that can be readily exported into the world market to generate important export revenue;
- Addition of valuable economic activity into the Karakalpakstan region after the decline of the fishing industry caused by the retreat of the Aral Sea;
- Diversification of the local economy from agriculture and reduction of reliance on a single economic sector; and
- Regional funds that can support improvements to irrigation system thereby increasing efficiency of water use that could ultimately assist in allowing recharge of the Aral Sea.

2.2 What is the Project?

2.2.1 Project Overview

The aim of the Project is to contribute to the broader development goals of the Republic of Uzbekistan through (i) the expansion of the Surgil Field to extract natural gas; and (ii) subsequent gas processing to produce gas, gas condensate and establish polyethylene and polypropylene production for use and export.

The Project is located within the Ustyurt region of the Republic of Karakalpakstan, a semi-autonomous area in the west of the Republic of Uzbekistan. Karakalpakstan borders with the Republic of Kazakhstan in the north and west, the Navoi region in the east, the Khorezm and Bukhara regions in the south-east and with Turkmenistan to the south. The location of the Project within Uzbekistan and the wider region is illustrated within Figure 2.1.

Figure 2.1: Location of Project Within Uzbekistan



The Project will comprise of three main components:

- **Upstream** - Drilling and development of gas production wells and associated production infrastructure at the Surgil Field including expansion of the existing complex gas treatment unit (CGTU) for the removal of hydrocarbon condensate and water from the gas.
- **Pipelines** - Construction and operation of below ground gas and condensate pipelines to connect the Surgil Field to the new Ustyurt Gas Chemical Complex (UGCC). Further connecting pipelines will be constructed to two other gas fields within the Aral Sea Basin, the East and North Berdakh Gas Fields.
- **Downstream** - Construction and operation of the UGCC and associated infrastructure (i.e. workers camp, rail connection, road connection, raw water supply line connection, sales gas line, wastewater line and electrical power line connection).

The above Project components assessed within the ESIA are shown in Figure 2.2.

254793/RGE/GEV/01/B 04/08/2011

P:\Glasgow\GBD\RGE\GEV\Projects\254793 Surgil ESIA\9.0 Working Files\ESIA Report\Rev D - Response to ADB's 2nd comments\Final Draft\Surgil ESIA Volume I (NTS) Final Draft.doc

Figure 2.2: Main Project Components

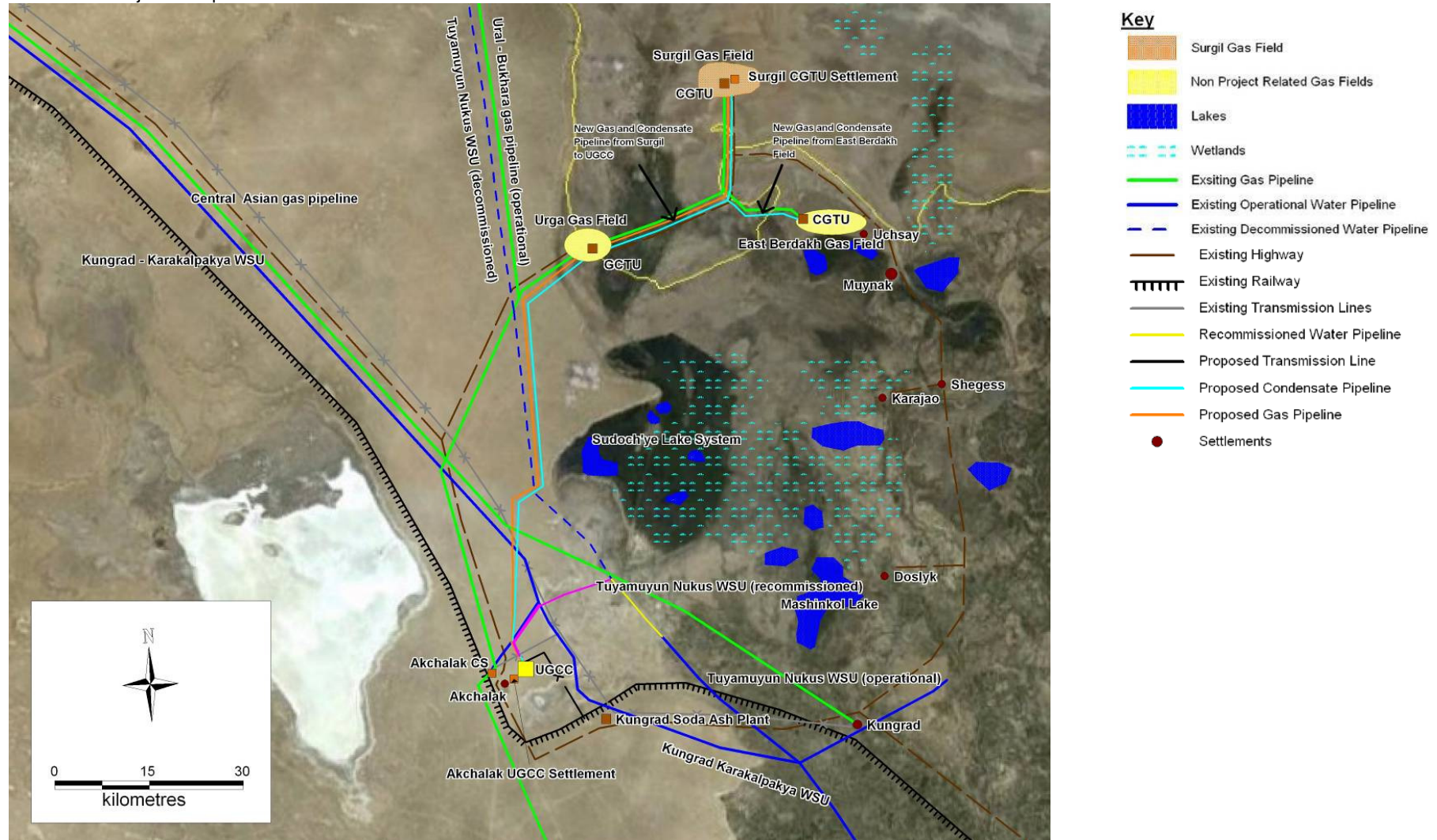

Source: JV Uz-KorGasChemical LLC

The Project will also receive gas and condensate from the East and North Berdakh fields, located approximately 25 km from the Surgil Field. These fields will be connected to the UGCC via new gas and condensate pipelines which are included for consideration in the ESIA.

As development and operation of the East and North Berdakh fields is not dependent upon realisation of the Project, in line with IFC Performance Standard 1, they are not classified as associated projects to the Project, and as such are not included in the scope of the ESIA. UNG has however undertaken to operate these fields in a manner which complies with the environmental and social requirements of the Lenders. This undertaking is considered to be in line with the draft IFC requirements influencing where possible interactions with Project product suppliers.

2.2.2 Upstream Component – Surgil Field

The development of the Surgil Field has progressed to date under the responsibility of Ustyurtgaz (UG), a subsidiary of UNG. Ownership will transfer to Uz-Kor with the realisation of the Project. Much of the Surgil Field infrastructure, including a fully operational CGTU constructed in 2007, is already in existence and at March 2011, the Surgil Field included 28 operational wells, with further drilling activities ongoing.

The proposed Project intends to develop the Surgil Field to a total of 133 wells between 2007 and 2020. Gas from the Surgil Field wells will be transferred to the existing Surgil CGTU (either via Gas Gathering Stations or routed directly) where hydrocarbon condensate and water is removed. The Surgil Field is anticipated to have a production life of approximately 40 years and over the period of production, a total of 94.8 billion m³ of gas and 2.3 million tons of condensate will be extracted.

To support this expansion, the existing CGTU will be expanded within the existing site boundary to enable it to go from handling the current 6 million m³ per day of gas to 9 million m³ of gas per day (approximately 3 billion m³ per annum). An operational workers settlement (living quarters for 72 people) to support the expansion and operation of the Surgil Field is planned for 2011.

A number of other related infrastructure and facilities will also be developed or upgraded as part of the upstream components including:

- Infrastructure for water supply and discharge;
- Heat and electricity supply infrastructure;
- Communication lines; and
- Upgrade of internal site roads within the Surgil Field.

The gas wells will be drilled using mobile drilling platforms to a maximum depth of 2,950 metres. Once a gas well has been drilled it is cased and completed. The drilling process will use drilling fluids/muds to remove drilled cuttings (rock chippings) from the wellbore and control of formation pressures. The drilling fluids also seal permeable formations, maintain well bore stability, cool and lubricate the drill bit, and transmit hydraulic energy to the drilling tools and bit. Both water-based drilling fluids (WBDF) and non-aqueous based fluids (NABF) (with bentonite clays as a thickener) will be utilised and will require disposal by the Project.

2.2.3 Pipelines

A new gas (1,020 mm diameter) pipeline and a condensate (168 mm diameter) pipeline will be constructed in order to connect the Surgil Field to the UGCC as illustrated in Figure 2.2. They will be 115 km in length

254793/RGE/GEV/01/B 04/08/2011

P:\Glasgow\GBD\RGE\GEV\Projects\254793 Surgil ESIA\9.0 Working Files\ESIA Report\Rev D - Response to ADB's 2nd comments\Final Draft\Surgil ESIA Volume I (NTS) Final Draft.doc

and the condensate pipeline will be built immediately in parallel to the new gas pipeline. The minimum below ground depth for all pipelines will be 1.5 m and valve stations will be installed at regular intervals along the pipelines to allow automatic or manual operation of safety valves.

Gas and condensate from the East Berdakh field will join the new Surgil gas and condensate pipelines approximately 21 km south of the Surgil CGTU via new 24 km gas and condensate pipelines respectively.

The pipeline route will follow existing pipelines routes where possible. At the Urga crossing, the new gas and condensate pipelines will pass up the escarpment parallel to the existing Surgil and East Berdakh gas export pipelines in order to minimise the disturbance to the escarpment. On the Ustyurt plateau the intention is to maintain a minimum 2 km separation between the pipelines and the edge of the escarpment along its route in order to minimise risk to the escarpment and the Sudoch'ye nature reserve at the foot of the escarpment.

At the UGCC, a bypass will allow gas to pass directly to the Akchalak Gas Compressor Station, and into the Central Asia pipeline should it be necessary for operational or maintenance reasons. A schematic of the pipeline system is shown in Figure 2.3 to illustrate the proposed operational arrangements.

Figure 2.3: Pipeline Arrangement – Overview

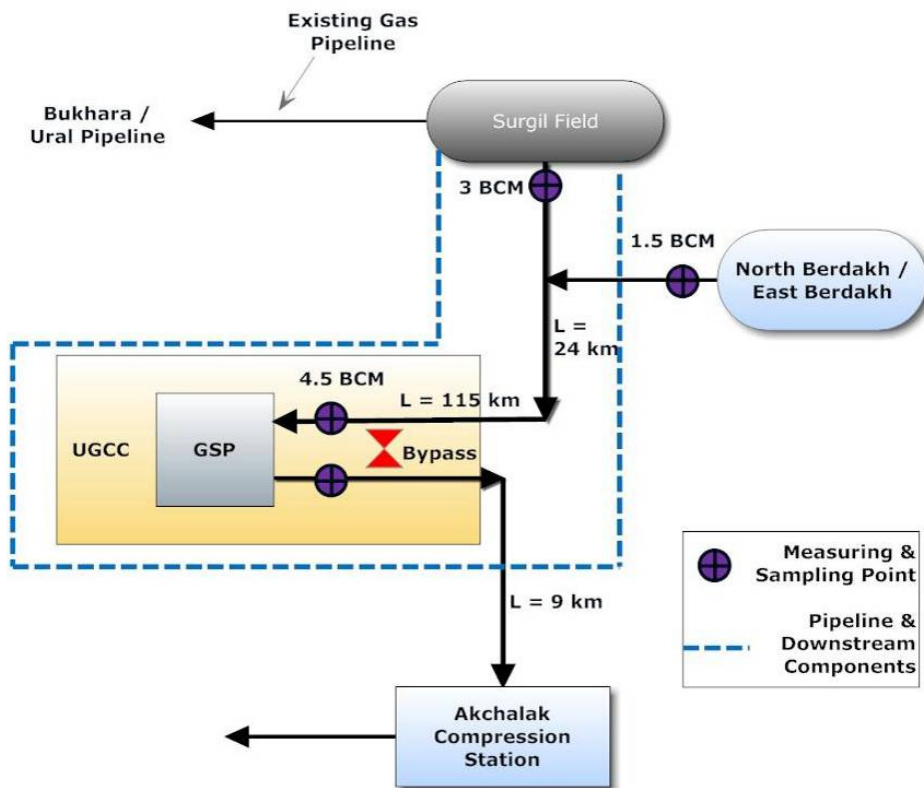

Source: Uz-Kor

The pipelines will have the following:

- Pipeline Inspection Gauge (PIG) reception facilities at either end of the pipeline for pipeline maintenance activities;
- Passive protection of gas pipeline against soil corrosion will be provided by anti-corrosion coating;
- Protection of pipes against underground corrosion will be by electrochemical protection system with continuous cathodic polarisations of pipe surface;
- To provide the electrochemical protection, a 10 kV transmission line will run the length of the pipeline route (115km) supported on concrete poles; and
- Communication System - a fibre-optic communication system will be laid in parallel to the entire pipeline route. The communication network will allow automation and control of the pipeline and also facilitate communication between the UGCC and the Surgil CGTU.

2.2.4 Downstream Component – UGCC

The new UGCC will be designed to receive natural gas and un-stabilised condensate from the gas fields by pipeline, in addition to some condensate which will be imported by rail. This will then be processed in the UGCC to form high-density polyethylene (HDPE) and polypropylene (PP) pellets. These pellets will then be exported to international and national markets. A proportion of stabilised condensate will be exported by rail to other chemical facilities in the Aral Region. Sales gas, pyoil and pygas will also be final products from the UGCC for onward sale.

The UGCC will occupy undeveloped land located on the Ustyurt Plateau approximately 115 km to the south of the Surgil Field. The UGCC consists of the below process activities culminating in the production of HDPE and PP pellets, as illustrated in Figure 2.4:

- Gas separation plant (GSP);
- Ethylene plant;
- HDPE plant;
- PP plant; and
- Supporting utilities and offsite (U&O) infrastructure related to the above process plants.

The UGCC will process up to 3 billion cubic meters (bcm) of gas per annum from the Surgil Field and 1.5 billion m³ per year of gas from other gas fields. The production levels of the new UGCC plants will be:

- GSP: 4.5 bcm (3,345 kta) of gas and 162,000 tons per year of condensate;
- Ethylene plant: 387,000 tons per year of ethylene and 83,000 tons per year of propylene;
- HDPE plant: 387,000 tons per year (2 lines); and
- PP plant: 83,000 tons per year of PP.

Figure 2.4: UGCC Process Overview

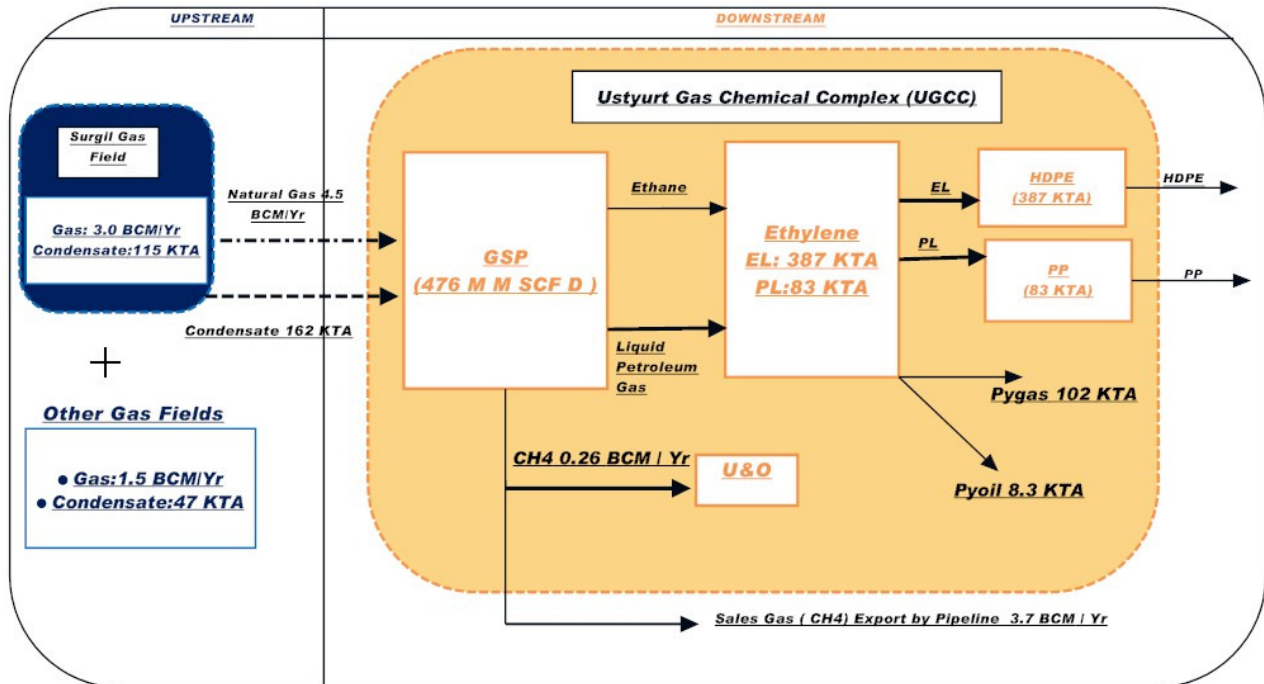

Source: Mott MacDonald

KEY

GSP – Gas Separation Plant

EL - Ethylene

PL - Propylene

U&O – Utilities & Offsites

HDPE – High Density Polyethylene

PP - Polypropylene

bcm/yr – billion cubic metres per year

KTA – kilo tonnes per annum

MMSCFD – million standard cubic feet per minute

A number of related infrastructure and facilities will also be developed as part of the utilities and offsite facilities or external project infrastructure, including:

- Main water conduit from Kungrad - Karakalpakya water supply pipeline;
- Back-up water conduit from the Tuyamuyun - Nukus water supply pipeline;
- Wastewater treatment system and wastewater pond and pipelines for transfer of wastewater and recycled water to and from the UGCC;
- Solid and domestic waste storage area;
- Railroad approach line from Kyrkkyz station to the UGCC (7km in length);
- External power supply (110 kV transmission line) from the Kungrad Soda Ash Plant Substation (12km in length);
- Sales gas pipeline from the UGCC to Akchalak Gas Compressor Station (9km in length);
- Road connection to the UGCC from the Kungrad – Beyneu (A-380) highway (5km in length); and
- Dwelling settlement.

A map of the UGCC and related infrastructure is shown in Figure 2.5.

2.2.5 Schedule

Construction and drilling operations for the Surgil Field and pipeline components of the Project commenced in 2007. Drilling of the gas wells will occur until 2020, with GGSs also constructed periodically throughout this period as wells are developed. It is anticipated that a maximum of five drilling rigs will be operating at any one time. Expansion of the CGTU is expected to commence in 2011 and be completed by 2013.

The construction of the gas and condensate pipelines is programmed to be completed over a 12 month period between 2012 and 2013.

Construction and development of the UGCC is expected to commence in 2011. The overall schedule for construction of the UGCC component of the Project will depend on the delivery period of a number of major plant items and the UGCC is anticipated to come into operation in late 2014 / early 2015.

The total construction periods for each of the main parts of the UGCC are summarized as follows:

- U&O: 36 months;
- GSP: 36 months;
- Ethylene plant: 40 months; and
- Polymer plants: 40 months.

Figure 2.5: Overview of UGCC and related infrastructure

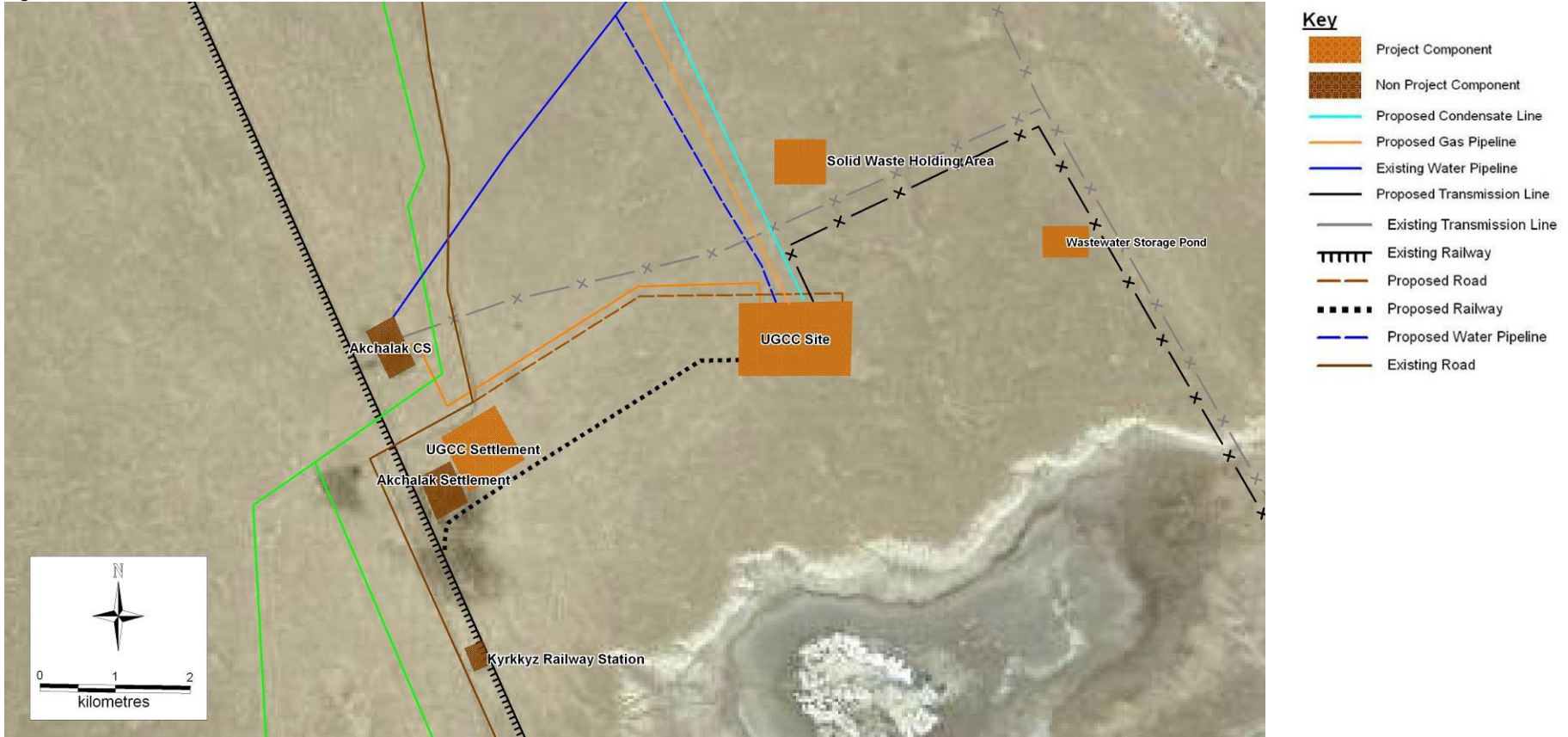

Source: MML with Google Earth basemap under license

2.3 How were the Project Site and Technology Selected?

The Project development and the ESIA process included consideration of alternative sites and technologies.

2.3.1 Gas Field and Pipeline Routing

The location of oil and gas extraction enterprises are intrinsically dictated by the geographical location of the hydrocarbon reserves. To an extent, therefore, the location of development of the supply gas field for the Project is subject to limited comparison with alternatives. Nonetheless, the Project proponents considered a variety of associated factors prior to electing to exploit the hydrocarbon reserves of the Surgil Field, including:

- Probable hydrocarbon reserve and historically discovered reserves;
- Field remoteness from transport communications and processing centres;
- Depth of occurrence of productive horizons;
- Local environmental quality; and
- Other factors determining labour input and material resources required for hydrocarbon exploration, extraction and transportation.

Following evaluation of the above factors, the decision was made that the Surgil Field offered the optimum location for natural gas supply for the Project.

Selection of an appropriate pipeline route from the Surgil Field to the UGCC included the following routing criteria to minimise potential impact:

- Maximising the use of the existing utility corridors. This measure has resulted in a total of 78 km of the 115 km pipeline (68%) utilising existing pipeline corridors which will significantly reduce the amount of undisturbed ground through which the pipelines will need to be constructed. This includes utilising the existing Urga pipeline crossing which will minimise the disturbance of the geological structure of the escarpment; and
- Where the pipelines had to be routed through undisturbed land a route was selected that avoided or minimised disturbance of sensitive environmental or social features. The main consideration for the pipeline route has been to avoid potential impact on the escarpment at the edge of the Ustyurt Plateau and therefore the route avoided new pipelines being within 2 km of the escarpment.

2.3.2 UGCC

Two locations were considered as potential sites during site selection studies for the UGCC. Both sites met a number of the key site selection criteria including proximity to transport, water supply and electricity supply infrastructure and local labour. Certain factors however favoured the selection of the chosen location near the Akchalak settlement on the Ustyurt Plateau, including:

- The chosen site offers sufficient land and flexibility so as to ensure that there should be no impacts upon Project schedule resulting from problems accessing equipment during construction and commissioning stages;
- The land is low relief, allowing relatively straightforward construction practice;
- Ground conditions would permit easier ground preparation resulting in significantly lower cost of construction
- Favourable groundwater depth would limit the potential for complications during plant construction;

- Proximity to the existing buried gas pipeline infrastructure (Central Asian and Bukhara-Ural) and other utilities. The connections to these utilities can largely use existing utility corridors thereby reducing the need to develop virgin ground.

2.3.3 Technology selection

Drilling operations will be conducted using internationally accepted drilling techniques. For the Surgil Field, the fractured nature of the strata and distribution of the gas reserves means that horizontal drilling is not effective in maximising the gas extraction levels and therefore vertical drilling techniques will be used. Although vertical drilling will result in a larger number of wells, the environment of the Surgil Field is already degraded and as such there is no driver for horizontal drilling on environmental grounds.

For all major process stages within the UGCC Uz-Kor has sought tenders from established global suppliers with the aim of selecting equipment and plant that is proven and is in use at similar installations around the world. This approach has been used in order to ensure the plant design is optimised for the required technical performance, local conditions and environmental, health and safety standards.

The scale of the proposed UGCC plant is well within the commercially proven range and the technology employed at all stages of the complex is mature and well understood. This, added to the fact that the technology providers invited to tender are well established and reputable, provides confidence in the technology procurement process such that the technology selected will be well suited to the project and capable of meeting all required environmental, health and safety standards.

3. Managing Environmental and Social Impacts

3.1 What are the Project activities that could affect the environment and people?

It is recognised that a project of this scale and duration has the potential to impact the environment and the community, both in a positive and negative way. The activities that could cause the most important effects include:

- Social impacts associated with:
 - Employment generation, including quotas for indigenous Karakalpak peoples and women;
 - Workers skills and well-being;
 - Community health, safety and well being;
 - Land allocation / re-allocation; and
 - Community investment;
- Direct and indirect impacts on ecology;
- Impacts on water resources and water quality;
- Materials and waste management;
- Impacts to ground conditions;
- Noise and vibration effects;
- Traffic and transportation impacts;
- Landscape and visual effects;
- Air quality impacts;
- Greenhouse gases emissions; and
- Impacts to cultural heritage and archaeology.

3.2 How was the Project assessed and what were the findings?

A thorough appraisal has been undertaken for potential impacts arising from the Project development, including the above issues; the appraisal has included a detailed Social Impact Assessment and Environmental Impact Assessment (collectively presented as an ESIA). The assessment included:

- Establishment of the baseline to understand current conditions at and around the proposed Project sites;
- Prediction of impacts, using, where relevant, advanced modelling tools; and
- Identification of mitigation measures to be included in the design, procedures, development and management of the Project.

The appraisal process was supported by local consultation undertaken to ensure that Uz-Kor understands and has incorporated the concerns of local people from the surrounding communities into the process.

The significance of an impact is described based on sensitivity of project affected persons / environment and magnitude of impacts. Where possible, impact magnitude and sensitivity are described with reference to legal requirements, accepted scientific standards or accepted impact assessment practice and/or social acceptability. Where the ESIA found that the project could cause moderate to substantially significant impacts then actions or procedures (referred to as mitigation measures) have been developed to avoid, reduce or otherwise mitigate the effects and reduce their significance. A great number of potential impacts can either be avoided or reduced through mitigation; however, some residual environmental impacts may be unavoidable. Each chapter of the ESIA has assessed whether residual impacts, either beneficial or adverse, remain after mitigation. A summary of the key findings of the appraisal process, the residual

impact and the main mitigation measures identified for each social and environmental impact of significance is summarised in Table 3.1 and Table 3.2 below.

Table 3.1 and Table 3.2 summarise impacts and mitigation measures for each social and environmental aspect considered relating to the following phases of the Project (as relevant):

- Construction of the Surgil Field (including drilling activities), UGCC and connecting pipelines
- Operation (relating to the operation of the Surgil Field, UGCC, and connecting pipelines);
- Decommissioning (relating to the post operation of the Surgil Field, UGCC and connecting pipelines).

Table 3.1: Summary of Social Impacts and Mitigation Measures

Phase / Project Component	Activity	Impact	Impact Significance	Mitigation / benefit enhancement Measures	Residual Significance
Employment Generation					
Construction and drilling - all Project components	Recruitment	Short to medium term employment generation	Beneficial impact of minor to moderate significance	Local skills utilisation and development Apprenticeships Local Procurement Financial Management Seminars Staff grievance mechanism Workers' Code of Conduct Recruitment plan Training of all international workers in cultural sensitivities of Ethnic Karakalpak and Kazakh communities (via brochures)	Beneficial impact of moderate significance
Operation - all Project components	Recruitment	Generation of longer term permanent employment	Beneficial impact of moderate significance	Project commitments to workers' rights in accordance with international standards Local skills utilisation and development Apprenticeships Workers' Code of Conduct Recruitment plan Staff grievance mechanism Training of all international workers in cultural sensitivities of Ethnic Karakalpak and Kazakh communities (via brochures)	Beneficial impact of moderate significance
Impacts on Ethnic Population					
Construction, drilling - all Project components	Ethnic people interaction	Potential impacts on Karakalpaks and ethnic minorities	Beneficial impact of minor to moderate significance	Above noted employment generation mitigation / benefit enhancement measures Development of employment policy which captures employment quotas proportional to ethnic distribution in the districts / region Employment quota to apply to local supplier and contractors working on the Project Monitoring of performance against the quota	Beneficial impact of moderate significance
Operation - all Project components	Long term sustainable economic development of Karakalpakstan	Technical and other skills development for Karakalpak ethnic peoples	Beneficial impact of minor to moderate significance	Longer term more sustainable livelihoods Tax revenues for the Karakalpakstan region	Beneficial impact of minor to moderate significance

Phase / Project Component	Activity	Impact	Impact Significance	Mitigation / benefit enhancement Measures	Residual Significance
Impacts on Women					
Construction, drilling and Operations - all Project components	Employment opportunities for women	Specific employment quotas for women - Short to medium term employment generation	Beneficial impact of minor to moderate significance	Development of employment policy with captures the female employment quota Employment quota to apply to local supplier and contractors working on the Project Monitoring of performance against the quota	Beneficial impact of minor to moderate significance
Land Allocation					
Construction and drilling – all Project components	Land allocation and re-allocation for industrial purposes	Potential physical or economic displacement	Insignificant	Continue to obtain land allocation certificates in line with legislation and maintain dossier of land acquisition	Insignificant
Impacts on the Well-being of Workers on Site and in Camps					
Construction and drilling - all Project components	Working / living on site / in camps	Risks to health, safety and security of workers on site and in construction accommodation	Adverse impact of moderate significance	Project commitments to workers' rights in accordance with international standards Recruitment policy to promote equal opportunity for women, Karakalpaks and ethnic minorities Occupational H&S management and training Contractors to undertake comprehensive HAZOPS Provision of accommodation to international standards Tuberculosis testing and immunisation Cultural sharing & tolerance training especially in relation to the cultural practices of Karakalpaks and Kazakhs Labour grievance mechanism	Insignificant
Operation - all Project components	Working on site / living in operational camps	Risks to health, safety and security of workers and families on site and in operations accommodation	Adverse impact of moderate significance	Implement the relevant measures as for construction above.	Insignificant
Post operation/ decommissioning – all Project components	Retrenchment	Loss of employment and reduction in income security of workers	N/A	Development and disclosure of retrenchment plans.	
Impacts on Community Health, Safety, Security and Well-being					
Construction and drilling - all Project components	Project site construction and worker	Risk to community health, safety,	Adverse impact of minor	Site security measures Emergency preparedness and response plan	Insignificant

254793/RGE/GEV/01/B 04/08/2011

P:\Glasgow\GBD\RGE\GEV\Projects\254793 Surgil ESIA\9.0 Working Files\ESIA Report\Rev D - Response to ADB's 2nd comments\Final Draft\Surgil ESIA Volume I (NTS) Final Draft.doc

Phase / Project Component	Activity	Impact	Impact Significance	Mitigation / benefit enhancement Measures	Residual Significance
components	activities	security and well-being from site activities and workers	significance	Cultural sharing & tolerance training especially in relation to the cultural practices of Karakalpaks and Kazakhs HIV / AIDS awareness raising	
Operation - all Project components	Project site operation and maintenance activities	Risk to community health, safety, security and well-being from operational site activities	Adverse impact of minor significance	Implement the relevant measures as for construction above	Insignificant
Operation of UGCC	Project site operation and maintenance activities	Risk to community health, safety, security and well-being from operational site activities	Beneficial impact of minor significance	Provision of skills training to local people Provision of additional community facilities and services in the Akchalak Settlement HIV / AIDS awareness raising Free Tuberculosis testing for local community Deployment of Gas Rescue Squad Emergency preparedness and response plan	Beneficial impact of minor significance
Infrastructure Development					
Construction and drilling - all Project components	Infrastructure development	Enhanced workers accommodation at sites and additional community facilities in the Akchalak Settlement	Beneficial impact of moderate significance	Provision of accommodation to international standards Implementation of Community Investment Programme (CIP)	Beneficial impact of moderate significance
Community Investment					
Operation - all Project components	Industrial development revenue / national energy security.	Increased revenues to aid implementation of improved local infrastructure and community development projects	Beneficial impact of moderate significance	Implementation of CIP	Beneficial impact of moderate significance
Decommissioning					
Decommissioning - all Project Components	Post operation / De-commissioning of project facilities	Depletion of gas resources	N/A	Hydrocarbon reserves management plan	
		Redundant facilities and unused land	N/A	Sites made safe and returned to initial status or improved in terms of amenity	
		Retrenchment of staff	N/A	Retrenchment planning	

Table 3.2: Summary of Environmental Impacts and Mitigation Measures

Phase / Project Component	Activity	Impact	Impact Significance	Mitigation Measures	Residual Significance
Ecology					
Construction, Drilling and Decommissioning – all Project components	Construction, drilling and decommissioning activities and introduction of workers to area	Hunting of bird and mammal species by workers, including IUCN species	Adverse impact of minor to moderate significance	Introduction of hunting ban Awareness programme Appointment of Wildlife Warden Construction ecological monitoring programme Biodiversity Action Plan	Adverse impact of minor significance (pipelines & UGCC) or Insignificant (Surgil Field)
		Potential introduction of invasive flora and fauna effecting natural habitats	Adverse impact of minor significance	Adherence to IPIECA guidelines on prevention & management of alien species. Ongoing management through Decommissioning EMP	Insignificant
		Noise and light disturbance to birds and mammals.	Adverse impact of minor significance	Best practice standards to minimise noise and light pollution. Cessation of continuous flaring at the Surgil Field. Minimise traffic. Avoid excessive off-road access. No night time work.	Insignificant
		Loss of natural Haloxylon communities (Surgil Field)	Adverse impact of minor to moderate significance	Minimise working area Minimise area of habitats loss Re-instatement of habitats	Adverse impact of minor significance
Construction, Drilling and Decommissioning – Surgil Field and pipelines	Vegetation clearance, earthworks, and spoil disposal during construction	Loss of open drifting sand habitats	Adverse impact of minor significance	Minimise working area Minimise area of habitats loss Biodiversity Action Plan	Insignificant
Construction and Decommissioning – Pipelines and UGCC	Construction in vicinity of protected site (Sudoch'ye Lake)	No direct impact on Sudoch'ye Lake. Potential increased hunting and disturbance to birds associated with lake	Adverse impact of moderate significance (UGCC) to large significance (pipelines)	Introduction of hunting ban Awareness programme across all employees Clear demarcation/signage along site boundaries nearest the Sudoch'ye Lake restricting access Biodiversity Action Plan	Adverse impact of minor significance (pipelines) or Insignificant (UGCC)
	Vegetation clearance, earthworks, soil compaction and spoil disposal	Temporary loss of habitats on the Ustyurt Plateau and escarpment	Adverse impact of minor to moderate significance	Use of existing infrastructure corridors and crossing of Ustyurt escarpment to minimise natural habitat loss. Minimise working area Re-instatement of habitats after construction via Re-instatement plan 20 year post construction monitoring plan and	Adverse impact of minor significance

Phase / Project Component	Activity	Impact	Impact Significance	Mitigation Measures	Residual Significance
				interventions if unsuccessful Decommissioning EMP Biodiversity Action Plan	
	Vegetation clearance, earthworks, spoil disposal and dust deposition.	Potential loss of rare and protected plant species <i>S. chivensis</i> .	Adverse impact of minor significance	Re-instatement of habitats condition would result in no long-term impacts. 20 year post construction monitoring plan to monitor success and interventions if required. Collection of plant seed prior to construction. Re-seeding after construction and deposit of seeds / plants in national germplasm collection	Insignificant
	Pipeline excavation	Accidental entrapment of Saiga and tortoise within the pipeline excavations	Adverse impact of moderate significance	No night time working, especially during Saiga migration periods. Weekly checks of the pipeline trenches. Minimise the period of open trench works. Prompt re-instatement of trench after pipe laying. Post construction monitoring of Saiga migration. Stripping of vegetation and scraping of top-soil 1-2 weeks prior to trenching.	Adverse impact of minor significance. (Insignificant impact on the regional Saiga population)
Operation – all Project components	Operational and maintenance workers in area	Hunting of bird and mammal species by workers, including IUCN species	Adverse impact of minor to moderate significance	Hunting ban and awareness programme. Appointment of Wildlife Warden. 10 years annual monitoring of Saiga migration post-construction. <u>Biodiversity offset:</u> Consult Saiga Conservation Alliance to determine areas of financial and resource support and research into the movement of Saiga and measures to help restore Saiga population in Uzbekistan Biodiversity Action Plan	Adverse impact of minor significance (pipelines & UGCC) or Insignificant (Surgil Field)
	Operation of transmission lines	Potential electrocution / collision and breeding risk to bird species including IUCN/RDB species	Adverse impact of minor to major significance	Installation of bird deflection devices on UGCC 110kV transmission line. Adhere to Birdlife Position Statement on transmission line design	Adverse impact of minor significance (UGCC) or Insignificant (pipelines & Surgil Field)
Operation – Pipelines and UGCC	Operations of facilities in vicinity of protected area (Sudoch'ye Lake)	No direct impact on Sudoch'ye Lake. Potential increased hunting and disturbance to	Adverse impact of minor to moderate significance	Hunting ban and awareness programme. Clear demarcation/signage along boundaries of Project nearest the Sudoch'ye Lake restricting access. <u>Biodiversity offset:</u> Consult	Insignificant

Phase / Project Component	Activity	Impact	Impact Significance	Mitigation Measures	Residual Significance
	Water abstraction from Amu Darya River	birds associated with the lake. No impact from the water abstraction from the Amu Darya River.		Lake Sudoch'ye Management NGO regarding provision of financial and resource support for establishment of a Sudoch'ye Ecology Education Programme. Biodiversity Action Plan	
Operation – UGCC	Land take for UGCC site and associated infrastructure	Potential loss of habitats	Adverse impact of moderate significance	<u>Habitat compensation</u> : The UGCC wastewater pond will be designed will include the creation of reedbed habitats. In addition to the open water, the reedbeds will significantly enhance the biodiversity within the area. These areas to be managed accordingly Biodiversity Action Plan	Beneficial impact of minor significance
Water Resources and Water Quality					
Construction, Drilling and Decommissioning – all Project components	Groundwater abstraction for drilling, construction and hydrostatic testing	Less water available for human and ecological needs	Insignificant	Recycling of drilling fluid to reduce water consumption Hydrostatic testing in sections and storage and reuse of the water to reduce total water requirement by 50-60%	Insignificant
	Wastewater management / spillages	Potential contamination of water resources, including local shallow groundwater lenses	Adverse impact of minor significance to insignificant	Uz-Kor to monitor implementation of good practice environmental management during construction and decommissioning	Insignificant
	Inundation from rainfall	Flood Risk	Insignificant	Contingency plan for extreme flood events	Insignificant
Drilling – Surgil Field	Uncontrolled discharge of drilling fluids	Potential contamination of water resources	Insignificant	Drilling fluids to be pumped to drilling fluid separation plant within drilling barn for recycling	Insignificant
Construction and Decommissioning – Pipelines	Construction / de-commissioning of pipeline through Sudoch'ye overflow	Potential overflow links to marsh area and flood risk	Adverse impact of minor significance	Design to account for potential high water table and surface water flow in region of dry channel Liaison with Aral Basin Water Management for early warning of possible operation of the overflow Programming works outside main snow melt period Contingency plan for extreme flood events	Insignificant
	Discharge of hydrostatic testing water	Impacts to land	Insignificant	Discharge to UGCC wastewater treatment plant No discharge to land	Insignificant

Phase / Project Component	Activity	Impact	Impact Significance	Mitigation Measures	Residual Significance
Construction - UGCC	Construction water supply tankered from Kungrad	Traffic impacts	Adverse impact of minor significance	Construct connection to Kungrad water supply pipeline at start of construction to minimise water tankering required	Insignificant
Operation - all Project components	Operational equipment spillages	Potential contamination of water resources	Insignificant	Uz-Kor to monitor implementation of good practice environmental management	Insignificant
Operation – Surgil Field and pipelines	Produced Water Disposal	Impacts to land / groundwater	Adverse impact of moderate significance	Evaporation pond to contain and treat all wastewater Zero discharge from site	Insignificant
	Groundwater abstraction for operations	Less water available for human and ecological needs	Insignificant	Recycle water through wastewater treatment plant for use on site. Discontinuation of water transportation from Muynak to reduce water stress on local supply unit	Beneficial impact of minor significance
	Pipeline pigging and maintenance	Waste water disposal	Insignificant	Wastewaters collected and disposed by licensed waste contractor or at UGCC or Surgil CGTU WWTP	Insignificant
Operation – UGCC	Abstraction from Kungrad WSU during non-low flow period &/or implementation of committed 50m ³ /s flow release at Takhiatash	Less water available for human and ecological needs (high local water demand for irrigation purposes)	Adverse impact of minor significance	Wastewater recycling to reduce water demand by up to 35% Basin management through discussions with BVO “Amu Darya” and monitor implementation by BVO of committed 50m ³ /s flow release at Takhiatash	Insignificant
	Abstraction from Kungrad WSU during critical low flows		Adverse impact of major significance	Use of a back-up raw water supply from Tuyamuyun - Nukus WSU (abstracted from upstream of major irrigation users) Use of reserve supply storage at Kungrad WSU, raw water pond and wastewater retention pond	Adverse impact of moderate significance
	Abstraction from Kungrad WSU during winter low flows and potential reduction in flow to Muynak Lakes	No irrigation consumption but flow to Muynak Lakes need to be maintained	Adverse impact of minor significance	Basin management through discussions with BVO “Amu Darya” and monitor implementation by BVO of committed 50m ³ /s flow release at Takhiatash Use of a back-up raw water supply from Tuyamuyun - Nukus WSU which will be subject to low demand outside irrigation periods	Insignificant
	Discharge of treated wastewater to	Impacts to land / groundwater	Adverse impact of minor to	Wastewater recycling to reduce wastewater volume	Insignificant

Phase / Project Component	Activity	Impact	Impact Significance	Mitigation Measures	Residual Significance
	land at base of escarpment		moderate significance	Wastewater streams from toilet facilities disposed of using separation and soakaways All wastewater to be discharged to wastewater retention/evaporation pond Zero discharge from site	
	Inundation from rainfall	Increased runoff from areas of hardstanding	Insignificant	Appropriate design of surface drainage to manage the risk of surface ponding Emergency Plan to manage the risk during extreme storm events	Insignificant
Decommissioning – Surgil Field and Pipelines	Potential return of Aral Sea	Contaminant release to returning sea	Adverse impact of moderate significance	Detailed decommissioning plan to empty all tanks, pipelines etc, removal all structures, tanks etc. Gas wells to be properly capped. Drilling fluid basins capped with impermeable layer to prevent water ingress / contaminants migration.	Adverse impact of minor significance
		Inundation	Adverse impact of moderate significance	Continued liaison with Uzbek Government and IFAS to confirm timetable for inundation (if relevant) to allow sufficient time for planning and execution of decommissioning plan	Insignificant
Decommissioning – UGCC	De-commissioning of raw water supply infrastructure	Raw water demand removed and water resources return to baseline status	Beneficial impact of moderate significance	None	Beneficial impact of moderate significance
Materials and Waste Management					
Construction, Drilling and Decommissioning – all Project Components	Waste generation, handling and storage during construction and drilling activities. Including drilling mud cuttings and contaminated sand	Potential contamination of receiving environment e.g. ground and surface waters and land due to poor waste handling and disposal	Adverse impact of major significance	Implement site waste management procedure. Implement BAT for disposal of drilling fluids which is the development of a lined disposal basin in the vicinity of each well. Avoid sand generation in the first instance. Implement BAT for disposal of any contaminated sands which are generated	Insignificant
Operation - all Project Components	Waste generation, handling and storage during operation. Including office wastes, waste	Fugitive emissions / dust during storage / transportation Visual amenity impacts		Identify a suitable temporary storage location for each waste stream Develop Decommissioning EMP including waste management section Both the onsite and offsite	

Phase / Project Component	Activity	Impact	Impact Significance	Mitigation Measures	Residual Significance
	oils, waste chemicals, consumables.	associated with poor storage		<p>waste storage facilities will be designed to include the following:</p> <ul style="list-style-type: none"> • Separate storage areas for hazardous and non-hazardous wastes • Separate skips for each waste stream to allow segregation in order to maximise re-use and recycling opportunities • All skips to have a suitable cover • Liquid wastes/oil /chemicals to be stored in tanks or drums located in bunded areas which can hold 110% of the total storage volume • Spill kits to be available at all times 	
All Phases – all Project Components	Final Waste Disposal	<p>Use of landfill, which is a finite resource and typically scarce as well as being poorly engineered in Uzbekistan</p> <p>Increased miles transporting waste materials from the Project site.</p>	Adverse impact of minor significance	<p>Characterise each waste stream as either hazardous or non-hazardous</p> <p>Seek to minimise waste production in the first instance</p> <p>Where waste streams are unavoidable, highlight potential re-use and recycling opportunities according to current best practice</p> <p>Identify waste handling facilities in close proximity to the Project</p> <p>Review the locally available re-use/recycling facilities to ensure they can accept the waste streams. Undertake this during detailed design</p>	Insignificant
Ground Conditions					
Construction, Drilling, Decommissioning – all Project Components	Earthworks and traffic movement during well drilling, construction of roads, pipeline, UGCC, CGTU and gas gathering stations.	Soil erosion	Insignificant – Adverse impact of minor significance	<p>Construction of dedicated access roads. Permanent roads covered with hardstanding for frequently accessed areas.</p> <p>Habitat reinstatement for temporary working areas.</p>	Insignificant
	Well drilling; construction and	Leaks and spills leading to contamination of	Insignificant – Adverse impact of	Use of best practice construction methodology in line with local regulations	Insignificant

Phase / Project Component	Activity	Impact	Impact Significance	Mitigation Measures	Residual Significance
	deconstruction; use, storage and transport of hazardous materials	soils.	minor significance	and international guidelines. Implement an Emergency Response Plan and a separate Spill Contingency Plan. Implementation of a comprehensive Occupational Health and Safety Plan. Use of appropriate PPE in accordance with the IFC EHS General Guidelines.	Insignificant
		Secondary impacts to groundwater	Adverse impact of minor significance		
		Secondary impacts to human health	Adverse impact of moderate – major		
		Emergency events – large scale leaks or spills	Adverse impact of major significance		
	Drilling waste storage in surface storage pits	Soil quality	Insignificant – Adverse impact of minor significance	Evaporation lagoons and storage pits will be clay lined preventing infiltration. Solid waste will be removed periodically and disposed to the licensed Muynak landfill.	Insignificant
		Secondary impacts to groundwater	Adverse impact of minor significance		
		Secondary impacts to human health	Adverse impact of moderate – major		
	Waste disposal	Contamination of soils, impacts to soil quality	Insignificant-Adverse impact of minor significance	Implementation of a site specific waste management plan.	Insignificant
Operation - all Project Components	Use, transport and storage of hazardous materials	Leaks and spills leading to soil contamination	Insignificant – Adverse impact of minor significance	Use of best practice storage and handling methodology in line with local regulations and international guidelines. Implement an Emergency Response Plan and a separate Spill Contingency Plan	Insignificant
		Secondary impacts to groundwater	Adverse impact of minor significance		
		Secondary implications for human health	Adverse impact of moderate – major		
	Waste disposal	Contamination of soils, impacts to soil quality	Insignificant-Adverse impact of minor significance	Implementation of a site specific waste management plan.	Insignificant
Impacts to groundwater			Adverse impact of		

Phase / Project Component	Activity	Impact	Impact Significance	Mitigation Measures	Residual Significance
			minor significance		
	Vehicle movements	Soil erosion	Insignificant-Adverse impact of minor significance	Use dedicated roads. For the pipeline - limited vehicle movements due to the infrequent nature of accessing the area	Insignificant
	Damage to pipeline due to corrosion or landslips	Large scale leaks and spills leading to secondary impacts to groundwater	Adverse impact of major significance	Protective coating will minimise corrosion. Implement an Emergency Response Plan and a separate Spill Contingency Plan. Safety valves will be installed along the condensate pipeline length at 10km intervals to the volume lost and resultant contamination should there be any breaches of the pipeline structure.	Insignificant
Construction and Operation - Pipelines	Urga crossing	Erosion and landslide risks	Adverse impact of minor significance	Install pipeline to sufficient depth in order to allow adequate backfilling to create a stabilised ground surface. Pipeline installation technique to take landslide risk into account. Monitor pipeline route on monthly basis to check for damage and/or exposure caused by landslides.	Insignificant
Construction, Drilling, Operation and Decommissioning – Surgil Field and associated pipeline only	All activities	Mobilisation of dust contaminated with DDT with secondary implications for human health.	Adverse impact of moderate significance	Implementation of a comprehensive Occupational Health and Safety Plan. Undertake human health Detailed Quantitative Risk Assessment to determine site specific risk factors for key pathways to facilitate the specification of appropriate Personal Protective Equipment, in accordance with the IFC EHS General Guidelines, required for site workers. Construction workers to wear dust masks.	Insignificant
Noise and Vibration					
Construction, Drilling, Decommissioning – all Project Components	Construction, Drilling and decommissioning activities, indulging excavation, traffic piling, plant installation etc.	Noise impacts to workers and/or sensitive receptors	Ranging from insignificant to adverse impact of minor significance depending on activity	Adhere to good practice guideline BS 5228: Code of Practice for Noise and Vibration Control Implement various embedded mitigation measures defined in ESIA during activities	Ranging from insignificant to adverse impact of minor significance depending on activity

Phase / Project Component	Activity	Impact	Impact Significance	Mitigation Measures	Residual Significance
Operations – all Project Components	Operations and maintenance activities			Particularly noisy plant items to use silencers and attenuators, where necessary	
Traffic and Transportation					
Construction, Drilling, Decommissioning – all Project Components	Increased vehicle movements on public roads, in particular the R-173 and A-830 Increased abnormal loads from Kungrad rail station to the Surgil Field and UGCC Transportation of equipment and materials from railway stations to sites.	Exceedance of road network capacity resulting in disruption to existing users	Adverse impact of minor significance	Develop Construction Traffic Management Plan (CTMP) in consultation with relevant local transport authority CTMP to consider measures to reduce wear and tear.	Adverse impact of minor significance
		Delays to users as result of abnormal loads	Insignificant	Voluntary agreement with the relevant highways authority to reimburse the cost of repairs required to the public highway network as a result of the project.	Insignificant
		Wear and tear on R-173 and A-830	Adverse impact of moderate to minor significance	Undertake pre and post-construction surveys of the affected stretches of public highway; ideally involving enhancement of the existing road network following any remedial works. CTMP to include measures to reduce the risk to road users and residents and will consider the option of bypassing particularly sensitive communities. Consultation with affected communities so that CTMP takes into account local circumstance.	Adverse impact of minor significance or Beneficial impact of minor significance - due to potential enhancement
		Reduced safety of road users on the R-173 and A-830 and residents along these road, and workers camps. Increase risk of road accidents.	Adverse impact of moderate to minor significance		Adverse impact of minor significance
		Import and export of equipment by rail	Impacts scheduling for rails network	Adverse impact of minor significance	Consultation with the rail network operator to accurately assess the potential level of disruption to services. Develop appropriate rail management scheme detailing suitable delivery timings and loading / unloading protocols.
Operations – all Project Components	Increased vehicle movements on public roads, in particular the R-173 and A-830 Operation of new rail spur	Disruption and delay to road users and increased safety risks	Insignificant	N/A	Insignificant
		Reduced safety of residents of	Adverse impact of	Consultation with local community to establish more	Adverse impact of

Phase / Project Component	Activity	Impact	Impact Significance	Mitigation Measures	Residual Significance
	for UGCC adjacent to Akchalak Including transport of some hazardous materials	Akchalak, particularly children, in vicinity of the new rail	moderate significance	precisely the nature of risk and identify suitable mitigation strategies. Examine options to include as a minimum, securely fencing off the railway from the community and re-routing the line further from the settlement. Rail transport safety / hazard management plan	minor significance
	Decreased HGV movements on R-173 due to less potable water and condensate transportation	Reduced use of road network limiting impacts to existing users from safety risks and delays.	Beneficial impact of minor significance	N/A	Beneficial impact of minor significance
Landscape and Visual					
Construction, Drilling, Decommissioning – all Project Components	Construction, drilling, decommissioning activities, access roads, transportation, stockpiling of materials and storage	Visual impact to local people e.g. farmers / herders recreational users and settlements. Negative effect on landscape character (soil stripping, vegetation loss, light pollution) Reduction in tranquillity.	Varying impact from Insignificant to Adverse impact of moderate significance, depending on location and level of existing infrastructure in area	Restriction of vehicle movements to agreed transport corridors Removal of construction waste materials from the site Creation of linear banks to even profile along buried pipeline route Design of site lighting to minimise light pollution.	Varying impact from Insignificant to Adverse impact of minor significance, depending on location and level of existing infrastructure in area
Operations – all Project Components	New built structures and transmission lines, additional traffic, disposal of surplus spoil.	Light pollution. Negative effect on landscape character and views within 10km of the sites. Reduced damage to vegetation and soil surface through use of new roads will have a positive effect on views	Adverse impact of minor significance	Restriction of vehicle movements to agreed transport corridors Design of site lighting to minimise light pollution	Adverse impact of minor significance

Phase / Project Component	Activity	Impact	Impact Significance	Mitigation Measures	Residual Significance
Decommissioning – all Project Components	De-commissioning and removal of facilities and equipment. Above ground plant will be drained, made safe and removed. Gas wells capped off at ground level.	Increased activity in area during activities but removal of structures will eventually restore the area to a more natural state. Raised earth banks along pipeline route will remain but will be eroded by weather	Adverse impact of minor significance	Restriction of vehicle movements to agreed transport corridors via dedicated decommissioning strategy Removal of construction waste materials from the site Levelling of disturbed ground Design of site lighting to minimise light pollution.	Adverse impact of minor significance
Air Quality					
Construction, Drilling, Decommissioning – all Project Components	Soil excavation and handling Materials transport Foundations and construction	Dust generation Exposure to contaminated dust from localised areas of the site.	Adverse impact of minor to moderate significance	Dust mitigation measures in line with international best practice and IFC EHS guidelines, e.g. dust suppression, covered stockpiles and loads etc. Undertake human health Detailed Quantitative Risk Assessment to determine site specific risk factors associated with dust from potentially contaminated soils PPE – Dust masks as a minimum	Insignificant
	Mobile equipment and vehicles	Combustion and fugitive emissions	Insignificant	Emission mitigation measures in line with international best practice, e.g. for mobile sources No open burning of solid waste	Insignificant
Operations – Surgil Field and UGCC	UGCC, CGTU and well operation	Local air quality effects e.g. associated with NO ₂ emissions	Insignificant	Assumes embedded mitigations Monitoring of NO ₂ emissions before plant commissioning and during operation For UGCC install appropriate stack heights in line with international practice and dry-low NO _x burners for gas turbines	Insignificant
		Operational fugitive emissions (VOCs)	Insignificant	Industry best practice measures and design to avoid fugitive emissions, in line with IFC EHS guidelines, e.g. fugitive monitoring, maintain stable tank pressures, appropriate tank design, use of recovery systems etc. where appropriate.	Insignificant

Phase / Project Component	Activity	Impact	Impact Significance	Mitigation Measures	Residual Significance
				Monitoring of VOC emissions before plant commissioning and during operation	
Greenhouse Gas Emissions					
Construction, Drilling, Decommissioning – all Project Components	Power generation from mobile sources	Increased GHG Emissions	N/A	Industry best practice measures and design to minimise combustion emissions	
Operations – all Project Components	CGTU Flare operation	GHG emissions via venting and combustion	N/A	Construction of new flare to prevent direct venting of gas. Reduced flaring via re-powering of CGTU to utilise previously flared waste gas. Monitoring and metering of gas to ensure flare operates efficiently.	
	UGCC operation	GHG combustion and fugitive emissions	N/A	Use of efficient combined cycle gas turbines to provide heat and power. Optimisation of all combustion relating emissions across the site to ensure high energy efficiency. Online VOC monitoring to identify fugitive emissions and allow prompt repair. Minimal use of flare in normal operation. Management and inventory of high GHG potential pollutants such as SF ₆ (used as an electrical insulator) to minimise emissions losses.	
Cultural Heritage and Archaeology					
Construction, Drilling, Decommissioning – Surgil Field and Pipelines	Excavation works	Disturbance to unknown archaeological features.	Insignificant to Adverse impact of minor significance	Use of an archaeological watching brief during all earthworks and excavations. Adoption of best practice 'chance finds' procedure. Liaison with the Institute of Archaeology in Nukus.	Insignificant
Construction, Drilling, Decommissioning – UGCC and associated infrastructure			Adverse impact of moderate significance		Adverse impact of minor significance

3.3 Cumulative Impacts with Other Projects

Cumulative impacts are those that may result from the combined effects of several activities, either existing or planned, in a project's zone of influence. While a single activity may itself result in an insignificant impact, it may, when combined with other impacts (significant or insignificant) in the same geographical area and occurring at the same time, result in a cumulative impact that is significant.

The Project ESIA process included, where relevant, consideration of the cumulative impact of the Surgil Project with other present and planned developments in the zone of influence. The developments included in the cumulative impact assessment are:

- Akchalak Gas Compressor Station, located close to the UGCC site which has been considered for potential cumulative impacts associated with the socio-economics of the local area, water resource use and quality, noise and vibration effects, landscape and visual amenity and local air quality; and
- Kungrad Soda Ash Plant, located approximately 8 km south-east of the UGCC site, which has been considered for potential cumulative impacts associated with water resource use, landscape and visual impacts and local air quality.

On the Ustyurt Plateau the Urga gas field is being developed with associated gas field development such as the Akchalak gas field and is being developed by Petronas (under concession from UNG). The closest development activity (Akchalak field) from the Urga project is approximately 25 km from the nearest Project component and therefore will not be subject to any cumulative impacts and has not been considered further.

In the Aral Sea Basin the East and North Berdakh gas fields, developed and operated by UNG, are located near to the village of Uchsay to the south east of the Surgil field. The Berdakh CGTU is 24 km from the Surgil CGTU and at least 16 km from the nearest gas well being developed as part of the Surgil Project. Again, this distance between the Surgil Project and the Berdakh gas fields will not result in any cumulative impacts. Consideration was given to indirect cumulative impacts such as traffic impacts on roads from Muynak to Uchsay and to the Surgil Field but the capacity of the road and number of vehicle movements was not assessed to be significant and thereby did not represent a potentially significant cumulative impact that needed to be addressed.

3.4 How Uz-Kor will manage environmental and social impacts?

Uz-Kor has developed an Environmental and Social Management Plan (ESMP) that draws upon the management and mitigation measures which have been defined within the ESIA. The ESMP is presented as Volume IV of the ESIA documentation. The primary objective of an ESMP is to safeguard the environment, site staff and the local population from site activity that may cause harm or nuisance. The management plan, which also covers monitoring, is the basis of the environmental and social protection measures to be implemented by Uz-Kor and its contractors.

In addition to the ESMP, a number of complimentary framework plans, policies and procedures have been developed including the following:

- Construction Environmental Management Plan;
- Public Consultation and Disclosure Plan;
- Recruitment plan;
- Retrenchment plan;
- Labour grievance mechanism;
- Community grievance mechanism;
- Community Investment Programme Framework;
- Site waste management plan;
- Traffic management plan;
- Temporary worker accommodation management plan;
- Biodiversity Action Plan;
- Chance finds procedure; and
- Air quality monitoring programme.

Responsibilities for implementation are outlined in the ESMP and fall to either Uz-Kor or the various contractors.

The implementation of the ESMP ensures EHS performance is in accordance with international standards (including the relevant ADB and IFC EHS standards and guidelines) and best practice.

Moving into the operational phase, Uz-Kor will develop an environmental and social management system (ESMS), to cover all Project components, in line with international standards such as ISO 14001. This will ensure best practices with regards to environmental and social management are imbedded into the operational philosophy of the Project.