



868 MURRAY ROAD DOTHAN, AL 36303

**"REDIFLEX"  
TWO-PIECE STEEL FRAME SYSTEM  
UTILIZING A  
MASONITE DOUBLE OPAQUE STEEL DOOR  
"IMPACT"**

GENERAL NOTES

1. This product has been evaluated and is in compliance with the 2010 Florida Building Code (FBC) structural requirements including the "High Velocity Hurricane Zone" (HVHZ).
2. Product anchors shall be as listed and spaced as shown on details. Anchor embedment to base material shall be beyond wall dressing or stucco.
3. When used in the "HVHZ" this product complies with Section 1626 of the Florida Building Code and does not require an impact resistant covering.
4. When used in areas outside of the "HVHZ" requiring wind borne debris protection this product complies with Section 1609.1.2 of the FBC and does not require an impact resistant covering. This product meets missile level "D" and includes Wind Zone 4 as defined in ASTM E1996 and section 1609.1.2.4 of the FBC.
5. For 2x stud framing construction, anchoring of these units shall be the same as that shown for 2x buck masonry construction.
6. Site conditions that deviate from the details of this drawing require further engineering analysis by a licensed engineer or registered architect.
7. Outswing configurations using item #72 meet water infiltration requirements for "HVHZ".
8. Configurations using item #70 and #71 do not meet the water infiltration requirements for the "HVHZ" and shall be installed only in non-habitable areas or at habitable locations protected by an overhang or canopy such that the angle between the edge of canopy or overhang to sill is less than 45 degrees.
9. All steel shall be protected as specified in Section 2220 of the FBC. In addition, steel in contact with aluminum shall be protected as specified in Section 2003.8.4 of the FBC.

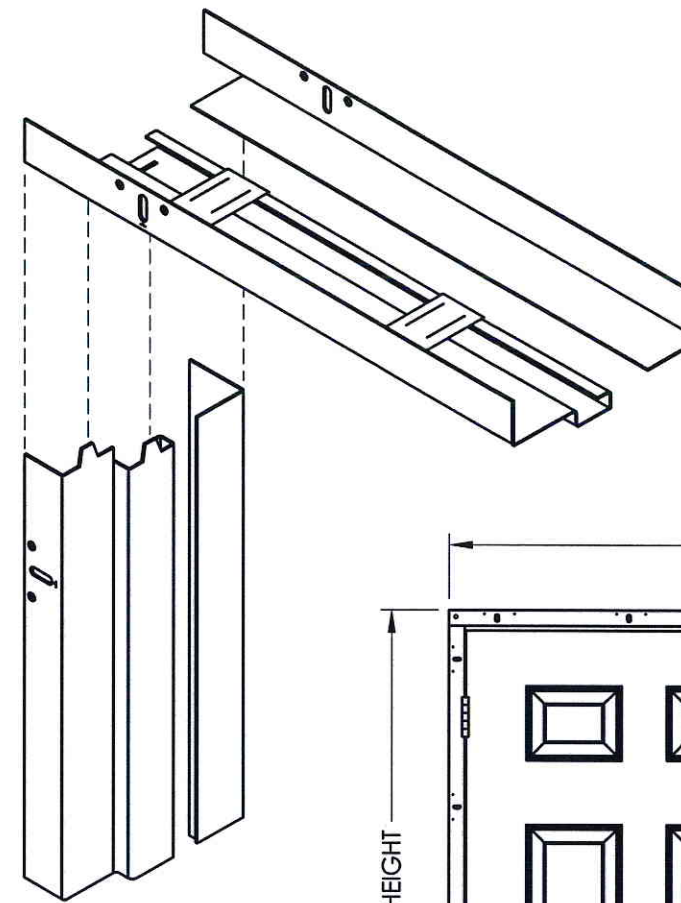

**REDIFLEX TWO-PIECE**

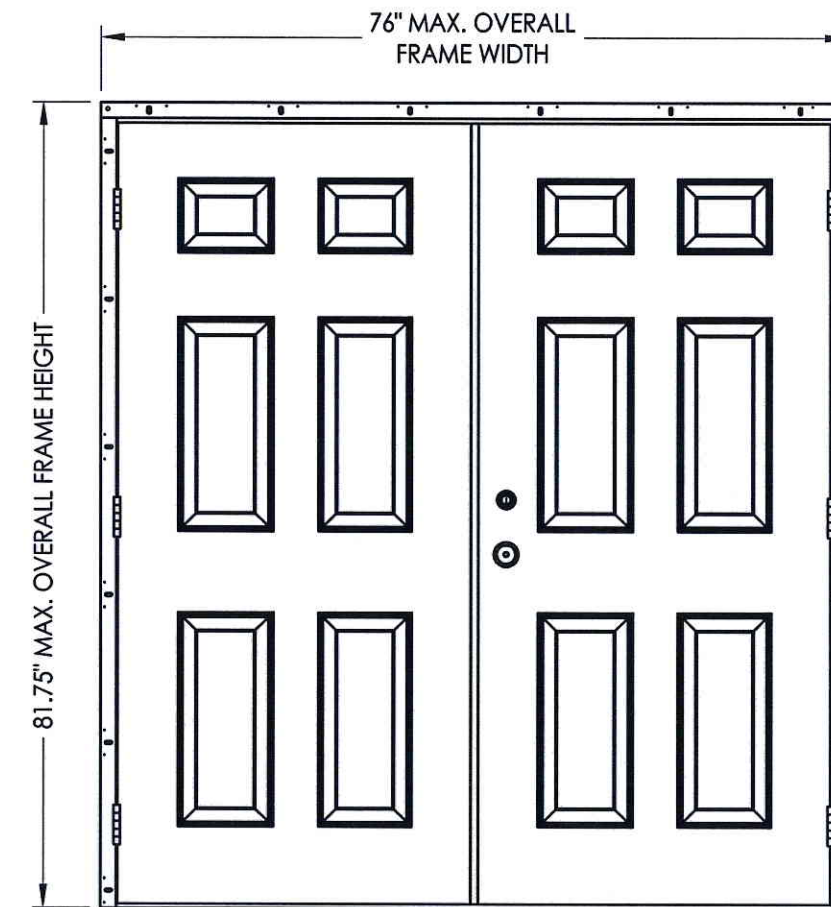

**OUTSWING**

TABLE OF CONTENTS	
SHEET #	DESCRIPTION
1	Typical elevation, design pressures & general notes
2	Steel frame cross sections & details
3	Door panel details
4	Horizontal & vertical cross sections
5	Horizontal & vertical cross sections
6	Buck & frame anchoring - masonry 2x buck
7	Buck & frame anchoring - steel/2x stud
8	Astragal details
9	Bill of materials and components

OVERALL FRAME DIMENSION	THRESHOLD TYPE	DESIGN PRESSURE (PSF) NON-HVHZ		DESIGN PRESSURE (PSF) HVHZ	
		POSITIVE	NEGATIVE	POSITIVE	NEGATIVE
76.0" X 81.75"	ADA	+ 55.0	- 55.0	+ 55.0*	- 55.0*
76.0" X 81.75"	STANDARD BUMP	+ 55.0	- 55.0	+ 50.0	- 50.0
76.0" X 81.75"	HIGH DAM	+ 55.0	- 55.0	+ 55.0	- 55.0

\*See General Note #8

Documents Prepared By:

**RW** BUILDING CONSULTANTS, INC.  
P.O. Box 250 Valrico FL 33595  
Phone No.: 813.659.9197  
Florida Board of Professional Engineers  
Certificate Of Authorization No. 9813  
*LFS 6.2.13*  
Lyndon F. Schmidt, P.E. No. 43409

PRODUCT:  
DUNBARTON REDIFLEX  
TWO-PIECE STEEL FRAME

PART OR ASSEMBLY:  
TYPICAL ELEVATION, DESIGN  
PRESSURES & GENERAL NOTES

NO.	DATE	BY	REVISIONS

DATE: 6/3/13  
SCALE: N.T.S.  
DWG. BY: JK  
CHK. BY: LFS  
DRAWING NO.: FL-15341.7  
SHEET 1 OF 9

R:\A - Projects\Project Folders\Proj 1601 - 1700\PF 1650\DWBC Drawings\FL-15341.1-8.dwg, FL-15341.7

© 2012 R.W. BUILDING CONSULTANTS INC.

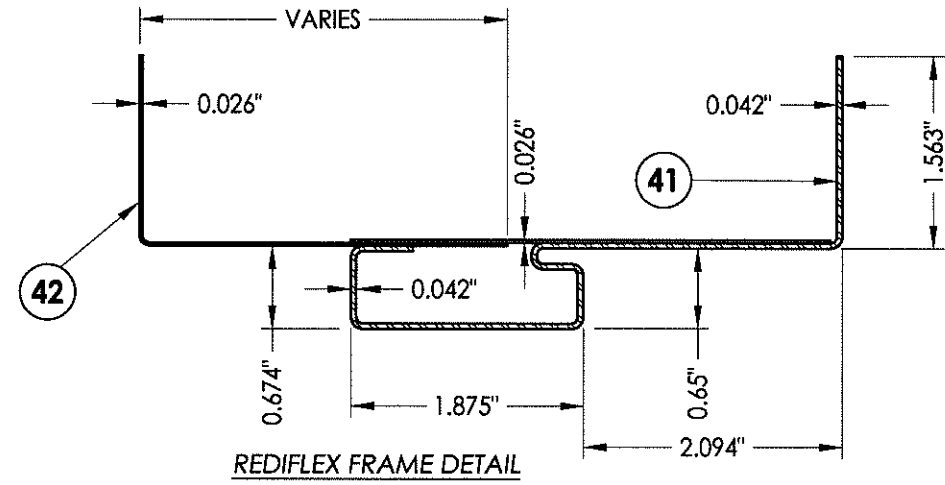
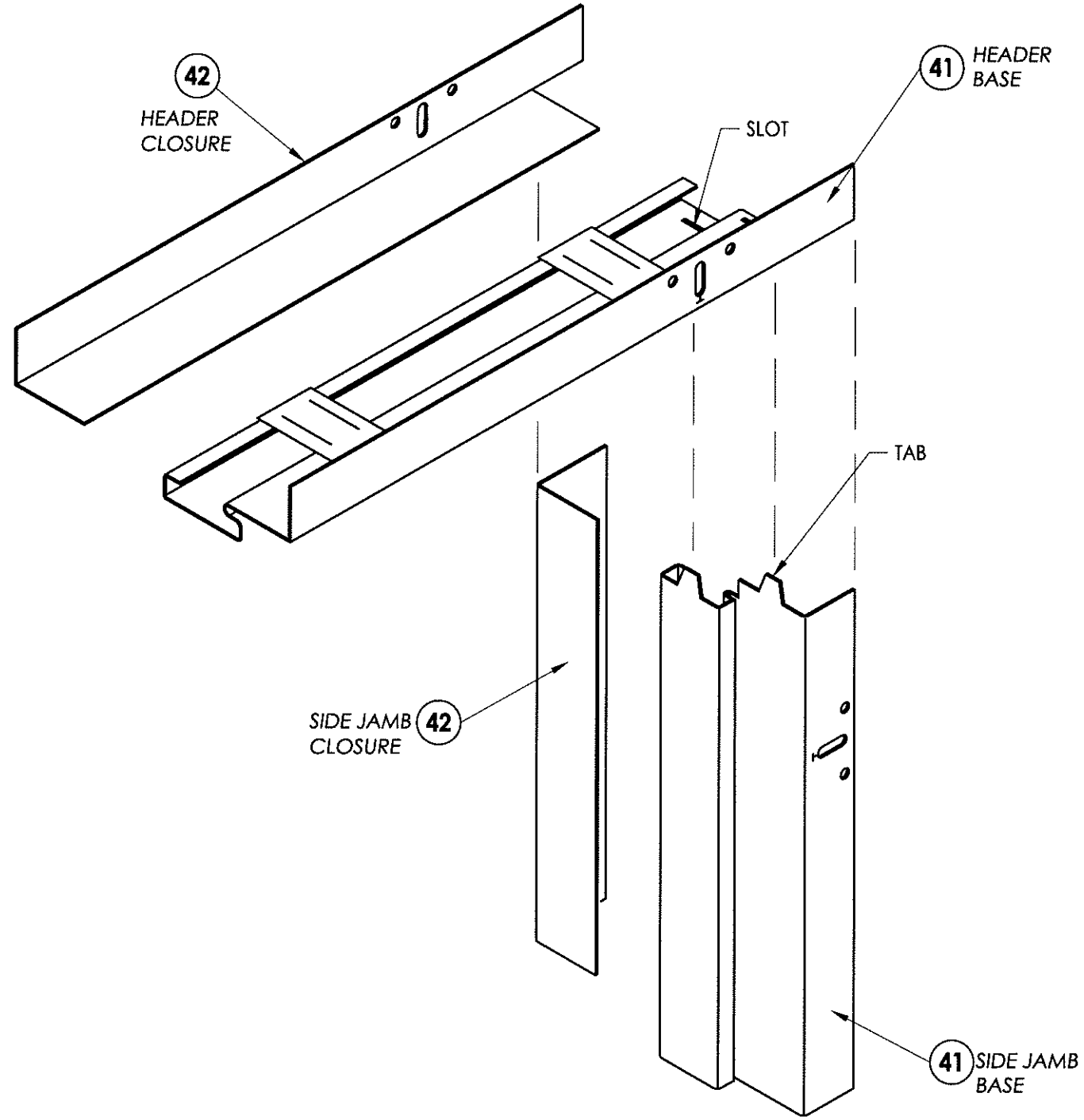

**NOTES:**

1. HEADER AND SIDE BASE JAMB (41) MINIMUM 18 GA. GALV. STEEL.
2. HEADER AND SIDE CLOSURE JAMB (42) MINIMUM 22 GA. GALV. STEEL.
3. FRAME SHOWN WITHOUT OPTIONAL STEEL TRIM CASING.
4. NON-KERF FRAMES DO NOT MEET AIR AND WATER CRITERIA.

Documents Prepared By:  
**RW** BUILDING CONSULTANTS, INC.  
 P.O. Box 230 Valrico FL 33595  
 Phone No.: 813.659.9197  
 Florida Board of Professional Engineers  
 Certificate Of Authorization No. 9813  
*LFS 6.12.13*  
 Lyndon F. Schmidt, P.E. No. 43409

PRODUCT:  
 DUNBARTON REDIFLEX  
 TWO-PIECE STEEL FRAME  
 PART OR ASSEMBLY:  
 STEEL FRAME CROSS SECTION  
 & DETAILS

NO.	DATE	BY	REVISIONS

DATE: 6/3/13  
 SCALE: N.T.S.  
 DWG. BY: JK  
 CHK. BY: LFS  
 DRAWING NO.:  
 FL-15341.7  
 SHEET 2 OF 9

HARDWARE CHART		
MANUFACTURER	MODEL	
KWIKSET	LEVER:	200DL
	DEADBOLT:	Signature Series 980
SCHLAGE	LOCK:	F51
	DEADBOLT:	B60N

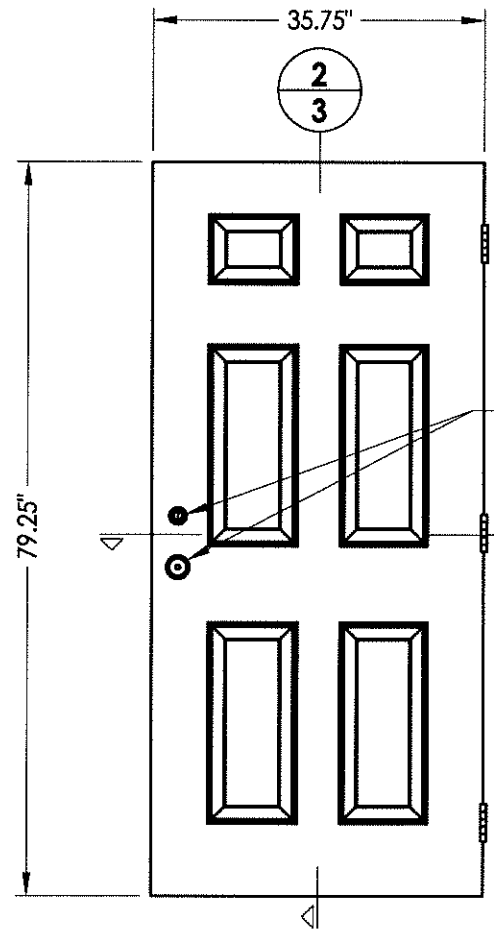

SEE HARDWARE CHART

50 DOOR PANEL  
Masonite

STEEL SKIN: 0.020" MIN. THICK (Fy = 33,000 PSI MIN.)  
FOAM CORE: POLYURETHANE (2.0 PCF DENSITY, BASF)

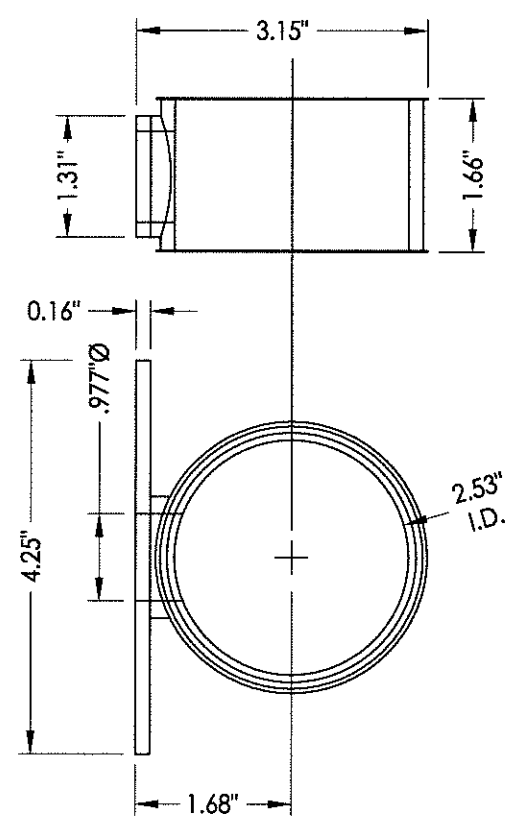

1A LOCK RING

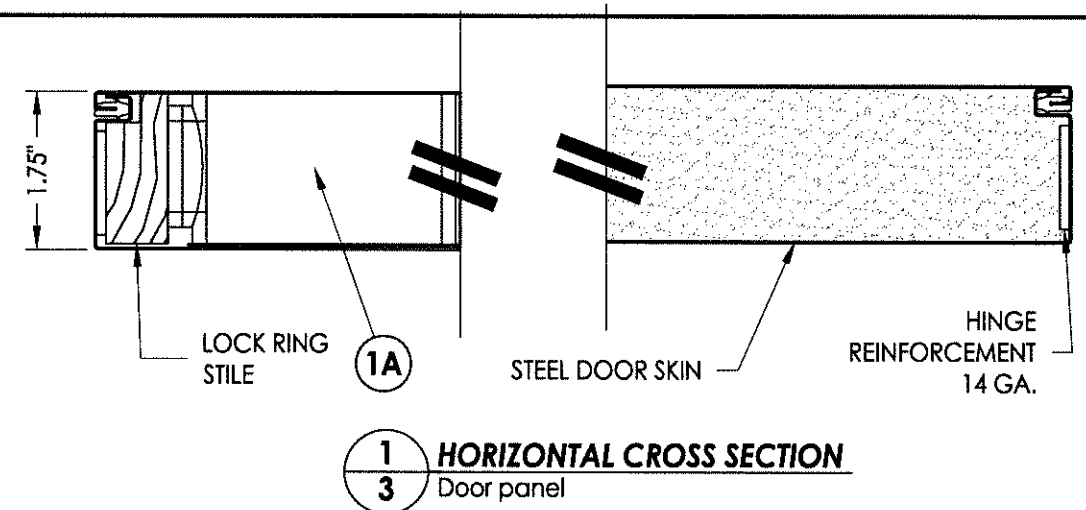

1 HORIZONTAL CROSS SECTION  
3 Door panel

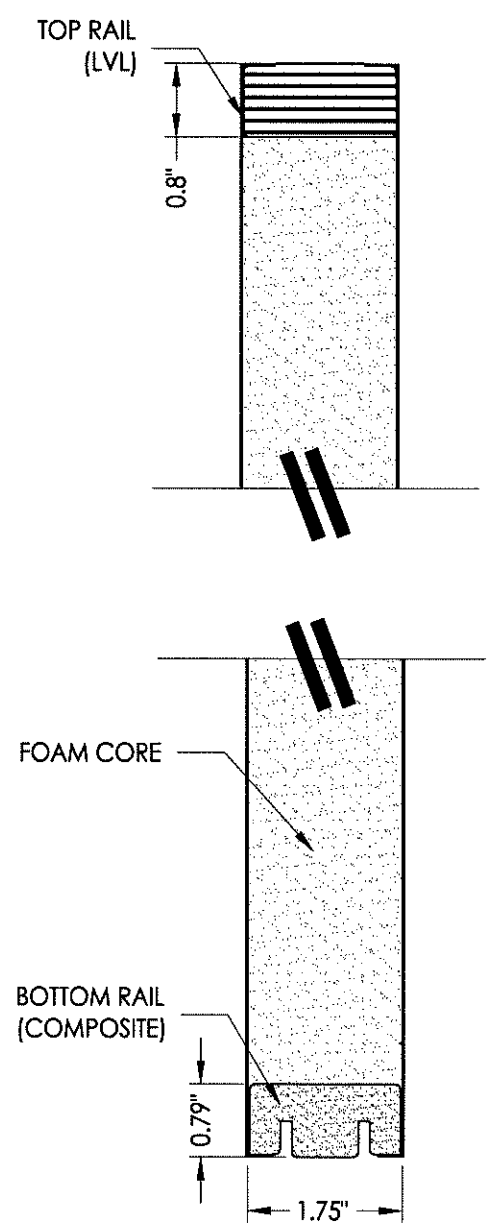
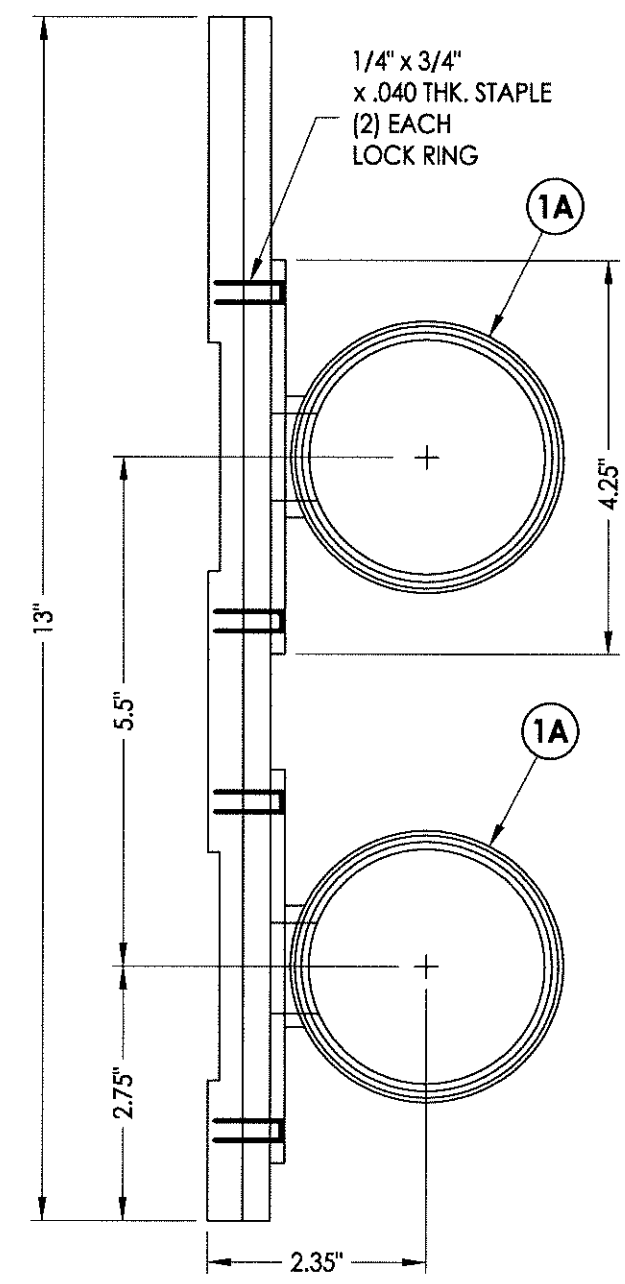

2 VERTICAL CROSS SECTION  
3 Door panel

Documents Prepared By:  
**RW** BUILDING CONSULTANTS, INC.  
P.O. Box 230 Valrico FL 33595  
Phone No.: 813.659.9197  
Florida Board of Professional Engineers  
Certificate of Authorization No. 9813  
*LFS* 6.12.13  
Lyndon F. Schmidt, P.E. No. 43409

PRODUCT:  
DUNBARTON REDIFLEX  
TWO-PIECE STEEL FRAME  
PART OR ASSEMBLY:  
DOOR PANEL DETAILS

NO.	DATE	BY

DATE: 6/3/13  
SCALE: N.T.S.  
DWG. BY: JK  
CHK. BY: LFS  
DRAWING NO.: FL-15341.7  
SHEET 3 OF 9

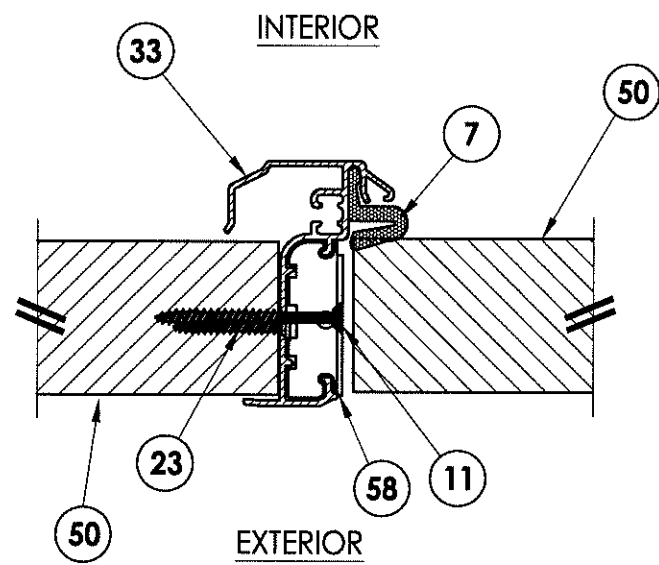
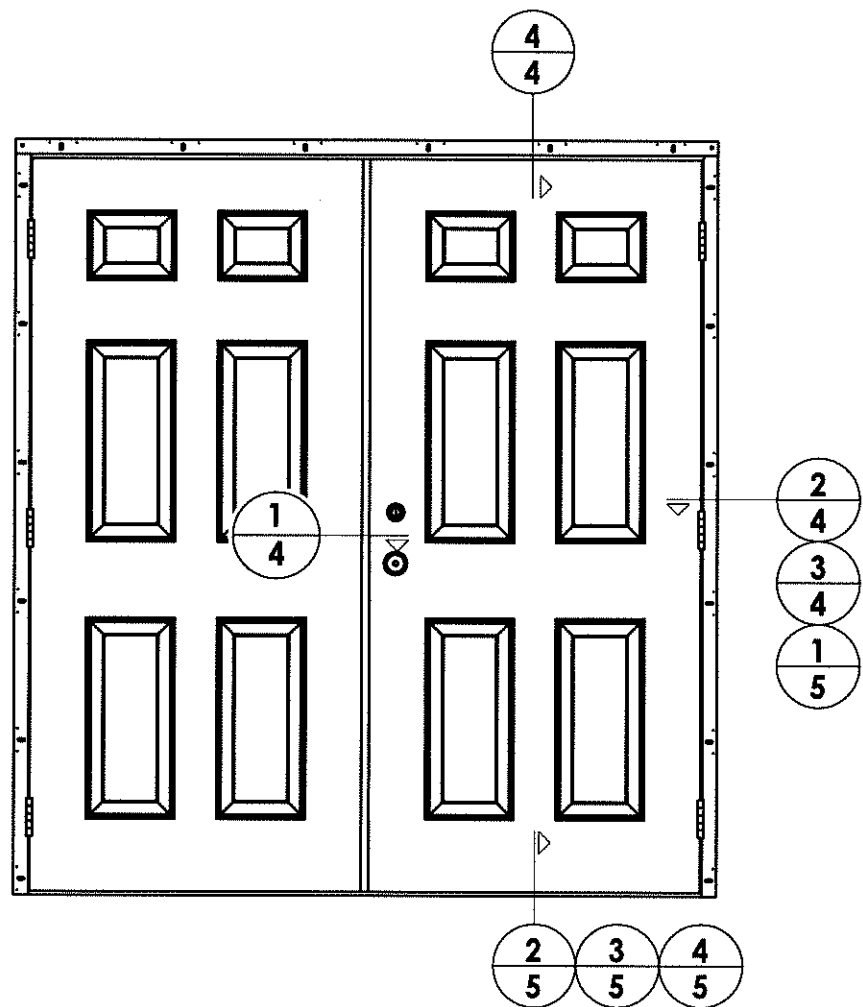

**1**  
**4** HORIZONTAL CROSS SECTION

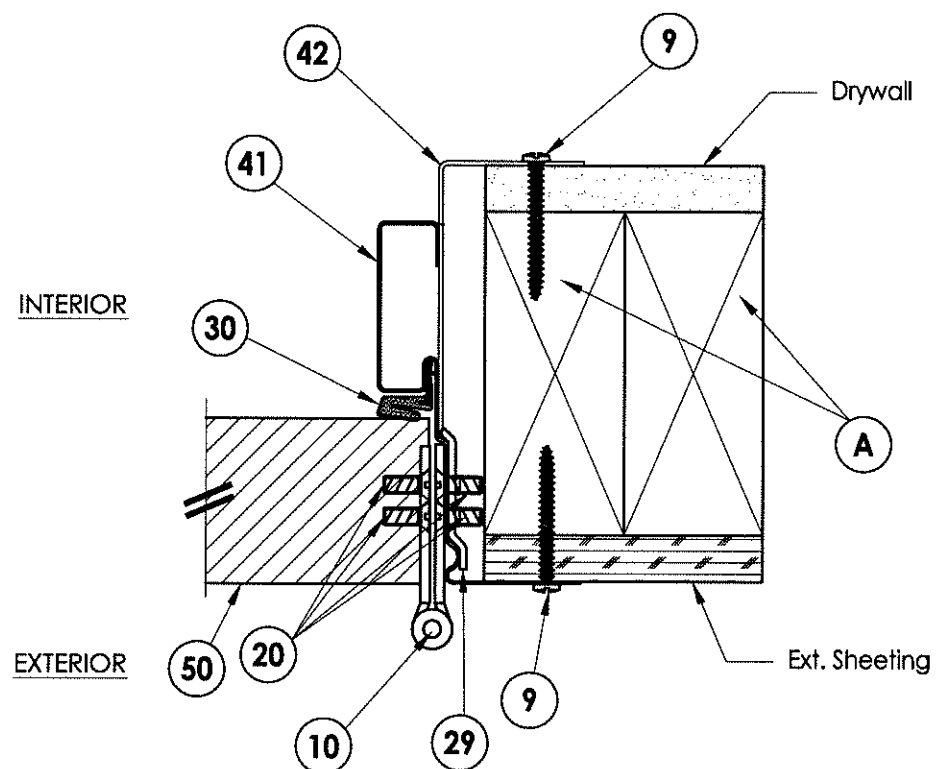

**2**  
**4** HORIZONTAL CROSS SECTION  
Optional 2X Stud Construction

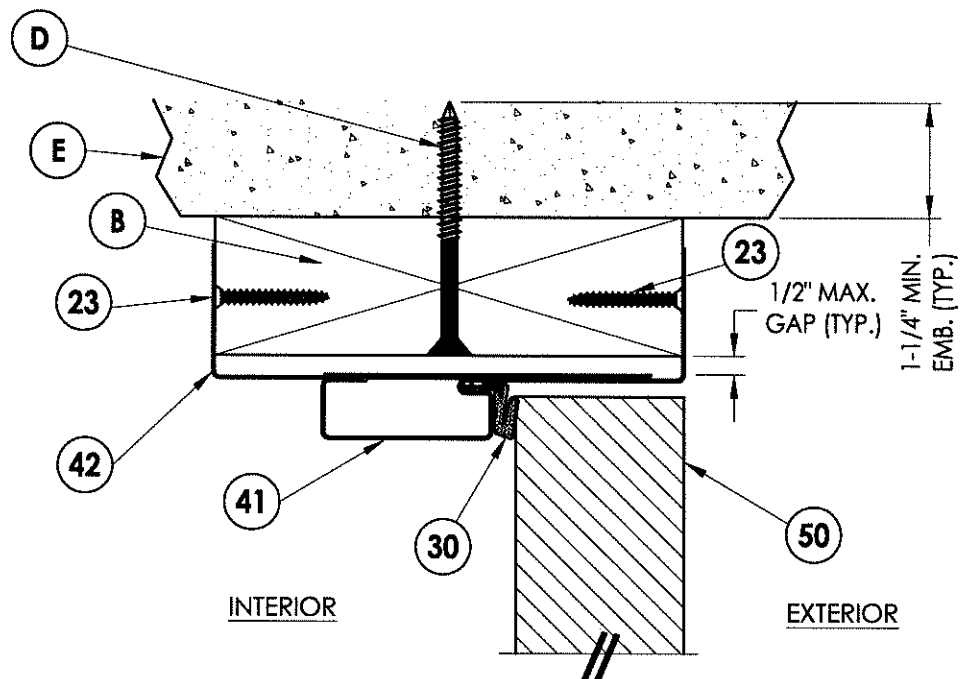

**4**  
**4** VERTICAL CROSS SECTION  
2X wood buck

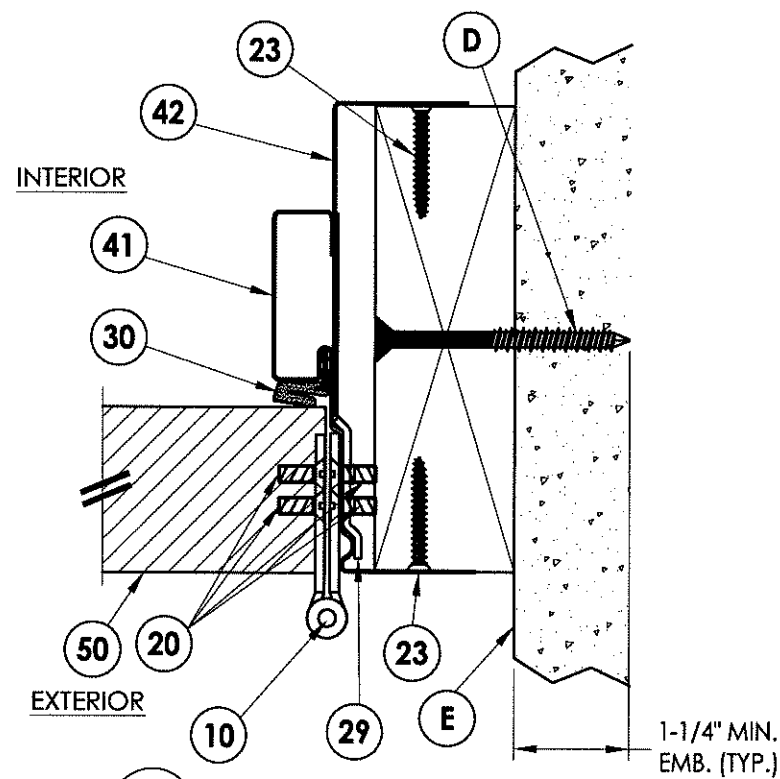

**3**  
**4** HORIZONTAL CROSS SECTION  
2X wood buck

NO.	DATE	BY

DATE: 6/3/13

SCALE: N.T.S.

DWG. BY: JK

CHK. BY: LFS

DRAWING NO.:

FL-15341.7

SHEET 4 OF 9

PRODUCT:  
DUNBARTON REDIFLEX  
TWO-PIECE STEEL FRAME

PART OR ASSEMBLY:  
HORIZONTAL & VERTICAL  
CROSS SECTIONS

Documents Prepared By:

**RW** BUILDING CONSULTANTS, INC.  
P.O. Box 230 Valrico FL, 33595  
Phone No.: 813.659.9197  
Florida Board of Professional Engineers  
Certificate of Authorization No. 9813  
6/20/13  
Lyndon F. Schmidt, P.E. No. 43409

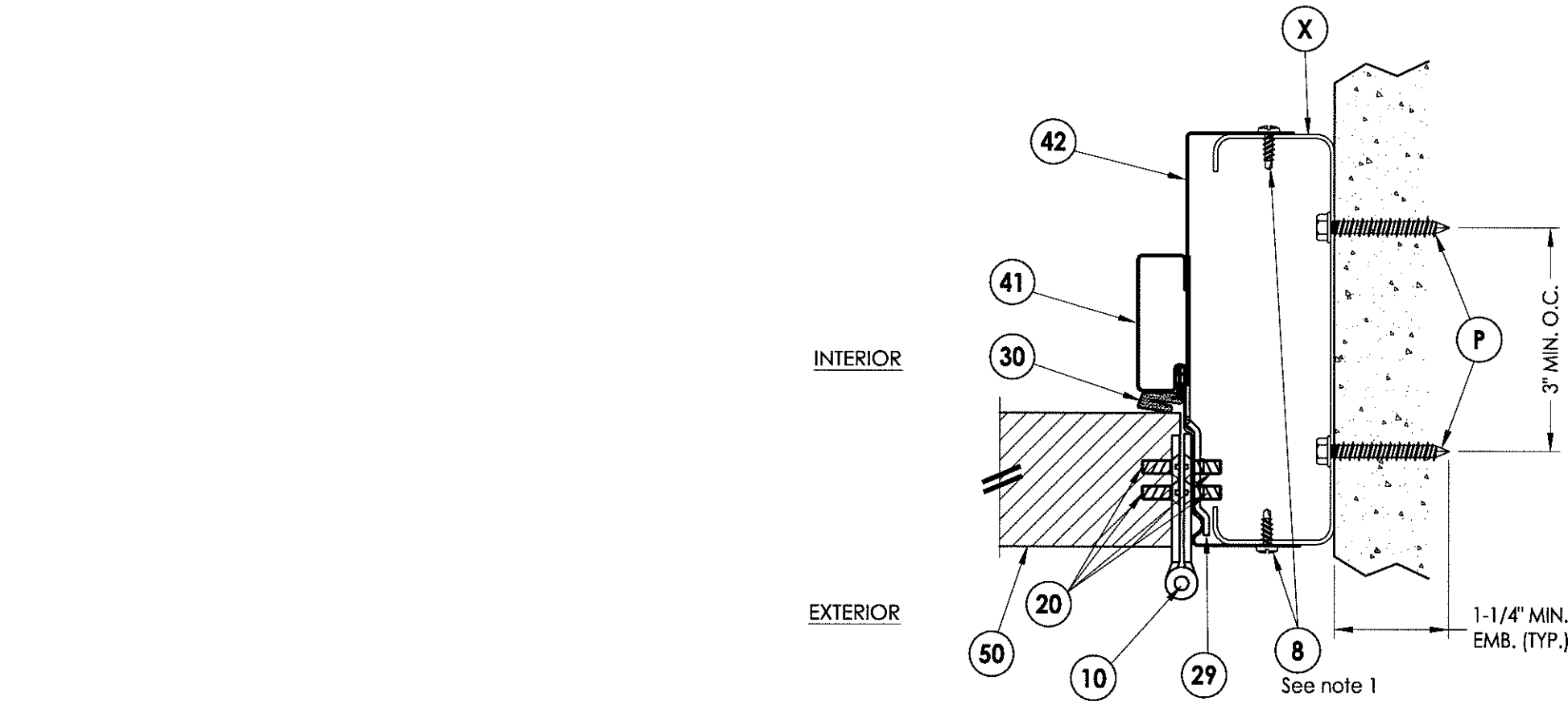

**1 HORIZONTAL CROSS SECTION**  
**5** Optional steel stud construction

Note:  
 1. A minimum of three threads must protrude completely though the supporting steel stud.

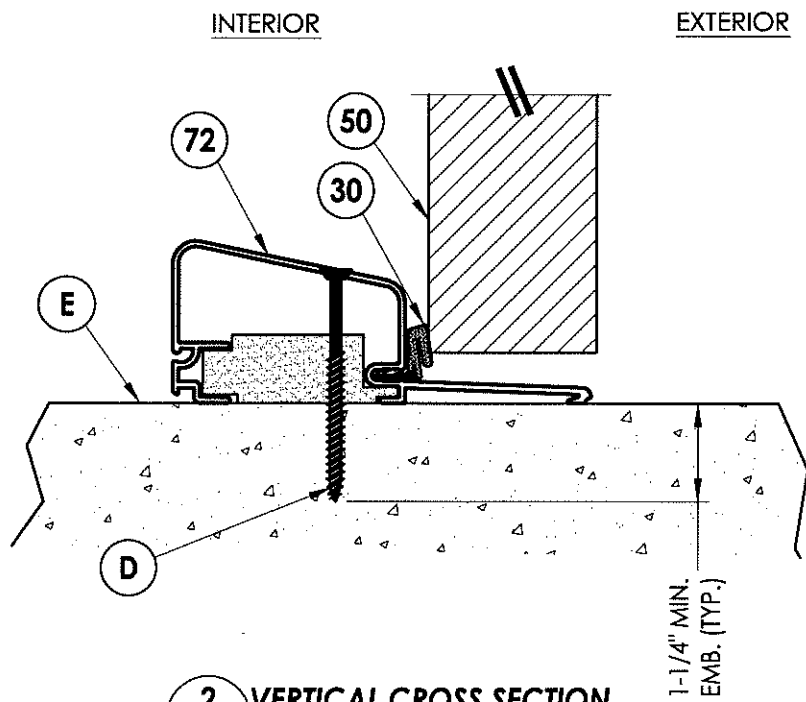

**2 VERTICAL CROSS SECTION**  
**5** Shown w/ High Dam Threshold

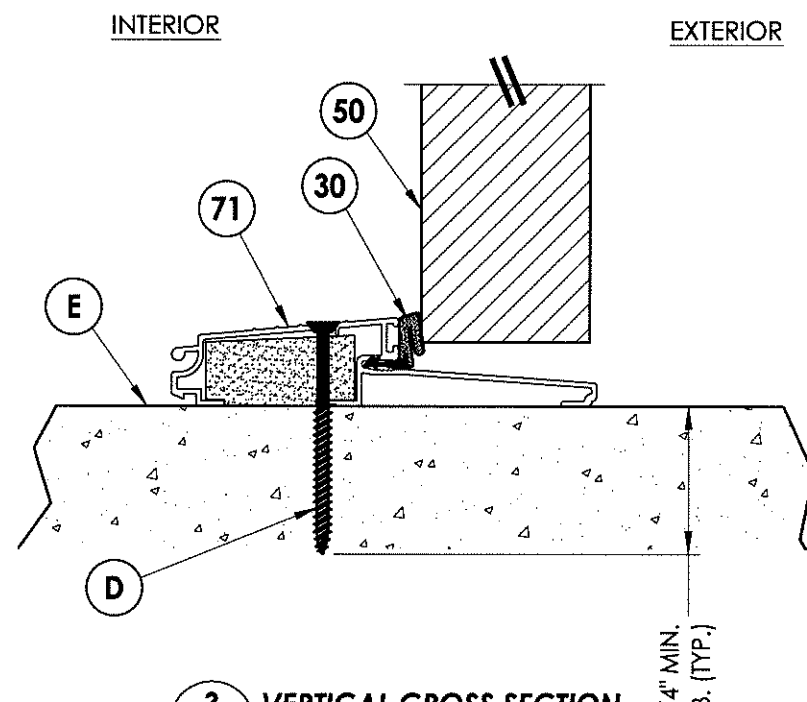

**3 VERTICAL CROSS SECTION**  
**5** Shown w/ Outswing Threshold

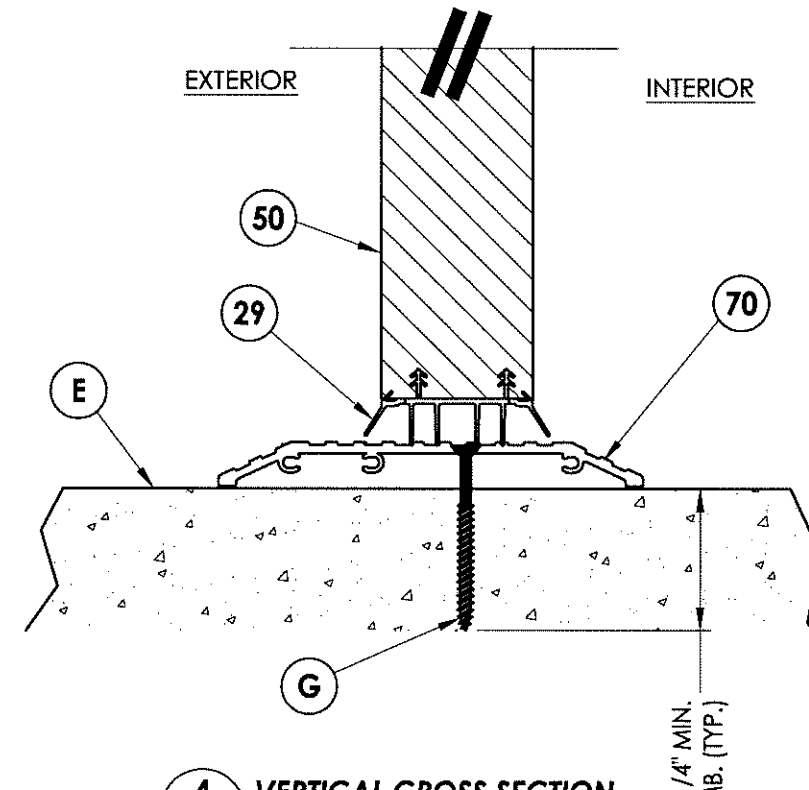

**4 VERTICAL CROSS SECTION**  
**5** Shown w/ ADA Threshold

PRODUCT:  
 DUNBARTON REDIFLEX  
 TWO-PIECE STEEL FRAME

PART OR ASSEMBLY:  
 HORIZONTAL & VERTICAL  
 CROSS SECTIONS

NO.	DATE	BY

DATE: 6/3/13  
 SCALE: N.T.S.  
 DWG. BY: JK  
 CHK. BY: LFS  
 DRAWING NO.: FL-15341.7  
 SHEET 5 OF 9

Documents Prepared By:  
**RW** BUILDING CONSULTANTS, INC.  
 P.O. Box 230 Vairico FL, 33595  
 Phone No.: 813.659.9197  
 Florida Board of Professional Engineers  
 Certificate Of Authorization No. 9813  
*LFS* 6.12.13  
 Lyndon F. Schmidt, P.E. No. 43409

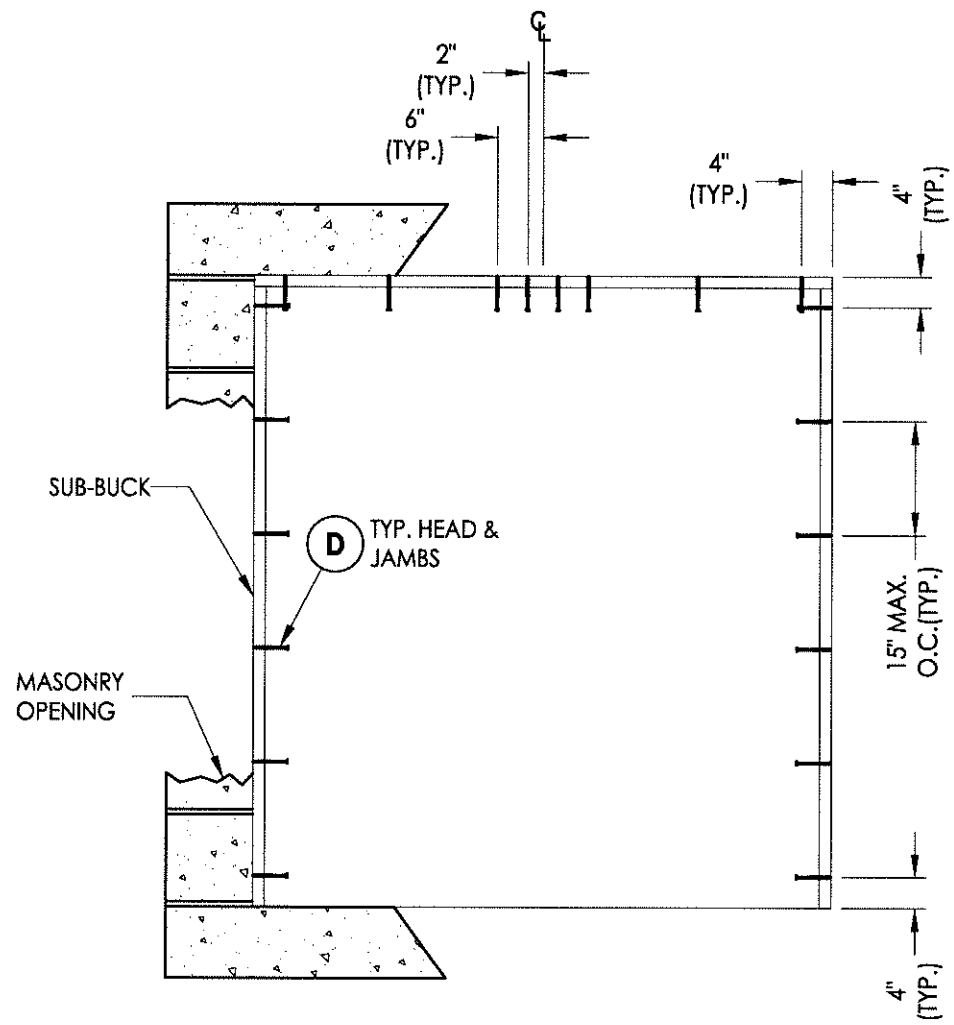

**BUCK ANCHORING**  
Masonry 2X buck construction

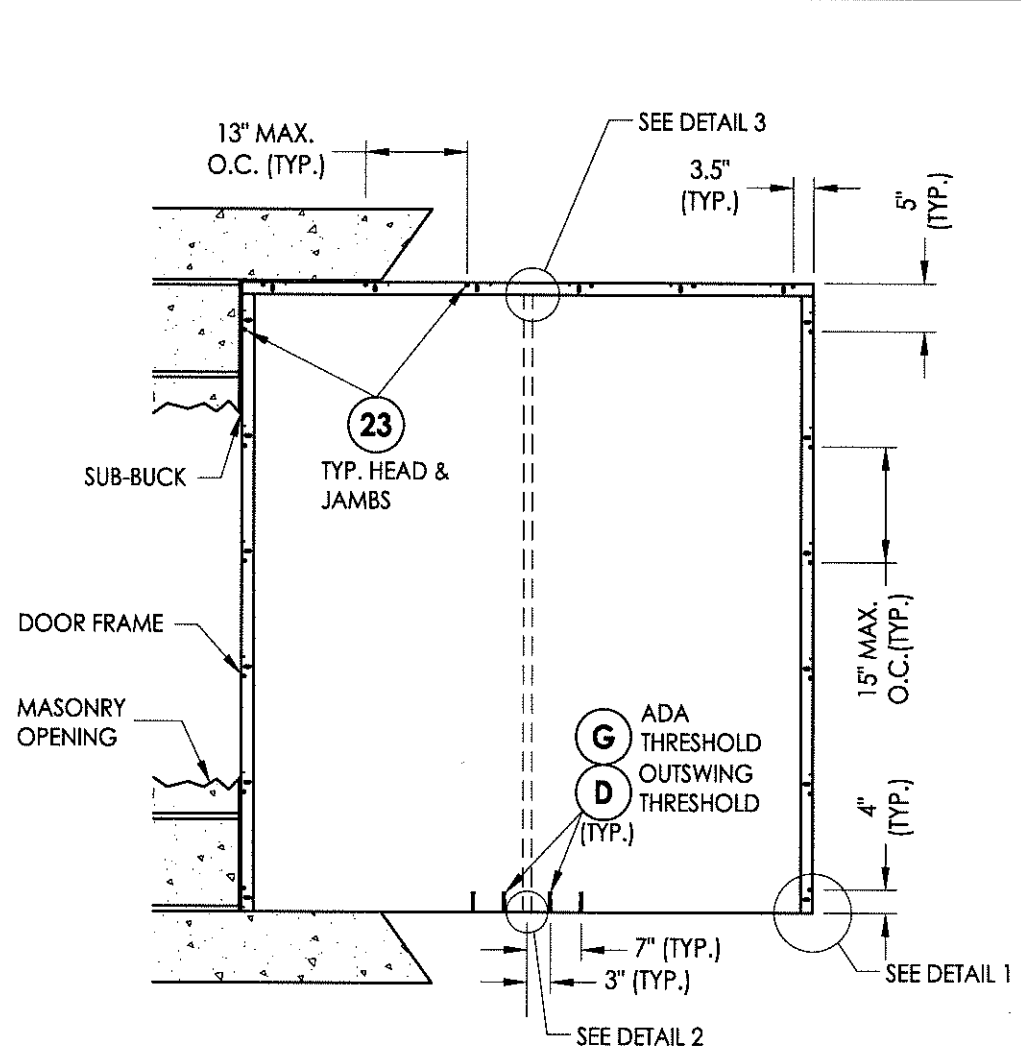

**FRAME ANCHORING**  
Masonry 2X buck construction

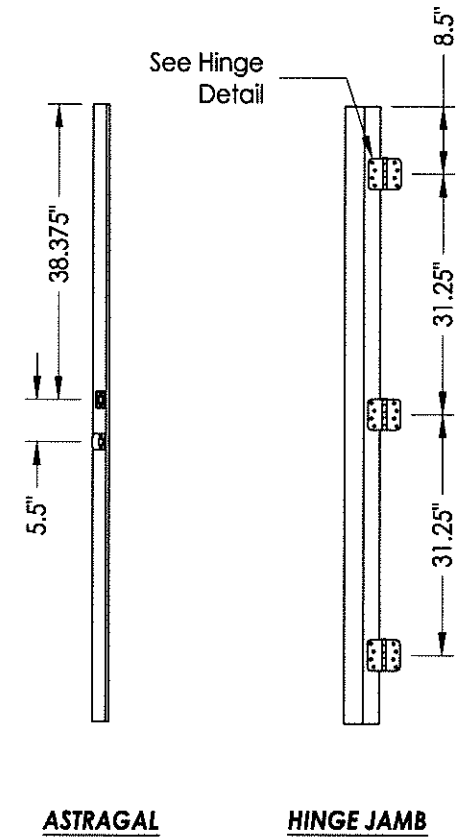

**ASTRAGAL**

**HINGE JAMB**

**CONCRETE ANCHOR NOTES:**

- Concrete anchor locations at the corners may be adjusted to maintain the min. edge distance to mortar joints.
- Concrete anchor locations noted as "MAX. ON CENTER" must be adjusted to maintain the min. edge distance to mortar joints, additional concrete anchors may be required to ensure the "MAX. ON CENTER" dimension are not exceeded.
- Concrete anchor table:

ANCHOR TYPE	ANCHOR SIZE	MIN. EMBEDMENT	MIN. CLEARANCE TO MASONRY EDGE	MIN. CLEARANCE TO ADJACENT ANCHOR
ITW TAPCON®	1/4"	1-1/4"	2"	4"
ELCO ULTRACON®	1/4"	1-1/4"	1"	4"

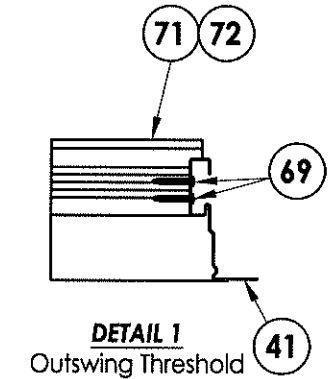
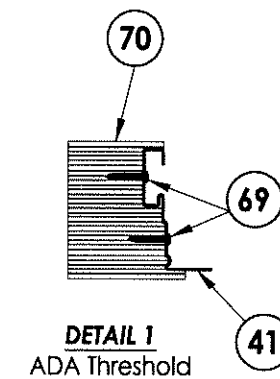
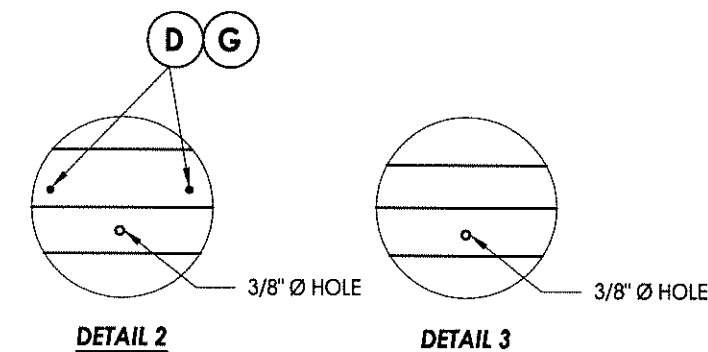
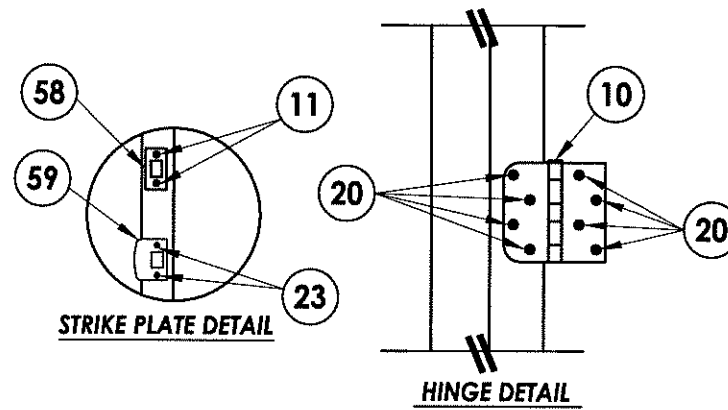

Documents Prepared By: **RW BUILDING CONSULTANTS, INC.**  
P.O. Box 230 Vairco FL 33595  
Phone No.: 813.659.9197  
Florida Board of Professional Engineers  
Certificate Of Authorization No. 9813  
*LFS* 6.12.13  
Lyndon F. Schmidt, P.E. No. 43409

PRODUCT: **DUNBARTON REDIFLEX TWO-PIECE STEEL FRAME**

PART OR ASSEMBLY: **BUCK AND FRAME ANCHORING MASONRY 2X BUCK**

NO.	DATE	BY	REVISIONS

DATE: 6/3/13  
SCALE: N.T.S.  
DWG. BY: JK  
CHK. BY: LFS  
DRAWING NO.: FL-15341.7  
SHEET 6 OF 9

© 2013 R.W. BUILDING CONSULTANTS INC.

R:\VA - Projects\Project Folders\Proj 1601 - 1700\PF 1650\D. RWBC Drawings\FL-15341.1-8.dwg, 7.7

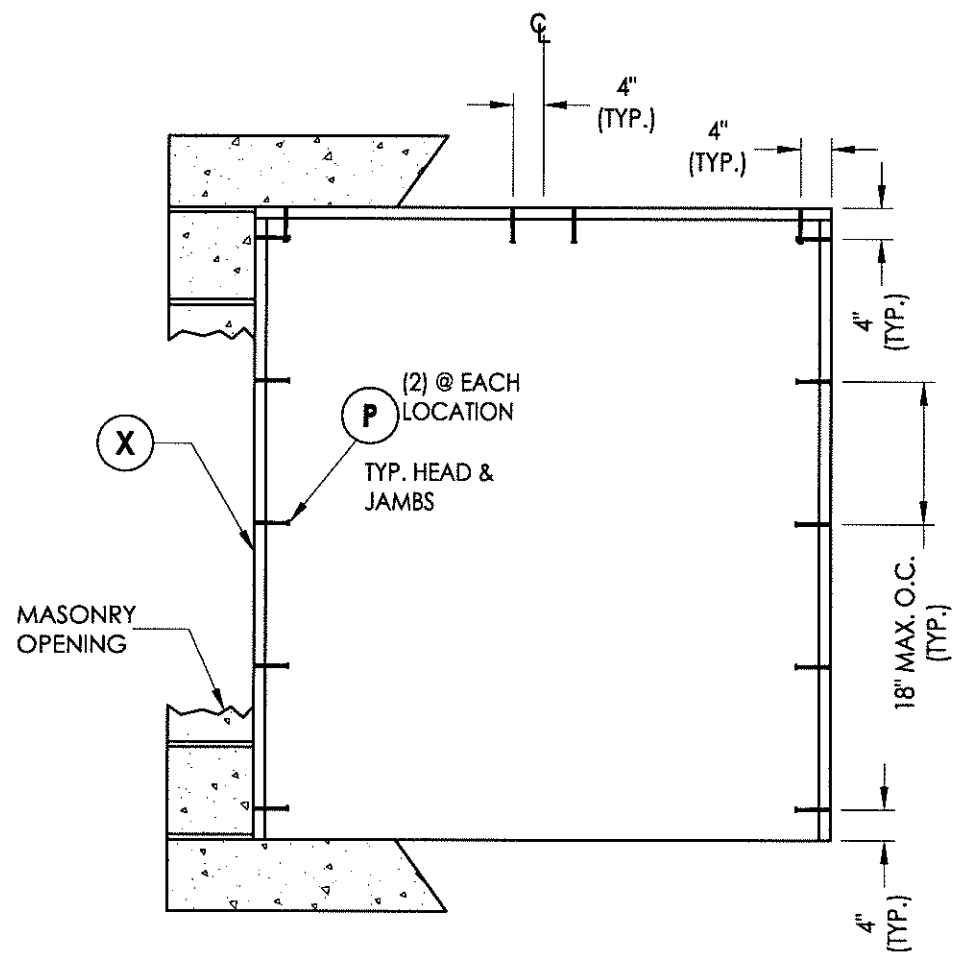

**BUCK ANCHORING**  
Masonry steel stud construction

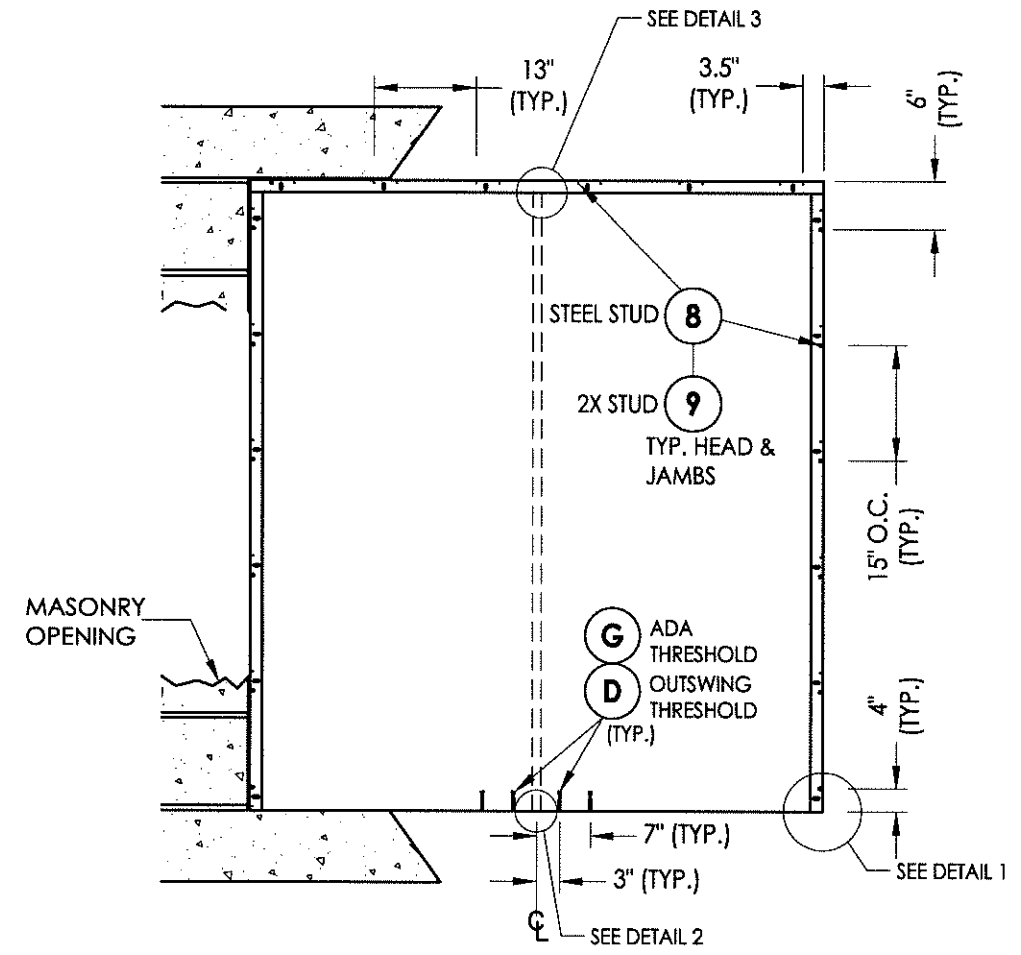

**FRAME ANCHORING**  
Stud construction

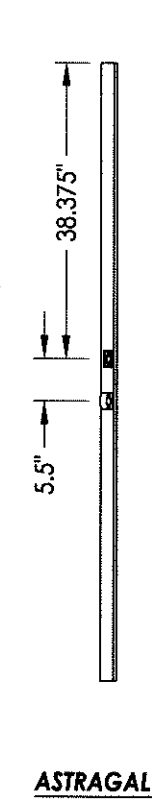

**ASTRAGAL**

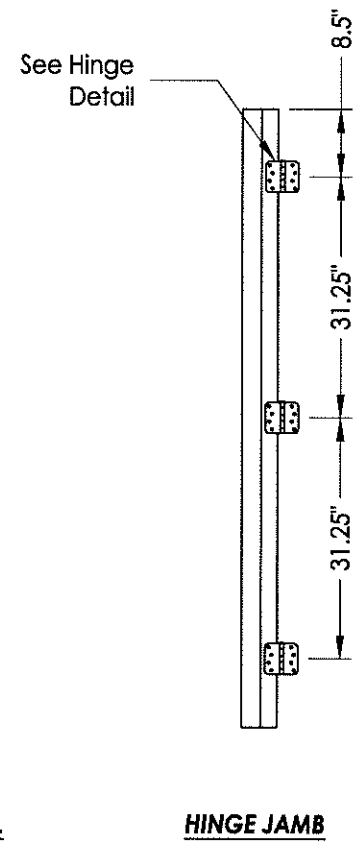

**HINGE JAMB**

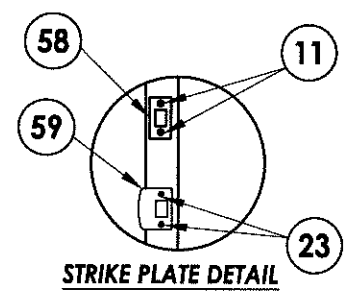

**STRIKE PLATE DETAIL**

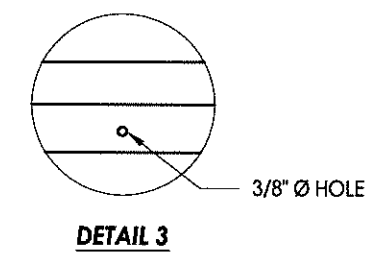

**DETAIL 3**

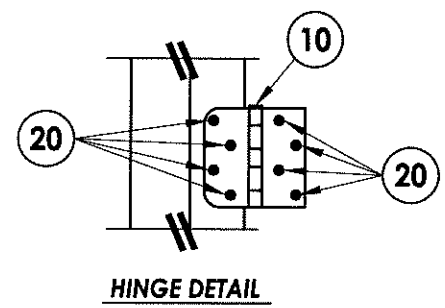

**HINGE DETAIL**

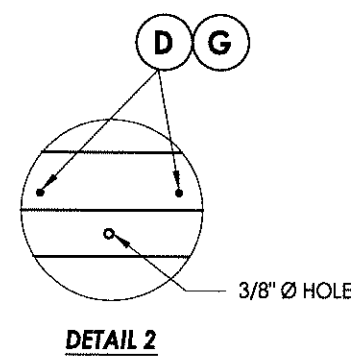

**DETAIL 2**

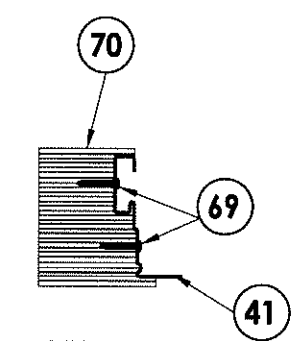

**DETAIL 1**  
ADA Threshold

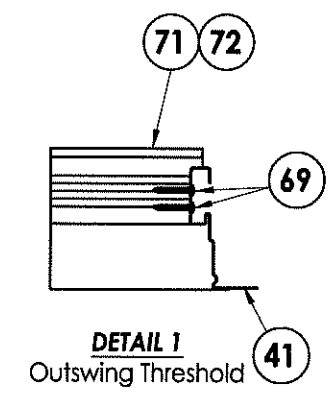

**DETAIL 1**  
Outswing Threshold

- CONCRETE ANCHOR NOTES:**
1. Concrete anchor locations at the corners may be adjusted to maintain the min. edge distance to mortar joints.
  2. Concrete anchor locations noted as "MAX. ON CENTER" must be adjusted to maintain the min. edge distance to mortar joints, additional concrete anchors may be required to ensure the "MAX. ON CENTER" dimension are not exceeded.
  3. Concrete anchor table:

ANCHOR TYPE	ANCHOR SIZE	MIN. EMBEDMENT	MIN. CLEARANCE TO MASONRY EDGE	MIN. CLEARANCE TO ADJACENT ANCHOR
ITW TAPCON®	1/4"	1-1/4"	2"	4" / 3" (steel stud)
ELCO ULTRACON®	1/4"	1-1/4"	1"	4"

Documents Prepared By: **RW BUILDING CONSULTANTS, INC.**  
P.O. Box 230 Valrico FL 33595  
Phone No.: 813.659.9197  
Florida Board of Professional Engineers  
Certificate of Authorization No. 9813  
6-12-13  
Lyndon F. Schmidt, P.E. No. 43409

**PRODUCT:** DUNBARTON REDIFLEX TWO-PIECE STEEL FRAME  
**PART OR ASSEMBLY:** BUCK & FRAME ANCHORING STEEL/2X STUD

NO.	DATE	BY	REVISIONS

DATE: 6/3/13  
SCALE: N.T.S.  
DWG. BY: JK  
CHK. BY: LFS  
DRAWING NO.: FL-15341.7  
SHEET 7 OF 9

© 2013 R.W. BUILDING CONSULTANTS INC.

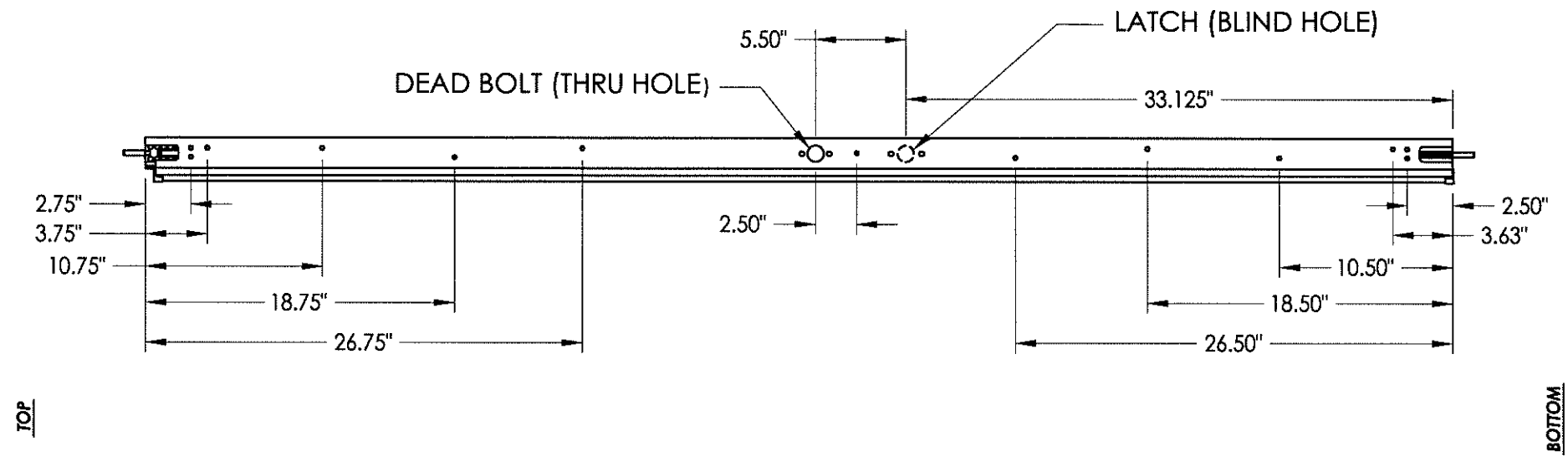

**6'8 ALUMINUM ASTRAGAL ASSEMBLY**  
By Endura Products

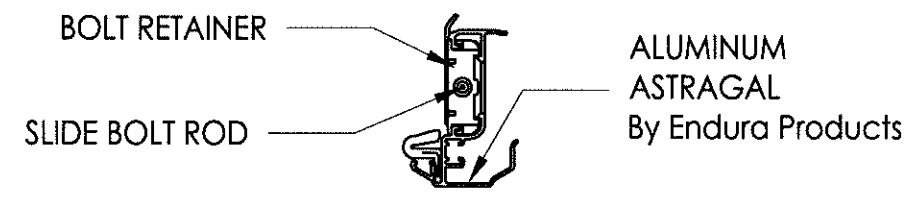

**VIEW A-A**  
Aluminum Astragal Assembly

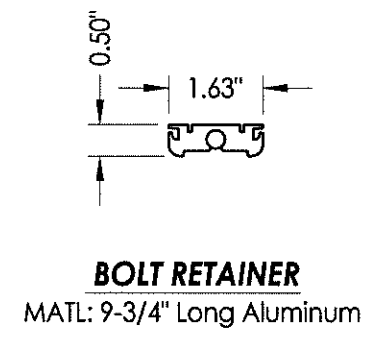
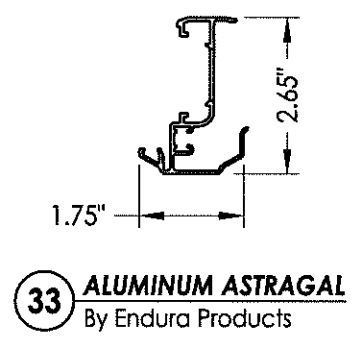
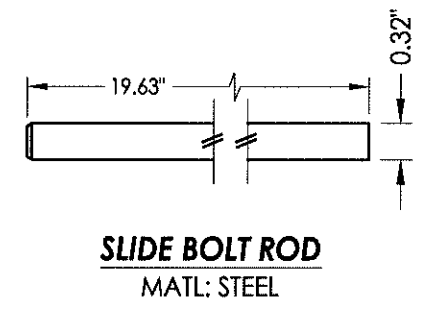

Documents Prepared By: <b>RW</b> BUILDING CONSULTANTS, INC. P.O. Box 230 Valrico FL 33595 Phone No.: 813.659.9197	
Florida Board of Professional Engineers Certificate Of Authorization No. 9813 <b>LFS</b> 6-12-13 Lyndon F. Schmidt, P.E. No. 43409	
PRODUCT:	DUNBARTON REDIFLEX TWO-PIECE STEEL FRAME
PART OR ASSEMBLY:	ASTRAGAL DETAILS
NO.	DATE
BY	REVISIONS
DATE:	6/3/13
SCALE:	N.T.S.
DWG. BY:	JK
CHK. BY:	LFS
DRAWING NO.:	FL-15341.7
SHEET	8 of 9



BILL OF MATERIALS		
ITEM #	DESCRIPTION	MATERIAL
A	2X FRAMING: SG >= 0.55	WOOD
B	2X BUCK SG >= 0.55	WOOD
E	MASONRY - 3,192 PSI MIN. CONCRETE CONFORMING TO ACI 301 OR HOLLOW BLOCK CONFORMING TO ASTM C90	CONCRETE
D	1/4" X 2-3/4" ELCO OR ITW PFH CONCRETE SCREW	STEEL
G	1/4" X 2-1/4" ELCO OR ITW PFH CONCRETE SCREW	STEEL
P	1/4" X 1-3/4" ITW HWH CONCRETE SCREW	STEEL
X	SSMA STUD 550S162-54 (Fy = 33 ksi, Fu = 45 ksi)	STEEL
8	10-16 TEKS SELF-DRILLING SCREW (ITW BUILDEX)	STEEL
9	#6 X 2" PFH WS	STEEL
10	HINGE	STEEL
11	#8 X 2-1/2" PPH SCREW	STEEL
14	#8 x 3/8" PFH WS	STEEL
20	10-24 X 1/2" PFH MS	STEEL
23	#6 X 1-1/2" PFH WOOD SCREW	STEEL
29	JAMB HINGE REIN. 14 GA. 4" x 4" x 1.53" (.075" GALV. STEEL) BY DUNBARTON FR00505	STEEL
30	COMPRESSION WEATHERSTRIPPING QLON QDS 650 BY SCHLEGEL	FOAM
33	ASTRAGAL (ENDURA)	ALUM
41	REDIFLEX JAMB BASE 18 GA. (.042" MIN. GALV. STEEL) BY DUNBARTON	STEEL
42	REDIFLEX JAMB CLOSURE 22 GA. (.026" MIN. GALV. STEEL) BY DUNBARTON	STEEL
50	STEEL DOOR PANEL - by MASONITE	-
58	STRIKE PLATE - DEADBOLT	STEEL
59	STRIKE PLATE - LATCHBOLT	STEEL
69	#8 X 1-1/4" PWH SMS	STEEL
70	ADA THRESHOLD	ALUM
71	OUTSWING THRESHOLD	ALUM
72	HIGH DAM OUTSWING THRESHOLD	ALUM
74	8-32 x 3/8" PFH MS	STEEL

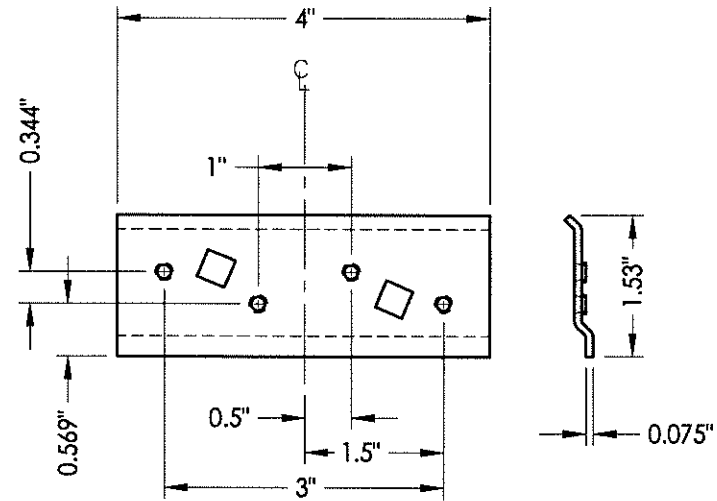

29 HINGE REINFORCEMENT

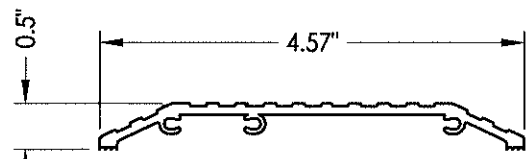

70 ADA THRESHOLD  
Imperial

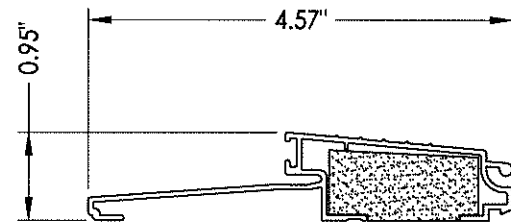

71 OUTSWING THRESHOLD  
Imperial

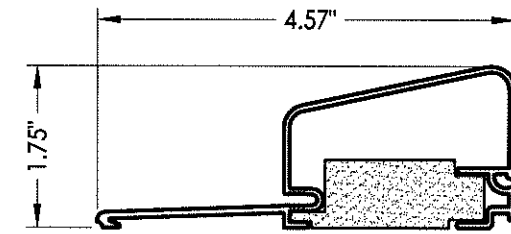

72 HIGH DAM THRESHOLD  
AFCO

Documents Prepared By:

**R.W.** BUILDING CONSULTANTS, INC.  
P.O. Box 230 Vairico FL 33595  
Phone No.: 813.659.9197  
Florida Board of Professional Engineers  
Certificate Of Authorization No. 9813  
*LFS* 6-12-13  
Lyndon F. Schmidt, P.E. No. 43409

PRODUCT:  
DUNBARTON REDIFLEX  
TWO-PIECE STEEL FRAME

PART OR ASSEMBLY:  
BILL OF MATERIALS  
& COMPONENTS

NO.	DATE	BY	REVISIONS

DATE: 6/3/13  
SCALE: N.T.S.  
DWG. BY: JK  
CHK. BY: LFS  
DRAWING NO.:  
FL-15341.7  
SHEET 9 OF 9