

Owner's/Operator's Manual

Model 6TS Submersible Turbine

INSTALLATION / OPERATION MAINTENANCE

**This pump should be serviced
by authorized personnel only.**

**For more information,
please call Berkeley Pumps
at 1-888-237-5353 or contact
your local Berkeley Distributor.**

Table of Contents:

Safety	1
General	1
Specifications	2
Pre-Installation Procedures and Checks	2-3
Installation	3-5
Submergence	3
Three-Phase Current Unbalance	5
Service	6-7
Pump Disassembly/Assembly	7-10
Preventative Maintenance	10
Troubleshooting	11
Repair Parts	12-15
Warranty	16

READ AND FOLLOW SAFETY INSTRUCTIONS!

⚠ This is the safety alert symbol. When you see this symbol on your pump or in this manual, be alert to the potential for personal injury.

⚠ DANGER warns about hazards that **will** cause serious personal injury, death or major property damage if ignored.

⚠ WARNING warns about hazards that **can** cause serious personal injury, death or major property damage if ignored.

⚠ CAUTION warns about hazards that **will** or **can** cause minor personal injury or property damage if ignored.

The label **NOTICE** indicates special instructions which are important but not related to hazards.

Carefully read and follow all safety instructions in this manual and on pump.

Keep safety labels in good condition.

Replace missing or damaged safety labels.

GENERAL CONSIDERATIONS

Before installing your submersible turbine pump, review the following checklist.

Be sure the well is clear of sand and abrasive material before installing pump. Abrasive materials in the water cause component wear and reduce pump capacity and discharge pressure. Never use the pump to develop or clean the well. Permanent pump damage can result within the first few hours of operation.

If the well casing is suspected of being crooked, check it with a gauge of identical length and diameter as the pump and motor with two lengths of pipe attached. Serious damage can result if the pump becomes lodged in a crooked casing.

Be sure the well can supply a high-capacity turbine pump. The well should be deep enough to cover the pump unit with water, even at extreme pumping rates. Typically, the pump should be submerged 10 to 20 feet below the lowest water level and at least 5 feet above the bottom of the well.

Air entrained in the water reduces performance and will damage the pump.

Your pump is designed to provide maximum efficiency under specific capacity and head conditions. Do not operate it beyond specified limits.

System controls and pump must match. Do not interchange controls with other models. Serious damage can result to the unit if pump and controls do not match.

Average number of starts per day will influence motor and control component life (starters, relays, capacitors, etc). Select pump size, tank size and control components for lowest practical number of starts per day. Excessive cycling accelerates bearing, spline, and pump wear and control contact erosion.

SPECIFICATIONS

Table I: Frequency of Starts

Average Number of Starts per Hour		
HP Rating	Single Phase	Three Phase
1 to 50	15	15

Table II: Weight of Pipe (Column)

Weight per Foot (Lbs)		
Pipe Size (In)	Full	Empty
2-1/2	7.9	5.8
3	10.8	7.6
4	16.3	10.8
5	23.3	14.62
6	31.5	18.97

Table III: Weight of Cable per 1000 Ft. (lbs.)

AWG Size	3-Phase		1-phase	
	Nom. Dia.	Weight	Nom. Dia.	Weight
12-3	.500	140	.487	130
10-3	.545	186	.517	161
8-3	.771	328	.750	293
6-3	.965	525	.826	400
4-3	1.071	717		
2-3	1.243	1066		

Table IV: Cable Wire Resistance

AWG Wire Size	Resist (Ohms/Ft)
14	.0050
12	.0032
10	.0020
8	.0013
6	.0008
4	.0005
2	.0003

**Table V: Cooling Flow Rates Past Submersible Motors In Feet Per Second (FPS)
6" Nominal Motor (5.38" OD)**

Casing Size	GPM												FPS
	20	40	60	80	100	120	140	160	180	200	220	240	
6" ID	1.2	2.3	3.5	4.6	5.8	7.0	8.1	9.3	10.4	11.6	12.7	13.9	}
8" ID	-	0.5	0.7	0.9	1.2	1.4	1.6	1.9	2.1	2.3	2.6	2.8	
10" ID	-	-	0.3	0.5	0.6	0.7	0.8	0.9	1.0	1.1	1.3	1.4	

Formula to find flow rate:

$$FPS = \frac{GPM \times .409}{D1^2 - D2^2}$$

D1 = Casing inside diameter
D2 = Motor outside diameter

NOTICE: If flow rate past motor is expected to be less than rate shown in table, install a shroud around motor to force cooling flow past shell. To minimize erosion to shell if flow

PREINSTALLATION PROCEDURES AND CHECKS

Electrical Splices and Connections

Splices must be waterproof. Make a strong mechanical bond between the motor leads and the cable to avoid high resistance at the connection. A poor mechanical connection, or a poorly wrapped splice, can cause motor problems and motor failure.

Before connecting the motor to the cable, perform a ground check to assure that the motor has not been damaged. Attach one end of an ohmmeter lead to any of the three motor leads and the other ohmmeter lead to the pump intake bracket. A new motor must have a resistance of 2 megohms or greater. If not, contact your dealer. Repeat for all three leads.

Prepare the cable and make the mechanical connections (Figure 1A) and splices as follows:

1. Cut motor leads and corresponding cable ends at 3-inch spacings to stagger connections for a smooth splice.
2. Cut connecting cable to match the motor leads. **NOTICE:** Match color coded wires, red to red, black to black, and white to white.
3. When using a butt connector, expose bare wire for about 1/2". When using stranded wire, expose about 1" of wire.

NOTICE: Butt connectors may be used with solid wires through 8 AWG, or stranded wires through 10 AWG.

4. Clean exposed ends of wire thoroughly with emery cloth or sandpaper to assure good electrical connections.

5A. BUTT CONNECTORS (Figure 1A): Insert wires into connector until insulation butts up against connector. Crimp connector to wires with a pair of crimping pliers. Pull on cable to make sure the connection is solid and tight.

5B. SOLDERED CONNECTIONS (Figure 1A):

NOTICE: Do not use acid core solder or corrosive solder paste.

- I. Straighten individual cable strands and spread apart slightly.
- II. Clean each strand and push strands of cable into matching (color-coded) open strands of the motor leads.
- III. Wrap entire length of joint with fine copper wire until strands are compressed.

rate is expected to be more than 10 FPS (especially if sand is present), reduce flow through pump to reduce flow past shell.

IV. Apply heat and solder. Solder will follow the heat; make sure solder flows throughout the joint. Pull firmly on cable to test joint.

6. Repeat Step 5 for each lead.

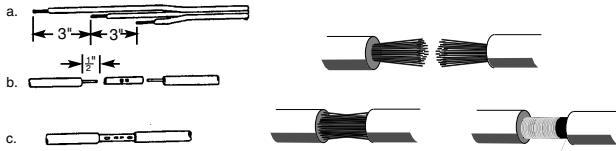

Figure 1A: Cable Splicing: Solid Wire, Stranded Wire

7. Taping splice (Figure 1B):

CAUTION Because friction tape is not water resistant, never use friction tape on a water-tight splice. Use Scotch Number 33, or equivalent.

7A. Clean joints and adjoining cable/wire insulation of all grease and dirt, and build up joint area with tape until it matches diameter of cable.

7B. Starting 1-1/2" back from the joint, firmly apply one layer of tape, overlapping about half the previous lap and continuing approximately 1-1/2" beyond joint. Cut tape evenly and press both ends firmly against cable.

7C. Apply two additional layers of tape, as described in Step 7B, beginning and ending 1-1/2" beyond the previous starting/ending points.

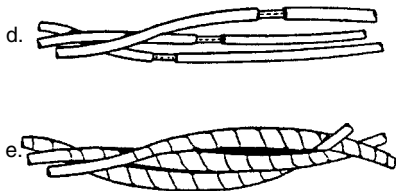

Figure 1B: Stagger splices and tape

Splice and Cable Continuity Test

Before installing pump check cable and splices as follows (see Figure 1C):

1. Submerge cable and splice in steel barrel filled with water. Make sure both ends of cable are out of water.
2. Clip one ohmmeter lead to barrel. Test each lead in cable successively by connecting the other ohmmeter lead to the three cable leads, one after the other.
3. If resistance reading goes to zero on any cable lead, a leak to ground is present. Pull splice out of water. If meter reading changes to "infinity" (no reading) the leak is in the splice.
4. If leak is not in splice, slowly pull cable out of water until reading changes to "infinity". Reading will change to "infinity" when leak comes out of water.
5. Repair cable by splicing as explained under "Electrical Splices and Connections".

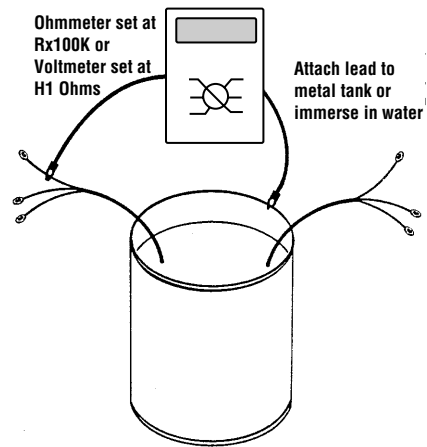

Figure 1C: Splice and Cable continuity

Rotation Check (3-Phase Only)

After satisfactorily completing continuity test, connect cable to pump controller. Check 3-phase motors for correct rotation. If necessary, reverse any two cable leads at the controller and recheck rotation. Permanently mark and match to control box terminals for future reference. Connect cable to motor controller and then wire controller to disconnect switch. Connect temporary jumper wire between proper terminals in controller to temporarily energize magnetic coil.

Momentarily engage disconnect switch and note direction of rotation. The shaft should rotate counterclockwise when viewed from the top or shaft end of the motor. If rotation is incorrect, reverse any two wires; mark wires to correspond with the controller terminal numbers.

NOTICE: Pump is water lubricated. Do not operate the pump for more than 5 seconds while it is out of water.

INSTALLATION

General

After completing all connections and tests so far, connect a 5-foot length of pipe to pump.

Lower pump into well with pipe clamps attached to the 5-foot pipe. Attach a standard length of pipe to 5-foot length and lower pump CAREFULLY into well.

NOTICE: Do not use a pipe longer than 5 feet for the first connection. Hoisting pump upright with a long length of pipe can cause pump misalignment from excessive leverage.

CAUTION Use extreme care when lowering pump and cable to avoid damage to cable insulation.

Anchor power cable to pipe every 20 feet with adjustable steel band clamps. Protect insulation from clamps with pieces of split rubber hose inserted between clamps and cable. Attach cable to pipe halfway between clamps with waterproof tape (Scotch No. 33 or equivalent).

Submergence

Be sure the pump is always submerged, even at extreme pumping rates. Install pump at least 10 to 20 feet below the lowest "drawdown" water level and at least 5 feet above bottom of well.

Check Valves

Pump back spin and hydraulic shock can cause severe damage to the pump and motor. Install at least one check valve in the discharge pipe (riser pipe) to help prevent this.

Install the first check valve in the pump discharge or in the discharge pipe itself, not more than 25' above the pump. Install another check valve not more than 200 feet above the first one. Repeat, all the way up the riser pipe. The last check valve on the riser pipe should be not more than 200' below the surface. Finally, install a check valve near the well head in the horizontal pipe at the surface (see Figure 2).

NOTICE: To avoid water hammer and pipe breakage, **do not** put a check valve exactly half-way up the riser pipe (that is, with equal distance down to the pump and up to the surface), especially if it is the only check valve in the riser pipe after the pump discharge check. The 'equal distance' in both legs of the pipe can allow resonations from water hammer which can blow the pump off the riser pipe.

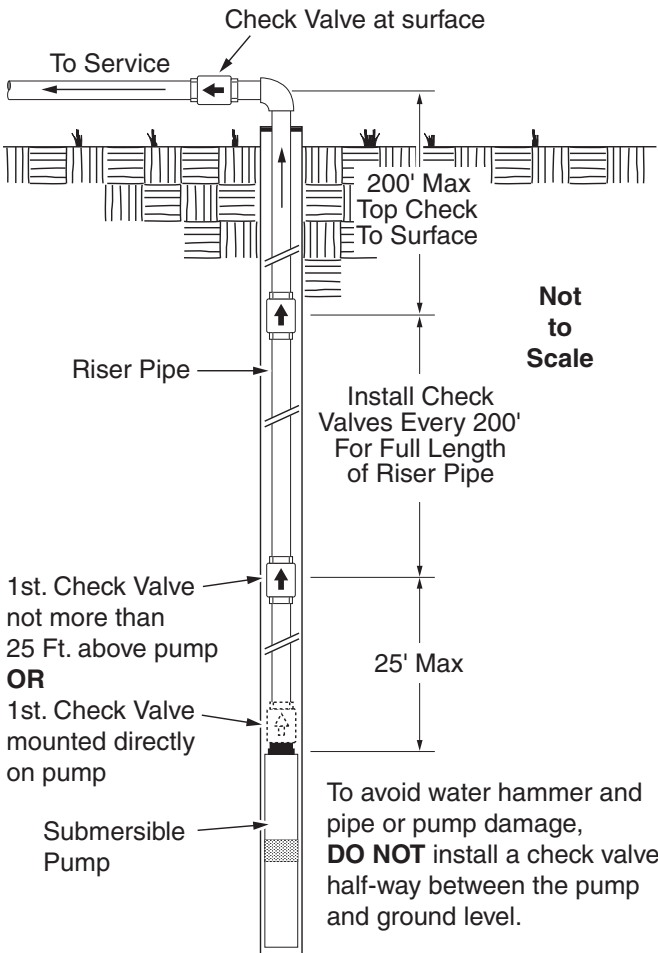

Figure 2: Check Valve Location

Well and Pump Test

Check and record static water level of well before starting tests. Before making final piping connections, test flow rate, capacity, and condition of well.

NOTICE: Do not operate pump with discharge valve closed. Operate pump only within pressure and flow limits of operating range established by performance curve.

NOTICE: If sand is present in discharge, allow pump to run with discharge completely open until water is clear. If loud rattling noises develop, pump is probably cavitating. Gradually close discharge valve until rattling stops.

INSTALLATION - ELECTRICAL TESTS

▲ WARNING Risk of high voltage electrical shock when testing. Can stun, burn, or kill.

Only qualified electricians should perform these tests. When testing, use all normal precautions for the voltages involved.

Electrical test of motor, cable, connections

The cable and splices can be damaged as the pump is lowered into the well. To electrically test them, attach one lead of ohmmeter to pipe. Attach other lead to each cable lead in turn. See motor owner's manual for required resistance in a good motor. A low reading indicates that cable or splice has developed a leak to ground. Remove pump from well and correct problem before proceeding with installation.

Measure electrical resistance between motor leads and well casing when motor is cold.

Voltage test (Figure 3)

Low or high voltages can cause motor failure. While pump is operating, check voltage across each pair of leads at motor controller. Readings more than 10% above or below rated nameplate voltage can damage pump; correct before placing pump in service. Test as follows:

1. Disconnect main power supply and open controller.
2. Connect power and start pump. For 3-phase motors, read voltage across three pairs of leads (L1 – L3, L3 – L2, L2 – L1) while pump is operating. For single phase motors, read voltage across L1 and L2 while pump is operating. Voltage should be within $\pm 10\%$ of motor nameplate rated voltage. If not, consult power company.

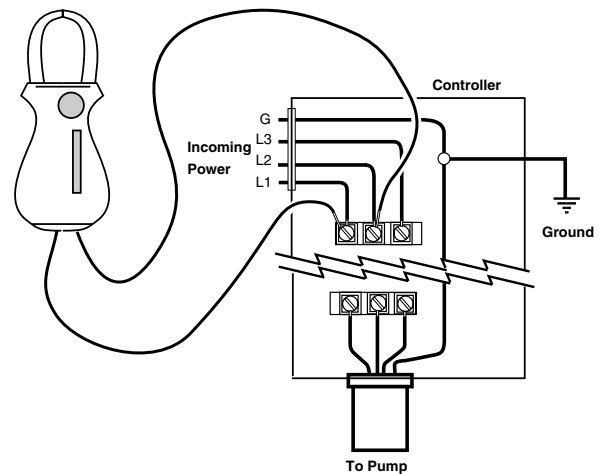

Figure 3: Voltage Test

Load current test (Figure 4)

Load current should be obtained on each motor lead at the controller. Partially close pump discharge valve (keep pressure and flow within specified operating range) until

maximum amp reading has been obtained. Compare reading with motor nameplate rating. If reading is 15% or more over rated load, check for incorrect voltage in supply line or overload due to abrasives in pump. Find and correct problem before putting pump in service.

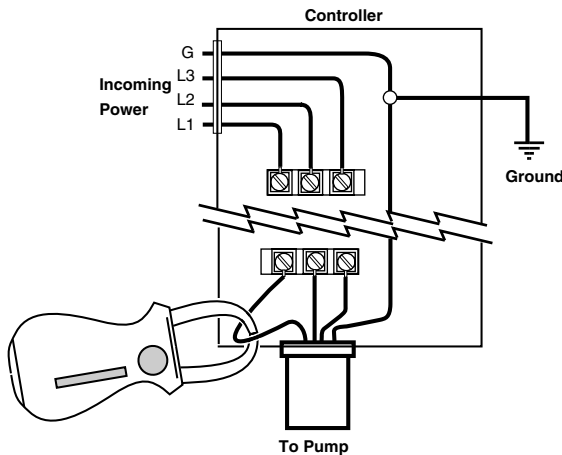

Figure 4: Load Current Test

Current unbalance test (3 Phase only)

Determine current unbalance by measuring current in each power lead. Measure current for all three possible hookups. Use example and worksheet (Page 5) to calculate current unbalance on a three phase supply system and retain for future reference.

NOTICE: Current unbalance should not exceed 5%. If unbalance cannot be corrected by rolling leads, locate and correct source of unbalance.

If, on all three possible hookups, the reading furthest from average stays on the same power lead, most of the unbalance is coming from the power source.

However, if the reading furthest from average changes leads as the hookup changes (that is, stays with a particular motor lead), most of the unbalance is on the "motor side" of the starter. In this case, consider a damaged cable, leaking splice, poor connection, or faulty motor winding.

Current Unbalance Example and Worksheet

3-Phase Current Unbalance - Example

Here is an example of current readings at maximum pump loads on each leg of a three wire hookup. Make calculations for all three possible hookups.

A. For each hookup, add the readings for the three legs:

Ex.: Hookup #1	Hookup #2:	Hookup #3
L1 = 51Amps	L1 = 50 Amps	L1 = 50 Amps
L2 = 46 Amps	L2 = 48 Amps	L2 = 49 Amps
L3 = 53 Amps	L3 = 52 Amps	L3 = 51 Amps
Total 150 Amps	Total 150 Amps	Total 150 Amps

B. Divide each total by three to get average amps:
 Example: 150/3 = 50
 Example: 150/3 = 50
 Example: 150/3 = 50

C. For each hookup, find current value farthest from average (Calculate the greatest current difference from the average).

Ex. #1	Ex. #2	Ex. #3
50 Amps	50 Amps	50 Amps
-46 Amps	-48 Amps	-49 Amps
= 4 Amps	= 2 Amps	= 1 Amps

D. Divide this difference by the average and multiply by 100 to obtain the percentage of unbalance. Example:
 Ex. 1: 4/50 = .08 x 100 = 8%
 Ex. 2: 2/50 = .04 x 100 = 4%
 Ex. 3: 1/50 = .02 x 100 = 2%

Use smallest percentage unbalance, in this case Ex. 3.

3-Phase Current Unbalance - Worksheet

Use this worksheet to calculate current unbalance for your installation.

A. Add the readings for the three legs:

Ex.: Hookup #1	Hookup #2:	Hookup #3
L1 = Amps	L1 = Amps	L1 = Amps
L2 = Amps	L2 = Amps	L2 = Amps
L3 = Amps	L3 = Amps	L3 = Amps
Total Amps	Total Amps	Total Amps

B. Divide each total by three to get average amps:
 Hookup #1: /3 =
 Hookup #2: /3 =
 Hookup #3: /3 =

C. For each hookup, find current value farthest from average (Calculate the greatest current difference from the average).

Hookup #1	Hookup #2	Hookup #3
Amps	Amps	Amps
Amps	Amps	Amps
Amps	Amps	Amps

D. Divide this difference by the average to obtain the percentage of unbalance:
 Hookup #1: / = x100 = %
 Hookup #2: / = x100 = %
 Hookup #3: / = x100 = %

Use hookup with smallest percentage unbalance.

Table VI: 6TS-Mixed Flow Shaft Spacer and Bearing Journal Lengths in Inches (mm)
(See Exploded View, Page 14)

Model No.	Inlet Shaft Spacer Key No. 19	Thrust Shaft Spacer Key No. 15	Distance Sleeve Key No. 11	Stage Spacer Key No. 10	Disch. Shaft Spacer Key No. 7	Bearing Journal Key No. 6
6TS-115	3.738 (89.30)	1.356 (34.44)	2.896 (73.56)	4.37 (111.00)	0.620 (15.74)	1.749 (44.40)
6TS-155	3.687 (93.65)	1.407 (35.74)	2.845 (72.28)	4.37 (111.00)	0.671 (17.04)	1.749 (44.40)
6TS-230	3.789 (96.24)	1.295 (32.90)	2.957 (75.10)	4.37 (111.00)	0.577 (14.66)	1.749 (44.40)
6TS-300	3.967 (100.75)	0.860 (21.85)	3.3917 (86.15)	4.37 (111.00)	0.400 (10.16)	1.749 (44.40)

Table VII: 6TS-Radial Flow Shaft Spacer and Bearing Journal Lengths in Inches (mm)
(See Exploded View, Page 12)

Model No.	Inlet Shaft Spacer Key No. 16	Stage Spacer Key No. 14	Disch. Shaft Spacer Key No. 12	Bearing Journal Key No. 6
6TS-70	3.219 (81.75)	1.752 (44.50)	1.606 (40.81)	1.749 (44.40)
6TS-140	3.516 (89.30)	1.752 (44.50)	2.291 (58.20)	1.749 (44.40)

SERVICE

General

When installed in a clear well and operated under normal conditions, the submersible turbine pump requires no special maintenance. The hermetically sealed motor is pre-filled and self-lubricating. Completely tested at the factory, it should provide many years of dependable service. The motor is a continuous duty type and can operate continuously for long periods.

Removing Pump From Well

Most pump problems are caused by above-ground electrical problems. Minor control box components or outside electrical difficulties (such as low voltage) can cause a malfunction. Before removing pump from well, check motor windings for damage (check winding resistance with an ohmmeter – see Page 7). Eliminate all above-ground trouble causes before pulling pump. Pull the pump only as a last resort.

Sandlocked Pump:

NOTICE: Before pulling pump, make all possible above ground electrical tests. Most submersible pump problems are above ground, not in the pump itself.

NOTICE: Motor failure can result from starting a sandlocked pump. Do not bypass overload circuit or exceed electrical rating when trying to start a siezed pump.

Remove a sandlocked pump from well for cleaning. To prevent pump from locking again when reinstalled, clean the well thoroughly before reinstalling the pump.

Cleaning Sandlocked Pump:

1. Insert a reducing bushing in discharge adapter cap to receive a hose coupling.
2. Use a hose to flush pump backwards (discharge to suction). Oscillate shaft backwards and forwards with a pump pliers and backwash pump for several minutes.

Checking Pump Performance:

Water containing abrasives can cause impeller wear and reduce impeller efficiency, resulting in overload conditions. In such cases, it is necessary to remove the pump from the well and replace the impellers to maintain capacity and pressure. To assure quality and integrity of the unit, have your pump serviced by authorized Berkeley personnel.

ELECTRICAL TEST

The following electrical checks can be made with pump installed.

⚠ WARNING Risk of high voltage electrical shock when testing. Can stun, burn, or kill. Only qualified electricians should perform these tests. When testing, use all normal precautions for the voltages involved.

Circuit (Winding) Resistance Test (Figure 5)

1. Shut off main power supply and disconnect motor wires.
2. Attach two ohmmeter leads to pairs of cable wires in turn (black and red wires on three wire single phase units). Compare readings with data provided in motor manual.
3. If reading is considerably higher than chart, an open circuit (broken wire) is indicated; if reading is considerably lower, a short circuit is indicated. In either case, remove pump from well and repair unit.

NOTICE: Be sure to include cable and winding resistance. Multiply cable length by the per-foot cable resistance (see Table IV, Page 2) and add winding resistance from motor chart to get total.

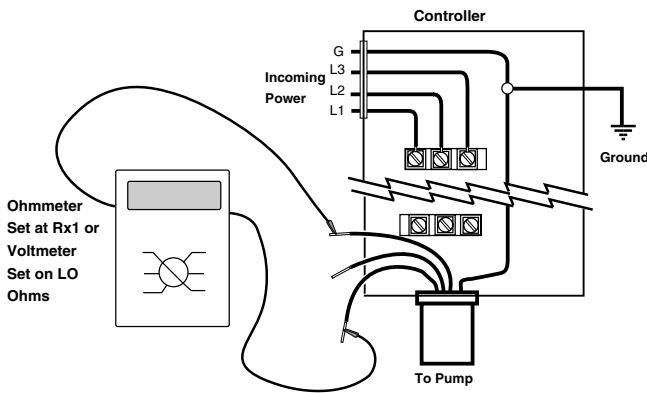

Figure 5: Circuit (Winding) Resistance Test

Ground Check (Figure 6)

1. Shut off main power supply and disconnect motor wires.
2. Attach one ohmmeter lead to pipe or METAL well casing and the other lead, in turn, to each individual motor wire.

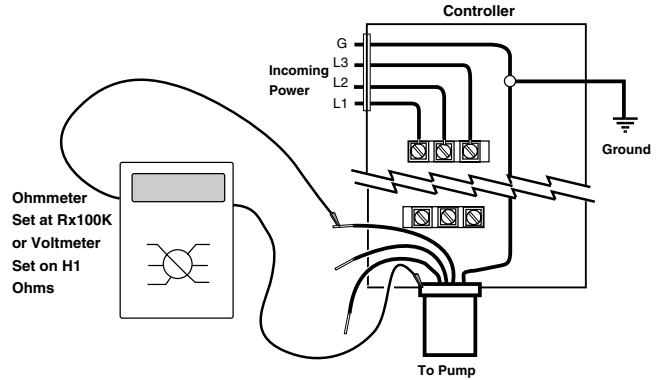

Figure 6: Ground Check

3. If resistance reading goes to zero after touching any of the wires, the pump should be raised to determine location of ground fault (cable, motor, or splice).
4. Raise pump, watching resistance reading. When resistance goes to infinity, fault has come out of the water. If ground fault is located in cable or splice, repair it.
5. If ground fault appears to be located in motor, remove pump from well. Cut cable at motor side of splice and determine whether or not motor is grounded. If motor indicates complete ground (resistance reading goes to zero) replace unit.

If motor is not grounded, re-check splice and cable.

DISASSEMBLY – RADIAL FLOW

Please refer to the exploded view on Page 12 for Key No. references.

NOTICE: Do not use any sharp tools that could damage parts. Only gentle tapping with a rubber mallet needs to be applied to release parts.

1. Remove the Suction Strainer, Coupling Strainer (Key Nos. 23 and 25), Cable Guard Clamps and Cable Guard (Key Nos. 21 and 22).

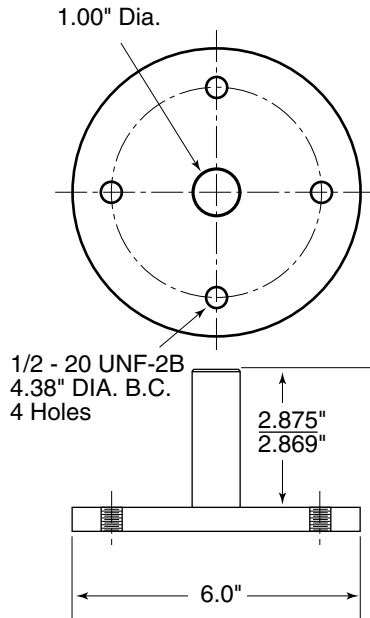

Figure 7: Assembly fixture dimensions for 6" motor; stickup is motor height.

2. Loosen and remove the four M12 bolts and washers (Key Nos. 18 and 19) and remove the straps.
3. Gently tap the Discharge (Key No. 1) and remove it.
4. Remove the Check Valve Poppet, Check Valve Flange, and Bearing Housing Assembly (Key Nos. 2, 3, and 7).
5. Remove the Shaft Compression Screw (Key No. 4) from the top of the Shaft (Key No. 26).
6. Remove the Rotor Compression Washer, Bearing Journal, Stainless Steel Washer, Fiber Washer, and Thrust Washer (Key Nos. 4, 5, 6, 8, 9, and 10) from the Shaft.
7. Tap the Bowls (Key No. 11) with a rubber mallet to loosen them. Slide the Bowls, Impellers (Key No. 13), and Stage Spacers (Key Nos. 12 and 14) off the Shaft.
8. Remove the Inlet Stage Spacer (Key No. 16) from the Shaft.
9. Finally, remove the Pump Shaft and Coupling from the Suction Bracket (Key No. 24).

ASSEMBLY

Please refer to the exploded view on Page 12 for Key No. references.

1. Clean and straighten the Pump Shaft (Key No. 26) until TIR is 50 to 100 microns (.002" to .004").
2. Slide the Coupling (Key No. 27) onto the Pump Shaft until the end of the shaft aligns with the end of the hex portion of the coupling. Lock the Coupling to the Pump Shaft with two Allen Screws (Key No. 28).
3. Install the Shaft and Coupling in the Suction Bracket.
4. Bolt the Suction Bracket (Key No. 24) to the Assembly Fixture (See Figure 6 for Fixture specifications). Make sure that the Shaft Assembly is correctly aligned and is down solidly on the Fixture.
5. Slide the Inlet Shaft Spacer (Key No. 16) down over the Shaft and seat it on the Coupling.
6. Slide the First Stage Bowl (Without diffuser – Key No. 15) down over the Shaft and seat it on the Suction Bracket.
7. Slide an Impeller (Key No. 13) over the Shaft until it rests on the Inlet Shaft Spacer. Follow it with a Stage Spacer (Key No. 14) in a multi-stage pump, or the Discharge Shaft Spacer (Key No. 12) in a single-stage pump. (Single-stage pumps skip to Step 11).
8. Slide a Bowl (with diffuser – Key No. 11) over the Shaft and seat it by gently tapping it with a rubber mallet.
9. Slide an Impeller (Key No. 13) over the Shaft until it rests on the Stage Spacer. Follow it with another Stage Spacer (Key No. 14) if you have more impellers to install, or with the Discharge Shaft Spacer if this was the last impeller.
10. Repeat steps 8 and 9 until you have no more impellers to install.
11. When all the stages with impellers are completed, slide the last Bowl (without Impeller) over the shaft until it rests on the next-to-last Bowl (with impeller). Seat it with a rubber mallet.
12. Slide the Thrust Washer (Key No. 10) over the shaft until it rests on the Discharge Shaft Spacer.
13. Slide the Bearing Journal (Key No. 6) over the Shaft and rest it on the Stainless Steel Washer.
14. Slide the Fiber Washer and Stainless Steel Washer (in that order - Key Nos. 9 and 8) over the bearing journal until they rest on the thrust washer.
15. Put the Rotor Compression Washer (Key No. 5) on the Bearing Journal and lock it with the Shaft Compression Screw (Key No. 4).
NOTE: Use Loctite Threadlocker® on the capscrew threads.
16. Mount the Bearing Housing Assembly (Key No. 7) on the top Bowl.
17. Install the Check Valve Flange and the check Valve Poppet (Key Nos. 3 and 2) on the Bearing Housing Assembly.

18. Install the Discharge (Key No. 1) on the Check Valve Flange and seat it by gently tapping it with a rubber mallet. Be sure that the strap slots in the discharge are clean.
19. Hook the four Straps (Key No. 20) onto the Discharge and loosely fasten them to the Suction Bracket Assembly with Lock Washers, Hex Head Bolts, and Strap Nuts (Key Nos. 18,19, and 17).
20. Tighten the four Straps evenly to 6.5 kilogram meters (47 ft.-lbs.) torque. Be sure that the straps seat completely in the discharge.
21. Check the axial clearance of the pump shaft (2.5 to 3 mm. or 3/32 to 1/8").
22. Check the pump for free rotation.
23. Install the Suction Strainer (Key No. 23) with pop rivets.
24. Install the Cable Guard Clamps and Cable Guard (Key Nos. 21 and 22) on the pump.
25. Remove the pump from the fixture and install the Coupling Strainer (Key No. 25).

The pump is ready for installation.

DISASSEMBLY – MIXED FLOW

Please refer to the exploded view on Page 14 for Key No. references.

NOTICE: Do not use any sharp tools that could damage parts. Only gentle tapping with a rubber mallet needs to be applied to release parts.

1. Remove the Cable Guard (Key No. 23) and the Suction and Coupling Strainers (Key Nos. 24 and 26).

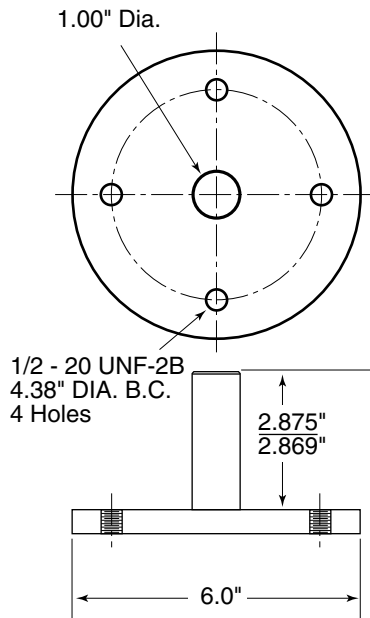

Figure 8: Assembly fixture dimensions for 6" motor; stickup is motor height.

2. Loosen and remove the four M12 bolts and washers (Key Nos. 18 and 17) and remove the straps.
3. Gently tap the Discharge (Key No. 1) and remove it.
4. Remove the check valve poppet and the top bowl (Key Nos. 2 and 3).
5. Loosen the Rotor Compression Screw (Key No. 4) in the top of the Shaft (Key No. 27) and remove it.
6. Remove the Rotor Compression Washer, Bearing Journal, and Discharge Shaft Spacer (Key Nos. 5,6, and 7) from the Shaft.
7. Tap the remaining Bowls (Key No. 9) with a rubber mallet to loosen them. Slide the Bowls, Impellers, and Stage Spacers (Key Nos. 8, 9 and 10) off the Shaft.
8. When you get to the bottom stage, remove the Stainless Washer, Fiber Washer, Thrust Washer, Distance Sleeve, Thrust Spacer, Impeller, First Stage Adapter, and Inlet Shaft Spacer from the Shaft (Key Nos. 12, 13, 14, 11, 15, 8, 20, and 19).
9. Finally, remove the coupling from the Pump Shaft.

ASSEMBLY

Please refer to the exploded view on Page 14 for Key No. references.

1. Clean and straighten the Pump Shaft (Key No. 27) until TIR is 50 to 100 microns (.002" to .004").
2. Slide the Coupling (Key No. 28) onto the Pump Shaft until the end of the shaft aligns with the end of the hex portion of the coupling. Lock the Coupling to the Pump Shaft with two Allen Screws (Key No. 29).
3. Install the Shaft in the Suction Bracket.
4. Bolt the Suction Bracket and shaft onto the Assembly Fixture (See Figure 7 for Fixture specifications). Make sure that the Shaft Assembly is correctly aligned and is down solidly on the Fixture.
5. Install the First Stage Adapter (Key No. 20) on the Suction Bracket.
6. Slide the Inlet Shaft Spacer (Key No. 19) down over the Shaft and seat it on the Coupling.
7. Slide an Impeller (Key No. 8) over the Shaft until it rests on the Inlet Shaft Spacer. Follow it with the Thrust Shaft Spacer, Thrust Washer, Distance Sleeve, Fiber Washer, and Stainless Washer (Key Nos. 15, 14, 11, 13, and 12), in that order.
8. Slide the first stage Bowl (Key No. 9) down over the Shaft and seat it on the Suction Adapter.
9. Check the axial clearance of the pump shaft (2.5 to 3 mm or 3/32 to 1/8").
10. Slide an Impeller (Key No. 8) over the Shaft until it rests on the Distance Sleeve. Follow it with a Stage Spacer (Key No. 10).
11. Slide the next Bowl over the Shaft and seat it by gently tapping it with a rubber mallet.
12. Slide an Impeller over the Shaft until it rests on the Stage Spacer. Follow it with another Stage Spacer.

13. Repeat steps 8, 10, 11 and 12, until you have installed all the intermediate stages. You do not need to repeat the axial clearance check at every stage.
14. Slide the last Impeller over the Shaft until it rests on the Stage Spacer. Follow it with the Discharge Shaft Spacer and the Bearing Journal (Key Nos. 7 and 6) .
15. Put the Rotor Compression Washer (Key No. 5) on the Discharge Spacer and lock it with the Rotor Compression Capscrew (Key No. 4).
NOTE: Use Loctite Threadlocker® on the capscrew threads.
16. Slide the Top Bowl over the shaft and seat it.
17. Install the Check Valve Poppet on top of the last Bowl.
18. Install the Discharge (Key No. 1) on the Top Bowl and seat the assembly by gently tapping it with a rubber mallet. Be sure that the strap slots in the discharge are clean.
19. Hook the four Straps (Key No. 21) into the Discharge and loosely fasten them to the Suction Bracket Assembly with Lock Washers (Key No. 17), Hex Head Bolts (Key No. 18), and Strap Nuts (Key No. 16).
20. Tighten the four Straps evenly to 45 ft.-lbs. torque. Be sure that the Straps seat completely in the discharge.
21. Check the axial clearance of the pump shaft (2.5 to 3 mm. or 3/32 to 1/8").
22. Check for free rotation of the pump stack.
23. Install the Suction Strainer (Key No. 24).
24. Install the Cable Guard Clamps and Cable Guard (Key Nos. 22 and 23) on the pump.
25. Remove the pump from the fixture, install the Coupling Screen (Key No. 26), and mount the pump on the motor.
The pump is ready for installation.

PREVENTIVE MAINTENANCE

To avoid major repairs, make the checks listed below every 4 to 6 months.

TEST	RESULT SHOULD BE	POSSIBLE INDICATIONS
1. Measure and record the standing water level (from top of well casing).	1. Reference number.	1. To aid in monitoring pump performance.
2. Measure electrical resistance between motor leads and well casing with motor cold.	2. See motor manual.	2. See motor manual.
3. Check pump flow capacity (gallons per minute).	3. At least 90% of readings at installation.	3. Lower readings may indicate pump needs repair.
4. Check pump discharge pressure (PSI) at operating conditions.	4. At least 90% of readings at installation.	4. Lower reading indicates pump wear, increased friction losses, or change in standing water level in well.
5. Check drawdown level (in feet) from standing water level.	5. High enough so that pump does not break suction.	5. Cavitation can damage pump; increased drawdown may indicate reduced well flow.
6. Measure voltage across motor leads while pump is operating.	6. Within $\pm 10\%$ of rated voltage.	6. If voltage is more than 110% or less than 90% of rated voltage, consult power company.

TROUBLESHOOTING

⚠ WARNING Hazardous voltage. Can shock, burn, or kill. When troubleshooting or servicing pump, use all normal precautions for the voltages involved.

1. Disconnect power unless required for testing.
2. Have electrical testing done by a qualified electrician.
3. Most problems occur above ground. Remove pump from well only as a last resort.

PROBLEM	POSSIBLE CAUSE	REMEDY
Fuses blow or overload circuit breaker trips when motor starts.	<ol style="list-style-type: none"> 1. Pump sandlocked. 2. Low or high voltage. 3. Cable damaged or shorted. 4. Pump forced into crooked well. 	<ol style="list-style-type: none"> 1. a) Check motor winding resistance - see "Circuit (Winding) Resistance", Page 6. b) If motor is not shorted, turn on current and rap discharge pipe sharply to loosen sand. c) Pull pump and clean. 2. Check line voltage (see Page 4). If high or low, contact power company. 3. Check pump cable for ground (see Page 6). 4. Forcing pump into a crooked hole will cause misalignment of pump and motor. Consult well driller.
Fuses blow or overload trips while motor is running.	<ol style="list-style-type: none"> 1. Low or high voltage. 2. Water contains abrasives. 3. Motor or cable shorted and/or grounded. 	<ol style="list-style-type: none"> 1. Check voltage on service lines (see Page 4). 2. If water contains excessive sand, remove pump and clean sand out of well. 3. See "Circuit (Winding) Resistance Test" and "Ground Check", Page 6.
Motor does not start but does not blow fuses or trip circuit breaker.	<ol style="list-style-type: none"> 1. Fuses blown or circuit breaker tripped. 2. Voltage does not reach terminals. 3. Loose wire in control box. 4. Defective magnetic controller coil. 	<ol style="list-style-type: none"> 1. Reset circuit breakers or replace fuses. 2. 3-Phase: Check voltage at controller between wire pairs: L1 – L3, L3 – L2, L2 – L1. Single Phase: Check voltage between L1 and L2 on box terminal strip. 3. Check and tighten all wires. 4. Check starter and coil.
Pump does not shut off.	<ol style="list-style-type: none"> 1. Cable leads improperly connected. 	<ol style="list-style-type: none"> 1. Check wiring diagram on box cover for correct connections.
Motor runs, but delivers little or no water.	<ol style="list-style-type: none"> 1. Horizontal line check valve installed backwards. 2. Motor running backwards (3-Phase only). 3. Pump gaslocked. 4. Water level in well has dropped. 5. Leak in discharge pipe. 6. Coupling between motor shaft and pump shaft broken. 7. Pump parts worn from abrasives. 8. Intake screen clogged. 9. Pump set below recommended depth. 10. Discharge pipe friction reduces output. 	<ol style="list-style-type: none"> 1. Reinstall correctly. 2. Reconnect motor for proper rotation (see Page 3). 3. Start and stop pump several times allowing one minute between stops and starts. 4. a) Restrict pump flow to equal well production. b) Install liquid level control. c) Reset pump lower in well. 5. Raise pipe until leak is found. 6. Remove pump from well and check coupling. If broken, call Berkeley Pumps. 7. a) Check pump shut-off pressure. Pressure should be at least 90% of pressure at installation. b) Call Berkeley Pumps. 8. Remove pump from well and clean screen. 9. a) Reduce pressure switch setting until pump will shut off. b) Install pump producing higher pressure. 10. Install larger pipe or pump producing higher pressure.

Repair Parts List

6TS Series - Radial Flow
Submersible
Turbine Pumps

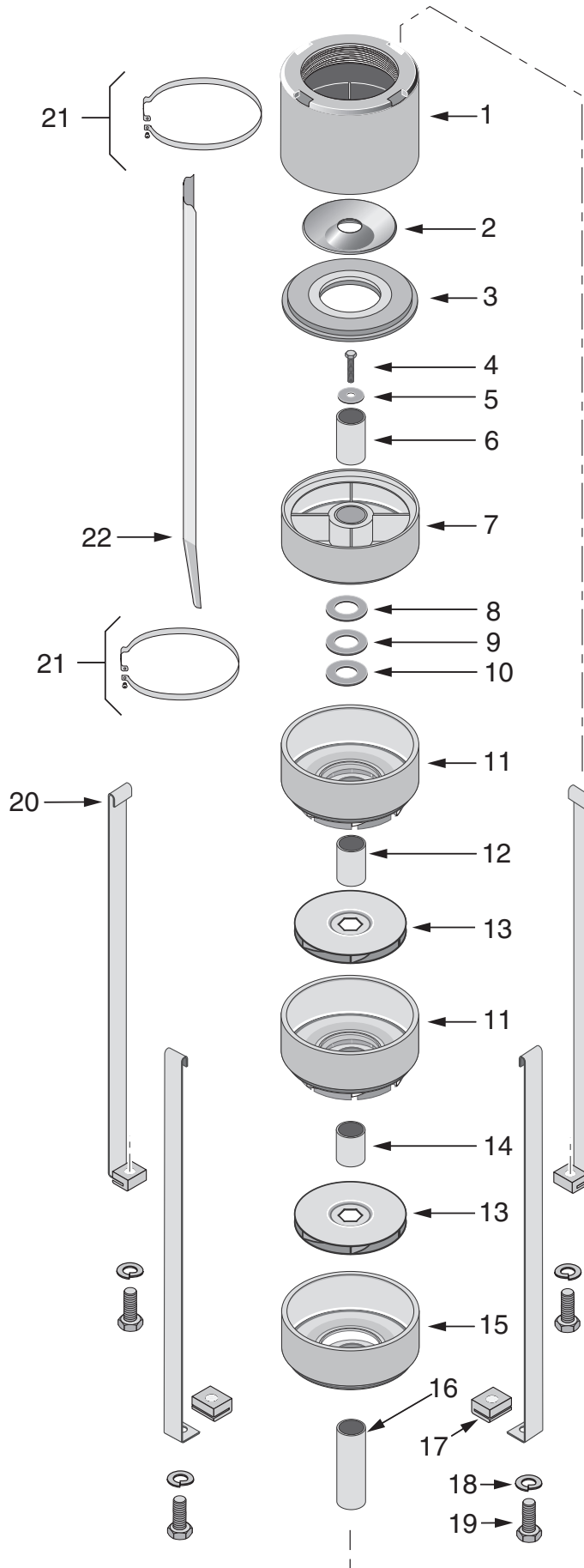
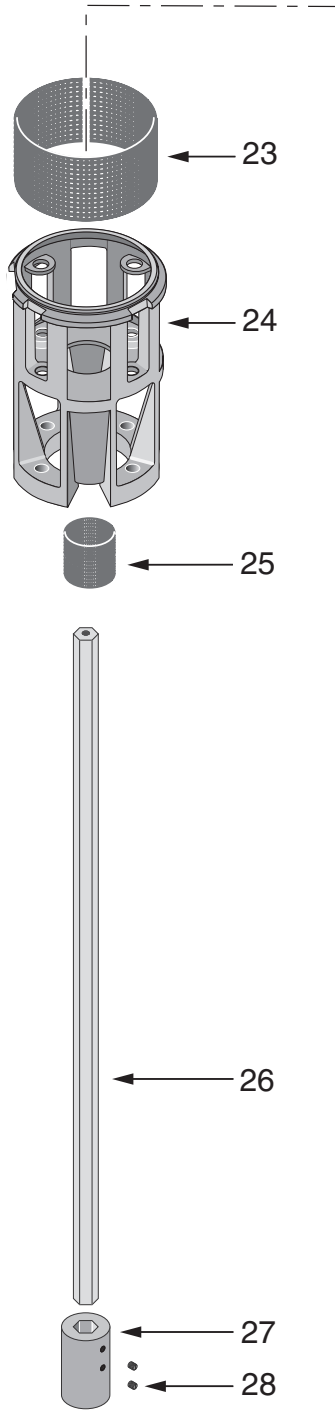

Repair Parts List
6TS Series - Radial Flow
Submersible Turbine Pumps

Key No.	Part Description	Qty.
1	Discharge	1
2	Check Valve Poppet	1
3	Check Valve Flange	1
4	Stack Compression Capscrew	1
5	Stack Compression Washer	1
6	Bearing Journal	1
7	Bearing Housing Assembly	1
8	Stainless Washer	1
9	Fiber Washer	1
10	Thrust Washer	1
11	Bowl w/Diffuser	*
12	Discharge Shaft Spacer	1
13	Impeller	*
14	Stage Spacer	*
15	First Stage Bowl w/o Diffuser	1
16	Inlet Shaft Spacer	1
17	Strap Nut	4
18	Lock Washer	4
19	Strap Capscrew	4
20	Strap	4
21	Cable Guard Bracket	2
22	Cable Guard	1
23	Suction Screen	1
24	Suction Bracket	1
25	Coupling Guard	1
26	Shaft	1
27	Coupling	1
28	Coupling Set Screws	2

* Quantity determined by number of stages.

Repair Parts List

6TS Series - Mixed Flow
Submersible
Turbine Pumps

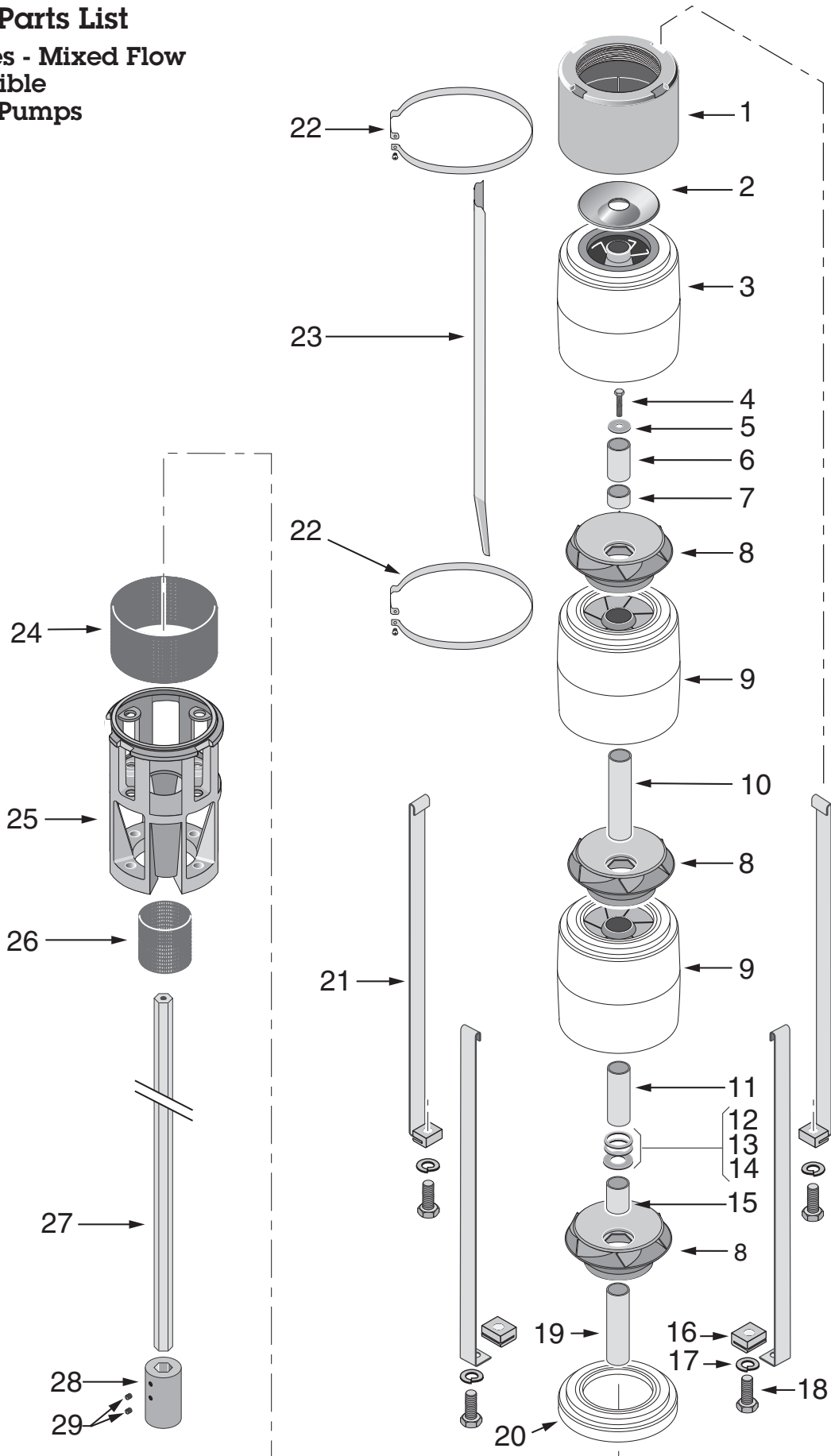

Repair Parts List
6TS Series - Mixed Flow
Submersible Turbine Pumps

Key No.	Part Description	Qty.
1	Discharge	1
2	Check Valve Poppet	1
3	Top Bowl	1
4	Stack Compression Capscrew	1
5	Stack Compression Washer	1
6	Bearing Journal	1
7	Discharge Shaft Spacer	1
8	Impeller	*
9	Bowl w/Diffuser	*
10	Stage Spacer	*
11	Distance Sleeve	1
12	Stainless Washer	1
13	Fiber Washer	1
14	Thrust Washer	1
15	Thrust Shaft Spacer	1
16	Strap Nut	4
17	Lock Washer	4
18	Strap Capscrew	4
19	Inlet Shaft Spacer	1
20	First Stage Adapter	1
21	Strap	4
22	Cable Guard Bracket	2
23	Cable Guard	1
24	Suction Screen	1
25	Suction Bracket	1
26	Coupling Guard	1
27	Shaft	1
28	Coupling	1
29	Coupling Set Screws	2

* Quantity determined by number of stages.

BERKELEY LIMITED WARRANTY

Berkeley/Wicor Canada Company (“Wicor”) warrants to the original consumer purchaser (“Purchaser”) of its products that they are free from defects in material or workmanship.

If within twelve (12) months from the date of installation or twenty-four (24) months from the date of manufacture any such product shall prove to be defective, it shall be repaired or replaced at Berkeley’s/Wicor’s option, subject to the terms and conditions set forth below.

General Terms and Conditions

Purchaser must pay all labor and shipping charges necessary to replace product covered by this warranty. This warranty shall not apply to products which, in the sole judgement of Berkeley/Wicor, have been subject to negligence, abuse, accident, misapplication, tampering, alteration; nor due to improper installation, operation, maintenance or storage; nor to other than normal application, use or service, including but not limited to, operational failures caused by corrosion, rust or other foreign materials in the system, or operation at pressures in excess of recommended maximums.

Requests for service under this warranty shall be made by contacting the installing Berkeley/Wicor dealer as soon as possible after the discovery of any alleged defect. Berkeley/Wicor will subsequently take corrective action as promptly as reasonably possible. No requests for service under this warranty will be accepted if received more than 30 days after the term of the warranty.

The warranty on all three phase submersible motors is void if three-leg overload protection of recommended size is not used.

This warranty sets forth Berkeley’s/Wicor’s sole obligation and purchaser’s exclusive remedy for defective products.

BERKELEY/WICOR SHALL NOT BE LIABLE FOR ANY CONSEQUENTIAL, INCIDENTAL, OR CONTINGENT DAMAGES WHATSOEVER.

THE FOREGOING WARRANTIES ARE EXCLUSIVE AND IN LIEU OF ALL OTHER EXPRESS WARRANTIES. IMPLIED WARRANTIES, INCLUDING BUT NOT LIMITED TO THE IMPLIED WARRANTIES OF MERCHANTABILITY AND FITNESS FOR A PARTICULAR PURPOSE, SHALL NOT EXTEND BEYOND THE DURATION OF THE APPLICABLE EXPRESS WARRANTIES PROVIDED HEREIN.

Some states do not allow the exclusion or limitation of incidental or consequential damages or limitations on how long an implied warranty lasts, so the above limitations or exclusions may not apply to you. This warranty gives you specific legal rights and you may also have other rights which vary from state to state.

In the U.S.: Berkeley, 293 Wright St., Delavan, WI 53115

**In Canada: Wicor Canada Company, 1800 Courtney Park Drive East, Unit 5-7,
Mississauga, Ontario L5T 1W1**