

# SCALA

Service instructions





Original service instructions

CONTENTS

	Page
<b>1. Symbols used in this document</b>	<b>2</b>
<b>2. Identification</b>	<b>2</b>
2.1 Nameplate	2
2.2 Type key	3
<b>3. Service tools</b>	<b>4</b>
3.1 Standard tools	4
<b>4. Lubricants</b>	<b>4</b>
<b>5. Dismantling and assembly</b>	<b>5</b>
5.1 General information	5
5.2 Removing the control box cover	5
5.3 Removing the pressure tank	5
5.4 Removing the chamber stack	7
5.5 Removing the shaft seal	7
<b>6. Fitting the shaft seal</b>	<b>7</b>
6.1 Fitting the chamber stack	8
6.2 Fitting the pressure tank	8
6.3 Fitting the control box cover	9
<b>7. Fault finding the product</b>	<b>10</b>
7.1 Grundfos Eye operating indications	10
7.2 Fault resetting	10
7.3 Fault finding chart	11
<b>8. Exploded view</b>	<b>13</b>

1. Symbols used in this document

- DANGER**  
 Indicates a hazardous situation which, if not avoided, will result in death or serious personal injury.
- WARNING**  
 Indicates a hazardous situation which, if not avoided, could result in death or serious personal injury.
- CAUTION**  
 Indicates a hazardous situation which, if not avoided, could result in minor or moderate personal injury.
- !**  
 If these instructions are not observed, it may result in malfunction or damage to the equipment.

The text accompanying the three hazard symbols DANGER, WARNING and CAUTION is structured in the following way:

- SIGNAL WORD**  
**Description of hazard**  
 Consequence of ignoring the warning.  
 - Action to avoid the hazard.

2. Identification

2.1 Nameplate

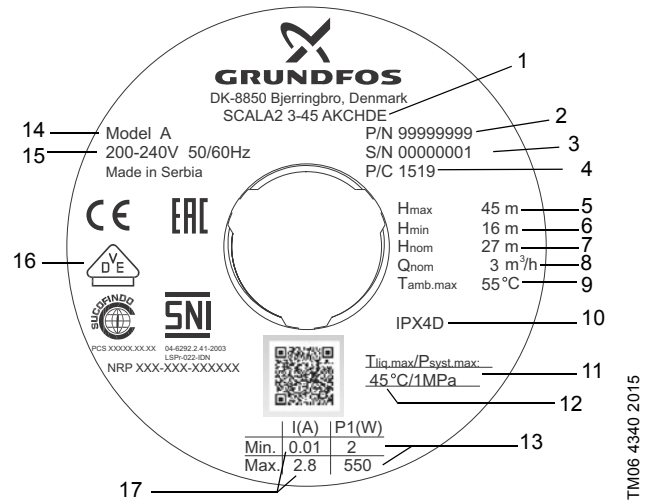

Fig. 1 Example of nameplate

Pos.	Description
1	Type designation
2	Product number
3	Serial number
4	Production code, year and week
5	Maximum head
6	Minimum head
7	Rated head
8	Rated flow rate
9	Maximum ambient temperature
10	IP class
11	Maximum operation pressure
12	Maximum liquid temperature
13	Minimum and maximum rated power
14	Model
15	Voltage and frequency
16	Approvals
17	Minimum and maximum rated current

TM06 4340 2015

## 2.2 Type key

	SCALA2	3	-45	A	K	C	H	D	E
<b>Type range</b>									
SCALA1 Economy									
SCALA2 Comfort									
<b>Rated flow rate</b> [m <sup>3</sup> /h]									
<b>Maximum head</b> [m]									
<b>Material code</b>									
A: Standard									
<b>Supply voltage</b>									
K: 1 x 200-240 V, 50/60 Hz									
M: 1 x 208-230 V, 60 Hz									
V: 1 x 115 V, 60 Hz									
W: 1 x 100-115 V, 50/60 Hz									
<b>Motor</b>									
C: High-efficiency motor with frequency converter									
<b>Power supply cable and plug</b>									
A: Cable with plug, IEC type I, AS/NZS3112, 2 m									
B: Cable with plug, IEC type B, NEMA 5-15P, 6 ft									
C: Cable with plug, IEC, type E&F, CEE7/7, 2 m									
D: Cable without plug, 2 m									
G: Cable with plug, IEC type G, BS1363, 2 m									
H: Cable with plug, IEC type I, IRAM 2073, 2 m									
J: Cable with plug, NEMA 6-15P, 6 ft									
<b>Controller</b>									
D: Integrated frequency converter									
<b>Thread</b>									
A: R 1" EN 1.4308									
C: NPT 1" EN 1.4308									
E: R 1" composite material									
F: NPT 1" composite material									

### 3. Service tools

#### 3.1 Standard tools

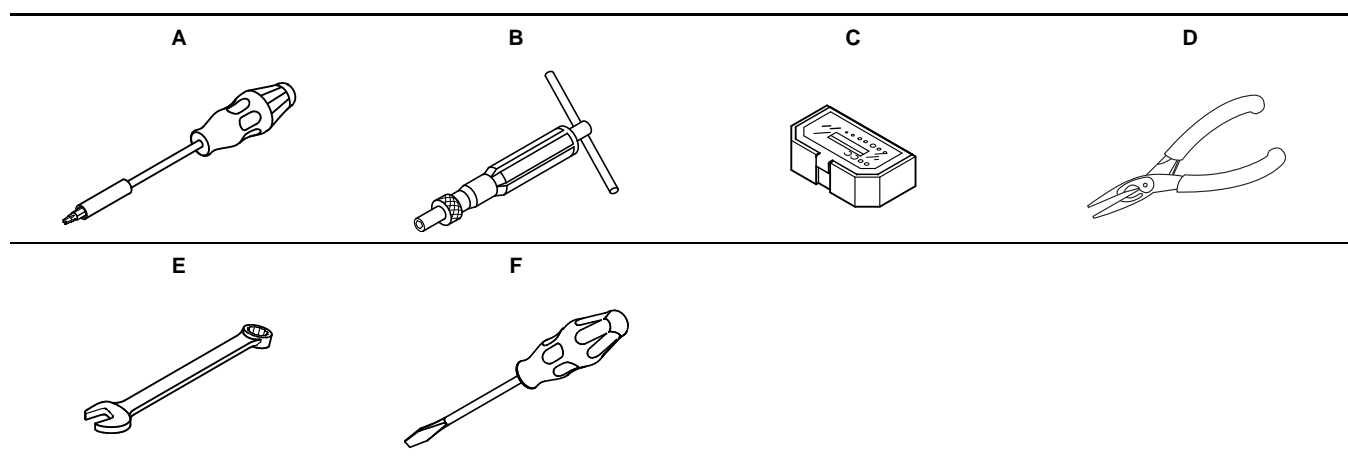

#### Standard tools

Pos.	Range	Designation	Description	Part number
A	All	Torx screwdriver	-	-
B	All	Torque screwdriver	1-6 Nm	SV0438
C	All	Bits kit	5 mm hexagon	SV2010
D	All	Needle-nose pliers	-	-
E	All	Ring/open-end spanner	M89 - 13 mm	SV0055
F		Flat-blade screwdriver	-	-

### 4. Lubricants

If nothing else is specified, all O-rings are to be lubricated with Rocol Sapphire Aqua-Sil.

Product	Product number
Rocol Sapphire Aqua-Sil, 1 kg	RM2924
Castrol Optimol Paste White T, 0.5 kg	V6001176

## 5. Dismantling and assembly

### 5.1 General information

#### DANGER

#### Electric shock

Death or serious personal injury

- Before starting any work on the product, make sure that the power supply has been switched off and that it cannot be accidentally switched on.



#### 5.1.1 Before dismantling

- Disconnect the power supply to the motor.
- Remove the power cable in accordance with local regulations.
- Open a tap to release the pressure in the pipe system.
- Gradually loosen the non-return valve (65a) to release the pressure in the pump.
- Remove the drain plug (7) to drain the pump.

#### 5.1.2 Before assembly

- Always replace gaskets and O-rings when you overhaul the pump.
- Clean and check all parts.
- Replace defective parts.

### 5.2 Removing the control box cover



Always use an antistatic service kit when handling electronic components. This will prevent static electricity from damaging components.

1. Remove the six pan-head torx screws in the cover (164a).
2. Carefully lift off the control box cover and disconnect the HMI plug.

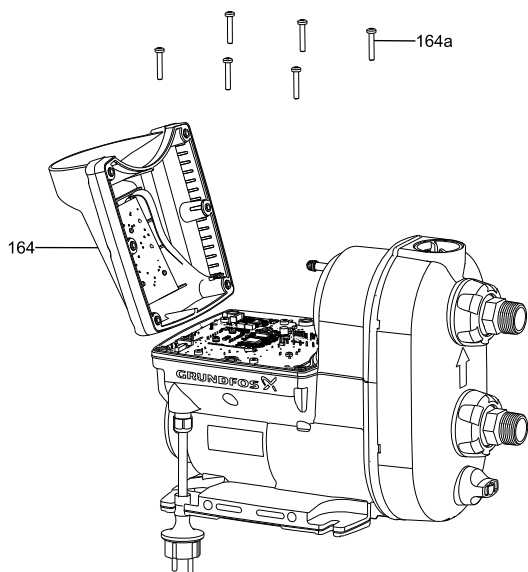

Fig. 2 Removing the control box cover

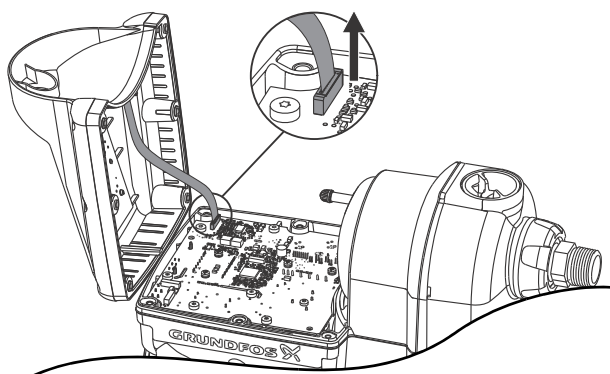

Fig. 3 Disconnecting the HMI plug

### 5.3 Removing the pressure tank

1. Slowly unscrew the non-return valve (65a) to release any pressure in the pump.
2. Remove the drain plug (7).
3. Remove the union nut (100) by turning it counterclockwise by hand.
4. Pull out the nipples (100a).
5. Pull out the non-return valve (65) from the inlet.
6. Remove the O-rings from the nipples, valves and plugs.
7. Carefully remove the pump cover (403) using a flat-blade screwdriver.



To avoid damage to the connection part, insert the flat-blade screwdriver in the top slots and pop the cover loose by moving the screwdriver handle towards the pump body. See fig. 4.

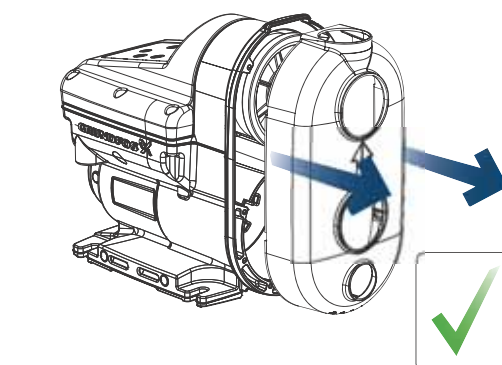
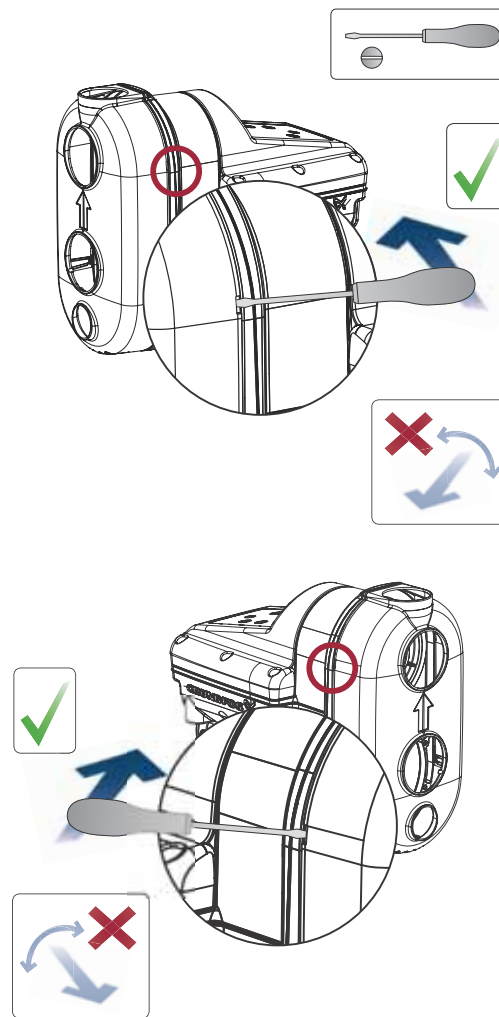
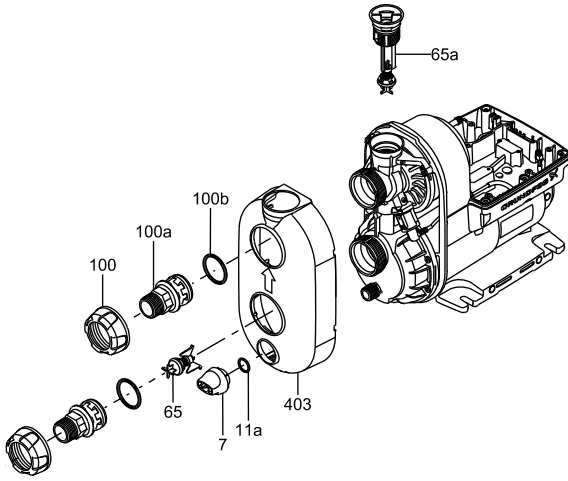

Fig. 4 Removing the cover

TM06 5151 3915

TM06 5282 4315

TM06 7639 3816 - TM0 67640 3816 - TM06 7641 3816



**Fig. 5** Removing the nipples and the cover

8. Remove the retaining clip (175) for the sensor and remove the sensor (174a).
9. Remove the sensor (174a).

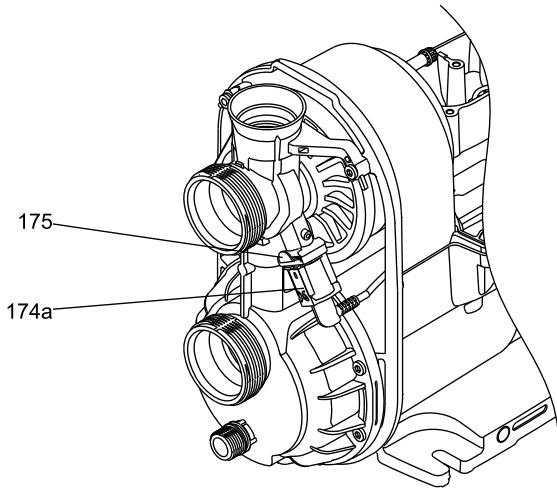
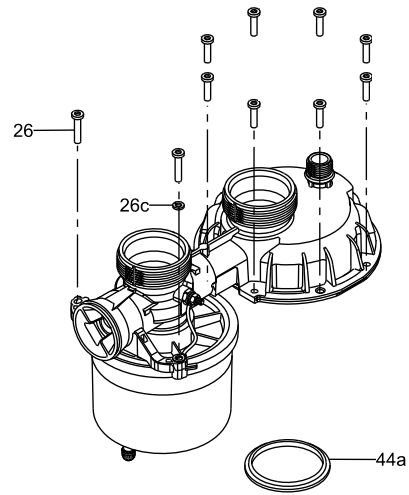

**Fig. 6** Sensor and retaining clip

TM06 5150 3915

TM06 5152 3915

10. Remove the screws (26) that hold the connection part. Note that one of the screws holds the earth connection bracket (173c) and washer.
11. Remove the connection part and the pressure tank.
12. Remove the seal ring (44a).



**Fig. 7** Removing the connection part

13. Remove the self-priming valve (10) and O-ring (37).

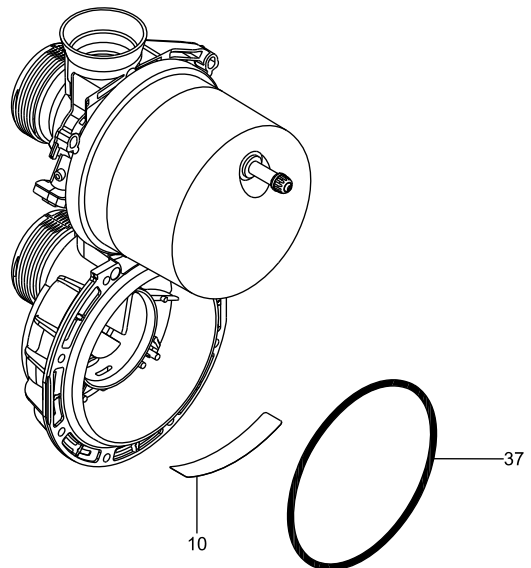
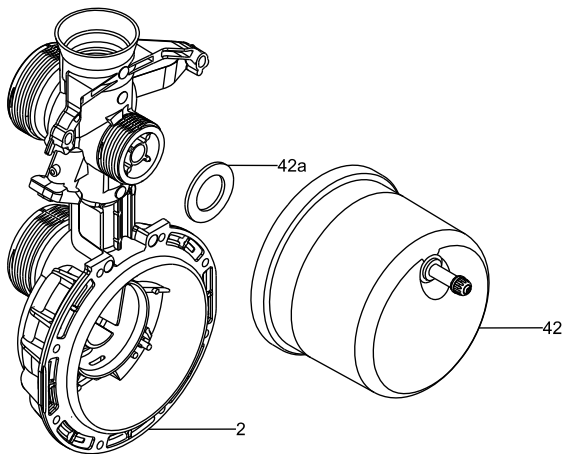

**Fig. 8** Self-priming valve and O-ring for connections part

TM06 5149 3915

TM06 5153 3915

14. Unscrew the pressure tank (42) counterclockwise and remove the gasket for the tank (42a).



TM06 5154 3915

Fig. 9 Removing the pressure tank

### 5.4 Removing the chamber stack

1. Remove the plug (169) on nameplate to access the shaft end.
2. Remove the locking nut (67) and the washer (66). Hold the shaft with a screwdriver in the shaft end.

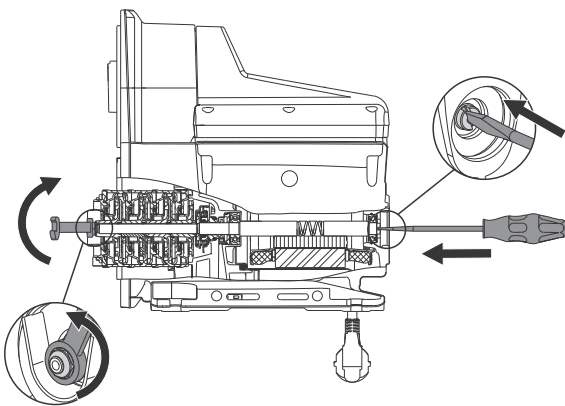
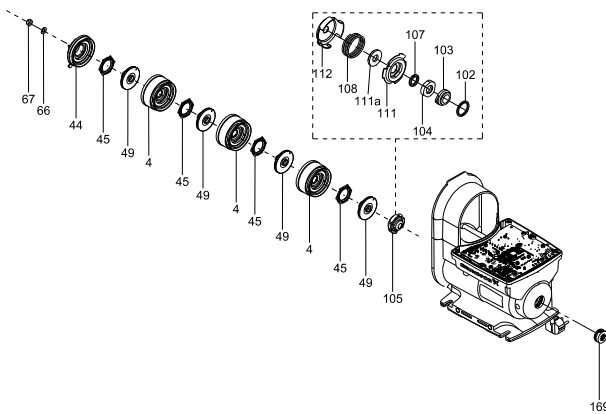

Fig. 10 Loosening the locking nut for the chamber stack

3. Remove the chamber stack.



TM06 5170 3915

Fig. 11 Chamber stack and shaft seal

### 5.5 Removing the shaft seal

1. Remove the rotating shaft seal face (104).
2. Remove the stationary seat (103) using a needle-nose pliers.



TM06 5169 3915

Fig. 12 Removing the stationary shaft seal

### 6. Fitting the shaft seal

1. Fit the stationary seat (103) with the O-ring (102) against the pump housing.

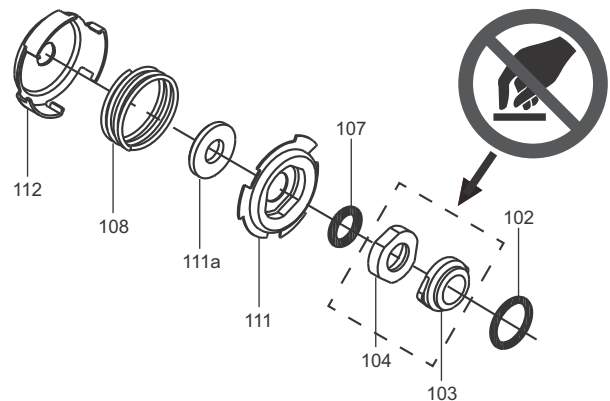

TM06 5341 4415

Fig. 13 Shaft seal complete



Do not touch the ceramic faces of the shaft seal.

2. Fit the rotating shaft seal face (104).

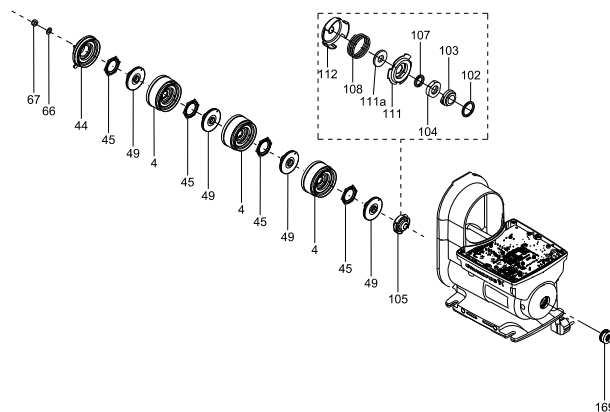

TM06 5170 3915

Fig. 14 Fitting the shaft seal and the chamber stack

### 6.1 Fitting the chamber stack

1. Fit the impellers (49), the seal (45) and the chambers (4). Fit the seal ring (44a) last.
2. Fit the washer (66) and the locking nut (67) and tighten it to 5 Nm. Hold the shaft end using a screwdriver.

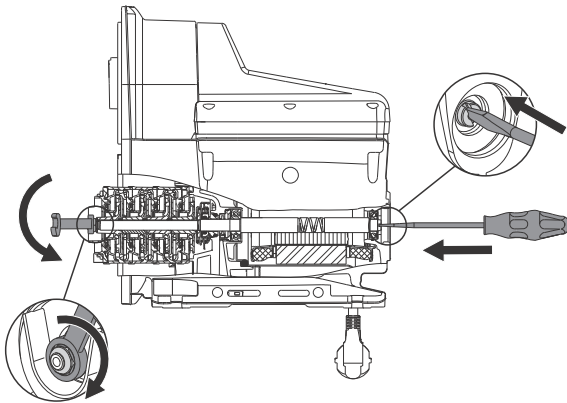

Fig. 15 Tightening the nut of the chamber stack

TM06 5158 3915

### 6.2 Fitting the pressure tank

1. Fit the flat gasket (42a) and screw the pressure tank (42) on to the connection part (2) by hand.

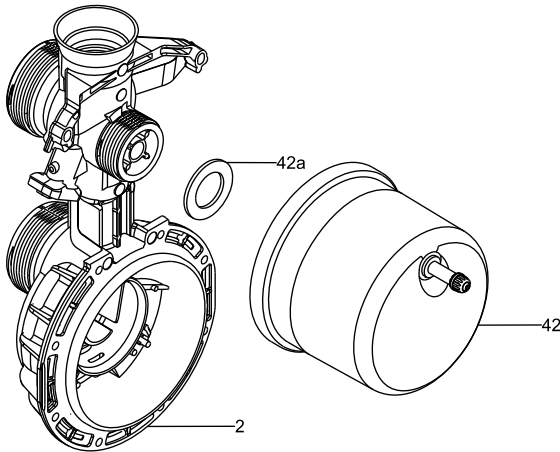

Fig. 16 Fitting the pressure tank

TM06 5154 3915

2. Fit the self-priming valve (10) and the O-ring (37).

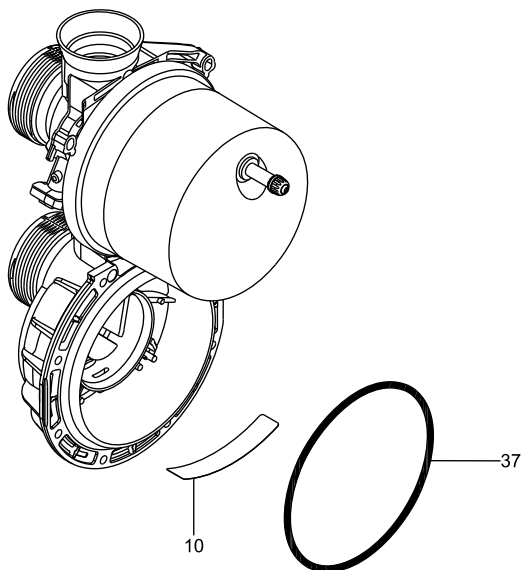

Fig. 17 Fitting the self-priming valve and the O-ring

TM06 5163 3915

3. Check that the self-priming valve is fitted correctly.

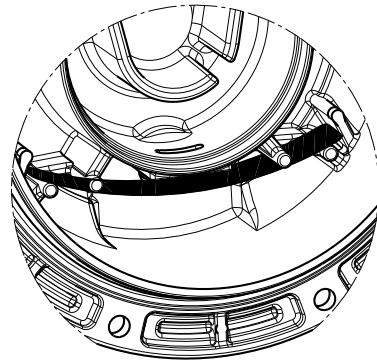

Fig. 18 Correct position of the self-priming valve

4. Fit the connection part to the pump housing. Note that one screw holds the earth connection bracket and the washer.
5. Cross-tighten the screws according to table below.

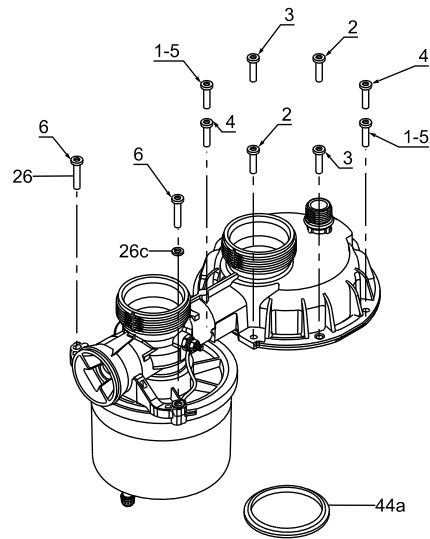

Fig. 19 Fitting the connection part

TM06 5149 3915

Sequence	Torque [Nm]
1	
2	
3	
4	3 ± 0.5
5	
6	



- Fit the sensor (174a) and fasten it by means of the retaining clip (175).



Check that the rubber sensor pocket is seated correctly.

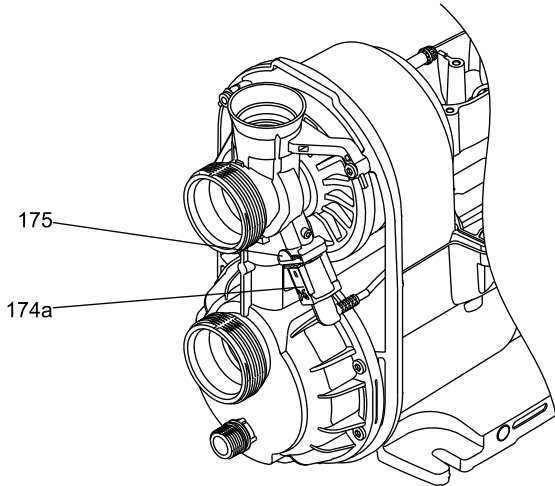

TM06 5152 3915

**Fig. 20** Sensor and retaining clip

- Press the pump cover back onto the pump housing.
- Fit new O-rings to the valves, nipples and plugs.
- Fit the inlet valve in the connection part.
- Press the nipples into the connection part, fit the union nuts and tighten them by hand.
- Fit the drain plug (7) and the non-return valve (65a).



Always tighten plastic nuts and plugs by hand so as not to break the material.

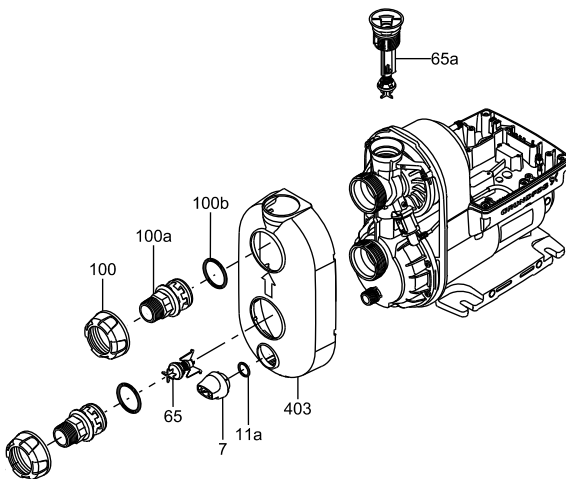

TM06 5150 3915

**Fig. 21** Fitting the nipples and the cover

### 6.3 Fitting the control box cover

- Connect the HMI plug and place the control box cover on the pump.

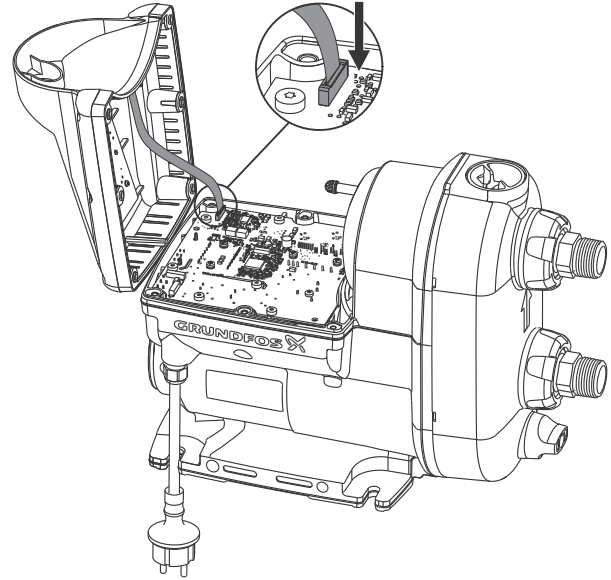

TM06 5150 3915

**Fig. 22** Connecting the HMI plug

- Cross-tighten the six pan-head torx screws according to the table below.

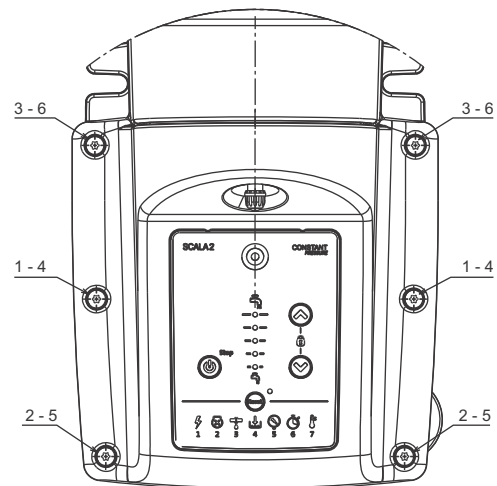







TM06 4959 0516

**Fig. 23** Tightening sequence

Sequence	Torque [Nm]
1	
2	
3	
4	2 ± 0.25
5	
6	

## 7. Fault finding the product

### 7.1 Grundfos Eye operating indications

Grundfos Eye	Indication	Description
	No lights are on.	The power is off. The pump is not running.
	Two opposite green indicator lights running in the direction of rotation of the pump.	The power is on. The pump is running.
	Two opposite green indicator lights at a 45 ° angle is the icon used throughout this document for pump running.	The power is on. The pump is running.
	Two opposite green indicator lights permanently on.	The power is on. The pump is not running.
	Two opposite red indicator lights flashing simultaneously.	Alarm. The pump has stopped.
	Two opposite red indicator lights is the icon used throughout this document for pump stopped.	Alarm. The pump has stopped.

### 7.2 Fault resetting

You can reset a fault indication in one of the following ways:

- When you have eliminated the fault cause, reset the pump manually by pressing the  button. The pump then reverts to normal duty.
- If the fault disappears by itself, the pump attempts to reset automatically and the fault indication disappears if automatic reset is successful and provided that you have enabled "Auto reset" in the service menu.

## 7.3 Fault finding chart

**DANGER****Electric shock**

Death or serious personal injury

- Before starting any work on the product, make sure that the power supply has been switched off and that it cannot be accidentally switched on.

Fault	Grundfos Eye	Indicator light	Automatic reset	Cause	Remedy
1. The pump is not running.		-	-	Power supply failure.	Switch on the power supply. Check the cables and cable connections for defects and loose connections and check for blown fuses in the electrical installation.
			Yes	The power supply is out of the prescribed voltage range.	Check the power supply and the pump nameplate. Reestablish the power supply within the prescribed voltage range.
			No	The shaft seal has seized up.	Remove the end cover plug and deblock the shaft seal by turning the shaft by means of a screwdriver.
			No	The pump is blocked by impurities.	Contact Grundfos Service if the problem persists.
			Yes	Dry running.	Check the water source, and prime the pump.
			No	The maximum runtime has been exceeded.	Check the installation for leakage and reset the alarm.
			No	The internal non-return valve is defective or blocked in completely or partly open position.	Clean, repair or replace the non-return valve.
2. The pump is running.			-	Leakage from the pipes, or the non-return valve is not properly closed due to impurities.	Check and repair the pipes, or clean, repair or replace the non-return valve.
			-	Small continuous consumption.	Check the taps and reconsider the usage pattern (ice machines, water evaporators for air-conditioning, etc.).
			-	The temperature is below the freezing point.	Consider protecting the pump and the installation against frost.
3. Pump performance is insufficient.		-	-	The pump inlet pressure is too low.	Check the inlet conditions of the pump.
		-	-	The pump is undersized.	Replace the pump with a bigger pump.
		-	-	The inlet pipe, the inlet strainer or the pump is partly blocked by impurities.	Clean the inlet pipe or the pump.
		-	-	Leakage in the inlet pipe.	Repair the inlet pipe.
		-	-	Air in the inlet pipe or the pump.	Prime the inlet pipe and the pump. Check the inlet conditions of the pump.
		-	-	The required outlet pressure is too low for the installation.	Increase the pressure setting (arrow up).
			Yes	The maximum temperature has been exceeded and the pump is running at reduced performance.	Check the cooling conditions. Protect the pump against direct sunlight or any nearby heat sources.

Fault	Grundfos Eye	Indicator light	Automatic reset	Cause	Remedy
4. System overpressure.			Yes	The setpoint has been set too high. The difference between the outlet pressure and the inlet pressure must not exceed 4 bar (58 psi). Example: If the required outlet pressure is 5 bar (73 psi), the minimum inlet pressure must be 1 bar (14.5 psi).	Reduce the setpoint to 4 bar (58 psi) plus positive inlet pressure.
			Yes	The maximum pressure has been exceeded and the inlet pressure is higher than 6 bar, 0.6 MPa (85 psi)	Check the inlet conditions.
			Yes	The maximum pressure has been exceeded. Equipment elsewhere in the system causes a high pressure at the pump (e.g. water heater or defective safety equipment).	Check the installation.
5. You can reset the pump, but the pump runs only for a few seconds.			Yes	Dry running or water shortage.	Check the water source, and prime the pump.
			Yes	The inlet pipe is blocked by impurities.	Clean the inlet pipe.
			Yes	The foot or non-return valve is blocked in closed position.	Clean, repair or replace the foot or non-return valve.
			Yes	Leakage in the inlet pipe.	Repair the inlet pipe.
			Yes	Air in the inlet pipe or the pump.	Prime the inlet pipe and the pump. Check the inlet conditions of the pump.
6. You can reset the pump, but the pump starts repeatedly, immediately after stopping.			No	The internal non-return valve is defective or blocked in completely or partly open position.	Clean, repair or replace the non-return valve.
			No	The tank precharge pressure is not correct.	Adjust the tank precharge pressure to 70 % of the required outlet pressure.

8. Exploded view

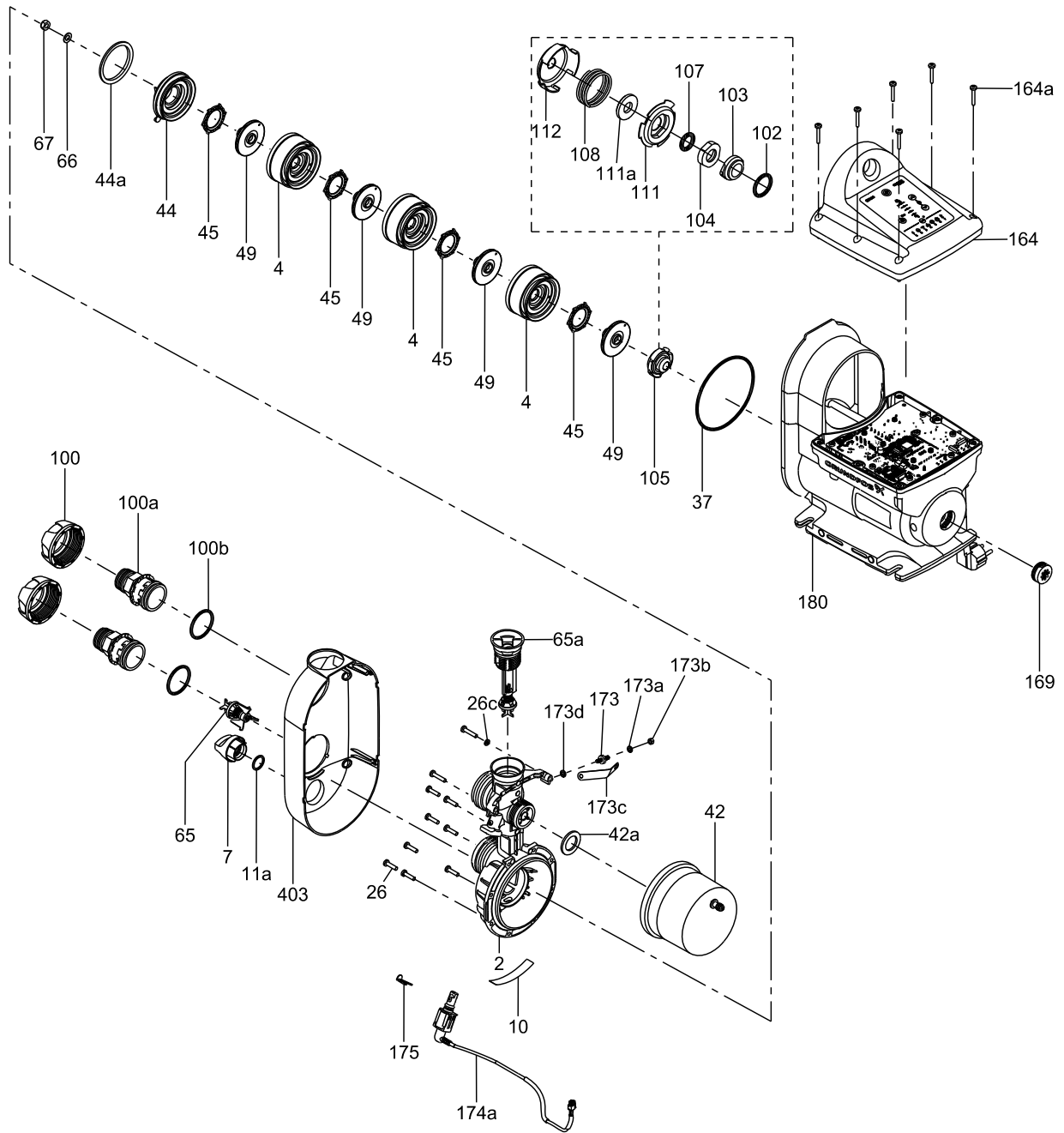

Fig. 24 Exploded view

TM06 4966 3615

## Position number list

Pos.	Description
2	Connection part
4	Chamber
7	Drain plug
10	Self-priming valve
11a	O-ring
26	Screw
26c	Lock washer
37	O-ring
42	Tank complete
42a	Flat gasket
44	Inlet part
44a	Seal ring
45	Seal
49	Impeller
65	Non-return valve, inlet
65a	Non-return valve, outlet
66	Washer
67	Locking nut
100	Union nut
100a	Nipple
100b	O-ring
102	O-ring
103	Stationary seat
104	Rotating seal face
105	Shaft seal complete
107	O-ring
108	Spring
111	Seal driver
111a	Washer
112	Seal driver
164	Control box cover
164a	Pan-head torx screw
169	Plug
173	Double-end stud bolt
173a	Lock washer
173b	Hexagon nut
173c	Earth connection bracket
173d	O-ring
174a	Sensor complete
175	Retaining clip
180	Combined pump and stator housing
403	Pump cover

---

Subject to alterations.

**Argentina**

Bombas GRUNDFOS de Argentina S.A.  
Ruta Panamericana km. 37.500 Centro  
Industrial Garin  
1619 Garin Pcia. de B.A.  
Phone: +54-3327 414 444  
Telefax: +54-3327 45 3190

**Australia**

GRUNDFOS Pumps Pty. Ltd.  
P.O. Box 2040  
Regency Park  
South Australia 5942  
Phone: +61-8-8461-4611  
Telefax: +61-8-8340 0155

**Austria**

GRUNDFOS Pumpen Vertrieb Ges.m.b.H.  
Grundfosstraße 2  
A-5082 Grödig/Salzburg  
Tel.: +43-6246-883-0  
Telefax: +43-6246-883-30

**Belgium**

N.V. GRUNDFOS Bellux S.A.  
Boomssesteenweg 81-83  
B-2630 Aartselaar  
Tél.: +32-3-870 7300  
Télécopie: +32-3-870 7301

**Belarus**

Представительство ГРУНДФОС в  
Минске  
220125, Минск  
ул. Шафарнянская, 11, оф. 56, БЦ  
«Порт»  
Тел.: +7 (375 17) 286 39 72/73  
Факс: +7 (375 17) 286 39 71  
E-mail: minsk@grundfos.com

**Bosnia and Herzegovina**

GRUNDFOS Sarajevo  
Zmaja od Bosne 7-7A,  
BH-71000 Sarajevo  
Phone: +387 33 592 480  
Telefax: +387 33 590 465  
www.ba.grundfos.com  
e-mail: grundfos@bih.net.ba

**Brazil**

BOMBAS GRUNDFOS DO BRASIL  
Av. Humberto de Alencar Castelo Branco,  
630  
CEP 09850 - 300  
São Bernardo do Campo - SP  
Phone: +55-11 4393 5533  
Telefax: +55-11 4343 5015

**Bulgaria**

Grundfos Bulgaria EOOD  
Slatina District  
Iztochna Tangenta street no. 100  
BG - 1592 Sofia  
Tel. +359 2 49 22 200  
Fax. +359 2 49 22 201  
email: bulgaria@grundfos.bg

**Canada**

GRUNDFOS Canada Inc.  
2941 Brighton Road  
Oakville, Ontario  
L6H 6C9  
Phone: +1-905 829 9533  
Telefax: +1-905 829 9512

**China**

GRUNDFOS Pumps (Shanghai) Co. Ltd.  
10F The Hub, No. 33 Suhong Road  
Minhang District  
Shanghai 201106  
PRC  
Phone: +86 21 612 252 22  
Telefax: +86 21 612 253 33

**Croatia**

GRUNDFOS CROATIA d.o.o.  
Buzinski prilaz 38, Buzin  
HR-10010 Zagreb  
Phone: +385 1 6595 400  
Telefax: +385 1 6595 499  
www.hr.grundfos.com

**GRUNDFOS Sales Czechia and Slovakia s.r.o.**

Čajkovského 21  
779 00 Olomouc  
Phone: +420-585-716 111

**Denmark**

GRUNDFOS DK A/S  
Martin Bachs Vej 3  
DK-8850 Bjerringbro  
Tlf.: +45-87 50 50 50  
Telefax: +45-87 50 51 51  
E-mail: info\_GDK@grundfos.com  
www.grundfos.com/DK

**Estonia**

GRUNDFOS Pumps Eesti OÜ  
Peterburi tee 92G  
11415 Tallinn  
Tel: + 372 606 1690  
Fax: + 372 606 1691

**Finland**

OY GRUNDFOS Pumput AB  
Trukkikuja 1  
FI-01360 Vantaa  
Phone: +358-(0) 207 889 500

**France**

Pompes GRUNDFOS Distribution S.A.  
Parc d'Activités de Chesnes  
57, rue de Malacombe  
F-38290 St. Quentin Fallavier (Lyon)  
Tél.: +33-4 74 82 15 15  
Télécopie: +33-4 74 94 10 51

**Germany**

GRUNDFOS GMBH  
Schlüterstr. 33  
40699 Erkrath  
Tel.: +49-(0) 211 929 69-0  
Telefax: +49-(0) 211 929 69-3799  
e-mail: infoservice@grundfos.de  
Service in Deutschland:  
e-mail: kundendienst@grundfos.de

**Greece**

GRUNDFOS Hellas A.E.B.E.  
20th km. Athinon-Markopoulou Av.  
P.O. Box 71  
GR-19002 Peania  
Phone: +0030-210-66 83 400  
Telefax: +0030-210-66 46 273

**Hong Kong**

GRUNDFOS Pumps (Hong Kong) Ltd.  
Unit 1, Ground floor  
Siu Wai Industrial Centre  
29-33 Wing Hong Street &  
68 King Lam Street, Cheung Sha Wan  
Kowloon  
Phone: +852-27861706 / 27861741  
Telefax: +852-27858664

**Hungary**

GRUNDFOS Hungária Kft.  
Park u. 8  
H-2045 Törökbálint,  
Phone: +36-23 511 110  
Telefax: +36-23 511 111

**India**

GRUNDFOS Pumps India Private Limited  
118 Old Mahabalipuram Road  
Thoraiakkam  
Chennai 600 096  
Phone: +91-44 2496 6800

**Indonesia**

PT. GRUNDFOS POMPA  
Graha Intirub Lt. 2 & 3  
Jln. Ciliitan Besar No.454. Makasar,  
Jakarta Timur  
ID-Jakarta 13650  
Phone: +62 21-469-51900  
Telefax: +62 21-460 6910 / 460 6901

**Ireland**

GRUNDFOS (Ireland) Ltd.  
Unit A, Merrywell Business Park  
Ballymount Road Lower  
Dublin 12  
Phone: +353-1-4089 800  
Telefax: +353-1-4089 830

**Italy**

GRUNDFOS Pompe Italia S.r.l.  
Via Gran Sasso 4  
I-20060 Truccazzano (Milano)  
Tel.: +39-02-95838112  
Telefax: +39-02-95309290 / 95838461

**Japan**

GRUNDFOS Pumps K.K.  
1-2-3, Shin-Miyakoda, Kita-ku,  
Hamamatsu  
431-2103 Japan  
Phone: +81 53 428 4760  
Telefax: +81 53 428 5005

**Korea**

GRUNDFOS Pumps Korea Ltd.  
6th Floor, Aju Building 679-5  
Yeoksam-dong, Kangnam-ku, 135-916  
Seoul, Korea  
Phone: +82-2-5317 600  
Telefax: +82-2-5633 725

**Latvia**

SIA GRUNDFOS Pumps Latvia  
Deglava biznesa centrs  
Augusta Deglava ielā 60, LV-1035, Rīga,  
Tālr.: + 371 714 9640, 7 149 641  
Fakss: + 371 914 9646

**Lithuania**

GRUNDFOS Pumps UAB  
Smolensko g. 6  
LT-03201 Vilnius  
Tel: + 370 52 395 430  
Fax: + 370 52 395 431

**Malaysia**

GRUNDFOS Pumps Sdn. Bhd.  
7 Jalan Peguam U1/25  
Glenmarie Industrial Park  
40150 Shah Alam  
Selangor  
Phone: +60-3-5569 2922  
Telefax: +60-3-5569 2866

**Mexico**

Bombas GRUNDFOS de México S.A. de  
C.V.  
Boulevard TLC No. 15  
Parque Industrial Stiva Aeropuerto  
Apodaca, N.L. 66600  
Phone: +52-81-8144 4000  
Telefax: +52-81-8144 4010

**Netherlands**

GRUNDFOS Netherlands  
Veluwezoom 35  
1326 AE Almere  
Postbus 22015  
1302 CA ALMERE  
Tel.: +31-88-478 6336  
Telefax: +31-88-478 6332  
E-mail: info\_gnl@grundfos.com

**New Zealand**

GRUNDFOS Pumps NZ Ltd.  
17 Beatrice Tinsley Crescent  
North Harbour Industrial Estate  
Albany, Auckland  
Phone: +64-9-415 3240  
Telefax: +64-9-415 3250

**Norway**

GRUNDFOS Pumper A/S  
Strømsveien 344  
Postboks 235, Leirdal  
N-1011 Oslo  
Tlf.: +47-22 90 47 00  
Telefax: +47-22 32 21 50

**Poland**

GRUNDFOS Pompy Sp. z o.o.  
ul. Klonowa 23  
Baranowo k. Poznania  
PL-62-081 Przeźmierowo  
Tel: (+48-61) 650 13 00  
Fax: (+48-61) 650 13 50

**Portugal**

Bombas GRUNDFOS Portugal, S.A.  
Rua Calvet de Magalhães, 241  
Apartado 1079  
P-2770-153 Paço de Arcos  
Tel.: +351-21-440 76 00  
Telefax: +351-21-440 76 90

**Romania**

GRUNDFOS Pompe România SRL  
Bd. Biruintei, nr 103  
Pantelimon county Ilfov  
Phone: +40 21 200 4100  
Telefax: +40 21 200 4101  
E-mail: romania@grundfos.ro

**Russia**

ООО Грундфос Россия  
109544, г. Москва, ул. Школьная, 39-41,  
стр. 1  
Тел. (+7) 495 564-88-00 (495) 737-30-00  
Факс (+7) 495 564 88 11  
E-mail grundfos.moscow@grundfos.com

**Serbia**

Grundfos Srbija d.o.o.  
Omladinskih brigada 90b  
11070 Novi Beograd  
Phone: +381 11 2258 740  
Telefax: +381 11 2281 769  
www.rs.grundfos.com

**Singapore**

GRUNDFOS (Singapore) Pte. Ltd.  
25 Jalan Tukang  
Singapore 619264  
Phone: +65-6681 9688  
Telefax: +65-6681 9689

**Slovakia**

GRUNDFOS s.r.o.  
Prievozska 4D  
821 09 BRATISLAVA  
Phona: +421 2 5020 1426  
sk.grundfos.com

**Slovenia**

GRUNDFOS LJUBLJANA, d.o.o.  
Leskoškova 9e, 1122 Ljubljana  
Phone: +386 (0) 1 568 06 10  
Telefax: +386 (0)1 568 06 19  
E-mail: tehnika-si@grundfos.com

**South Africa**

GRUNDFOS (PTY) LTD  
Corner Mountjoy and George Allen Roads  
Wilbart Ext. 2  
Bedfordview 2008  
Phone: (+27) 11 579 4800  
Fax: (+27) 11 455 6066  
E-mail: lsmart@grundfos.com

**Spain**

Bombas GRUNDFOS España S.A.  
Camino de la Fuentesilla, s/n  
E-28110 Algete (Madrid)  
Tel.: +34-91-848 8800  
Telefax: +34-91-628 0465

**Sweden**

GRUNDFOS AB  
Box 333 (Lunnagårdsgatan 6)  
431 24 Mölndal  
Tel.: +46 31 332 23 000  
Telefax: +46 31 331 94 60

**Switzerland**

GRUNDFOS Pumpen AG  
Bruggacherstrasse 10  
CH-8117 Fällanden/ZH  
Tel.: +41-44-806 8111  
Telefax: +41-44-806 8115

**Taiwan**

GRUNDFOS Pumps (Taiwan) Ltd.  
7 Floor, 219 Min-Chuan Road  
Taichung, Taiwan, R.O.C.  
Phone: +886-4-2305 0868  
Telefax: +886-4-2305 0878

**Thailand**

GRUNDFOS (Thailand) Ltd.  
92 Chaloeam Phrakiat Rama 9 Road,  
Dokmai, Pravej, Bangkok 10250  
Phone: +66-2-725 8999  
Telefax: +66-2-725 8998

**Turkey**

GRUNDFOS POMPA San. ve Tic. Ltd. Sti.  
Gebze Organize Sanayi Bölgesi  
Ihsan dede Caddesi,  
2. yol 200, Sokak No. 204  
41490 Gebze/ Kocaeli  
Phone: +90 - 262-679 7979  
Telefax: +90 - 262-679 7905  
E-mail: satis@grundfos.com

**Ukraine**

Бізнес Центр Європа  
Столичне шосе, 103  
м. Київ, 03131, Україна  
Телефон: (+38 044) 237 04 00  
Факс.: (+38 044) 237 04 01  
E-mail: ukraine@grundfos.com

**United Arab Emirates**

GRUNDFOS Gulf Distribution  
P.O. Box 16768  
Jebel Ali Free Zone  
Dubai  
Phone: +971 4 8815 166  
Telefax: +971 4 8815 136

**United Kingdom**

GRUNDFOS Pumps Ltd.  
Grovebury Road  
Leighton Buzzard/Beds. LU7 4TL  
Phone: +44-1525-850000  
Telefax: +44-1525-850011

**U.S.A.**

GRUNDFOS Pumps Corporation  
17100 West 118th Terrace  
Olathe, Kansas 66061  
Phone: +1-913-227-3400  
Telefax: +1-913-227-3500

**Uzbekistan**

Grundfos Tashkent, Uzbekistan The Repre-  
sentative Office of Grundfos Kazakhstan in  
Uzbekistan  
38a, Oybek street, Tashkent  
Телефон: (+998) 71 150 3290 / 71 150  
3291  
Факс: (+998) 71 150 3292

Addresses Revised 02.09.2016

<b>98979478</b> 1116
----------------------

ECM: 1197159
--------------