

BARNES[®]

brands you trust.

Engineered Basins

Affordable, effective pressure sewer system

Rocky, hilly, wet and flat topography

Dependable, reliable and cost effective

BARNES[®]
PRESSURE **PS** SYSTEMS

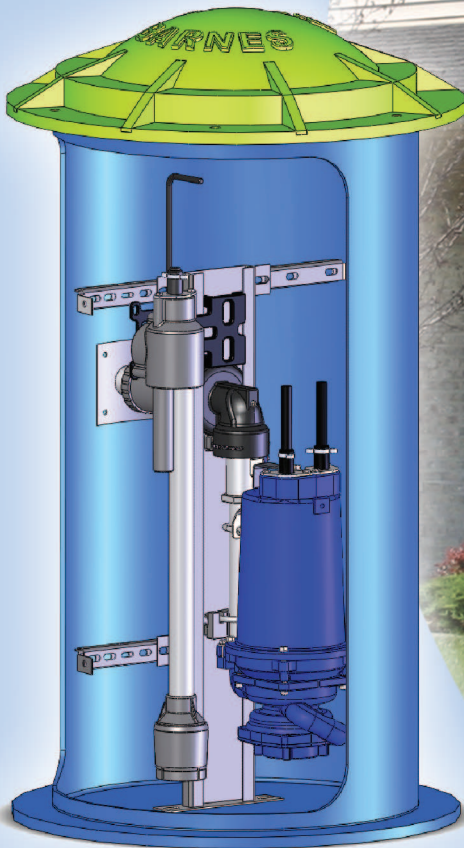



Barnes Pressure Sewer systems offer a broad range of customized engineered pressure sewer basins with reliable and dependable 2 to 7.5 hp grinder pumps in simplex, duplex, and triplex configurations to the municipal and commercial markets. The basins come in a variety of sizes to fit your specific application with custom control panels, multiple cover options and many accessories to suit your exact needs. The system can also be designed with the highly dependable Barnes ESPS™ level control or traditional float-style controls.

Pump Options

page 3-4

Grinder Pumps are the heart of pressure sewer systems. Barnes offers a wide variety of pump types and sizes to ensure that an optimal Grinder Pump is selected for the specific application. All Barnes grinder pumps utilize the Exclusive Slicerator™ to eliminate potential jams. (Available from factory with pre-wired and tested basin package, not available on 5 hp 1ph models)

Level Control Options

page 4

Several level control and mounting options are available. The ESPS pressure switch option provides the most resistance to grease or solids buildup.

Basin Options

page 5

Barnes Engineered Pressure Sewer basins are available in reinforced fiberglass in multiple diameters and custom lengths to suit simplex, duplex and triplex installations with slide rail or free-standing pump installation.

Cover Options

page 6

A variety of covers, ranging from polyethylene to fiberglass to metal, are available depending on size and intended usage.

Control Panel Options

page 6

"Stealth™", wall-mount or free-standing control panels are available in standard or custom configurations. Standard or customized alarm panels for use with "Stealth" panels are also available..

Accessories

page 7

A full range of custom accessories are also available to suit specific needs.



Pump Options

OGP

Motor	2 hp
RPM	3450
Electrical	240v 1ph 60Hz
Cord Length	30'
Construction	cast iron
Impeller	vortex bronze
Discharge	1.25" NPT
Pump Design	centrifugal

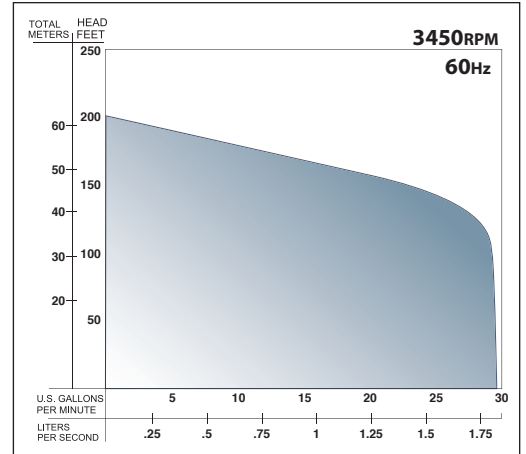

Superior Performance

- Two stage pump design provides high head capability
- Exclusive Slicerator replaceable radial grinder cutter and reversible shredder ring
- Start and run capacitors are located in the motor housing so no expensive control panel required
- UL and CSA listed to assure quality and electrical safety
- Available in manual and automatic version
- Silicon carbide mechanical seal
- Quick connect cord eliminates wiring mistakes

This product may be covered by one or more of the following patents and other patent(s) pending: US Patent 7,357,341

OGV

Motor	2 hp
RPM	3450
Electrical	240v 1ph 60Hz
Cord Length	30'
Construction	cast iron
Impeller	vortex cast iron
Discharge	1.25" NPT
Pump Design	centrifugal



OGV Advantages

- Recessed vortex impeller design virtually eliminates pump damage from cavitation
- Large pump end bearing and short impeller overhang significantly extend mechanical seal life by minimizing shaft deflection
- Exclusive Slicerator replaceable radial grinder cutter and reversible shredder ring
- Quick connect power cord
- Heavy duty 2hp motor is standard
- Available in manual and automatic version
- Silicon carbide mechanical seal

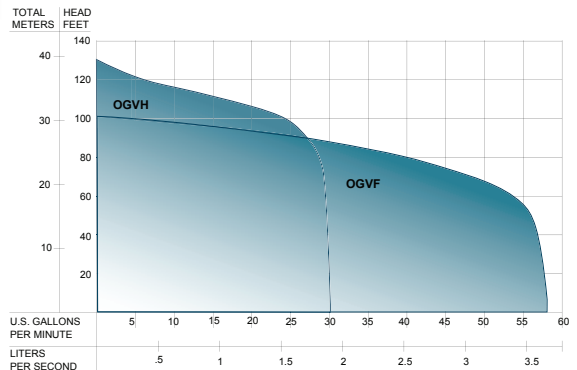

SGV

Motor	2 hp	3 hp • 5 hp	7.5 hp
RPM	3450	3450	3450
Electrical	200v 1ph & 3ph 60Hz 240v 1ph & 3ph 60Hz 480v 3ph 60Hz 600v 3ph 60Hz	200v 1ph & 3ph 60Hz 240v 1ph & 3ph 60Hz 480v 3ph 60Hz 600v 3ph 60Hz	240v 3ph 60Hz 480v 3ph 60Hz 600v 3ph 60Hz
Cord Length	30'	30'	30'
Construction	cast iron	cast iron	cast iron
Impeller	vortex cast iron	vortex cast iron	vortex cast iron
Discharge	1.25" NPT	2" NPT	2" NPT
Pump Design	centrifugal	centrifugal	centrifugal

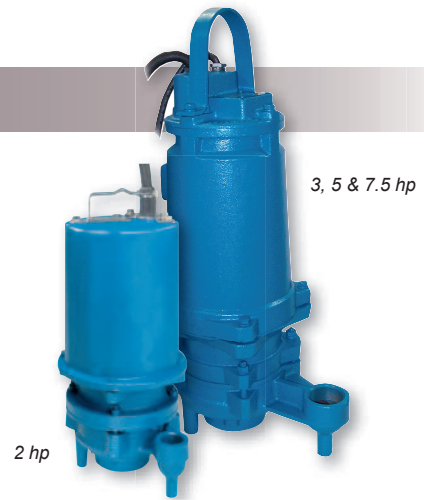

SGV Pump Advantages

- Unique and robust 3-bearing shaft support design significantly extends mechanical seal life by minimizing shaft deflection
- Recessed vortex impeller design virtually eliminates pump damage from cavitation
- Exclusive Slicerator replaceable radial grinder cutter and reversible shredder ring
- Quick-connect power cord eliminates wiring mistakes (not available on 5 hp 1ph models)
- Double mechanical seal provides clean environment for long life

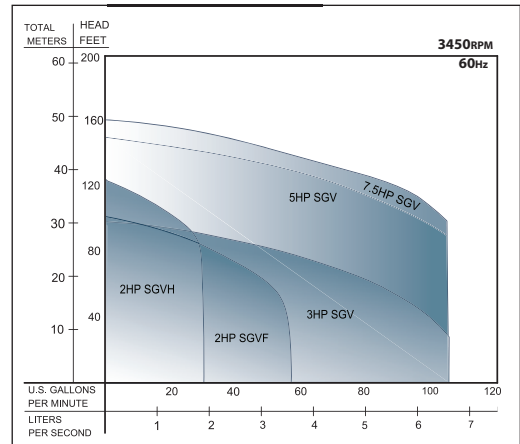

* Optional explosion proof motors also available.

Level Control Options

The Environmentally Sealed Pressure Switch, or **ESPS™**, is a highly dependable unitized level control designed specifically for use with standardized pressure sewer packaged systems.

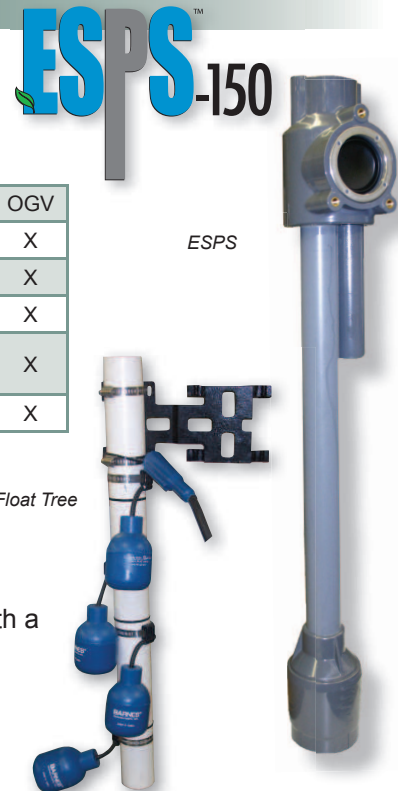

ESPS Design Features

- Pressure switch parts are protected from the basin environment with a Barnes exclusive sealed design.
- Slim, rigid column with NO moving parts. Unit is unaffected by solids, grease buildup, or liquid swirling in basin.
- Mounts easily in Engineered Basins with a rail system using a heavy duty slide bracket.
- NO field adjustment required because operating levels are factory preset.

	SGV	OGP	OGV
ESPS-100 Simplex Manual	X	X	X
ESPS-150 Simplex Automatic		X	X
ESPS-200 Duplex Manual	X	X	X
Float Tree Simplex/Duplex Manual	X	X	X
Automatic Floats		X	X

Float Tree

- Simple design
- Field adjustable operating points
- Easily mounts into basin guide rail with a heavy duty slide bracket

This product may be covered by one or more of the following patents and other patent(s) pending: US Patent 7,578,657

Basin Options

Fiberglass Basin Features:

- Custom molded fiberglass reinforced polyester resin
- Wall thickness sufficient to withstand a water-saturated sand load of 120 lbs per cubic foot with a 1.5 safety factor
- Ballast support flange extends three inches on the radius of the basin
- Basin will withstand a maximum temperature of 150°F
- Factory pre-wiring available
- Simplex, duplex or triplex configuration



C-Channel Rail Options:

- Stainless steel discharge piping
- For use with 1.25" and 2" NPT discharge grinder, solids handling, and effluent pumps
- 24" - 60" basin diameters
- 48" - 240" basin lengths

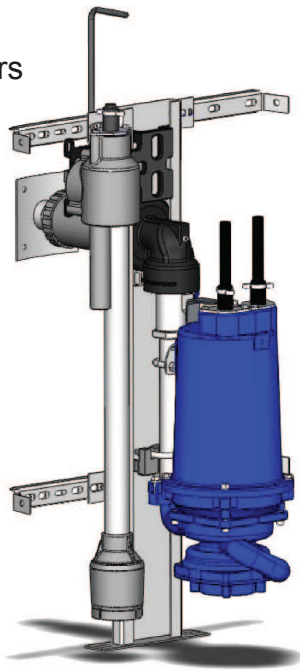

Flex Hose Options:

- EPDM Hose and PVC Piping
- For use with 1.25" NPT discharge grinder
- 24" basin diameter
- 48" - 96" basin lengths

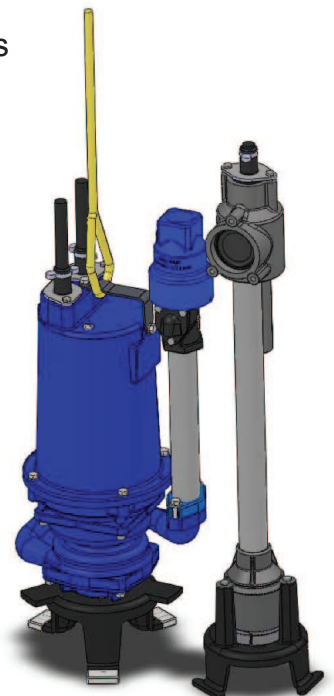

Cover Options

Ultra Cap₂

- Rugged, polyethylene removable self-venting drywell and cover are engineered to fit the 24" and 30" reduced opening diameter basins used on pre-wired package systems.

Molded Polyethylene

- Rugged, light weight rotomolded polyethylene grass green cover that is self-vented and engineered to fit all standard 24" and 30" reduced diameter basins.

Fiberglass

- Reinforced plastic and are grass green in color. Covers for 24" and 30" diameters are 5/16" thick, 36" and 42" diameters are 3/8" thick.

Steel

- Steel cover has a black powder coating. Covers available for basin diameters 36" through 60" and are 3/8" thick.

Aluminum

- Available for basin diameters 36" through 60" and are 1/4" thick.

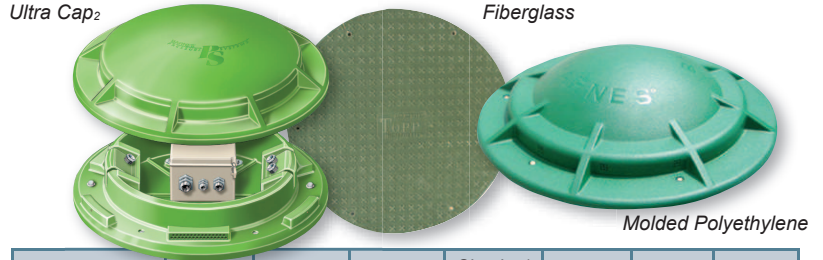

	Simplex 24	Reduced 30	Simplex 30	Simplex/Duplex 36	Duplex 42	Duplex 48	Duplex 60
Polyethylene	X	X					
Ultra Cap ₂	X	X					
Aluminum				X	X	X	X
Fiberglass	X	X	X	X	X		
Steel				X	X	X	X

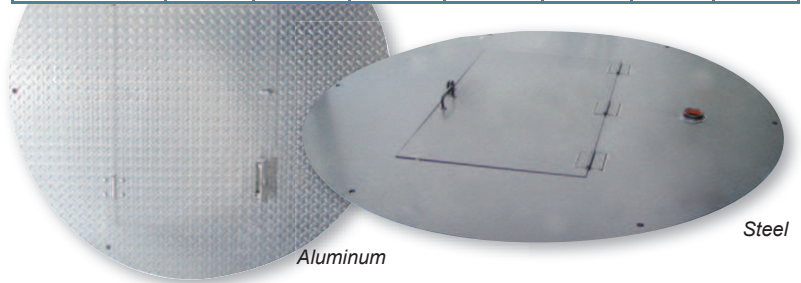

Control Panel Options

Stealth™ Control Panels

Listed by Underwriters Laboratories, simplex and duplex pump control panels provide reliable grinder pump station operation and potential malfunction warning.

Standard Features:

- Simplex and Duplex Wall Mounted Series
- Simplex, Mount Series for Ultra Cap₂ cover
- Fiberglass enclosure
- Padlockable Latch
- Pump and Alarm Circuit Breakers
- IEC Rated Motor Contactor
- Pump Start Push Button
- Terminal Strip and Ground Lug for Incoming Connections
- Alarm light and audible alarm with silence

Optional Features:

- 7 Digit Elapsed Time Meter with running meter indicator
- Transfer switch with easy access reverse pin portable generator receptacle and weatherproof cover
- Moisture sensors
- Intrinsically safe barriers
- Cycle counter

STEALTH™
CONTROL PANELS





1. Flexible Inlet Pipe Fittings

The Flexible Pipe fitting is super tough for weather and corrosion resistance. The fitting has superior vapor and water leakproof sealing ability. Available 1¼" thru 6".

2. Flexible Discharge

Braided stainless steel flexible discharge protects against damage from soil settling.

3. Inlet Hubs

Cast iron inlet hubs are recommended for cast iron, ceramic, plastic or ductile iron gravity sewer pipe, and are designed to fit curvature of basin.

4. Electrical Conduit Hubs

Bolt-On Hub, constructed of glass filled nylon.

5. Discharge Couplings

Stainless Steel Bolt-On Couplings available in 1¼", 1½", 2", and 2½" NPT sizes.

6. Bulkhead Fitting

Safety lock design permits safe, quick pipe connection. Fitting comes standard with heavy duty buttress threads to help prevent leaks under pressure.

7. "C" Channel Guide Rails

Rail mounts to the upper and lower horizontal brackets, attached to the basin wall. The rail rests on the bottom of the basin floor, supporting the pump and the required distance from the basin floor. Guide brackets are attached to the pump for positioning of the unit on the guide rail during installation and removal.

8. True Union Ball Valves

Manufactured of Sch. 80 PVC type I with EPDM o-rings for superior chemical and corrosion resistance. 1.25" & 2.00" NPT ball valves are of quick disconnect design with full port bore, ¼ turn leak tight shut-off and NSF listed for use in water service.

9. Ball Check Valve

1.25", 1.50" and 2.00" NPT are available in cast iron or PVC. Works both vertically and horizontal. Ball has sufficient weight to seat tightly and moves freely to open. Head loss is low as the ball is set completely to one side at the maximum rate of flow.

10. Swing Check Valve

Made of high impact Sch. 40 PVC type II material, suitable in systems where fluid is corrosive or contains debris, industrial waste disposal, sewage, etc. The EPDM swing gate lifts to provide unobstructed flow. 1.25" through 2.00" NPT.

11. Swing Check Valve with Integrated Anti-Siphon

Available in 1.25" and 2.00" NPT C-Channel and 1.25" NPT In-Line configurations. Cast iron construction with powder coat finish.

12. Remote Alarm Wall Plate

Allows the homeowner to install a fault warning light indoors. Available in various color options and installs in a standard single gang style enclosure.

Visit our website to read
Case Studies on
Pressure Sewer *SUCCESS* stories!

CRANE[®]

A Crane Co. Company

PUMPS & SYSTEMS

Crane Pumps & Systems

420 Third Street
Piqua, Ohio 45356
(937) 778-8947
Fax (937) 773-7157
www.cranepumps.com

Crane Pumps & Systems Canada

83 West Drive
Brampton, Ont. Canada L6T 2J6
(905) 457-6223
Fax (905) 457-2650

© 2012 Crane Pumps & Systems, Inc.
A Crane Co. Company
Printed in U.S.A.
BPSENFULL - Rev. F (1/12)

brands you trust.

BARNES[®]

burks[®]

DEMING[®]

WEINMAN[®]



PROSSER[®]