

STA-RITE® FN Series

Cast iron self-priming shallow well jet pumps



The FN Series provides strong performance with good pressure for wells to 25' deep. Self-priming after the priming chamber has been filled with water.

APPLICATIONS

Water systems and sprinkling...
for homes, farms and cottages.

SPECIFICATIONS

FNC Priming Time (in minutes):

at 15': 2.25 minutes max.
at 25': 6.5 minutes max.

FND Priming Time (in minutes):

at 15': 1.7 minutes max.
at 25': 4.4 minutes max.

Max. Liquid Temperature: 140°F

FNC Max. Inlet Pressure: 60 PSI

FND Max. Inlet Pressure: 50 PSI

Max. Inlet PSI + Pump Discharge PSI:
Not to exceed 100 PSI

Body and Base: Close-grained cast iron

Nozzle: High-strength polycarbonate

Venturi: Polycarbonate

Impeller: Noryl®

Diffuser: Reinforced polypropylene

Shaft: One-piece threaded stainless steel

FEATURES

Quality Construction: Close-grained cast iron body and base, specially treated for corrosion resistance. Drain port provided for easy winterizing.

Built-in Jet: High-strength polycarbonate nozzle and venturi for maximum resistance to corrosion and abrasion. Cleanout plug provided for ease of service.

Noryl Impeller: Precision-molded for perfect balance...ultra-smooth for highest performance and efficiency.

Precision-Molded Diffuser: Pump primes faster, handles more air, with multi-port, precision-molded, reinforced polypropylene diffuser.

Mechanical Shaft Seal: Precision lapped and highly polished carbon-ceramic, stainless steel construction. Internal design guarantees continuous water lubrication.

Motor Windings: Superior insulation materials protect against excessive moisture and contaminants...assure prolonged motor life.

Balanced Rotor: Diecast under high pressures for uniform performance and greater efficiency, dynamically balanced.

Heavy-Duty Ball Bearings: Sealed, permanently lubricated bearings, extensively tested to ensure extended life and smooth, quiet operation.

Pump and Motor Shaft: Stainless steel for maximum corrosion resistance; one-piece threaded shaft for positive impeller drive and alignment.

Dustproof Cover: All electrical components are protected from dirt, dust and insects by a dustproof canopy; ventilating air cannot contaminate vital switching components.

Pressure Switch: Adjustable cut-in and fixed differential (20 PSI).

ORDERING INFORMATION

CATALOG NUMBER	HP	SWITCH SETTING	DESCRIPTION	PIPE TAPPING SIZES		MOTOR VOLTAGE	APPROX. WT. LBS.
				SUCTION	DISCHARGE		
FNC	1/2	30-50	Shallow Well Jet	1-1/4"	1"	115/230	46
FND	3/4	30-50	Shallow Well Jet	1-1/4"	1"	115/230	47

Noryl® is a registered trademark of General Electric Co.
All other brand or product names are trademarks or registered trademarks of Pentair Ltd.

STA-RITE® FN Series

Cast iron self-priming shallow well jet pumps

OUTLINE DIMENSIONS

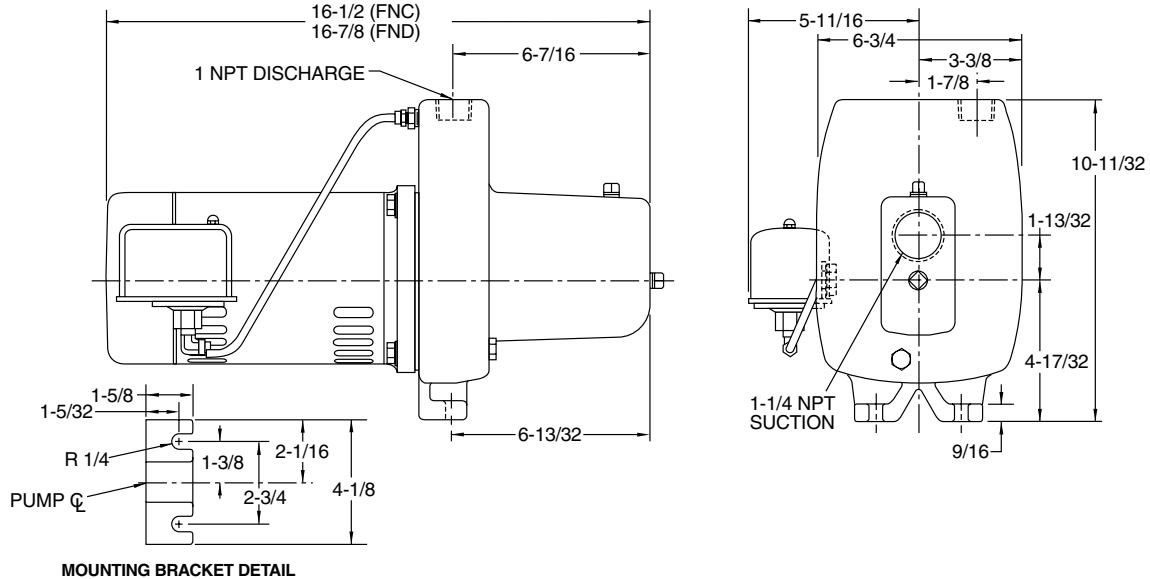

Dimensions (in inches) are for estimating purposes only.

PUMP PERFORMANCE

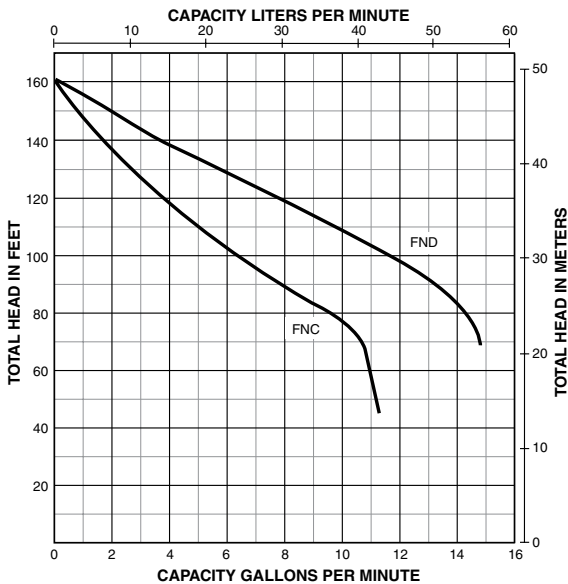

PUMP PERFORMANCE (CAPACITY IN GALLONS PER MINUTE)

CATALOG NUMBER	HP	DISCH. PRESSURE		DYNAMIC SUCTION LIFT					SHUT-OFF PRESSURE PSI
		PSI	FEET HEAD	5'	10'	15'	20'	25'	
FNC	1/2	20	46.2	9.8	8.8	7.5	6.2	4.5	69
		30	69.3	9.2	8.2	7.2	5.9	4.2	
		40	92.4	6.9	6.0	5.3	4.5	4.0	
		50	115.5	3.8	3.5	2.7	1.9	1.4	
FND	3/4	30	69.3	15.0	13.0	11.6	8.7	6.9	70
		40	92.4	12.5	11.4	10.1	8.2	6.8	
		50	115.5	8.0	6.8	6.1	4.8	3.5	

Pump will operate at all depths shown, with pressure switch set at 30-50 PSI.

Tested and rated in accordance with Water Systems Council Standards.

NOTE: Pumps installed with a Pro-Source® tank require a 100 PSI relief valve. Pumps installed with a conventional tank require a 75 PSI relief valve. Relief valve must be capable of relieving entire flow of pump at relief pressure.