

Josh Groban
Harmony Tour
Red Rocks 2022

LIGHTING DIRECTOR:
AMY EDGE

PRODUCTION MANAGER:
Jimmy Pettinato
jimmyspet@mac.com

RR Stage Plan
Sheet: S1

File name: JG-RedRocks-220724-02.vwx
Generated: 2022-07-12 / 11:42:18 AM

THIS DRAWING AND ALL ACCOMPANYING SPECIFICATIONS ARE PROPERTY OF PENLIGHT INC. ANY REPRODUCTION OR PUBLIC EXHIBITION CAN ONLY BE AUTHORIZED BY PERSONS NAMED HEREIN.

THIS DRAWING IS AN ILLUSTRATION OF DESIGN CONCEPTS ONLY. ALTHOUGH DIMENSIONS ARE ACCURATE AND PROPORTIONALLY TO SCALE, THE DESIGNER MAKES NO CLAIM THAT THE PHYSICAL CONSTRUCTION OF THIS DESIGN IS PLAUSIBLE FROM AN ENGINEERING STANDPOINT. VENDORS ARE TO VERIFY THE SAFETY OF ALL FABRICATIONS AND IMPLEMENTATION OF THIS DESIGN AND ARE TO CONSULT WITH A REGISTERED ENGINEER WHERE APPLICABLE.

ALL VENDORS TO COMPLY WITH SAFETY STANDARDS ESTABLISHED BY LOCAL AUTHORITIES IN ALL VENUES WHERE STAGE, SET OR LIGHTING APPARATUS INSPIRED BY THIS DESIGN ARE INSTALLED.

DESIGN:
JEFF FARROW &
AJ PEN
penlight



© 2021 PENLIGHT INC

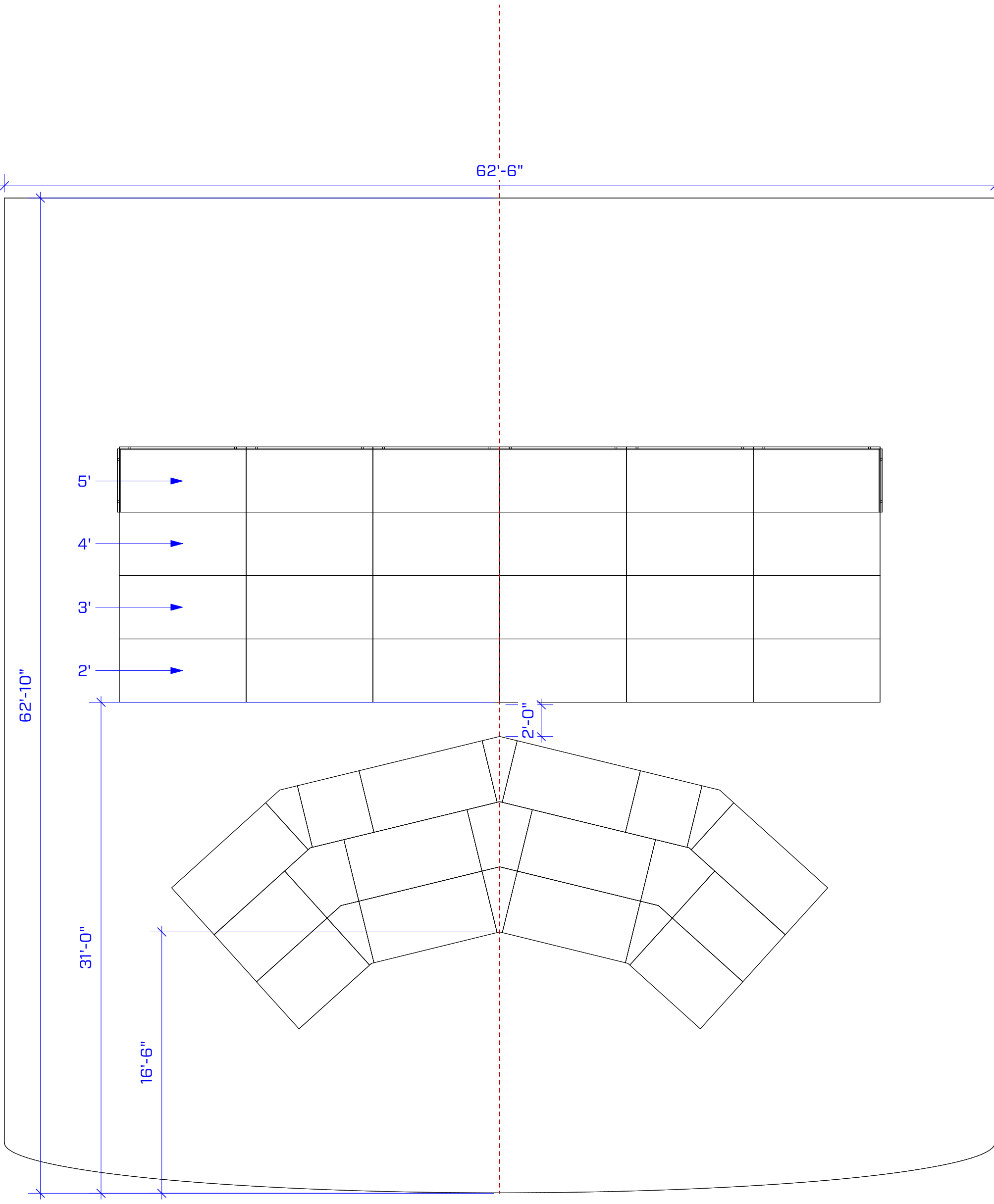

Josh Groban
 Harmony Tour
 Red Rocks 2022

LIGHTING DIRECTOR:
 AMY EDGE

PRODUCTION MANAGER:
 Jimmy Pettinato
 jimmypet@mac.com

RR Stage Dims
 Sheet: S2

File name: JG-RedRocks-220724-02.vwx
 Generated: 2022-07-12 / 11:42:19 AM

THIS DRAWING AND ALL ACCOMPANYING SPECIFICATIONS ARE PROPERTY OF PENLIGHT INC. ANY REPRODUCTION OR PUBLIC EXHIBITION CAN ONLY BE AUTHORIZED BY PERSONS NAMED HEREIN.

THIS DRAWING IS AN ILLUSTRATION OF DESIGN CONCEPTS ONLY. ALTHOUGH DIMENSIONS ARE ACCURATE AND PROPORTIONALLY TO SCALE, THE DESIGNER MAKES NO CLAIM THAT THE PHYSICAL CONSTRUCTION OF THIS DESIGN IS PLAUSIBLE FROM AN ENGINEERING STANDPOINT. VENDORS ARE TO VERIFY THE SAFETY OF ALL FABRICATIONS AND IMPLEMENTATION OF THIS DESIGN AND ARE TO CONSULT WITH A REGISTERED ENGINEER WHERE APPLICABLE.

ALL VENDORS TO COMPLY WITH SAFETY STANDARDS ESTABLISHED BY LOCAL AUTHORITIES IN ALL VENUES WHERE STAGE, SET OR LIGHTING APPARATUS INSPIRED BY THIS DESIGN ARE INSTALLED.

DESIGN:
 JEFF FARROW &
 AJ PEN
 penlight



© 2021 PENLIGHT INC

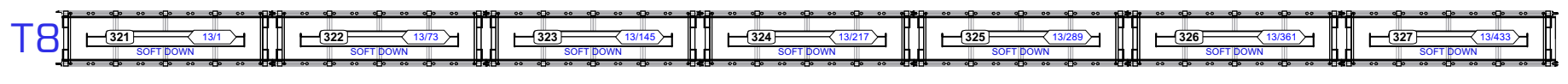
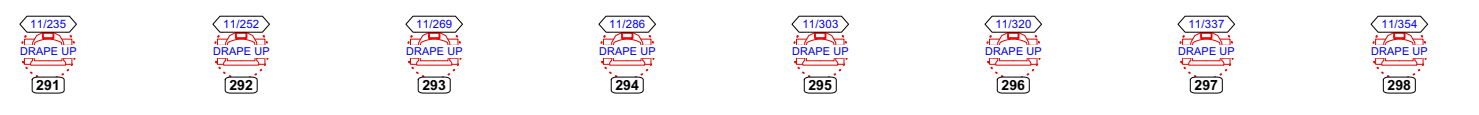
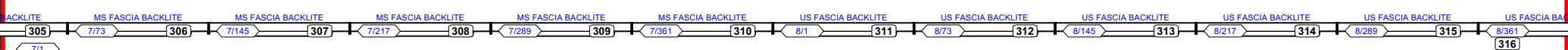

T1

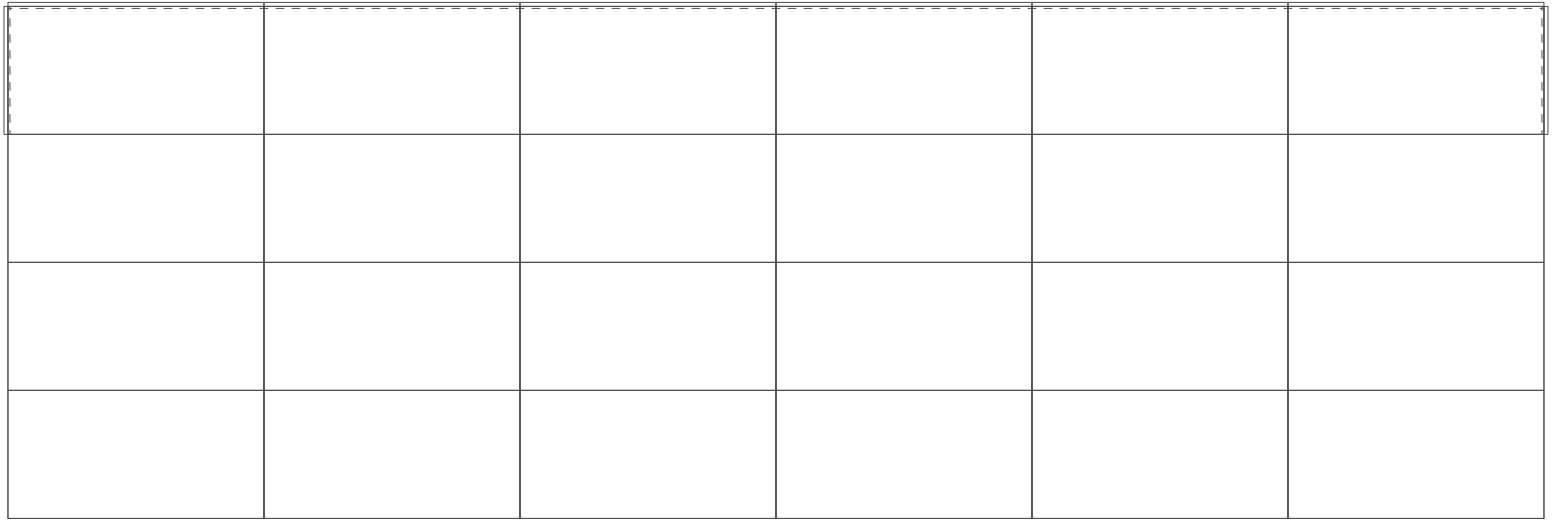
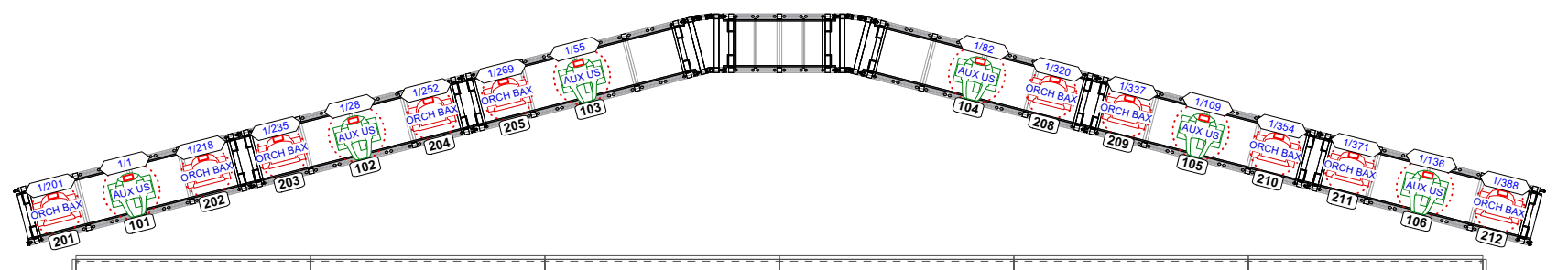

T4

T2

T5

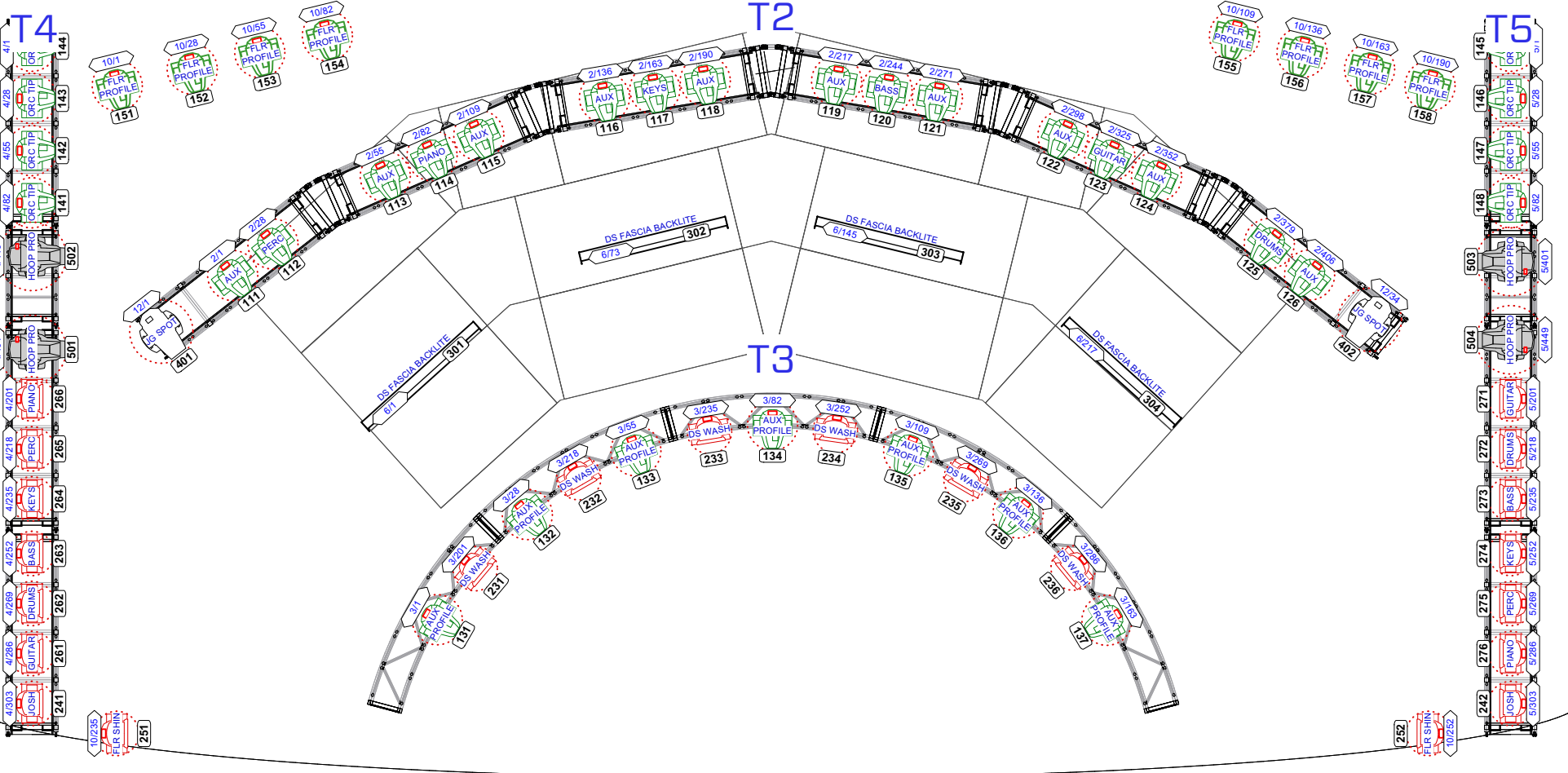

T3

T6

T7

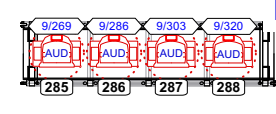
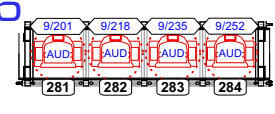

T1 & THE DRAPE TRUSS MOVE US TO ACCOMMODATE THE LARGER ORCHESTRA RISER
 NO DRAPE IS HUNG, BUT THE CF72 ON THE DRAPE TRUSS ARE HUNG AND FOCUSED TO THE ROCK FACE
 THE UNDER RISER ORCHESTRA CF72 ARE SHIFTED US TO LIGHT THE ROCK FACE WITH BORDER LENSES,
 THESE MAY BE ON CASES IF THAT WORKS DAY OF



Josh Groban
 Harmony Tour
 Red Rocks 2022

LIGHTING DIRECTOR:
 AMY EDGE

PRODUCTION MANAGER:
 Jimmy Pettinato
 jimmypet@mac.com

RR LX
 Sheet: S3

File name: JG-RedRocks-220724-02.vwx
 Generated: 2022-07-12 / 11:42:21 AM

THIS DRAWING AND ALL ACCOMPANYING SPECIFICATIONS ARE PROPERTY OF PENLIGHT INC. ANY REPRODUCTION OR PUBLIC EXHIBITION CAN ONLY BE AUTHORIZED BY PERSONS NAMED HEREIN.

THIS DRAWING IS AN ILLUSTRATION OF DESIGN CONCEPTS ONLY. ALTHOUGH DIMENSIONS ARE ACCURATE AND PROPORTIONALLY TO SCALE, THE DESIGNER MAKES NO CLAIM THAT THE PHYSICAL CONSTRUCTION OF THIS DESIGN IS FEASIBLE FROM AN ENGINEERING STANDPOINT. VENDORS ARE TO VERIFY THE SAFETY OF ALL FABRICATIONS AND IMPLEMENTATION OF THIS DESIGN AND ARE TO CONSULT WITH A REGISTERED ENGINEER WHERE APPLICABLE.

ALL VENDORS TO COMPLY WITH SAFETY STANDARDS ESTABLISHED BY LOCAL AUTHORITIES IN ALL VENUES WHERE STAGE, SET OR LIGHTING APPARATUS INSPIRED BY THIS DESIGN ARE INSTALLED.

DESIGN:
 JEFF FARROW &
 AJ PEN
 penlight



© 2021 PENLIGHT INC

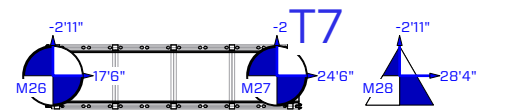
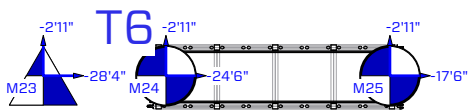
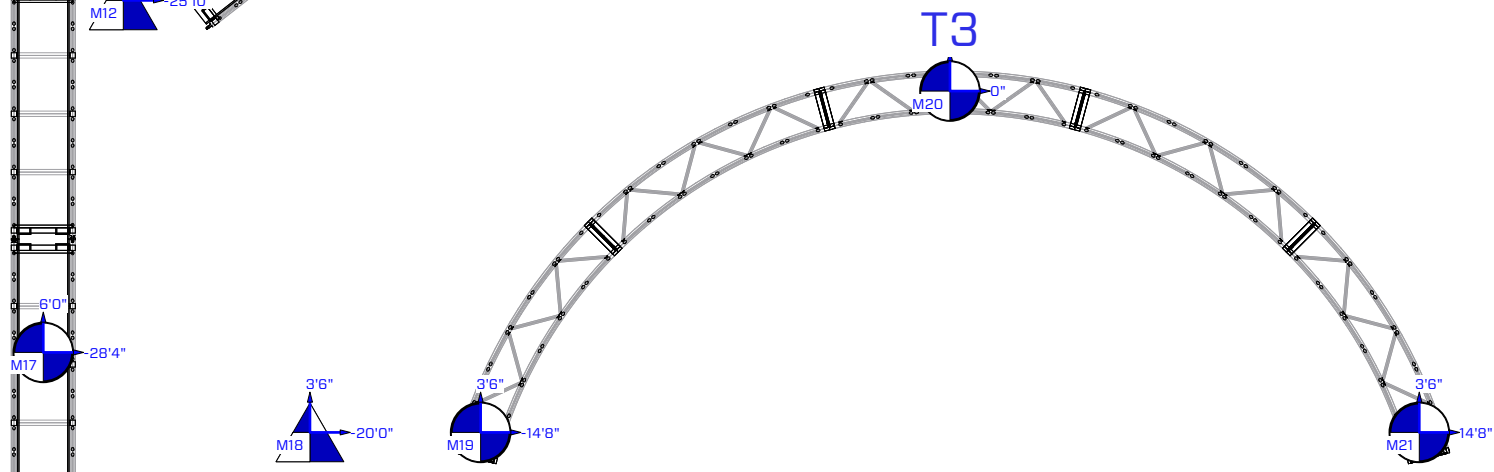
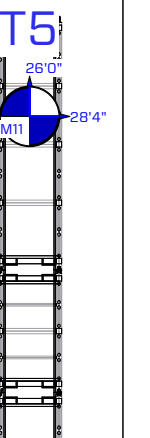
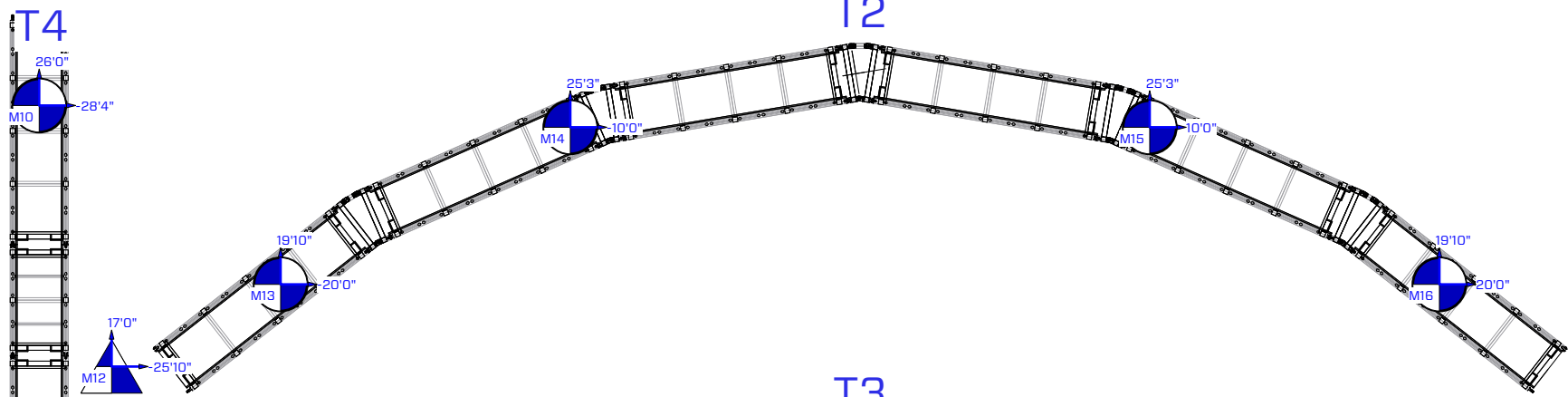
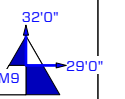
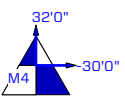
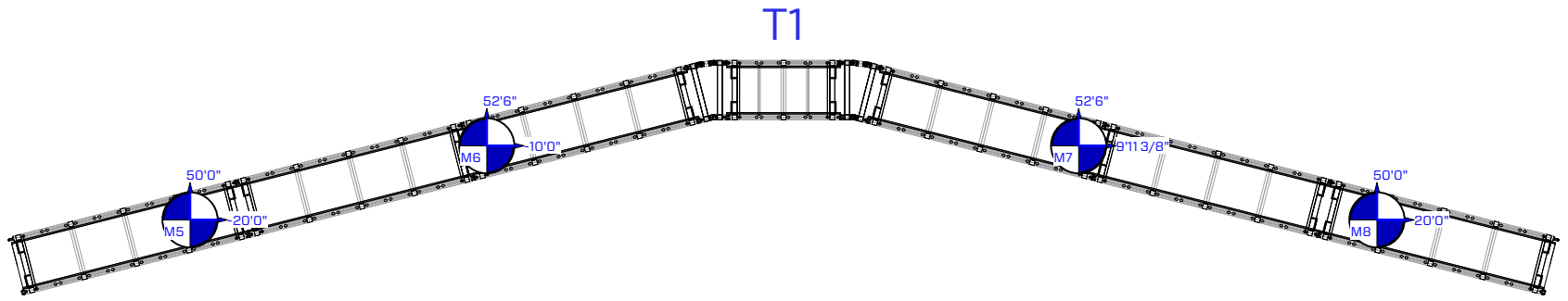
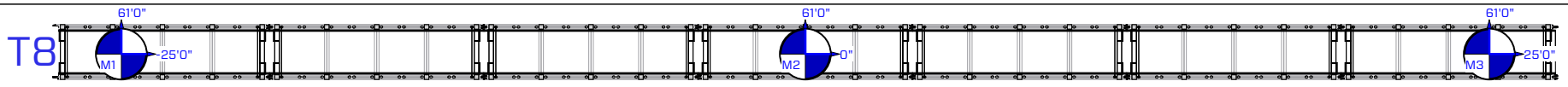

Josh Groban
Harmony Tour
Red Rocks 2022

LIGHTING DIRECTOR:
AMY EDGE

PRODUCTION MANAGER:
Jimmy Pettinato
jimtypet@mac.com

RR Rigging
Sheet: S4

File name: JG-RedRocks-220724-02.vwx
Generated: 2022-07-12 / 11:42:22 AM

THIS DRAWING AND ALL ACCOMPANYING SPECIFICATIONS ARE PROPERTY OF PENLIGHT INC. ANY REPRODUCTION OR PUBLIC EXHIBITION CAN ONLY BE AUTHORIZED BY PERSONS NAMED HEREIN.

THIS DRAWING IS AN ILLUSTRATION OF DESIGN CONCEPTS ONLY. ALTHOUGH DIMENSIONS ARE ACCURATE AND PROPORTIONALLY TO SCALE, THE DESIGNER MAKES NO CLAIM THAT THE PHYSICAL CONSTRUCTION OF THIS DESIGN IS PLAUSIBLE FROM AN ENGINEERING STANDPOINT. VENDORS ARE TO VERIFY THE SAFETY OF ALL FABRICATIONS AND IMPLEMENTATION OF THIS DESIGN AND ARE TO CONSULT WITH A REGISTERED ENGINEER WHERE APPLICABLE.

ALL VENDORS TO COMPLY WITH SAFETY STANDARDS ESTABLISHED BY LOCAL AUTHORITIES IN ALL VENUES WHERE STAGE, SET OR LIGHTING APPARATUS INSPIRED BY THIS DESIGN ARE INSTALLED.

DESIGN:
JEFF FARROW &
AJ PEN
penlight



© 2021 PENLIGHT INC