

Step 1: Remove Inside Skin. Do Not Cut Into Any Tubes.

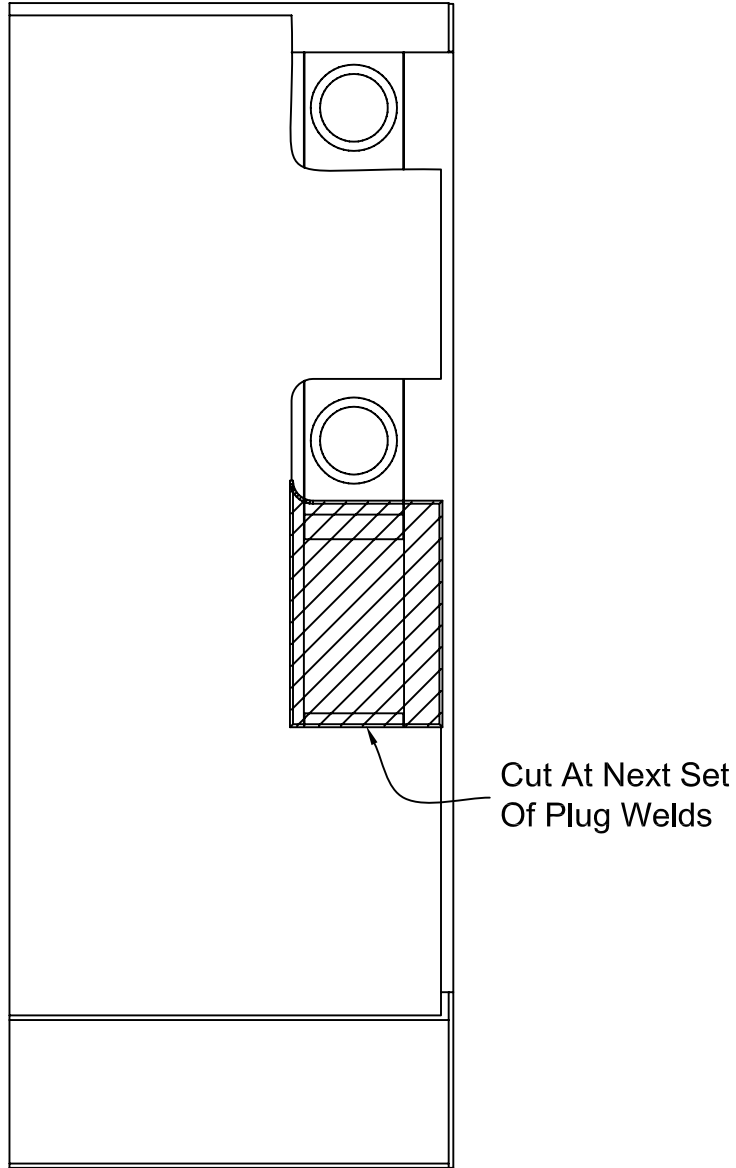

Step 2: Add Blocking, Weld Where Possible.

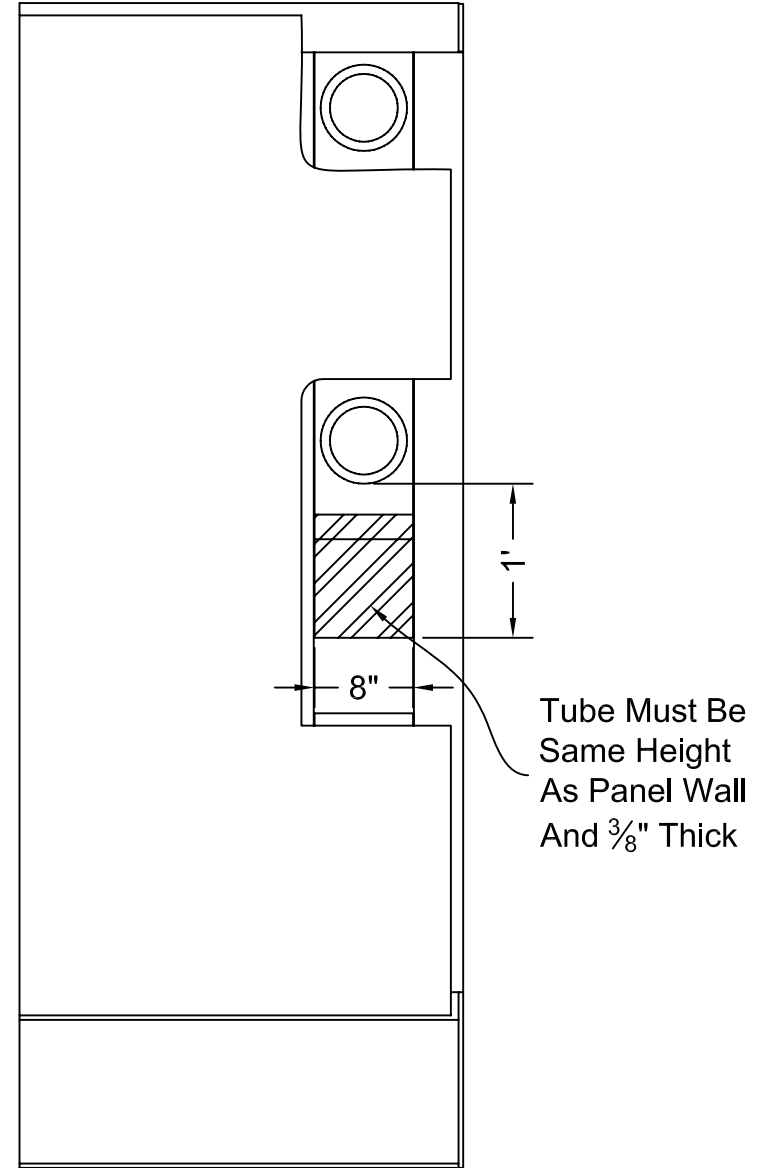

Note: All Material To Be 55 Ksi Min. Yield Or Equivalent Unless Otherwise Noted.



Step 3: Add Pull Lug, Weld Where Possible.

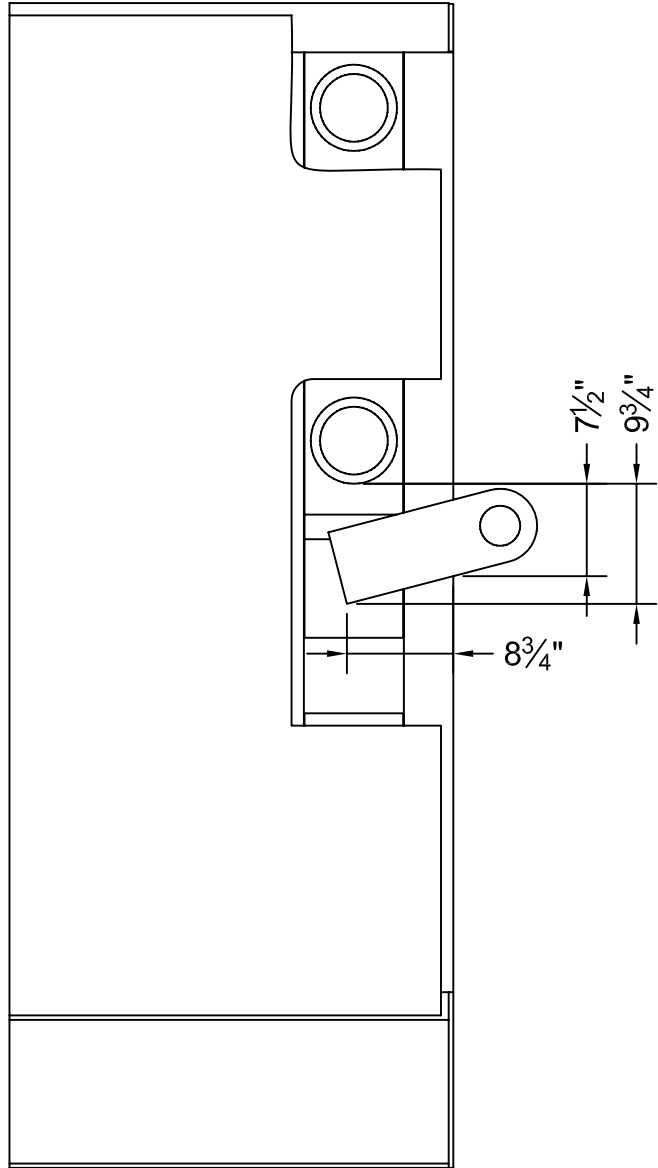

Step 4: Replace Skin, Weld Where Possible.

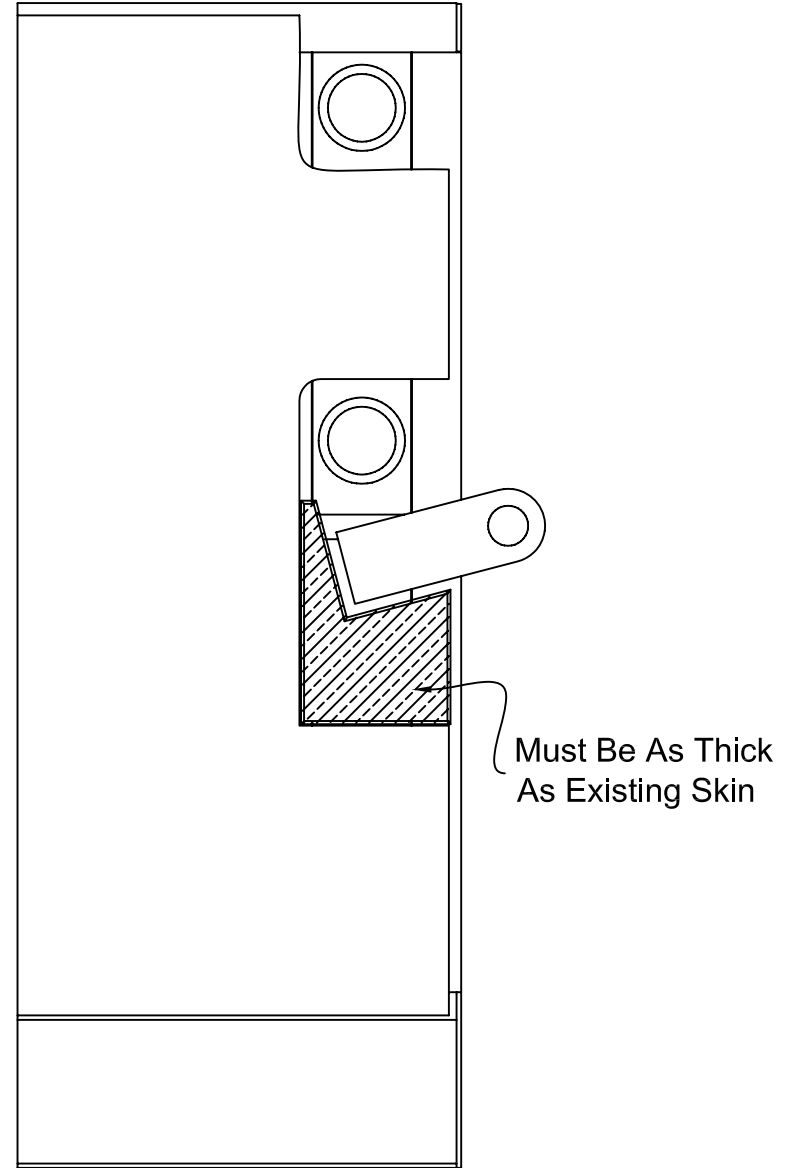

Note: All Material To Be 55 Ksi Min. Yield Or Equivalent Unless Otherwise Noted.

