

## 24 INCH VENTLESS HEAT PUMP DRYER

DHP24400W

### Compact Washer & Dryer

Blomberg knows an upscale urban lifestyle often puts space at a premium, but that doesn't mean sacrificing style or superior performance. Our 24-inch compact washers and dryers fit in perfectly, offering flexibility and freedom in installation (including an optional stacking kit), plus all the functionality and finesse required for expert clothing care. Despite their compact size, these washers deftly handle 2.5 cu. ft. of laundry while the dryers dry 4.1 cu. ft. loads—both with a variety of cycles for different fabrics.



### In Harmony with Nature



Commitment to living consciously should extend to clothing care, so Blomberg brings intelligent energy and water conservation to the laundry room. All our washers are ENERGY STAR<sup>®</sup> certified and offer automatic water adjustment for each load. The same is true for all our dryers, including Blomberg's best-in-class Heat Pump Dryer which made the **2017 ENERGY STAR Most Efficient** list for using **50% less energy** than conventional dryers. Thoughtful design and engineering is what earned Blomberg the ENERGY STAR<sup>®</sup> 2017 Partner of the Year Award.

### In Harmony with Your Life



#### Ventless Heat Pump Dryer

Always in the vanguard, Blomberg was among the very first to bring innovative ventless heat pump technology to the market. The ultimate solution for compact spaces and dwellings where it's impractical or impossible to vent to the outside, this dryer uses a closed loop heat exchange system to dry at lower temperatures, saving money on energy bills and providing superior protection for clothes.

#### Stack Kit Included

Where and how you want to place your laundry equipment depends on your lifestyle preferences, as well as your home's unique style, layout, and space considerations. By furnishing this easy-to-install kit with every washer, Blomberg offers abundant flexibility and a safe way to keep aesthetic harmony between washer and dryer no matter where they fit in your life.



#### Anti-creasing Option

The gentle drum action of a Blomberg dryer separates and smooths out individual garments as they dry, so when the cycle finishes clothes come out wrinkle-free and ready to wear. But just in case you're not immediately available when the cycle stops, this clever option keeps the drum rotating periodically for up to two hours and keeps your clothes from creasing.

#### Gentle Care

Blomberg's closed loop heat exchange system means our heat pump dryers use a circulating air temperature that is consistently 40 percent lower than conventional dryers. This gentle care helps keep all fabrics—even woolens—at their best and extend garment life.

#### Quick Drying

Blomberg's advanced ventless heat pump dryers offer the epitome of more than just energy conservation. They save time. An 8.45 lb. load will dry in less than one hour. They also save your clothes. Faster drying and cooler temperatures reduce friction and shrinkage for clothes that look their best and last longer.

## 24 INCH VENTLESS HEAT PUMP DRYER

### DHP24400W

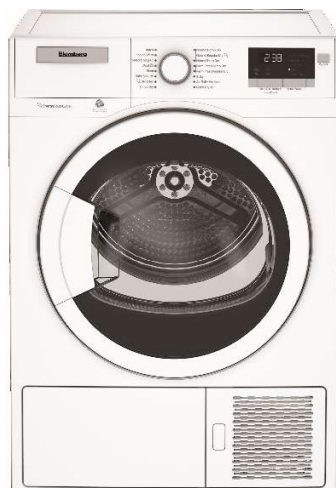

#### Main Features

- Compact dryer
- 50% less energy saving. Most Efficient 2107
- Ventless heat pump dryer technology
- 16 drying programs
- Electronic Controls
- 4.1 cu-ft dryer capacity
- Child Lock
- Stack kit included
- Reversible door
- Direct draining
- Anti-creasing
- Quick drying
- Jeans cycle
- Gentle care
- Special drum paddles
- Easy access to lint filter
- Lifetime stainless steel drum

#### Dimensions

H x W X D: 33 5/16" x 23 3/8" x 26 9/16"

GENERAL	DHP24400W
Dryer Type	Heat pump ventless
Capacity cu. ft.	4.1
Dry load capacity kg	8.0
Dry load capacity lbs.	17.7
Drum material	Stainless steel
Control	Digital Display
Silence level dBA	65
Automatic water drain	Yes
Reduce static cling	Yes
Delay Time	0-24 h
CYCLES	
Number of Cycles	16
Normal / Regular cotton	Yes
Permanent press	Yes
Mixed fabric	No
Delicates	Yes
Bulky	Yes
Air Fluff / no heat	Yes
Woolens	Yes
Jeans	Yes
Baby sanitize	Yes
Silent Program	Yes
Jogging Wear	Yes
Quick Dry 30'	Yes
Timed Dry	10-20-30-40-50-60-70-80-100-120-140-160 min
FUNCTIONS	
End of cycle buzzer	Yes
Child lock	Yes
Automatic easy ironing	Yes
Interior drum led lighting	No
Glass door with heat protection	Yes
Reversible glass door	Yes
Program follower	Yes
Levelling legs	4
Clean filter indicator	Yes
Number of vent options	4
Bi-directional drum action	Yes
Low heat	No
Auto cool-down phase	Yes
MATERIALS AND FINISHES	
Cabinet	White
Door rim	White
Cycle selector knob	Sliver
DIMENSIONS	
Product Dimensions (HxWxD) in	33 5/16" x 23 3/8" x 26 9/16"
Product Dimensions (HxWxD) cm	84.6 x 60 x 67.5
Product Weight kg	52.5
Product Weight lbs.	116
TECHNICAL FEATURES	
Rated Current Amps	5
Voltage/ Frequency	208 - 240V / 60Hz
Watts (W)	900
ENVIRONMENTAL STANDARDS	
Energy star qualified	Yes
Energy consumption kWh/year	190
UL listed	Yes
RoHS compliant	Yes
Stacking Kit Included	
Can be mounted with matching WM models (WM98400SX2, WM98400SX, WM98200SX2, WM98200SX)	2985400200

## 24 INCH VENTLESS HEAT PUMP DRYER

DHP24400W

### Dimensions and Installation

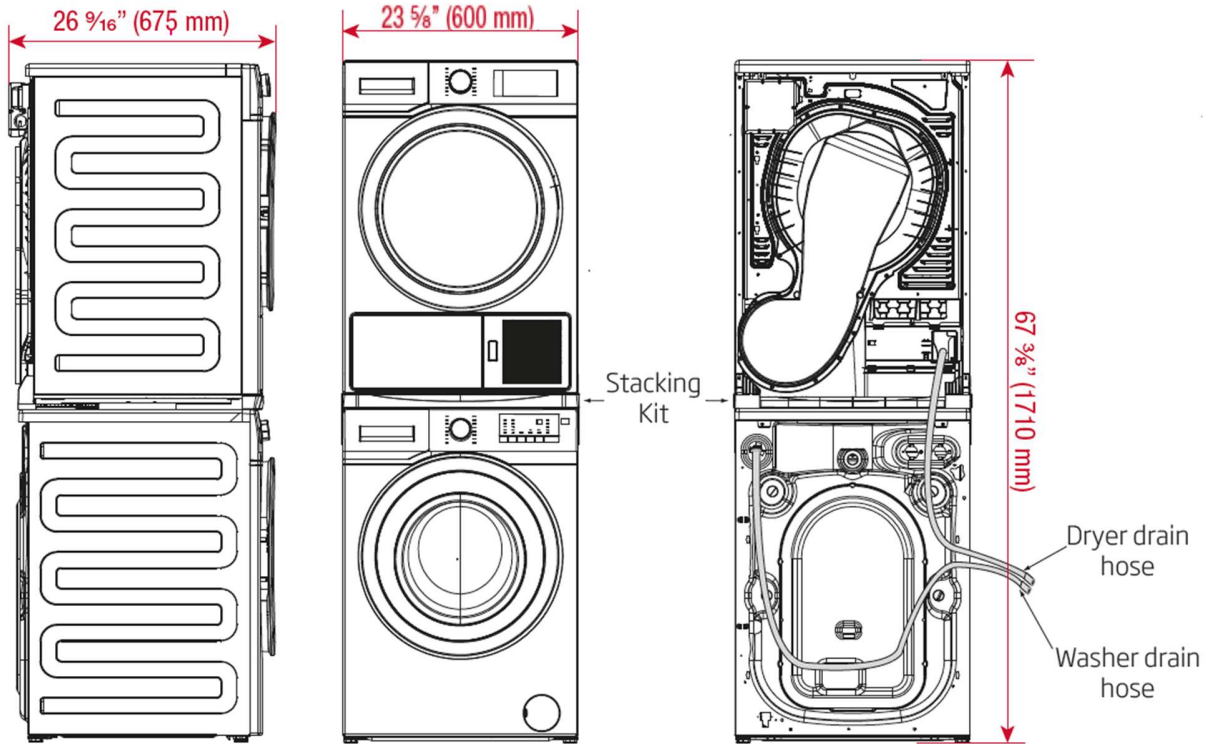

**Stacked installation minimum air gap clearances:**  
6 <sup>1</sup>/<sub>4</sub>" top, <sup>1</sup>/<sub>2</sub>" sides, <sup>1</sup>/<sub>2</sub>" back, front <sup>1</sup>/<sub>2</sub>"

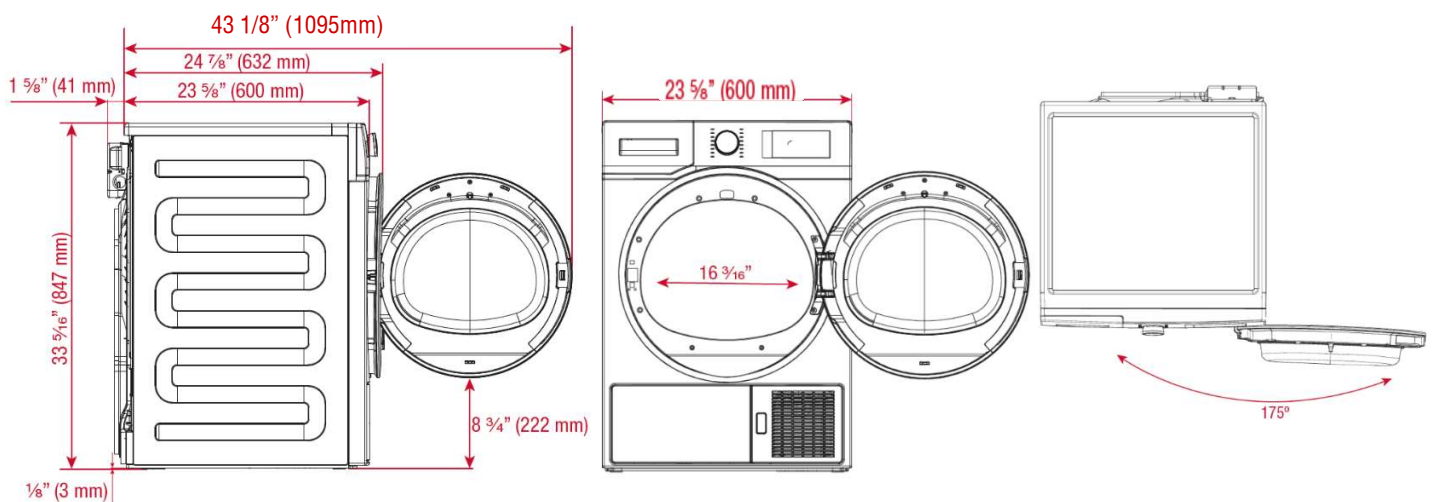

NOTE TO THE INSTALLER: All height, width and depth dimensions are shown in inches (as well as metric). Beko US Inc. reserves the absolute and unrestricted right to change product materials and specifications, at any time, without notice. Please visit our website [www.blombergappliances.us](http://www.blombergappliances.us) or call 888 352 2356 to verify the latest specifications with final dimensional data and other details prior to installation and making a cutout. Applicable product limited warranty information may be found in accompanying product materials or you may contact your account manager for further details. Proper installation is the responsibility of the installer. Product failure due to improper installation is not covered under the Limited Warranty.