











# ASSEMBLY INSTRUCTION FOR

## TWIN MUSIC BED BY520TH / BY520TF / BY520TFR BY720TH / BY720TF / BY720TFR

Caution: Please read instructions thoroughly before unpacking assembly parts. Sharp, exposed staple tips can cause injury, therefore, for your protection, please remove any exposed staples used in packing.

1. We recommend that you should assemble this product with the assistance of another person; this will make assembly easier, and will help to eliminate damage the product or injury to persons during assembly.
2. Be sure to check all packing materials carefully for small parts that may have come loose inside the carton during shipment.
3. Please do not over tighten screws or bolts.
4. Please put all parts on a non-abrasive floor before assembly, and follow the assembly steps to assemble your newly purchased product correctly and efficiently.

PART LIST				
NO.	PART DESC.	PART	CODE	QTY
A	HEADBOARD		BY520TH BY720TH	1 pc
B	HB - LEG (L / R)		PBY520HBLEG PBY720HBLEG	2 pcs
C	HB - STRETCHER		PBY520THSTR PBY720THSTR	1 pc
D	HB - STRETCHER X		BY520TH BY720TH	1 pc

HARDWARE LIST					
NO.	HARDWARE DESC.	PART	SIZE	CODE	QTY
1	ALLEN BOLT		M6 x 35mm	PBY520KBHW	8 pcs
2	SPRING WASHER		M8		12 pcs
3	FLAT WASHER		M8 x 18mm		12 pcs
4	ALLEN KEY		M4		1 pc
5	PANHEAD		M4 x 30mm		4 pcs
6	ALLEN BOLT		M6 x 30mm		4 pcs
7	ADAPTER				1 pc

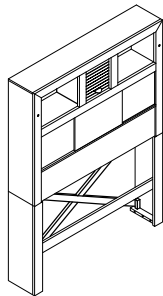

**COMPLETED HEADBOARD**

### BACK VIEW

**STEP 1:** Assembly the Headboard  
First attached the Headboard Leg L/R (B) to the Music Headboard (A) using Allen Key M4 (4) to tight Flat Washer (3), Spring Washer (2) and Allen Bolt (1). After that attached Headboard Stretcher (C) to Headboard Leg L/R (B). Using Allen Key M4 (4) to tight Flat Washer (3), Spring Washer (2) and Allen Bolt (6).

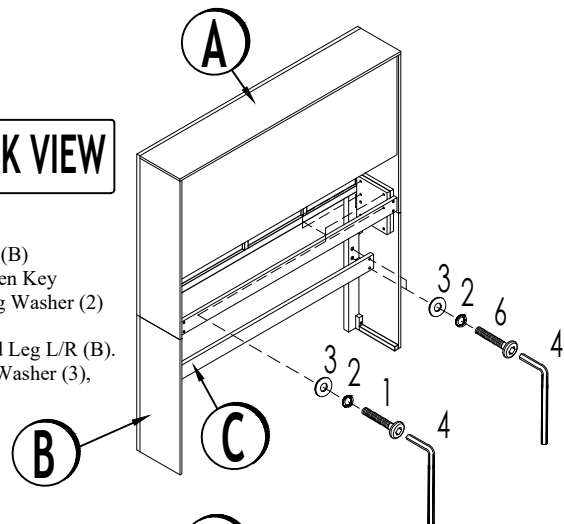

### BACK VIEW

**STEP 2:** Assembly the Back Support  
First attached the Headboard Stretcher X (D) to the Music Headboard (A) using Screw Driver to tight Panhead Screw (5).

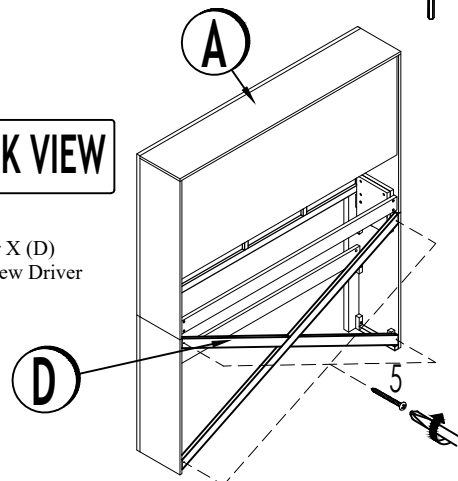









# ASSEMBLY INSTRUCTION FOR

## TWIN MUSIC BED BY520TH / BY520TF / BY520TFR BY720TH / BY720TF / BY720TFR

Caution: Please read instructions thoroughly before unpacking assembly parts. Sharp, exposed staple tips can cause injury, therefore, for your protection, please remove any exposed staples used in packing.

1. We recommend that you should assemble this product with the assistance of another person; this will make assembly easier, and will help to eliminate damage the product or injury to persons during assembly.
2. Be sure to check all packing materials carefully for small parts that may have come loose inside the carton during shipment.
3. Please do not over tighten screws or bolts.
4. Please put all parts on a non-abrasive floor before assembly, and follow the assembly steps to assemble your newly purchased product correctly and efficiently.

PART LIST				
NO.	PART DESC.	PART	CODE	QTY
A	HEADBOARD		BY520TH BY720TH	1 pc
B	FOOTBOARD		BY520TF BY720TF	1 pc
C	SIDE RAIL		BY520TFR BY720TFR	2 pcs
D	SLAT		PBY520TBSLT	4 pcs

HARDWARE LIST					
NO.	HARDWARE DESC.	PART	SIZE	CODE	QTY
1	ALLEN BOLT		M8 x 20mm	PBY520KBHW	8 pcs
2	FLAT WASHER		M8 x 18mm		8 pcs
3	ALLEN KEY		M5		1 pc
4	PANHEAD SCREW		M4 x 32mm		8 pcs
5	ADAPTER				1 pc

### STEP 5 : Plug in Adapter

Attach the Adapter (5) to plug, than connect to the Audio and LED cable behind of the Headboard (A).

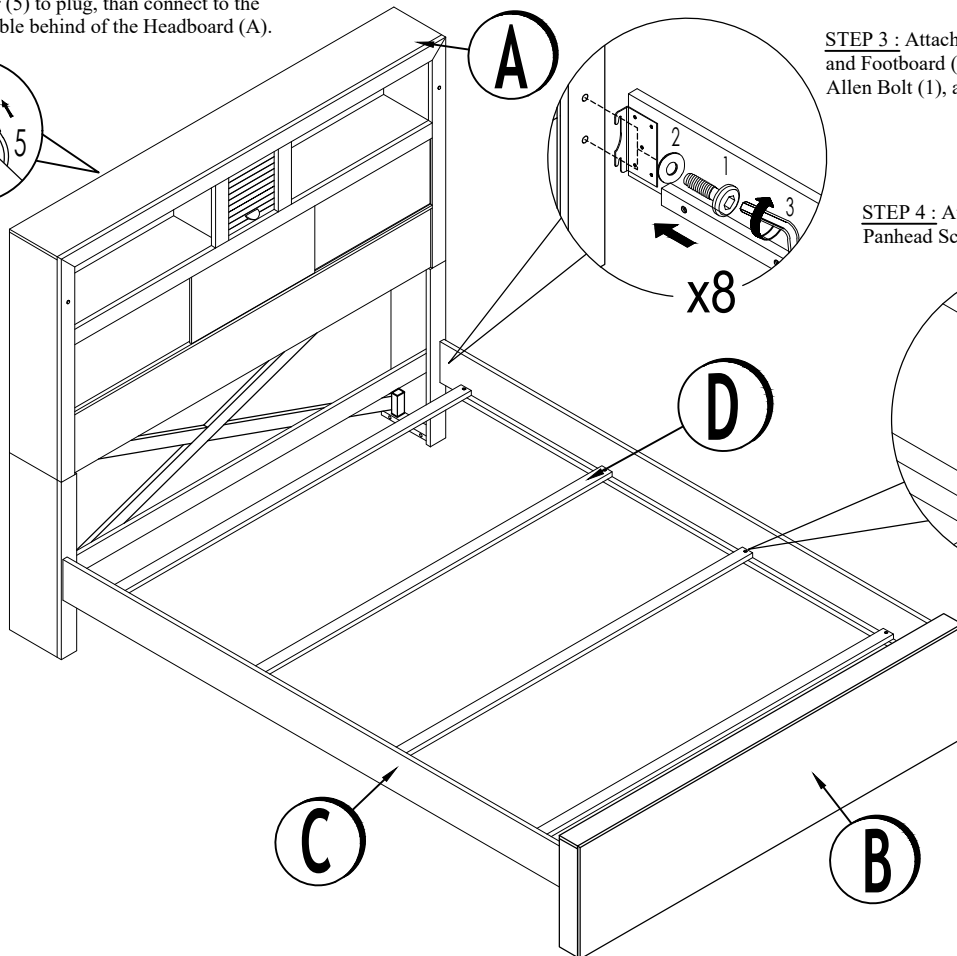
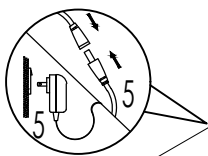

STEP 3 : Attached Side Rails (C) to Headboard (A) and Footboard (B) by using the Flat Washer (2), Allen Bolt (1), and tighten with Allen Key (3).

STEP 4 : Attached Slat (D) to Side Rail (C) Panhead Screw (4), and tighten with Screw Driver.

COMPLETED.