





ASSEMBLY INSTRUCTION FOR





QUEEN MUSIC BED

BY520QH / BY520QF / BY520QKR

Caution: Please read instructions thoroughly before unpacking assembly parts. Sharp, exposed staple tips can cause injury, therefore, for your protection, please remove any exposed staples used in packing.

1. We recommend that you should assemble this product with the assistance of another person; this will make assembly easier, and will help to eliminate damage the product or injury to persons during assembly.
2. Be sure to check all packing materials carefully for small parts that may have come loose inside the carton during shipment.
3. Please do not over tighten screws or bolts.
4. Please put all parts on a non-abrasive floor before assembly, and follow the assembly steps to assemble your newly purchased product correctly and efficiently.

PART LIST				
NO.	PART DESC.	PART	CODE	QTY
A	HEADBOARD PANEL		BY520QH	1 pc
B	HB - LEG (L / R)		PBY520HBLEG	2 pcs
C	HB - STRETCHER		PBY520QHSTR	1 pc
D	HB - STRETCHER X		BY520QH	1 pc

HARDWARE LIST					
NO.	HARDWARE DESC.	PART	SIZE	CODE	QTY
1	ALLEN BOLT		M6 x 35mm	PBY520KBHW	12 pcs
2	SPRING WASHER		M8		16 pcs
3	FLAT WASHER		M8 x 18mm		12 pcs
4	ALLEN KEY		M4		1 pc
5	PANHEAD		M4 x 30mm		4 pcs

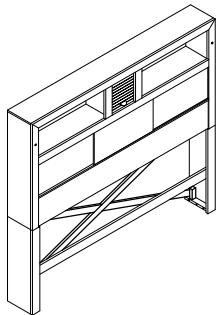

COMPLETED HEADBOARD

BACK VIEW

STEP 1: Assembly the Headboard
First attached the Headboard Leg L/R (B) to the Music Headboard (A) after that attached Headboard Stretcher (C) to Headboard Leg L/R (B). Using Allen Key M4 (4) to tight Flat Washer (3), Spring Washer (2) and Allen Bolt (1).

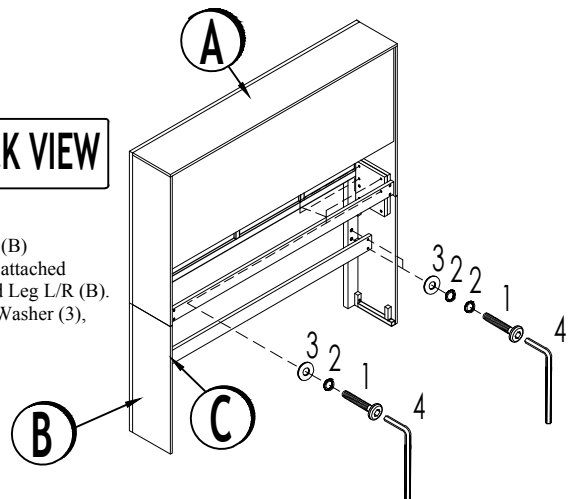

BACK VIEW

STEP 2: Assembly the Back Support
First attached the Back Support (D) to the Music Headboard (A) using Screw Driver to tight Panhead Screw (5).

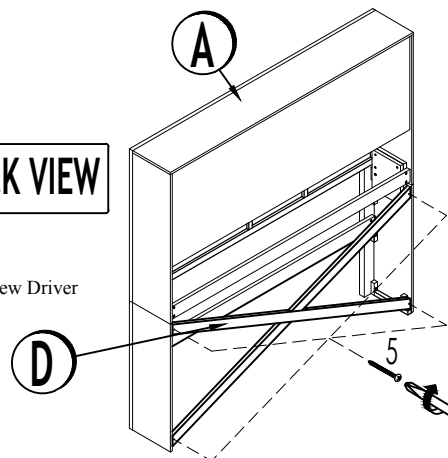





ASSEMBLY INSTRUCTION FOR





QUEEN MUSIC BED

BY520QH / BY520QF / BY520QKR

Caution: Please read instructions thoroughly before unpacking assembly parts. Sharp, exposed staple tips can cause injury, therefore, for your protection, please remove any exposed staples used in packing.

1. We recommend that you should assemble this product with the assistance of another person; this will make assembly easier, and will help to eliminate damage the product or injury to persons during assembly.
2. Be sure to check all packing materials carefully for small parts that may have come loose inside the carton during shipment.
3. Please do not over tighten screws or bolts.
4. Please put all parts on a non-abrasive floor before assembly, and follow the assembly steps to assemble your newly purchased product correctly and efficiently.

PART LIST				
NO.	PART DESC.	PART	CODE	QTY
A	HEADBOARD		BY520QH	1 pc
B	FOOTBOARD		BY520QF	1 pc
C	SIDE RAIL		BY520QKR	2 pcs
D	SLAT		PBY520QBSLT	4 pcs
E	VERTICAL LEG		PBY520BDSPL	4 pcs

HARDWARE LIST					
NO.	HARDWARE DESC.	PART	SIZE	CODE	QTY
1	ALLEN BOLT		M8 x 20mm	PBY520KBHW	8 pcs
2	FLAT WASHER		M8 x 18mm		8 pcs
3	ALLEN KEY		M5		1 pc
4	PANHEAD SCREW		M4 x 32mm		8 pcs

