

Assembly Instruction For QUEEN PANEL BED

B.4823.QHFE / B.4823.QRE /
B.4825.QHFE / B.4825.QRE













Caution: Please read instructions thoroughly before unpacking assembly parts. Sharp, exposed staple tips can cause injury, therefore, for your protection, please remove any exposed staples used in packing.

1. We recommend that you should assemble this product with the assistance of another person; this will make assembly easier, and will help to eliminate damage to the product or injury to persons during assembly.
2. Be sure to check all packing materials carefully for small parts that may have come loose inside the carton during shipment.
3. Please do not over tighten screws or bolts.
4. Please put all parts on a non-abrasive floor before assembly, and follow the assembly steps to assemble your newly purchased product correctly and efficiently.

PART LIST

Part	Part Desc.	Code	Qty
1	Headboard Panel	PB.4823.HBPNL / PB.4825.HBPNL	1
2	Headboard Bottom Panel	PB.4823.HBBPN / PB.4825.HBBPN	1
3	Footboard Panel	PB.4823.FBPNL / PB.4825.FBPNL	1
4	Side Rail	PB.4823.QBSR / PB.4825.QBSR	2
6	Headboard & Footboard Cap Rail	PB.4823.BDCAP / PB.4825.BDCAP	2
7	Headboard Leg (Left)	PB.4823.HBLEG / PB.4825.HBLEG	1
8	Headboard Leg (Right)		1
9	Footboard Leg (Left)	PB.4823.FBLEG / PB.4825.FBLEG	1
10	Footboard Leg (Right)		1
11	Slat Support Leg with Leveler	PB.4823.BDSPL / PB.4825.BDSPL	3
12	Center Slat Support Rail	PB.4823.QBSTL2 / PB.4825.QBSTL2	1
13	Roll Slat	PB.4823.QBSTL1 / PB.4825.QBSTL1	2 Sets

HARDWARE LIST

Part	Hardware Desc.	Code	Qty
A	 CAM NUT 10mm	PB.4823.QBHW / PB.4825.QBHW	6
B	 CAM BOLT		6
C	 WOOD DOWEL M8 x 30mm		24
D	 JCBC SCREW M6 x 90mm		20
E	 BARREL NUT M6		20
F	 CSK SCREW M4 x 65mm		6
G	 CSK SCREW M4 x 38mm		16
H	 CSK SCREW M3.5 x 16mm		16
I	 ALLEN KEY		1
J	 SLAT BRACKET HC 021		2
K	 PVC NAIL 5/8"		4
L	 M6 x 20mm GLIDER		3

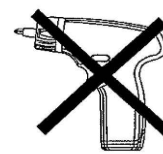
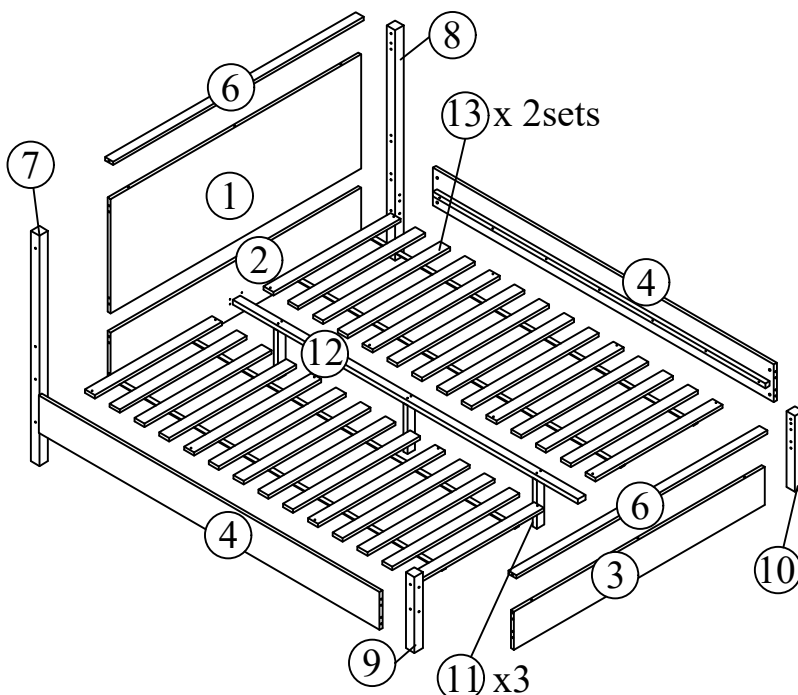

**** WARNING: THE USE OF POWER TOOLS TO ASSEMBLE THIS PRODUCT WILL INVALIDATE ANY CLAIM AND MAY DAMAGE THIS PRODUCT MAKING IT UNSAFE.**

** You will need a screwdriver and a small mallet (NOT provided)

Tools You Need:



Philips Head Screwdriver

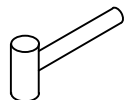

Soft Head Mallet

Assembly Instruction For QUEEN PANEL BED

B.4823.QHFE / B.4823.QRE /
B.4825.QHFE / B.4825.QRE

STEP 1:

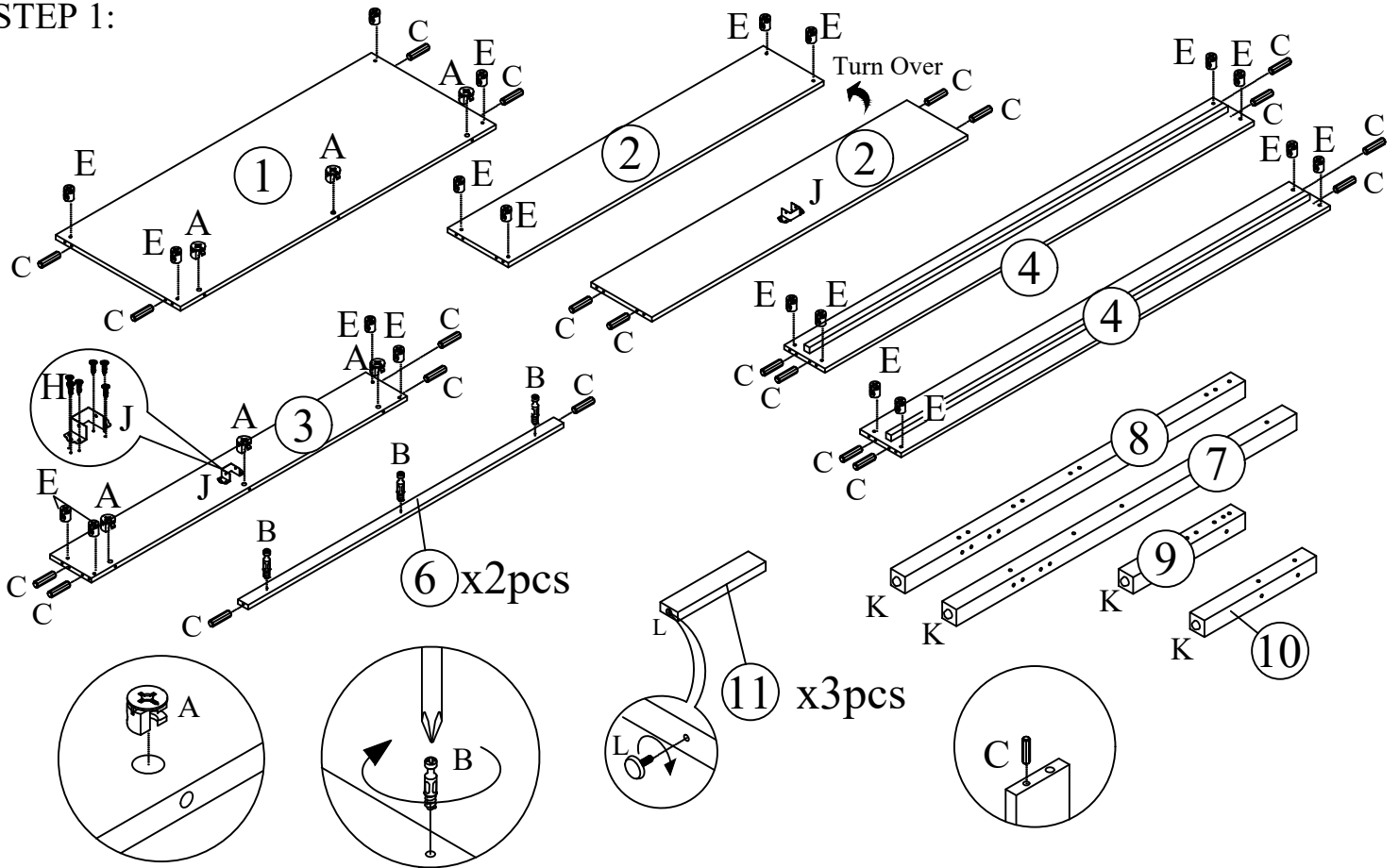

STEP 2:

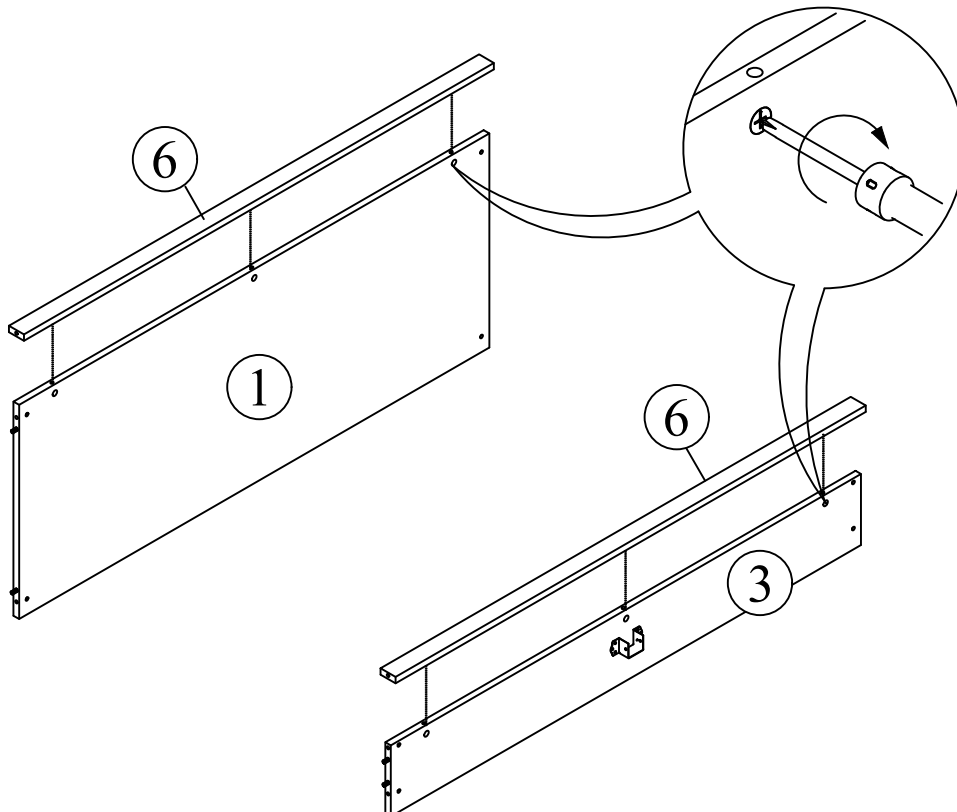

Assembly Instruction For QUEEN PANEL BED

B.4823.QHFE / B.4823.QRE /
B.4825.QHFE / B.4825.QRE

STEP 3:

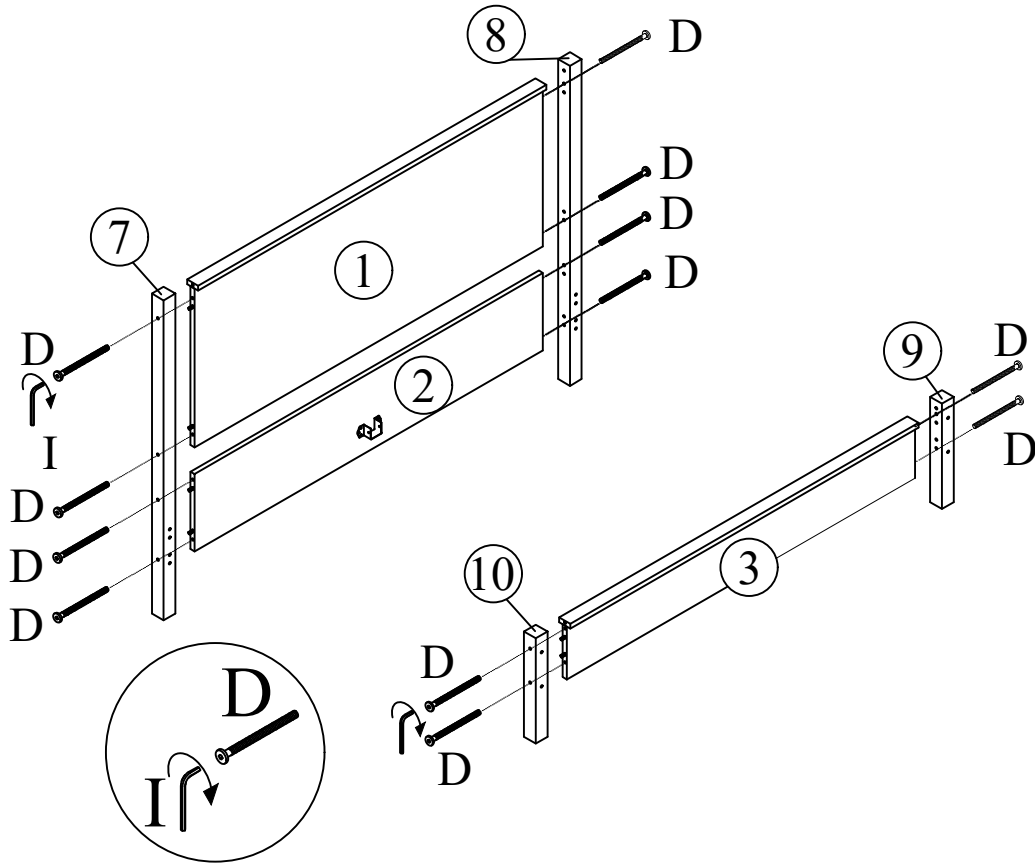

STEP 4:

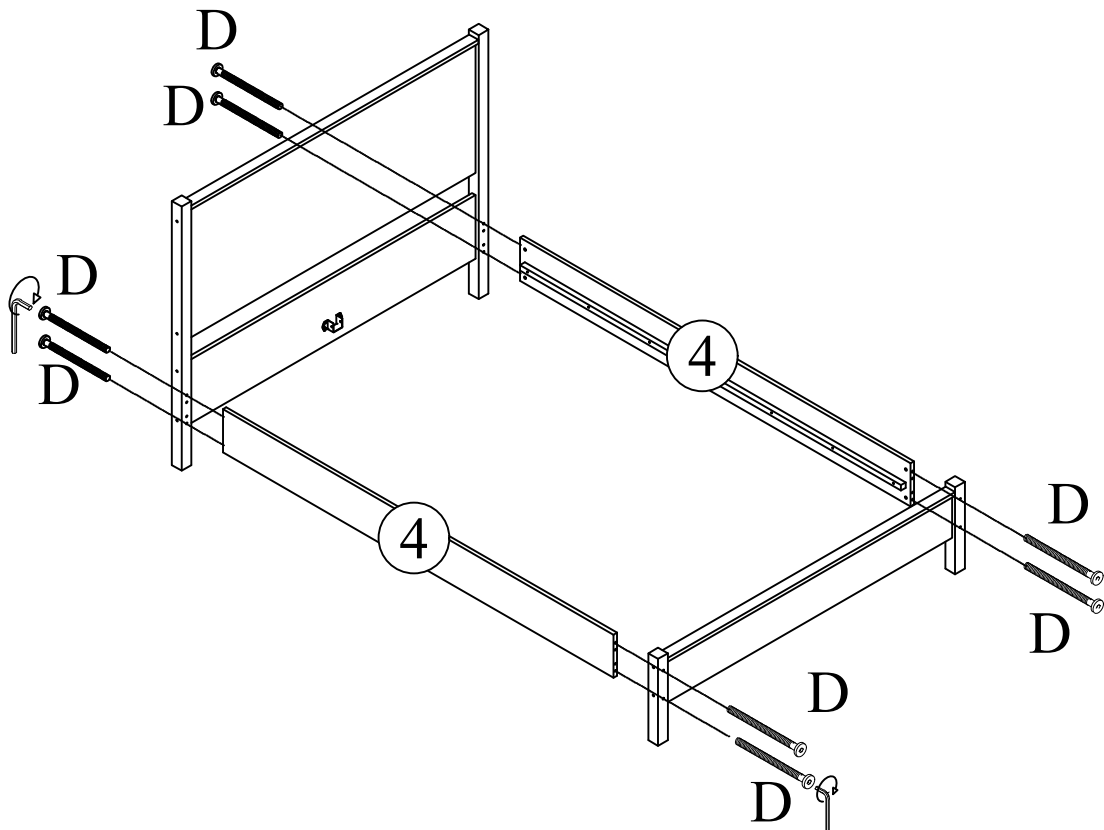

Assembly Instruction For QUEEN PANEL BED

B.4823.QHFE / B.4823.QRE /
B.4825.QHFE / B.4825.QRE

STEP 5:

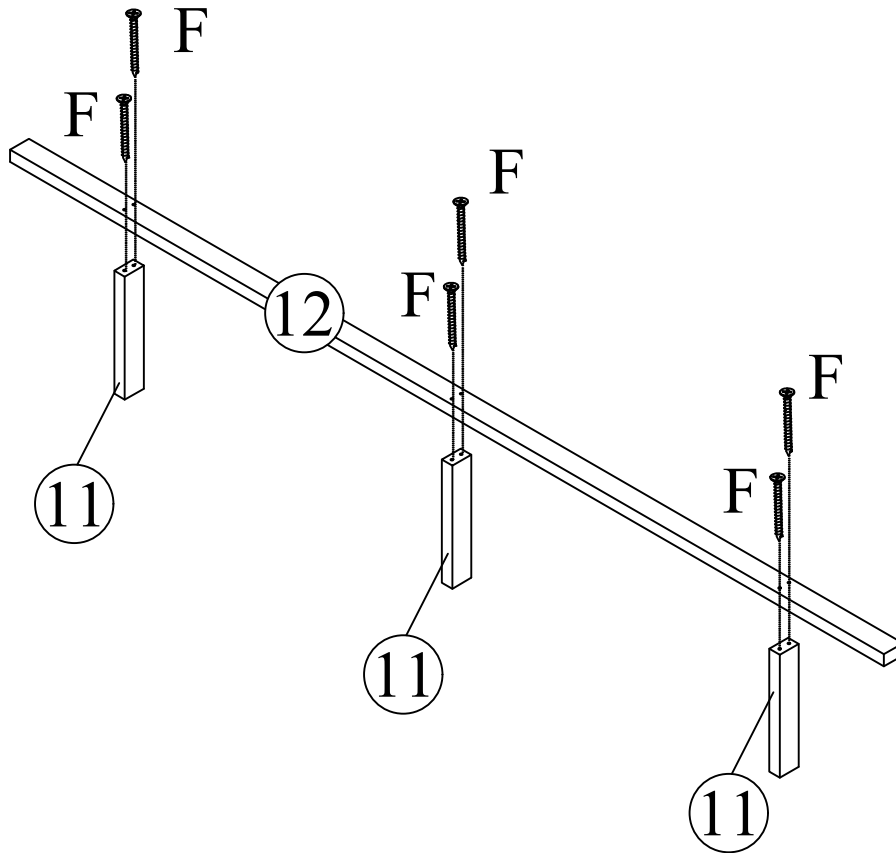

STEP 6:

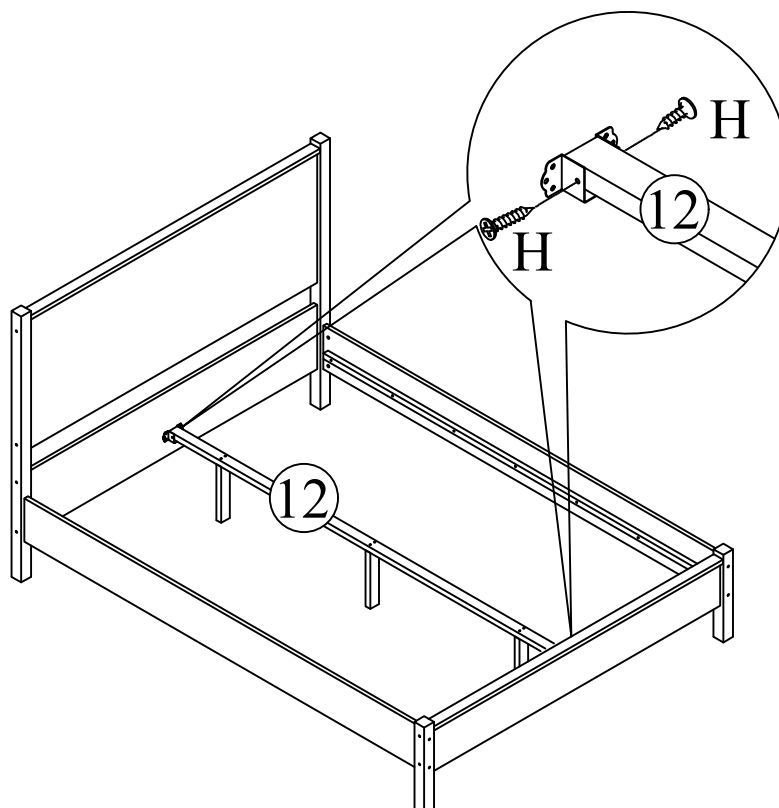

Assembly Instruction For QUEEN PANEL BED

B.4823.QHFE / B.4823.QRE /
B.4825.QHFE / B.4825.QRE

STEP 7:

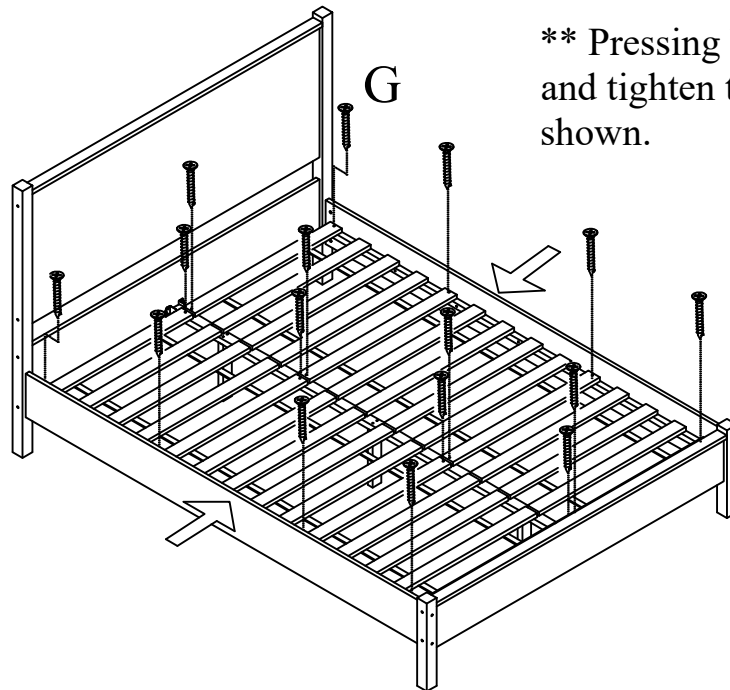

COMPLETE

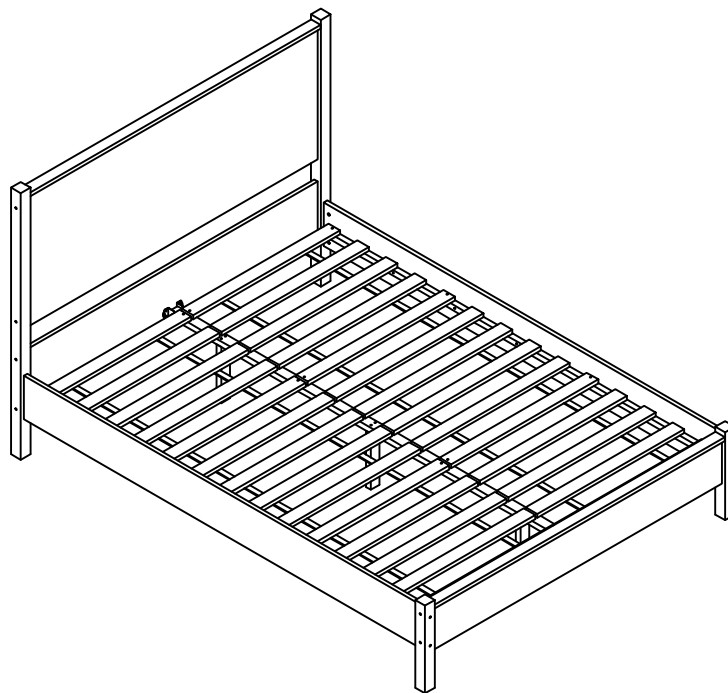

WARNING: To avoid serious personal injury:

- Carefully and strictly follow assembly instructions. Improper assembly of furniture can result in structural failure, instability of the product, or tip-over.
- Monitor and carefully control the assembly components. These include small parts and hardware that may present a choking hazard to small children.
Furniture should be assembled only by responsible adults and children should not be involved in the assembly process.
- Where provided, wall mounting hardware should always be used as prescribed in these instructions to anchor furniture to wall. Proper use of the wall mounting hardware can significantly reduce the potential for furniture tip-over and crushing injuries.