





Thank you for purchasing this quality product. Be sure to check all packing material carefully for small parts that may have come loose inside the carton during shipment

Key Parts			
No	Code	Qty	Description
1	1706-14KDP41	1 pc	Bench Seat
2	1706-14KDP42	4 pcs	Bench Corner Leg
3	1706-14KDP42M	2 pc	Bench Middle Leg
4	1706-14KDP01F	4 pcs	Floor Glide
5	1706-14KDP01L	2 pcs	Floor Leveler

Hardware kit (1706-14KDP46)			
No		Description	Q'Ty
A		Hexa Nut Ø8	12 pcs
B		Lock Washer Ø8.5	12 pcs
C		Flat Washer Ø8.5	12 pcs
D		Key Wrench	1 pc

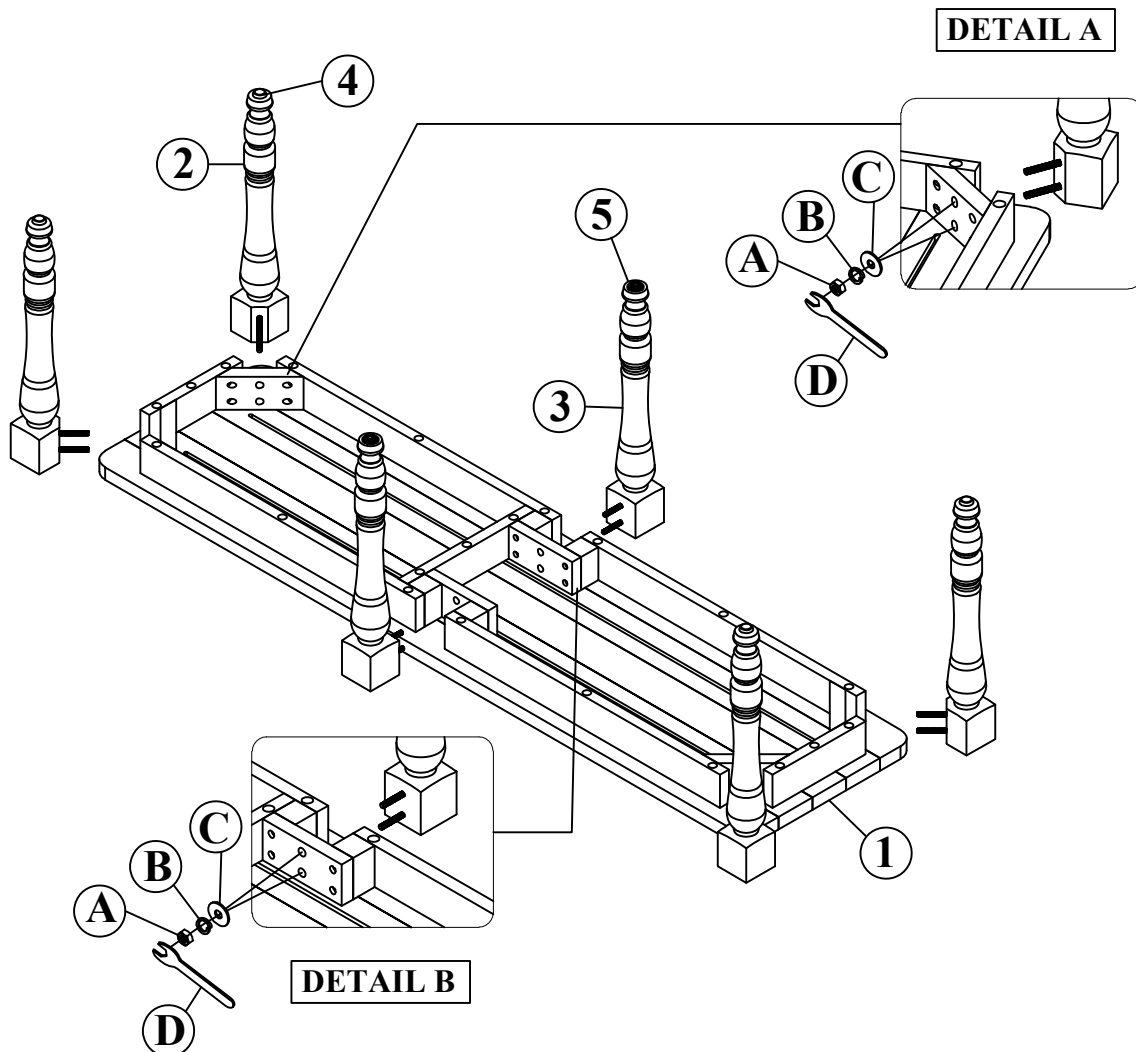

STEP 1

- Carefully lay Bench Seat upside down on a smooth flat surface to prevent scratches.
- Affix each Leg to each corner of the Bench Seat as shown in illustration. Insert a Flat Washer, Lock Washer and Nut on the bolts of each Leg (See Detail A)
- Attach the middle leg into link beetle of the Bench Seat as shown in illustration. Insert a Flat Washer, Lock Washer and Nut on the bolts of middle leg (See Detail B) and adjusting the leg leveler to meet the floor.
- Once all Legs are in place, fully tighten nuts by turning clokwise using provided Key Wrench until secure.