

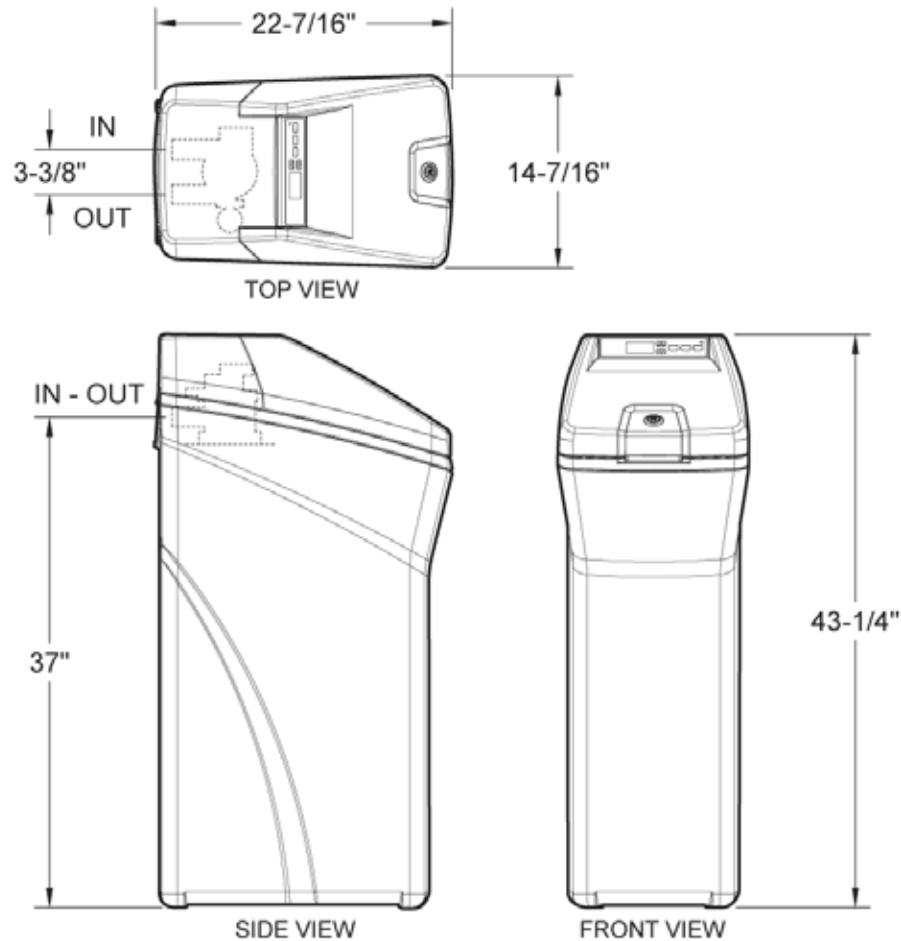

GE Appliances

GXSF30V – GE SmartWater™ Water Softener



Salt Capacity – 200 lbs.

Important: All units must be installed according to local codes.

Note: Before installing, consult installation instructions packed with product for current dimensional data.



GXSF30V conforms to ANSI/NSF 44 for specifically claimed performance.

Above illustration intended for dimensional reference only. Refer to photograph for actual product appearance.

Specification Created 12/11
380231

For answers to your Monogram® GE Profile™ or GE appliance questions, visit our website at GEAppliances.com or call GE Answer Center® service, 800.626.2000.



GE Appliances

GXSF30V – GE SmartWater™ Water Softener

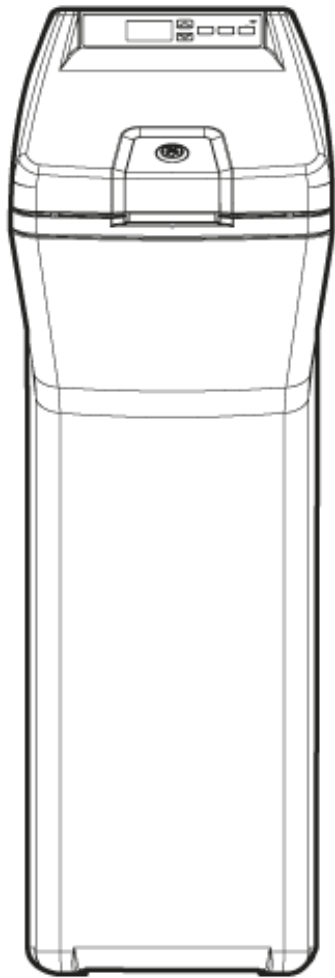

Features and Benefits

- Easy to use up-front electronic controls with status light indicator
 - 30,200 Grain Capacity
 - Efficiency (5100 gpg)
 - Maximum Hardness Removal (95gpg) / Maximum Iron Removal (7ppm)
 - Salt Capacity (200 lbs)
 - GE Exclusive SmartSoft™ Technology ensures there is always plenty of softened water available by "learning" a family's water-use patterns.
 - GE Exclusive Days to Empty makes sure you never have to guess when to refill the salt tank
 - Uses up to 20% less water*
 - Plumbing connection up to 1"
- *Based on internal analysis. Verses GE water softeners manufactured prior to 2009
- Model GXSF30V

**Specification Created 12/11
380231**