



User Manual / Installation Instructions

Outdoor Gooseneck Pull Down Faucet (LPFK)

IMPORTANT SAFETY INSTRUCTIONS

CAUTION: Ensure all water lines to the faucet are shut down before beginning any work. Make sure you READ and UNDERSTAND these instructions BEFORE installation. If you have any questions or concerns prior to, or during service, please call Customer Care/ Tech. Support at 888-289-5969, Mon.– Fri. 6AM to 4:30PM, and Saturdays from 8AM to 1PM Pacific Time.

This product is designed for indoor or outdoor installation. Improper installation, adjustment, alteration, service or maintenance can cause personal or property damage and may void the warranty. Read this manual thoroughly before installation, use or service.

Philips head screwdriver, a small rag and gloves are recommended.



IF SHIPMENT ARRIVED DAMAGED:

1. **VISIBLE LOSS OR DAMAGE:** Be certain this is noted on freight bill or express receipt and signed by person making the delivery.
2. **FILE CLAIM FOR DAMAGES IMMEDIATELY,** regardless of extent of damage.
3. **CONCEALED LOSS OR DAMAGE:** If damage is unnoticed until merchandise is unpacked, notify transportation company or carrier immediately and file a “concealed damage” claim with them. This should be done within (15) days of date delivery is made to you. Be sure to retain container for inspection. We cannot assume responsibility for damage or loss incurred in transit.

Replacement Parts LPFK

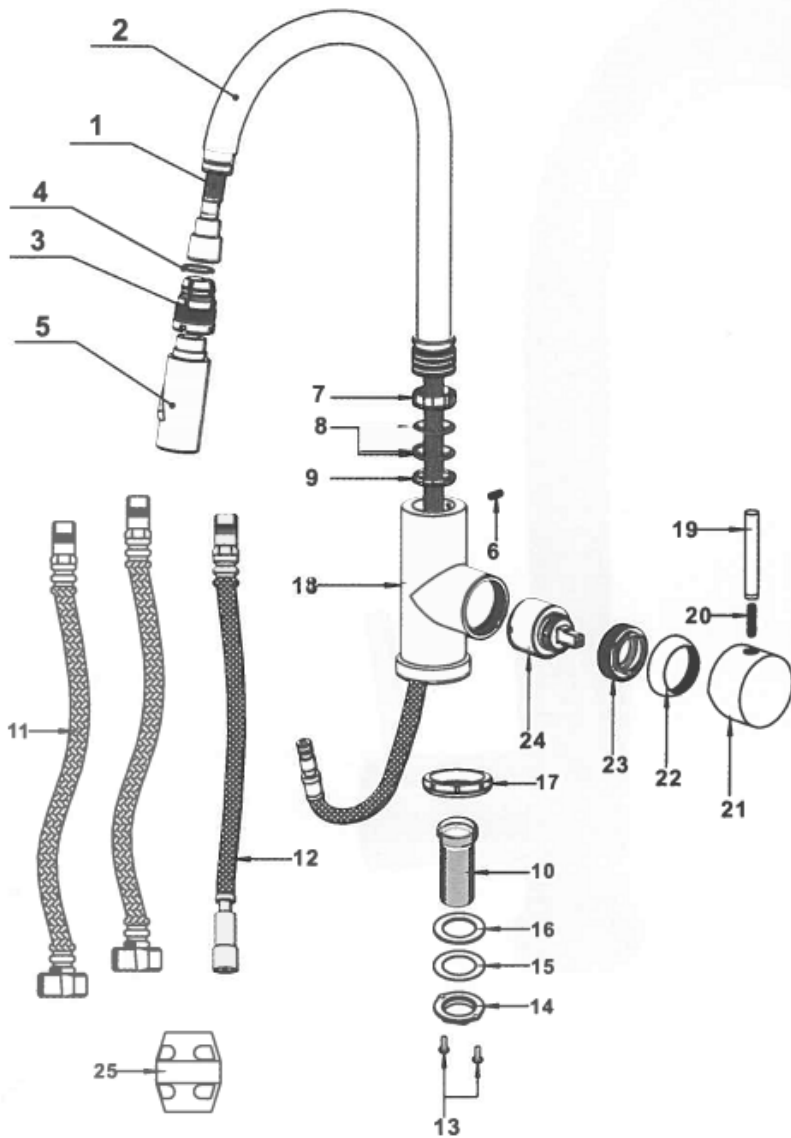

- 1 Hose
- 2 Spout
- 3 Plastic cover
- 4 O-ring
- 5 Sprayer
- 6 Set screw
- 7 Sleeve
- 8 O-rings
- 9 Sleeve
- 10 Extension pipe
- 11 Hot & cold water lines
- 12 Quick-connection hose
- 13 Screws
- 14 Locking nut
- 15 Metal washer
- 16 Rubber washer
- 17 Rubber washer
- 18 Faucet body
- 19 Handle lever
- 20 Set screw
- 21 Handle body
- 22 Cartridge cover
- 23 Locking nut
- 24 Cartridge
- 25 Weight

Product Dimension Drawing LPFK

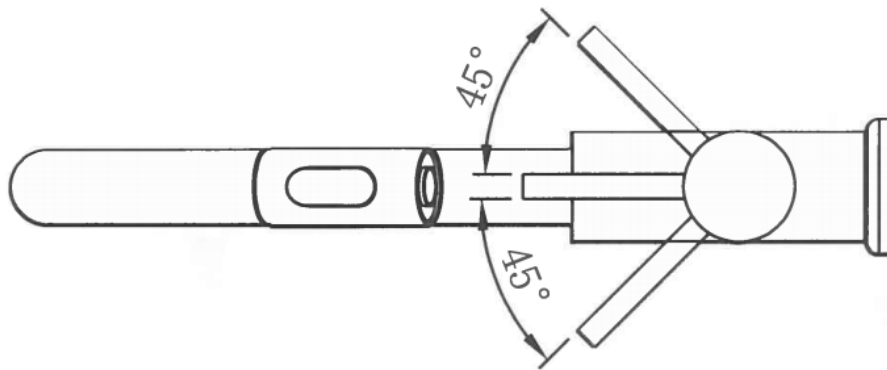
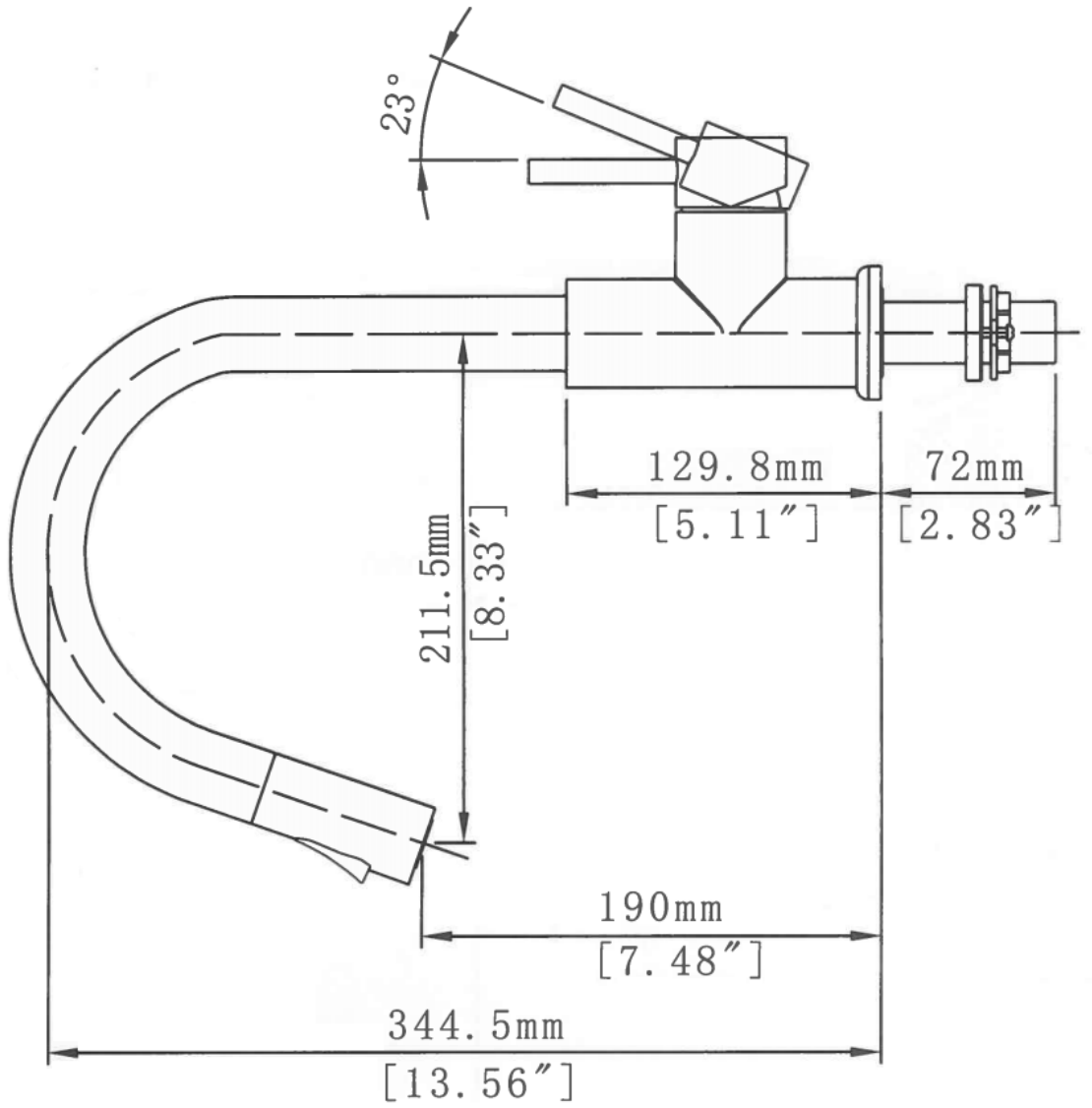

Faucet Installation Procedures LPFK

Prior to installation:

Make sure all pre-installed lines (parts#11-12) are tightly screwed into the faucet.

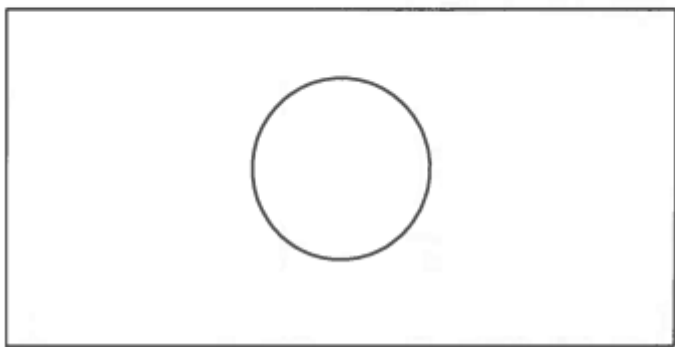
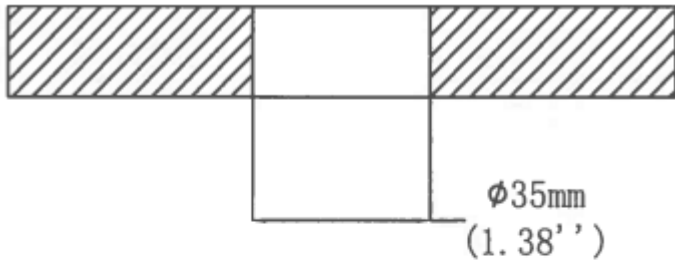

Step ①

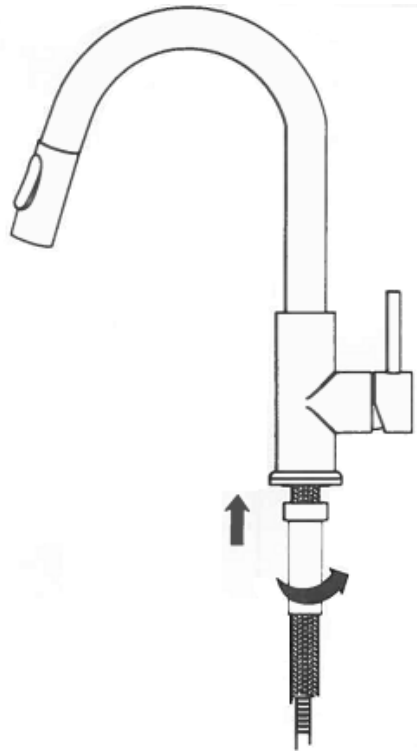

Step ②

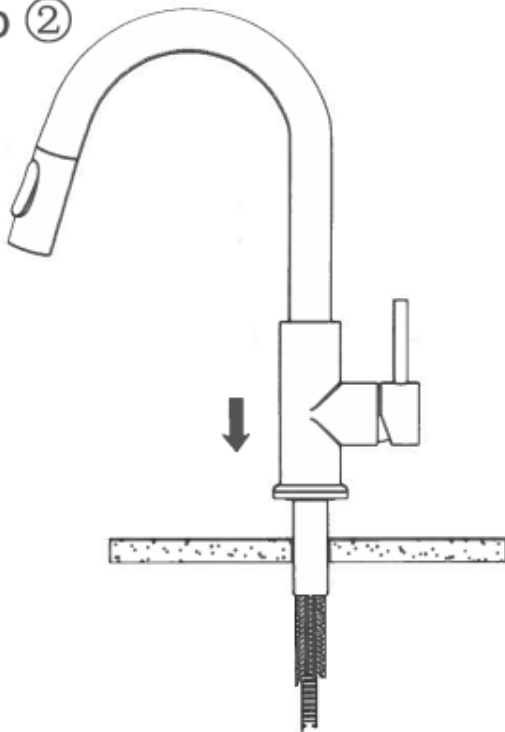

Step ③

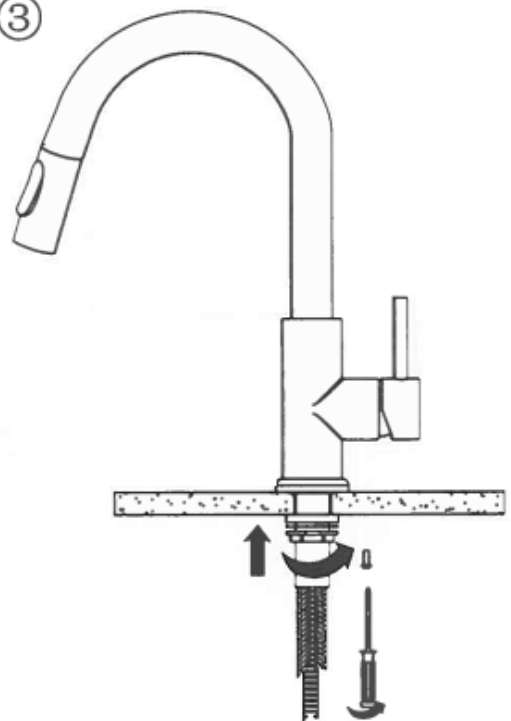

Faucet Installation Procedures LPFK

Step ④ Important

Run water out of Hot and Cold angle valves to flush debris before connecting the water supply lines(#11).Place a bucket under the valve. When valve is turned on water will shoot up . Cup over the valve opening so water will fall into the bucket.

Make sure O-ring is in the end of the preinstalled Hot and Cold water lines and the lines are tightened.

Connect Hot & Cold water lines to angle valves. Tighten securely, but do not overtighten.

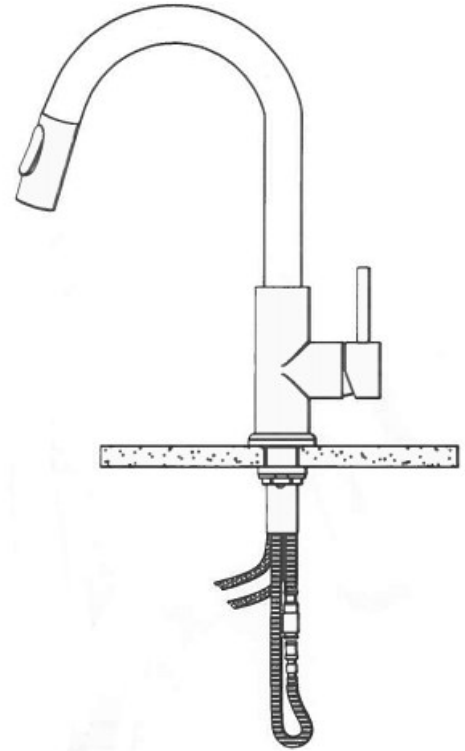
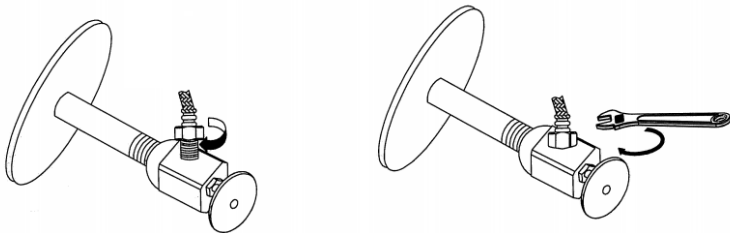

Connect spray hose to quick-connection hose until you hear "click". The tip of the quick-connection should spring back to original position. Test by pulling both ends to make sure they do not separate.

Step ⑤

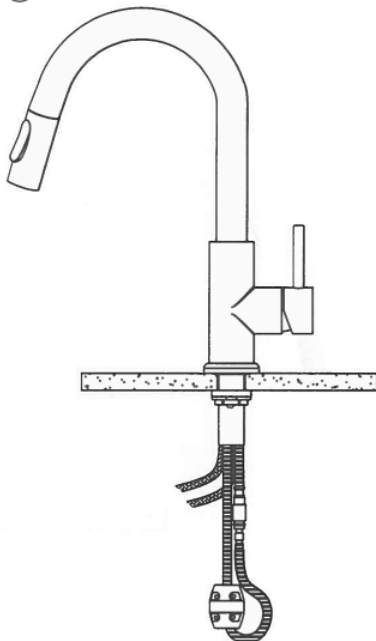

Install weight (part #25) at the lowest point on the pull out hose (part #1) as shown on diagram. Tighten screws on weight with Phillips screwdriver.

Faucet Installation Procedures LPFK

Step ⑥

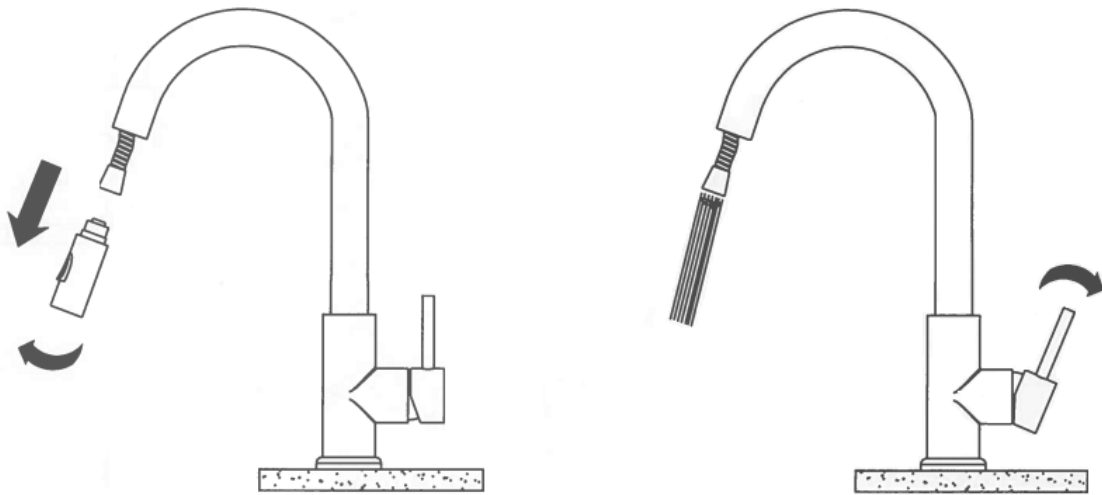

Step ⑦

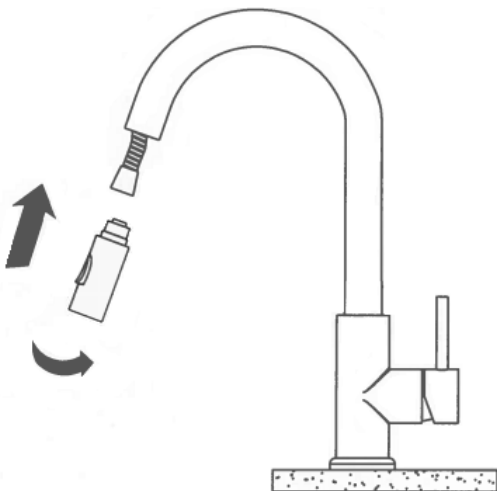

Step ⑧

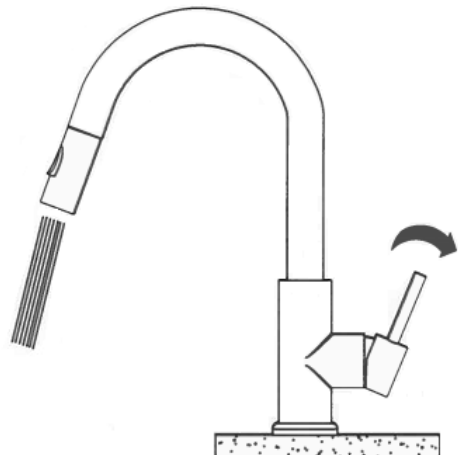



Important notice: Please lubricate all O-rings and washers with water prior to installation and do not over tighten the connectors.

Lynx Professional Faucet Ten Year Limited Warranty

Lynx Grills, Inc. warrants its Professional Series Faucet to be free of manufacturing defects in materials and workmanship during normal residential outdoor use for ten years for the original date of purchase. This warranty applies only to Lynx Grills, Inc. Professional Series Faucets installed in the United States or Canada.

Lynx Grills, Inc. also warrants all other aspects of the Professional Series Faucet to be free of defects in material and workmanship during normal outdoor residential use for the shorter of ten years or as long as the original purchaser owns his or her home. If a defect is found in normal outdoor residential use within ten years of purchase, Lynx Grills, Inc. will, at its sole discretion, repair, provide a replacement part or product, or make appropriate adjustment. Damage to the Faucet caused by accident, misuse, abuser, or acts of God are not covered by this warranty. Improper care or cleaning with caustic or abrasive materials will void the warranty. Commercial or marine applications are not covered by this warranty. Proof of purchase in the form of the original sales receipt must be provided to Lynx Grills, Inc. with all warranty claims. After ten years from the original purchase date, if the Faucet is in need of repair or replacement, the customer will be responsible for the cost and shipping of parts or product. Lynx Grills, Inc. is not responsible for labor charges, installation, or other incidental or consequential costs. In no event shall the liability of Lynx Grills, Inc. exceed the retail purchase price of the Faucet. For more information visit our website at www.lynxgrills.com, or contact our Customer Care Group at 1.888.289.5969



PROFESSIONAL GRILLS

The Lynx Story...

Lynx began as the vision of a group of people with over a century of collective experience, who for 35 years were manufacturing top-of-the-line stainless steel products for the commercial food service industry. Lynx has taken that same quality, workmanship, service and innovation and incorporated it into the Lynx Professional Grills line of products. The combination of the best materials, fine craftsmanship and original ideas is why Lynx products are in a class of their own.

These original commercial products are found in restaurants, hotels and theme parks across the USA:

- TGI Fridays • Applebee's • Houston's • Red Lobster
 - Hard Rock Café • Wolfgang Puck's • Cheesecake Factory • Red Robin • Planet Hollywood • Hilton • Hyatt • Four Seasons Marriott Le Meridian • Sheraton
 - Conrad International Bellagio • New York New York • MGM Grand • Treasure Island • Mirage • Paris
 - Venetian • Excalibur • Manadalay Bay • Riviera
 - Desert Inn • Hard Rock Hotel • Disney World
-

Questions? Talk to your Lynx Authorized Dealer or visit our website at www.lynxgrills.com

Lynx Grills, Inc., 7300 Flores Street, Downey CA 90242, Customer Care: 888-289-5969



The best outdoor kitchen products come from:

*Lynx Grills, Inc.
7300 Flores Street
Downey, CA 90242*

*For more information please call,
1-888-289-5969 or visit www.lynxgrills.com*

2016 ©Lynx Grills

As product improvement is an ongoing process at Lynx, we reserve the right to change specifications and design without notice.