

# THE ASHTON CANOPY

## Data Sheet

The Ashton is a high quality, fully aluminium canopy with a big span of up to 6m between posts and a maximum projection of 6m. It is a wall mounted structure as standard however, it can also be supplied as a freestanding canopy.



0800 389 9072

[www.ablecanopies.co.uk](http://www.ablecanopies.co.uk)  
[sales@ablecanopies.co.uk](mailto:sales@ablecanopies.co.uk)

### Dimensions:

Length:	Unlimited
Width/Projection:	Up to 6 metres
Height:	To your specification, 2.5° - 45° pitch
Spacing Between Posts:	Up to 6 metres

### Features:

Wall Mounted or Free Standing:	Available as both
Suitable for:	Education   Hospitality   Leisure   Retail   Commercial   Healthcare   Residential
Guarantee:	10 Years*
Life Expectancy:	Up to 25 Years
Maintenance:	Requires only periodic cleaning
Installation Type:	Permanent
Retractable/Collapsible:	No
Method of Fixing:	Posts are installed into the ground with 600mm x 600mm x 600mm pad stones.

### Frame Specifications:

Construction Material:	T6 Grade aluminium
Wall Plate:	Extruded aluminium profile which fixes to the building directly. You can also use a steel bespoke bracket or rear steel goal post frame when this is not possible
Guttering:	Integrated aluminium guttering with uPVC /aluminium downpipes
Frame Finish:	Powder Coated
Colour Options:	Supplied in Anthracite Grey (RAL 7016) as standard, available in any other RAL colour at an additional cost
Fixings:	316 marine grade stainless steel fixings

### Roof Specifications:

Roof Frame:	Constructed from T6 grade structural aluminium
Roof Covering:	8mm toughened glass
Strength:	Glass: toughened during manufacturing to achieve Class 1 BS EN 12600 for impact performance
Colour Options:	Glass: Clear or a blue tint













*\*The Ashton wall mounted canopy is an aluminium structure however, the Ashton free standing canopy is available with a choice of aluminium or steel rear posts, the steel posts will not be covered by the 10 year guarantee.*

## International Standards:

**Strength Tests:** Glass panels: Toughened to achieve Class 1 BS EN 12600 for impact performance

**CE Marked** Yes to UKCA BS EN1090-1:2009+A1:2011

## Colour Options:

	Standard Colours	Non Standard Colours (Additional costs may apply)
<b>Framework</b>	 9005	Available in any RAL colour, standard colours are shown below:  9910  3000  1023  6018  6005  9005  7016  7012  7001  5015  5005
<b>Glass Roof Covering</b>	 Clear Opal	 Clear

## Weather Protection:



## Available Upgrades:

Post Pads	✓
Signage	✓
Glass Side & Front Fills	✓
Tensile Fabric Side Panels	✗
Rainbow Package	✗
Roller Shutters	✗
Coloured Polycarbonate	✗

## Technical Files Available:

PDF CAD File	✓
DXF CAD File	✓
IGES CAD File	✓
STL CAD File	✓
BIM File	✓
NBS Spec	✓

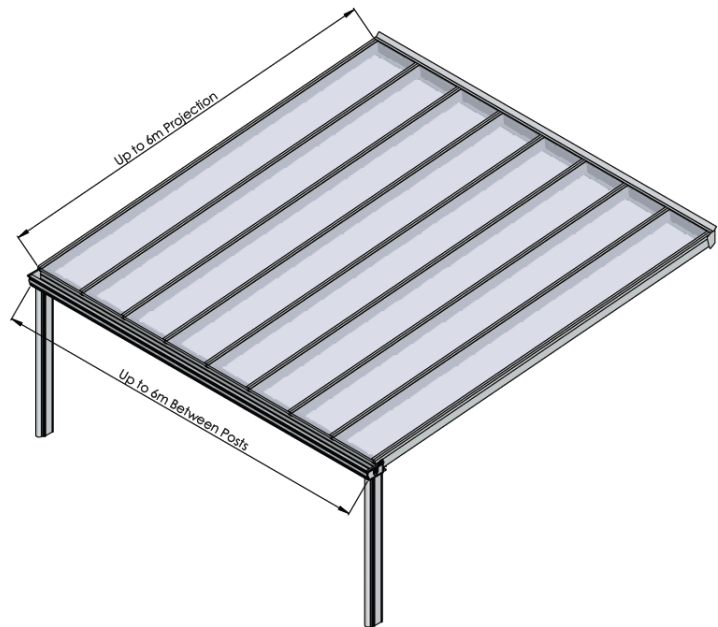

Base & Post Connection Information

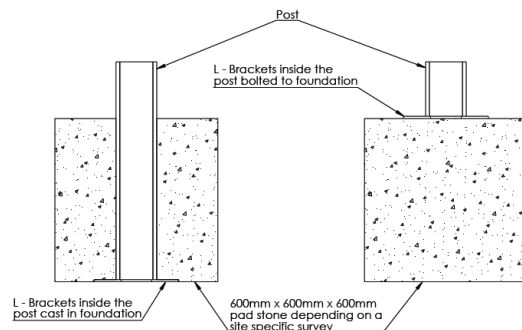

0800 389 9072 | [www.ablecanopies.co.uk](http://www.ablecanopies.co.uk) | [sales@ablecanopies.co.uk](mailto:sales@ablecanopies.co.uk)

Head Office | 9 - 11 Faraday Close, Gorse Lane Industrial Estate, Clacton-on-Sea, Essex CO15 4TR



Able Canopies Ltd. is a private Limited Company registered in England with registration number 5391477.

0800 389 9072 | [www.ablecanopies.co.uk](http://www.ablecanopies.co.uk) | [sales@ablecanopies.co.uk](mailto:sales@ablecanopies.co.uk)