

rev 1.2

DATA SHEET
HWG HYDRAULIC WELDING GENERATOR



HWG 400/10K-79

DIMENSIONS

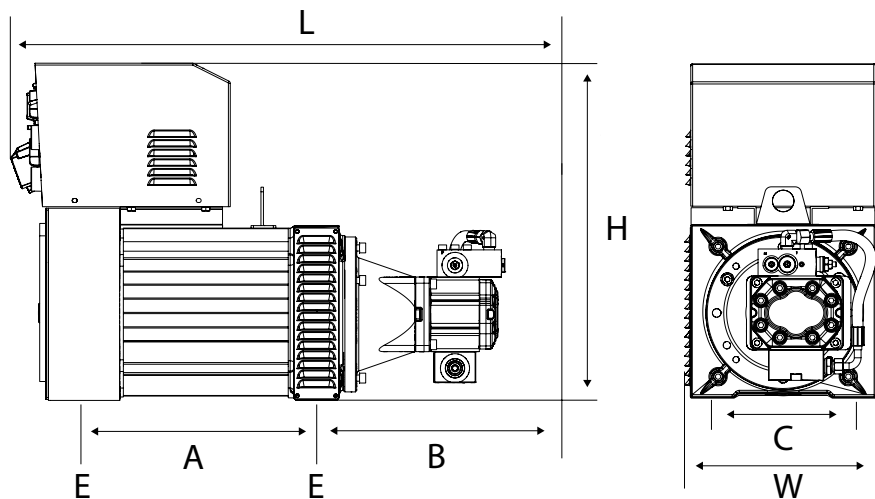

MODEL	DIMENSIONS, mm (in)							WEIGHT
	L	W	H	A	B	C	E	kg (lbs)
HWG400/10K-79	801 (31.55)	318 (12.55)	544 (21.45)	382 (15.0)	308 (12.1)	220 (8.7)	Ø14 (0.6)	132 (291)

HYDRAULIC PORTS

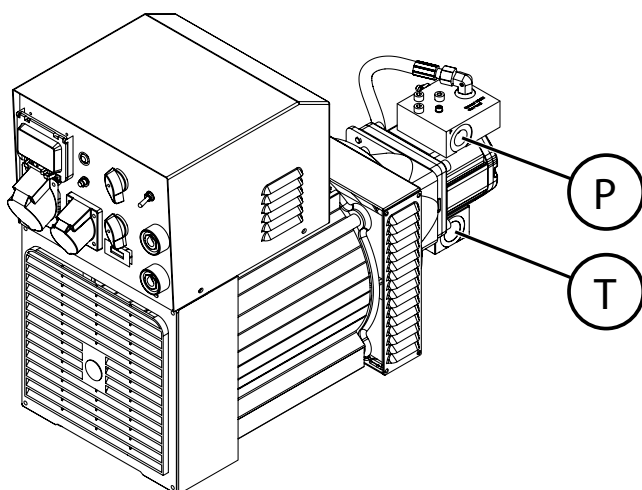

MODEL	PRESSURE LINE	RETURN LINE
HWG400/10K-79	P BSB 3/4"	T BSB 1"

TECHNICAL SPECIFICATIONS

		HWG400/10K-79
OUTPUT CHARACTERISTICS		
Welding current	ADC	30-400 ADV
Welding electrode		Ø 7 mm
Welding current adjustment		Selector switch 10 - 100%
Load duty	ED	35% / 400 A
Arc striking voltage	VDC	70 VDC
Welding voltage	VDC	22 - 36
Welding cables	mm²/m	35 mm ² / 5m
AUXILIARY ELECTRICITY		
1-phase*		230 VAC / 4,0 kVA
3-phase		400 VAC / 10,0 kVA
Socket 2P+PE	16A	1 pcs
Socket 3P+N+PE	16A	1 pcs
IP class		23
HYDRAULIC POWER REQUIREMENTS		
Flow min.	l/min (gpm)	81 (21.4)
Flow max.	l/min (gpm)	101 (26.7)
Pressure at nominal power output	bar (psi)	200 (2900)
Pressure max.	bar (psi)	210 (3000)
HYDRAULIC FLUID REQUIREMENTS		
Viscosity	cSt	10-200 / optimum 25-35
Temperature	°C (°F)	max. 70 (158)**
Filter ratio	um	25 or better
Cooling capacity requirements	kW	3

Gallons are U.S. liquid gallons

* Nominal current 1~phase / 3~phase /phase must not exceed maximum load

** Depending on the hydraulic fluid.

Other options available by request.



Menotie 3
FI-33470 Ylöjärvi, Finland
tel: +358 3 3488 200
info@dynaset.com



ELECTRICITY

HG Hydraulic Generator
HGV Variable Hydraulic Generator
HWG Hydraulic Welding Generator
HGG Hydraulic Ground Power Generator



MAGNET POWER

HMG Hydraulic Magnet Generator
HMAG Hydraulic Magnet
MAG Lift Magnet



HIGH PRESSURE WATER

HPW Hydraulic High Pressure Water Pump
HPW Hydraulic Power Washer
KPL High Pressure Street Washing Unit
PPL High Pressure Pipe Cleaning Unit
HPW-DUST High Pressure Dust Suppression System
HPW-FIRE High Pressure Firefighting System
FP Fire Fighting Piercing Kit
HDF Hydraulic Drilling Fluid Pump
JPL High Pressure Bin Washing System
HSP Hydraulic Submersible Pump



VIBRATION

HVB Hydraulic Vibra
HVD Hydraulic Directional Vibra



POWER BOOSTING

HPI Hydraulic Pressure Intensifier
HPI-C Hydraulic Pressure Intensifier for Cylinder



COMPRESSED AIR

HK Hydraulic Compressor (piston)
HKL Hydraulic Rotary Vane Compressor
HKR Hydraulic Screw Compressor



KNOW-HOW

HHK Hydraulic Grinder
HV/HVY Hydraulic Winch / Winch Unit
Hydraulic Power Take-off (PTO)
Hydraulic Power Unit Technology
De-Icing Technology
Installation Valves

www.dynaset.com

