

ASSEMBLY 1

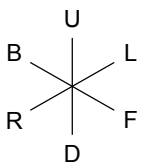

ASSEMBLY 2

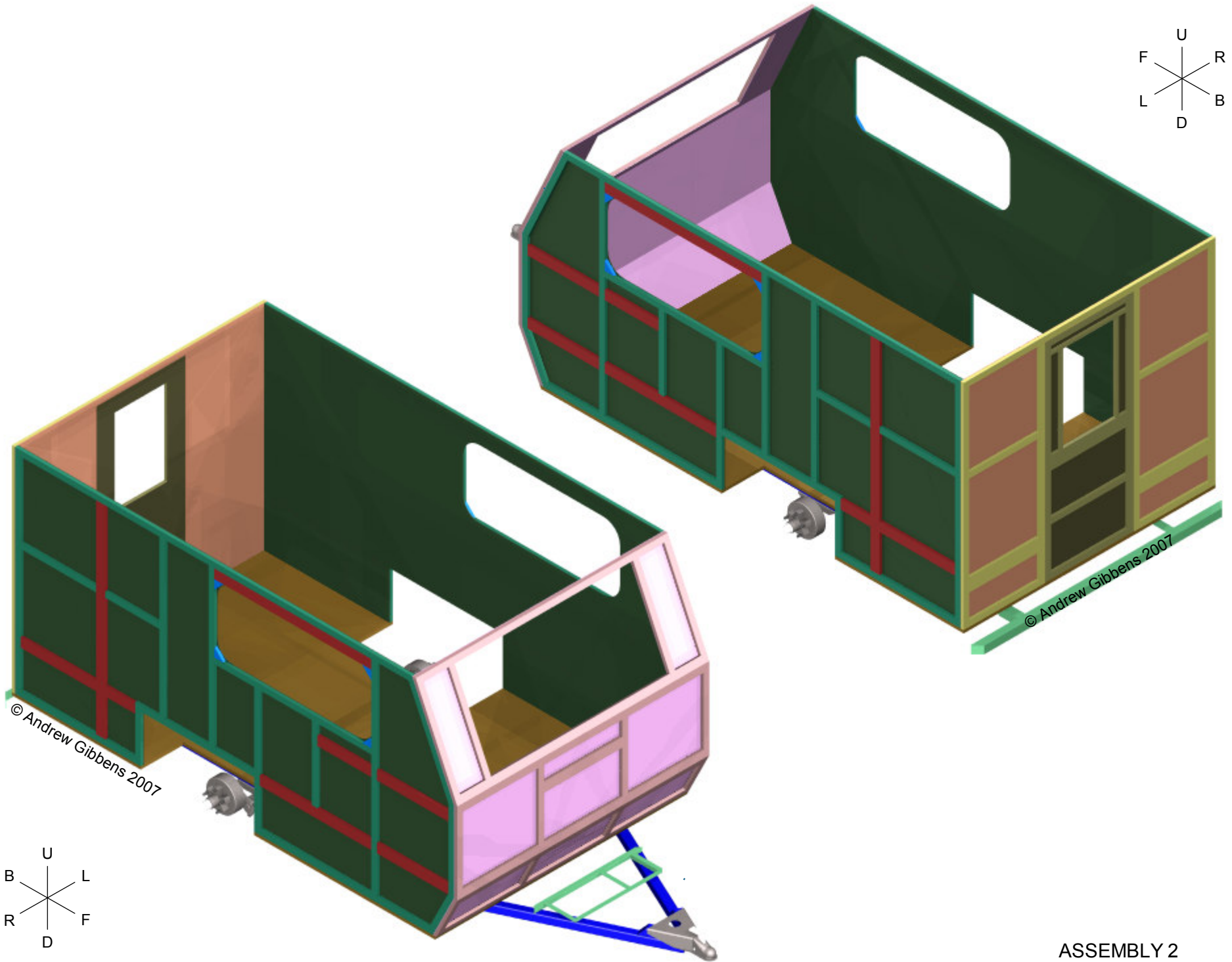
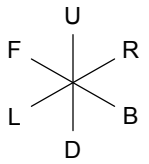
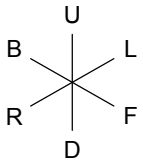
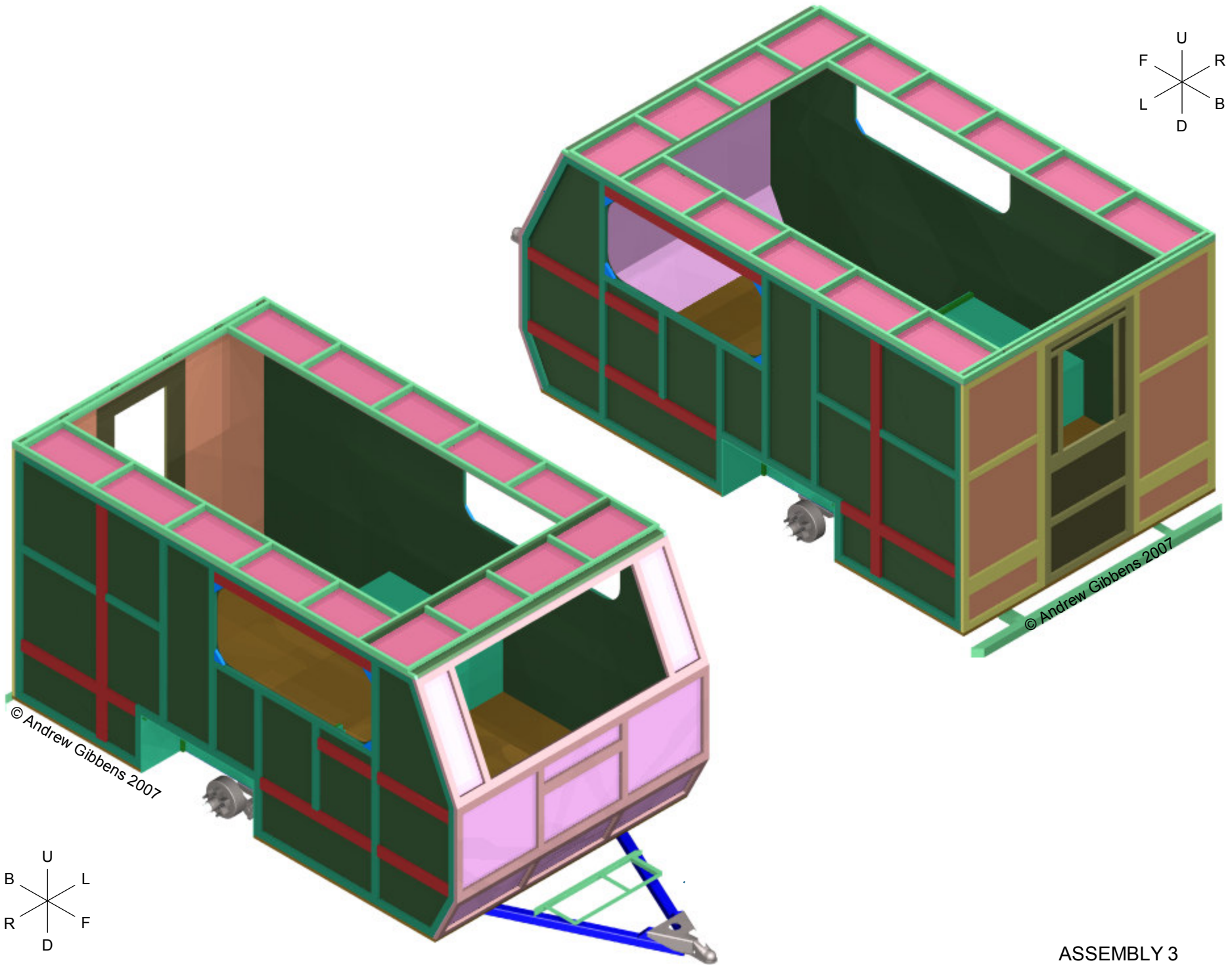
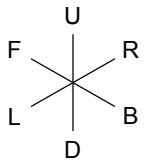

ASSEMBLY 3

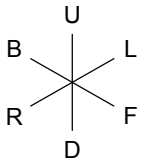
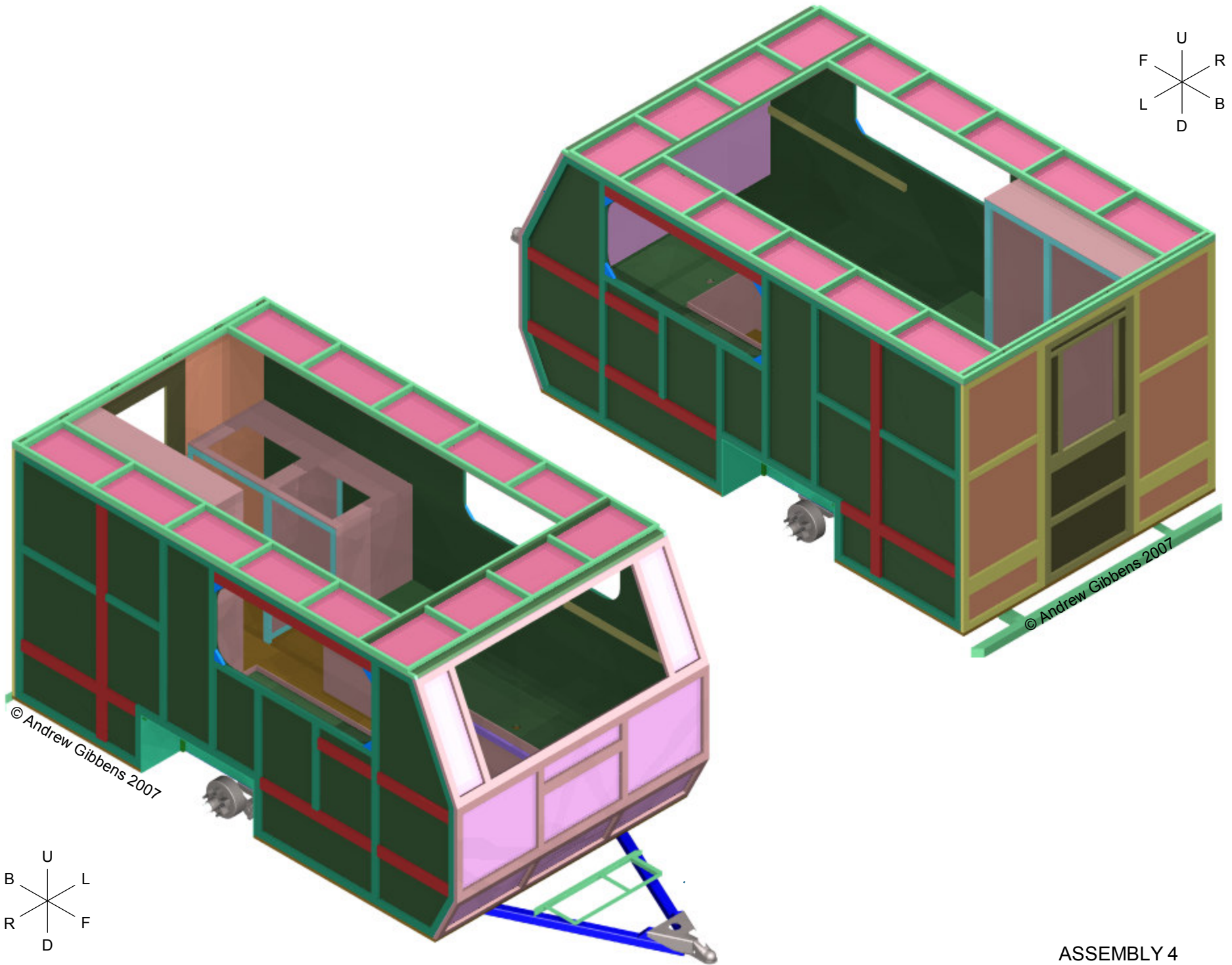
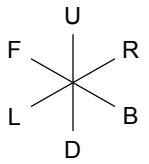

ASSEMBLY 4

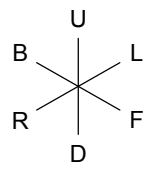
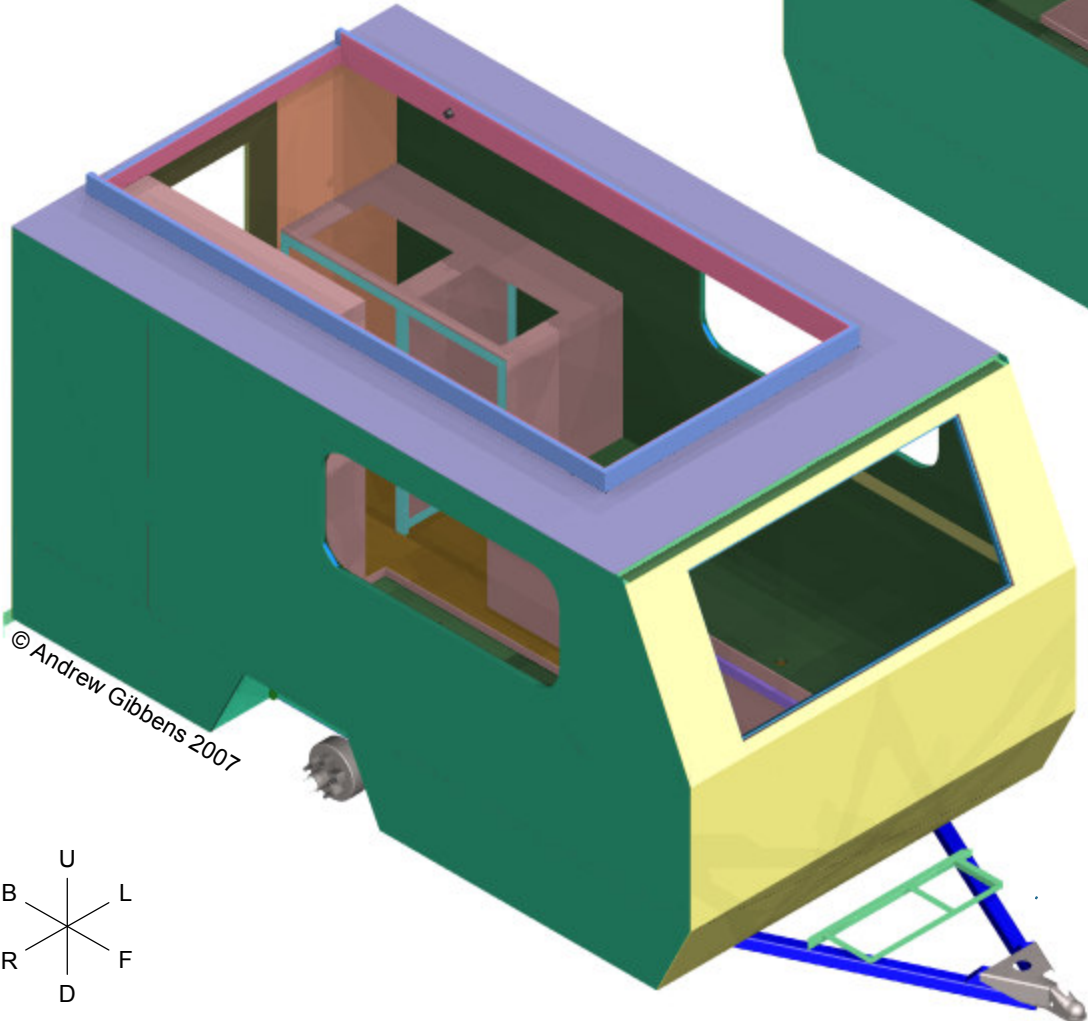
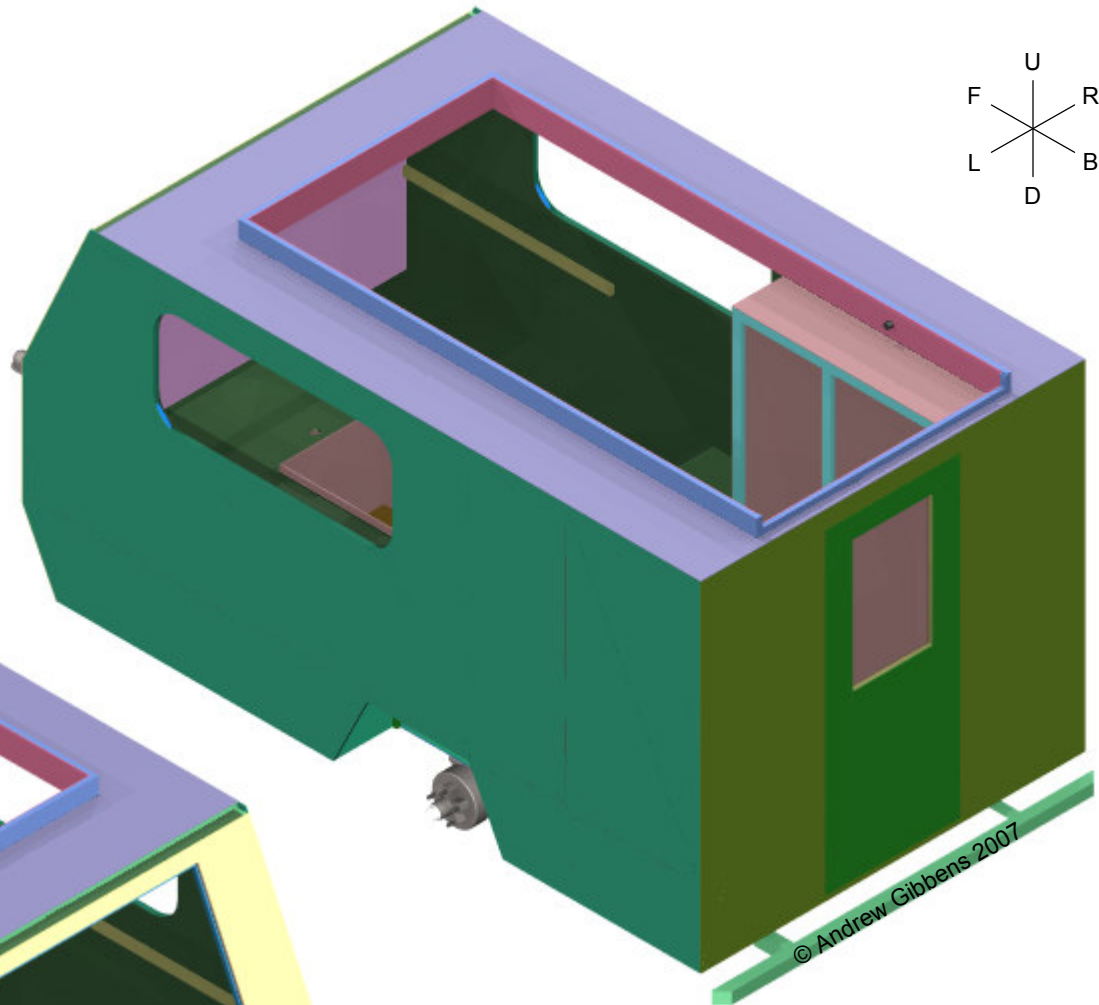
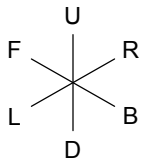

ASSEMBLY 5

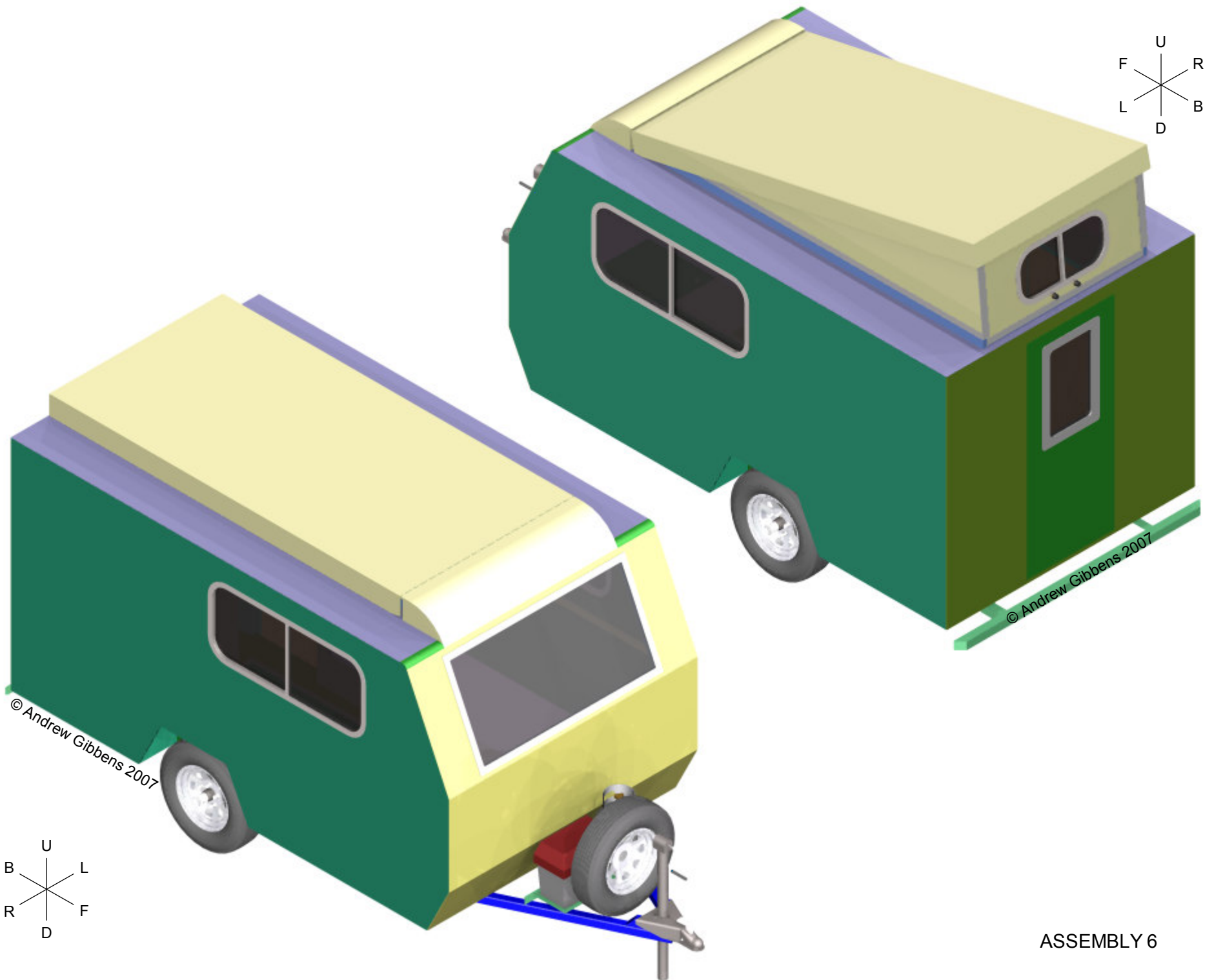

ASSEMBLY 6

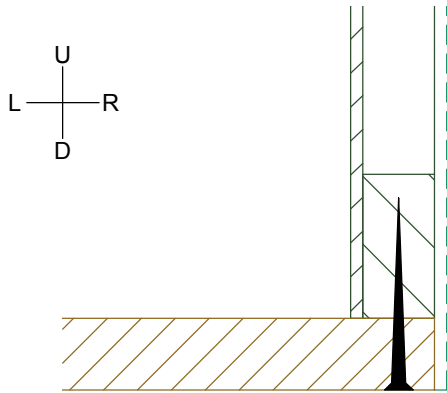

Side to Floor

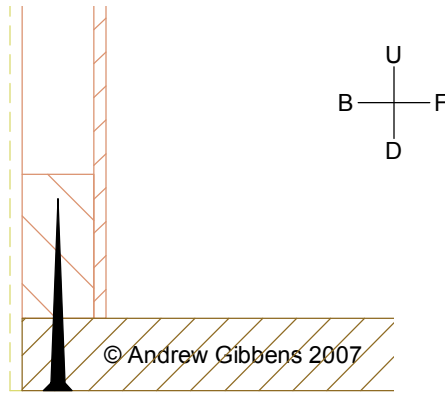

Rear to Floor

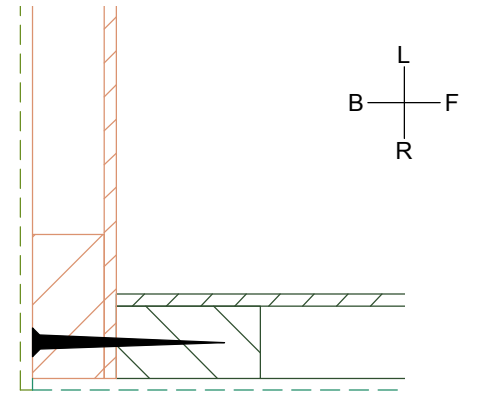

Rear to Side

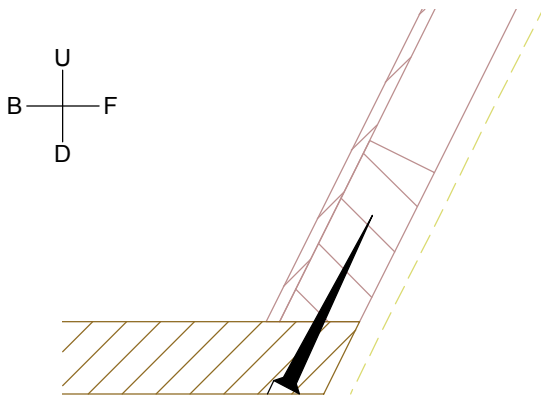

Lower Front to Floor

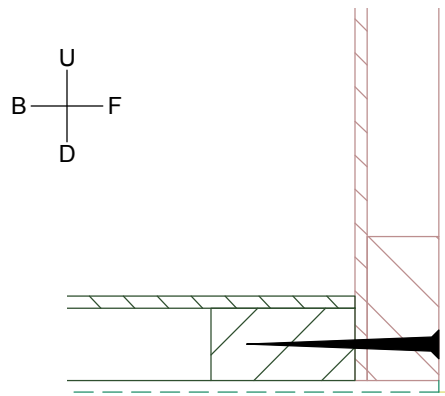

All Fronts to Side

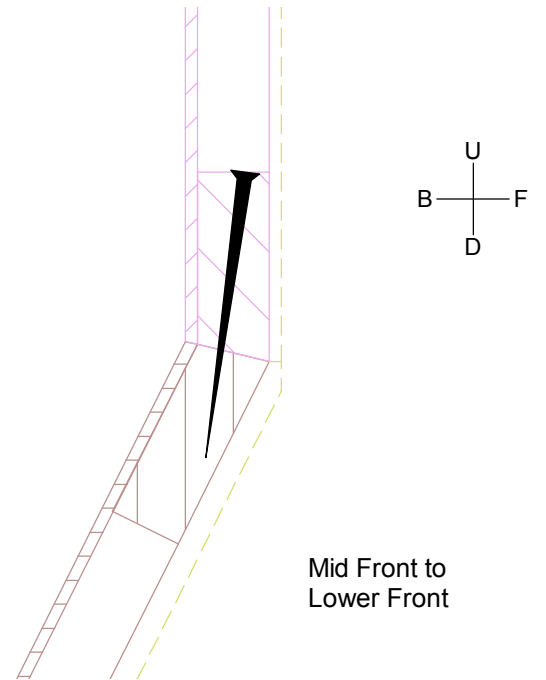

Mid Front to Lower Front

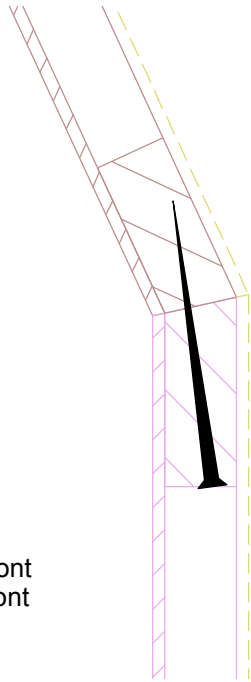
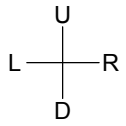

Upper Front
to Mid Front

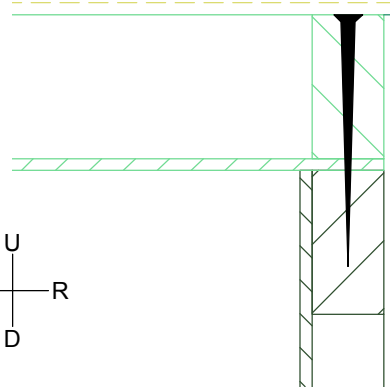
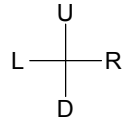

Roof to Side

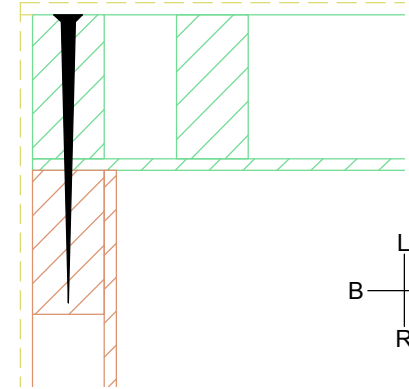
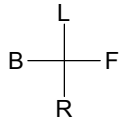

Roof to Rear

© Andrew Gibbens 2007

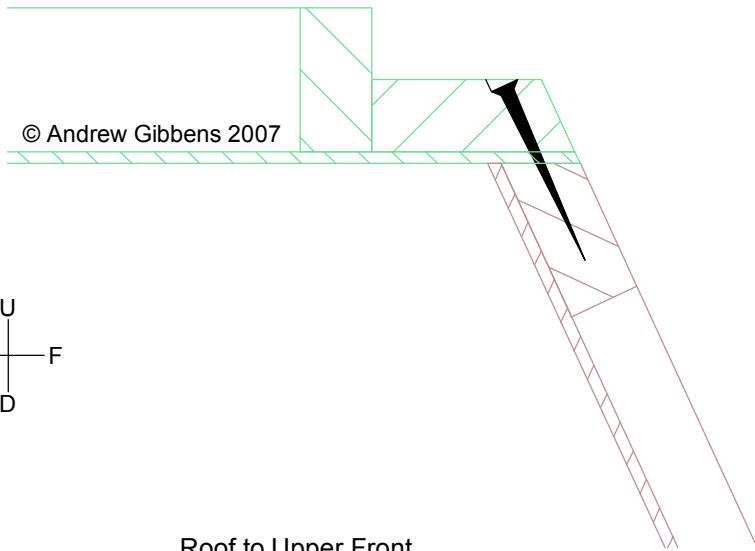
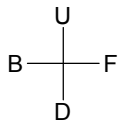

Roof to Upper Front

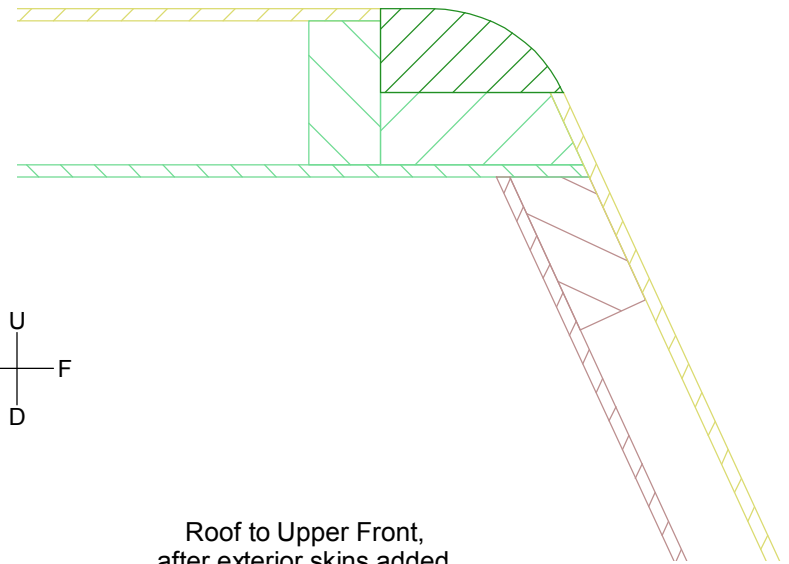
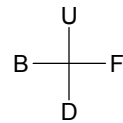

Roof to Upper Front,
after exterior skins added
either side of roof fairing

ASSEMBLY JOINTS 2
1:2

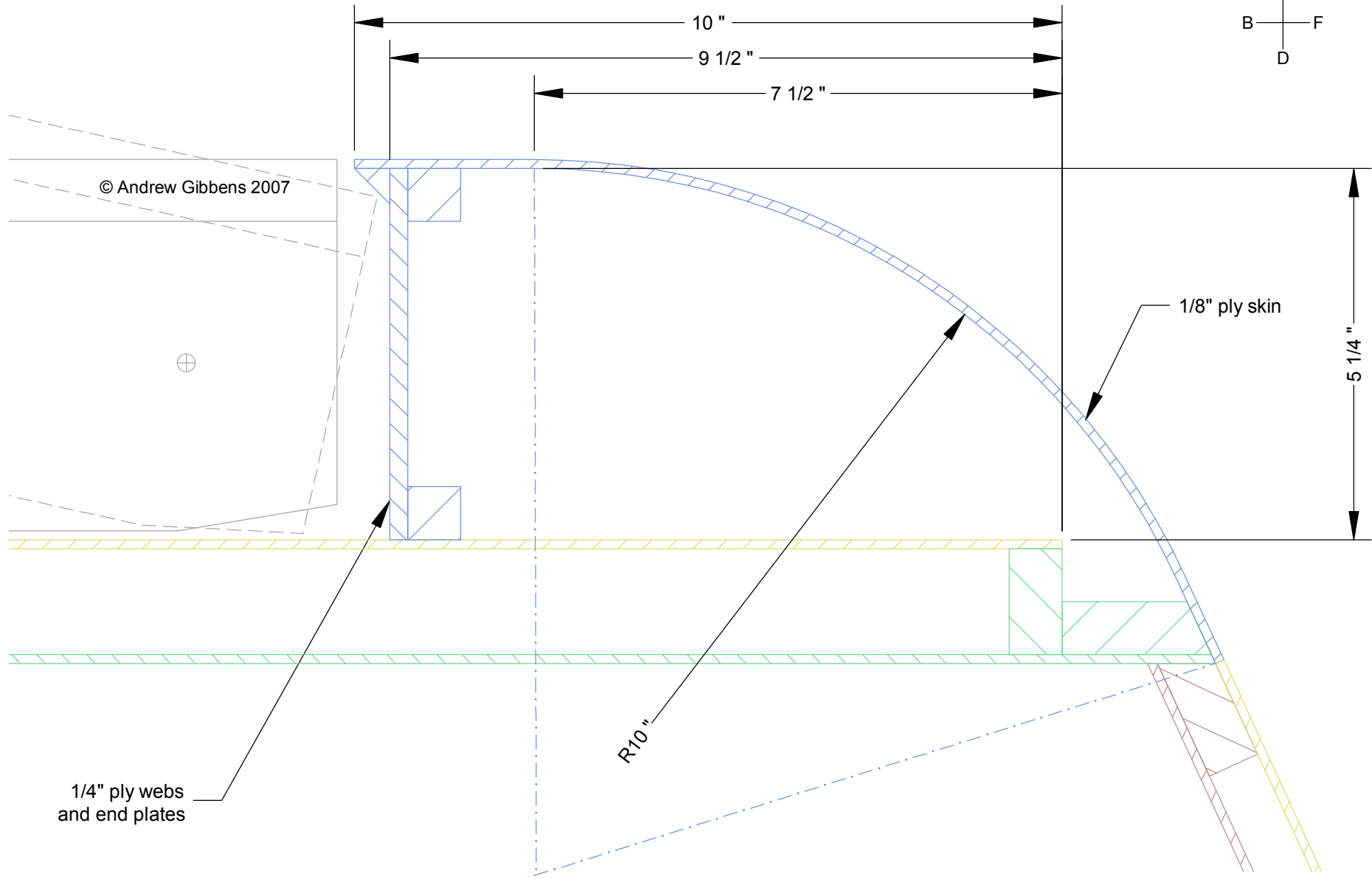
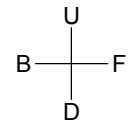

1/4" ply webs and end plates

R10"

1/8" ply skin

5 1/4"

© Andrew Gibbens 2007

Roof Fairing

ASSEMBLY JOINTS 3
1:2