

NOAA Technical Memorandum NMFS-NE-XXX

# An Interdisciplinary Review of Atlantic Cod (*Gadus morhua*) Stock Structure in the Western North Atlantic Ocean

Richard S McBride<sup>1</sup> and R Kent Smedbol<sup>2</sup> (Editors)

<sup>1</sup>National Marine Fisheries Service, 166 Water Street, Woods Hole, MA 02543

<sup>2</sup> Fisheries and Oceans Canada, Government of Canada

US DEPARTMENT OF COMMERCE  
National Oceanic and Atmospheric Administration  
National Marine Fisheries Service  
Northeast Fisheries Science Center  
Woods Hole, Massachusetts  
Month Year

# TABLE OF CONTENTS

|   |                                     |
|---|-------------------------------------|
| EXECUTIVE SUMMARY                                       | 2                                   |
| <b>1. INTRODUCTION</b>                                  | 4                                   |
| A brief history   | 4                                   |
| The ACSSWG  | 7                                   |
| Outline of this report                                  | 8                                   |
| References Cited  | 8                                   |
| <b>2. FISHERY MANAGEMENT (US/TRANSBOUNDARY) CONTEXT</b> | <b>Error! Bookmark not defined.</b> |
| <b>3. EARLY LIFE HISTORY – SPAWNING TO SETTLEMENT</b>   | <b>Error! Bookmark not defined.</b> |
| <b>4. GENETIC MARKERS</b>                               | <b>Error! Bookmark not defined.</b> |
| <b>5. LIFE HISTORY</b>                                  | <b>Error! Bookmark not defined.</b> |
| <b>6. NATURAL MARKERS</b>                               | <b>Error! Bookmark not defined.</b> |
| <b>7. APPLIED MARKERS</b>                               | <b>Error! Bookmark not defined.</b> |
| <b>8. FISHERMEN'S ECOLOGICAL KNOWLEDGE</b>              | <b>Error! Bookmark not defined.</b> |
| <b>9. SYNTHESIS</b>                                     | <b>Error! Bookmark not defined.</b> |
| <b>ACKNOWLEDGMENTS</b>                                  | 12                                  |
| <b>APPENDIX A</b>                                       | 13                                  |
| <b>APPENDIX B</b>                                       | 13                                  |
| <b>APPENDIX C</b>                                       | <b>Error! Bookmark not defined.</b> |
| <b>APPENDIX D</b>                                       | 13                                  |

## EXECUTIVE SUMMARY

An Atlantic Cod Stock Structure Working Group (ACSSWG) was formed in early 2018 to inventory and summarize all relevant peer-review information about stock structure of Atlantic cod in NAFO Divisions 5 and 6 and interactions with 4X. In addition, new data or information was also internally reviewed by the ACSSWG and included as appropriate. Additional feedback was gained from three engagement sessions, two sponsored by New England Fishery Management Council and New Hampshire Sea Grant and one sponsored by the Maine Fishermen's Forum, each of which added local ecological knowledge into the ACSSWG deliberations.

The ACSSWG followed an interdisciplinary, peer-review approach, forming topical subgroups on fishery management, early life history, genetic markers, life history, natural markers, applied markers and fishermen's ecological knowledge. All this was synthesized to evaluate the scientific support for alternative biological stock structures scenarios of cod. The material in this Technical Memorandum received internal review, by other working group members, and external review, especially under the auspices of the New England Fishery Management Council.

Since 1972, cod have been managed in US waters as two units: the Gulf of Maine and the Georges Bank management units. In their synthesis, the ACSSWG identified a number of mismatches between the current management units and biological stock structure, such as: 1) numerous instances of both phenotypic and genetic heterogeneity indicating that cod are not well mixed within each management unit, 2) adult cod in some areas exhibiting extensive movements, including swimming between current US-US and US-Canada management units, and 3) dispersal of cod larvae around Cape Cod from the western part of the Gulf of Maine Management Unit to the western part of the Georges Bank Management Unit. Finally, there is evidence of mix-stock fisheries arising from interdisciplinary evidence of sympatric winter- and spring-spawning cod in the southwestern Gulf of Maine and around Cape Cod.

In response, the ACSSWG proposes a biological stock structure that includes both an inshore-offshore separation, as well as multiple inshore stocks, including a mixed-stock composition of spring and winter spawners in multiple statistical areas. Specifically, the proposal is for five biological stocks: 1) a Georges Bank stock (fishing statistical areas 522, 525, 551, 552, 561, and 562), 2) a southern New England stock (areas 537-9), 3) a western Gulf of Maine and Cape Cod winter spawner stock (areas 513-5, 521, and 526), 4) a western Gulf of Maine spring spawner stock (overlap spatially with stock #3 in areas 513-5), and 5) an eastern Gulf of Maine stock (areas 511-2).

The ACSSWG believes that improved recognition of population structure may help prevent further loss of spawning components; better guide adjustments of allowable catch to balance fishing mortality across populations; facilitate recovery of currently depleted stocks; and strengthen the resiliency of the populations that exist within fishing areas.

# 1. INTRODUCTION

Richard S. McBride and R. Kent Smedbol

This document reviews the available data and information pertaining to stock identity of Atlantic cod (*Gadus morhua*) in the Gulf of Maine and Georges Bank regions (NAFO Divisions 5 and 6 and interactions with 4X, Fig. 1.1) and evaluates plausible alternative models of its stock structure for use in regional stock assessments. Defining the number of stocks of an exploited species, including stock boundaries and other components of its spatial complexity, is fundamental for efficient monitoring, predictive assessment, and successful management (Cadrin et al. 2005, 2014). For example, estimates of abundance and vital rates assume samples come from a unit stock: a well-mixed, reproductively isolated population without significant immigration or emigration. Cod exhibits relatively high population richness for a marine fish (Smedbol and Stephenson 2001), making this a challenging species to determine its stock structure across its extensive range in the North Atlantic Ocean.

Cod in US waters are overfished and subject to overfishing (NEFSC 2019), and among plausible mechanisms impeding its recovery are concerns that cod's biological population structure is not properly aligned with the current assessment and management units (Annala 2012; Zemeckis et al. 2014). Since 1972, cod have been managed in US waters as two units: the Gulf of Maine and the Georges Bank management units (Serchuk and Wigley 1992; NESFC 2013; Fig. 1). This management paradigm is also part of an international boundary decision, identifying separate cod stocks in the **Gulf of Maine, on Georges Bank, on Browns Bank and on the Scotian Shelf** (US 1984). In 1998, the United States and Canada established the Transboundary Resources Assessment Committee, which led to shared assessment and allocation of cod on the eastern portion of Georges Bank since 2004, under the auspices of the Transboundary Management Guidance Committee (TMGC) (Wang et al. 2009).

In 2018, the Atlantic Cod Stock Structure Working Group (ACSSWG) was formed to produce this interdisciplinary review of cod stock structure in US and adjacent Canadian waters. In this introductory material, a brief history of the spatial framework for monitoring, assessment, and management is outlined, along with short descriptions of the ACSSWG and the organization of this document.

## A brief history

Arising from the need to collect fishery catch data for research and management, a framework for delineating and naming fishing areas of the North Atlantic Ocean became established over 100 years ago (Rounsefell 1948; Halliday and Pinhorn 1990). By the 1930s, this framework had evolved from descriptive names of fishing grounds recognized by the fishery (Rich 1929; Alexander et al. 2009) to statistical areas nested into larger statistical divisions (e.g., NAFO divisions 4X, 5, 6; see **Cournane** et al. [this volume] for maps of the divisions and statistical areas). At that time, there was little biological information for the many species that were landed, but these delineations were “designed to correspond as far as possible with natural divisions of



the fish populations or with barriers to fish migrations” (Found 1933). This history set the initial framework for management units in existence today.

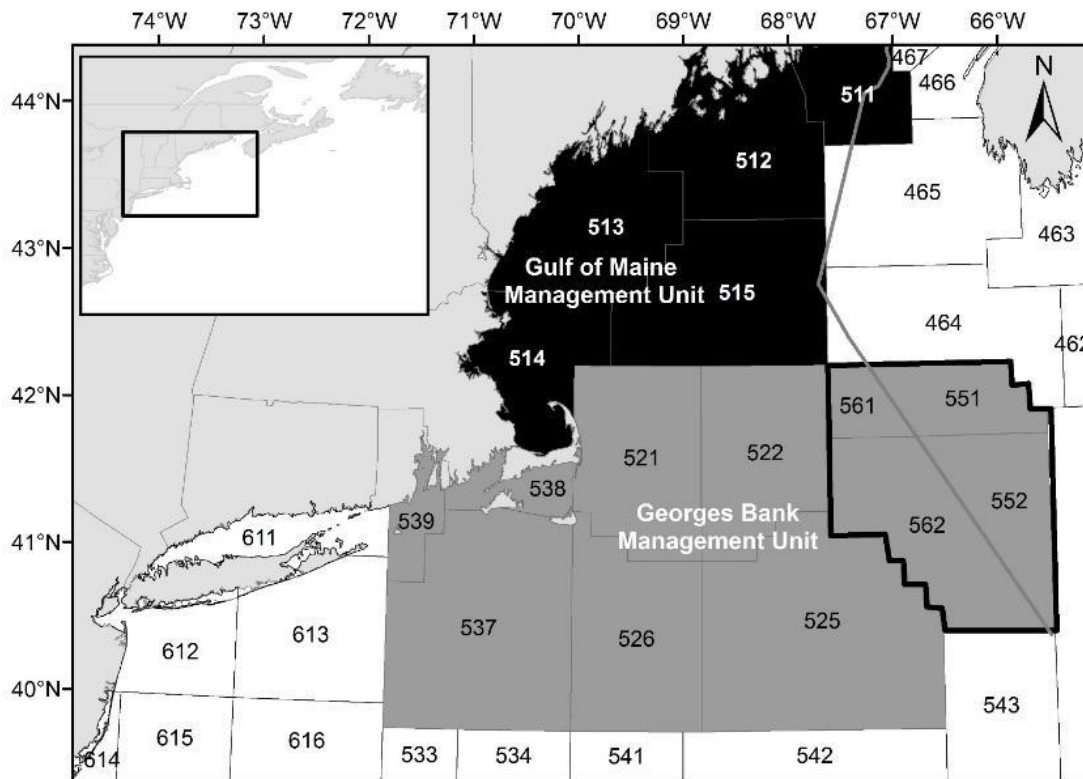


Figure 1.1. Current boundaries for the two US Atlantic cod management units – Gulf of Maine (black polygons) and Georges Bank (gray polygons) – both within the Northwest Atlantic Fisheries Organization (NAFO) Division 5. The individual polygons are ‘statistical areas,’ used to aggregate fishery catch data. Statistical areas designated in the 500s and 600s (NAFO Division 6) are in US waters, and those in the 400s (NAFO Division 4X) are in Canadian waters. Note, however: 1) cod catches attributed to NAFO Division 6 are assigned to the Georges Bank US management unit; 2) areas 551-2 are in Canadian waters, and together with US areas 561-2, these four areas (outlined in black) are assessed and managed jointly between the United States and Canada under the auspices of the Transboundary Resources Assessment Committee (TRAC); and 3) the gray line running from area 511 and south through the TRAC area is the Hague line, the US-Canadian maritime border. Catches on the US side of the Hague line in areas 464, 465, and 511 are assigned to the Gulf of Maine unit, whereas catches on the Canadian side of the Hague line in these areas are assigned to Canada.

As more information accumulated, it became evident that this existing statistical grid system was better suited for some species than others (e.g., Grosslein 1973). Further alignment of the spatial structure of fish populations with this statistical reporting structure was an explicit goal of the regional governing bodies that followed: first with the North American Council on Fishery Investigations (1930s-1950s), then the International Commission for the Northwest Atlantic Fisheries (1950s-1970s), and finally, since 1970, the Northwest Atlantic Fisheries Organization

(NAFO) (Halliday and Pinhorn 1990). Nonetheless, administrative and co-management realities have kept this grid system in place, primarily because changing the boundaries would disrupt the historical allocation of catch to areas. Therefore, the aggregation, evaluation, and synthesis of data and information in this document relates to this framework of statistical areas nested in NAFO Divisions (see Synthesis, Chapter 9).

Sufficient information about cod existed by the 1960s for an interdisciplinary review on biological population structure by Templeman (1962), based on meristics (vertebral numbers), parasites, distributional and migratory patterns, growth, year-class strength, and spawning times and locations. This and subsequent information supported the broad patterns of biological stock structure that roughly corresponded to the fishing divisions in both latitudinal and inshore-offshore patterns. For example, following Jordan's rule, vertebral counts increased with increasing latitude across the entire range of the species (Jordan 1891; McDowall 2008), and the average count from **Nantucket Shoals, the southernmost sample**, was lower than averages from any other region (Templeman 1981). Parasite infestation rates suggested two groups of cod in the Gulf of Maine separate from a Georges Bank and a southern New England population (Sherman and Wise 1961). Wise (1963) summarized decades of tagging cod in New England's waters to define 4 geographic groups: cod of the Gulf of Maine, cod of the offshore banks (e.g., Georges & Brown Banks), cod of **southern New England** and the **Great South Channel**, and New Jersey coastal cod (see **Cournane** et al. [this volume] for maps of locations mentioned in the text). This information also supported notable connectivity among statistical divisions. For example, tag returns showed intermingling of adults across NAFO divisions 5Z and 4X, such as between the offshore **Browns Bank and eastern Georges Bank**, as well as seasonal migration between Nantucket Shoals **and New Jersey and as far southwest as North Carolina** (NAFO division 6) (McKenzie 1956, Wise and Jensen 1960, Wise 1963).

In the 1960s a standardized, fishery-independent groundfish survey began to collect life history samples that provided additional information types for stock identification of cod. For example, the near absence of juvenile cod in survey tows from Block Island to Cape Hatteras suggested that the cod from that area were not self-sustaining (Serchuk and Wood 1979). Also, significant differences in the mean lengths-at-age of young cod were noted in 3 areas: the Gulf of Maine, on Georges Bank, and off Cape Cod/southern New England. Differences in age at maturity were noted among Gulf of Maine, Georges Bank, and Browns Bank (Penttila and Giffords 1976; Livingston and Dery 1976; Serchuk and Wood 1979). Other information arising in the 1970s included differences in body color, otolith shape and size, and serological or biochemical methods to infer genetic differences (Templeman 1978). In the decades since, this interdisciplinary field of stock identification has expanded further, using both traditional and newer technologies to identify population richness and their boundaries, or discriminate populations in mixed stocks of catch, including cod (Lough 2004; Cadrin et al. 2005, 2014; Annala 2012; Zemeckis et al. 2014; Dean et al. 2019).

Declining populations of cod have occurred despite substantially reduced fishery catch and a series of management actions over decades. This has led to concerns that existing cod management units have not adequately captured cod's biological stock structure, contributing to delays in rebuilding (Smedbol and Stephenson 2001; Annala 2012; Zemeckis et al. 2014). Fishery management systems ideally address a single, panmictic population within a

management unit, but in this case, historic evidence demonstrates both uneven declines in abundance among aggregations of cod within a management unit, and even complete extirpation of spawning groups within management units (Ames 2004; Smedbol and Stephenson 2001), suggesting heterogeneous levels of productivity or stability within management units that may be tied to cryptic stock structure. Moreover, recent investigations have demonstrated sympatric but genetically distinct populations within the southwestern Gulf of Maine: winter- and spring-spawning subpopulations (Kovach et al. 2010; Siceloff and Howell 2013; Dean et al. 2014; Zemeckis et al. 2019) indicating a mixed stock fishery operates in this management unit (Dean et al. 2019). Finally, compilations of fisherman's ecological knowledge have identified fine-scale structure of spawning grounds around Cape Cod, including the Great South Channel and Nantucket Shoals, and on Georges Bank (DeCelles et al. 2017), as well as historically within the eastern and western Gulf of Maine (Ames 1997, 2004).

## The ACSSWG

Although the data available for cod is more detailed than available for most species, persistent scientific uncertainty related to cod stock structure has been identified as a key factor contributing to difficulties in rebuilding of cod in US waters (Annala 2012). In response, an Atlantic Cod Stock Structure Working Group ([ACSSWG](#); Appendix A) was formed in early 2018 to inventory and summarize all relevant peer-review information about stock structure of Atlantic cod in NAFO Divisions 5 and 6 and interactions with 4X. In addition, new data or information was also internally reviewed by the ACSSWG and included as appropriate. Additional feedback was gained from two engagement sessions with industry and other interested parties to add local ecological knowledge into the ACSSWG deliberations ([New Hampshire Sea Grant](#)). All this was synthesized to evaluate the scientific support for alternative biological stock structure scenarios of cod. The ACSSWG believes that improved recognition of population structure may help prevent further loss of spawning components; better guide adjustments of allowable catch to balance fishing mortality across populations; facilitate recovery of currently declined stocks; and strengthen the resiliency of the populations that exist within fishing areas.

This Technical Memorandum assembles the findings of the ACSSWG with respect to these three terms of reference (TORs, Appendix B):

1. Inventory and summarize all relevant peer-review information about stock structure of Atlantic cod in NAFO Divs. 5 and 6 and interactions with 4X. Evaluate the relative importance of the information with respect to developing a holistic understanding of Atlantic cod stock structure.
2. Identify and evaluate any new or existing data or information about the stock structure of Atlantic cod in NAFO Divs. 5 and 6 and interactions with 4X, and subject to a peer-review by the working group. Integrate any additional information into the inventory developed in TOR 1.

3. Using a holistic approach, synthesize all available information (TOR 1 and 2) and develop sets of possible biological stock structures and consider scientific support for each alternative. In developing alternative stock structures, consider the temporal stability of stock structure and how the available information can inform the knowledge of stock structure over time.

The ACSSWG formed topical subgroups on fishery management, early life history, genetic markers, life history, natural markers, applied markers and fishermen's ecological knowledge (Chapters 2-8, this volume). Each subgroup reviewed all published literature on the topic as well as new information to provide conclusions on stock identity from each discipline's perspective. Chapter drafts were reviewed by a working group member who was not in the subgroup as well as an external reviewer. This interdisciplinary synthesis by the ACSSWG led to a consensus proposal of biological stock structure (Chapter 9, this volume). This Technical Memorandum received external peer-review under the auspices of the New England Fishery Management Council.

## Outline of this report

Following this introductory material is a section providing a fishery management context, which includes reference maps, locations named in the text, and an outline of management by the United States and transboundary agreements with Canada. Chapters that cover the individual disciplines reviewed by the ACSSWG follow:

- Early life history
- Genetic markers,
- Life history,
- Natural markers,
- Applied markers,
- Fishermen's ecological knowledge.

A synthesis chapter develops a set of plausible biological stock structures and evaluates the scientific evidence for each to determine the most accurate representation of Atlantic Cod stock structure. As the ultimate purpose of this determination is for use in regional stock assessment and management, thresholds for scientific support are that the proposed biological stock structure should be temporally stable and accurately capture the available data and assessment model frameworks.

The report ends with a complete list of the working group members (Appendix A), TORs (Appendix B), objectives (Appendix C), and a glossary of terms (Appendix D).

## References Cited

Alexander KE, Leavenworth WB, Cournane J, Cooper AB, Claesson S, Brennan S, Smith G,

Rains L, Magness K, Dunn R et al. 2009. Gulf of Maine cod in 1861: historical analysis of fishery logbooks, with ecosystem implications. *Fish Fish.* 10(4):428-449.

Ames EP. 2004. Atlantic cod stock structure in the Gulf of Maine. *Fisheries.* 29(1):10-28.

Annala JH. 2012. Report of the workshop on stock structure of Atlantic cod in the Gulf of Maine regions, June 12-14, 2012, Portsmouth, NH. Available from: <http://www.gmri.org/resources/resource-archive/cod-stock-structure-workshop-report>.

Cadrin SX, Friedland KD, Waldman JR. 2005. *Stock Identification Methods*. Burlington: Academic Press.

Cadrin SX, Kerr LA, Mariani S. 2014. *Stock Identification Methods*. Second Edition. San Diego: Academic Press.

Dean MJ, Hoffman WS, Zemeckis DR, Armstrong MP. 2014. Fine-scale diel and gender-based patterns in behaviour of Atlantic cod (*Gadus morhua*) on a spawning ground in the Western Gulf of Maine. *ICES J Mar Sci.* 71(6):1474-1489.

Dean M, Elzey S, Hoffman W, Buchan N, Grabowski JH. 2019. The relative importance of sub-populations to the Gulf of Maine stock of Atlantic cod. *ICES J Mar Sci.* doi: 10.1093/icesjms/fsz083.

DeCelles GR, Martins D, Zemeckis DR, Cadrin SX. 2017. Using Fishermen's Ecological Knowledge to map Atlantic cod spawning grounds on Georges Bank. *ICES J Mar Sci.* 74(6):1587-1601.

Found WA. 1933. North American council on fishery investigations. Third Annual Report of the Department of Fisheries for the year 1932-33. Ottawa:p. 25-27. Not seen, cited from Halliday and Pinhorn (1990; page 4).

Grosslein MD. 1973. Mixture of species in subareas 5 and 6. International Commission for the Northwest Atlantic Fisheries, Research Document. Serial No. 2911, 73/9:1-49.

Halliday RG, Pinhorn AT. 1990. The delimitation of fishing areas in the northwest Atlantic. *Journal of Northwest Atlantic Fishery Science.* 10:1-51.

Jordan DS. 1891. Relations of temperature to vertebrae among fishes. *Proc U S Natl Mus.* 14:107-120.

Kovach AI, Breton TS, Berlinsky DL, Maceda L, Wirgin I. 2010. Fine-scale spatial and temporal genetic structure of Atlantic cod off the Atlantic coast of the USA. *Mar Ecol Prog Ser.* 410:177-195.

Lough RG. 2004. Essential Fish Habitat Source Document: Atlantic cod, *Gadus morhua*, life history and habitat characteristics (2nd Edition). NOAA Tech Memo. NMFS-NE-190:94 pp.

- McDowall RM. 2008. Jordan's and other ecogeographical rules, and the vertebral number in fishes. *Journal of Biogeography*. 35:501–508.
- McKenzie RA. 1956. Atlantic cod tagging off the southern Canadian mainland. *Bull Fish Res Bd Can*. 105:1-93.
- NEFSC, (Northeast Fisheries Science Center). 2019. Operational Assessment of 14 Northeast Groundfish Stocks, Updated through 2018. US Department of Commerce, Northeast Fisheries Science Center Reference Document 19-DRAFT. Available from: <https://www.nefsc.noaa.gov/nefsc/saw/2019-groundfish-docs/Prepublication-NE-Grndfish-10-3-2019.pdf>
- Rich WH. 1929. Fishing grounds of the Gulf of Maine. *Rept US Comm Fish*. 1929:51-117.
- Rounsefell GA. 1948. Development of fishery statistics in the North Atlantic. *US Fish and Wildlife Service. Special Scientific Report* 47:27 p.
- Serchuk FM, Wigley SE. 1992. Assessment and management of the Georges Bank cod fishery: an historical review and evaluation. *J Northw Atl Fish Sci*. 13:25-52.
- Serchuk FM, Wood PW. 1979. Review and status of the southern New England/Middle Atlantic cod, *Gadus morhua*, populations. Woods Hole (MA): NMFS-NEFSC, Woods Hole Laboratory Reference Document. 79-37:77 pp. Available from: <https://www.nefsc.noaa.gov/publications/series/whlrd/whlrd7937.pdf>.
- Sherman K, Wise JP. 1961. Incidence of the cod parasite *Lernaecera branchialis* L. in the New England area, and its possible use as an indicator of cod populations. *Limnol Oceanog*. 6(1):61-67.
- Siceloff L, Howell WH. 2013. Fine-scale temporal and spatial distributions of Atlantic cod (*Gadus morhua*) on a western Gulf of Maine spawning ground [Article]. *Fish Res*. 141:31-43.
- Smedbol RK, Stephenson R. 2001. The importance of managing within-species diversity in cod and herring fisheries of the north-western Atlantic. *J Fish Biol*. 59:109-128.
- Templeman W. 1962. Divisions in cod stocks of the northwest Atlantic. *International Commission for the Northwest Atlantic Fisheries Redbook. Serial No 989(Document No. 47)*:1-36.
- Templeman W. 1978. Stock discrimination in marine fishes. *NAFO Sci Coun Studies*. 6:57-62.
- US US. 1984. Case concerning delimitation of the maritime boundary in the Gulf of Maine area. Volume IV Counter-Memorial of the United States of America. *International Court of Justice Pleadings, Oral Arguments, Documents*.

Wang Y, L O'Brien, Gavaris S. 2009. 2009 Benchmark Assessment Review for Eastern Georges Bank Cod. TRAC Ref Doc 2009/07.108.

Wise J, Jensen A. 1960. Stocks of the important commercial species of fish in the ICNAF Convention area. Int Comm NW Atl Fish Ann Meet Doc 25, ser No 743:1-14.

Wise JP. 1963. Cod groups in the New England area. Fish Bull. 63(1):189-203.

Zemeckis DR, Dean MJ, DeAngelis AI, Van Parijs SM, Hoffman WS, Baumgartner MF, Hatch LT, Cadrin SX, McGuire CH. 2019. Identifying the distribution of Atlantic cod spawning using multiple fixed and glider-mounted acoustic technologies. ICES J Mar Sci. doi: 10.1093/icesjms/fsz064.

Zemeckis DR, Martins D, Kerr LA, Cadrin SX. 2014. Stock identification of Atlantic cod (*Gadus morhua*) in US waters: an interdisciplinary approach. ICES J Mar Sci. 71(6):1490-1506.

These headers are just to update the table of contents  
Each chapter is a separate file,  
except the Acknowledgements and Appendices are at the end of Chapter 9

## **2. FISHERY MANAGEMENT (US/TRANSBOUNDARY) CONTEXT**

## **3. EARLY LIFE HISTORY – SPAWNING TO SETTLEMENT**

## **4. GENETIC MARKERS**

## **5. LIFE HISTORY**

## **6. NATURAL MARKERS**

## **7. APPLIED MARKERS**

## **8. FISHERMEN'S ECOLOGICAL KNOWLEDGE**

## **9. SYNTHESIS**

## **ACKNOWLEDGMENTS**



**APPENDIX A**

**APPENDIX B**

**APPENDIX C**

**APPENDIX D**

## 2. EARLY LIFE HISTORY: SPAWNING to SETTLEMENT

Micah Dean, Greg DeCelles, Doug Zemeckis, and Ted Ames

### Abstract

The period between spawning and juvenile settlement is a critical part of the life history of Atlantic cod. Dispersal of pelagic early life stages from spawning grounds to nursery areas creates connectivity links between regions that can shape the structure of a population. In this chapter, we review larval transport studies for cod within U.S. waters, as well as examine bottom trawl and ichthyoplankton survey datasets for evidence of transport pathways. All available data were summarized and integrated to form conclusions on the connectivity between four regions known to host persistent spawning grounds: Gulf of Maine (GOM); Georges Bank (GBK); Cape Cod (CC); and Southern New England (SNE). Both GOM and GBK appear to be zones of significant self-recruitment with little input from outside, supporting the continued use of at least two separate management units. Several lines of evidence suggest major connectivity pathways exist between GOM↔CC, CC↔SNE, and SNE↔SNE; with minor pathways between GOM↔SNE and GBK↔SNE. From an early life history perspective, the GOM, CC, and SNE regions appear to function as single group, which is distinct from the GBK region.

### Introduction

Early life history stages can help elucidate the population structure of a fish stock, particularly when considered in the context of a holistic approach that includes multiple lines of supporting evidence (Hare and Richardson, 2014). Discrete spawning events and transport pathways lead to discontinuous egg and larval distributions that are commonly identified in association with genotypic and phenotypic differences (Hare, 2005) and can have an important influence on the population structure of marine fishes (e.g., Espeland et al. 2007). Early life history stages have been used within a multidisciplinary framework to investigate the stock structure of several species including American lobster, Japanese eels, Atlantic herring, and Atlantic bluefin tuna (see reviews in Hare 2005, and Hare & Richardson 2014). The aim of this chapter is to provide a comprehensive review of the early life history of Atlantic cod in U.S. waters, in order to provide a supporting line of evidence for the underlying structure of the population.

For the purpose of this chapter, we will consider “early life history” to include all phases of life from egg release (i.e., spawning) through juvenile settlement. This portion of the Atlantic cod life cycle forms the critical link between reproductive potential and subsequent recruitment,

and therefore lays the foundation for stock dynamics (Hare & Richardson, 2014). Given a high individual fecundity (May, 1967) and a prolonged planktonic stage (Bolz and Lough, 1988), cod have the potential for broad dispersal and mixing among spawning groups. Yet, despite this reproductive strategy, most cod stocks have fine-scale population structure that persists across many generations, as evidenced by high fidelity to persistent spawning sites (Robichaud and Rose, 2001; Skjæraasen *et al.*, 2011; Dean *et al.*, 2014) and genetic structuring (e.g., Kovach *et al.* 2010; Hutchinson *et al.* 2001).

One consequence of a dispersive life history is high mortality during early life (Tian *et al.*, 2007), with a variety of biotic and abiotic factors constraining the survival of young cod (Werner *et al.*, 1996). The single-most important factor influencing the distribution of eggs and larvae is the timing and location of spawning (Hare & Richardson 2014). Post egg release, a variety of physical oceanographic forces affect the pelagic transport of offspring, which can be modified by biological characteristics (e.g., buoyancy) and larval behavior (Huret *et al.*, 2007). Spatio-temporal overlap with primary prey species determines the extent of losses due to starvation (Lough *et al.*, 2005; Friedland *et al.*, 2013). In addition, specific habitat requirements determine which surviving larvae ultimately become settled benthic juveniles (Grabowski *et al.*, 2018). Therefore, despite a high reproductive and dispersive capacity, only a small number of individuals overcome each life history hurdle and survive to recruit to the population. Understanding the sequence of these early life stages can help reveal the structure of the population and the mechanisms that maintains it.

Using hydrodynamic models, numerous particle simulation studies have been conducted for the Gulf of Maine and Georges Bank to examine the probability of transport between specific spawning grounds and known juvenile settlement habitat (Huret *et al.* 2007; Churchill *et al.* 2011, 2017; Werner *et al.* 1993, 1996). These studies provide an overall picture of the potential early-life connectivity between areas within the range of cod in US waters. However, it is important to consider that larval transport potential does not necessarily indicate survival to the juvenile stage. Fortunately, there is also a wealth of empirical information on the spatial and seasonal distribution of early life stages of cod within the region, from spawning through settlement. When considered independently, each life stage offers only a limited perspective on population structure, with many possible interpretations; however, when examined *collectively*, we can reconstruct this adult-juvenile link to inform hypotheses about regional connectivity within and between stocks.

The primary objective of this chapter is to review previously published studies, in addition to survey datasets, in order to evaluate the early-life connectivity between areas within the range of Atlantic cod in US waters. Specifically, we sought to answer the following questions: 1) is there evidence of major connectivity across the current two-stock management boundary? and 2) is there an alternative set of boundaries that better aligns with regional patterns in reproductive ecology and early life history?

## Methods & Materials

### *Study Area and Spatial Strata*

Early-life connectivity was evaluated according to a set of four spatial strata that captures the broad-scale patterns in regional spawning activity. To augment the relevance and interpretation of results, strata were aligned to the NOAA “statistical areas” used for fishery-dependent reporting (Figure 2.1): GOM (areas 511-514), CC (area 521), SNE (areas 526, 527, 538, 539), and GBK (areas 522, 525, 551, 552, 561, 562). The GOM stratum is equivalent to the current definition for the Gulf of Maine management unit, whereas the other three strata collectively make up the current definition for the Georges Bank management unit.

### *Survey Data Sources*

Cod eggs and larvae have routinely been captured throughout the region via annual ichthyoplankton cruises since 1971. The study design for these surveys has changed multiple times over the years, but under each evolution has sought to broadly sample in space and time the ichthyoplankton community across the continental shelf of the US Atlantic coast between North Carolina and Nova Scotia (Richardson *et al.*, 2010). On each survey cruise, a 61 cm Bongo net was used to sample the water column from the surface to within 5 m of the seafloor up to a maximum of 200 m. Prior to 1999, the mesh size of the net was 505  $\mu\text{m}$ , which was reduced to 333  $\mu\text{m}$  after 1999. The available data include the relative abundance of fish eggs and larvae (in units of  $\#/m^2$  and  $\#/m^3$ ), identified to lowest possible taxon, which is often to the species.

It is not possible to distinguish between the early-stage eggs of cod, haddock, and witch flounder through typical visual examination of physical attributes (Markle and Frost, 1985; Lough *et al.*, 1994). Regardless, researchers in some parts of the North Atlantic have used the relative abundance of eggs to identify the locations of cod spawning and early dispersal by making assumptions about the species mix, based on the presence and reproductive phenology of cod, haddock, and witch flounder in those regions (e.g., Ouellet *et al.* 1997). Unfortunately, it is not reasonable to make such assumptions about cod-haddock-witch eggs within the range of cod in US waters. The multitude and diversity of spawning groups mean that cod eggs could be present in nearly every month, creating substantial overlap with the spawning seasons of haddock and witch flounder, both of which are relatively abundant in the Gulf of Maine and Georges Bank management units. Berrien and Sibunka (1999) attempted to circumvent this issue by determining the species mix of *late* stage eggs, and applying those proportions to the abundance of early stage eggs. Given the inherent uncertainty in this approach and that late stage cod-haddock-witch eggs have not been identified to species since the 1990s, we have concentrated on just the larval phase for spatial analysis.

Although several bottom trawl surveys operate in the region, only two routinely catch recently settled age-0 juvenile cod in appreciable numbers. The NEFSC survey utilizes a small mesh net to make standard tows at randomly selected stations throughout the continental shelf from North Carolina to Nova Scotia. Each year, the NEFSC survey covers the entire study area in two seasonal cruises: the “Spring” cruise, which began in 1968, typically reaches the New England region in March-April and captures recently settled juveniles that were spawned during the late fall and early winter months; The “Fall” cruise (September-October; beginning 1963) captures juveniles that were spawned in spring and early summer months. Using a similar stratified-random design concept and small mesh bottom trawl, the Massachusetts Division of Marine Fisheries (MADMF) operates Spring (May) and Fall (September) cruises, that are restricted to just Massachusetts State Waters. The MADMF survey has operated every year since 1978 and encompasses juvenile settlement areas within the GOM, CC and SNE strata.

### *Spatial Models*

In order to better evaluate connectivity between spatial strata, survey observations of larval cod were summarized via geostatistical interpolation (i.e., kriging). Geostatistical approaches have been recommended for the analysis of early life history data, as they allow for more robust inferences regarding likely transport patterns and discreteness of spawning events (Hare and Richardson, 2014). The overarching goal of this process was to disentangle the general spatial pattern from interannual variability and the waxing and waning of various spawning groups. For most of the years encompassed by the ichthyoplankton sampling programs, the relative abundance of cod larvae found in the GBK stratum was far greater than the other three areas. As a result, the signal originating from Georges Bank spawning nearly overwhelms that of the Gulf of Maine or Southern New England. Because the focus of this investigation is on connectivity between areas, and is less concerned with relative abundance, only the *occurrence* of larvae was used to describe the spatial distribution of cod during their pelagic phase.

Empirical variograms were calculated by month and year (8 km lag bins, out to 200 km) and then an exponential variogram model was fit to the median values by month (Figure 2.2). Monthly variogram models were then applied to survey observations to generate a predicted surface for each year and month. Finally, these maps were then pixel-averaged across years to capture the general spatial pattern of the probability of larval occurrence.

The spatial pattern of settlement was summarized in a similar manner. For each bottom trawl survey dataset, there was a distinct length frequency mode, centered on 3-5 cm, representing the first observation of a cohort at age-0. In most cases, this group of fish could be isolated by selecting lengths shorter than 8 cm (Figure 2.3). Due to the similarities in survey timing and gear, the NEFSC and MADMF datasets were pooled together by season, and the occurrence of recently settled juveniles < 8 cm was used as the input data for spatial analysis. Empirical variograms were calculated by year and season, and an exponential variogram model was fit to the median values by season (Figure 2.4). Given an apparent finer-scale structure to the

spatial relationship of observed settlement, substantially smaller lag bins were used (0.8 km bins, out to 20 km). Seasonal variogram models were applied to survey observations to generate predicted surfaces by year/season, which were then pixel-averaged across years to create a general map of settlement probability.

### *Time series correlations*

Given the variation in spatial coverage and seasonal timing caused by the programmatic changes to the Ichthyoplankton surveys (Richardson *et al.*, 2010), we did not attempt to create regional/seasonal time series of larval abundance. Although some changes have occurred over the course of the bottom trawl surveys, the spatial and seasonal coverage have been relatively consistent. As such, we focused on time series correlations of the abundance of recently settled juveniles. For both spring and fall cruises of the MADMF and NEFSC bottom trawl surveys, the mean occurrence (fraction of tows with 1 or more individuals) and mean abundance (numbers per tow) of cod <8 cm were calculated by year and stratum. The Pearson correlation coefficient was then calculated for each possible pair of time series. A correlation was considered significant if the *p*-value was less than 0.05.

### *Evaluation of Connectivity*

In general, prevailing ocean currents within the region cause planktonic particles released in the GOM to move counter-clockwise along the coast (i.e., northward along the Nova Scotia coast, southward along the US coast) (Townsend *et al.*, 2015). A clockwise gyre on Georges Bank serves to retain pelagic particles within the GBK stratum, yet a variable portion are exported off-bank each year (Werner *et al.* 1993). Both of these currents meet at the Great South Channel (CC stratum) and move southwest into SNE (Figure 2.5). Given this general circulation pattern, it is unlikely that connectivity occurs in the “upstream” direction during early pelagic life (SNE→GOM, GBK→GOM; CC→GOM; GBK→GOM). Thus, only the remaining plausible “downstream” links (GOM→CC, SNE or GBK; CC→GBK or SNE; GBK→CC or SNE) were evaluated for evidence of early-life connectivity and assigned to one of three categories: *unlikely*, *minor*, or *major*. Although a strict quantitative criteria was not employed, “*unlikely connectivity*” is meant to represent an absence or negligible amount of connectivity between a spawning area (source) and a settlement area (sink); “*minor connectivity*” suggests that a settlement area is significantly influenced by a spawning area, but that a minority of the source’s production ends up in the sink, AND a minority of the sink’s settlement comes from that source; “*major connectivity*” suggests that a EITHER a majority of the source’s production settles in the sink, OR a majority of the sink’s settlement comes from the source.

Potential connectivity links were partly identified from a review of larval transport simulation studies. In addition, the spatial distributions of spawning, larvae, and juvenile settlement were consulted for further evidence of logical connectivity pathways. In some cases, a lack of connectivity was apparent due to a consistent near-zero probability of larval occurrence

separating a larval source and a juvenile settlement area. In other cases, multiple plumes of larval production extended over a single juvenile settlement area. To assist in determining the most plausible connectivity pathways, the size frequency information from both larval and juvenile surveys were examined for coherent developmental trajectories. Time series correlations were also consulted for further evidence that settlement in different strata could have originated from a common source.

## **Review of Cod Early Life History in US Waters**

### *Spawning*

Atlantic cod have a high potential fecundity, with individual females capable of producing several million eggs per year (Thorsen and Kjesbu, 2001). Eggs are released in multiple batches, over an extended period that may span one to two months (Kjesbu, 1989). Spawning occurs within dense aggregations (Nordeide and Kjellsby, 1999; Robichaud and Rose, 2001), yet mating takes place in pairs, following a complex sequence of behaviors (Rowe et al. 2008; Brawn 1969). Spawning is typically associated with specific seafloor features (Siceloff and Howell, 2013; Dean *et al.*, 2014), yet often involves some amount of vertical movements prior to egg release (Grabowski *et al.*, 2012). Throughout their range, cod exhibit strong fidelity to spawning sites and seasons. This has been demonstrated via multi-year observations of tagged individuals (Robichaud & Rose 2001; Skjæraasen et al. 2011; Dean et al. 2014; Zemeckis et al. 2014), as well as through persistent patterns in where and when spawning fish are caught (Morgan and Trippel, 1996; Armstrong *et al.*, 2004). However, there is ample variation across stocks with respect to the depth or time of year when spawning occurs (Brander 2005).

Several recent reviews offer a comprehensive description of the spatial/seasonal distribution of cod spawning in both the Gulf of Maine (Zemeckis et al. 2014; Ames 2004), and on Georges Bank (Decelles *et al.*, 2017). While substantial fine-scale variation exists, particularly when historical time periods are included, a clear overall seasonal pattern exists for each primary spawning ground. Within the Gulf of Maine, there are two distinct seasonal modes in spawning, each corresponding to a unique sub-population: “winter” spawning peaks in November-December, while “spring” spawning peaks in May-June. Both sub-populations spawn near the 50 m isobath in the western Gulf of Maine, primarily along the Massachusetts and New Hampshire coasts (Figure 2.6). On Georges Bank, several persistent spawning locations have been identified, yet the most productive area appears to be near the “northeast peak” of the Bank, straddling the US-Canada border. Spawning on Georges Bank appears to be more protracted than for either sub-population in the Gulf of Maine, and mainly occurs between 20 and 90 m and peaks in January-April. The cod spawning grounds west of the Great South Channel and on Nantucket Shoals (CC stratum) occur at somewhat shallower depths (20-55 m) and peak in activity November-December, several months earlier than on Georges Bank.

There are far less data available to describe the cod spawning activity southwest of Cape Cod, and what little exists have yet to be summarized or reviewed. However, a persistent winter aggregation occurs on Cox Ledge (approximately halfway between Block Island and Martha's Vineyard) that supports a burgeoning recreational fishery. Between 2007 and 2011, the University of Massachusetts (SMAST) collected maturity observations from nearly 2000 cod as part of a mark-recapture experiment in this area, representing the best contemporary scientific record of cod spawning in the SNE stratum. Most of the ripe cod observed under this effort were captured December-February (Figure 2.7).

## Eggs

The incubation time of cod eggs is directly related to temperature (Pepin *et al.* 1997; Geffen *et al.*, 2006). Consequently, the time between spawning release and hatch will vary seasonally, but likely ranges between 1-3 weeks in US waters (Thompson and Riley 1981). While the specific gravity of cod eggs does vary among populations in the Northeast Atlantic (Nissling *et al.*, 1994), it appears to be relatively homogeneous within U.S. waters (Clapp *et al.* 2013; Brander *et al.*, 2005); however, due to the seasonal, geographic, and vertical variation in temperature and salinity, the density of water in which eggs are released can be quite different (Huret *et al.*, 2007; Churchill *et al.*, 2011). Cod eggs are buoyant under most conditions and are therefore subject to epipelagic drift prior to hatching. If spawning occurs at a time of year when the water column is stratified, the eggs may become entrained near the pycnocline. During times of year without stratification, the eggs remain near the surface layer and are therefore subject to additional wind forcing and Ekman transport, further amplifying their dispersal (Lough *et al.*, 1994).

## Larvae

Upon hatching, cod larvae are approximately 4.5 mm in standard length (Bolz and Lough, 1988; Pepin *et al.*, 1997; Folkvord, 2005), although size at hatch is positively correlated with temperature (Purchase and Brown, 2000). Once exogenous feeding begins (~5.5 mm), their vertical distribution is most associated with prey availability (GrønkJaer and Wieland, 1997), with their primary prey being calanoid copepods (Friedland *et al.*, 2013). In a stratified water column, these smallest larvae (<9 mm) are most abundant within the thermocline, yet can easily be dispersed throughout by wind mixing (Lough and Potter, 1993). Although swimming capable at first feeding (GrønkJaer and Wieland, 1997), evidence of diel vertical migration (DVM) is not present until ~9 mm (Lough and Potter, 1993). During the day, larvae are broadly distributed in the water column (Lough and Potter, 1993; GrønkJaer and Wieland, 1997); at night, their vertical distribution shifts upward. The mean depth of larvae moves closer to the seafloor as they develop (Lough and Potter, 1993), and once their vertical movements begin to intersect the seafloor, they transition from pelagic planktivory to a benthic diet. This switch to benthic life is referred to as “settlement” and typically occurs at 3-5 cm (Tupper and Boutilier, 1995; Bastrikin *et al.*, 2014). The duration of each larval phase is a function of the growth rate, which in turn is dependent



upon ambient water temperature (Otterlei *et al.*, 1999; Folkvord, 2005). Given the seasonal variation in temperature in the region, the time between spawning and settlement can vary substantially between spawning groups: For GOM spring spawners, approximately 90 days separate peak spawning (~June 1<sup>st</sup>) and when 3-5 cm juveniles are first observed (~September 1<sup>st</sup>); In contrast, the time between peak spawning (~December 1<sup>st</sup>) and first observed settlement (~May 1<sup>st</sup>) is approximately 150 days for GOM winter spawners.

The geostatistical summary of more than four decades of ichthyoplankton survey data show several discrete areas of larval production that are consistent with the general description of spawning grounds provided here (Figure 2.8). Cod larvae can be found at the western end of the GOM stratum in two separate waves: December-March, and May-August. At their peak, both waves of larvae originating from the GOM extend into the CC stratum. Larvae in the SNE are present from December through May and occur most frequently toward the northern end of the stratum and near Nantucket Shoals. The single largest plume of larval production occurs on Georges Bank from January through May, with April having the highest abundance and broadest distribution. At its peak, the cloud of larvae originating from GBK extends into the southeastern corner of the CC stratum and the eastern end of the SNE stratum. Morse (1994) conducted an in-depth review of the regional distribution of cod larvae from MARMAP survey data (1977-1987) and found similar patterns to the summary provided here of the broader dataset, which includes these MARMAP data.

### *Juvenile Settlement*

Despite the broad dispersal of larvae, juvenile settlement occurs within a relatively narrow range of habitats. Recently settled juvenile cod are most abundant at depths < 30 m and where bottom temperatures are < 9 C (Grabowski *et al.*, 2018). Both laboratory experiments and survey observations reveal a preference for more complex substrates (e.g., eelgrass, kelp, rock, gravel), particularly when predators are abundant (Gotceitas and Brown 1993; Linehan *et al.*, 2001). Juvenile cod do not appear to make large horizontal movements at the beginning of their benthic life (Tupper and Boutlier 1995; Olsen *et al.*, 1994), suggesting high mortality for those individuals that do not settle over suitable habitat. As juveniles develop beyond their first year of life, they are typically found in areas adjacent to and slightly deeper than age-0 settlement habitat (Howe *et al.*, 2002; Grabowski *et al.*, 2018).

During the spring bottom trawl surveys (April-May), there appears to be a continuous area of juvenile settlement along the coast from New Hampshire to Rhode Island, at depths shallower than 100 m (GOM, CC, and SNE strata – Figure 2.9). A separate concurrent settlement zone occurs in spring over the central and western portion of Georges Bank, east of the Great South channel (GBK stratum). These 3-5 cm fish found in both settlement areas are the product of spawning that occurs over the preceding fall-winter months (October-March). During the fall surveys (September-October), recently settled juveniles are found in similar habitat in the GOM and CC strata, but are largely absent from coastal SNE and central GBK, where bottom

temperatures typically exceed 16 C, an apparent upper threshold for thermal tolerance (Figure 2.10). Some small juveniles are captured at the northeast peak of Georges Bank in fall, but these belong to the lower tail of a distribution of larger juveniles that likely represent the survivors of a single wave of GBK settlement, first observed in the spring survey (Figure 2.3).

## Conclusions on Regional Connectivity

### *GOM ↔ GOM (major self-connectivity)*

Given the regional circulation pattern, it is reasonable to assume that the recently settled juvenile cod captured north of Cape Cod originate solely from spawning events within the GOM stratum. Larval transport simulations for both spring (Churchill *et al.*, 2011) and winter (Huret *et al.*, 2007) spawning events suggest there is high potential for local retention, particularly within Massachusetts and Cape Cod Bays. This local retention appears to be strongest in spring, when spawning occurs closer to shore and wind-driven down-welling conditions prevail. Furthermore, patterns in the spatio-temporal distribution (Figures 2.8 and 2.9), seasonal abundance (Figure 2.11), and size frequency (Figure 2.12) for both larvae and juveniles corroborate two separate waves of reproduction, resulting in local settlement.

### *GBK ↔ GBK (major self-connectivity)*

Several larval transport studies describe the process of local retention of juvenile cod within the GBK stratum, particularly resulting from spawning near the “northeast peak” of Georges Bank. Eggs and larvae become entrained in the clockwise gyre and eventually settle out across the shallow central portions of the bank. Werner *et al.* (1996) estimated that approximately 80% of larval production is retained within the GBK stratum, with the deeper and more northerly distributed larvae having a higher retention probability (Werner *et al.* 1993). Larval data suggest a single wave of protracted spawning from December-June, resulting in settlement that is first observed in the NEFSC Spring bottom trawl survey (April-May). The age-0 cod captured on Georges Bank in the NEFSC Fall bottom trawl survey (September-October) are significantly larger than in the spring and likely represent survivors from this earlier wave. These larger juveniles are found primarily on the gravel-pebble habitat of the “northeast peak”, which is consistent with the expected ontogenetic habitat shift from Grabowski *et al.* (2018).

### *CC ↔ CC (unlikely self-connectivity)*

Larval transport models suggest that despite significant local retention, a substantial fraction of larvae produced in the GOM pass through the entire CC stratum in under 2 months (Huret *et al.*, 2007; Churchill *et al.*, 2011). Given the relatively small size of this stratum, prevailing southward flow, and a 2-4 month pelagic phase, it is likely that very little if any larvae produced by CC spawning would result in local settlement. Nearly all of the known spawning

grounds in the CC stratum are west of the Great South Channel and are located in the southern half of the area, all of which are more than 80 km farther *downstream* from the GOM spawning grounds (DeCelles et al, 2017).

### ***SNE ↔ SNE (major self-connectivity)***

It is assumed that all SNE spawning results in local settlement, as there are no plausible “downstream” connectivity pathways from this area. Periodic episodes have occurred where larvae and juvenile settlement were observed farther to the southwest, particularly along the southeastern shore of Long Island, NY (Morse 1994). Although this area falls outside the established management domain for US cod stocks, these settlement events are rare and most likely result from spawning in SNE.

### ***GOM ↔ GBK (unlikely connectivity)***

Larval transport simulations have shown that it may be possible for a small fraction of the larvae produced by winter or spring spawning cod in the GOM to be transported into the GBK stratum (Huret et al., 2007; Churchill et al., 2011). However, it seems far more likely that the juveniles captured on Georges Bank originate from spawning within the GBK stratum. The size of age-0 juveniles captured on GBK in the fall is significantly larger than in the GOM, suggesting they do not originate from the same source (Figure 2.12). While the size of age-0 juveniles captured on Georges Bank in the spring is similar to those in the Gulf of Maine, ichthyoplankton data suggest there is a consistent near-zero probability of larval occurrence between the GOM and GBK strata for all months (Figure 2.8) and a discontinuity in settlement areas at the Great South Channel (Figure 2.9). At the same time, there is a plume of larvae originating from Georges Bank from January through May that completely encompasses the settlement area on top of the bank. The age-0 benthic juveniles observed on GBK in April most likely result from the early portion of the protracted Georges Bank spawning season. Several GBK-focused larval transport studies further support the hypothesis of GBK self-recruitment (Werner et al., 1993; Werner et al., 1996; Lough et al., 2005), as does the lack of time series correlations between the GOM and GBK bottom trawl surveys (Figures 2.13 and 2.14).

### ***GOM ↔ CC (major connectivity)***

Within the CC stratum, cod larvae are present from November through June, several months beyond the local spawning period (October-January), suggesting that this area receives larval input from elsewhere. Larval transport studies indicate a high potential for connectivity between both spring and winter spawners in the GOM and CC (Huret *et al.*, 2007; Churchill *et al.*, 2011). In particular, some winter GOM spawning grounds may export more larvae to CC and beyond than are retained locally within the GOM. The characteristics of juvenile settlement in the CC stratum offer further evidence of a strong GOM-CC connectivity: recently settled CC juveniles are only found west of the Great South Channel, and their size distribution actually

decreases between June and September, suggesting two waves of settlement, as in the GOM. Given the assumption of no CC self-connectivity discussed earlier, it is likely that nearly all observed settlement in this stratum originates from the GOM. Further supporting this hypothesis are several significant time series correlations between GOM and CC (Figures 2.13 and 2.14).

### *GBK ↔ CC (unlikely connectivity)*

While GBK-focused transport simulations suggest high local retention on Georges Bank, a minority of larvae are exported off-bank each year; however, these exported larvae are most likely to occur at the southern fringe of the gyre (Werner *et al.*, 1996), making GBK-CC connectivity less probable (i.e., GBK-SNE connectivity is more likely). Ichthyoplankton surveys show a broad plume of larvae originating from GBK that does extend into the southeastern corner of the CC stratum, particularly in March-May (Figure 2.8). However, this larval source does not appear to extend over the CC settlement areas west of the Great South Channel (Figure 2.9). A lack of time series correlation between GBK and CC corroborates this hypothesis of unlikely connectivity.

### *GOM ↔ SNE (minor connectivity)*

As with the CC stratum, cod larvae are present in SNE well beyond the local spawning period, implying that this area also receives larval input from external sources. Simulation studies suggest that larvae from GOM spring spawning could be transported into the SNE stratum (Churchill *et al.*, 2011). However, it is clear from empirical observations of both larvae and juveniles that a spring-spawning GOM-SNE connectivity pathway is improbable: Larvae are nearly absent from this area June-September (Figures 2.8 and 2.11), and age-0 juveniles are rarely caught south of Cape Cod during the fall bottom trawl surveys (Figure 2.9). Significant fall settlement was observed in SNE only in 2004, which appeared to be an exceptionally high recruitment event for GOM spring spawning (time series high abundance for GOM, CC, and SNE).

In contrast, the longer pelagic phase of the GOM winter-spawned larvae, in addition to seasonal environmental conditions (increased wind, upwelling; cold, dense, un-stratified water column) makes broader dispersal more likely for this group. Transport potential to CC/SNE appears to be greater than local retention within the GOM for some winter spawning grounds (Huret *et al.*, 2007). Additionally, there appears to be ample suitable habitat available in SNE (< 100 m and < 16 C) at the time of year when winter-spawned larvae become settlement capable (Figure 2.9). The juveniles and larvae observed in SNE in late winter and early spring are of a similar size to those captured in GOM at the same time (Figure 2.3) and significant GOM-SNE time series correlations exist for both occurrence and abundance of settlement, further corroborating this connectivity pathway. However, there several reasons why GOM-SNE connectivity is probably of a lesser degree than the other “major” pathways: 1) There is no SNE settlement resulting from GOM spring spawning; 2) GOM winter-spawning also results in

significant settlement in GOM and CC; and 3) SNE settlement also receives contributions from spawning in CC, GBK, and SNE strata.

### ***CC ↔ SNE (major connectivity)***

Given that nearly all CC spawning areas are located west of the Great South Channel, it is unlikely that the larvae resulting from these spawning events were transported anywhere other than the SNE stratum. This is an area of high current velocity with a residual southward flow, and the long pelagic phase between spawning and settlement (2-4 months) suggests that cod eggs released at CC spawning grounds would not remain in the area long enough to contribute to local settlement. It seems equally as improbable that eggs/larvae of CC origin would be advected east (across the Great South Channel) to GBK or north to GOM. Significant CC-SNE timeseries correlations exist for both occurrence and abundance of settlement. However, it is important to note here that under the assumption that all CC settlement originates from the GOM, these correlations provide further evidence for GOM-SNE connectivity.

### ***GBK ↔ SNE (minor connectivity)***

The seasonal profile of larval abundance in both GOM and GBK strata mirror their respective spawning seasons (lagged by ~+1 month), as would be expected for areas of self-recruitment that receive no external inputs (Figure 2.11). In contrast, there are two distinct modes of larval abundance in SNE that occur both before and well after the local spawning season. The earlier mode coincides with winter-spawning in the GOM and CC, while the later mode coincides with GBK spawning, suggesting that SNE receives larval inputs from multiple areas. The spatial distribution of larvae and juvenile settlement show that GBK production does extend into the SNE stratum, which is consistent with the expected direction of the minority of larvae that are exported from GBK (Werner et al., 1996). A significant GBK-SNE time series correlation for settlement further corroborates this connectivity pathway. However, similar to the connectivity between GOM and SNE, we consider this to be a minor pathway, because: 1) SNE settlement also results from spawning in GOM, CC and SNE itself; and 2) the majority of settlement resulting from GBK spawning likely occurs within the GBK stratum.

## **Discussion**

Both the GOM and GBK strata appear to be areas of self-recruitment that receive little inputs from external sources, which supports maintaining a minimum of two stocks for managing Atlantic cod in US waters. However, there are several ways in which the current management/assessment paradigm is incongruent with the early-life connectivity between areas identified here (Figure 2.15). Multiple lines of evidence suggest that juvenile cod found in the CC stratum most likely originate in the GOM, and seasonally include the offspring of both spring

and winter spawners. It also appears likely that a portion of the juvenile settlement found in the SNE stratum originates from winter spawning in the GOM, in addition to CC, GBK, and SNE itself. Therefore, there are two connectivity pathways that cross the management boundary between current stock units: GOM-CC (major), and GOM-SNE (minor). While moving the CC stratum (statistical area 521) to the Gulf of Maine management unit would keep the major GOM-CC pathway intact, it would introduce a new issue by creating a boundary that intersects the major CC-SNE pathway. As such, it seems more biologically appropriate to combine the GOM, CC and SNE strata into a single management unit that is distinct from a GBK-only stock (at least from an early life history perspective). This would leave only a single minor connectivity pathway (GBK-SNE) to cross the management unit boundary.

In the context of observed settlement patterns, there were nine time series correlations for juvenile occurrence that cross current management boundaries (seven for abundance). Moving only the CC stratum to the Gulf of Maine management unit would yield similar results (nine for occurrence; eight for abundance). However, combining GOM, CC and SNE would represent a significant improvement (two for occurrence; one for abundance) by creating two management units with more internally-homogenous settlement patterns.

Because the international US/Canada border crosses Georges Bank, a separate process governs the assessment/management of just the eastern portion of GBK stratum that is shared between the two countries: the Transboundary Resource Assessment Committee (TRAC). This area includes the Northeast Peak of Georges Bank, which has been identified as a primary cod spawning location, and is typically used as the release location for GBK-focused larval transport simulations. These simulation studies, as well as the empirical observations from ichthyoplankton surveys, suggest that the larvae produced by cod spawning at the Northeast Peak are broadly transported across Georges Bank, crossing the western stock boundary used for TRAC assessments. Spawning occurs on Georges Bank from January through April; a few settlement-capable juveniles from the early portion of this period are also captured broadly across the bank by the spring NEFSC bottom trawl survey. However, when the fall NEFSC bottom trawl survey covers this same area several months later, a much higher quantity of larger age-0 cod are found on the gravel-pebble habitat of the Northeast Peak (and none outside the TRAC management boundaries). This suggests that the eastern portion of Georges Bank used for the TRAC process is a zone of self-recruitment, but also exports some larvae to the western GBK and SNE strata. Modifying the management boundaries for US cod stocks as outlined above (i.e., 2 stocks: GOM-CC-SNE and GBK) would have the auxiliary benefit of improving consistency with the international process that manages the shared trans-boundary resource on eastern Georges Bank.

Even though this chapter has focused exclusively on the management domain of U.S. cod stocks, it is important to consider the possibility for inputs of larvae from outside the system (i.e., adjacent Canadian waters). Cod spawn in February-March on Browns Bank, approximately 80 km to the northeast of Georges Bank (Campana *et al.*, 1989; ICES, 2005). The deep Northeast

Channel that separates Browns Bank and Georges Bank is believed to be a barrier to larval transport (Ruzzante *et al.*, 1998), and the observed spatial distribution of cod eggs, larvae, and juveniles all show a clear discontinuity between the two banks (Figures 2.8 and 2.9; Wigley & Serchuk 1992; Hanke 2000; Lough 2010). Although occasional “crossovers” of water masses from Browns to Georges Bank do occur (Bisagni and Smith, 1998; Lage *et al.*, 2004), the products of cod spawning on Browns Bank are primarily advected northward along the southwestern coast of Nova Scotia, or retained within a local gyre (Campana *et al.*, 1989; Suthers and Frank, 1989; ICES, 2005).

A review of ichthyoplankton data collected by the Canadian government in the 1970s-1990s suggest that cod also spawn near the mouth of the Bay of Fundy, along the coast of Nova Scotia (Hanke, 2000). Similar to the U.S. side of the Gulf of Maine, there are two seasonal modes to the spawning activity of this group of cod: “spring” (February-March), and “fall” (October-November) (ICES, 2005). The Canadian ichthyoplankton data suggest that most fall-spawned eggs and larvae remain in Canadian waters and are distinct from those that originate from within the U.S. management domain (i.e., west of Grand Manan Island - Hanke *et al.*, 2000). Recently settled juveniles are encountered on Browns Banks and along the southwest Nova Scotia in April, likely resulting from fall spawning along the Nova Scotia coast (Figure 2.9). In contrast, the distribution of spring-spawned cod eggs and larvae appears to extend from Browns Bank, along southwestern Nova Scotia, and across to eastern Maine (Figure 2.8; Berrien & Sibunka 1999; Morse 1994). Regardless, there is little evidence of juvenile settlement in Eastern Maine resulting from Nova Scotian spring-spawning cod (Figure 2.9). Collectively, both U.S. and Canadian ichthyoplankton data suggest that there is relatively little influx of cod larvae from the Scotian Shelf-Bay of Fundy region (NAVO div. 4x) into the U.S. management domain for Atlantic cod.

It is important to consider that the results and conclusions offered here only take into account regional patterns in early life history. Although the period of life between spawning and settlement is integral to population structure, much happens beyond the first year that is critically relevant to the definition of a stock. Our findings should be viewed in the context of the evidence presented in the remaining chapters in order to form a holistic perspective. Nonetheless, there are notable parallels between this early life history perspective on stock structure and previous genetic analyses: Kovach *et al.* (2010) found genetic similarities between winter spawning cod in the Gulf of Maine and cod west of the Great South Channel, and in southern New England. These results agree with the connectivity patterns described above. Similarly, Kovach *et al.*, (2010) noted genetic differences between cod on eastern Georges Bank and those sampled in the Gulf of Maine, Cape Cod, or Southern New England. These findings largely support the early life history information, which suggests that eastern Georges Bank is a self-sustaining population. Lage *et al.*, (2004) found genetic differences between cod on eastern Georges Bank and western Georges Bank, supporting the conclusion that connectivity from GBK to CC is

unlikely. Further, Lage et al (2004) also found evidence for reproductive connectivity between Cape Cod and Southern New England, which agrees with the results of our analysis.

We are fortunate that there have been numerous studies focused on the transport of larval cod within the region, with each providing valuable insight on the possible structure of the population. However, there are notable transport pathways that have yet to be investigated with this powerful tool. In particular, it is unclear which spawning area(s) are the fundamental drivers of the observed juvenile settlement south of Cape Cod (SNE stratum) in April/May. Studies focused on either GOM or GBK spawning grounds suggest that some larvae may be transported here; however, the fate of larvae originating from CC or SNE spawning grounds remains largely unknown. In addition, it would be interesting to explore the Cape Cod Canal as a potential GOM-SNE transport pathway, given that cod larvae and juveniles are found in the area surrounding both ends of the canal in April/May.



## References

- Ames, E. P. 2004. Atlantic cod stock structure in the Gulf of Maine. *Fisheries Research*, 29: 10–28.
- Armstrong, M. J., Gerritsen, H. D., Allen, M., McCurdy, W. J., and Peel, J. a D. 2004. Variability in maturity and growth in a heavily exploited stock: Cod (*Gadus morhua* L.) in the Irish Sea. *ICES Journal of Marine Science*, 61: 98–112.
- Bastrikin, D. K., Gallego, A., Millar, C. P., Priede, I. G., and Jones, E. G. 2014. Settlement length and temporal settlement patterns of juvenile cod (*Gadus morhua*), haddock (*Melanogrammus aeglefinus*), and whiting (*Merlangius merlangus*) in a northern North Sea coastal nursery area. *ICES*, 71: 2101–2113.
- Berrien, P., and Sibunka, J. 1999. Distribution patterns of fish eggs in the US northeast continental shelf ecosystem, 197701987. NOAA Technical Report NMFS 145.
- Bisagni, J. J., and Smith, P. C. 1998. Eddy-induced flow of Scotian Shelf water across Northeast Channel, Gulf of Maine. *Continental Shelf Research*, 18: 515–539.
- Bolz, G. R., and Lough, R. G. 1988. Growth through the first six months of Atlantic cod, *Gadus morhua*, and haddock, *Melanogrammus aeglefinus*, based on daily otolith increments. *Fishery Bulletin*, 86: 223–235.
- Campana, S. E., Smith, Stephen, J., and Hurley, P. C. 1989. An age-structured index of cod larval drift and retention in the waters off southwestern Nova Scotia. *ICES Marine Science Symposia*, 191: 50–62.
- Churchill, J. H., Runge, J., and Chen, C. 2011. Processes controlling retention of spring-spawned Atlantic cod (*Gadus morhua*) in the western Gulf of Maine and their relationship to an index of recruitment success. *Fisheries Oceanography*, 20: 32–46.
- Churchill, J. H., Kritzer, J. P., Dean, M. J., Grabowski, J. H., and Sherwood, G. D. 2017. Patterns of larval-stage connectivity of Atlantic cod (*Gadus morhua*) within the Gulf of Maine in relation to current structure and a proposed fisheries closure. *ICES Journal of Marine Science*, 74: 20–30.
- Clapp, A. R., Smith, T. R., Kovach, A. I., and Berlinsky, D. L. 2013. No differences in egg buoyancy and anti-freeze protein production in genetically divergent subpopulations of Gulf of Maine Atlantic Cod (*Gadus morhua*). *Fisheries Research*, 141: 130–135. Elsevier B.V. <http://dx.doi.org/10.1016/j.fishres.2012.05.005>.
- Dean, M. J., Hoffman, W. S., Zemeckis, D. R., and Armstrong, M. P. 2014. Fine-scale diel and gender-based patterns in behaviour of Atlantic cod (*Gadus morhua*) on a spawning ground in the Western Gulf of Maine. *ICES Journal of Marine Science*, 71: 1474–1489.
- Decelles, G. R., Martins, D., Zemeckis, D. R., and Cadrin, S. X. 2017. Using Fishermen's Ecological Knowledge to map Atlantic cod spawning grounds on Georges Bank. *ICES Journal of Marine Science*, 74: 1587–1601.

- Espeland, S. H., Gundersen, A. F., Olsen, E. M., Knutsen, H., Gjøsæter, J., and Stenseth, N. C. 2007. Home range and elevated egg densities within an inshore spawning ground of coastal cod. *ICES Journal of Marine Science*, 64: 920–928.
- Folkvord, a. 2005. Comparison of size-at-age of larval Atlantic cod (*Gadus morhua*) from different populations based on size- and temperature-dependent growth models. *Canadian Journal of Fisheries and Aquatic Sciences*, 62: 1037–1052.
- Friedland, K. D., Kane, J., Hare, J. a., Lough, R. G., Fratantoni, P. S., Fogarty, M. J., and Nye, J. a. 2013. Thermal habitat constraints on zooplankton species associated with Atlantic cod (*Gadus morhua*) on the US Northeast Continental Shelf. *Progress in Oceanography*, 116: 1–13. Elsevier Ltd. <http://dx.doi.org/10.1016/j.pocean.2013.05.011>.
- Grabowski, J. H., Conroy, C. W., Gittman, R. K., Kelley, J. T., Sherman, S., Sherwood, G. D., and Wippelhauser, G. 2018. Habitat Associations of Juvenile Cod in Nearshore Waters. *Reviews in Fisheries Science and Aquaculture*, 26: 1–14. Taylor & Francis. <https://doi.org/10.1080/23308249.2017.1328660>.
- Grabowski, T. B., Boswell, K. M., McAdam, B. J., Wells, R. J. D., and Marteinsdóttir, G. 2012. Characterization of Atlantic Cod Spawning Habitat and Behavior in Icelandic Coastal Waters. *PLoS ONE*, 7.
- Grønkaer, P., and Wieland, K. 1997. Ontogenetic and environmental effects on vertical distribution of cod larvae in the Bornholm Basin, Baltic Sea. *Marine Ecology Progress Series*, 154: 91–105.
- Hanke, A. 2000. Distribution of Atlantic cod *Gadus morhua* eggs and larvae on the Scotian Shelf. *Canadian Technical Report of Fisheries and Aquatic Sciences*, 2308: 1–146.
- Hare, J. A. 2005. The use of early life stages in stock identification studies. *In Stock Identification Methods*, pp. 89–117.
- Hare, J. A., and Richardson, D. E. 2014. The use of early life stages in stock identification studies. *In Stock Identification Methods*, pp. 329–364.
- Howe, A., Correia, S., Currier, J., King, J., and Johnston, R. 2002. Spatial Distribution of Ages 0 and 1 Atlantic cod (*Gadus morhua*) off the eastern Massachusetts coast, 1978-1999, relative to ‘Habitat Area of Special Concern’. 1-35 pp.
- Huret, M., Runge, J. a., Chen, C., Cowles, G., Xu, Q., and Pringle, J. M. 2007. Dispersal modeling of fish early life stages: Sensitivity with application to Atlantic cod in the western Gulf of Maine. *Marine Ecology Progress Series*, 347: 261–274.
- Hutchinson, W. F., Carvalho, G. R., and Rogers, S. I. 2001. Hutchinson\_2001\_microgeogr structure in cod, 223: 251–260.
- ICES. 2005. Spawning and life history information for North Atlantic cod stocks. *ICES Cooperative Research Report*, 274: 1–162.
- Kjesbu, O. S. 1989. The spawning activity of cod, *Gadus morhua* L. *Journal of Fish Biology*, 34:

195–206.

- Kovach, A. I., Breton, T. S., Berlinsky, D. L., Maceda, L., and Wirgin, I. 2010. Fine-scale spatial and temporal genetic structure of Atlantic cod off the Atlantic coast of the USA. *Marine Ecology Progress Series*, 410: 177–195.
- Lage, C., Kuhn, K., and Kornfield, I. 2004. Genetic differentiation among Atlantic cod (*Gadus morhua*) from Browns Bank, Georges Bank, and Nantucket Shoals. *Fishery Bulletin*, 102: 289–297.
- Lough, R. G., and Potter, D. C. 1993. Vertical-Distribution Patterns and Diel Migrations of Larval and Juvenile Haddock *Melanogrammus-Aeglefinus* and Atlantic Cod *Gadus-Morhua* on Georges Bank. *Fishery Bulletin.*, 91: 281–303.
- Lough, R. G., Smith, W. G., Werner, F. E., Loder, J. W., Page, F. H., Hannah, C. G., Naimie, C. E., *et al.* 1994. Influence of wind-driven advection on interannual variability in cod egg and larval distributions on Georges Bank: 1982 vs 1985. *ICES Marine Science Symposia*, 198: 356–378.
- Lough, R. G., Buckley, L. J., Werner, F. E., Quinlan, J. a., and Pehrson Edwards, K. 2005. A general biophysical model of larval cod (*Gadus morhua*) growth applied to populations on Georges Bank. *Fisheries Oceanography*, 14: 241–262.
- Lough, R. G. 2010. Juvenile cod (*Gadus morhua*) mortality and the importance of bottom sediment type to recruitment on Georges Bank. *Fisheries Oceanography*, 19: 159–181.
- Markle, D. F., and Frost, L.-A. 1985. Comparative morphology, seasonality, and a key to planktonic fish eggs from the Nova Scotian shelf. *Canadian Journal of Zoology*, 63: 246–257.
- May, A. W. 1967. Fecundity of Atlantic Cod. *Journal of the Fisheries Board of Canada*, 24: 1531–1551.
- Morgan, M. J., and Trippel, E. a. 1996. Skewed sex ratios in spawning shoals of Atlantic cod (*Gadus morhua*). *ICES Journal of Marine Science*, 53: 820–826.
- Morse, W. W. 1994. Atlantic cod, *Gadus morhua*, larvae: an analysis of the MARMAP time series, 1977-1987. 44 pp.
- Nissling, A., Kryvi, H., and Vallin, L. 1994. Variation in egg buoyancy of Baltic cod *Gadus morhua* and its implications for egg survival in prevailing conditions in the Baltic Sea. *Marine Ecology Progress Series*, 110: 67–74.
- Nordeide, J. T., and Kjellsby, E. 1999. Sound from spawning cod at their spawning grounds. *ICES Journal of Marine Science*, 56: 326–332.
- Otterlei, E., Nyhammer, G., Folkvord, A., and Stefansson, S. O. 1999. Temperature-and size-dependent growth of larval and early juvenile Atlantic cod (*Gadus morhua*): a comparative study of Norwegian coastal cod and northeast Arctic. *Canadian Journal of Fisheries and Aquatic Sciences*, 56: 2099–2111. <http://www.nrcresearchpress.com/doi/abs/10.1139/f99->

- Ouellet, P., Ouellet, P., Lambert, Y., Lambert, Y., Castonguay, M., and Castonguay, M. 1997. Spawning of Atlantic cod (*Gadus morhua*) in the northern Gulf of St Lawrence: A study of adult and egg distributions and characteristics. *Canadian Journal of Fisheries and Aquatic Sciences*, 54: 210.
- Pepin, P., Orr, D. C., and Anderson, J. T. 1997. Time to hatch and larval size in relation to temperature and egg size in Atlantic cod (*Gadus morhua*). *Canadian Journal of Fisheries and Aquatic Sciences*, 54: 2–10. <http://www.nrcresearchpress.com/doi/abs/10.1139/f96-154>.
- Purchase, C. F., and Brown, J. a. 2000. Interpopulation differences in growth rates and food conversion efficiencies of young Grand Banks and Gulf of Maine Atlantic cod (*Gadus morhua*). *Canadian Journal of Fisheries and Aquatic Sciences*, 57: 2223–2229.
- Richardson, D. E., Hare, J. A., Overholtz, W. J., and Johnson, D. L. 2010. Development of long-term larval indices for Atlantic herring (*Clupea harengus*) on the northeast US continental shelf. *ICES Journal of Marine Science*, 67: 617–627.
- Robichaud, D., and Rose, G. a. 2001. Multiyear homing of Atlantic cod to a spawning ground. *Canadian Journal of Fisheries and Aquatic Sciences*, 58: 2325–2329.
- Rowe, S., Hutchings, J. a., Skjæraasen, J. E., and Bezanson, L. 2008. Morphological and behavioural correlates of reproductive success in Atlantic cod *Gadus morhua*. *Marine Ecology Progress Series*, 354: 257–265.
- Ruzzante, D. E., Taggart, C. T., and Cook, D. 1998. A nuclear DNA basis for shelf- and bank-scale population structure in northwest Atlantic cod (*Gadus morhua*): Labrador to Georges Bank. *Molecular Ecology*, 7: 1663–1680.
- Siceloff, L., and Howell, W. H. 2013. Fine-scale temporal and spatial distributions of Atlantic cod (*Gadus morhua*) on a western Gulf of maine spawning ground. *Fisheries Research*, 141: 31–43. Elsevier B.V. <http://dx.doi.org/10.1016/j.fishres.2012.04.001>.
- Skjæraasen, J. E., Meager, J. J., Karlsen, Ø., Hutchings, J. a., and Fernö, A. 2011. Extreme spawning-site fidelity in Atlantic cod. *ICES Journal of Marine Science*, 68: 1472–1477.
- Suthers, I. M., and Frank, K. T. 1989. Inter-annual distributions of larval and pelagic juvenile cod (*Gadus morhua*) in southwestern Nova Scotia determined by two different gear types. *Canadian Journal of Fisheries and Aquatic Science*, 46: 591–602.
- Thorsen, A., and Kjesbu, O. S. 2001. A rapid method for estimation of oocyte size and potential fecundity in Atlantic cod using a computer-aided particle analysis system. *Journal of Sea Research*, 46: 295–308.
- Tian, T., Fiksen, Ø., and Folkvord, A. 2007. Estimating larval fish growth under size-dependent mortality: a numerical analysis of bias. *Canadian Journal of Fisheries and Aquatic Sciences*, 64: 554–562.
- Townsend, D. W., Pettigrew, N. R., Thomas, M. A., Neary, M. G., Mcgillicuddy, D. J., and

- O'Donnell, J. 2015. Water masses and nutrient fluxes to the Gulf of Maine. *Journal of Marine Research*, 73: 93–122.
- Tupper, M., and Boutilier, R. G. 1995. Size and priority at settlement determine growth and competitive success of newly settled Atlantic cod. *Marine Ecology Progress Series*, 118: 295–300.
- Werner, F. E., Page, F. H., Lynch, D. R., Loder, J. W., Lough, R. G., Perry, R. I., Greenberg, D. A., *et al.* 1993. Influences of mean advection and simple behavior on the distribution of cod and haddock early life stages on Georges Bank. *Fisheries Oceanography*, 2: 43–64.
- Werner, F. E., Ian Perry, R., Gregory Loughj, R., and Naimie, C. E. 1996. Trophodynamic and advective influences on Georges Bank larval cod and haddock. *Deep-Sea Research Part II: Topical Studies in Oceanography*, 43: 1793–1822.
- Wigley, S. E., and Serchuk, F. M. 1992. Spatial and Temporal Distribution of Juvenile Atlantic Cod *Gadus Morhua* in the Georges Bank Southern New England Region. *Fisheries Bulletin*, 90: 599–606.
- Zemeckis, D. R., Hoffman, W. S., Dean, M. J., Armstrong, M. P., and Cadrin, S. X. 2014a. Spawning site fidelity by Atlantic cod (*Gadus morhua*) in the Gulf of Maine: Implications for population structure and rebuilding. *ICES Journal of Marine Science*, 71: 1356–1365.
- Zemeckis, D. R., Dean, M. J., and Cadrin, S. X. 2014b. Spawning Dynamics and Associated Management Implications for Atlantic Cod. *North American Journal of Fisheries Management*, 34: 424–442. <http://www.scopus.com/inward/record.url?eid=2-s2.0-84898943241&partnerID=40&md5=e834c84a698cb655648ab3f2b00cfc74>.

## Figures

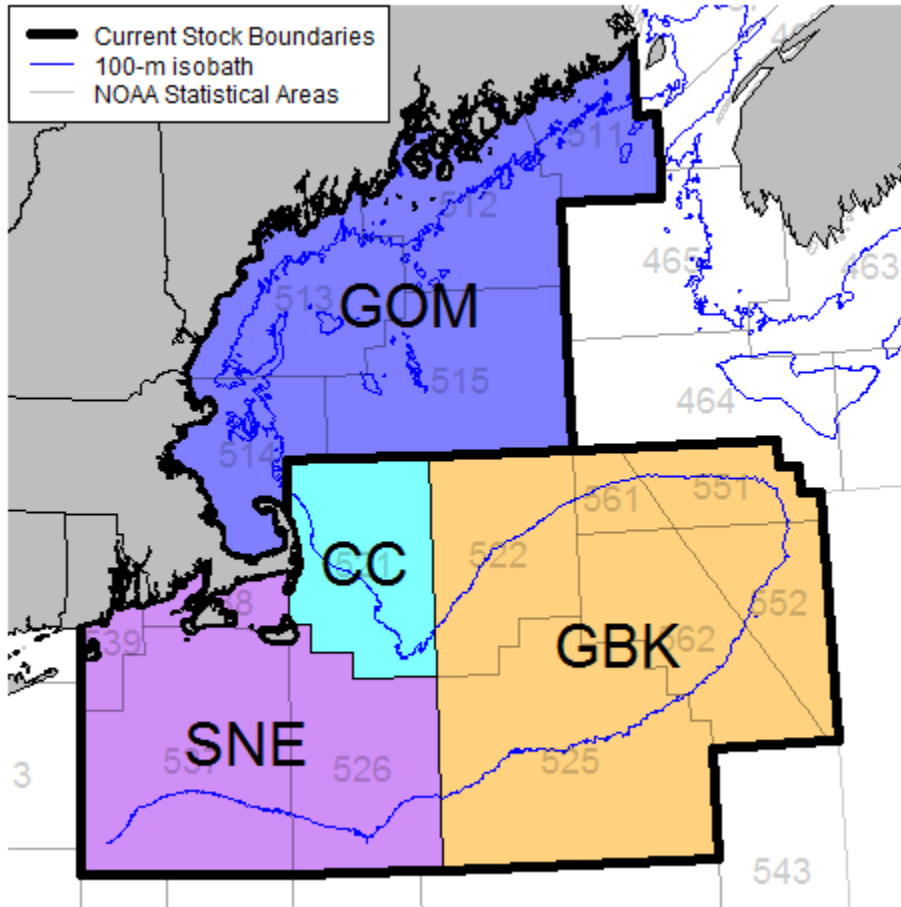


Figure 2.1. Spatial strata used for evaluating regional connectivity of cod stocks. The GOM stratum (Gulf of Maine) includes NOAA statistical reporting areas 511-514; GBK (Georges Bank) = 522, 525, 551, 552, 561, 562; CC (Cape Cod) = 521; SNE (Southern New England) = 526, 537, 538, 539.

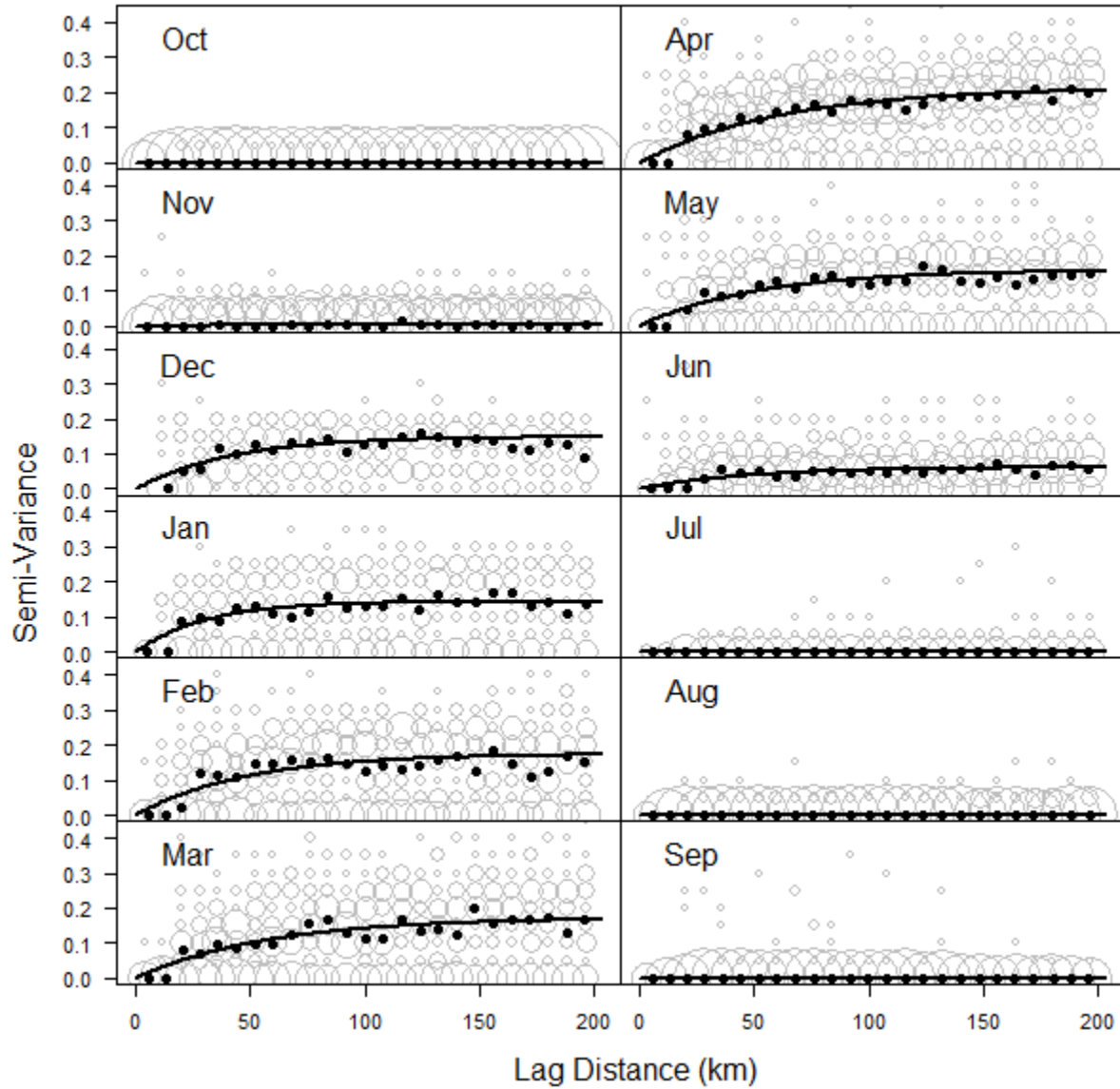


Figure 2.2. Variograms of larval occurrence used for geostatistical interpolation (i.e., kriging), by month. Hollow bubbles represent the distribution of annual empirical variogram values, where bubble size is proportional to the frequency at that level. Solid points represent the median semi-variance value for each 8 km lag bin. Solid lines represent an exponential variogram model fit to the median values.

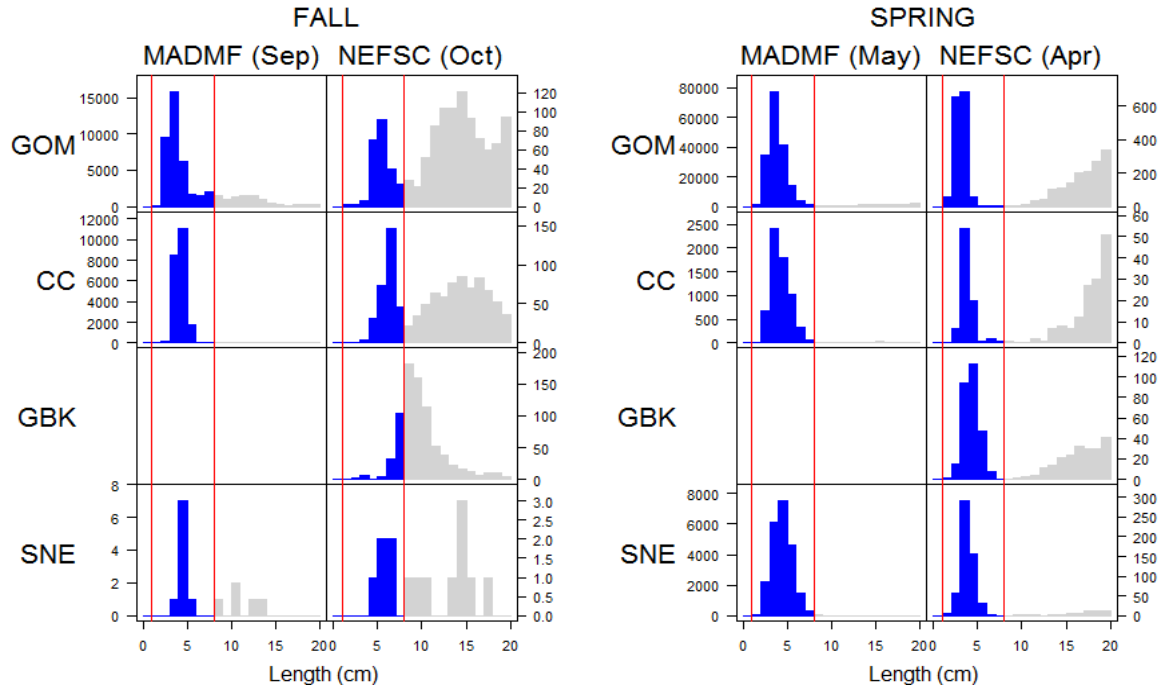


Figure 2.3. Size frequency of juvenile cod less than 20 cm, captured in NEFSC and MADMF bottom trawl surveys. The blue portion represents fish below 8 cm in total length (red vertical line) and are considered recently-settled juveniles.



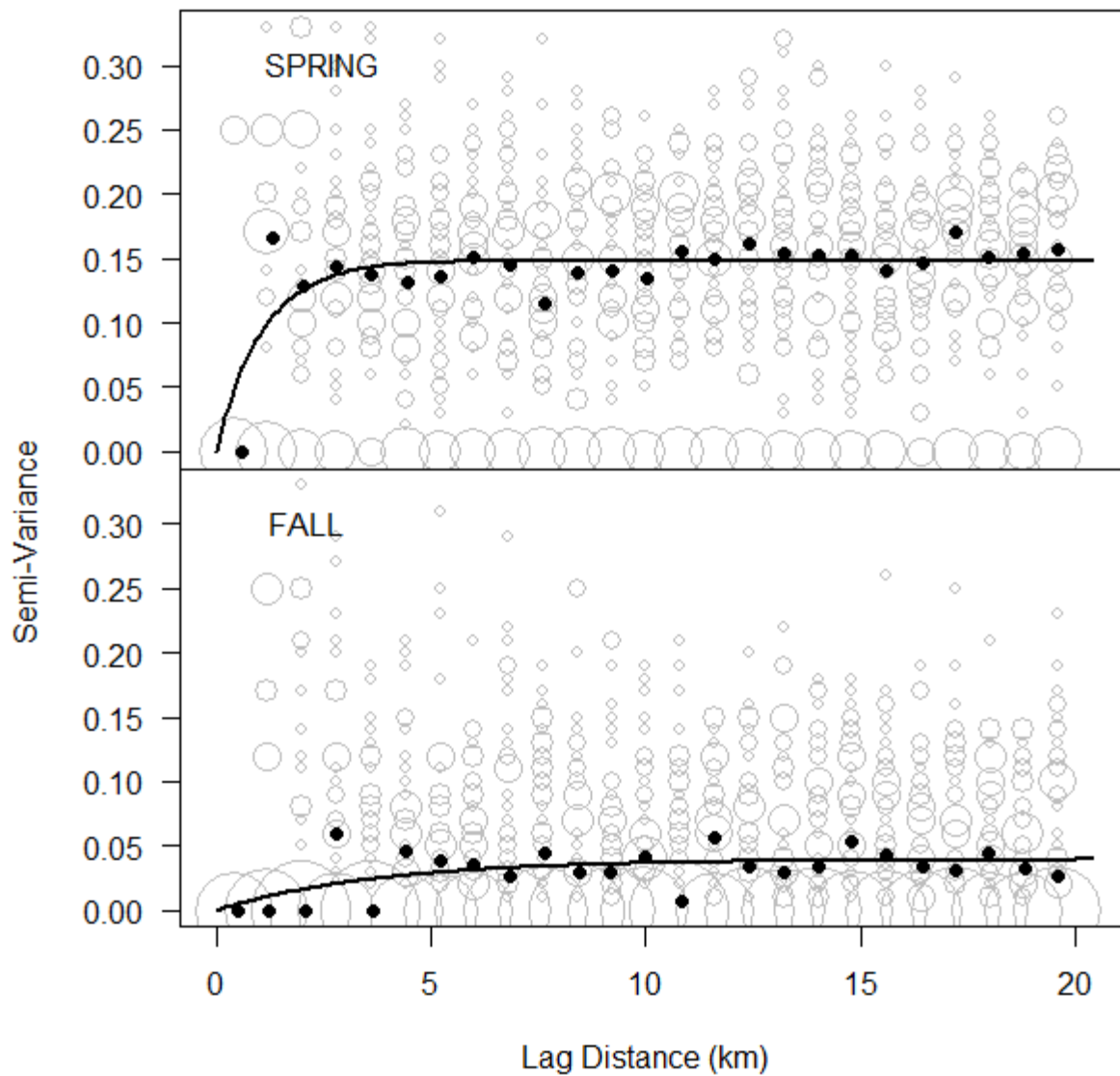


Figure 2.4. Variograms of settlement occurrence used for geostatistical interpolation (i.e., kriging), by month. Hollow bubbles represent the distribution of annual empirical variogram values, where bubble size is proportional to the frequency at that level. Solid points represent the median semi-variance value for each 800 m lag bin. Solid lines represent an exponential variogram model fit to the median values.

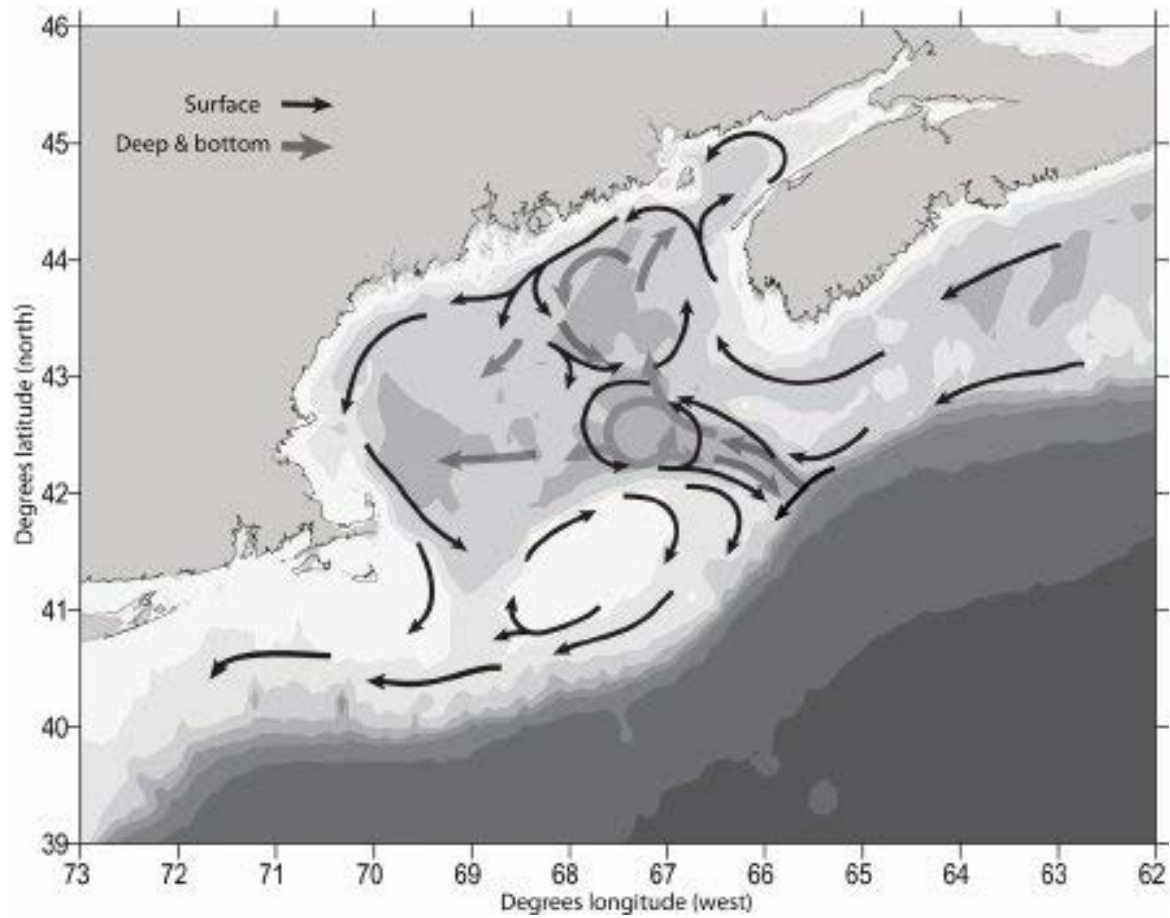


Figure 2.5. General circulation patterns in the Gulf of Maine / Georges Bank region (reproduced from Townsend et al., 2015).

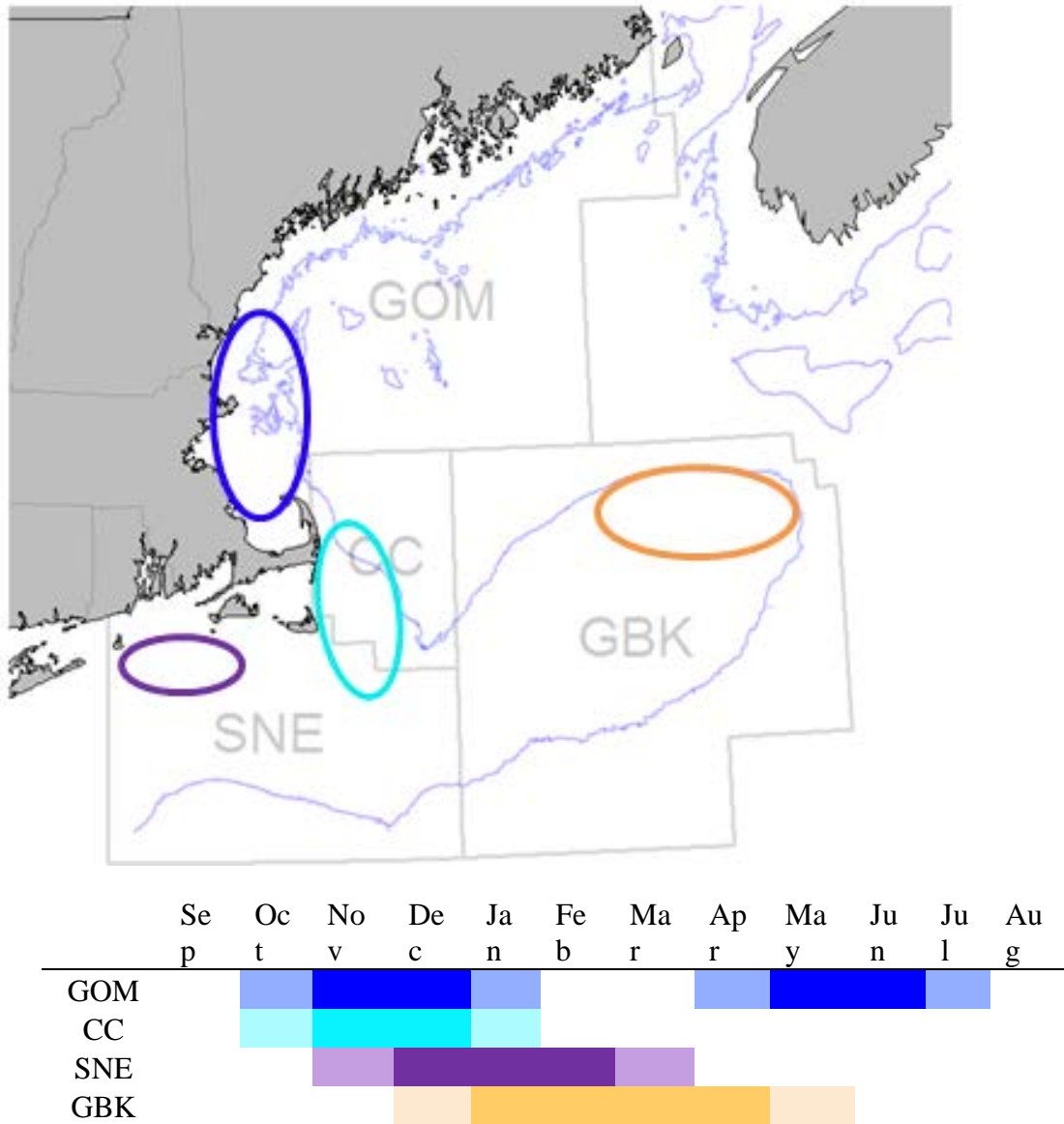


Figure 2.6. Primary cod spawning areas (top) and seasons (bottom) in US waters. It is important to note that substantial fine-scale heterogeneity is ignored here, and that this figure represents only the general pattern of contemporary cod spawning. Darker colors indicate months where spawning cod are most frequently encountered.

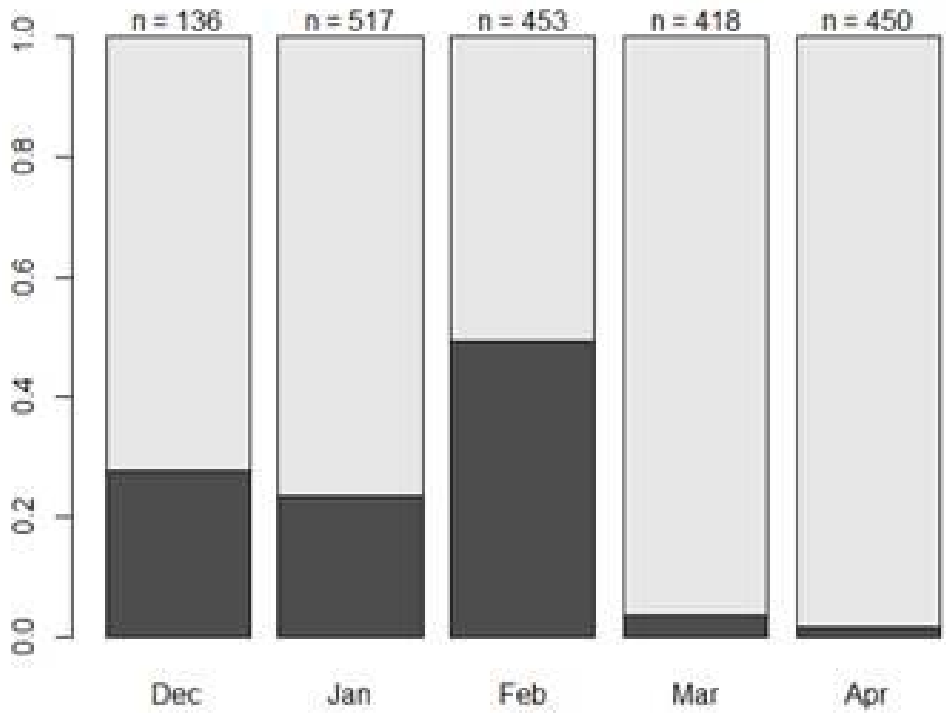


Figure 2.7. Proportion of individual cod with ripe gonads, by month, captured under the University of Massachusetts (SMAST) tagging project off southern New England, 2007-2011.

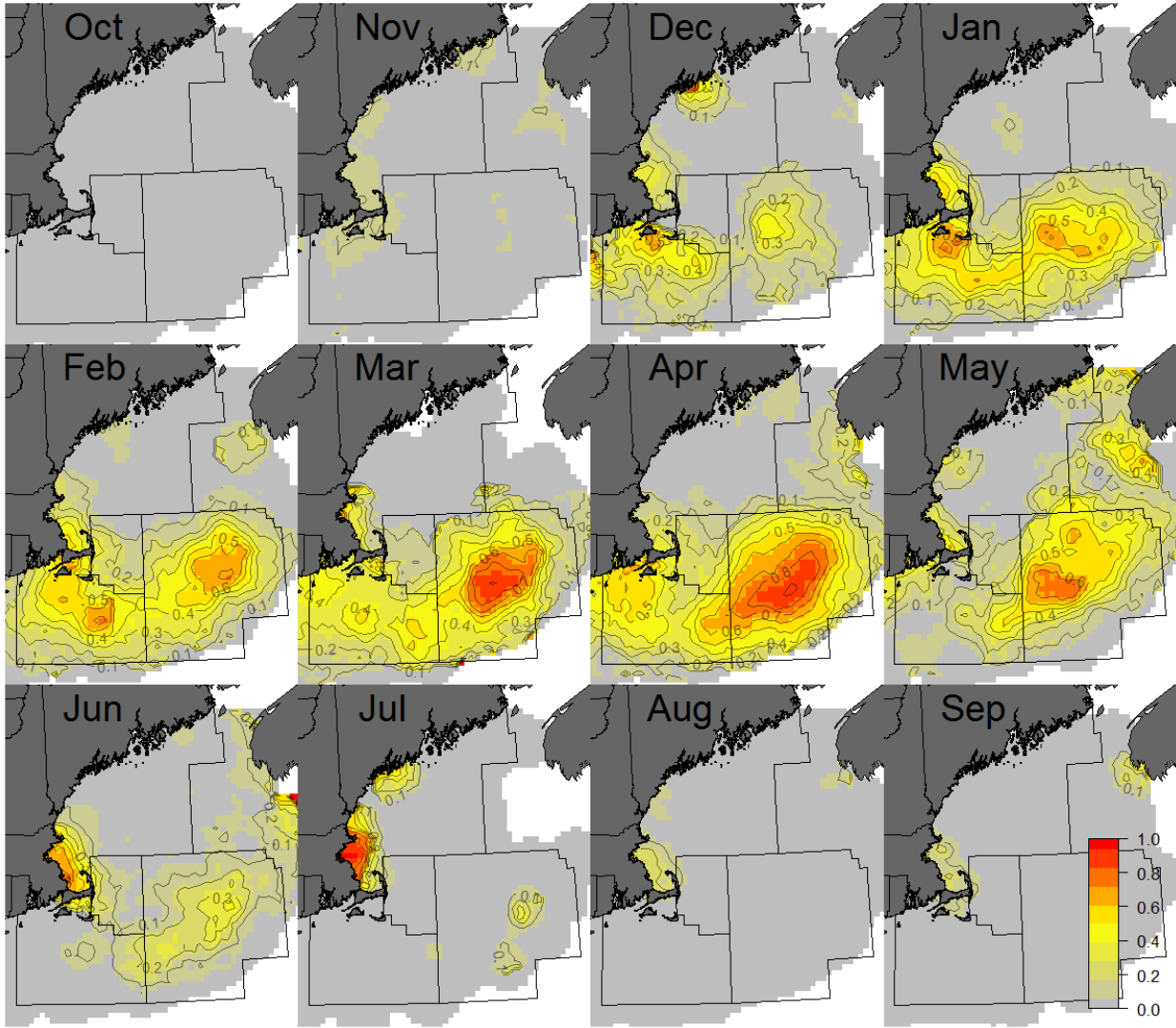


Figure 2.8. Predicted probability of occurrence of cod larvae from ichthyoplankton survey data, 1977–2017.

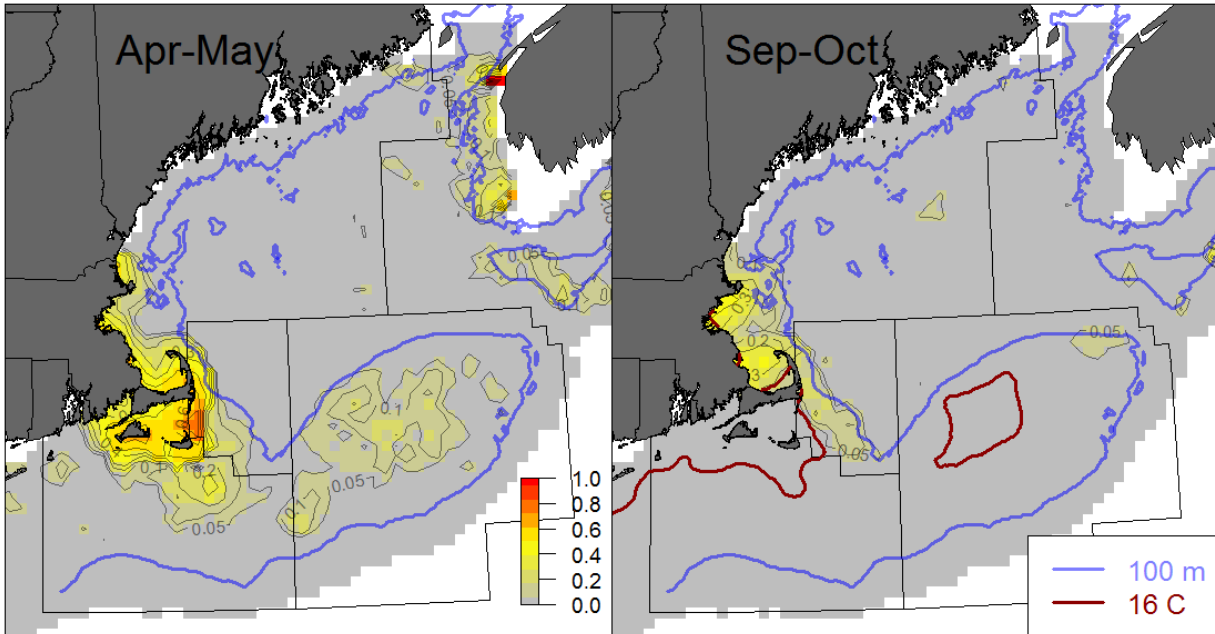


Figure 2.9. Predicted probability of occurrence of juvenile cod < 8 cm from NEFSC and MADMF bottom trawl surveys, 1963-2017. The blue line represents the 100 meter isobath. The red line represents the 16 C isotherm, as predicted by NECOFS oceanographic model in recent years (2015-2018).

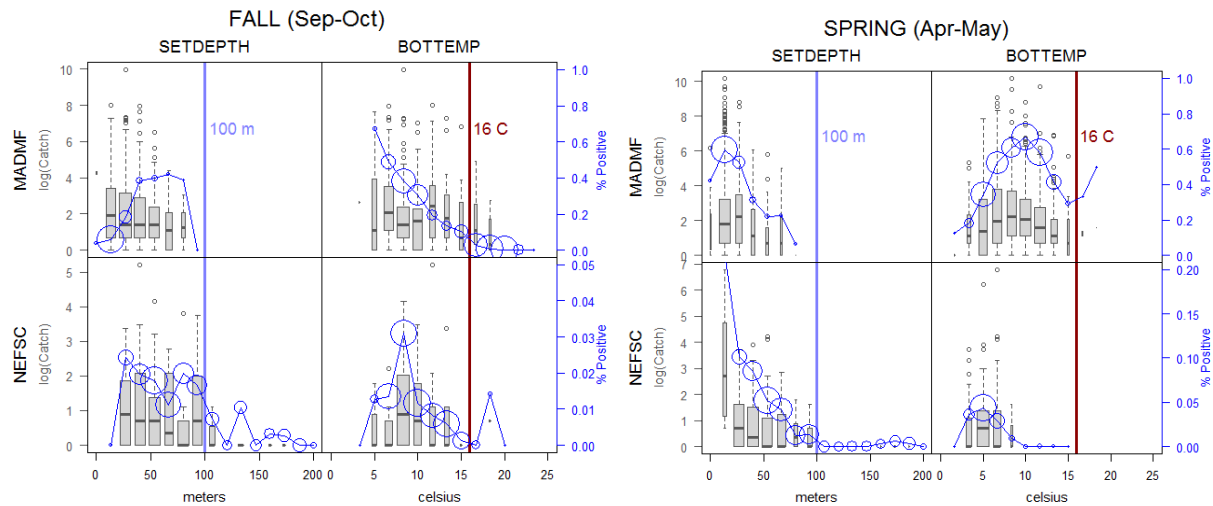


Figure 2.10. The relative abundance (gray box plots) and percent occurrence (blue lines) of recently settled juvenile cod < 8 cm, as a function of depth and bottom temperature. The width of the boxes and size of bubbles are proportional to the number of observations at that level. The dark blue vertical line represents a depth of 100 m, below which there are few juvenile cod.

Similarly, the dark red vertical line represents a bottom temperature of 16 C, which also appears to be a limit for where juvenile cod are observed.

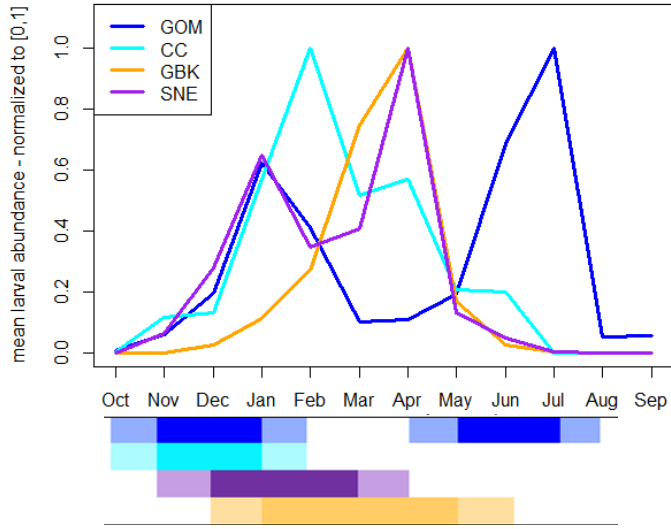


Figure 2.11. Seasonal abundance of cod larvae from ichthyoplankton surveys (above), as compared to seasonal distribution of spawning (below), by strata.

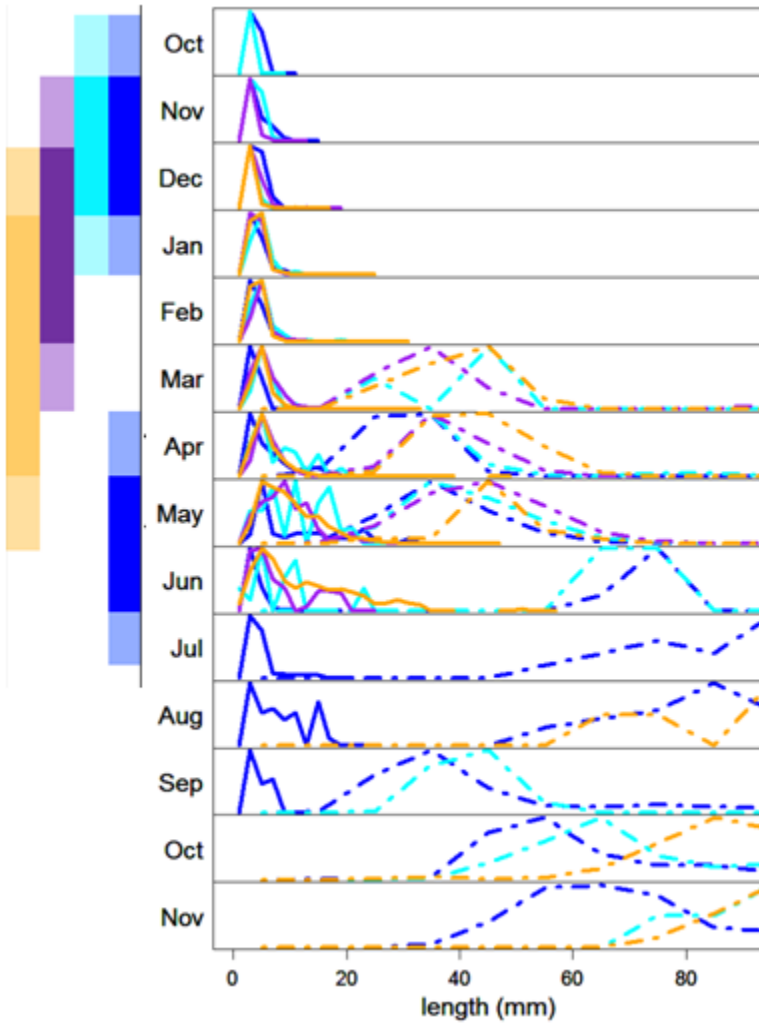
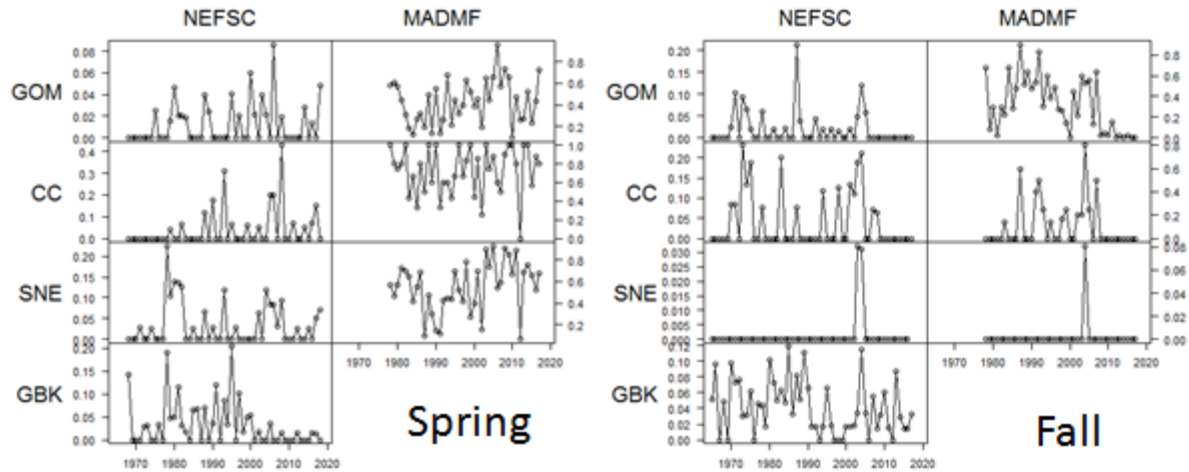


Figure 2.12. Size frequency distributions of cod larvae (solid lines) from ichthyoplankton surveys (19XX – 20X) and age-0 juveniles (dashed lines) from bottom trawl surveys (19XX-20XX), by strata. Each size frequency distribution was normalized to [0,1] to account for seasonal and spatial differences in relative abundance. The spawning season for each strata are shown at left for reference.





|         |             |             |             |             |             |             |             |              |              |              |              |              |              |              |
|---------|-------------|-------------|-------------|-------------|-------------|-------------|-------------|--------------|--------------|--------------|--------------|--------------|--------------|--------------|
| M_SNE_F | 0.07        | -0.09       | 0.23        | -0.12       | 0.01        | 0.02        | 0.13        | <b>0.41</b>  | <b>0.48</b>  | <b>0.69</b>  | <b>0.58</b>  | <b>0.11</b>  | <b>0.55</b>  | <b>1</b>     |
| M_CC_F  | -0.17       | -0.09       | 0           | -0.08       | -0.08       | -0.23       | -0.19       | <b>0.63</b>  | <b>0.43</b>  | <b>0.45</b>  | 0.19         | <b>0.6</b>   | <b>1</b>     | <b>0.57</b>  |
| M_GOM_F | -0.15       | -0.2        | 0           | 0.1         | -0.23       | -0.07       | -0.24       | <b>0.58</b>  | <b>0.28</b>  | <b>0.21</b>  | <b>0.27</b>  | <b>0.6</b>   | <b>1</b>     | <b>0.62</b>  |
| F_GBK_F | 0.04        | -0.25       | <b>0.31</b> | 0.01        | -0.28       | 0.04        | 0.05        | <b>0.29</b>  | <b>0.12</b>  | <b>0.13</b>  | <b>0.17</b>  | <b>0.37</b>  | <b>0.15</b>  | <b>0.36</b>  |
| F_SNE_F | 0.21        | -0.09       | 0.1         | -0.14       | <b>0.15</b> | <b>0.14</b> | <b>0.27</b> | <b>0.33</b>  | <b>0.47</b>  | <b>1</b>     | <b>0.33</b>  | <b>0.45</b>  | <b>0.69</b>  | <b>0.69</b>  |
| F_CC_F  | -0.01       | -0.18       | -0.03       | -0.22       | -0.01       | -0.1        | 0.13        | <b>0.48</b>  | <b>1</b>     | <b>0.47</b>  | <b>0.12</b>  | <b>0.25</b>  | <b>0.43</b>  | <b>0.48</b>  |
| F_GOM_F | -0.11       | -0.15       | 0.1         | -0.12       | -0.09       | 0.01        | -0.1        | <b>1</b>     | <b>0.49</b>  | <b>0.33</b>  | <b>0.29</b>  | <b>0.58</b>  | <b>0.63</b>  | <b>0.41</b>  |
| M_SNE_S | 0.14        | 0.17        | 0.13        | -0.1        | <b>0.43</b> | <b>0.56</b> | <b>1</b>    | <b>0.11</b>  | <b>0.19</b>  | <b>0.23</b>  | <b>0.03</b>  | <b>-0.24</b> | <b>-0.18</b> | <b>0.13</b>  |
| M_CC_S  | 0.04        | 0.18        | 0.17        | -0.03       | <b>0.4</b>  | <b>1</b>    | <b>0.55</b> | 0.01         | -0.1         | 0.14         | 0.04         | -0.07        | -0.23        | 0.02         |
| M_GOM_S | <b>0.38</b> | <b>0.58</b> | <b>0.41</b> | <b>0.06</b> | <b>0.4</b>  | <b>0.43</b> | <b>1</b>    | <b>0.09</b>  | <b>-0.01</b> | <b>0.15</b>  | <b>-0.28</b> | <b>-0.23</b> | <b>-0.08</b> | <b>0.01</b>  |
| F_GBK_S | 0.22        | 0.39        | <b>1</b>    | <b>0.33</b> | <b>0.41</b> | <b>0.13</b> | <b>0.13</b> | 0.1          | -0.12        | -0.22        | -0.14        | 0.01         | 0.1          | -0.08        |
| F_SNE_S | 0.22        | 0.39        | <b>1</b>    | <b>0.33</b> | <b>0.41</b> | <b>0.13</b> | <b>0.13</b> | 0.1          | -0.03        | 0.1          | 0.11         | 0            | 0            | 0.23         |
| F_CC_S  | <b>0.15</b> | <b>1</b>    | <b>0.35</b> | <b>0.05</b> | <b>0.34</b> | <b>0.18</b> | <b>0.17</b> | <b>-0.15</b> | <b>-0.18</b> | <b>-0.09</b> | <b>-0.25</b> | <b>-0.2</b>  | <b>-0.09</b> | <b>-0.09</b> |
| F_GOM_S | <b>1</b>    | <b>0.15</b> | <b>0.22</b> | <b>0.05</b> | <b>0.38</b> | <b>0.04</b> | <b>0.14</b> | <b>0.11</b>  | <b>0.01</b>  | <b>0.21</b>  | <b>0.04</b>  | <b>0.15</b>  | <b>-0.17</b> | <b>0.07</b>  |
| F_GOM_S | F_GOM_S     | F_CC_S      | F_SNE_S     | F_GBK_S     | M_GOM_S     | M_CC_S      | M_SNE_S     | F_GOM_F      | F_CC_F       | F_SNE_F      | F_GBK_F      | M_GOM_F      | M_CC_F       | M_SNE_F      |

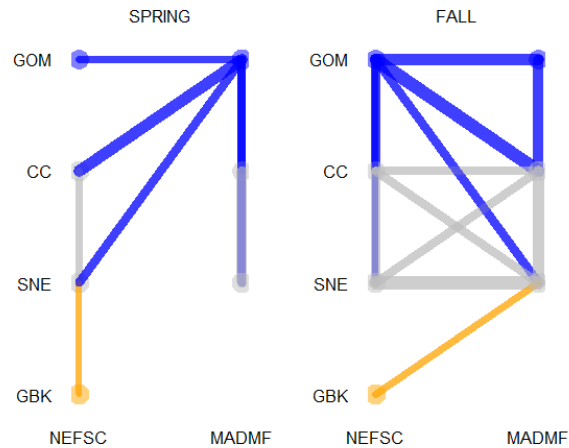


Figure 2.13. [Top row] Indices of stratified mean occurrence of juvenile cod <8 cm, by season, survey, and stratum. [Bottom left] Correlation matrix for the indices of occurrence. The first letter of each label identifies the survey (M = MADMF; N = NEFSC), the last letter the season (F = fall; S = spring), and the middle letters the stratum. Warmer colors indicate a higher correlation and bold values indicate a significant correlation ( $\alpha = 0.05$ ). [Bottom right] Visual representation of the significant correlations between survey timeseries. The width of each line is proportional to the correlation value between a pair of timeseries. Correlations with the GOM are shown in blue, whereas those with GBK are shown in orange; all others are shown in gray.

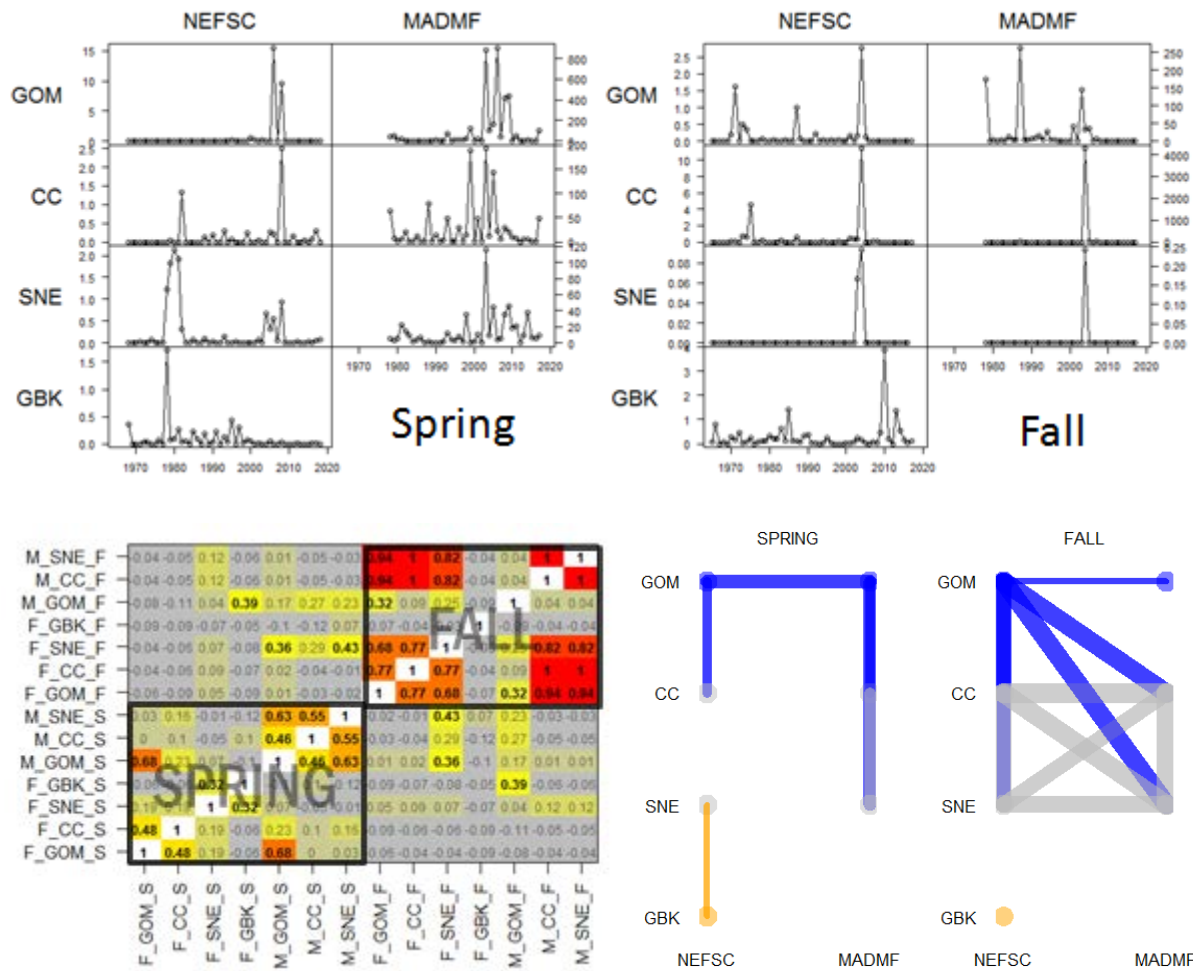


Figure 2.14. [Top row] Indices of stratified mean abundance of juvenile cod <8 cm, by season, survey, and stratum. [Bottom left] Correlation matrix for the indices of abundance. The first letter of each label identifies the survey (M = MADMF; N = NEFSC), the last letter the season (F = fall; S = spring), and the middle letters the stratum. Warmer colors indicate a higher correlation and bold values indicate a significant correlation ( $\alpha = 0.05$ ). [Bottom right] Visual representation of the significant correlations between survey timeseries. The width of each line is proportional to the correlation value between a pair of timeseries. Correlations with the GOM are shown in blue, whereas those with GBK are shown in orange; all others are shown in gray.

|      | Settlement Area |    |     |     |
|------|-----------------|----|-----|-----|
|      | GOM             | CC | SNE | GBK |
| GOMS | C               | C  | X   | X   |
| GOMW | C               | C  | c   | X   |
| CC   | X               | X  | C   | X   |
| SNE  | X               | X  | C   | X   |
| GBK  | X               | X  | c   | C   |

Atlantic Cod

C = major connectivity  
 c = minor connectivity  
 X = unlikely connectivity

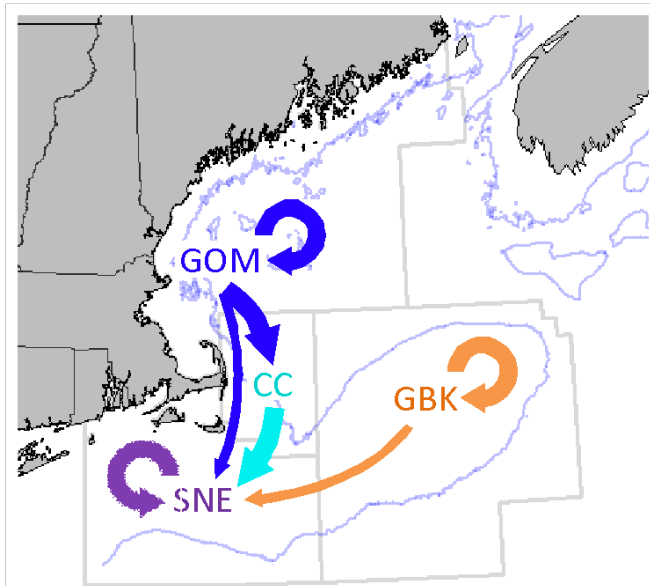


Figure 2.15. Summary of the early life connectivity between areas for Atlantic cod in US waters. “GOMS” and “GOMW” indicate spring and winter-spawning groups in the Gulf of Maine, respectively. Gulf of Maine (GOM) area: stat. areas 511-515; Cape Cod (CC) area: stat. area 521; Georges Bank (GBK) area: stat. areas 551, 552, 561, 562, 522, 525 ; Southern New England (SNE) area: stat. areas 526, 537-539.

## CHAPTER 3. GENETIC MARKERS

Adrienne I. Kovach\*, Nina Overgaard Therkildsen†, Greg Puncher‡<sup>Φ</sup>, Yanjun Wang§

\* Natural Resources and the Environment, University of New Hampshire, 56 College Road, Durham, NH 03824, USA.

† Department of Natural Resources, Cornell University, 208 Fernow Hall, Ithaca, NY 14850, USA.

‡ University of New Brunswick, 100 Tucker Drive, Saint John, NB, E2L 4L5, Canada

Φ Centre for Fisheries Ecosystems Research, Fisheries and Marine Institute, Memorial University of Newfoundland, St. John's, NL, A1C 5R3, Canada

§ Fisheries and Oceans Canada, St. Andrews Biological Station, St. Andrews, NB, E5B 2L9, Canada

### Introduction

**Genetic markers** are a powerful and widely used tool in fisheries stock identification (Cadrin 2005; Waples et al. 2008; Mariani and Bekkevold 2014). Data from genetic markers are insightful for making inferences about stock structure because they provide information about genetic similarity among individuals within and among populations. Genetic markers are temporally stable, given a robust sampling design, and are relevant therefore for making inferences about reproductive cohesiveness or isolation, which are key metrics for drawing conclusions about population structure (Waples et al. 2008).

### *Neutral and Adaptive Genetic Variation*

The majority of the variation that occurs in the **genome** is **neutral genetic variation**, which is not subject to the influence of natural selection, *i.e.*, genetic variants that do not have a direct bearing on an organism's fitness (Kimura 1983). Accordingly, variation at neutral genetic markers is influenced by the evolutionary and demographic processes of mutation, recombination, genetic drift, and dispersal/gene flow (Wright 1931). Of these processes, the latter two have the largest impact on populations over time scales relevant to fishery management; **genetic drift** acts very slowly except in small populations, leaving **gene flow** as the primary parameter of inference from studies of neutral genetic variation.

**Gene flow** (the transfer of genetic material from one population to another) in marine systems results from the combined effects of successful adult or juvenile dispersal (*i.e.*, away from the natal spawning ground) or larval drift, which is largely a function of oceanographic currents. Given its influence by these processes, gene flow is used as a measure of demographic connectivity, such that groups that are connected by high levels of gene flow are considered a population unit. However, there is no clear criterion or threshold level of gene flow that confers reproductive isolation and the levels of exchange needed to generate genetic or demographic independence may be very different. Indeed, a single individual disperser per generation can homogenize neutral genetic variation (one migrant per generation; Slatkin 1987), but populations

can be demographically independent despite much higher levels of gene flow (Waples and Gaggiotti 2006; Waples et al. 2008). Further, marine fish populations are typically characterized by large population sizes and high dispersal ability, which both lead to high levels of gene flow and subtle patterns of population differentiation (Ward et al. 1994; DeWoody and Avise 2000).

While a large fraction of the genome is believed to be neutral to selective forces, other portions of the genome are influenced by natural selection; these genome regions house **adaptive genetic variation** – variation that is associated with functional genes, the expression of which influence characteristics or traits that affect the fitness of the organism. Adaptive variation is often associated with environmental gradients (e.g., differences in temperature, salinity, or oxygen in marine environments), across which selection can act differentially on divergent phenotypes and their underlying genotypes. While fisheries management has long relied on defining management units in terms of demographic independence (i.e. using neutral genetic markers; Waples et al. 2008), considering data from adaptive genetic markers can reveal information about the ecological adaptation of populations to their local environments, which can further inform management unit designation (Schindler et al. 2010; Funk et al. 2012; Nielsen et al. 2012). Examining adaptive genetic variation therefore can aid in identifying populations with ecological distinctiveness, which is often a criterion for consideration in management contexts, including the US Endangered Species Act (Waples et al. 1991; Crandall et al. 2000).

Integrating data from both neutral and adaptive genetic markers provides a more complete picture of population structure than using either marker type alone, as it provides insight into the full suite of demographic and evolutionary processes at play. In this way, neutral and adaptive markers may group populations differently, according to the spatial patterns of drift, gene flow and selection (Funk et al. 2012). For example, it is not uncommon, especially in marine systems, for populations to show **local adaptation** in the face of relatively high levels of gene flow (Conover et al. 2006; Barth et al. 2017). As a result, interpreting data from genetic markers requires acknowledging the complexity of inference due to the different marker types and the evolutionary forces that shape them.

## *Types of Genetic Markers*

Several classes of genetic markers have been used in studies of stock structure, with technological advancements over time. In this review, we will focus on two types of markers that have been used in studies of cod populations – **microsatellite markers** and **single nucleotide polymorphisms (SNPs)**. Studies using these marker types will differ in the number of markers used and whether the markers target neutral or adaptive genetic variation.

Microsatellite markers are length polymorphisms comprised of small repetitive sequences of 2-10 nucleotides per unit (Tautz 1989). For example, a dinucleotide repeat may contain the nucleotides GT repeated in tandem a variable number of times. Individual alleles vary in the number of repeats of a given unit. Microsatellites are typically thought to be neutral, but they may also be associated with genes through physical **linkage** within a chromosome; in this case, they serve as markers of adaptive genetic variation. Because of the cumbersome technology involved in microsatellite marker development and genotyping, studies typically are limited to

the use of 8-20 microsatellite markers, although new approaches based on high-throughput sequencing recently have made it possible to efficiently genotype much larger microsatellite panels (e.g. Zhan et al. 2017, Lepais et al. 2019).

SNPs are single base differences at any position in the genome, occurring as the result of point mutations. Because they occur genome-wide, SNPs may represent either adaptive or neutral variation (Kirk and Freeland 2011). Within any genome, there will be a far greater (orders of magnitude) amount of neutral compared to adaptive SNPs. Typically, modern high-throughput sequencing technologies are used to generate data from SNP markers, enabling studies to use information from 1000s to millions of loci, depending on the amount of the genome that is sequenced (Seeb et al. 2011). **Reduced representation sequencing** – focused on a small, random (unbiased) fraction of the genome – typically generates 1000s to tens of thousands of SNPs, while **whole-genome sequencing** – literally sequencing all of the nucleotides in an organism’s genome – generates millions of SNPs (Davey et al. 2011). **Restriction-site-associated DNA (RAD) sequencing** is the most commonly used type of reduced representation sequencing to generate SNP markers for population genetic studies; it involves cutting the genome with one or more restriction enzyme and sequencing small portions of the resulting fragments (Davey et al. 2011). The large datasets generated for SNP markers require bioinformatics processing for analysis.

A third type of genetic polymorphism that occurs in some genomes is a **chromosomal inversion**. Here a segment of the chromosome remains intact as a single linked block, but is found in an inverted orientation in some individuals. In essence, the whole linked block is functioning as a single **locus** (marker), because it is inherited as a unit (due to suppressed **recombination** during meiosis), even though it is comprised of tens of thousands of SNPs.

Chromosomal inversions are known to play a role in cod population genetics, as there are four known large inversions on four different **linkage groups** (LGs; i.e. chromosomes) – LGs 1, 2, 7, and 12. These regions comprise 7% of the entire cod genome and each one contains a large number of genes (Barth et al., 2017; Berg et al., 2016, 2017; Kirubakaran et al., 2016; Sodeland et al., 2016). Polymorphisms in these chromosomal inversions have been associated with differentiation of cod populations range-wide, in both the Northeast and Northwest Atlantic. Further, these inversions have been variously associated with resident/migratory and inshore/offshore ecotypes (Berg et al., 2016, 2017; Hemmer-Hansen et al., 2013; Kess et al., 2018; Kirubakaran et al., 2016; Sinclair-Waters et al., 2017, 2018; Therkildsen et al., 2013), thermal adaptation (Barney et al., 2017; Berg et al., 2017; Bradbury et al., 2010, 2013, 2014; Therkildsen et al., 2013), salinity (Barth et al., 2017; Berg et al., 2015), and oxygen concentrations (Berg et al., 2015).

### *Genetic Sampling Considerations and Caveats*

A few sampling considerations are critical when using genetic data to make inference about stock structure for fisheries management. Firstly, for studies seeking to characterize the population genetic structure or to establish reference or baseline genotypes for future mixed stock analyses, the unit of sampling and analysis is the spawning population. That is because it is

where a fish spawns, not where it feeds or otherwise migrates to, that determines reproductive and demographic isolation among groups. Accordingly, samples must be collected in a manner that is representative of the spawning population of a given location. To achieve this, fish should be sampled as either adults in known spawning condition or as recently spawned eggs or newly hatched larvae on an active **spawning ground**. In an ideal scenario, representative samples are collected in cooperation with experienced fishermen from active **spawning aggregations** and metadata describing the exact sampling location as well as the maturity status of each individual fish are collected (e.g., Kovach et al. 2010; Kerr et al. 2018; Puncher et al. 2019). According to conventional maturity schedules used in fisheries science (Burnett et al. 1989; Morrison 1990), the maturity categories of ripe, ripe and running, or spawning are the most appropriate for this purpose, as they indicate active spawning. If actively spawning fish are not available, samples from spent (recently spawned) fish may be informative, with the caveat that it is possible that fish encountered in the spent condition have already left the spawning grounds. Fish categorized in other maturity stages (immature, developing, or resting) are not ideal for characterizing population genetic structure, given the extensive migratory movements of many marine fish during non-spawning seasons. For example, Wirgin et al. (2007) found greater genetic differences among samples of spawning cod than among opportunistic samples of other life stages, demonstrating the heterogeneity that occurs in mixed samples of non-spawning fish.

It is also important that samples are collected in such a manner as to ensure that observed genetic patterns reflect stable differences between locations, and are not shaped by spurious sampling artefacts (e.g., over-representation of particular cohorts or related individuals) or fluctuations in environmental variables that may create inter-annual variation in the spatial distribution of ecotypes (e.g., due to variation in currents affecting settlement patterns or environmental variables that change selection pressures). Within a single year, sampling should be more robust if conducted over multiple days or at least across multiple tows within a sampling location. The gold standard, however, is achieved by collecting samples in more than one year and demonstrating that the observed genetic structure is temporally stable (Waples et al. 2008, ICES 2009). Doing so requires demonstrating that the allelic differences observed among locations are meaningfully greater than that observed among years from the same location, and that the latter are not statistically significant (Waples 1998).

When spawning populations are sampled as above to characterize population genetic structure, the unit of analysis is the spawning aggregation, referenced by location and season of spawning. In some situations, there may be interest in sampling fish of unknown spawning origin as a **mixed stock** – i.e. a sample that does not target a spawning aggregation or a spawning ground, but may contain a mixed group of fish potentially from multiple spawning grounds outside of the spawning season. Analytically, such mixed collections of fish are treated differently than collections sampled from spawning aggregations. Individuals sampled in non-spawning condition or from a mixed stock can be assigned to their most likely spawning population of origin using **assignment tests** (Hansen et al. 2001; Manel et al. 2005). Alternately, **mixture analyses** can be used to determine the proportional composition of groups to designated reference populations, using baseline genotypes (Pella and Milner 1987, Anderson et al. 2008). In the absence of these formal analyses, inference about genetic composition of mixed samples may also be made from spatial clustering analyses (e.g., Principal Component Analysis, PCA, or

Discriminant Analysis of Principal Components, DAPC; Jombart et al. 2010) or Bayesian clustering methods (e.g., STRUCTURE; Pritchard et al. 2010).

Sample size considerations for genetic studies vary by marker type, number of markers used, and the extent of the genome covered by the markers. General targets for population-level sampling of spawning aggregations are 50-100 individuals for microsatellite analyses of 8-20 markers (Ruzzante 1998), 20-30 individuals for RAD sequencing analyses of a few thousand markers, and potentially as few as 10-15 individuals for whole-genome sequencing studies that typically employ a few million SNPs. Fewer individuals are needed with larger marker panels because higher information content can be generated for each individual when more independent locations in the genome are analyzed. In other words, either adding more individuals or more markers will increase the statistical power to detect differentiation among groups. Indeed, studies and simulations have shown that sufficient power to detect population differences can be achieved with as few as 8-10 individuals for >1000 SNP markers (Willing et al. 2012; Nazareno et al. 2017). However, the number of markers and individuals per population needed for robust conclusions will be influenced by the genetic diversity of the system, and, importantly, results from small sample sizes can be biased heavily due to nonrandom sampling. For this reason, in most natural populations, robust sample sizes are required for population inference. Even larger sample sizes are needed for mixed stock analyses, because this analysis uses genetic information from the whole sample and assigns it proportionally by reference population. Typically, a minimum of 100-200 individuals are required for robust mixed stock analyses. Power analyses should be conducted to demonstrate the power of this approach for population assignments with the markers and genetic polymorphism of the particular study.

## Review of Studies

In this section, we review the known studies of cod population genetic structure in US and adjacent Canadian waters, chronologically and by genetic marker type. We summarize the key aspects of study design, including geographic focus, sample size and other methodological caveats, and the key findings in relation to stock structure. Table 1 provides details of each study reviewed, including levels of genetic divergence, as measured by  $F_{ST}$ . Note that comparison of  $F_{ST}$  values across studies should be conducted with caution, given the different markers used and the variable influence of selection (Moen et al. 2008; Bradbury et al. 2013; Berg et al. 2016) and mutation (Hodgkinson and Eyre-Walker 2011) on different regions of the genome.



**Table 1.** Overview of key findings and genetic divergence, as measured by  $F_{ST}$ , for studies of cod population genetic structure in US/adjacent Canadian waters reviewed in this chapter.

| Reference            | Geographic scope   | Sample sizes   | Genetic markers  | FST values <sup>1</sup>  | Key findings <sup>2</sup> | Stock structure model supported <sup>3</sup>   | Caveats and limitations  |
|----------------------|--|--|--|--|---------------------------|--|--|
| Ruzzante et al. 1998 | Georges Bank, Browns Bank, Bay of Fundy  | 48 per location  | 5 microsatellite loci (including Gmo 132)                    | 0.011 overall (across the 3 groups)  | BSS                       | Georges Bank differentiated from Browns Bank   | Relatively small sample size and not all fish in spawning condition                        |
| Lage et al. 2004     | Nantucket Shoals (NS), Georges Bank (GB), Browns Bank (BB)                     | 97 – 144 (NS and GB); 30 (BB)                                | 5 microsatellite loci (including Gmo 132*) and Pan I         | 0.0047 overall; 0.011 Browns Bank vs. Nantucket  | BSS, NV                   | Nantucket Shoals differentiated from Georges Bank; connectivity between Georges and Browns Banks | Only 30 fish from Browns Bank; limited geographic scope and few markers.                   |
| Weiss et al. 2005    | West and east sides of Great South Channel                                     | 78 (east), 168 (west)  | 5 microsatellite loci  | 0.011  | BSS                       | Great South Channel separates Georges Bank from spawning in Cape Cod area                        | Limited geographic scope; few markers unique to this study, unknown if adaptive or neutral |
| Wirgin et al. 2007   | wGoM (spring & winter), Cape Cod, Georges Bank, and nonspawning New York Bight | 855 mixed samples; 343 spawning adults (27-100 per location) | 6 microsatellite loci (including Gmo 132, Pan I, and 2 SNPs) | 0.007 overall; 0.0095 -0.013 wGoM spring vs. winter; 0.022 wGoM spring vs. Cape Cod; 0.012 Cape Cod vs. Georges Bank | BSS, FSS                  | >1 stock within wGoM; differentiation of Cape Cod & Georges Bank                                 | Few markers, some sample sizes small; not all US spawning groups sampled                   |
| Kovach et al. 2010   | 12 spawning aggregates in wGoM, Southern New England and                       | 1581 samples (n = 31-158, with temporal replication);        | 10 microsatellite loci (including Gmo 132); Pan I, 5 SNPs    | 0.0085 spring vs. winter GoM; 0.0044 overall; 0.0011 neutral only  | BSS, FSS, NV, AV          | 3 spawning complexes: 1) northern spring-spawning coastal complex; 2)                            | No samples from western Georges Bank, Great South Channel area, eastern GoM, or            |

|                     |   |   |   |   |                      |  |   |
|---------------------|---|---|---|---|----------------------|--|---|
|                     | northeastern Georges Bank   | most in spawning condition  |   |   |                      | southern complex (winter and fall spawning in wGoM, Cape Cod and southern New England); 3) Georges Bank                                  | adjacent Canadian waters  |
| Barney et al. 2018  | Spring and winter wGoM; northeastern Georges Bank   | 10-11 individuals from each of 3 groups   | 54,030 exonic SNPs and focus on chromosomal inversions on LG 2,7,12 | 0.09 – 0.17 for pair-wise comparisons by LG 2,7, 12; 0.0001 genome-wide exonic SNPs                       | BSS, FSS, AV, CG     | Three spawning complexes are genetically distinct, with adaptive differences driven by LG 2,7,12   | Small sample sizes without metadata; exonic SNPs may be conserved (non-neutral); potential error with finding that winter-spawning wGoM are most differentiated (inconsistent with all other studies) |
| Clucas et al. 2019a | Spring and winter wGoM; northeastern Georges Bank, eastern GoM mixed fishery  | 15-24 per each of 3 groups in spawning condition and non-spawning from eGoM     | 3128 SNPs   | 0.0073 – 0.02 pairwise all loci; 0.0047 – 0.012 pairwise neutral loci only (across the 3 spawning groups) | BSS, FSS, NV, AV     | Three spawning complexes are genetically distinct; eGoM may be comprised of a mixed stock or a group of fish from nearby Canadian waters | Scope limited to the 3 spawning complexes; source of eGoM could not be resolved.  |
| Clucas et al. 2019b | 15 spawning aggregates in US waters, 2 in Canadian waters (4VsW – eastern Scotian Shelf, 3Ps – St. Pierre bank), and 3 non- | 306 samples; 11-25 (typically 15) from each of 20 spawning aggregates/locations | Nearly 11 million SNPs  | 0.011 – 0.05 pair-wise all loci; 0.0054 – 0.0017 pair-wise across groups neutral loci only                | BSS, FSS, NV, AV, CG | Five genetically distinct groups: 1) spring-spawning wGoM; 2) fall & winter spawning wGoM + Cape Cod; 3) Georges Bank; 4) southern       | Analyzed samples from wGoM, but not in multiple years, raises uncertainty about temporal stability; origins of eastern GoM could not be resolved.   |

|  |                               |  |  |  |  |                                 |  |
|--|-------------------------------|--|--|--|--|---------------------------------|--|
|  | spawning areas in eastern GoM |  |  |  |  | New England; 5) putatively eGoM |  |
|--|-------------------------------|--|--|--|--|---------------------------------|--|

<sup>1</sup> $F_{ST}$ s are not directly comparable across studies that use different markers; e.g., SNP-based estimates tend to be higher than estimates derived from microsatellites and estimates that include adaptive loci are higher than those that include exclusively neutral loci; even within a particular marker type the number and genomic region of the markers will influence the  $F_{ST}$  estimate.

<sup>2</sup>Key findings are characterized as revealing one or more of the following aspects of genetic structure: Broad-scale structure (BSS), Fine-scale structure (FSS), Neutral Variation (NV; as evidenced by statistically significant divergence at neutral  $F_{ST}$ ), Adaptive Variation (AV; as revealed by statistically significantly elevated divergence at adaptive genetic markers), Candidate genes underlying population differences (CG)

<sup>3</sup>All studies focused in US waters revealed inconsistencies with current 2-stock model; the key nature of these inconsistencies are given here, as well as the genetically distinct groupings revealed by the study.

\*Gmo 132 is a microsatellite marker known to be non-neutral, i.e. linked to a genome region under selection.

## *Studies of Population Structure with Microsatellite Markers and Pan I*

The first studies of cod population genetic structure in U.S. waters used <20 genetic markers, including microsatellites and a few targeted SNPs, such as the *Pan I* locus, which codes for an integral membrane protein, *pantophysin*, found in cytoplasmic transport vesicles and is known to be under the influence of natural selection and associated with behavioral, life history and environmental variation (Jonsdottir et al. 2008; Arnason et al. 2009). These studies primarily focused on a few sampling areas within the western Gulf of Maine, the waters around Cape Cod, and the northeastern peak of Georges Bank (Lage et al. 2004; Weiss et al. 2005; Wirgin et al. 2007; Kovach et al. 2010). With few exceptions (Lage et al. 2004), these studies were not able to address connections with adjacent Canadian waters.

Wirgin et al. (2007) sampled 855 individuals from mixed collections of larval, juvenile and adult samples from the western Gulf of Maine (GoM), Georges Bank and the Great South Channel. Analyses with seven microsatellite markers identified genetic heterogeneity within the western GoM samples, due to divergence of a mixed collection of juveniles from Massachusetts Bay. In a second phase of the study, the authors used six microsatellite loci, *Pan I*, and two additional SNPs to analyze 343 spawning adults ( $n = 27 - 100$  per location) sampled from spring and winter-spawning populations in Ipswich Bay and winter-spawning cod in Stellwagen Bank, Cape Cod (the waters offshore of Chatham, MA), and the northeastern peak of Georges Bank, as well as a non-spawning collection of cod in the New York Bight. The spring-spawning collection from Ipswich Bay was differentiated from all other spawning aggregations and the New York Bight non-spawning collection. Georges Bank was also differentiated from western GoM and Cape Cod waters, whereas there was connectivity among winter-spawners in the western GoM, Cape Cod, and the non-spawners in New York Bight. These findings were inconsistent with the 2-stock model of cod structure based on three lines of evidence: 1) genetic heterogeneity within the Gulf of Maine; 2) connectivity between western GoM and southern New England; and 3) differentiation between Georges Bank and Cape Cod.

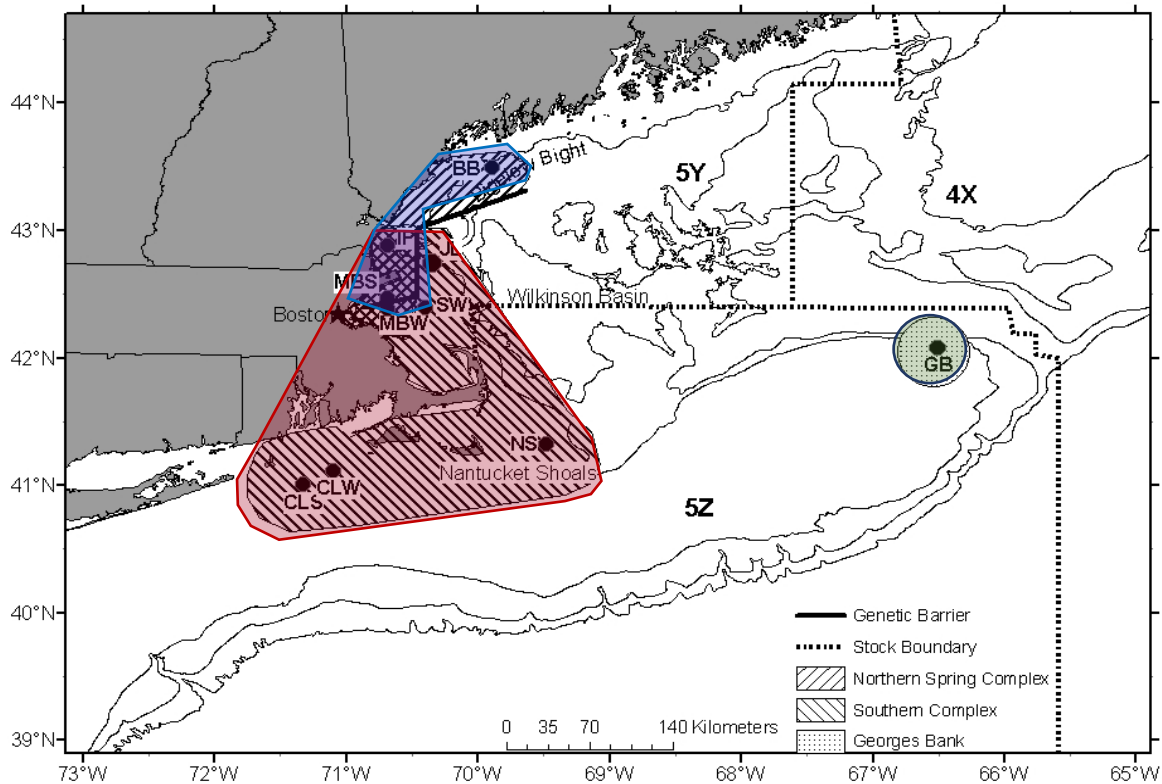
The latter finding of heterogeneity within what is considered the Georges Bank stock (Georges Bank and waters to the south, including Cape Cod, Nantucket Shoals and southern New England) was consistent with a prior study by Lage et al. (2004). Using five microsatellite markers and *Pan I*, these authors found differentiation between cod spawning on Nantucket Shoals ( $n = 97$ ) and the northeastern peak of Georges Bank ( $n = 144$ ). Further support for the differentiation of Georges Bank and the Nantucket Shoals/ Cape Cod waters is provided by an unpublished study of Weiss et al. (2005), using a different suite of five microsatellite markers than any of the aforementioned studies. This study found spawning adults sampled west of the Great South Channel ( $n=168$ ) to be genetically distinct from those sampled east of the Great South Channel on Georges Bank ( $n = 78$ ). Larvae ( $n = 46$ ) sampled west of the Great South Channel were assigned to the western spawning sampling area, while assignment of juveniles ( $n = 343$ ) was not conclusive, likely due to the mixed sample, low resolution of markers, and the small genetic differences between spawning populations.

Lage et al. (2004) also found connectivity between a spawning cod from the northeastern peak of Georges Bank ( $n=144$  across 2 years) and 30 individuals (from one year) from a spawning ground on nearby Browns Bank in Canadian waters. As part of a much larger study across

Canadian waters, Ruzzante et al. (1998) found the opposite result, using a similar suite of five microsatellite markers and sample sizes of 48 individuals. Differences in the results of these two studies may stem from relatively small sample sizes and differences in spawning condition of sampled fish (only 60% of Browns Bank cod were in spawning condition in the study of Ruzzante et al. [1998]). Two other key findings from this study may have some bearing on our interest in US waters: 1) cod south of the Laurentian Channel (Bay of Fundy, Georges Bank and Scotian Shelf) were strongly differentiated from populations to the north of it; 2) within the southern banks, three areas emerged as genetically distinct – Georges Bank, western Scotian Shelf (Browns Bank and Bay of Fundy) and eastern Scotian Shelf (Banquereau and Western Bank).

Kovach et al. (2010) expanded the work of Wirgin et al. (2007) with a comprehensive study of 1581 individuals in spawning condition (maturity stages 3-6 – primarily 4 & 5, ripe/ripe and running, with a few developing and spent fish in some collections) from 12 spawning aggregations in US waters and two collections of nonspawning cod from Platts Bank (spent and resting) and New York Bight (resting). Analyses with 10 microsatellite markers, *Pan I*, and 5 additional SNPs identified genetic structure largely consistent with three broad spawning complexes: 1) cod that spawn in the inshore waters of western GoM in the spring time (May/June) in Massachusetts and Ipswich Bays to Bigelow Bight – *the northern spring spawning complex*; 2) cod that spawn primarily in the winter, but vary in timing from November to April, in inshore western GoM in Ipswich and Massachusetts Bays, the nearshore banks of Jeffreys Ledge and Stellwagen, in Cape Cod waters of Nantucket Shoals and southern New England on Cox Ledge – *the southern complex*; 3) cod that spawn on the northeastern peak of *Georges Bank* (Fig. 1). Nonspawning adults from Platts Bank were similar to the northern spring complex and those from New York Bight were similar to the southern complex. This genetic structure was shown to be stable over a 5-year period, based on replicated samplings across 2006-2008 and comparison with the samples collected in 2003 and analyzed in Wirgin et al (2007). Further, age-0 juveniles collected in Massachusetts and Cape Cod Bays in the spring and fall could be assigned back to their spawning complex of origin. Lastly, weak differentiation of cod in Nantucket Shoals and Cox Ledge suggested the possibility for finer scale population structure beyond the three primary complexes.

The markers used in the study of Kovach et al. (2010) included two **outlier loci** known to be under the influence of natural selection. Polymorphisms at these loci have been associated with variation in temperature, depth, salinity and inshore-offshore migration patterns (Pampoulie et al. 2008). The genetic structure identified with the full suite of these markers, including the outliers, could not be recovered with the neutral markers alone, due to very small levels of neutral genetic differentiation ( $F_{ST}$  values close to zero), suggesting either recent or currently ongoing gene flow in the face of adaptive genetic differentiation. Barrier analyses, however, showed that the major genetic discontinuities were supported by a subset of the neutral loci.

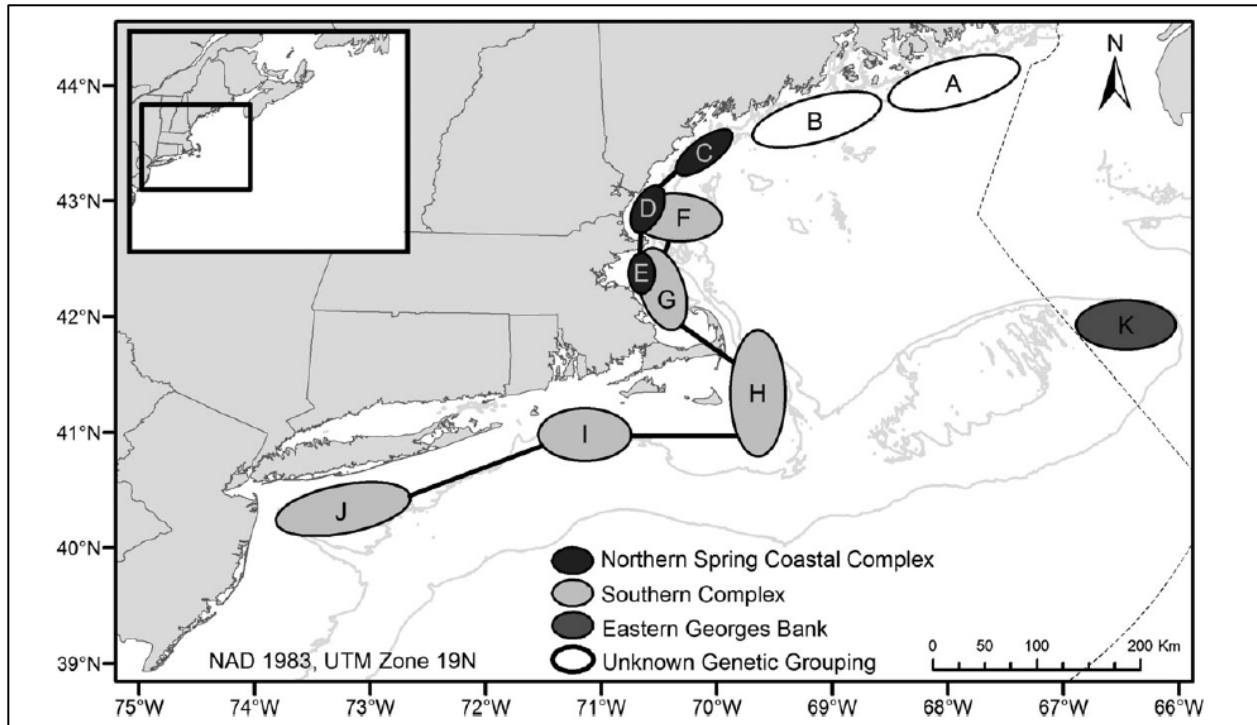


**Fig. 1.** Three genetically distinct spawning complexes identified in US waters by the study of Kovach et al. (2010), using microsatellite markers and *Pan I*. The northern spring complex, indicated by blue shaded hatching, is comprised of spawning aggregates in Massachusetts Bay (MB), Ipswich Bay (IP) and Bigelow Bight (BB) in May and June. The southern complex, red shaded hatching, is comprised of fall and winter spawning aggregates in Massachusetts Bay (MB), Ipswich Bay (IP), Jeffreys Ledge (JL), Stellwagen Bank (SW), Nantucket Shoals (NS), and Cox Ledge (CLW in December/January and CLS in March/April). The Georges Bank complex was only sampled from the northeastern peak of Georges Bank. Figure modified from Kovach et al. (2010). \*\*\*\*PERMISSION NEEDED I BELIEVE FROM MEPS (journal)\*\*\*

The findings above collectively provide evidence that

- the Gulf of Maine stock is comprised of at least two discrete populations that spawn, sometimes in the same inshore locations in the wGoM, in different seasons (winter and spring)
- there is some degree of connectivity between the western Gulf of Maine and cod that spawn offshore of Cape Cod and in southern New England
- the cod that spawn in Georges Bank are distinct from the remainder of the cod considered in that stock (those that spawn in the waters of the Cape Cod area and southern New England)
- finer scale differences may also occur among geographically separate populations, e.g. southern New England vs. Gulf of Maine;
- non-neutral markers drive the patterns of genetic differentiation, suggesting the population structure reflects differential adaptation of populations to local environmental conditions.

The collective evidence from genetic studies, summarized above, largely influenced a model of cod structure put forth in Zemeckis et al. (2014; reproduced in Fig. 2 below). This model shows the contrast with the current 2-stock management model. Nonetheless, some knowledge and sampling gaps remained at this time. In particular, 1) none of these early microsatellite studies included samples collected from the eastern GoM; 2) only one, very limited study of Weiss et al. (2005), included samples from the Great South Channel and western Georges Bank area; and, 3) with the exception of the conflicting findings of Lage et al. (2004) and Ruzzante et al. (1998), these earlier studies did not incorporate samples from adjacent Canadian waters.



**Fig. 2.** Model of cod stock structure proposed by Zemeckis et al. (2014), largely based on evidence from genetic studies using microsatellite markers and *Pan I*. The northern spring coastal complex, southern complex and eastern Georges Bank complex follow the findings of Kovach et al. (2010), with extrapolation to the New York Bight based on prior tagging studies and genetic samples of non-spawning cod. The eGoM is depicted as unknown grouping, due to a lack of data from this depleted area.

\*\*\*PERMISSION NEEDED FROM JOURNAL? OTHER CHAPTERS USE THIS FIGURE TOO?\*\*\*

### *Studies of Population Structure with Genome-wide SNPs*

A series of recent studies, using more powerful panels of SNPs leveraged from high resolution genomic methods, have largely confirmed the patterns identified in the above-described microsatellite and *Pan I* studies and provide additional insights into the complexity of cod population structure. In the first of these studies, Barney et al. (2017) focused primarily on the regions of the genome found in the known chromosomal inversions on LG 2, 7 and 12, which had been previously shown to differentiate cod populations broadly within the Northeast and

Northwest Atlantic (Bradbury et al. 2014). Barney et al. (2017) were the first to show these inversions to be polymorphic within the GoM and Georges Bank area. The authors used whole-genome sequencing and extracted 54,030 exonic SNPs (found in the coding regions of the genome, termed exons) for their population analyses. Of those SNPs, 33,915 were found in LGs 2, 7 and 12, both within and outside of the LD blocks containing the chromosomal inversions, and 20,115 were found elsewhere in the genome. These SNPs were used to evaluate 10-11 individuals sampled from each of the three spawning groups identified in Kovach et al. (2010) – winter and spring spawners in western GoM and cod spawning on Georges Bank. The authors found that adaptive variation played a key role in differentiating the winter and spring spawning populations in the western GoM and those on Georges Bank. They found candidate genes linked to temperature associated physiological differences and a large number of such genes on LG 2 that differentiated the winter and spring spawning populations.

While the overall finding of adaptive genetic differentiation among the three spawning groups corroborated other studies, one inconsistency in the findings of Barney et al. (2017) was that of greater genetic differentiation of the winter spawning population from the other two. All other studies of these populations – Wirgin et al. (2007), Kovach et al. (2010) and Clucas et al. (2019a,b – see below) – have found the spring spawning population to be the most genetically divergent within these waters. This inconsistency in the study of Barney et al. (2017) may be a result of small sample sizes ( $n=10-11$ ), which may have led to imprecise estimates of allele frequencies. Additionally, metadata were unavailable describing the reproductive maturity of the sampled fish. Barney et al. (2017) also found no evidence for neutral differentiation among these three populations, with very small  $F_{ST}$  values, suggesting complete **panmixia**. The study's use of exonic SNPs for estimating neutral divergence makes it difficult to compare with neutral estimates of other studies that include SNPs from noncoding portions of the genome. That is, due to selective constraints (exons are conserved regions of the genome subject to purifying selection, which reduces genetic variation), exonic SNPs are less likely to show patterns of population differentiation unless they are under strong divergent selection.

Using RAD sequencing, Clucas et al. (2019a) identified a panel of 3128 SNPs randomly distributed across the cod genome, which they used to analyze genetic variation across winter and spring spawning populations in Ipswich and Massachusetts Bays, cod spawning on the northeastern peak of Georges Bank, and a nonspawning population of cod sampled from the Maine Center for Coastal Fisheries' Sentinel Hook Survey in the eastern GoM (Henry 2013, Rodrigue 2017). The latter provided the first genetic evaluation of cod in this depleted region of the eastern GoM, where aggregations of spawning cod have not been observed since the 1990s. Analyses of 15-24 cod per population showed clear support for divergence between the winter and spring spawning populations in the western GoM, as well as fine-scale differences between cod spawning in the two bays within the same season. Cod spawning on the northeastern peak of Georges Bank were differentiated from both spawning populations in the western GoM, and the spring spawning population was the most divergent overall. The cod sampled from the Sentinel Survey in the eastern GoM could not be decisively linked to either of the three spawning groups, suggesting a few possible hypotheses: that this sample may represent a genetically distinct population, a mixed sample, or cod that migrated to the eastern GoM from Canadian waters. The non-spawning condition of these fish preclude firm conclusions about the population genetic structure of the eastern GoM.



As was true of the earlier studies described in 3.3.1. above, most of the genetic differentiation revealed by the 3128 SNPs in Clucas et al. (2019a) was driven by non-neutral loci. When 47 outlier loci (SNPs with statistically significantly elevated levels of divergence as measured by  $F_{ST}$ ) and another 106 SNPs located in the chromosomal inversions on LG 2, 7, and 12 were removed, the genetic differences (magnitude of  $F_{ST}$ ; see Table 1) were much smaller and the patterns of structure weaker; however, the differences among the three primary groups – winter GoM, spring GoM and Georges Bank – were recovered by discriminant analysis of principal components (DAPC). The three LGs factored strongly in shaping the genetic patterns in this study, primarily in differentiating spring-spawning western GoM from both winter-spawning western GoM and Georges Bank. Identification of 47 additional outlier loci suggested that other portions of the genome may also be important in differentiating these population.

In the largest scale genomic study of cod population structure to date, Clucas et al. (2019b) used nearly 11 million SNPs recovered from **low-coverage whole-genome sequencing** of 306 individuals from 20 sampling locations, including all known spawning aggregations in US waters and two locations in nearby (but non-adjacent) Canadian waters. All samples were collected from actively spawning (or recently spawned) fish, except those in the eastern GoM. US spawning samples included 8 spawning aggregations in the western GoM – four spawning in winter and four in spring, three areas in the waters offshore of Cape Cod, on the Nantucket Shoals, and the Great South Channel, two in southern New England on Cox Ledge, one on the western most edge of Georges bank just east of the Great South Channel, and one on the northeastern peak of Georges bank. Samples collected from non-spawning cod were also analyzed from three areas in the eastern GoM – midcoast in the Penobscot Bay area, inshore in the eastern most portion of the GoM, and offshore in the eastern GoM. Canadian spawning aggregations were sampled on either side of the Laurentian Channel – on the eastern Scotian Shelf and on St. Pierre Bank, offshore of Newfoundland.

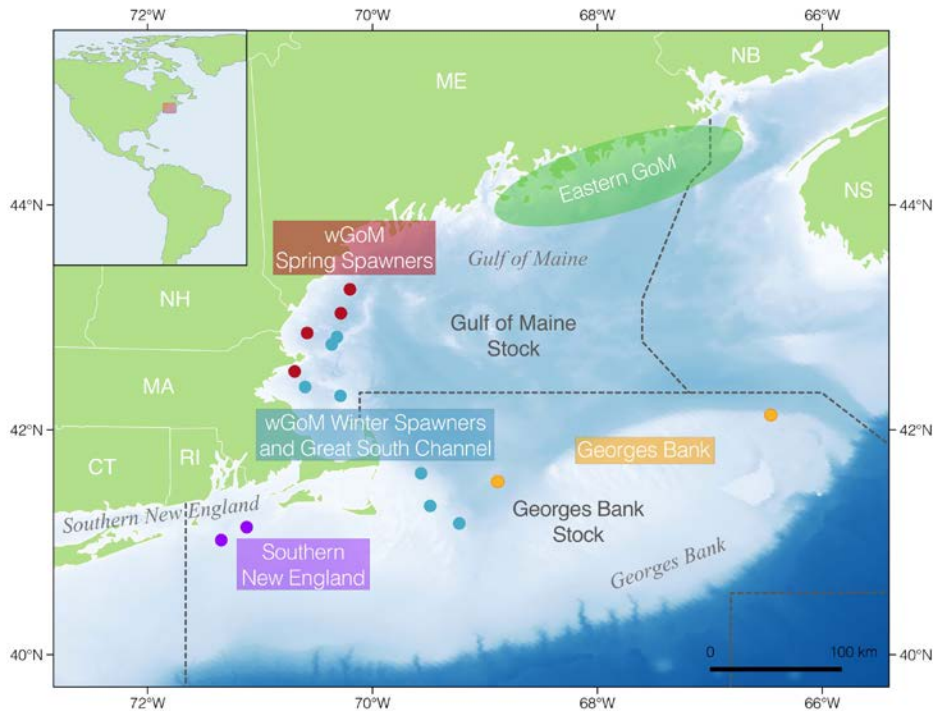
The findings of Clucas et al. (2019b) revealed complex patterns of population structure driven largely by regions of the genome likely to be under natural selection. Using the allele frequencies from all polymorphisms across the whole genome in a PCA, resulted in clustering of populations as follows. Within US waters, the spring spawning populations in the western GoM clustered distinctly from the winter spawning populations, and winter and spring spawners from the same bays (Ipswich and Massachusetts Bays) clustered more clearly by their spawning season rather than geographic location. Cod sampled from the Cape Cod/Nantucket Shoals/Great South Channel area clustered with the winter spawners in the western GoM, but cod in southern New England clustered separately and were positioned at the far end of the first principal component axis. Cod sampled from eastern and western Georges Bank were positioned proximate to one another in the PCA, and intermediate to the winter and spring spawners in the western GoM, albeit nearer to the winter spawners. Nonspawning cod collected in the eastern GoM showed some variability, but clustered largely with winter spawners in the western GoM and those in the Cape Cod region. Cod sampled in Canadian waters were the most distinct from all populations in US waters and from each other.

The observed genetic structure was driven largely by the four chromosomal inversions (LGs 1, 2, 7 and 12), as a PCA generated solely from haplotype frequencies of these four inversions

appeared very similar to the whole genome PCA. However, when examined separately, these four LGs did not group the populations in exactly the same way. In particular, LG1 largely differentiated the two Canadian populations from all populations in US waters, while at LG 2, 7, and 12 the spring-spawning western GoM group showed more similarity to the Canadian samples than the other US samples. There were also subtle differences in the grouping of Georges Bank and southern New England across these three LGs pointed to some finer-scale structuring in these regions.

Elevated genetic divergence was also found in several other regions of the genome outside of the chromosomal inversions. The polymorphisms within these differentiated regions of the genome were associated with several **candidate genes** with known functions that may play a role in adaptive differences of these population groups. In particular, two hormone receptor genes (FSHR, follicle stimulating hormone receptor and ESR2, an estrogen receptor) were found to be highly differentiated between the spring-spawners in the western GoM and all other populations, except the Canadian samples from St. Pierre Bank, which also spawn in the spring time. Clucas et al. (2019b) suggested that this genetic difference may underlie a mechanism for the difference in spawning time of these populations. Another potentially relevant polymorphism occurred in a region that contained two heat shock protein genes, known to play a role in thermal tolerance. This region differentiated the Southern New England samples from other cod populations in a clinal fashion, suggesting differentiation in local adaptation of cod in thermal tolerance along a latitudinal temperature gradient. In summary, the whole genome analysis of Clucas et al. (2019b) highlighted the role of adaptive genetic variation in driving population differentiation and showed that different parts of the genome distinguished populations differently, suggesting complex patterns of adaptive diversity contribute to **biocomplexity** of cod population structure.

Clucas et al. (2019b) concluded that there are 4 or 5 genetically distinct groupings of cod in US waters as follows: 1) spring-spawning western GoM; 2) winter-spawning cod in western GoM and fall and winter-spawning cod in the Cape Cod and Nantucket Shoals area, including the western part of the Great South Channel (statistical area 521); 3) cod spawning on western and eastern Georges Bank; 4) southern New England waters (coastal areas south of the Cape Cod/Great South Channel area); and 5) potentially the eastern GoM, with the caveat that conclusions could not be reached in the absence of data from spawning cod in this area (Figure 3). When the adaptive loci (polymorphisms in the chromosomal inversion regions and the additional outlier regions of the genome) were removed from the dataset, the remaining neutral datasets showed very little differentiation among populations, however, differences among these major groupings were upheld. Neutral loci also indicated some gene flow between Georges Bank and the Cape Cod/Nantucket Shoals/Great South Channel area, which was not apparent with the adaptive loci. While this study is the most robust to date, in terms of sampling effort – extensive sampling of cod in spawning condition from the major known spawning aggregations – and a comprehensive genome-wide set of markers used, a few limitations remained. First, the 15 samples from the western Georges Bank were from a single year and therefore the study was unable to demonstrate temporal stability (in contrast, other regions in this study had been sampled in multiple years in prior work, and those prior analyses demonstrated temporal stability). In addition, the genetic composition of the eastern GoM remains unresolved until data from spawning or larval cod are available from this region.



**Fig. 3.** Model of cod population structure put forth in Clucas et al. (2019b). Four genetically differentiated spawning groups are indicated with color coding as follows: 1) western GoM spring – Massachusetts Bay, Ipswich Bay, and Bigelow Bight; 2) western GoM winter plus Cape Cod – Massachusetts Bay, Ipswich Bay, Jeffrey’s Ledge, Stellwagen Bank, Cape Cod, Nantucket Shoals and Great South Channel; 3) Georges Bank – western Georges Bank, east of the Great South Channel, and Northeast Peak; 4) southern New England – Cox Ledge. The circled area comprising eastern GoM is a fifth potentially distinct population, although the data from spawning cod are lacking to resolve this. Dotted lines depict current management unit boundaries. **\*\*\*PERMISSION WILL BE NEEDED FROM EVOLUTIONARY APPLICATIONS\*\*\***

Recent findings from another study using >5000 SNPs (RAD sequencing) provides evidence of transboundary gene flow across the US and Canadian border (Puncher et al. in prep.). That study also revealed an eastern corridor of connectivity linking the Bay of Fundy with Browns Bank and eastern Georges Bank. This latitudinal path of gene flow is similar to the corridor of movement identified in the west that links the winter spawning cod of the wGOM with Cape Cod and the Nantucket Shoals. Another preliminary finding from that study is the clustering of samples from the western Georges Bank (near 68W) near samples from the Great South Channel. Given the contrast with the results of Clucas et al. (2019b), these findings suggest that western Georges Bank may be a mixing area, and different collections of samples may represent genetically different groups of fish. Alternatively, it is important to note, that even including these two studies, sampling of the western Georges Bank has been sparse and temporally unreplicated.

In summary, the findings of studies from genome-wide SNPs largely build upon the earlier microsatellite studies summarized in 3.3.1. They provide higher resolution and reveal additional details about the complexity of population structure, with the following key points:

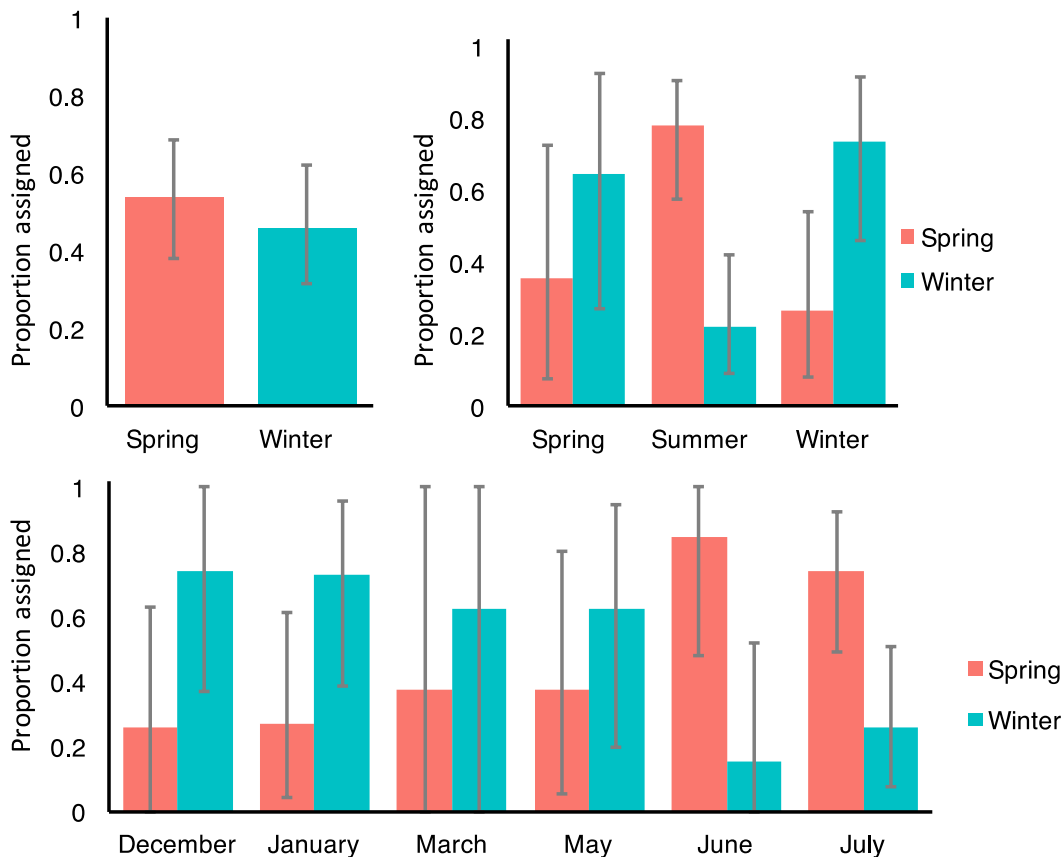
- There is a greater complexity of population structure than recognized by the US 2-stock model, with at least 4 genetically distinct spawning aggregations in US waters.
- Spring-spawning cod in the western GoM are the most genetically distinct from all other cod spawning in US waters, including winter-spawning aggregations in the same inshore bays, and share some similarities with more northern Canadian populations, particularly those that also spawn in the spring.
- Genetic differentiation is driven primarily by regions of the genome under the influence of natural selection; some of these genome regions hold genes with ecological or physiological functions (reproduction, thermal tolerance) that differ among populations. Different parts of the genome group spawning populations differently, so these complex patterns of adaptive differentiation across the genome suggest multifaceted selection pressures and local adaptation among spawning populations.
- When the adaptive portions of the genome are excluded, neutral loci alone reveal a much lower amount of divergence, but support differentiation among the main population groupings.

### *Mixed Stock Analyses*

Relatively little attention has been given to the assignment of mixed stock fisheries to spawning population of origin in US waters, compared to the above described work on population structure. One study focused on assigning fish from a modern GoM commercial fishery to either winter or spring-spawning western GoM populations (Kerr et al. 2018, unpublished report). First, temporal stability was demonstrated by comparing a sample of 160 spawning cod sampled on the spawning grounds in 2014-2015 (samples distributed across Ipswich and Massachusetts Bays in the winter and spring) with 274 archived samples from Kovach et al. (2010), collected in 2006-2008 from the same two bays and spawning seasons. Datasets generated from 12 microsatellite markers were compared across the 2 time periods. Significant genetic differentiation, as measured by pair-wise  $F_{ST}$  and Analysis of Molecular Variance, was found for all comparisons of winter and spring spawning groups, while no significant genetic variation was attributed to sampling the same bays across years. This provides strong evidence for temporal stability, especially when combined with prior evidence for stability of these populations across the five years between sample collections for the studies of Wirgin et al. (2007) and Kovach et al. (2010), together providing compelling evidence for long-term stability in the winter and spring spawning populations.

Given this demonstrated temporal stability, the study described in Kerr et al. (2018) combined the genotypes for the 2006-2008 and 2014-2015 samples to generate a full microsatellite dataset of 434 individuals. This served as a reference dataset for a mixed stock analysis of the fishery. The dataset had reasonably high resolution for discriminating among populations, with an  $F_{ST}$  of 0.0135 for winter and spring spawners overall. Assignment scores from DAPC were 78% and 74% for individual fish to the winter and spring populations, respectively. Power analyses of the mixed stock assignments (which estimated the overall proportion of fish from different spawning groups in a mixed sample) indicated considerably higher power, but depended on the proportional composition of the mixed groups.

For the modern commercial fishery, mixed stock samples were available from 131 individuals sampled during nine separate collections, from western GoM statistical areas 513 and 514 in 6 different months (March, May, June, July, December and January). These mixed stock samples were collected as representative of the modern fishery in the wGoM region. These samples were assigned to one of the two reporting groups – winter and spring – using a conditional likelihood approach. The full collection (all 131 samples) were slightly biased toward the winter spawners (60:40; Fig. 5). When analysed by season, the winter mixture was comprised of 77% winter spawners and the summer mixture was comprised of 80% spring spawners, while the spring mixture (March, April, May) was comprised of a mixture of both winter and spring spawners (Fig. 5). This finding makes sense if spring and winter spawning populations have only temporary residence in the western GoM and subsequently undertake migrations either up and down the coast or offshore (see tagging chapter). It also highlights that the period between March and May is when the fishery is the most mixed as it is comprised of both seasonal spawning components.



**Fig. 5.** Proportional assignments to spring and winter spawning populations from mixed stock analyses of commercial fishery mixtures a) overall, b) by season, and c) by month. Samples were collected, as representative of the modern western GoM fishery, by a fisherman conducting simulated fishing trips in statistical areas 513 (southern portion) and 514 of the western GoM.

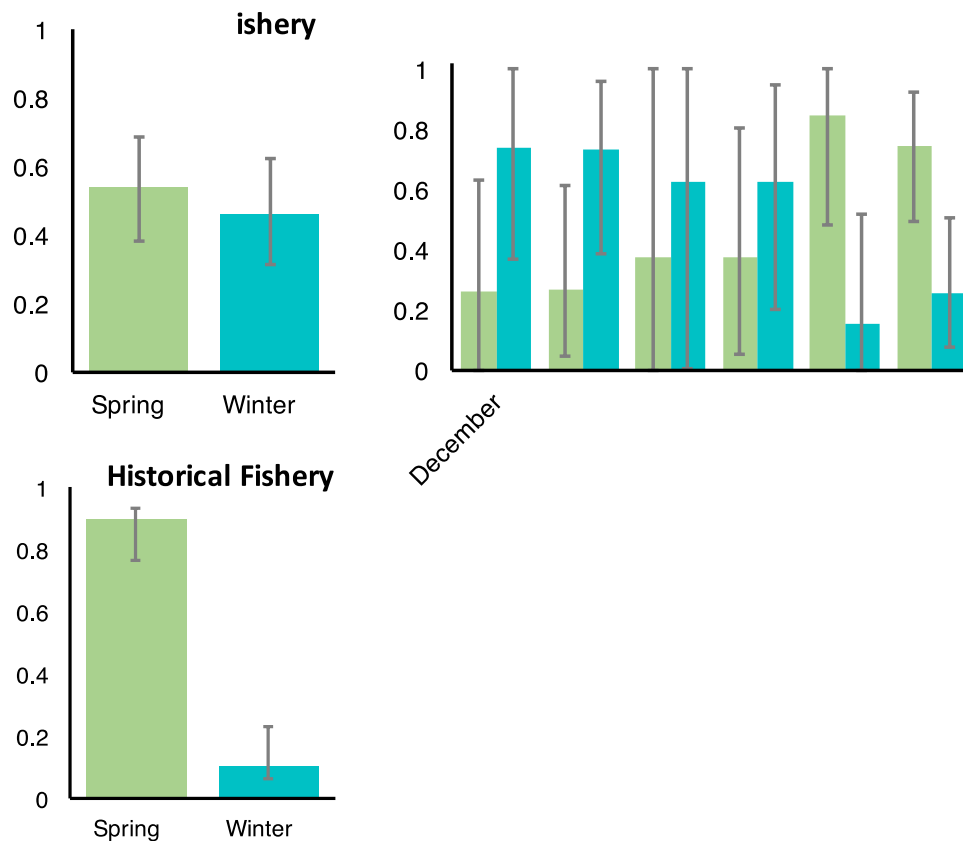
These mixed stock analyses demonstrate the utility of genetic markers for differentiating individuals of an unknown mixed grouping and provide insight into the seasonal differences in the western GoM fishery. The work to date is limited in its spatial scope and exclusive focus on the western inshore GoM, as well as by the use of only two reporting groups – winter and spring spawning western GoM spawners. These limitations stem from the limits of the resolution of the microsatellite data. Future work with mixed stocks fishery assignments should leverage the recent genomic studies and seek to use high resolution SNPs in an effort to assign fish of unknown origin to the five groupings identified in the work described in section 3.3.2 above. The much greater degree of differentiation among groups within SNP outlier regions along with preliminary, unpublished work with a subset of SNPs from Clucas et al. (2019a) suggest that finer discriminatory power is possible to the population or bay level (Kerr et al. 2018). To achieve these goals, development of a high-resolution SNP panel array would be useful and, with the appropriate logistical and financial support, could potentially lead to relatively efficient identification of fish to population origin, in a similar manner as is used to manage the Pacific salmon fishery.

### *Temporal Comparisons*

DNA analysis of historical samples can yield insight about population structure in the past and how it compares to that of contemporary times. From a fisheries perspective, these samples can come from archived otoliths or scales collected in systematic assessment surveys or from the commercial fishery (Nielsen and Hansen 2008). This type of historical DNA analysis can allow for reconstructing past population structure and identifying potential changes in genetic diversity or variation over time. This approach holds promise in US waters for 1) filling in gaps in our knowledge of the eastern GoM that exist due to the collapse of this fishery; and 2) testing hypotheses about prior population diversity (e.g. Ames 2004). If population components have been lost over time, this should be uncovered in genotypes obtained from historical analyses.

One study to date has addressed the question of changes in population structure in US waters over time. This unpublished study is reported in Kerr et al. (2018) and builds on the mixed stock analysis study reported in section 3.3.3. Archived otoliths were obtained from the commercial fishery collection from the NEFSC archive. The spawning condition of these samples was unknown. Microsatellite genotypes were generated from 232 individuals in two time periods, 1979-1982 and 1989-1992, from statistical areas 513, 514, and 515 in the wGoM. These samples were compared with both the modern commercial fishery of 2014-2015 and the winter and spring spawning reference populations. All five collections of otolith samples were found to be genetically distinct from the four modern spawning populations, with  $F_{ST}$  values ranging 0.018 to 0.045, substantially larger than the genetic distances among the modern cod populations. While differentiated from both modern spawning groups, the historical samples were more divergent from the winter spawners than the spring spawners and also strongly divergent from most of the modern fishery sample collections, with the exception of the June and July collections. Mixed stock analysis of the historical fishery samples indicated strong majority assignments to the spring spawning population (75-95% for all statistical areas and time periods; Fig. 6). However, an important limitation of this analysis is that it can only assign individuals to one of the two

reporting groups and cannot account for unsampled populations. Therefore, the best interpretation of these findings is that the historical samples were more similar to today's spring spawning population than to today's winter spawning populations and the historical fishery had a different composition than that of the modern fishery (which is more heavily dominated by the winter-spawning population). While the  $F_{ST}$  results suggest that the historical fishery was comprised of populations with a different genetic signature from the modern winter and spring spawning populations in Ipswich and Massachusetts bays, the historical mixed stock analysis study was not designed to directly test this hypothesis.



**Fig. 6.** Comparison of proportional assignments to winter and spring spawning groups from mixed stock analysis of the modern commercial fishery (top panel) and the historical fishery (bottom panel) overall (left) and by month or season (right).

In further work reported in Kerr et al. (2018), genetic diversity, as measured by allelic richness (sample-size corrected number of microsatellite alleles per population), was found not to differ between historical and modern samples, with the exception of a slight reduction in the diversity of the modern spring-spawning population. This points toward change in allele frequencies, rather than decrease in genetic diversity, driving the genetic differences observed between historical and modern samples. Specifically, a shift in allelic composition away from spring-

spawning genotypes and toward the winter-spawning genotypes is indicated by comparison of the historical and modern fishery.

Further work with higher resolution markers and finer scale sampling, of fish in known spawning condition, is needed to more clearly evaluate the structure of cod populations in the past and whether genetically distinct population components have been lost. One shortcoming of the analysis of historical fishery samples is that reproductive status of these fish is unknown. This can be resolved by using samples from the Northeast Fishery Science Center survey archive. At the time of writing, an ongoing study out of Cornell University and the University of New Hampshire (N. Lou, N. Therkildsen, G. Clucas, A. Kovach) is focused on whole genome sequencing analysis of historical otolith samples collected in spawning condition with specific location data (statistical area). This study will compare the historical genomic signatures with those of modern populations.

## Synthesis

In this concluding section, we synthesize findings reviewed in this chapter into a consensus view of population genetic structure for cod in US and adjacent Canadian waters, describe the interpretations from neutral and adaptive genetic markers and the implications of the genetic structure for management, and outline the remaining knowledge gaps and priority areas for future research.

### *Consensus Model of Population Genetic Structure*

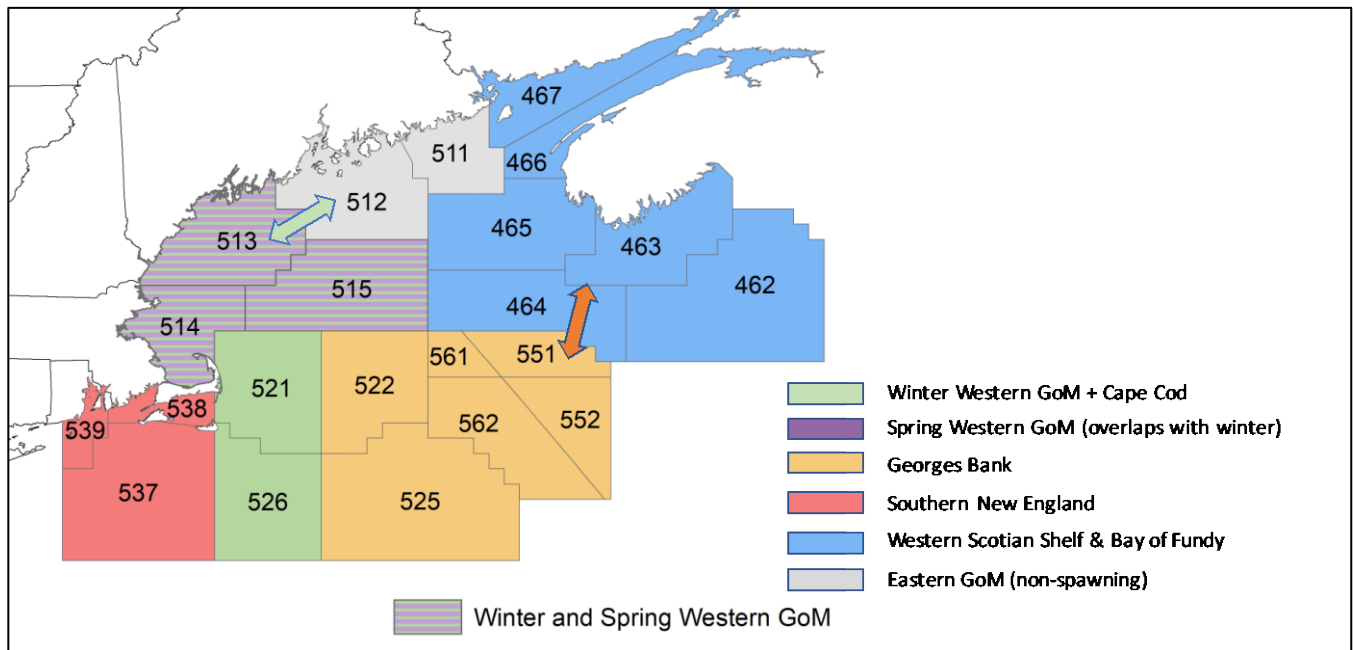
The following statements summarize key findings from review of existing genetic data, including adaptive and neutral genetic variation, in US and adjacent Canadian waters.

- Cod spawning in US and adjacent Canadian waters have a population genetic structure that is more complex than recognized by the current US 2-stock model or the 3-stock model for the international region (Gulf of Maine, Georges Bank, Western Scotian Shelf/Bay of Fundy), with heterogeneity within and connectivity between the currently defined stocks.
- Two genetically distinct groups – spring and winter spawning populations – comprise the western Gulf of Maine (wGoM).
- Spring spawners in the wGoM are genetically distinct from all other spawning populations in US and adjacent Canadian waters; in some genomic regions, wGoM spring spawners are more similar to Canadian populations of 4VsW and 3Ps than to US populations.
- Cod spawning in the Cape Cod, Nantucket Shoals and Great South Channel area are more genetically similar to winter spawning cod in the wGoM than they are to Georges Bank cod.
- Cod spawning in southern New England show genetic differentiation from Georges Bank, Cape Cod and Gulf of Maine cod.
- Cod spawning on Georges Bank from east of the Great South Channel (western Georges) to the Northeast Peak are genetically differentiated from cod spawning west of the Great South Channel in the Cape Cod area, southern New England and the GoM. There is some



variability among studies on the genetic group membership of cod spawning on western Georges Bank, and therefore the precise geographic location of the split between the Cape Cod /western GoM and Georges Bank is not yet resolved.

- The fit of eastern GoM (statistical areas 511 & 512) into the population structure model is not yet well resolved, due to the lack of spawning fish in this area. Analyses of non-spawning cod suggest there may currently be connectivity with western GoM and/or Georges Bank and that there may be inshore/offshore differences or differences between Penobscot and area 512. There may be a mixture of fish using this area during the non-spawning season.
- Cod spawning on Browns Bank share genetic similarities with those on eastern Georges Bank, suggesting exchange across the Northeast Channel.
- Cod populations in US and adjacent Canadian waters are differentiated from the Canadian populations found farther north on the eastern Scotian Shelf (4VsW) and St. Pierre Bank (3Ps).
- Synthesis of genetic data suggests the following groups, depicted in Figure 7:
  - 1) western GoM spring-spawning
  - 2) western GoM winter-spawning and Cape Cod area
  - 3) Georges Bank
  - 4) southern New England
  - 5) eastern Gulf of Maine
  - 6) Browns Bank, western Scotian Shelf and Bay of Fundy



**Figure 7. Model of cod population genetic structure in US and adjacent Canadian waters.** Six genetically differentiated spawning groups are denoted by statistical area, based on known spawning locations as follows: 1) spring spawning cod in the western GoM (purple); 2) winter-spawning cod in the western GoM winter plus Cape Cod, Nantucket Shoals and Great South

Channel; 3) cod spawning on western Georges Bank, east of the Great South Channel, and the Northeast Peak; 4) southern New England waters; 5) eastern GoM, which may be a distinct population, although the data from spawning cod are lacking to resolve this; 6) western Scotian Shelf and Bay of Fundy. The gray/green hatched area comprised by areas 513, 514 and 515 denotes the same spatial areas used separately by genetically distinct winter and spring spawning populations. Data from nonspawning cod in area 512 suggest connectivity with the western GoM winter spawning population (indicated by the green arrow). In addition, some level of connectivity exists between the western Scotian Shelf and Georges Bank via Browns Bank (indicated by orange arrow).

### *Inference from Neutral and Adaptive Variation and Chromosomal Inversions*

- Differences among cod populations are driven largely by regions of the genome under the influence of natural selection (i.e., adaptive genetic variation). This means that there are likely functional (ecological, life history, behavioral, or physiological) differences associated with the observed genetic variation.
- The majority of the observed genetic differences occur within 4 chromosomal inversions, which also have been associated with population structure in other parts of the cod range, including Canadian, Icelandic, and Norwegian waters. These chromosomal inversion regions have, across broad spatial scales, been associated with environmental variation in water temperature, salinity, depth, and oxygen, as well as with stationary/migratory ecotypes. Numerous genes associated with temperature-driven physiological processes have been identified in portions of these inversions. Although the exact functional role that these inversions play in differentiating US cod populations is not yet understood, the highly elevated levels of differentiation in these regions suggest ecologically relevant differences in adaptations of cod to these environmental drivers.
  - The inverted genomic regions differentiate US populations from more northern Canadian populations on the eastern Scotian Shelf (4VsW) and St. Pierre Bank (3Ps), although the western GoM spring spawners have genotypes intermediate those of the Canadian populations and the rest of US samples.
  - Similar linkage group genotypes between these northern Canadian cod and spring-spawning wGoM cod are also found in the Bay of Fundy and Browns Bank, suggesting cod in these areas may share similar adaptations to shared environmental or other drivers.
- In addition to the four chromosomal inversion regions, other portions of the genome exhibit differences among these populations. These “outlier” regions contain genes that function in reproduction (female hormone receptors) and thermal tolerance (heat shock proteins). These genes may be targets of natural selection that underlie adaptive differences among these populations.
- Neutral variation among populations is minimal. This suggests there may be some ongoing gene flow among populations or that they have not been differentiated long enough for neutral divergence to accumulate. Even very low levels of gene flow could

eliminate neutral differentiation between populations, while divergent selection can maintain large allele frequency differences even when levels of connectivity are relatively high. Adaptive differentiation in the face of gene flow is a phenomenon observed in other cod populations elsewhere in the range.

### *Implications of Cod Population Genetic Structure for Management*

While the interpretation of the extensive, genome-wide data summarized in this chapter is undoubtedly complex in the context of management, a few key take home messages readily emerge. First, while the genetic variation observed among populations in the GoM and surrounding waters is quite small as measured by the  $F_{ST}$  statistic, the observed structure is consistently detected across multiple, independent studies and marker types and is temporally stable, suggesting there are meaningful implications for population structure. Small but significant levels of genetic differentiation are common in marine fishes as a result of their high dispersal potential and large effective population sizes (Hauser and Carvalho 2008). There is now a great deal of evidence that even very small  $F_{ST}$  values among marine fish populations can coincide with migration rates that are sufficiently low to suggest demographic independence (Waples et al. 2008).

The observed genetic variation provides strong evidence for a greater complexity of population structure than currently recognized by the 2-stock model. The five population genetic groupings put forth in the synthesis model are consistent with aspects of prior hypothesized stock structures (e.g., Wise 1963) and with data from other disciplines, including tagging, natural markers, early life history stages, and what is known about oceanographic currents.

It is not uncommon, especially in marine systems, for populations that are only weakly differentiated at neutral markers to exhibit differentiation at adaptive loci as a result of divergent selection pressures. This adaptive divergence underlies differential ecological adaptation and suggests there may be unique ecological and functional diversity among populations (Crandall et al. 2000; Funk et al. 2012). Adaptive genetic variation is a component of biocomplexity, which – along with morphological, behavioral, physiological, and life history variation – may be highly relevant to fishery management (Hilborn et al. 2003; Ruzzante et al. 2006; Therkildsen et al. 2013). Maintaining adaptive variation, along with other forms of biocomplexity, could be key to ensuring adaptive capacity or evolutionary potential (Nicotra et al. 2015; Mable 2019). Biocomplexity may also confer resilience, and loss of intra-specific genetic diversity has been linked to reduced population stability and reduced resilience to exploitation and changing environmental conditions (Hilborn et al. 2003; Schindler et al. 2010; Kerr et al. 2010a,b). The latter may be particularly relevant to the Gulf of Maine, in light of its rapidly changing water temperatures and the finding of genetic polymorphisms that are linked to putative thermal tolerance and other temperature associated gene functions.

### *Remaining Knowledge Gaps and Future Research Needs*

A vast amount of new high-resolution genomic data has recently come to bear on the topic of cod population structure, confirming results of earlier genetic studies and providing new insights about the complexity of biological population structure. While these efforts reveal a clear consensus view, a few knowledge gaps remain. Firstly, the level of connectivity between western Georges Bank (i.e., the area east of the Great South Channel) and the Cape Cod area is yet not fully resolved. Further, the precise geographic location of the boundary between the Cape Cod/western GoM and Georges Bank populations is unclear (in the 68W or 69W area), due to small sample sizes on the east side of the Great South Channel in the studies to date. Resolving these uncertainties requires further research from samples of spawning cod in this region, obtained from multiple tows in additional years (i.e. beyond the ones reviewed in this chapter), with analyses to evaluate temporal variation. Additionally, knowledge gaps remain for the eastern GoM, from which samples from modern spawning cod are unavailable to provide a picture of current genetic structure. Given the lack of spawning cod in this region today, results of an ongoing historical analysis using archived otoliths from cod sampled in spawning condition by the NOAA NMFS trawling surveys in the 1980s and 1990s will be informative for reconstructing the genetic composition of this region in the past. To more clearly identify the origin of cod that occur in this region during the non-spawning season today, further studies using mixed stock analyses with large sample sizes of both juveniles and adults collected from the Sentinel Survey and the NMFS trawling survey are warranted.

The amount of mixing between the Bay of Fundy, Browns Bank and northeastern Georges Bank requires additional study as well, as the measures of genetic similarity between these two locations appears to vary from one year to the next (Puncher et al. in prep). This research should be combined with hydrodynamic data in order to elucidate the influence of annually changing water currents. Connectivity of these regions with the eastern GoM also warrants future study. Mixed stock analysis using juvenile samples collected in more locations in both US and adjacent Canadian water would enhance our understanding of the connectivity among the stocks.

Lastly, it may become necessary to develop tools to aid assessment of sympatric winter and spring spawning western GoM cod and possibly other populations that may occur in mixed stocks. To this end, development of a robust genetic screening assay, using highly informative SNP markers, both adaptive and neutral, would be beneficial.

## **Acknowledgments**

We thank Steve Cadrin for feedback on a prior draft of this chapter.

## **References**

Ames EP. 2004. Atlantic cod stock structure in the Gulf of Maine. *Fish Res.* 29(1):10–28.

Anderson EC, Waples RS, Kalinowski ST. 2008. An improved method for predicting the accuracy of genetic stock identification. *Can J Fish Aquatic Sci.* 65:1475-1486.

Arnason E, Hernandez UB, Krstinsson K. 2009. Intense habitat-specific fisheries-induced selection at the molecular Pan I locus predicts imminent collapse of a major cod fishery. PLoS One e5529.

Barney BT, Munkholm C, Walt DR, and Palumbi SR. 2017. Highly localized divergence within supergenes in Atlantic cod (*Gadus morhua*) within the Gulf of Maine. BMC Genomics 18(1): 1-14.

Barth JMI, Berg PR, Jonsson PR, Bonanomi S, Corell H, Hemmer-Hansen J, Jakobsen KS, Johannesson K, Jorked PE, Knutsen H, Moksnes, P-O, Star B, Stenseth, NC, Svedang H, Jentoft S, André, C. 2017. Genome architecture enables local adaptation of Atlantic cod despite high connectivity. Mol Ecol. 26(17): 4452–4466.

Berg PR, Jentoft S, Star B, Ring KH, Knutsen H, Lien S, Jakobsen KS, André C. 2015. Adaptation to low salinity promotes genomic divergence in Atlantic Cod (*Gadus morhua* L.). Genome Biol Evol. 7(6):1644–1663.

Berg, PR, Star B, Pampoulie C, Sodeland M, Barth JM, Knutsen H, Jakobsen KS, Jentoft S. 2016. Three chromosomal rearrangements promote genomic divergence between migratory and stationary ecotypes of Atlantic cod. Scientific Reports 6:23246.

Berg, PR, Star B, Pampoulie C, Bradbury IR, Bentzen P, Hutchings JA, Jentoft S, Jakobsen KS. 2017. Trans-oceanic genomic divergence of Atlantic cod ecotypes is associated with large inversions. Heredity 119:418–428.

Bradbury IR, Bowman S, Borza T, Snelgrove PVR, Hutchings JA, Berg PR, ... Bentzen P. 2014. Long distance linkage disequilibrium and limited hybridization suggest cryptic speciation in Atlantic cod. PLoS ONE, 9(9), e106380.

Bradbury IR, Hubert S, Higgins B, Bowman S, Borza T, Paterson IG, ... & Hutchings JA. 2013. Genomic islands of divergence and their consequences for the resolution of spatial structure in an exploited marine fish. Evol Appl. 6(3):450-461.

Bradbury IR, Hubert S, Higgins B, Borza T, Bowman S, Paterson IG, ... Bentzen P. 2010. Parallel adaptive evolution of Atlantic cod on both sides of the Atlantic Ocean in response to temperature. Proc. R. Soc. B. 277(1701): 3725–3734.

Burnett J, O'Brien L, Mayo RK, Darde JA, Bohan M. 1989. Finfish maturity sampling and classification schemes used during Northeast Fisheries Center bottom trawl surveys, 1963–89. NOAA Tech Memo NMFS-F/NEC-76. 1989; 76:14.

Cadrin SX, Friedland KD, Waldman J. 2005. Stock Identification Methods: applications In Fishery science, Elsevier Academic Press

Clucas GV, Kerr LA, Cadrin SX, Zemeckis DR, Sherwood GD, Goethel D, Whitener Z, Kovach, AI. 2019. Adaptive genetic variation underlies biocomplexity of Atlantic cod in the Gulf of

Maine and on Georges Bank. PLoS ONE, 14(5), e0216992.

Clucas GV, Lou RN, Therkildsen NO, Kovach AI. 2019. Novel signals of adaptive genetic variation in northwestern Atlantic cod revealed by whole-genome sequencing. *Evol. Appl.* DOI: 10.1111/eva.12861

Conover DO, Clarke LM, Munch SB, Wagner GN. 2006. Spatial and temporal scales of adaptive divergence in marine fishes and the implications for conservation. *J Fish Biol.* 69 (Supplement C):21-47.

Crandall KA, Bininda-Emonds ORP, Mace GM, Wayne RK. 2000. Considering evolutionary processes in conservation biology. *Trends Ecol. Evol.* 15:290–295.

Davey JW, Hohenlohe PA, Etter PD, Boone JQ, Catchen JM, Blaxter ML. 2011. Genome-wide genetic marker discovery and genotyping using next-generation sequencing. *Nat. Rev. Gen.* 12(7):499.

DeWoody JA, Avise JC. 2000. Microsatellite variation in marine, freshwater and anadromous fishes compared with other animals. *J Fish Biol.* Wiley/Blackwell 56:461–473.

Funk WC, McKay JK, Hohenlohe PA, Allendorf FW. 2012. Harnessing genomics for delineating conservation units. *Trends Ecol. Evol.* 27:489-496

Hansen MM, Kenchington E, Nielsen EE. 2001. Assigning individual fish to populations using microsatellite DNA markers. *Fish Fish.* 2:93–112

Henry AM. 2013. Assessing social resilience of Maine fishing communities and developing a longline groundfish survey. *Electronic Theses and Dissertations* (p. 130). University of Maine.

Hilborn R, Quinn TP, Schindler DE, Rogers DE. Biocomplexity and fisheries sustainability. *Proc Natl Acad Sci.* 2003; 100: 6564–6568. <https://doi.org/10.1073/pnas.1037274100> PMID: 12743372

Hodgkinson A, Eyre-Walker A. 2011. Variation in the mutation rate across mammalian genomes. *Nat. Rev. Gen.* 12(11):756.

ICES (2009) Report of the working group on the application of genetics in fisheries and mariculture (WGAGFM). ICES CM 2009/MCC:03, Copenhagen.

Jombart T, Devillard S, Balloux F. 2010. Discriminant analysis of principal components: A new method for the analysis of genetically structured populations. *BMC Genetics* 11:94.

Jonsdottir IG, Marteinsdottir G, Pampoulie C. 2008. Relation of growth and condition with the Pan I locus in Atlantic cod (*Gadus morhua* L.) around Iceland. *Mar. Biol.* 154:867-874.

Kerr LS, Cadrin SX, Goethel D, Kovach AI, Sherwood G, Whitener Z, Zemeckis D. 2018. Ecological Diversity of Atlantic cod in the Gulf of Maine and its Role in the Resilience of a

Fishery. Final Report to the National Oceanic and Atmospheric Administration for Saltonstall-Kennedy Grant # NA14NMF4270014.

Kerr LA, Cadrin SX, Secor DH. 2010a. Simulation modelling as a tool for examining the consequences of spatial structure and connectivity on local and regional population dynamics. *ICES J Mar Sci.* 67(8):1631–1639.

Kerr LA, Cadrin SX, Secor DH. 2010b. The role of spatial dynamics in the stability, resilience, and productivity of an estuarine fish population. *Ecol. Appl.* 20(2):497–507.

Kimura M. 1983. *The Neutral Theory of Molecular Evolution*. Cambridge University Press Cambridge, UK.

Kirk H, Freeland JR. 2011. Applications and implications of neutral versus non-neutral markers in molecular ecology. *Int J Mol Sci.* 12(6):3966–3988.

Kirubakaran TG, Grove H, Kent MP, Sandve SR, Baranski M, Nome T, ... Andersen Ø. 2016. Two adjacent inversions maintain genomic differentiation between migratory and stationary ecotypes of Atlantic cod. *Mol. Ecol.* 25(10):2130–2143.

Kovach AI, Breton TS, Berlinsky DL, Maceda L, Wirgin I. 2010. Fine-scale spatial and temporal genetic structure of Atlantic cod off the Atlantic coast of the USA. *Mar Ecol Prog Ser.* 410:177–195.

Lage C, Kuhn K, Kornfield I. 2004. Genetic differentiation among Atlantic cod (*Gadus morhua*) from Browns Bank, Georges Bank, and Nantucket Shoals. *Fish Bull.* 102:289–298.

Lepais O, Chancerel E, Boury C, Salin F, Manicki A, Taillebois L, et al. 2019. Fast sequence-based microsatellite genotyping development workflow for any non-model species. *bioRxiv*, 649772. <http://doi.org/10.1101/649772>

Mable BK. 2019. Conservation of adaptive potential and functional diversity: integrating old and new approaches. *Conserv. Gen.* 20: 89–100.

Manel S, Gaggiotti OE, Waples RS. 2005. Assignment methods: matching biological methods with appropriate techniques. *Trends Ecol. Evol.* 20:136–142.

Mariani S, Bekkevold D. 2014 *The Nuclear Genome: Neutral and Adaptive Markers in Fisheries Science*. In: Cadrin SX, Kerr L, Marian S (eds), *Stock identification methods*, 2<sup>nd</sup> edition. Elsevier Academic Press, San Diego, CA

Moen T, Hayes B, Nilsen F, Delghandi M, Fjalestad KT, Fevolden SE, ... Lien S. 2008. Identification and characterisation of novel SNP markers in Atlantic cod: evidence for directional selection. *BMC Genetics* 9(1):18.

Morrison CM. 1990. Histology of the Atlantic cod. *Gadus morhua*: an atlas. Part 3. Reproductive tract. *Can. Spec. Publ. Aquat. Sci.* No. 110.

- Nazareno AG, Bemmels JB, Dick CW, Lohmann LG. 2017. Minimum sample sizes for population genomics: an empirical study from an Amazonian plant species. *Mol. Ecol. Res.* 17:1136-1147.
- Nicotra AB, Beever EA, Robertson AL, Hofmann GE, O'Leary J. Assessing the components of adaptive capacity to improve conservation and management efforts under global change. *Conserv Biol.* 2015; 29: 1268–1278. <https://doi.org/10.1111/cobi.12522> PMID: 25926277
- Nielsen EE, Cariani A, Aoidh E, Maes GE, Milano I, Ogden R, Taylor M, et al. 2012. Gene associated markers provide tools for tackling illegal fishing and false eco-certification. *Nature Communications* 3:851
- Nielsen EE, Hansen MM. 2008. Waking the dead: the value of population genetic analyses of historical samples. *Fish Fish.* 9:450-461.
- Pella JJ, and Milner GB. 1987. Use of genetic marks in stock composition analysis. Pages 274–276 in N. Ryman and F. Utter, editors. *Population genetics and fisheries management*. University of Washington Press, Seattle.
- Puncher GN, Rowe S, Rose GA, Leblanc NM, Parent GJ, Wang Y, Pavey SA. 2019. Chromosomal inversions in the Atlantic cod genome: Implications for management of Canada's Northern cod stock. *Fish. Res.* 216:29-40.
- Pritchard JK, Stephens M, Donnelly P. 2000. Inference of population structure using multilocus genotype data. *Genetics.* 155:945–959.
- Rodrigue M. 2017. Developing a collaborative research program to evaluate fine-scale groundfish dynamics in eastern Maine. *Electronic Theses and Dissertations*. University of Maine. Retrieved from <https://digit.alcommons.library.umaine.edu/etd/2810>
- Ruzzante DE. 1998. A comparison of several measures of genetic distance and population structure with microsatellite data: bias and sampling variance. *Can. J. Fish. Aquat. Sci.* 55(1):1-14. <https://doi.org/10.1139/f97-203>
- Ruzzante DE, Taggart CT, Cook D. 1998. A nuclear DNA basis for shelf- and bank-scale population structure in northwest Atlantic cod (*Gadus morhua*): Labrador to Georges Bank. *Mol Ecol.* 7:1663–1680.
- Ruzzante DE, Mariani S, Bekkevold D, Andre´ C, Mosegaard H, Clausen LAW, et al. Biocomplexity in a highly migratory pelagic marine fish, Atlantic herring. *Proc R Soc B Biol Sci.* 2006; 273: 1459–1464. <https://doi.org/10.1098/rspb.2005.3463> PMID: 16777738
- Schindler DE, Hilborn R, Chasco B, Boatright CP, Quinn TP, Rogers LA, Webster MS (2010) Population diversity and the portfolio effect in an exploited species. *Nature* 465: 609-613



- Seeb, J. E., Carvalho, G., Hauser, L., Naish, K., Roberts, S., & Seeb, L. W. (2011). Single-nucleotide polymorphism (SNP) discovery and applications of SNP genotyping in nonmodel organisms. *Mol. Ecol. Res.* 11:1-8.
- Slatkin M. 1987. Gene flow and the geographic structure of natural populations. *Science* 236: 787–792.
- Sodeland M, Jorde PE, Lien S, Jentoft S, Berg PR, Grove H, ... Knutsen H. 2016. “Islands of Divergence” in the Atlantic cod genome represent polymorphic chromosomal rearrangements. *Genome Biol. Evol.* 8(4):1012–1022.
- Tautz D. 1989. Hypervariability of simple sequences as a general source for polymorphic DNA markers. *Nucleic Acids Res.* 17:6463–6471.
- Therkildsen NO, Hemmer-Hansen J, Hedeholm RB, Wisz MS, Pampoulie C, Meldrup D, et al. Spatiotemporal SNP analysis reveals pronounced biocomplexity at the northern range margin of Atlantic cod *Gadus morhua*. *Evol Appl.* 2013; 6: 690–705. <https://doi.org/10.1111/eva.12055> PMID: 23789034
- Waples RS. 1991. Pacific salmon, *Oncorhynchus spp.*, and the definition of “species” under the endangered species act. *Marine Fish. Rev.* 53:11–22.
- Waples RS. 1998. Separating the wheat from the chaff: patterns of genetic differentiation in high gene flow species. *J. Hered.* 89:438–450
- Waples RS, Gaggiotti O. 2006. What is a population? An empirical evaluation of some genetic methods for identifying the number of gene pools and their degree of connectivity. *Mol Ecol.* 2006; 15: 1419–1439. <https://doi.org/10.1111/j.1365-294X.2006.02890.x> PMID: 16629801
- Waples RS, Punt AE, Cope JM. 2008. Integrating genetic data into management of marine resources: how can we do it better? *Fish Fish.* 9:423–449
- Ward RD, Woodwark M, Skibinski DOF. 1994. A comparison of genetic diversity levels in marine, freshwater, and anadromous fishes. *J Fish Biol.* 44: 213–232. <https://doi.org/10.1111/j.1095-8649.1994.tb01200.x>
- Weiss E, Sanderson M, Gerlach G. 2005. Population structure and essential fish habitat mapping of western Georges Bank cod. Final Rep Coop Res Partners’ Program, Northeast Reg Off Natl Mar Fish Serv.
- Wise JP. 1963. Cod groups in the New England area. *Fish Bull.* 63(1):189–203.
- Willing E-M, Dreyer C, van Oosterhout C. 2012. Estimates of genetic differentiation measured by  $F_{ST}$  do not necessarily require large sample sizes when using many SNP markers. *PLoS One* e42649.

Wright S. 1931. Evolution in Mendelian populations. *Genetics* 16:97– 159.

Zemeckis DR, Martins D, Kerr LA, Cadrin SX. 2014. Stock identification of Atlantic cod (*Gadus morhua*) in US waters: an interdisciplinary approach. *ICES J Mar Sci.* 71:1490–1506.

Zhan L, Paterson IG, Fraser BA, Watson B, Bradbury IR, Ravindran PN, et al. 2017. megasat: automated inference of microsatellite genotypes from sequence data. *Mol. Ecol. Res.* 17(2):247–256. <http://doi.org/10.1111/1755-0998.12561>

# LIFE HISTORY

McBride, Richard S., Douglas R. Zemeckis, Gregory R. DeCelles, Ted Ames, Irene Andrushchenko, Lisa Kerr, Alicia S. Miller, and Steve Cadrin

## Abstract

Life history data are often used for defining stock structure because they are among the first data types generated from monitoring fisheries and are relevant to productivity and resiliency of fishery resources. Here we examined 3 life history traits of Atlantic cod, *Gadus morhua*: abundance and distribution, size at age 2, and age and length at maturity. Analyses include spatially-explicit data from the US Carolinas to the Canadian maritimes, including the Gulf of Maine and Georges Bank management units of cod. During a 48-year period, 1970-2017, abundance declined and the distribution of cod contracted. In addition, cod exhibited a discontinuous distribution between eastern and western Georges Bank, most evident during recent periods of low abundance. The size at age 2 and the maturity of cod differed between the 2 management units, at least historically, with 4 notable deviations: (1) the growth difference between units eroded as Gulf of Maine fish have become larger, and Georges Bank fish smaller, at age 2, (2) both length and age at maturity declined early in the 48-year period, but coherent spatial clusters were identifiable throughout the time series, (3) both growth and maturity observations indicated mixing of fish between southern Gulf of Maine management unit and the Great South Channel portion of the Georges Bank management unit, and (4) there were persistent differences in growth and maturity between western and eastern portions of the Georges Bank unit. Further consideration of the temporal instability of size at age 2 and maturity is warranted to determine if these traits continue to be dynamic in association with efforts to rebuild regional cod stocks.

Yellow is used to signal to other chapter authors that we are citing them within the doc

## Introduction

Many marine species have multiple, fine-scale subpopulations, each with varying levels of productivity and exploitation rates, requiring management measures that address this biocomplexity (Altukhov 1981; Ricker 1981, Cadrin et al. 2014). This is the case for Atlantic cod (*Gadus morhua*) in US waters, which has been described as a metapopulation consisting of multiple subpopulations and many finer-scale spawning components (Smedbol and Stephenson 2001; Zemeckis et al. 2014). Scientific uncertainty related to cod stock structure has been identified as a key factor contributing to difficulties in managing the rebuilding of cod populations in US waters (Annala 2012; NEFSC 2017).

Life history traits, such as distribution, growth, and maturation, provide direct insights into the productivity and resilience of fish stocks. Because collecting life history information is already a part of fishery monitoring programs, these data are typically available to inform an interdisciplinary review of a species' stock structure (McBride 2014a). The current 2-unit management model for cod in US waters was based, at least in part, on standardized trawl survey results that depicted distribution and abundance and growth and maturity in relation to boundaries for management unit 5 (i.e., Gulf of Maine, Northwest Atlantic Fisheries Organization [NAFO]

unit 5Y; Georges Bank, 5Z) and adjacent units (New York Bight, 6A; Canadian waters of the Gulf of Maine, 4X) (see Cournane et al. [this TM] for description of areas). For example, in terms of distribution, Serchuk and Wood (1979) concluded that extensive mixing occurred between southern New England/Middle Atlantic and Georges Bank because the near absence of juvenile cod in survey tows from Block Island to Cape Hatteras suggested that the cod from that area were not self-sustaining. In terms of growth, Penttila and Gifford (1976) reported a significant difference in the mean lengths-at-age for young cod collected in 3 areas: the Gulf of Maine, Georges Bank, and off Cape Cod/southern New England. In terms of maturity, Livingston and Dery (1976) reported differences in age at maturity between Gulf of Maine, Georges Bank, and Browns Bank (NAFO unit 4X). Together with other information about traditional fishing areas, tagging studies, parasite infestation, and differences in spawning times, it was concluded that minimal exchange of cod occurred between the Gulf of Maine and Georges Bank, but extensive mixing occurred between Georges Bank and in the southern New England/Middle Atlantic region (Serchuk and Wood 1979; Serchuk and Wigley 1992; Zemeckis et al. 2014).

Subsequently, changes in Atlantic cod life history traits have been noted. The spatial distribution of cod offshore the northeast United States – from the middle Atlantic seaboard north through the Gulf of Maine and Canadian waters – has contracted since the 1960s (Begg et al. 1999; Zemeckis et al. 2014; NEFSC 2017). In the Gulf of Maine, the distribution of cod has become concentrated in its southwestern portions for several decades now (Ames, 2004; NEFSC, 2017), while on Georges Bank, an apparent division in distribution has emerged between the eastern and western portions of the Georges Bank management unit (Begg et al. 1999; Zemeckis et al. 2014).

Although spawning and genetic stock structure will be addressed in separate chapters (Dean et al., this TM, Kovach et al., this TM), these aspects help explain the spatial and temporal metapopulation structure of cod (Zemeckis et al. 2014). Historically, cod spawned along coastal Maine, but many of these spawning components were extirpated by the 1940s with very low cod abundance remaining (Ames 2004, NEFSC, 2017). The western Gulf of Maine consists of genetically-distinct winter- and spring-spawning subpopulations (Kovach et al. 2010) with peak spawning occurring in November-December and May-June, respectively (Berrien and Sibunka 1999). Both subpopulations spawn near the 50 m isobath primarily in Massachusetts and Ipswich Bays (Siceloff and Howell 2013; Dean et al. 2014; Zemeckis et al., *In Press*). The northeast peak of Georges Bank is considered the most productive and consistent offshore cod spawning site, where spawning occurs at 20-90 m depth and peaks seasonally during January-April (Colton and Temple, 1961; DeCelles *et al.*, 2017). Spawning also occurs in the western portion of the Georges Bank management unit in the areas around the Great South Channel, Cape Cod, and Nantucket Shoals at 20-55 m depth and peaks seasonally during November-December (Berrien and Sibunka, 1999; DeCelles *et al.*, 2017). Cod spawning also occurs in southern New England around Coxes Ledge with a peak in spawning from December to February (Berrien and Sibunka, 1999).

Investigations of growth have been examined using otolith-derived ages and from tag-recapture data. Using the former method, Begg et al. (1999) found a persistent pattern of slow growth for cod from Gulf of Maine, faster growth on western Georges Bank, and fastest growth on eastern Georges Bank, during the period 1970-1997. Using the latter method, Tallack (2009, 2011) reported similar results; tagged cod, recaptured from 2003 to 2008, had faster growth rates but smaller asymptotic size on Georges Bank, and slower growth but largest size in the Gulf of Maine.

Tallack (2009) also reported evidence that fish tagged near Cape Cod were smaller and younger and appear to disperse with age into the eastern portion of Georges Bank and the Gulf of Maine.

Investigations of maturity have also continued to show spatial structure, as well as temporal variability. For example, Begg et al. (1999) reported that cod from the Georges Bank management unit matured at younger ages and greater lengths than Gulf of Maine cod, and O'Brien (1999) reported that the age at maturity declined for both stocks from 1970 to 1998 (see also Hunt 1996; Barot et al. 2004; Miller et al. 2018). Investigations into maturity have left finer-scale variability relatively unexplored.

As we approached this re-evaluation of Atlantic cod stock structure, we noted 3 issues to address. First, Annala (2012) identified a need to update the available data, which we do here, up to 2017. Second, comparisons of model-based growth coefficients by Begg et al. (1999) and Tallack (2009, 2011) may be correlated with different maximum length estimates for different areas (i.e., the Brody coefficient,  $K$ , versus an asymptotic length,  $L_\infty$ ) and are simply difficult to fit based on small samples of large fish ( $L_\infty$ ). Third, a few studies report finer-scale analyses, such as comparing cod life history traits between eastern and western Georges Bank (Penttila and Gifford 1976; Begg et al. 1999; Tallack 2009), whereas others compare only between current management units without scrutiny of finer-scale geographic variation. Although these situations may arise from data limitations beyond the control of the investigators, we attempt to mitigate them in our re-evaluation of stock structure.

This study draws on a single, updated source of data – the NOAA Northeast Fisheries Science Center bottom trawl survey – to evaluate cod distribution and abundance, and growth and maturity across a latitudinal range from 35°N to 45°N between 1970 and 2017. Although other long-term surveys exist, (e.g., US state waters, Canada DFO federal waters), coverage varied both spatially and temporally, which precludes any straightforward pooling of these data sources. In analysis, we avoided model-based estimates of growth, instead using direct measures of size at age 2, as originally used by Penttila and Gifford (1976), and to examine fine-scale structure, we post-stratified growth and maturity data into statistical areas arranged hierarchically within the Georges Bank and Gulf of Maine management units. These findings update aspects of cod life history for comparison and integration with the findings from other stock identification tools used in this Technical Memorandum (e.g., tagging, genetics, natural markers), working towards an interdisciplinary review of cod stock structure in US waters.

## Methods & Materials

### *Life history sampling*

Atlantic cod were collected as part of a fishery-independent bottom trawl survey for groundfish operated by NOAA's Northeast Fisheries Science Center (hereafter referred to as 'the NOAA bottom trawl survey'). This survey operated across the geographic range of interest for defining cod stock boundaries: throughout Northwest Atlantic Fisheries Organization areas 5Z (southern New England and Georges Bank) and 5Y (Gulf of Maine), in parts of 4X (Bay of Fundy, Scotian Shelf), as well as further south (6A-C; Block Island Sound to Cape Hatteras), as described by [Cournane et al. \(this TM\)](#). Tows were assigned using a stratified, random sampling design within

inshore and offshore waters (Politis et al. 2014), and latitude and longitude positions reported here are from the beginning of the trawl tow.

Although this survey began in the 1960s (Reid et al. 1999), sampling for age and maturity began in 1970 (Penttila and Gifford 1976). Sampling stopped in 2 Canadian areas during this period: parts of the Scotian Shelf in 1979 and Browns Bank after 1987. As a result, while data from these specific statistical areas of Canada are included in initial geographic plots, they are not included in subsequent cluster analysis because comparisons across the entire period are not possible. We end sampling in all other areas with 2017, resulting in a 48-year time series. Sampling occurred twice each year: spring (approximately March-May) and fall (September-November). Specific dates and number of tows per season and year are tabulated in the supplemental materials (Table S1).

Catch data (number per tow and kg per tow) of cod were recorded for each tow. Individual fish lengths (fork length; 1 cm) were measured for at least a subsample from large tows (Reid et al. 1999). Age of individual cod, in years, was determined using otoliths, assigning an age based on the number of complete annuli and the edge type (Penttila and Dery 1988). Sex and maturity of individual cod were assigned by macroscopic examination of the dissected gonad following Burnett et al. (1989).

### *Data processing*

Although changes (both vessel and gear related; e.g., Azarovitz 1981) to the survey have taken place, no conversion calculations were performed on the raw data. In terms of the decommissioning of the Fishery Survey Vessel (FSV) Albatross IV in 2008 and transfer of operations to the FSV Henry Bigelow, calibration tows between these FSVs demonstrate that the latter catches more smaller, younger fish than the former (Brooks et al. 2010). Tows were not used if they failed quality control metrics (i.e. Station-Haul-Gear criteria > 136 or Type-Operational-Gear-Acquisition criteria > 132; Politis et al. 2014).

Data for the 48-year period were pooled into eight 6-year periods (i.e., 1970-1975, etc.) to balance sample size with temporal discreteness. This convention of the same 6-year periods was followed for growth and reproductive analyses.

Size at age 2 was used as a proxy for growth during the immature or early mature phase. A total of 14,042 age-2 cod were caught north of 35°N, with at least 3,200 individuals of either sex in each season, and only 80 without sex determined (Table 1). Median adjusted size at age 2 was about 8 cm larger in the fall than spring, so seasons were always kept separate.

Table 1. Adjusted spring and fall fork length (cm) quintile boundaries for age-2 Atlantic cod, *Gadus morhua*, males and females collected by the NOAA bottom trawl surveys, 1970-2017. Number of individuals = *n*.

| Season | Sex    | 0%   | 20%  | 40%  | 60%  | 80%  | 100% | <i>n</i> |
|--------|--------|------|------|------|------|------|------|----------|
| Spring | Male   | 16.5 | 31.5 | 36.5 | 40.3 | 44.4 | 64.0 | 3701     |
| Spring | Female | 13.8 | 30.8 | 35.4 | 39.8 | 44.6 | 59.7 | 3260     |

|      |        |      |      |      |      |      |      |      |
|------|--------|------|------|------|------|------|------|------|
| Fall | Male   | 22.7 | 38.3 | 43.2 | 47.4 | 52.4 | 69.2 | 3605 |
| Fall | Female | 23.7 | 38.8 | 43.2 | 47.6 | 52.7 | 72.0 | 3396 |

Directly observed sizes of age-2 fish could be biased by differences in survey timing, which can vary by weeks within a season and between regions and years. To adjust for this, the fish age was increased above 2.0 by the day of the year, and the resulting quotient of size and fractional age was multiplied by 2.25 for fish collected in spring and 2.75 for fish collected in fall, as an index of size at age 2 for April 1 and October 1, respectively. Additional bias in age resulting from different spawning seasons – spring versus fall (Dean et al., this TM) – and its effect on size at age could not be accounted for with the methods used here.

Hunt (1996) reported sexual dimorphism in Atlantic cod, but females did not become consistently larger than males until after age 3. Here, the mean difference in adjusted size at age 2 between sexes was small, ~0.5 cm in both seasons, but statistically significant ( $P_{\text{spring}} = 0.02$  vs.  $P_{\text{fall}} = 0.03$ ; Student's 2-sample t-test with the Welch approximation for heteroscedasticity of variance as indicated by Levene's test for spring). However, the direction of this difference was not consistent, as the spring mean of females was smaller than males (37.6 vs. 38.1 cm) but the fall mean of females was larger than males (45.6 vs. 45.2 cm). In terms of transparency, sexes were kept separate for initial spatial analysis (i.e. descriptive maps), but all 14,042 age-2 fish were pooled later to achieve adequate sample sizes for season-specific summary statistics and corresponding cluster analysis of size at age 2.

Finally, individual age-2 fish were assigned to growth quintiles – from the smallest sizes at age 2 to the largest sizes at age 2 – using all years of data, 1970-2017, but partitioned by sampling season and sex (Table 1). Quintiles were assigned color-based growth rates, purple being the slowest growing quintile to red being the fastest growing quintile (Fig. 1), to be used later for spatial analysis.

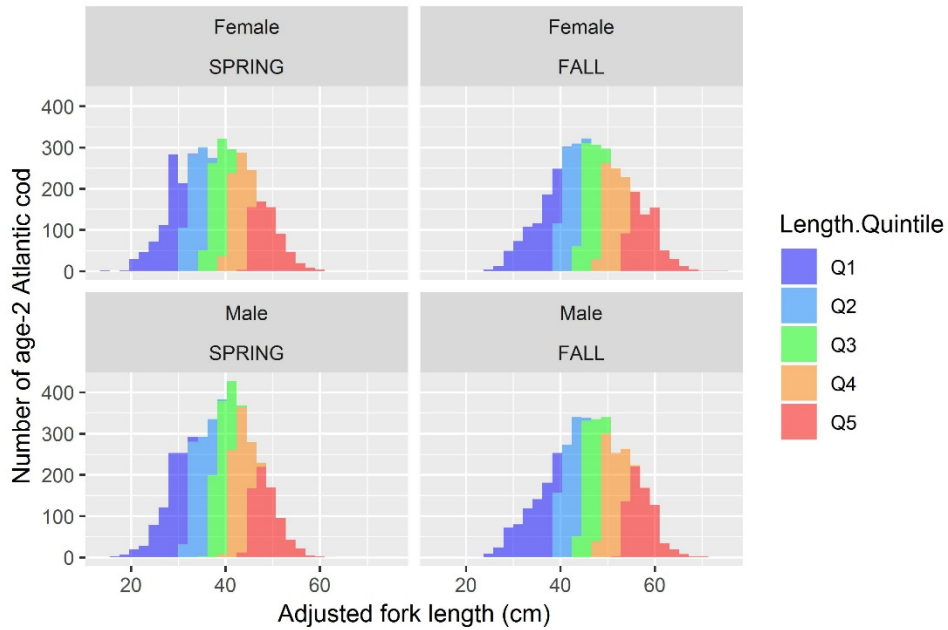


Figure 1. Partitioning of size along a quintile gradient: slowest (purple) to fastest (red) growing age-2 Atlantic cod, *Gadus morhua*, collected by the NOAA bottom trawl survey, 1970-2017. Fork length was adjusted for date of capture, as described in the text. See Table 1 for specific boundary values for each quintile.

Maturity data were examined for female cod collected by the spring NOAA bottom trawl survey. These totaled 14,710 individuals ranging from 5 to 150 cm fork length and from 0 to 17 years old (Table 2). Fish were assigned a maturity class by visually inspecting the gonad at sea (Table 2), but for these analyses, the data were collapsed into 2 classes (i.e., a binary response: either immature [1 immature class] or mature [the remaining classes]).

Table 2. Number of female Atlantic cod, *Gadus morhua*, collected in spring NOAA bottom trawl surveys, 1970-2017. Data are organized by fork length bins (left, 0 = 0-9 cm) or whole age (right, years) and maturity class (Immature [I], Developing [D], Ripe [R], Ripe & running [U], Spent [S], and Resting [T]).

| Length<br>(10<br>cm) | Maturity Class |     |    |   |    |      |
|----------------------|----------------|-----|----|---|----|------|
|                      | I              | D   | R  | U | S  | T    |
| 0                    | 2              | 0   | 0  | 0 | 0  | 0    |
| 1                    | 409            | 2   | 0  | 0 | 0  | 3    |
| 2                    | 1175           | 17  | 0  | 0 | 0  | 56   |
| 3                    | 1282           | 53  | 7  | 1 | 6  | 438  |
| 4                    | 1069           | 211 | 27 | 1 | 48 | 1360 |

| Age<br>(yr) | Maturity Class |     |    |   |     |      |
|-------------|----------------|-----|----|---|-----|------|
|             | I              | D   | R  | U | S   | T    |
| 0           | 2              | 0   | 0  | 0 | 0   | 0    |
| 1           | 1290           | 9   | 0  | 0 | 0   | 27   |
| 2           | 2006           | 161 | 13 | 0 | 34  | 1020 |
| 3           | 840            | 237 | 56 | 5 | 241 | 2403 |
| 4           | 287            | 305 | 92 | 7 | 269 | 1995 |



|    |     |     |    |    |     |      |
|----|-----|-----|----|----|-----|------|
| 5  | 429 | 259 | 58 | 3  | 180 | 1954 |
| 6  | 145 | 237 | 67 | 4  | 260 | 1638 |
| 7  | 20  | 185 | 70 | 4  | 222 | 1015 |
| 8  | 3   | 183 | 41 | 14 | 196 | 509  |
| 9  | 0   | 107 | 30 | 10 | 91  | 232  |
| 10 | 0   | 42  | 18 | 2  | 52  | 105  |
| 11 | 0   | 28  | 10 | 2  | 24  | 44   |
| 12 | 0   | 8   | 2  | 0  | 10  | 16   |
| 13 | 0   | 3   | 1  | 0  | 3   | 6    |
| 14 | 0   | 0   | 0  | 0  | 1   | 0    |

|    |    |     |    |   |     |      |
|----|----|-----|----|---|-----|------|
| 5  | 55 | 276 | 57 | 6 | 230 | 1020 |
| 6  | 14 | 137 | 48 | 7 | 129 | 466  |
| 7  | 5  | 87  | 33 | 4 | 76  | 208  |
| 8  | 1  | 40  | 10 | 7 | 49  | 88   |
| 9  | 1  | 33  | 8  | 1 | 29  | 35   |
| 10 | 0  | 11  | 7  | 3 | 13  | 28   |
| 11 | 0  | 14  | 3  | 1 | 7   | 9    |
| 12 | 0  | 6   | 1  | 0 | 6   | 6    |
| 13 | 0  | 1   | 0  | 0 | 2   | 3    |
| 14 | 0  | 3   | 2  | 0 | 3   | 3    |
| 15 | 0  | 1   | 0  | 0 | 0   | 4    |
| 16 | 0  | 1   | 0  | 0 | 2   | 0    |
| 17 | 0  | 0   | 0  | 0 | 0   | 1    |

No spatial segregation of immature or mature females in either season was identified. Therefore, these data were fitted to a generalized linear model using a logit link function, and the resulting coefficients were used to calculate the median length at maturity,  $L_{50}$ , and age at maturity,  $A_{50}$ , as well as the associated standard errors, using `dose.p` from R’s MASS package (R Development Core Team, 2014). All other data wrangling and statistical analyses were computed with R software, as well.

### *Spatial analysis*

Abundance, growth, and maturity were first plotted in a descriptive manner, mapping without consideration of past or current stock boundaries. Abundance data were plotted without regard to sex for both biomass per tow (Figs. 2-3) and number per tow (supplemental information). Initially, adjusted size-at-age-2 data were plotted at the individual fish level separately by seasons and sexes, and maturity parameters were estimated for females in spring aggregated at  $1^\circ \times 1^\circ$  latitude-longitude resolution.

For cluster analysis, data were aggregated by statistical areas, which are used for reporting fish landings (Halliday and Pinhorn 1990, Cournane et al.; this TM). These were assigned an “Area\_stock,” label, a combination of the numerical statistical area used for reporting landings and an abbreviated description of where this area is located and how it fits into the current management units for cod. For example, primary Canadian statistical reporting areas are in the 400s, US areas included in the current stock assessment areas are 500s and 600s. The descriptive abbreviations identify the Scotian Shelf (SS), Bay of Fundy (BF), Gulf of Maine (GOM), Georges Bank (GB), southern New England (SNE), and the New York Bight (NYB), with some areas subdivided as north (No.), south (So.), central (Ce.), west (W), and east (E). Some adjacent statistical areas were combined because of low sample sizes. A map of these statistical areas is depicted in Fig. 2 (see also Cournane et al., this TM).

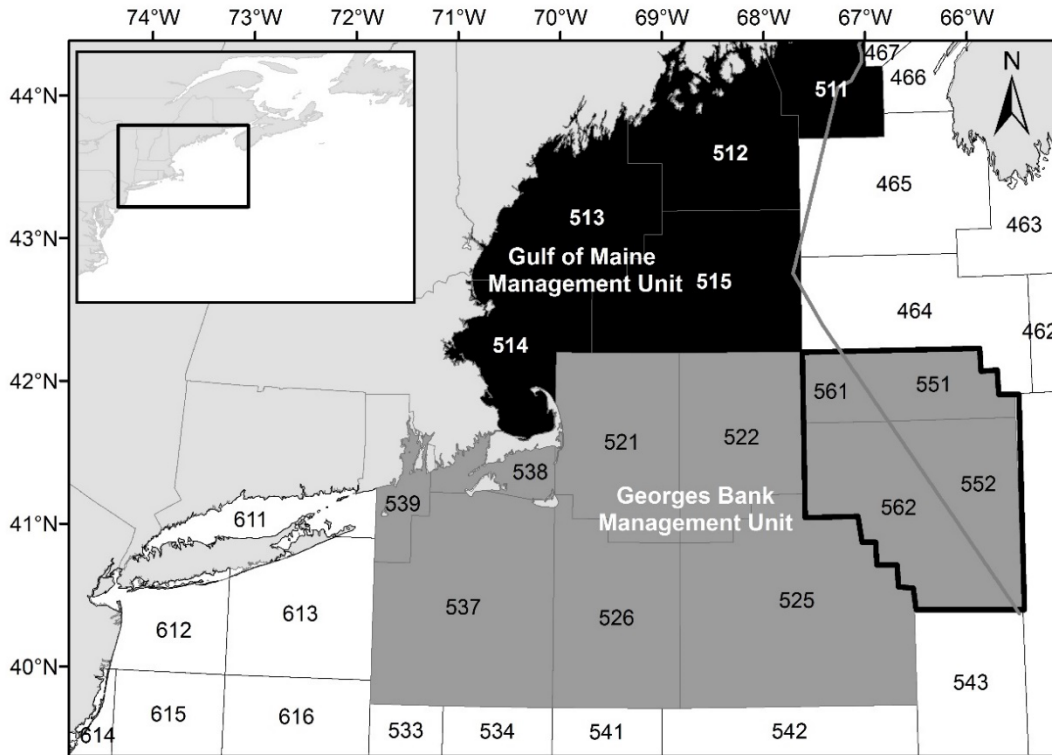


Figure 2. Current management units applied to Atlantic cod in US waters and the enumerated statistical areas. The eastern portion of George Bank (outlined in bold) is managed jointly between the United States and Canada as a transboundary resource, and the Hague line, delineating US from Canadian marine territory, is indicated as a grey chevron.

As background, these statistical areas form the basis of cod stock assessments, because they represent the fundamental unit for which much of the fisheries data are collected. Presently, cod are assessed and managed domestically as 2 stocks in the US using the following statistical areas: the Gulf of Maine (areas 511-515) and Georges Bank (areas 537-539, 521, 522, 525, 526, 551, 522, 561, 562) stocks. These 2 sets of the ‘500’ statistical areas are referred to later in the text as ‘management units,’ to reflect that they are the current, status quo depictions of stock structure in the US. Layered on these geographic units, a separate, bilateral assessment of eastern Georges Bank only (areas 551-2, 561-2) is completed annually by US and Canadian fisheries agencies through the Transboundary Resource Assessment Committee (TRAC), the outcomes of which are considered in the domestic management process of the full Georges Bank unit. In addition, catches of cod from NAFO area 6 (statistical areas in the 600s) are included in the assessment of the full Georges Bank management unit described above (e.g., NEFSC 2012).

Divisive cluster analysis (DIANA), using the "cluster" and "dendextend" packages in R, tested how well the growth and maturity data conform to the cod stock boundaries used in the US stock assessment and management process (e.g., Cope and Punt 2009). ‘Growth’ phenotypes, by statistical area and season, were clustered using the mean and standard deviation of the adjusted size at age 2. ‘Maturation’ phenotypes, by statistical area and considering both length and age at

maturity, were clustered using the median and standard error of the estimate. Clusters were performed for 2 periods: (1970-1975 and 2012-2017) to determine the stability of this phenotypic stock structure at the initial and most recent periods of the NOAA bottom trawl survey time series.

Sample size was also considered here but as a selection criteria and not as a cluster variable, because small sample sizes could lead to an inaccurate or imprecise estimate. For growth clustering, only statistical areas with 5 or more fish were used. For maturation clustering, only areas with a sample size > 30 were used.

## Results

### *Distribution and abundance*

Spring distribution of cod ranged broadly offshore of the DelMarVa peninsula and northward to Cape Cod, across Georges Bank, and well into Canadian waters of the Gulf of Maine, whereas in fall cod were rarely distributed west of 72°W or south of 40°N, and they were uncommon even on the southern flank of Georges Bank (Fig. 3). However, this southern part of the spring distribution has contracted over time, with few cod observed south or west of Block Island Sound (approximately 41.3°N, 71.7°W) since the 1990s. Although biomass is presented in the text, there were no qualitative differences in patterns based on numbers of cod per tow (Supplemental Material; Fig. S1).

On Georges Bank, the distribution of cod has contracted over the period 1970-2017 and is now concentrated on the northeast peak. West of the Bank, from Cape Cod and into the Great South Channel area, there is a concentration of cod that is more contiguous with the southern Gulf of Maine rather than Georges Bank. Both concentrations appear to have existed since the 1970s but are more obvious now that cod are less dense across the entire region in recent decades (Figs. 3-4).

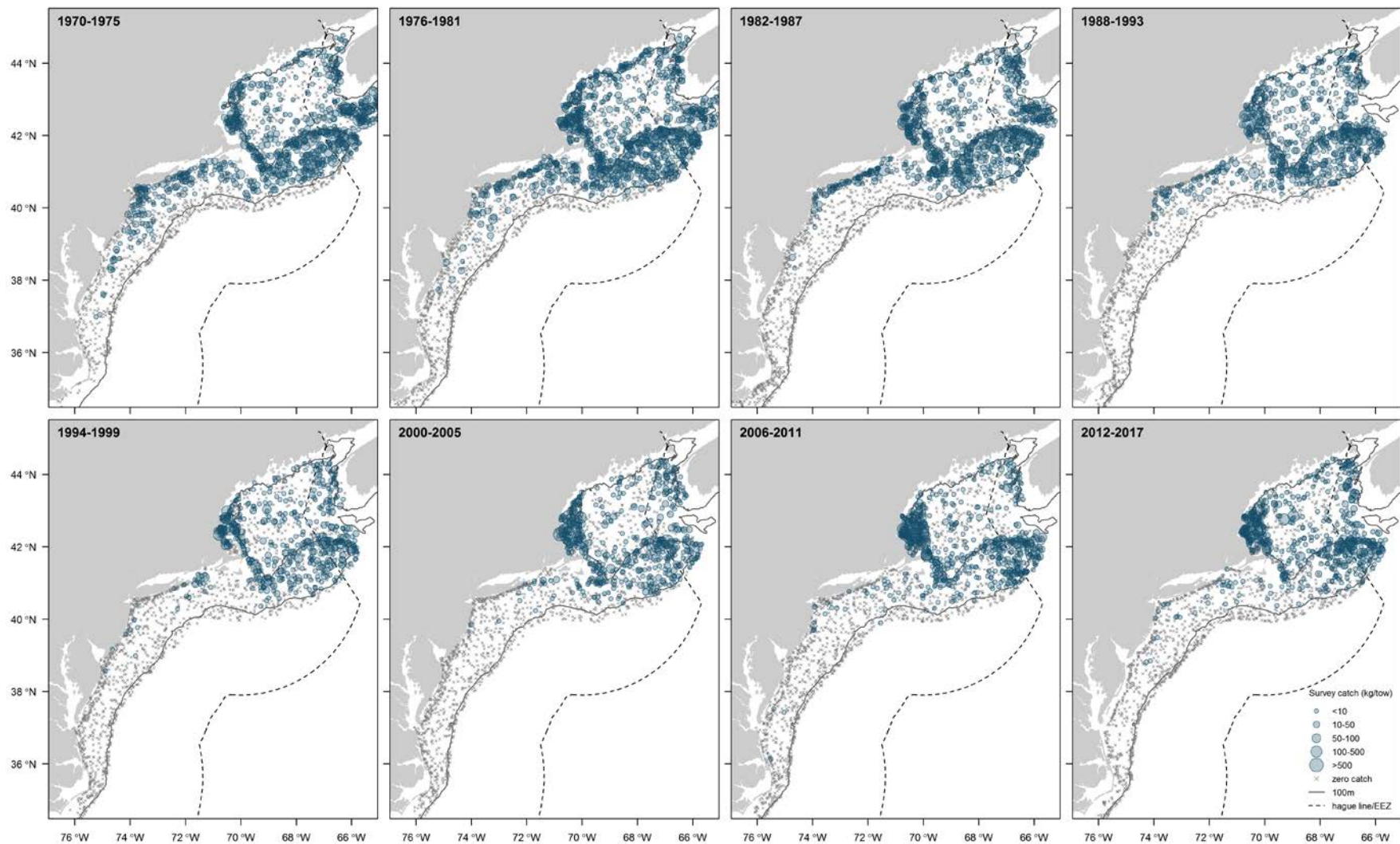


Figure 3A. Spring distribution and biomass (aggregate weight per tow) of Atlantic cod, *Gadus morhua*, during eight 6-year periods, 1970-2017, of the NOAA bottom trawl survey. See next page for fall data. The solid isobath = 100 m, and the dashed line delineates the 200 mile exclusive economic zone. Data for numbers per tow are depicted in Fig. S1.

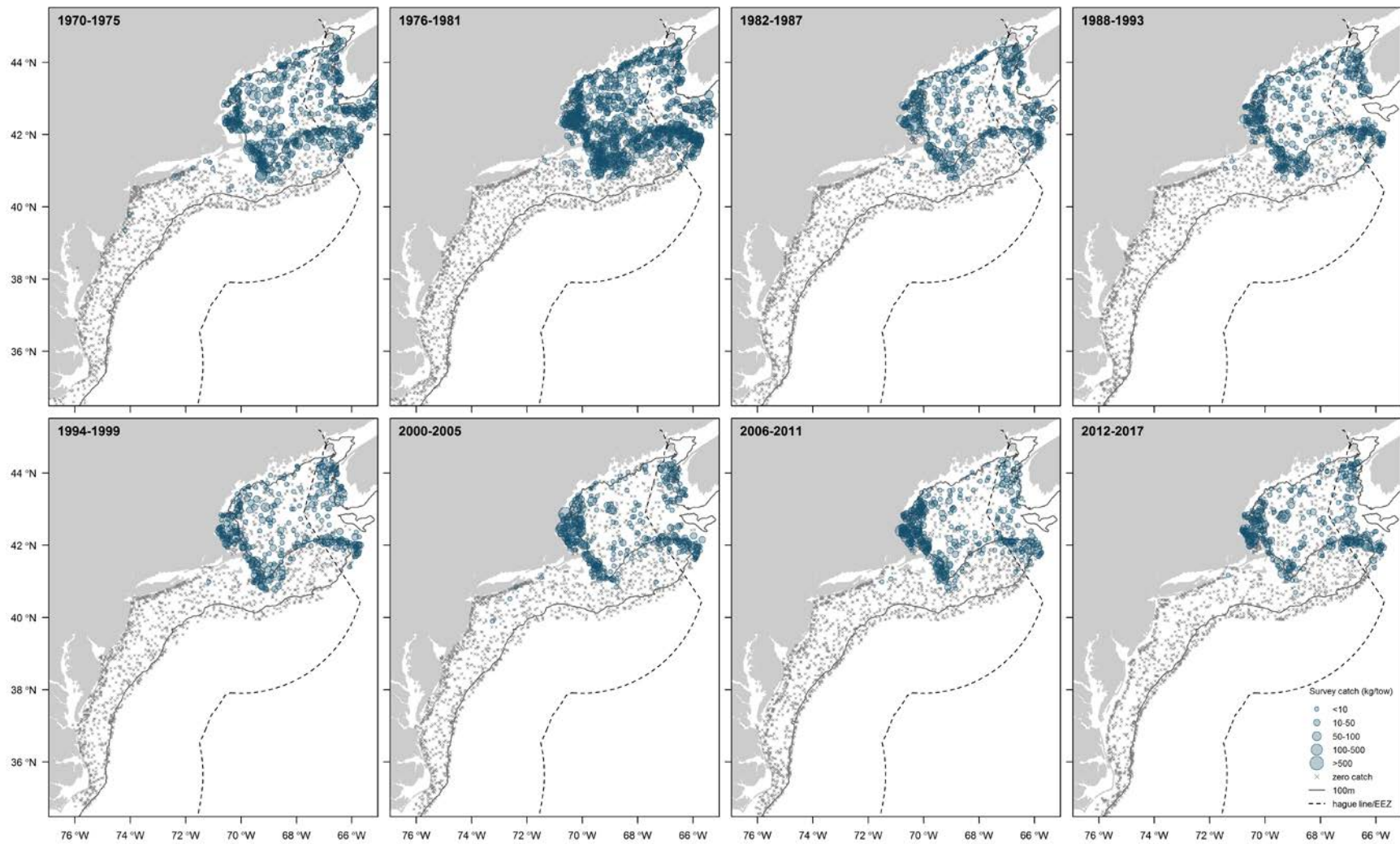


Figure 3B. Fall distribution and biomass (aggregate weight per tow) of Atlantic cod, *Gadus morhua*, during eight 6-year periods, 1970-2017, of the NOAA bottom trawl survey.



On the US side of the Gulf of Maine, abundance has consistently been highest in the southwest part and lower in the northern part, particularly offshore of downeast Maine, and the open, central part of the Gulf. In Canadian waters, cod have been consistently present on the Scotian Shelf and in the Bay of Fundy; however, the disappearance of fish on Browns Bank, evident in the last 5 panels, 1988-2017, is an artifact created when sampling was stopped there in the 1980s.

In summary, during the last 5 decades, 1970-2017, the cod population distribution has become more aggregated, and is now primarily concentrated into 2 areas: 1) the southwest part of the Gulf of Maine and extending into the Great South Channel, and 2) on the northeast peak of Georges Bank.

### *Size at age 2 – descriptive*

At a broad-scale, age-2 cod were distributed widely throughout the Gulf of Maine as well as across Georges Bank (Figs. 4-6). Offshore of southern New England and further west ( $> 72^{\circ}\text{W}$ ) and south ( $< 40^{\circ}\text{N}$ ), they occurred but less frequently: mostly in spring, less so in fall; mostly in the first 6-year period, 1970-1975, and less so in later periods (Supplemental Figs. S2, S3).

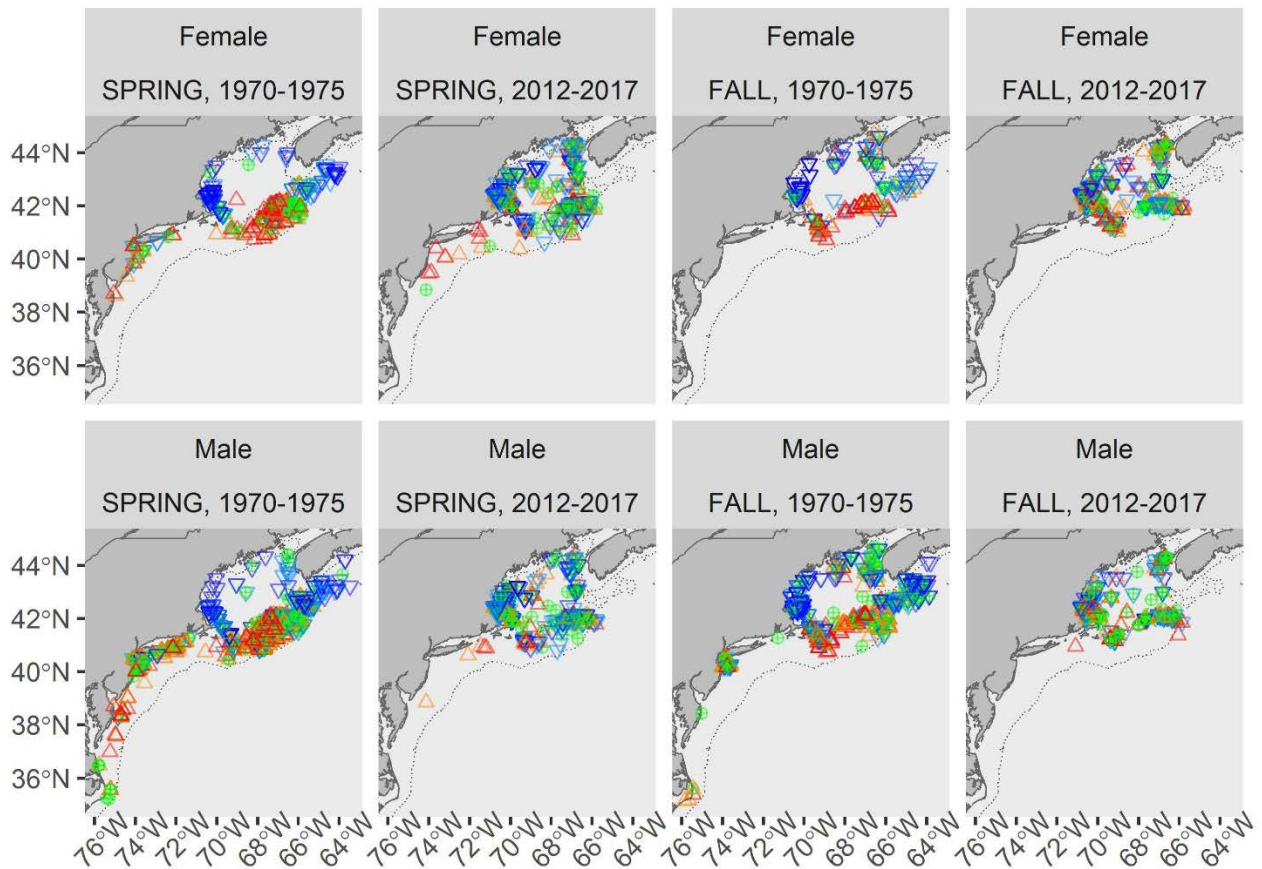
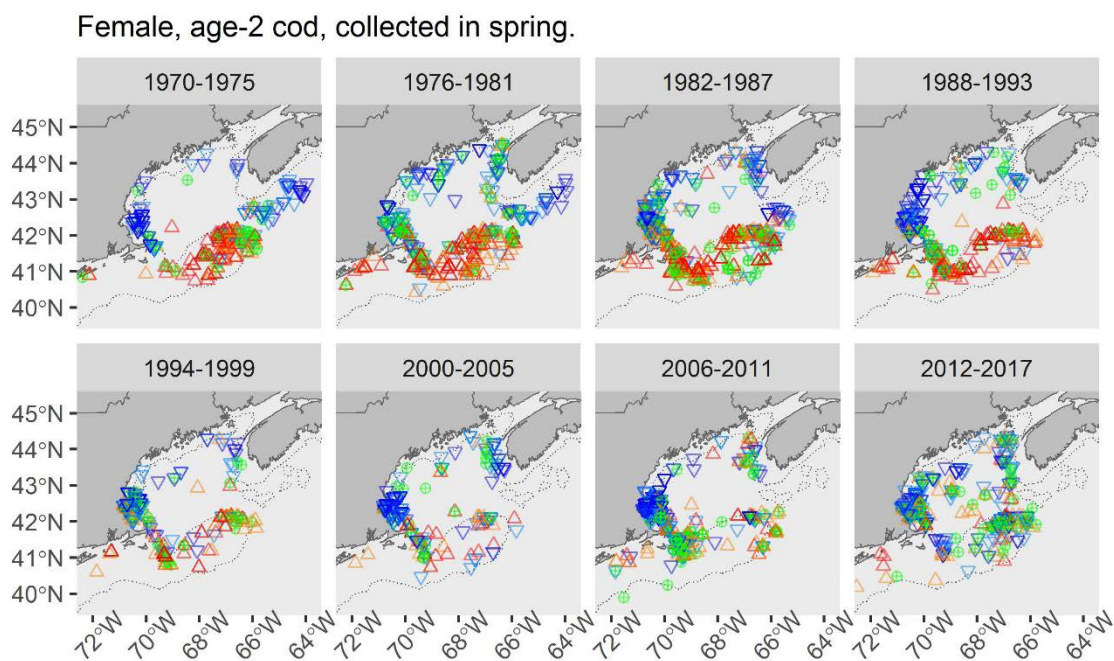


Figure 4. Geographic distribution of age-2 Atlantic cod, *Gadus morhua*, grouped by sex (Female, Male), season (SPRING, FALL), and the first and most recent of eight 6-year periods, 1970–2017, sampled by the NOAA bottom trawl survey. Color coding is translucent to reveal overlay of points, using a color spectrum from Figure 1 to indicate a size-at-age gradient. Smaller (purple-blue; quintile 1-2) fish are also marked with upside-down triangles, medium (green; quintile 3) fish with a crossed-circle, and larger (orange-red; quintile 4-5) fish with rightside-up triangles. The dotted isobath = 100 m. All 8 periods are depicted in the supplemental materials (Figs. S2, S3).

Age-2 cod were segregated by size along a general latitudinal gradient in the first 3 decades, approximately 1970–2000, but these spatial differences have diminished in recent years (Fig. 5 [spring data], Fig. 6 [fall data]). Early on, the above average sizes of cod (orange-red) were mostly on Georges Bank and distributed along the Middle Atlantic seaboard from Cape Cod to Cape Hatteras. The below average sizes of cod (purple-blue) were mostly distributed in the Gulf of Maine and on the Scotian Shelf and Browns Bank. Spatial segregation of larger and smaller age-2 fish, between these 2 regions broke down in the last 1–2 decades, sometime after 2000–2005, particularly stemming from the near absence of larger fish (red quintile) in any area. These patterns were evident for both males and females, plotted separately in Figures 5, 6.



Male, age-2 cod, collected in spring.

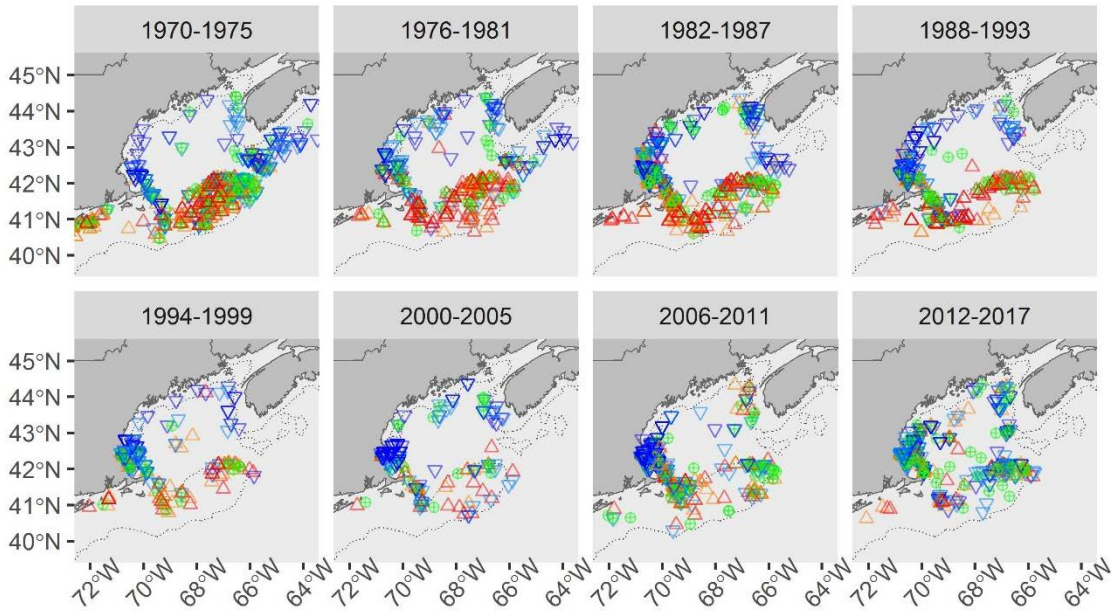
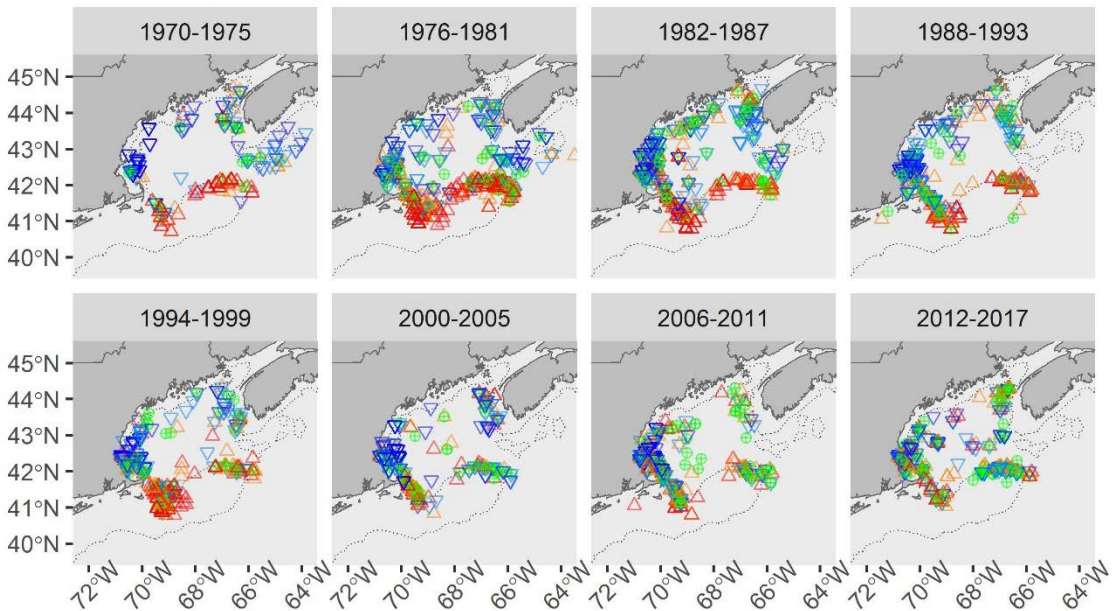


Figure 5. A closer look at the spring geographic distribution of female (top) and male (bottom) age-2 Atlantic cod, *Gadus morhua*, 1970-2017.

Female, age-2 cod, collected in fall.





Male, age-2 cod, collected in fall.

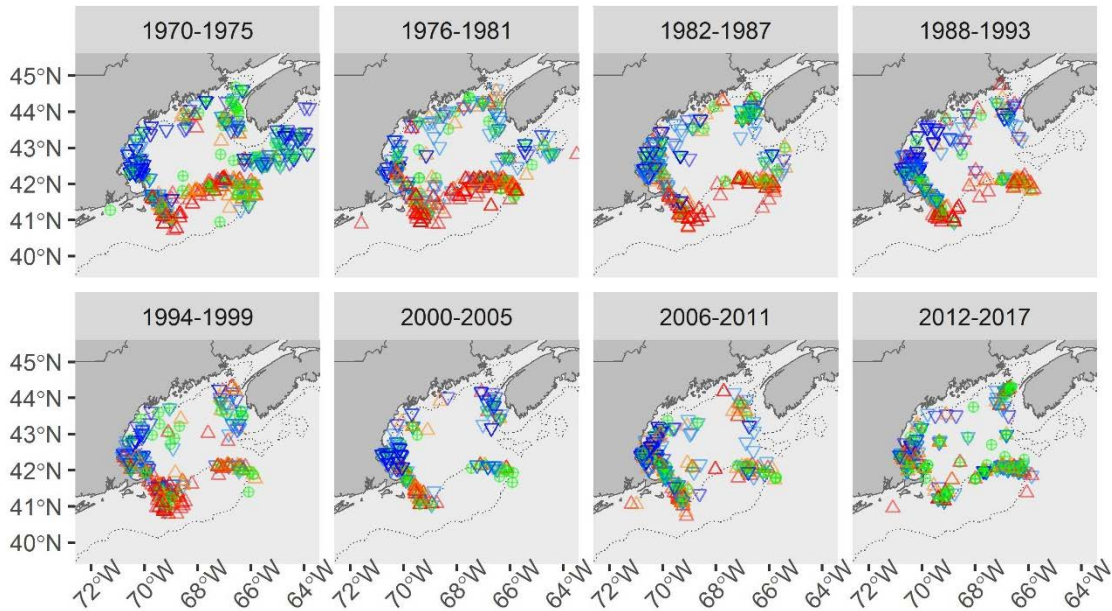


Figure 6. A closer look at the fall geographic distribution of female (top) and male (bottom) age-2 Atlantic cod, *Gadus morhua*, 1970-2017.

Sample sizes vary from period to period, reaching lowest values during 1994-2005, but > 200 fish were available to plot per sex, season, and period (Table 3).

Table 3: Number of age-2 Atlantic cod, *Gadus morhua*, by sex and 6-year seasonal periods, for all tows > 35°N, and the reduced number of fish from examining only the 'close-up' spatial scale (< 72°W and > 40°N, in parentheses).

| Period    | Spring    |            | Fall      |           |
|-----------|-----------|------------|-----------|-----------|
|           | Female    | Male       | Female    | Male      |
| 1970-1975 | 322 (285) | 1060 (822) | 242 (240) | 792 (688) |
| 1976-1981 | 487 (481) | 396 (390)  | 576 (575) | 479 (478) |
| 1982-1987 | 648 (648) | 533 (531)  | 536 (536) | 460 (460) |
| 1988-1993 | 384 (381) | 392 (388)  | 430 (430) | 380 (380) |
| 1994-1999 | 232 (231) | 217 (216)  | 403 (403) | 378 (378) |
| 2000-2005 | 250 (250) | 227 (227)  | 282 (282) | 217 (217) |
| 2006-2011 | 496 (495) | 422 (419)  | 455 (455) | 459 (459) |
| 2012-2017 | 441 (434) | 454 (452)  | 472 (472) | 440 (440) |

### Size at age 2 – cluster analysis

In spring, mean size of age-2 cod was lower in the Gulf of Maine management unit (range<sub>1970-1975</sub>: 28.1-36.5 cm; range<sub>2012-2017</sub>: 32.1-40.2 cm), than the Georges Bank management unit (range<sub>1970-</sub>

1975: 35.4-45.6 cm; range<sub>2012-2017</sub>: 35.4-45.1 cm) (Table 4). Fish from Gulf of Maine statistical areas 513 and 514 ranked among the smallest 3 means in both the first and last periods, but size at age 2 increased by 14-21% in both statistical areas between the first and last periods, 1970-1975 and 2012-2017, respectively. Modest increases in mean size at age 2 were also noted for cod in statistical area 521, areas 537-539, and areas 612-614. In contrast, fish from Georges Bank areas 522, 525, 561-2, were largest during 1970-1975, but size at age 2 decreased 13-19% in these 4 areas by 2012-2017. All this suggested spatial restructuring of the growth phenotypes between the beginning and end of the time series resulting in a narrowing of the differences in size at age 2 between the 2 management units.

Table 4. Spring adjusted sizes at age 2, for Atlantic cod, *Gadus morhua*, aggregated by statistical areas and by the first period, 1970-1975, and the most recent period, 2012-2017, of the NOAA bottom trawl survey. The Area\_stock label denotes the statistic area number (e.g., 500s are used in the current US stock assessment) and an abbreviated description of the area; see methods for further details. Size is reported as the mean (mean), standard deviation (sd), number of fish (*n*), and percent different in mean values between the 2 periods (% diff.). Percent differences are not calculated for areas with < 5 fish per area-period and will not be included in subsequent cluster analysis (Fig. 7).

| Area_stock   | 1970-1975 |      |          | 2012-2017 |      |          | % diff. |
|--------------|-----------|------|----------|-----------|------|----------|---------|
|              | mean      | sd   | <i>n</i> | mean      | sd   | <i>n</i> |         |
| 463-5 GOM-SS | 32.9      | 4.72 | 126      | 35.1      | 4.88 | 62       | 6.7     |
| 466-7 GOM-BF | 36.5      | 3.72 | 5        | 35.0      | 4.51 | 18       | -4.1    |
| 511 GOM-No.  | 32.8      | 1.91 | 2        | 36.5      | 5.71 | 30       |         |
| 512 GOM-No.  | 33.8      | 4.21 | 5        | 32.1      | 4.77 | 18       | -5.0    |
| 513 GOM-So.  | 29.4      | 4.62 | 8        | 33.6      | 6.65 | 47       | 14.3    |
| 514 GOM-So.  | 28.1      | 4.38 | 92       | 34.1      | 5.08 | 266      | 21.4    |
| 515 GOM-Ce.  | 35.7      | 3.36 | 2        | 40.2      | 4.58 | 81       |         |
| 521 GB-W     | 35.4      | 6.03 | 114      | 37.1      | 6.16 | 119      | 4.8     |
| 522 GB-W     | 45.6      | 4.68 | 64       | 37.0      | 5.06 | 25       | -18.9   |
| 525 GB-W     | 42.8      | 4.67 | 105      | 35.4      | 4.12 | 10       | -17.3   |
| 537-9 GB-SNE | 41.3      | 3.88 | 9        | 44.5      | 2.99 | 8        | 7.7     |
| 551 GB-E     | 41.8      | 4.59 | 185      | 37.3      | 5.08 | 121      | -10.8   |
| 552 GB-E     | 39.6      | 3.86 | 103      | 37.3      | 5.57 | 13       | -5.8    |
| 561 GB-E     | 43.4      | 5.59 | 92       | 37.6      | 5.06 | 47       | -13.4   |
| 562 GB-E     | 44.1      | 4.41 | 127      | 37.7      | 4.66 | 20       | -14.5   |
| 612-4 NYB    | 39.7      | 5.04 | 228      | 45.1      | 3.37 | 6        | 13.6    |

The results of the cluster analysis suggested that the spring adjusted sizes of age-2 cod during 1970-1975 were more spatially segregated between Georges Bank and the Gulf of Maine compared to 2012-2017 (Fig. 7). In the first period, 1970-75, the growth patterns of all statistical

areas on Georges Bank, except 521, were clustered separately from areas within the Gulf of Maine, but together with fish from southern New England and the New York Bight. Statistical area 521, which has been historically assigned as part of the Georges Bank management unit, is geographically in proximity to Cape Cod and the western part of the Great South Channel. In the most recent period, 2012-2017, spatial segregation of growth by statistical areas became less coherent. For example, while Gulf of Maine areas 512-515 clustered together, as did the southern New England and the New York Bight, the remaining Georges Bank and Gulf of Maine areas were mixed together in 1 large cluster.

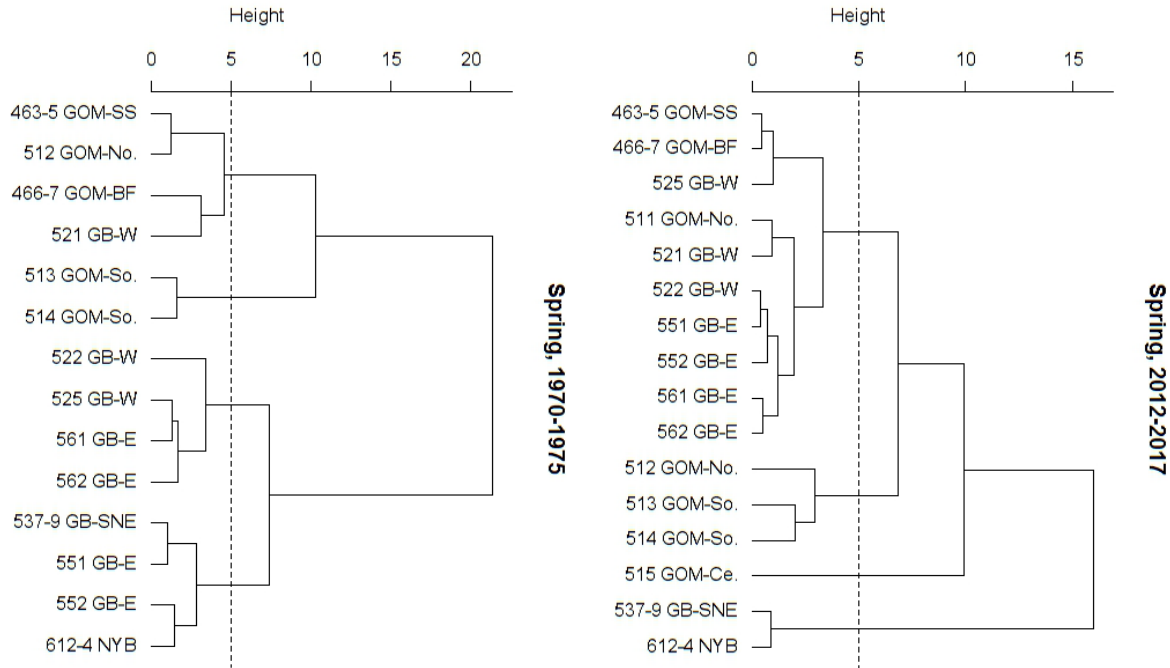


Figure 7. Divisive clusters of adjusted spring size at age 2 for Atlantic cod, *Gadus morhua*, aggregated by statistical catch areas (mean, sd; see Table 4). The Area\_stock label denotes the statistic area number (e.g., 500s are used in the US stock assessment) and an abbreviated description of the area; see methods for further details. Two periods are selected among the range of years: an early period (left) versus the most recent period (right). Statistical areas with low sample sizes (i.e., < 5 individuals/period; Table 4) were not included in the cluster analysis. An arbitrary height value of 5 is marked with a dashed line to aid in comparing between seasons and periods, and to demark an initial number of clusters.

In fall, mean size of age-2 cod was lower in the Gulf of Maine management unit (range<sub>1970-1975</sub>: 34.8-43.8 cm; range<sub>2012-2017</sub>: 43.0-47.6 cm), than in the Georges Bank management unit (range<sub>1970-1975</sub>: 45.9-53.2 cm; range<sub>2012-2017</sub>: 43.7-50.6 cm) (Table 5). As observed in spring catches, fish from statistical areas 513 and 514 ranked among the smallest 3 means in both the first and last periods, and size at age 2 increased in these 2 areas by 24-25% between the first and last periods, 1970-1975 and 2012-2017, respectively. Mean size at age 2 also increased in statistical area 521, but to

a lesser extent. In contrast, fish from Georges Bank areas 522, 551, 561 were very large during 1970-1975, but size at age 2 dropped 9-17% in these statistical areas by 2012-2017. Again, this suggested spatial restructuring of the growth phenotypes, specifically a narrowing of the range in sizes at age 2, between fish in the Gulf of Maine and Georges Bank management units from the beginning to the end of the time series.

Table 5. Fall adjusted sizes at age 2, for Atlantic cod, *Gadus morhua*, aggregated by statistical areas and by the first period, 1970-1975, and the most recent period, 2012-2017, of the NOAA bottom trawl survey. See Table 4 legend for details about column headers and Area\_stock labels.

| Area_stock   | 1970-1975 |      |          | 2012-2017 |      |          | % diff. |
|--------------|-----------|------|----------|-----------|------|----------|---------|
|              | mean      | Sd   | <i>n</i> | mean      | sd   | <i>n</i> |         |
| 463-5 GOM-SS | 41.3      | 5.66 | 104      | 43.9      | 6.02 | 44       | 6.3     |
| 466-7 GOM-BF | 43.8      | 4.46 | 29       | 47.6      | 5.62 | 26       | 8.7     |
| 511 GOM-No.  | 43.1      | 6.11 | 29       | 45.8      | 4.53 | 38       | 6.3     |
| 512 GOM-No.  | 43.6      | 8.37 | 24       | 43.3      | 8.39 | 8        | -0.7    |
| 513 GOM-So.  | 34.8      | 5.65 | 34       | 43.0      | 4.71 | 51       | 23.6    |
| 514 GOM-So.  | 34.8      | 5.81 | 219      | 43.6      | 5.70 | 208      | 25.3    |
| 515 GOM-Ce.  |           |      | 0        | 46.4      | 6.50 | 33       |         |
| 521 GB-W     | 45.9      | 6.98 | 205      | 49.0      | 5.85 | 129      | 6.8     |
| 522 GB-W     | 52.4      | 5.03 | 33       | 43.7      | 4.50 | 40       | -16.6   |
| 525 GB-W     | 53.2      | 8.24 | 3        |           |      | 0        |         |
| 537-9 GB-SNE | 46.5      |      | 1        | 56.3      |      | 1        |         |
| 551 GB-E     | 50.9      | 5.14 | 86       | 46.1      | 4.24 | 270      | -9.4    |
| 552 GB-E     | 47.2      | 4.57 | 37       | 50.6      | 8.41 | 2        |         |
| 561 GB-E     | 53.1      | 3.76 | 51       | 44.2      | 3.61 | 64       | -16.8   |
| 562 GB-E     | 50.3      | 2.98 | 11       |           |      | 0        |         |
| 612-4 NYB    | 47.6      | 4.00 | 90       |           |      | 0        |         |

Cluster analysis confirmed that fall adjusted size distributions of age-2 cod during 1970-1975 were more spatially segregated between Georges Bank and the Gulf of Maine management units compared to 2012-2017 (Fig. 8). Again, statistical area 521 stood out as not being classified with the Georges Bank management unit during 1970-1975, whereas fish from all the Georges Bank and Gulf of Maine statistical areas were jumbled together in a spatially incoherent manner during 2012-2017.

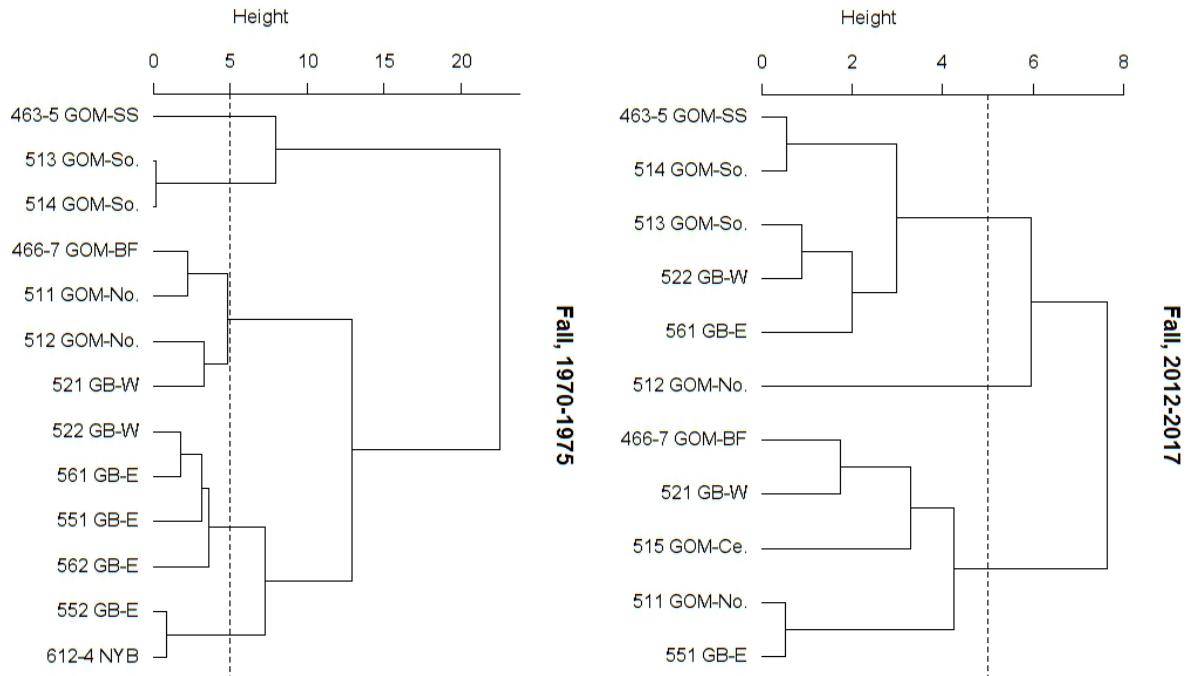


Figure 8. Divisive clusters of adjusted fall size at age-2 Atlantic cod, *Gadus morhua*, aggregated by statistical areas (mean, sd; see Table 5). Naming and graphic conventions are the same as in Fig. 7.

In summary, Atlantic cod size at age 2 increased substantially in several statistical areas of the Gulf of Maine management unit, but decreased substantially in several statistical areas on Georges Bank management unit from 1970-1975 to 2012-2017, which has weakened the growth signal that readily distinguished these 2 management units. Statistical area 521, assigned in US stock assessments to Georges Bank, was clustered repeatedly with Gulf of Maine assessment unit. Some fish from southern New England (537-539), which were assigned as part of the Georges Bank management unit, were clustered with either fish from Georges Bank (551, 552) or the New York Bight (612-614), both contiguous areas to southern New England. However, any inferences regarding the structure of cod in southern New England need to be treated with caution, given the paucity of samples in statistical areas 537-539.

Plotting individual cod size at age 2 depict fluctuations around a relatively stable value in the Gulf of Maine, including the Scotian Shelf, but the length of age-2 cod declined on both western and eastern Georges Bank, particularly evident in the spring (Fig. 9). As a result, at a broad-scale, size segregation at age 2 initially existed between cod within the Gulf of Maine and Georges Bank assessment boundaries but this devolved after approximately 2 decades and is no longer evident 50 years later.

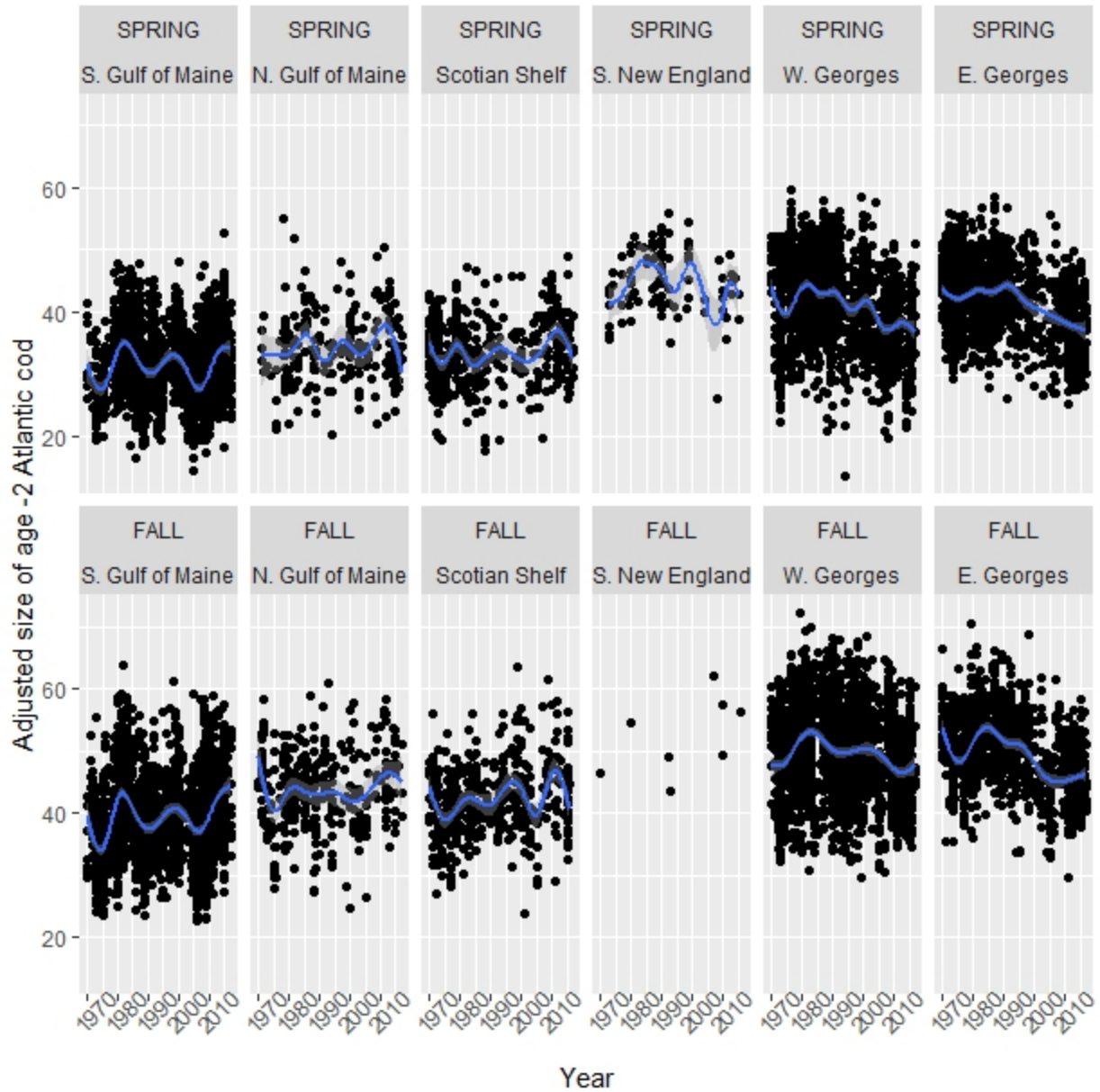


Figure 9. Annual trends in adjusted size (length, cm) of individual age-2 Atlantic cod, *Gadus morhua*, by region and season during the period 1970-2017. Data are aggregated by statistical areas into the following regions: Northern Gulf of Maine (511-512), Southern Gulf of Maine (513-514), Scotian Shelf (463-465), Southern New England (537-539), Western Georges Bank (521-2 & 525-6), and Eastern Georges Bank (551-2 & 561-2). The blue trend line is a Generalized Additive Model fit (' $y \sim s(x, bs = "cs")$ ') as part of the ggplot package in R (R Development Core Team, 2014).

### *Female maturity – descriptive*

Without consideration of the spatial structure of cod maturity, size at maturity was best explained when incorporating a time element. The base model with only length as a predictor of maturity (AIC = 9932), was markedly improved by adding 6-year periods to the model (AIC = 9230). The best performing model was the full model of fish length, time period, and their interaction (AIC = 9125).

The median size at maturity,  $L_{50}$ , initially at about 50 cm fork length, declined rapidly in the first few periods before appearing to stabilize at a lower value, around 40 cm (Table 6).

Table 6: Period-specific median size (cm) and age (years) at maturity ( $L_{50}$ ,  $A_{50}$ ), standard errors (SEs), and number of females ( $n$ ) used for fitting the logit model. Data are for Atlantic cod, *Gadus morhua*, from the spring NOAA bottom trawl survey.

| Period    | $L_{50}$ | SE( $L_{50}$ ) | $A_{50}$ | SE( $A_{50}$ ) | $n$  |
|-----------|----------|----------------|----------|----------------|------|
| 1970-1975 | 52.4     | 0.487          | 2.92     | 0.0501         | 1781 |
| 1976-1981 | 46.9     | 0.467          | 2.58     | 0.0407         | 2211 |
| 1982-1987 | 38.2     | 0.589          | 1.89     | 0.0452         | 2152 |
| 1988-1993 | 40.2     | 0.581          | 2.20     | 0.0440         | 1779 |
| 1994-1999 | 38.0     | 0.560          | 2.16     | 0.0480         | 1081 |
| 2000-2005 | 42.4     | 0.621          | 2.50     | 0.0535         | 1356 |
| 2006-2011 | 41.2     | 0.386          | 2.57     | 0.0368         | 2080 |
| 2012-2017 | 39.7     | 0.362          | 2.23     | 0.0375         | 2270 |

Age at maturity was also best explained when incorporating a time element. The base model with only age as a predictor of maturity (AIC = 11495), was markedly improved by adding 6-year periods to the model (AIC = 11046). The best performing model was the full model of fish age, time period, and their interaction (AIC = 11007).

The median age at maturity,  $A_{50}$ , initially at almost 3 years of age, declined a full year in the first 3 periods, 1970-1987, before appearing to stabilize at a lower value, around 2.2-2.5 years (Table 6).

In addition to this declining trend in length and age at maturity over time, the  $L_{50}$  and  $A_{50}$  values also varied spatially (Fig. 10). Estimates were restricted to  $1^{\circ} \times 1^{\circ}$  cells with  $>30$  individual females, and several cells with insufficient sample sizes to estimate maturation make it difficult to see a pattern within each period; however, in the following section, a spatial pattern is evident from cluster analysis based on statistical areas.



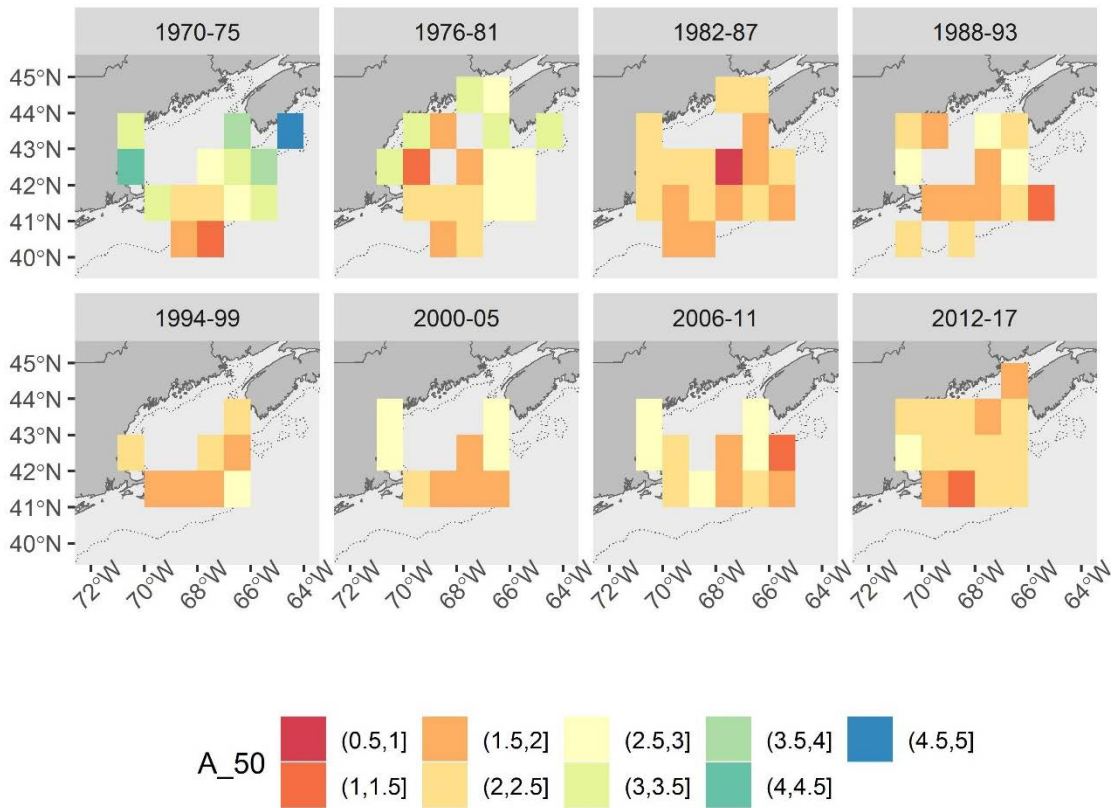
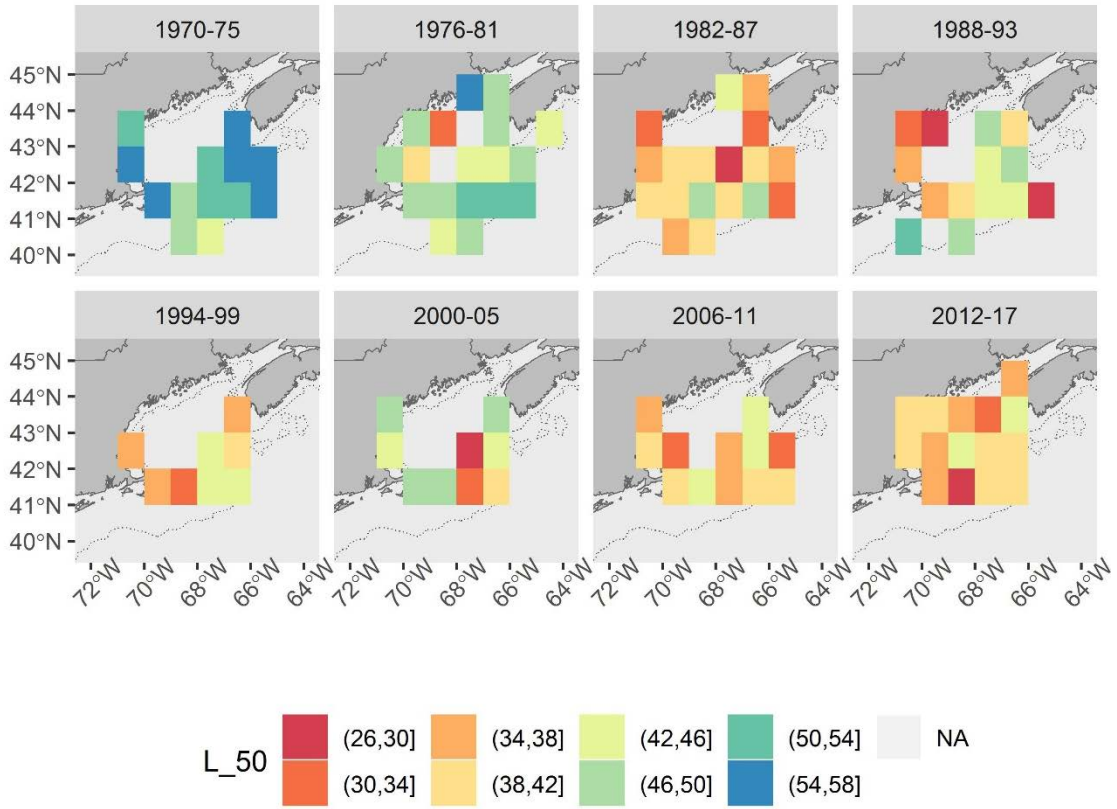




Figure 10. Modeled values of length ( $L_{50}$ , cm; top) or age ( $A_{50}$ , years; bottom) at maturity of female Atlantic cod, *Gadus morhua*, based on spring observations from the NOAA bottom trawl survey. Data were aggregated spatially in  $1^\circ$  (latitude and longitude) units north of  $40^\circ\text{N}$  and east of  $72^\circ\text{W}$ , as well as temporally in eight 6-year periods, 1970-2017.

### Female maturity – cluster analysis

Length at maturity was larger in the Gulf of Maine management unit than for fish in the Georges Bank management unit but only during 1970-1975 (range<sub>GOM</sub>: 54.3-57.6 cm; range<sub>GB</sub>: 44.5-55.7 cm) (Table 7). The  $L_{50}$  estimates were smaller and more overlapping between the areas during 2012-2017 (range<sub>GOM</sub>: 37.8-50.5 cm; range<sub>GB</sub>: 35.8-47.4 cm). The  $L_{50}$  estimate declined between these 2 periods in 9 out of 10 statistical areas, averaging -23% across all 10 statistical areas with sufficient data ( $n > 30$ ) to estimate parameters.

Table 7. Estimates of size at maturity for female Atlantic cod, *Gadus morhua*, by statistical areas and by an early period, 1970-1975, and the most recent period, 2012-2017, of the NOAA bottom trawl survey time series. See methods for description on the Area\_stock label. Size is reported as the median length at maturity ( $L_{50}$ ), standard error (SE), number of fish ( $n$ ), and percent different in mean values between the 2 periods (% diff.). Values were not estimated if the number of fish was  $\leq 30$ .

| Area_stock   | 1970-1975 |      |     | 2012-2017 |      |     | % diff. |
|--------------|-----------|------|-----|-----------|------|-----|---------|
|              | $L_{50}$  | SE   | $n$ | $L_{50}$  | SE   | $n$ |         |
| 463-5 GOM-SS | 56.0      | 1.26 | 305 | 39.2      | 1.79 | 168 | -30.0   |
| 466-7 GOM-BF |           |      | 19  |           |      | 30  |         |
| 511 GOM-No.  |           |      | 15  | 37.8      | 2.25 | 33  |         |
| 512 GOM-No.  |           |      | 16  | 50.5      | 9.27 | 35  |         |
| 513 GOM-So.  | 57.6      | 2.47 | 75  | 42.3      | 1.23 | 197 | -26.6   |
| 514 GOM-So.  | 54.3      | 2.54 | 144 | 40.1      | 0.55 | 687 | -26.2   |
| 515 GOM-Ce.  |           |      | 12  | 40.2      | 1.41 | 150 |         |
| 521 GB-W     | 51.7      | 1.69 | 123 | 37.3      | 1.08 | 175 | -27.9   |
| 522 GB-W     | 51.0      | 2.93 | 130 | 36.5      | 2.85 | 70  | -28.4   |
| 525 GB-W     | 47.3      | 3.81 | 106 | 35.8      | 2.84 | 31  | -24.3   |
| 537-9 GB-SNE |           |      | 18  |           |      | 16  |         |
| 551 GB-E     | 55.7      | 0.98 | 226 | 39.2      | 0.93 | 318 | -29.6   |
| 552 GB-E     | 44.5      | 0.91 | 74  | 47.4      | 2.02 | 119 | 6.5     |
| 561 GB-E     | 53.1      | 2.40 | 48  | 41.0      | 1.84 | 151 | -22.8   |
| 562 GB-E     | 48.7      | 1.19 | 128 | 39.4      | 1.63 | 70  | -19.1   |

|           |      |      |     |  |  |   |
|-----------|------|------|-----|--|--|---|
| 612-4 NYB | 47.6 | 1.23 | 181 |  |  | 7 |
|-----------|------|------|-----|--|--|---|

Cluster analysis demonstrated that the length at maturity distributions were well segregated between the Gulf of Maine and Georges Bank in both periods (Fig. 11). However, there was evidence of variation within the Georges Bank management unit, because statistical areas 521-22 (western Georges Bank) clustered more closely with the Gulf of Maine statistical areas than with the eastern Georges Bank statistical areas. Females from area 512 in 2012-2017 had a particularly high  $L_{50}$ , resulting in an independently assigned cluster for this area in the Gulf of Maine

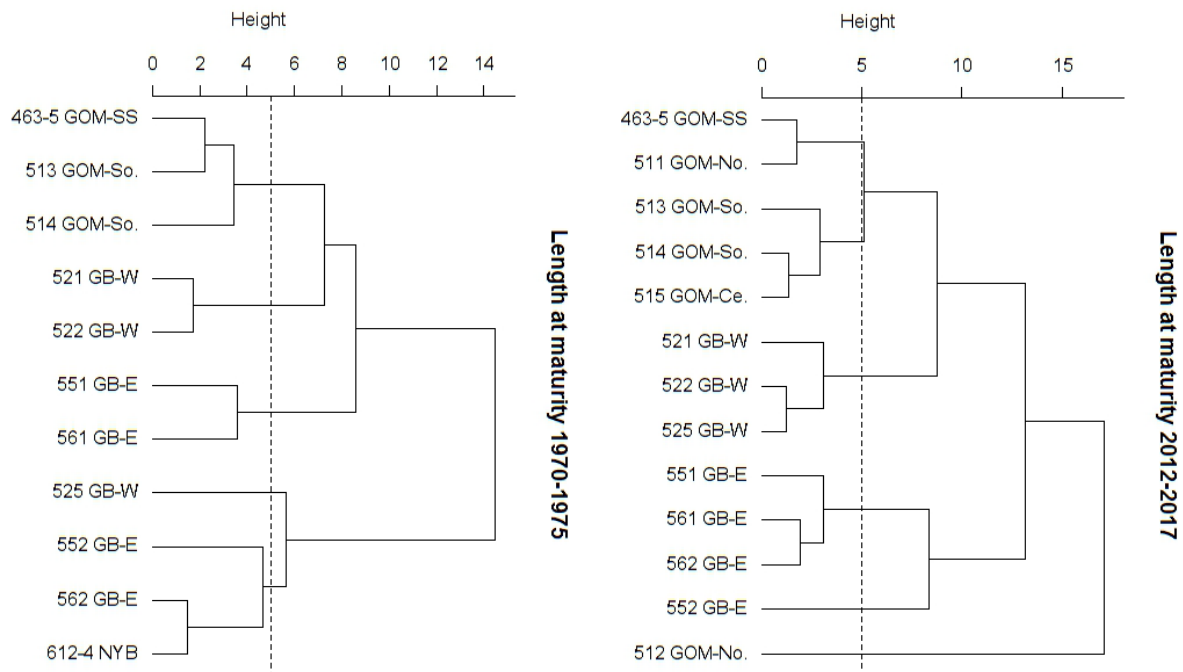


Figure 11. Divisive clusters of length at maturity (median, standard error) for female Atlantic cod, *Gadus morhua*, collected in spring and aggregated by statistical areas. The Area\_stock label denotes the statistical area number (e.g., 500s are used in the US stock assessment) and an abbreviated description of the area; see methods for further details. Two periods are selected among the range of years: an early period (left) versus the most recent period (right). Statistical areas with low sample sizes (i.e.,  $\leq 30$  females/period; Table 7) were not included in the cluster analysis. An arbitrary height value of 5 is marked with a dashed line to add in comparing between seasons and periods, and to demark an initial number of clusters.

Age at maturity was older in the Gulf of Maine management areas than in the Georges Bank management areas but only during 1970-1975 (range<sub>GOM</sub>: 3.7-4.4 yr; range<sub>GB</sub>: 1.9-2.9 cm) (Table 8). The  $A_{50}$  estimates were younger and overlapping between the areas during 2012-2017

(range<sub>GOM</sub>: 1.9-2.9 cm; range<sub>GB</sub>: 1.7-2.8 cm). The  $A_{50}$  estimate declined between these 2 periods in 8 out of 10 statistical areas, averaging -23% across all 10 statistical areas.

Table 8. Estimates of age at maturity for female Atlantic cod, *Gadus morhua*, by statistical areas and by an early period, 1970-1975, and the most recent period, 2012-2017, of the NOAA bottom trawl survey. Naming conventions follow that of Table 7.

| Area_stock   | 1970-1975 |       |     | 2012-2017 |       |     | % diff. |
|--------------|-----------|-------|-----|-----------|-------|-----|---------|
|              | $A_{50}$  | SE    | $n$ | $A_{50}$  | SE    | $n$ |         |
| 463-5 GOM-SS | 3.74      | 0.128 | 305 | 2.16      | 0.150 | 168 | -42.2   |
| 466-7 GOM-BF |           |       | 19  |           |       | 30  |         |
| 511 GOM-No.  |           |       | 15  | 1.94      | 0.178 | 33  |         |
| 512 GOM-No.  |           |       | 16  | 2.86      | 0.374 | 35  |         |
| 513 GOM-So.  | 3.88      | 0.332 | 75  | 2.45      | 0.114 | 197 | -36.9   |
| 514 GOM-So.  | 4.41      | 0.277 | 144 | 2.54      | 0.062 | 687 | -42.4   |
| 515 GOM-Ce.  |           |       | 12  | 2.13      | 0.105 | 150 |         |
| 521 GB-W     | 2.91      | 0.109 | 123 | 1.87      | 0.107 | 175 | -35.7   |
| 522 GB-W     | 2.49      | 0.197 | 130 | 1.71      | 0.388 | 70  | -31.3   |
| 525 GB-W     | 1.89      | 0.446 | 106 | 1.77      | 0.504 | 31  | -6.3    |
| 537-9 GB-SNE |           |       | 18  |           |       | 16  |         |
| 551 GB-E     | 2.88      | 0.092 | 226 | 2.06      | 0.120 | 318 | -28.5   |
| 552 GB-E     | 2.48      | 0.132 | 74  | 2.85      | 0.203 | 119 | 14.9    |
| 561 GB-E     | 2.57      | 0.237 | 48  | 2.06      | 0.265 | 151 | -19.8   |
| 562 GB-E     | 2.30      | 0.105 | 128 | 2.35      | 0.163 | 70  | 2.2     |
| 612-4 NYB    | 2.47      | 0.892 | 181 |           |       | 7   |         |

Cluster analysis demonstrated that the age at maturity distributions were well segregated between the Gulf of Maine and Georges Bank in both periods (Fig. 12). Again, in the early period, 1970-1975), statistical areas 521-522 clustered more closely with the Gulf of Maine management unit. However, in the most recent period (2012-2017), the 4 major clusters were almost perfectly ordered: 1) northern Gulf of Maine, 2) southern/central Gulf of Maine, 3) western Georges Bank (with 551 from eastern Georges), and 4) eastern Georges Bank.

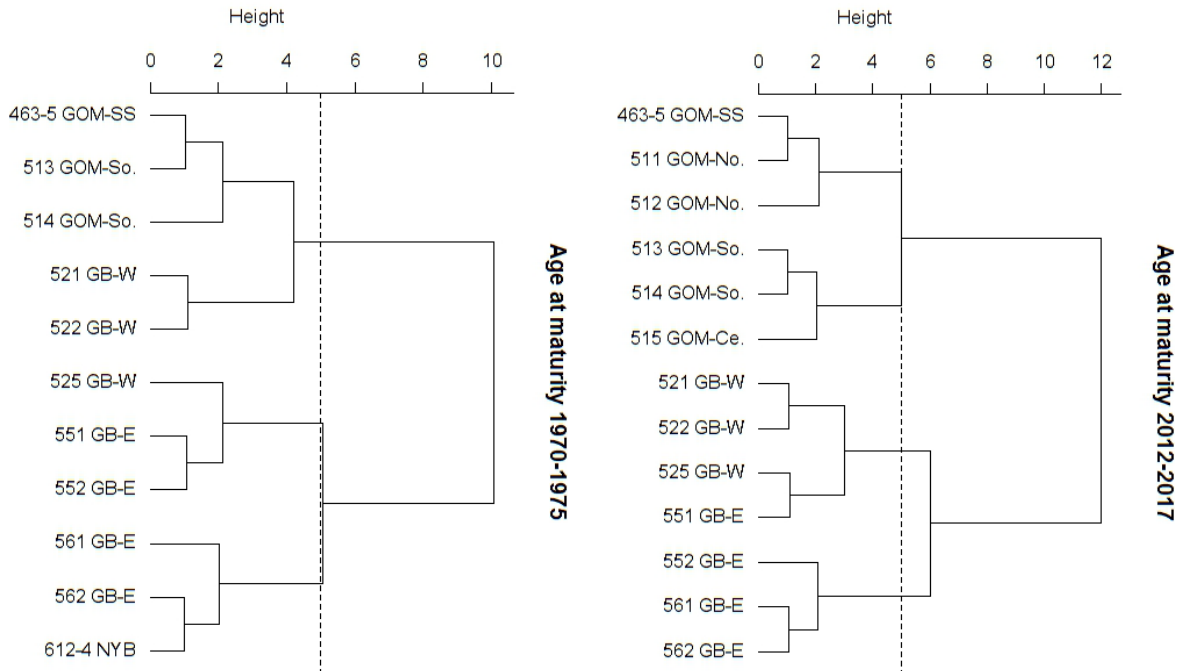


Figure 12. Divisive clusters of age at maturity (median, standard error) for female Atlantic cod, *Gadus morhua*, collected in spring and aggregated by statistical areas. Groups and labeling follow that of Fig. 11.

In summary, despite spatially broad, double-digit percentage declines in both  $L_{50}$  and  $A_{50}$ , from 1970-1975 to 2012-2017, the spatial segregation of both length and age at maturity clustered into either the Gulf of Maine and Georges Bank assessment units, except that in 3 of the 4 comparisons, parts of the western Georges – particularly areas 521 and 522 – clustered more closely with Gulf of Maine areas. Assignment of southern New England areas (537-539) was not possible in either period due to low sample size, but the adjoining New York Bight area (612-614) did align with Georges Bank during 1970-1975.

## Discussion

This study examined a single source of sampling over a broad scale of space and time – from Cape Hatteras, US, to Cape Sable, Canada, over a 48-year period – demonstrating spatial and temporal dynamics in 3 life history traits of Atlantic cod: distribution and abundance, size at age 2, and size and age at maturity. Because measures of abundance and vital rates are inputs to regional cod stock assessments, they have been monitored regularly for decades and they were considered in early efforts to delineate cod stocks. Our historical review confirms that all 3 life history traits have changed since the 1970s, which emphasizes the need for this re-evaluation and for continued monitoring in the future.

### *Distribution and abundance*

Most reports reiterate Earll's (1880) southern distributional limit as Cape Hatteras (35°N). In this analysis, we uncovered unpublished records from a single cruise in November-December, 1972, that recorded cod south of Cape Hatteras, as far south as northern Florida (30°N). This event is unusual and appears to be the result of a strong year class in the early 1970s (Serchuk and Wood 1979), as well as sampling an unusual cruise track, both in southern range of stations and late into winter conditions. In most years the southern distributional record was well north of 35°N. The overall pattern of decreasing abundance with decreasing latitude south of 40°N is most likely associated with the temperature tolerance of Atlantic cod (Fig. 13); cod's total thermal niche, -1.5 to 19 °C (Righton et al. 2010; Zemeckis et al. 2017), is not broad enough to occupy temperatures along the Middle Atlantic seaboard year round, which seasonally gets warmer than 20 °C (Friedland and Hare 2007; McBride 2014b). Moreover, cod has a narrower niche (1-8 °C) during the spawning season and an optimal growth range of 8-10 °C (Righton et al. 2010).

Within-year geographic shifts, suggesting seasonal migration, have also been noted (e.g., Grosslein 1973; data herein). Temperature shifts from spring to fall (Fig. 13) are likely the driver of strong seasonal shifts in distribution and abundance (e.g., cod move off the southern flank of Georges Bank in fall). Temperatures associated with capture of age-2 cod are higher in fall than in spring (< 15 versus < 10 °C; Fig. 14). One segment of the cod population that has suffered, in particular, is what Wise (1963) regarded 'the New Jersey coastal cod,' a distinct group that migrated to southern New England during the warmer months; this group is greatly reduced in abundance based on distributional maps.

The southern distributional limit of cod moved northward from 1970 to about 2000, and since the 1990s, very few cod were observed south or west of Block Island Sound (approximately 41.3°N, 71.7°W). This may be due to interactions between a warming trend along the US east coast (Friedland and Hare 2007; Pershing et al. 2015; Miller et al. 2018) and the declining abundance of cod, as in the case of the Georges Bank cod management unit, spawning stock biomass declined from 60-90,000 metric tons (mt) during 1970-1990 to < 30,000 mt during 2000-2010 (NEFSC 2012).

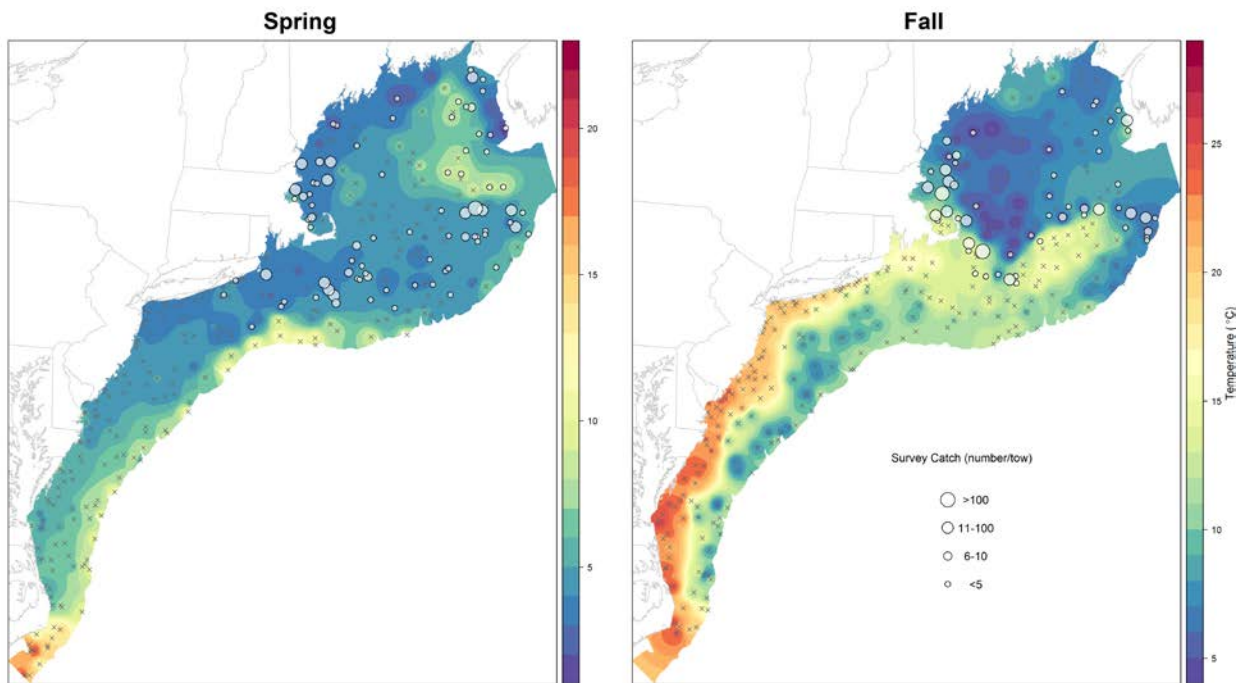


Figure 13. Seasonal distribution of Atlantic cod, *Gadus morhua*, in relation to modeled *in situ* bottom temperature in during 2004.

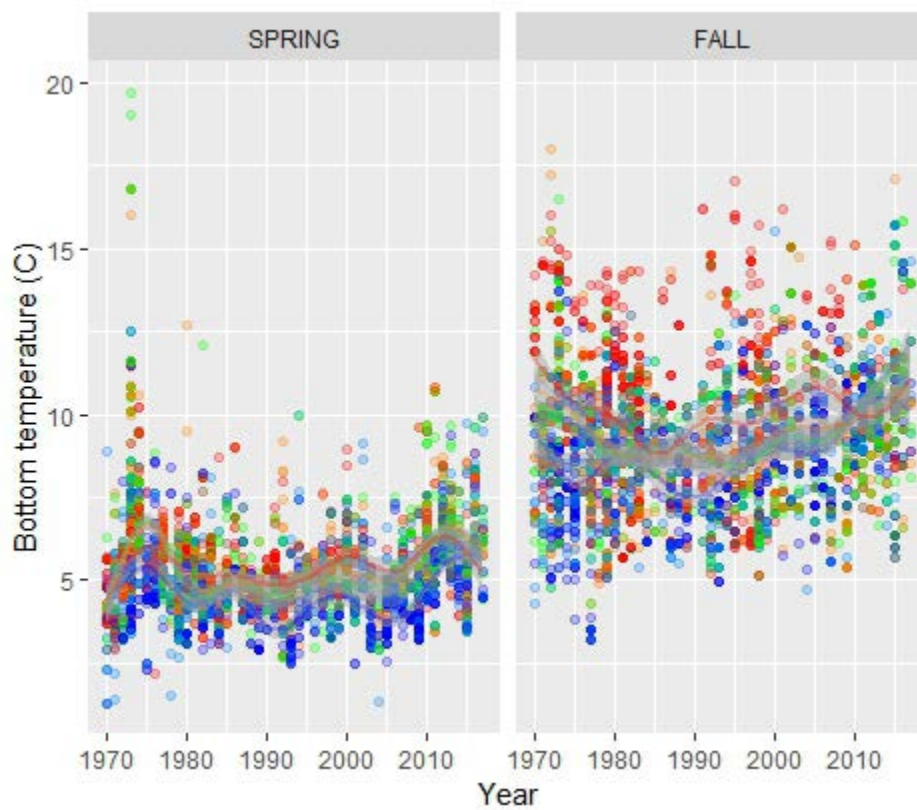


Figure 14. Age-2 Atlantic cod were associated with different bottom temperature at capture during spring (right) and fall (left) seasons. No annual trend was evident from 1970 to 2017 but larger fish were found in warmer temperatures. The points are color coded by size at age 2 as in Fig. 1, and the predictive, solid lines (with shaded 95% confidence intervals) are fit to the data by general additive modeling in R.

Also evident during the last 5 decades, 1970-2017, the cod population has aggregated into 2 areas: 1) the southwest part of the Gulf of Maine and extending into the Great South Channel, and 2) on the northeast peak of Georges Bank. Depletion of entire spawning groups along the Maine coast was documented by Ames (2004) and Alexander et al. (2009), and abundance in this region has fluctuated at very low levels since the 1970s. Concentration of cod on Georges Bank appears to be more recent, witnessed during the 1970-2017 period. These patterns of aggregation were also noted by Begg et al. (1999), examining data from 1967 to 1997, who attributed this to declining population size. Notable among the plots of geographic distribution is the continuous aggregation of cod from the southern Gulf of Maine, around lower Cape Cod, and into the Great South Channel because this aggregation spans statistical areas 514 and 521, which are assigned to the Gulf of Maine and Georges Bank management units, respectively (Fig. 15). The continuous distribution of cod from the southern Gulf of Maine, to the east of Cape Cod, and into the Great South Channel was also identified by several fishermen (DeCelles and Ames, this TM).



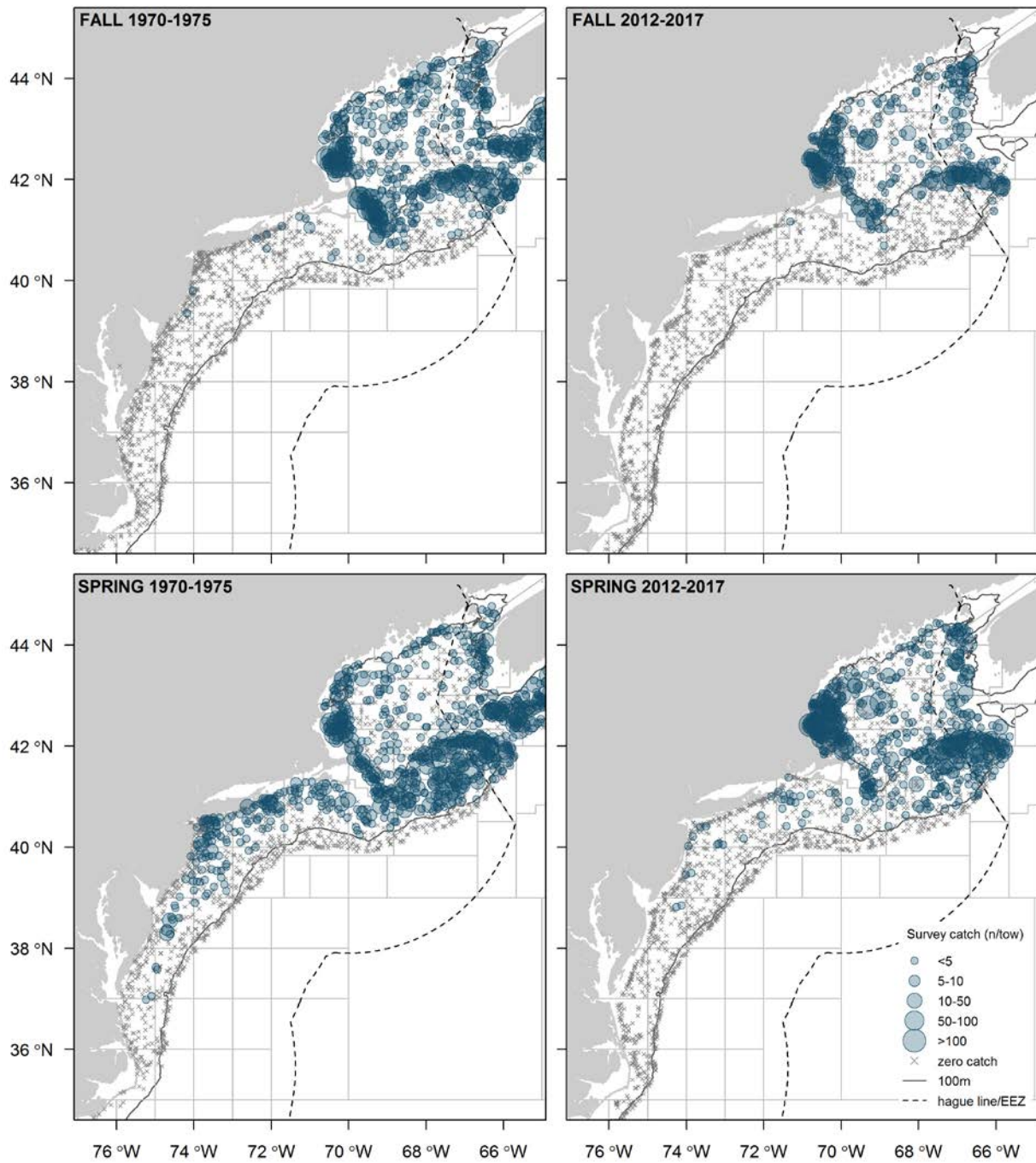


Figure 15. Distribution and abundances (number of fish per tow) of Atlantic cod, *Gadus morhua*, during the first period, 1970-1975, and the most recent period, 2012-2017, of the NOAA bottom trawl survey during fall (top) and spring (bottom). Overlaid are the statistical area boundaries. See [Cournane et al. \(this TM\)](#) for more details on areas.



## *Size at age 2*

Size at age 2 varied widely among cod, from 14 to 72 cm, and was related to both sampling location and period. Cod from the Gulf of Maine management unit were consistently smaller than those from the Georges Bank unit, but the degree of difference changed during the time series. Size at age differences were first noted for young cod by Penttila and Gifford (1976), who reported that cod collected during 1970-1974 from eastern Georges Bank were significantly larger than cod from western Georges Bank cod (southern New England, including the Great South Channel), which were in turn larger than cod from the Gulf of Maine management unit. These differences were consistent (both seasons) for age-1 and age-2 cod, less so for age-3 and older fish. Begg et al. (1999) reported similar results – that growth rates were highest for eastern Georges Bank, typically greater than western Georges Bank, and lowest for Gulf of Maine – based on interpreting the Brody coefficient from the von Bertalanffy model. Tallack (2009) also reported strong differences in growth among the Gulf of Maine, Georges Bank, and Bay of Fundy management units, as well as within unit variation between western and eastern George Bank, based on tag recaptures from 2003 to 2008.

In reference to the current 2-management units used domestically in the US, our re-examination of 1970-1975 data found size at age 2 in statistical area 521 misaligned with the areas within the Georges Bank management unit; instead it clustered with Gulf of Maine areas. This suggests that the differences between western and eastern Georges Bank is driven largely by a misalignment of a single statistical area to the western Georges Bank, which is potentially influenced by connectivity with the southern Gulf of Maine.

Dean et al. (this TM) concluded that there is connectivity of cod early life stages between the Gulf of Maine and statistical area 521, based on their examination of the spatial and temporal distribution of cod larvae, a review of larval transport studies, and correlation analyses. They conclude that the majority of observed settlement in statistical area 521 originates from spawning events in the Gulf of Maine. Cadrin et al. (this TM) also note that adults tagged in statistical area 521 move in all directions, including between the two management units. The high degree of cod larvae dispersal and adult movements around Cape Cod, provide a mechanistic explanation for why cod life history in this statistical area is often clustered with the Gulf of Maine management unit, instead of the Georges Bank unit to which this statistical area is assigned.

Up to about 2010, a size at age signal existed between 3 areas: Gulf of Maine, western Georges Bank, and eastern Georges Bank. However, this historic area-specific growth signal has broken down since, to the point that strong differences between these 3 areas have diminished and that size at age 2 is relatively homogeneous between US statistical areas in the last decade or so. Three process hypotheses may explain this: 1) warming in this region has become physiologically stressful, more so on Georges Bank than in the Gulf of Maine; 2) the composition of spring- versus winter-spawners has changed over time, favoring the latter which are larger at the first few age classes and more common in the Gulf of Maine management unit; or 3) prolonged and intense fishing has removed faster growing fishing genotypes, resulting in fishing-induced evolution, which is most evident for the Georges Bank cod stock. There is also a measurement error

hypothesis: that the switch from the FSV Albatross IV to the Henry Bigelow had led to reduced differences between regions. We explore each of these hypotheses in detail below.

Warming in this region has been recognized repeatedly in both the Gulf of Maine and Georges Bank management units with potential effects on Atlantic cod (Pershing et al. 2015, Miller et al. 2018, Sguotti et al. 2019). Nonetheless, Miller et al. (2018) modeled growth of Georges Bank cod during spring, 1970-2014, and showed that bottom temperature positively affected size at age during the first year of life, which does not suggest that temperatures on Georges Bank have reached some threshold that would reduce cod growth in this management unit. We reject hypothesis 1 as a causative factor slowing growth of Georges Bank cod.

It is possible that size at age 2 shifts over time arise in areas that were dominated historically by spring-spawning cod but are dominated now by winter-spawned cod. This may occur in selected statistical areas, where spawning occurs in both the spring and winter, because the winter-spawned cod experience nearly a full year, whereas the spring-spawned cod experience only a partial year, before the first annulus is marked on their otolith. Consequently, winter-spawned cod are larger at a common age in the first few years, when age is assigned by examining otoliths. Dean et al. (in press) developed an otolith-based method to discriminate between these spawning cohorts in the Gulf of Maine, and did find that spring-spawned cod were the dominant cohort during the 1980s and through the mid-1990s, after which the winter-spawned cohort became dominant to today. While this reveals a mechanism for why size at age may have increased in at least certain statistical areas of the Gulf of Maine during this time period, it does not explain why size at age 2 decreased on Georges Bank.

Cod in both management units have experienced high mortality over time, which has led to lower spawning stock biomass and numbers overall. Reduced density may promote faster growth if resources become more available, either relatively or absolutely. However, faster growth was only suggested in the Gulf of Maine, and it may be conflated with spawning origin if an increase size at age 2 is the result in shifting composition of spring versus winter-spawned cohorts. More concerning is that high fishing mortality has removed fast-growing genotypes out of the population, which has been reported for many marine populations, including US stocks of cod (i.e., fishing-induced evolution; Barot et al 2004). Presumably this is happening to cod in both management units, and if so, historically reduced size at age 2 will likely persist for decades, even after lowering fishing mortality, confounding the historical growth signal of cod stock structure as well as reducing fisheries yield for each stock (Law 2000, Conover et al. 2009).

Finally, measurement error is a concern due to the various changes that occur during the 48-year time series. We focus here on the switch between FSV Albatross IV in 2008 and transfer of operations to the FSV Henry Bigelow. The latter catches more cod and these are smaller and younger than catches by the former (Brooks et al. 2010), which could result in a bias of slower growing cod being caught. Qualitatively, this does not appear to be the case. First, the shift to slower growing fish on Georges Bank is evident in the period 2000-2005 (Figs. 5, 6), before the switch in vessels. Second, it is not clear why this calibration issue would lead to larger fish in the Gulf of Maine but smaller fish in the Georges Bank management unit. Third, the cod that are aged are sampled in a stratified-random manner with respect to length bins, which would down-weight the influence of Bigelow sampling more smaller, younger cod. A more qualitative

analysis would require reconstructing the original samples and simulating the size at age of subsampled cod, which is beyond the scope of this study, and will not necessarily lead to a different conclusion, but we discuss it here to be complete.

### *Female maturity*

Historical estimates of age at female maturity showed that Gulf of Maine cod had the oldest age at maturity: 4 years, Gulf of Maine (Cape Ann, Massachusetts); 3.5, Browns Bank; 2.9, Georges Bank (Earll 1880; Livingston and Dery 1976). Over time, median length and age at maturity declined dramatically based on the analyses here and those published elsewhere (Hunt 1996; Begg et al. 1999; O'Brien 1999; Barot et al. 2004; Miller et al. 2018).

Although such temporal trends have been associated with increasing water temperatures for some marine species (Goldberg et al. 2019), bottom temperature did not improve modeling of maturity parameters for Georges Bank cod (Miller et al. 2018). As pointed out for size at age 2, it is more likely that this decrease in both  $L_{50}$  and  $A_{50}$  is a response to overfishing of these populations, which has been seen in many heavily exploited fishes (Trippel 1995; Laugen et al. 2014). Although age at maturity in the most recent period, 2012-2017, was highly structured into 4 largely geographically coherent clusters, the spatial tendency is for  $L_{50}$  (both periods) and  $A_{50}$  (1970-1975) from western Georges Bank statistical areas to cluster with Gulf of Maine areas. This supports a misalignment of select western areas, particularly statistical areas 521-522, within the Georges Bank management unit.

### *Overview of the approach*

A strength of these analyses is the use of a single time series, across nearly 5 decades and over a relevant spatial scale, using standard methods to examine abundance, size at age 2, and maturity schedules. A mixed set of data sources could have been used if statistical sampling designs were appropriately matched or adjusted throughout the time series and corresponding quality checks occurred for sample processing between laboratories. For example, Du Pontavice et al. (2018) integrated fishery-independent (survey beam trawl) and fishery-dependent (commercial landings) sources and calibrated the results during a short period, 2010-2015, of sampling. We considered including other datasets, but none started as early as the NOAA bottom trawl survey, among other differences that would need rigorous testing to rule out sampling artifacts from pooling the data.

Another strength is to aggregate the data in a hierarchical manner to test for coherence between fine-scale statistical areas and large-scale management units. Specifically, we employed cluster analysis to look for coherence between the data assigned to nested spatial units, as outlined by Cope and Punt (2009) for common fishery data. A corollary to using finer-scale measurements is that we avoided model-based estimates of growth because Begg et al. (1999) noted unrealistic estimates of von Bertalanffy growth parameters when samples sizes were low in the 1990s, even when the data were pooled by only the 2 management units. Bayesian methods may assist in fitting realistic parameters to such data-limited situations, but the application of this approach by Adams

et al. (2018) reported the greatest uncertainty for sampling units that had the smallest sample sizes, which constrains the inference possible for testing alternative stock structure hypotheses.

There are some weakness of this analysis, including limited sample sizes in some statistical areas, particularly but not limited to areas of the New York Bight, southern New England, Browns Bank, and the central Gulf of Maine. Still, the clustering approach followed guidelines proposed by Cope and Punt (2009) to use multiple years of data per period and samples with low coefficients of variation. Also, the origin of season spawning – spring versus winter – is not directly known in our samples, but as discussed, this may explain the temporal instability of the size at age results. Finally, in concordance with temperatures rising, the forage for cod may be shifting, as documented for larval cod by Friedland et al. (2013), but the effects of these ecosystem shifts on cod life history traits and stock structure cannot be explored at this time.

These temporal dynamics in Atlantic cod life history are highly relevant for assessment and management because they affect yield. At a very broad-scale, there is a spatial pattern in these life history traits that supports at least 2 management units. However, the temporal instability of growth and maturation rates raise additional questions. Growth and maturation rates arise from both environmental and genetic components that may be difficult to tease apart (Swain and Foote 1999; Begg 2005). Life history parameters may change over ecological time scales due to environmental influences (e.g., temperature) or population dynamics (e.g., density-dependence) (McBride 2014a), and they can be subject to fisheries-induced evolution (Kuparinen and Merila, 2007; Enberg et al., 2009) or phenotypic plasticity (e.g., Grabowski et al., 2009). Continued sampling is warranted to determine if these changes arise from environmental plasticity, which may rebound quickly if conditions revert to original settings, or from fishing-induced evolution, which may only reverse in response to reduced fishing pressure over several generations of cod.

## Conclusions

The value of life history traits as inputs to stock assessment has resulted in decades of monitoring data across relevant spatial scales, revealing spatial and temporal dynamics of abundance and distribution, size at age 2, and size and age at maturity. This re-evaluation of these specific life history traits supports earlier divisions of Atlantic cod into at least 2 management units, but also suggests that select areas of western Georges Bank are not only different than eastern Georges, they are more aligned with the Gulf of Maine. The loss of the size-at-age ‘stock structure signal’ over time is confounding, and brings up the question of whether this arises from environmental plasticity, which may rebound quickly if conditions revert to original settings, or from fishing-induced evolution, which may only reverse in response to reduced fishing pressure over several generations of cod.

Life history patterns contribute to our interdisciplinary review of cod stock structure but do not appear to be leading indicators identifying stock structure of cod. In particular, the significant temporal and spatial dynamics in these life history traits, coupled with low sample sizes in specific period-area combinations, make them more of a complementary approach to consider among the other disciplines.

Regardless, the dynamic nature of the specific life history traits analyzed here suggest they could continue to change in the future, and thereby continue to inform stock structure, stock assessment, and fishery management. It appears that current allocations of sampling in recent years have achieved well-balanced sample sizes across areas, which should be maintained. Alignment of future life history trait analysis within an interdisciplinary context is recommended as a process-oriented approach to investigate stock structure and dynamics of Atlantic cod.

## Acknowledgments

Many hands collected and maintained these data over the decades, with specific thanks to the NOAA corps, all hands on the research vessels, the support at sea and on land by the Northeast Fisheries Science Center. S. Hardison provided valuable advice with R coding, and M. Traver and M. Wuenschel offered helpful comments on an earlier draft.

## References Cited

Adams GD, Leaf RT, Ballenger JC, Arnott SA and McDonough CJ. 2018. Spatial variability in the growth of Sheepshead (*Archosargus probatocephalus*) in the Southeast US: Implications for assessment and management. *Fish Res.* 206: 35-43. <https://doi.org/10.1016/j.fishres.2018.04.023>

Alexander KE, Leavenworth WB, Cournane J, Cooper AB, Claesson S, Brennan S, Smith G, Rains L, Magness K, Dunn R, Law TK, Gee R, Bolster WJ and Rosenberg AA. 2009. Gulf of Maine cod in 1861: historical analysis of fishery logbooks, with ecosystem implications. *Fish Fish.* 10: 428-449. <https://doi.org/10.1111/j.1467-2979.2009.00334.x>

Ames EP. 2004. Atlantic cod stock structure in the Gulf of Maine. *Fisheries.* 29: 10-28. [http://www.nefsc.noaa.gov/GARM-Public/2.%20Models%20Meeting/background/Atlantic%20Cod%20Structure%20in%20the%20Gulf%20of%20Maine%20\\_Ted%20Ames\\_Fisheries%20\\_Jan%202004.pdf](http://www.nefsc.noaa.gov/GARM-Public/2.%20Models%20Meeting/background/Atlantic%20Cod%20Structure%20in%20the%20Gulf%20of%20Maine%20_Ted%20Ames_Fisheries%20_Jan%202004.pdf)

Altukhov, Y. P. 1981. The stock concept from the viewpoint of population genetics. *Canadian Journal of Fisheries and Aquatic Sciences*, 38: 1523–1538.

Andrushchenko, I., C.M. Legault, R. Martin, E.N. Brooks, and Y. Wang. 2018. Assessment of eastern Georges Bank Atlantic cod for 2018. Transboundary Resource Assessment Committee Reference Document 2018/01, 97 p.

Annala, J. 2012. Report of the Workshop on Stock Structure of Atlantic Cod in the Gulf of Maine Region, 12–14 June 2012. Portsmouth, NH. <https://www.gmri.org/resources/resource-archive/cod-stock-structure-workshop-report> (data accessed 29 March 2019).

Azarovitz TR. 1981. A brief historical review of the Woods Hole laboratory trawl survey time series. Canadian Special Publication of Fisheries and Aquatic Sciences. 58: 62-67. [http://dmoserv3.whoi.edu/data\\_docs/NEFSC\\_Bottom\\_Trawl/Azarovitz1981.pdf](http://dmoserv3.whoi.edu/data_docs/NEFSC_Bottom_Trawl/Azarovitz1981.pdf)

Barot S, Heino M, Brien LO and Dieckmann U. 2004. Long-term trend in the maturation reaction norm of two cod stocks. *Ecol Appl*. 14: 1257-1271. <https://esajournals.onlinelibrary.wiley.com/doi/10.1890/03-5066>

Begg, G. A. 2005. Life history parameters. In *Stock Identification Methods*, 1st edn, pp. 119–150. Ed. by S. X. Cadrin, K. Friedland, and J. R. Waldman. Elsevier, San Diego. 736 pp.

Begg, G. A., and Cadrin, S. X. 2009. Stock identification. In *Fish Reproductive Biology: Implications for Assessment and Management*, pp. 230–253. Ed. by T. Jakobsen, M. Fogarty, B. A. Megrey, and E. Moksness. Wiley-Blackwell, Oxford, UK. 440 pp.

Begg GA, Hare JA and Sheehan DD. 1999. The role of life history parameters as indicators of stock structure. *Fish Res*. 43: 141-163. [https://doi.org/10.1016/S0165-7836\(99\)00071-5](https://doi.org/10.1016/S0165-7836(99)00071-5)

Berrien, P., and Sibunka, J. 1999. Distribution patterns of fish eggs in the U.S. NE Continental Shelf Ecosystem, 1977–1987. NOAA Technical Report NMFS, 145. 310 pp.

Brooks EN, Miller TJ, Legault CM, O'Brien L, Clark KJ, Gavaris S, Eeckhaute LV. 2010. Determining length-based calibration factors for cod, haddock and yellowtail flounder. Transboundary Resources Assessment Committee Reference Document 2010/08 (<http://www.mardfo-mpogcca/science/TRAC/trachtml>).

Burnett J, O'Brien L, Mayo RK, Darde JA and Bohan M. 1989. Finfish maturity sampling and classification schemes used during northeast fisheries center bottom trawl surveys, 1963-89. Woods Hole (MA): NOAA Tech Memo. NMFS-F/NEC-76: 14p: [accessed February 2019]. Available from: <http://nefsc.noaa.gov/publications/tm/pdfs/tmfneec2076.pdf>.

Cadrin, S.X., L.A. Kerr, and S. Mariani. 2014. Interdisciplinary evaluation of spatial population structure for definition of fishery management units. In *Stock Identification Methods*, 2nd edn, pp. 535–549. Ed. by S. X. Cadrin, L. A. Kerr, and S. Mariani. Elsevier, San Diego. 566 pp.

Colton, J. B., and Temple, R. F. 1961. The enigma of Georges Bank spawning. *Limnology and Oceanography*, 6: 280–291.

Conover DO, Munch SB and Arnott SA. 2009. Reversal of evolutionary downsizing caused by selective harvest of large fish. *Proc R Soc Lond, Ser B: Biol Sci*. 276: 2015-2020. <http://rspb.royalsocietypublishing.org/content/276/1664/2015.abstract>

Cope JM and Punt AE. 2009. Drawing the lines: resolving fishery management units with simple fisheries data. *Can J Fish Aquat Sci*. 66: 1256-1273. <https://doi.org/10.1139/F09-084>

- Du Pontavice H, Randon M, Lehuta S, Vermard Y and Savina-Rolland M. 2018. Investigating spatial heterogeneity of von Bertalanffy growth parameters to inform the stock structuration of common sole, *Solea solea*, in the Eastern English Channel. *Fish Res.* 207: 28-36.  
<https://doi.org/10.1016/j.fishres.2018.05.009>
- Dean, M.J., W.S. Hoffman, D.R. Zemeckis, and M.P. Armstrong. 2014. Fine-scale diel and gender-based patterns in the behaviour of Atlantic cod (*Gadus morhua*) on a spawning ground in the Western Gulf of Maine. *ICES Journal of Marine Science*, 71(60): 1474-1489.
- Dean M, Elzey S, Hoffman W, Buchan N, Grabowski JH. 2019. The relative importance of sub-populations to the Gulf of Maine stock of Atlantic cod. *ICES J Mar Sci.* doi: 10.1093/icesjms/fsz1083.
- DeCelles, G.R., D. Martins, D.R. Zemeckis, and S.X. Cadrin. 2017. Using fishermen's ecological knowledge to map Atlantic cod spawning grounds on Georges Bank. *ICES Journal of Marine Science*, 74(6): 1587-1601.
- Earll RE. 1880. A report on the history and present condition of the shore cod fisheries at Cape Ann, Mass., together with notes of the natural history and artificial propagation of the species. Report of the Commissioner, U S Commission of Fish and Fisheries for 1878 685-740.  
<https://books.google.com/books?id=0IkYAAAAYAAJ>
- Enberg, K., C. Jorgensen, E.S. Dunlop, M. Heino, and U. Dieckmann. 2009. Implications of fisheries-induced evolution for stock rebuilding and recovery. *Evolutionary Applications*, 2(3): 394-414.
- Friedland KD and Hare JA. 2007. Long-term trends and regime shifts in sea surface temperature on the continental shelf of the northeast United States. *Continental Shelf Research*. 27: 2313-2328. <https://www.sciencedirect.com/science/article/pii/S0278434307001550>
- Friedland KD, Kane J, Hare JA, Lough RG, Fratantoni PS, Fogarty MJ and Nye JA. 2013. Thermal habitat constraints on zooplankton species associated with Atlantic cod (*Gadus morhua*) on the US Northeast Continental Shelf. *Prog Oceanogr.* 116: 1-13.  
<http://www.sciencedirect.com/science/article/pii/S0079661113000530>
- Grabowski, T.B., S.P. Young, L.A. Libungan, A. Steinarsson, and G. Marteinsdottir. 2009. Evidence of phenotypic plasticity and local adaptation in metabolic rates between components of the Icelandic cod (*Gadus morhua* L.) stock. *Environmental Biology of Fishes*, 86: 361-370.
- Grosslein MD. 1973. Mixture of species in subareas 5 and 6. International Commission for the Northwest Atlantic Fisheries, Research Document. Serial No. 2911, 73/9: 1-49.  
<https://www.nafo.int/Library/ICNAF/ICNAF-Documents/ICNAF-Research-Documents/icnaf-research-documents-1973>
- Halliday RG and Pinhorn AT. 1990. The delimitation of fishing areas in the northwest Atlantic. *Journal of Northwest Atlantic Fishery Science*. 10: 1-51.

<http://journal.nafo.int/Volumes/Articles/ID/125/The-Delimitation-of-Fishing-Areas-in-the-Northwest-Atlantic>

Hunt JJ. 1996. Rates of sexual maturation of Atlantic cod in NAFO Division 5Ze and commercial fishery implications. *J Northw Atl Fish Sci.* 18: 61-75.

<https://journal.nafo.int/dnn/Volumes/Articles/ID/219/Rates-of-Sexual-Maturation-of-Atlantic-Cod-in-NAFO-Division-5Ze-and-Commercial-Fishery-Implications>

Jones R and Johnston C. 1977. Growth, reproduction and mortality in gadoid fish species. In: Steele JH, editor. *Fisheries Mathematics*. London, Academic Press. p. 37-62.

Kovach, A.I., T.S. Breton, D.L. Berlinsky, L. Maceda, and I. Wirgin. 2010. Fine-scale spatial and temporal genetic structure of Atlantic cod off the Atlantic coast of the USA. *Marine Ecology Progress Series*, 410: 177-195.

Kuparinen, A. and J. Merilä. 2007. Detecting and managing fisheries-induced evolution. *TRENDS in Ecology and Evolution*, 22(12): 652-659.

Laugen AT, Engelhard GH, Whitlock R, Arlinghaus R, Dankel DJ, Dunlop ES, Eikeset AM, Enberg K, Jorgensen C, Matsumura S, Nussle S, Urbach D, Baulier L, Boukal DS, Ernande B, Johnston FD, Mollet F, Pardoe H, Therkildsen NO, Uusi-Heikkila S, Vainikka A, Heino M, Rijnsdorp AD and Dieckmann U. 2014. Evolutionary impact assessment: accounting for evolutionary consequences of fishing in an ecosystem approach to fisheries management. *Fish Fish.* 15: 65-96. <https://doi.org/10.1016/j.fishres.2015.01.009>

Law R. 2000. Fishing, selection, and phenotypic evolution. *ICES J Mar Sci.* 57: 659-668. <https://doi.org/10.1006/jmsc.2000.0731>

Livingstone R and Dery L. 1976. An observation on the age and length at maturity of cod in the Georges and Browns stocks. International Commission for the Northwest Atlantic Fisheries, Research Document. Serial No. 3826, 76/VI/42: 1-2. <https://www.nafo.int/Library/ICNAF/ICNAF-Documents/ICNAF-Research-Documents/icnaf-research-documents-1976>

McBride RS. 2014a. The continuing role of life history parameters to identify stock structure. In: Cadrin SX, Kerr LA and Mariani S, editors. *Stock identification methods*. 2<sup>nd</sup> ed. San Diego (CA), Academic Press. p. 77-107.

McBride RS. 2014b. Managing a marine stock portfolio: stock identification, structure, and management of 25 fishery species along the Atlantic coast of the United States. *No Amer J Fish Manage.* 34: 710-734. <http://www.tandfonline.com/doi/pdf/10.1080/02755947.2014.902408>

Miller TJ, O'Brien L and Fratantoni PS. 2018. Temporal and environmental variation in growth and maturity and effects on management reference points of Georges Bank Atlantic cod. *Can J Fish Aquat Sci.* <https://doi.org/10.1139/cjfas-2017-0124>



NEFSC (Northeast Fisheries Science Center). 2012. Georges Bank Cod. In: Assessment or Data Updates of 13 Northeast Groundfish Stocks through 2010, Center Reference Document 12-06. Woods Hole, MA, National Marine Fisheries Service. p. 20-95. [accessed March 2019]. Available from: <https://www.nefsc.noaa.gov/publications/crd/crd1206/>.

Northeast Fisheries Science Center, (NEFSC). 2017. Gulf of Maine and Georges Bank Cod. In: Operational assessment of 19 northeast groundfish stocks, Updated through 2016, Center Reference Document 17-17. Woods Hole, MA, National Marine Fisheries Service. 259 p. <https://www.nefsc.noaa.gov/publications/crd/crd1717/>

O'Brien L. 1999. Factors influencing the rate of sexual maturity and the effect on spawning stock for Georges Bank and Gulf of Maine Atlantic cod *Gadus morhua* stocks. J Northw Atl Fish Sci. 25: 179-203. <https://journal.nafo.int/dnn/Volumes/Articles/ID/318/Factors-Influencing-Rate-of-Sexual-Maturity-and-the-Effect-on-Spawning-Stock-for-Georges-Bank-and-Gulf-of-Maine-Atlantic-Cod-emGadus-morhuaem-Stocks>

Penttila J and Dery LM. 1988. Age determination methods for northwest Atlantic species. NOAA Tech Rep NMFS. 72: 135 pp. [Accessed February 2019]. Available from: <http://www.nefsc.noaa.gov/nefsc/publications/classics/penttila1988/>.

Penttila JA and Gifford VM. 1976. Growth and mortality rate for cod from the Georges Bank and Gulf of Maine areas. Inter Comm North Atlantic Fisheries, Res Bull. 12: 29-36. <https://www.nafo.int/Library/ICNAF/ICNAF-Publications/ICNAF-Research-Bulletin>

Pershing AJ, Alexander MA, Hernandez CM, Kerr LA, Le Bris A, Mills KE, Nye JA, Record NR, Scannell HA, Scott JD, Sherwood GD and Thomas AC. 2015. Slow adaptation in the face of rapid warming leads to collapse of the Gulf of Maine cod fishery. Science. 350: 809-812. <http://science.sciencemag.org/content/350/6262/809.full>

Politis PJ, Galbraith JK, Kostovick P and Brown RW. 2014. Northeast Fisheries Science Center Bottom Trawl Survey Protocols for the NOAA Ship Henry B. Bigelow. Northeast Fisheries Science Center Reference Document 14-06. [Accessed February 2019]. Available from: <https://www.nefsc.noaa.gov/publications/crd/crd1406/>.

R Development Core Team. 2014. *R: A Language and Environment for Statistical Computing*. Version 3.4.1. Vienna, Austria: R Foundation for Statistical Computing. [Accessed February 2019]. Available from: <http://www.R-project.org>.

Reid RN, Almeida FP and Zetlin CA. 1999. Essential fish habitat source document: Fishery-independent surveys, data sources, and methods. NOAA Tech Memo. NMFS-NE-122: 39 pp. [Accessed February 2019]. Available from: <https://www.nefsc.noaa.gov/publications/tm/tm122/> .

Ricker, W. E. 1981. Changes in the average size and average age of Pacific salmon. Canadian Journal of Fisheries and Aquatic Sciences, 38: 1636–1656.

Righton DA, Andersen KH, Neat F, Thorsteinsson V, Steingrund P, Svedang H, Michalsen K, Hinrichsen HH, Bendall V, Neuenfeldt S, Wright P, Jonsson P, Huse G, van der Kooij J, Mosegaard H, Hussy K and Metcalfe J. 2010. Thermal niche of Atlantic cod *Gadus morhua*: limits, tolerance and optima. *Mar Ecol Prog Ser.* 420: 1-13. <http://www.int-res.com/articles/feature/m420p001.pdf>

Serchuk FM and Wigley SE. 1992. Assessment and management of the Georges Bank cod fishery: An historical review and evaluation. *J Northw Atl Fish Sci.* 13: 25-52. <http://journal.nafo.int/Volumes/Articles/ID/172/Assessment-and-Management-of-the-Georges-Bank-Cod-Fishery-An-Historical-Review-and-Evaluation>

Serchuk FM and Wood PW. 1979. Review and status of the southern New England/Middle Atlantic cod, *Gadus morhua*, populations. Woods Hole (MA): NMFS-NEFSC, Woods Hole Laboratory Reference Document. 79-37: 77 pp. [accessed February 2019]. Available from: <https://www.nefsc.noaa.gov/publications/series/whlrd/whlrd7937.pdf>.

Serchuk FM, Wood PW, Lewis RR, Penttila J and Brown BE. 1979. Status of the Georges Bank and Gulf of Maine cod stocks, February 1979. Woods Hole (MA): Laboratory Reference Document. 79-10: 32 pp [accessed February 2019]. Available from: <https://www.nefsc.noaa.gov/publications/series/whlrd/whlrd7910.pdf>.

Shapiro Goldberg D, van Rijn I, Belmaker J and Kiflawi M. 2019. Decreases in length at maturation of Mediterranean fishes associated with higher sea temperatures. *ICES Journal of Marine Science.* <https://dx.doi.org/10.1093/icesjms/fsz011>

Sguotti C, Otto S, Frelat R, Langbehn T, Ryberg M, Lindegren M, Durant J, Chr. Stenseth N and Möllmann C. 2019. Catastrophic dynamics limit Atlantic cod recovery. *Proc R Soc B* 286: 20182877. <http://dx.doi.org/10.1098/rspb.2018.2877>

Siceloff, L., and Howell, W. H. 2013. Fine-scale temporal and spatial distributions of Atlantic cod (*Gadus morhua*) on a western Gulf of Maine spawning ground. *Fisheries Research*, 141: 31–43.

Swain, D. P., and Foote, C. J. 1999. Stocks and chameleons: the use of phenotypic variation in stock identification. *Fisheries Research*, 43: 113–128.

Tallack SML. 2009. Regional growth estimates of Atlantic cod, *Gadus morhua*: Applications of the maximum likelihood GROTAG model to tagging data in the Gulf of Maine (USA/Canada) region. *Fish Res.* 99: 137-150. <https://doi.org/10.1016/j.fishres.2009.05.014>

Tallack, S. M. L. 2011. Stock identification applications of conventional tagging data for Atlantic cod in the Gulf of Maine. In *Proceedings from the 2nd International Symposium on Advances in Fish Tagging and Marking Techniques*, pp. 1–15. Ed. by J. McKenzie, B. Parsons, A. C. Seitz, R. K. Kopf, M. Mesa, and Q. Phelps. American Fisheries Society Symposium, 76. 560 pp.

Trippel EA. 1995. Age at maturity as a stress indicator in fisheries. *Bioscience*. 45: 759-771.  
<http://www.jstor.org/discover/10.2307/1312628?uid=3739800&uid=2&uid=4&uid=3739256&uid=56073737343>

Wise JP. 1963. Cod groups in the New England area. *Fish Bull.* 63: 189-203.  
<https://www.st.nmfs.noaa.gov/spo/FishBull/63-1/wise.pdf>

Zemeckis DR, Dean MJ, DeAngelis AI, Van Parijs SM, Hoffman WS, Baumgartner MF, Hatch LT, Cadrin SX and McGuire CH. 2019. Identifying the distribution of Atlantic cod spawning using multiple fixed and glider-mounted acoustic technologies. *ICES Journal of Marine Science*. <https://doi.org/10.1093/icesjms/fsz064>

Zemeckis DR, Liu C, Cowles GW, Dean MJ, Hoffman WS, Martins D and Cadrin SX. 2017. Seasonal movements and connectivity of an Atlantic cod (*Gadus morhua*) spawning component in the western Gulf of Maine. *J Conseil.* 74: 1780–1796.  
<http://dx.doi.org/10.1093/icesjms/fsw190>

Zemeckis DR, Martins D, Kerr LA and Cadrin SX. 2014. Stock identification of Atlantic cod (*Gadus morhua*) in us waters: An interdisciplinary approach. *ICES J Mar Sci.* 71(6): 1490-1506.  
<https://doi.org/10.1093/icesjms/fsu032>

## Supplemental materials

Table S1. Specific dates and number of tows per season (spring, fall) and year (1970-2017) by the Northeast Fisheries Science Center's bottom trawl survey.

| Year | Spring surveys |          |                   |                   | Fall surveys |          |                   |                   |
|------|----------------|----------|-------------------|-------------------|--------------|----------|-------------------|-------------------|
|      | Start date     | End date | Tows <sup>1</sup> | Tows <sup>2</sup> | Start date   | End date | Tows <sup>1</sup> | Tows <sup>2</sup> |
| 1970 | 3/12           | 4/29     | 342               | 288               | 9/5          | 11/20    | 312               | 301               |
| 1971 | 3/9            | 5/5      | 419               | 311               | 9/29         | 11/19    | 334               | 310               |
| 1972 | 3/8            | 4/27     | 366               | 306               | 9/28         | 12/5     | 646               | 646               |
| 1973 | 3/16           | 6/4      | 495               | 495               | 9/26         | 11/19    | 451               | 451               |
| 1974 | 3/13           | 5/4      | 416               | 416               | 9/23         | 11/10    | 379               | 379               |
| 1975 | 3/4            | 5/11     | 305               | 270               | 10/7         | 11/18    | 406               | 406               |
| 1976 | 3/4            | 5/7      | 384               | 384               | 9/28         | 11/22    | 340               | 340               |
| 1977 | 3/19           | 5/19     | 355               | 355               | 9/26         | 12/15    | 419               | 419               |
| 1978 | 3/21           | 5/24     | 397               | 397               | 9/7          | 11/21    | 556               | 556               |
| 1979 | 3/22           | 5/11     | 477               | 477               | 9/13         | 11/18    | 600               | 588               |
| 1980 | 3/18           | 5/7      | 468               | 468               | 9/18         | 11/15    | 420               | 420               |
| 1981 | 3/19           | 5/24     | 395               | 395               | 9/16         | 11/7     | 421               | 416               |
| 1982 | 3/11           | 5/8      | 443               | 420               | 9/14         | 11/11    | 449               | 411               |
| 1983 | 3/7            | 4/30     | 428               | 401               | 9/13         | 11/9     | 476               | 407               |
| 1984 | 3/2            | 4/24     | 407               | 391               | 9/11         | 11/6     | 433               | 337               |
| 1985 | 2/26           | 4/12     | 391               | 371               | 9/10         | 11/15    | 368               | 339               |
| 1986 | 3/4            | 4/27     | 368               | 361               | 9/14         | 11/5     | 364               | 352               |
| 1987 | 3/24           | 4/28     | 349               | 334               | 9/11         | 11/5     | 335               | 316               |
| 1988 | 3/5            | 4/20     | 321               | 314               | 9/13         | 10/27    | 326               | 307               |
| 1989 | 2/28           | 4/13     | 299               | 291               | 9/11         | 11/9     | 342               | 321               |
| 1990 | 3/6            | 4/17     | 322               | 311               | 9/12         | 10/24    | 345               | 332               |
| 1991 | 3/6            | 4/16     | 333               | 324               | 9/10         | 10/24    | 354               | 328               |
| 1992 | 3/3            | 4/16     | 326               | 307               | 9/9          | 10/27    | 353               | 324               |
| 1993 | 3/9            | 4/29     | 329               | 319               | 9/8          | 10/26    | 339               | 325               |
| 1994 | 3/1            | 4/27     | 345               | 326               | 9/7          | 10/27    | 341               | 331               |
| 1995 | 3/7            | 4/27     | 335               | 325               | 9/6          | 10/26    | 360               | 326               |
| 1996 | 3/6            | 4/29     | 350               | 335               | 9/10         | 10/31    | 365               | 320               |
| 1997 | 3/4            | 4/23     | 345               | 327               | 9/4          | 10/30    | 369               | 327               |
| 1998 | 3/3            | 4/20     | 374               | 360               | 9/22         | 11/9     | 374               | 332               |
| 1999 | 3/2            | 4/22     | 329               | 322               | 9/21         | 11/10    | 346               | 339               |

Tows<sup>1</sup>: the total number of tows completed;

Tows<sup>2</sup>: the final number of tows used for plotting abundance after quality control

Table S1 (cont.)

|      |  |      |      |     |     |  |       |       |     |     |
|------|--|------|------|-----|-----|--|-------|-------|-----|-----|
| 2000 |  | 3/16 | 5/3  | 333 | 324 |  | 9/6   | 10/20 | 337 | 329 |
| 2001 |  | 2/28 | 4/30 | 325 | 317 |  | 9/5   | 10/22 | 339 | 330 |
| 2002 |  | 3/6  | 4/25 | 331 | 317 |  | 9/4   | 10/25 | 342 | 321 |
| 2003 |  | 3/6  | 4/27 | 332 | 321 |  | 9/7   | 10/31 | 336 | 322 |
| 2004 |  | 3/3  | 4/21 | 332 | 326 |  | 9/10  | 10/27 | 319 | 311 |
| 2005 |  | 3/4  | 4/21 | 334 | 329 |  | 9/7   | 11/4  | 332 | 322 |
| 2006 |  | 3/8  | 4/19 | 344 | 339 |  | 9/6   | 10/25 | 367 | 357 |
| 2007 |  | 3/8  | 4/27 | 363 | 355 |  | 9/5   | 10/31 | 349 | 342 |
| 2008 |  | 3/7  | 5/3  | 344 | 335 |  | 9/3   | 11/13 | 441 | 341 |
| 2009 |  | 2/27 | 5/9  | 436 | 369 |  | 9/13  | 11/18 | 381 | 328 |
| 2010 |  | 2/28 | 5/2  | 403 | 372 |  | 9/9   | 12/3  | 374 | 334 |
| 2011 |  | 3/3  | 5/10 | 382 | 340 |  | 9/6   | 11/14 | 374 | 326 |
| 2012 |  | 2/29 | 5/3  | 396 | 350 |  | 9/7   | 11/10 | 396 | 363 |
| 2013 |  | 3/5  | 5/8  | 407 | 377 |  | 9/6   | 11/19 | 392 | 365 |
| 2014 |  | 3/31 | 5/31 | 314 | 286 |  | 9/10  | 11/12 | 441 | 359 |
| 2015 |  | 3/14 | 5/6  | 401 | 372 |  | 9/2   | 11/5  | 408 | 370 |
| 2016 |  | 4/8  | 6/6  | 375 | 351 |  | 9/9   | 11/9  | 396 | 378 |
| 2017 |  | 3/7  | 5/12 | 385 | 353 |  | 10/20 | 11/18 | 143 | 130 |

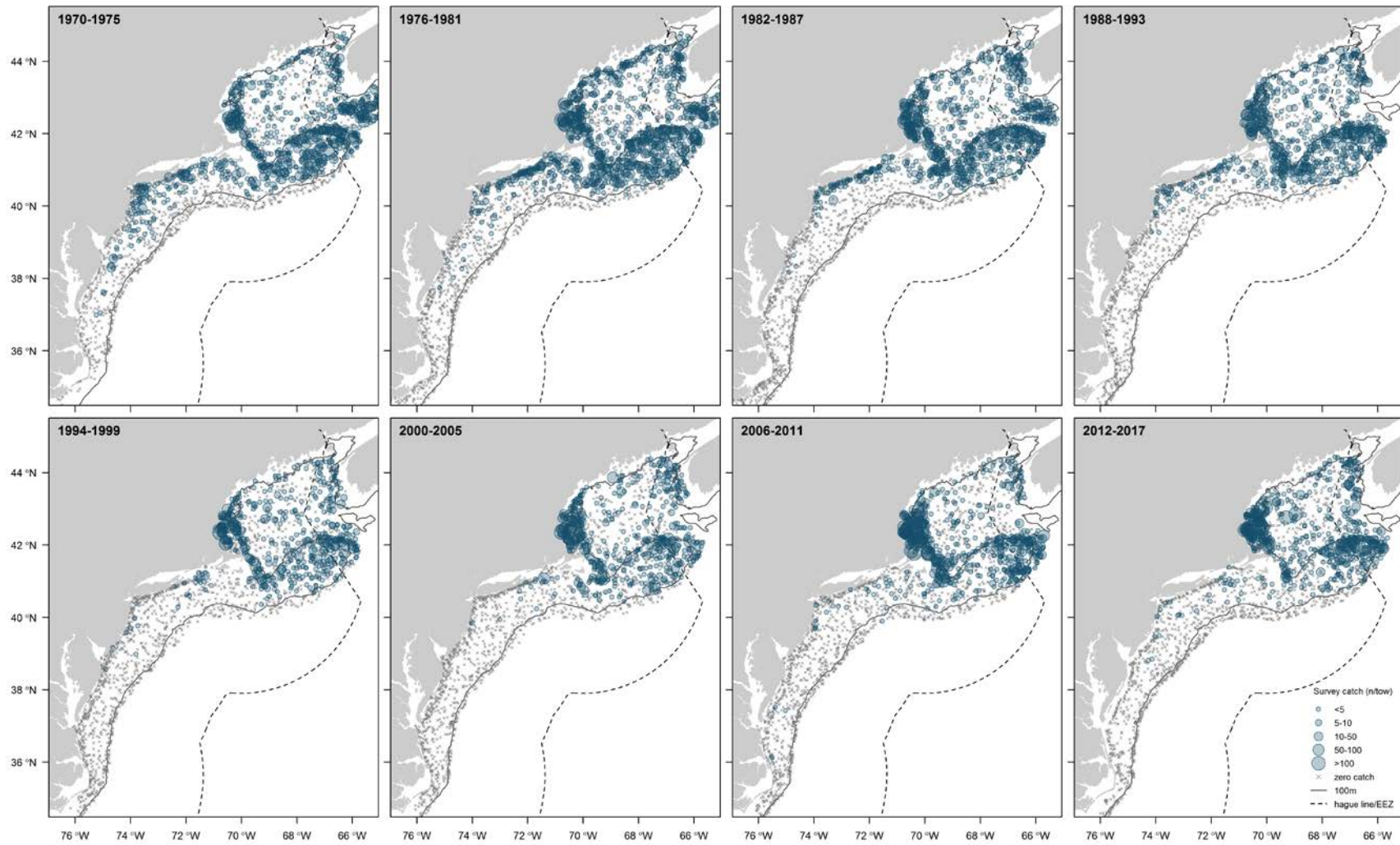


Figure S1a. Spring distribution and abundance (number per tow) of Atlantic cod, *Gadus morhua*, in eight 6-year periods, 1970-2017, of the NOAA bottom trawl survey. The solid isobath = 100 m, and the dashed line delinates the 200 mile exclusive economic zone. Biomass values are presented in Fig. 3.



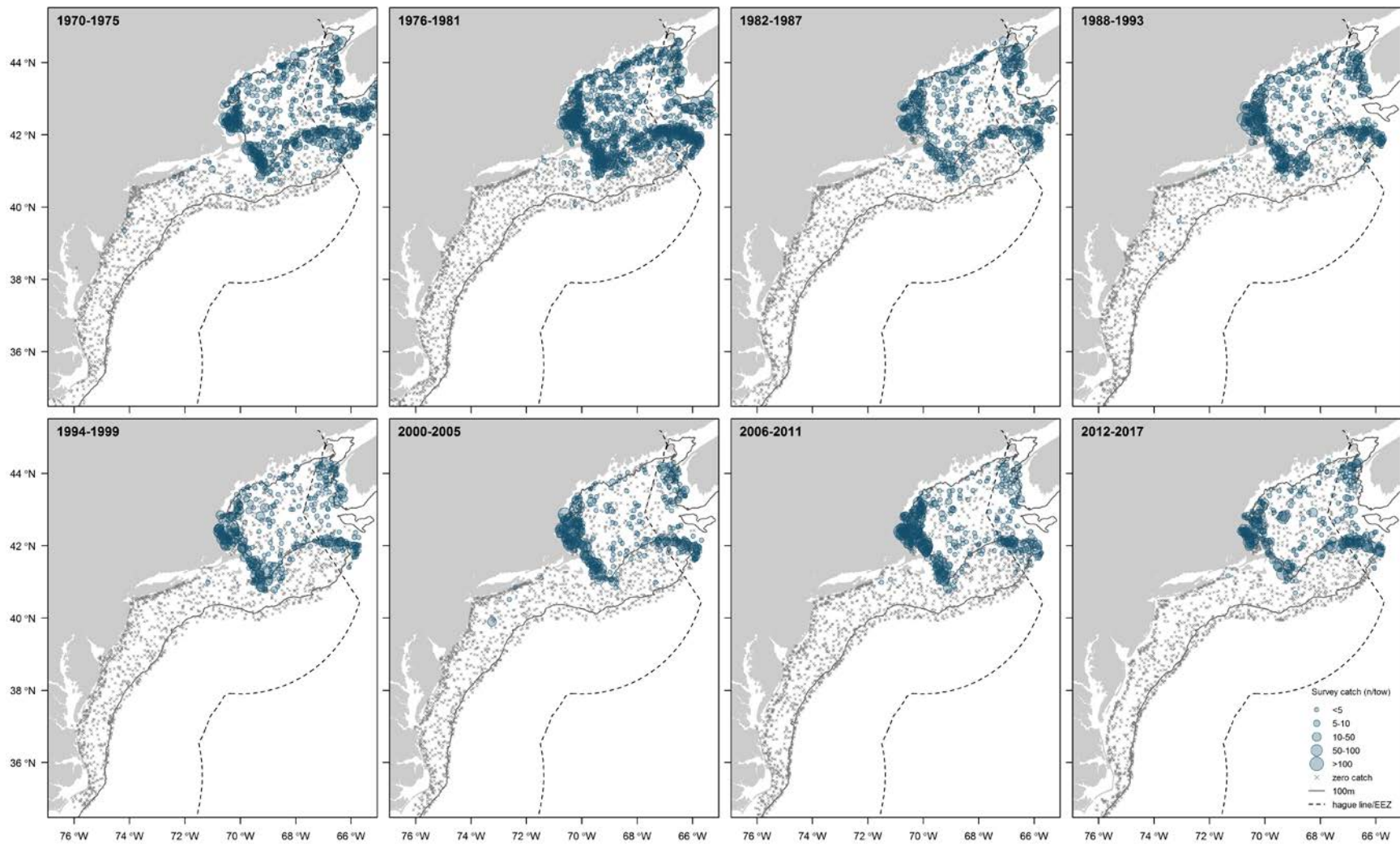


Figure S1b. Fall distribution and abundance (number per tow) of Atlantic cod, *Gadus morhua*, in eight 6-year periods, 1970-2017, of the NOAA bottom trawl survey. The solid isobath = 100 m, and the dashed line delineates the 200 mile exclusive economic zone. Biomass values are presented in Fig. 3.

Female, age-2 cod, collected in spring.

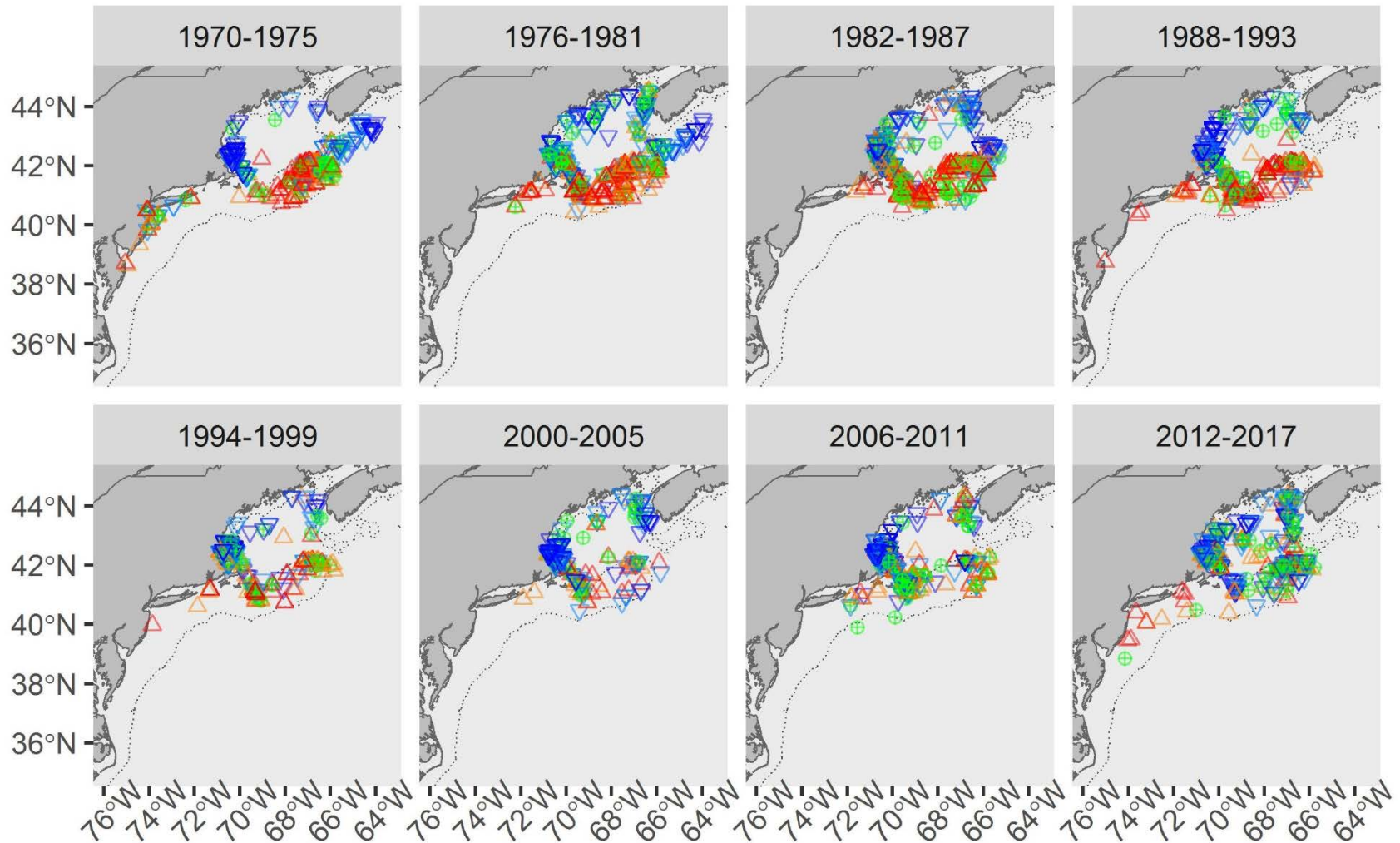


Figure S2a. Spring distribution of female age-2 Atlantic cod, *Gadus morhua*, females (top) and males (bottom) in eight 6-year periods, 1970-2017. Color coding is explained in Figs. 1, 3. The dotted isobath = 100 m.



Male, age-2 cod, collected in spring.

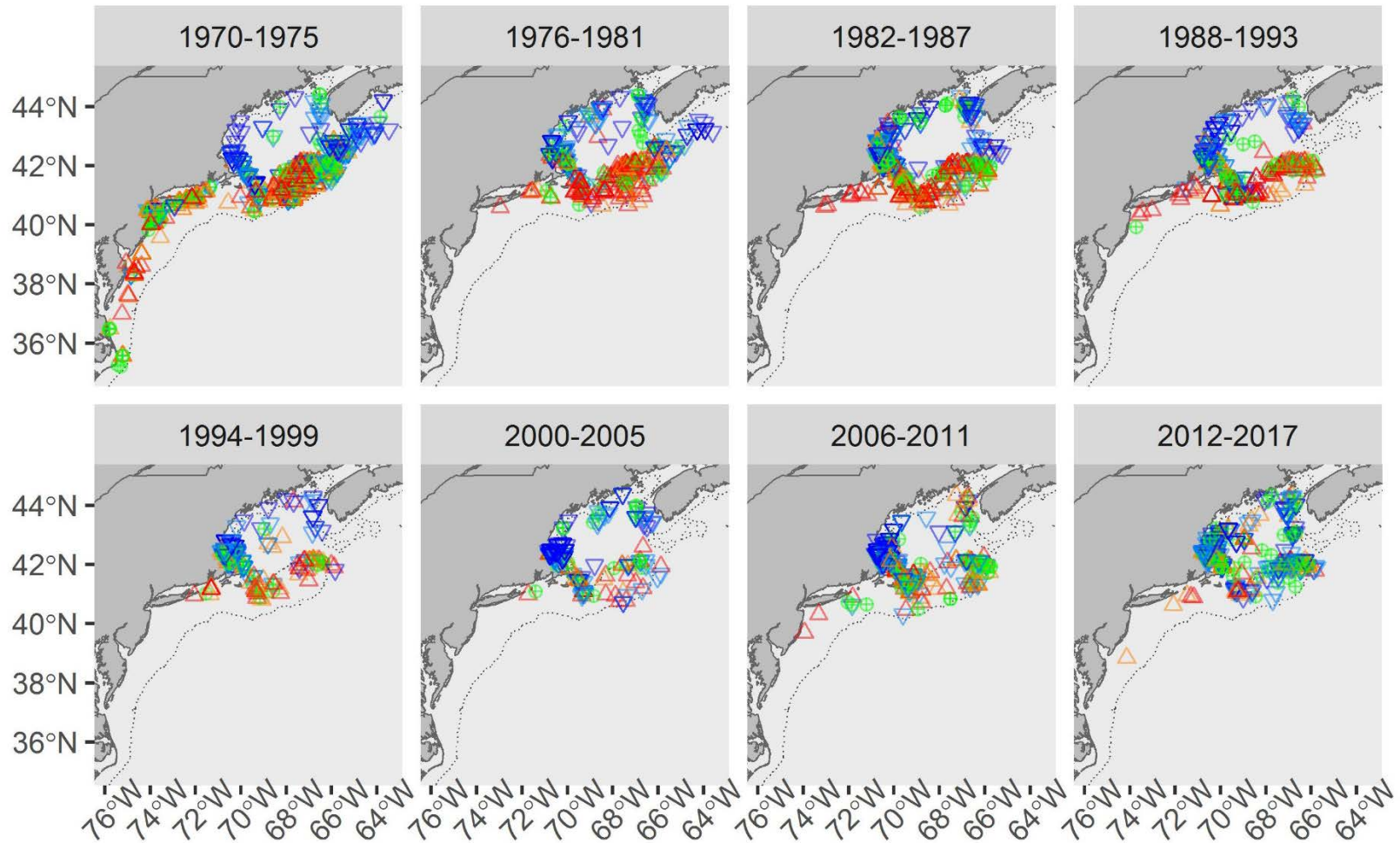


Figure S2b. Spring distribution of male age-2 Atlantic cod, *Gadus morhua*, females (top) and males (bottom) in eight 6-year periods, 1970-2017. Color coding is explained in Figs. 1, 3. The dotted isobath = 100 m.

Female, age-2 cod, collected in fall.

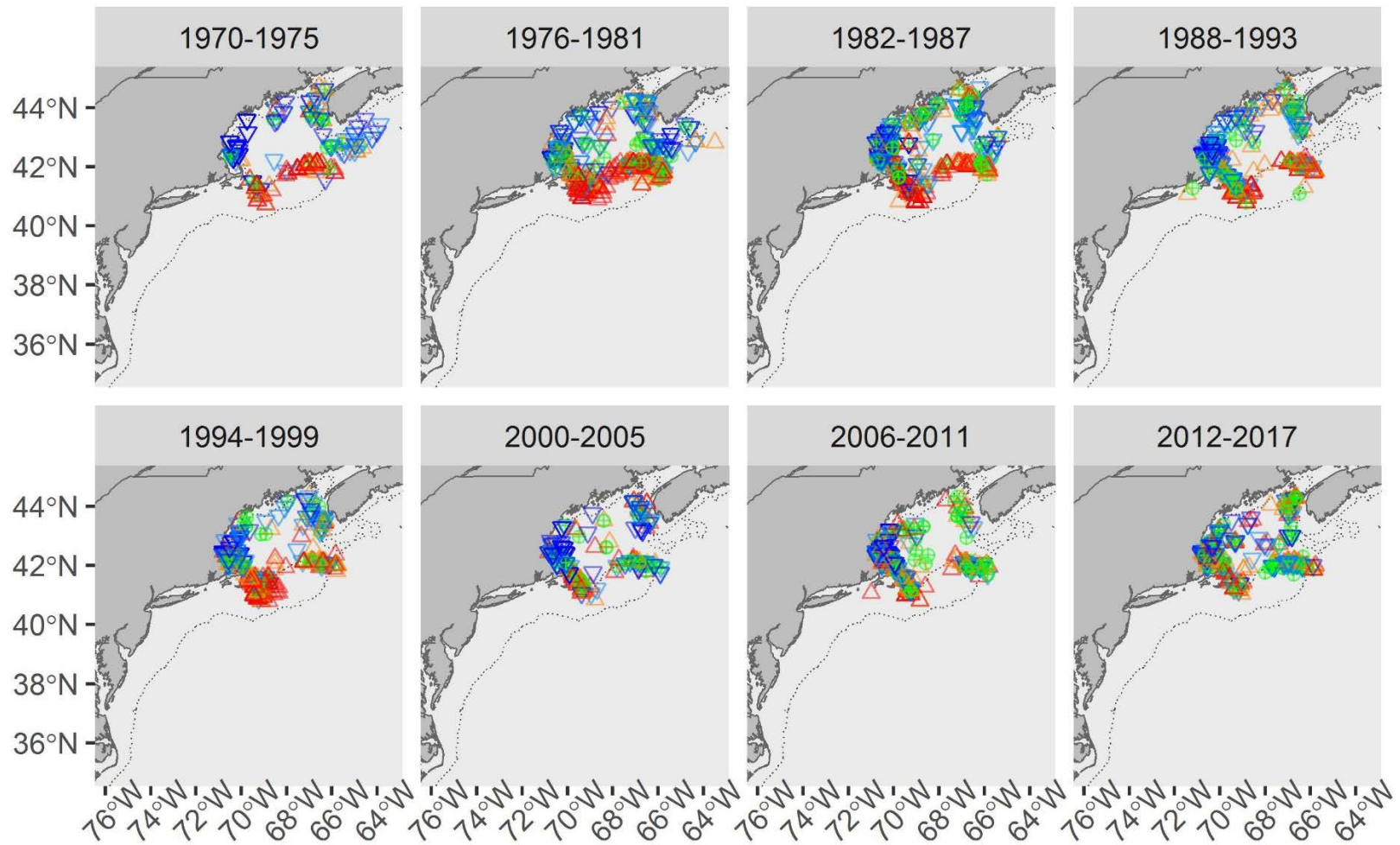


Figure S3a. Fall distribution of female age-2 Atlantic cod, *Gadus morhua*, females (top) and males (bottom) grouped in eight 6-year periods, 1970-2017. Color coding is explained in Figs. 1, 3. The dotted isobath = 100 m.

Male, age-2 cod, collected in fall.

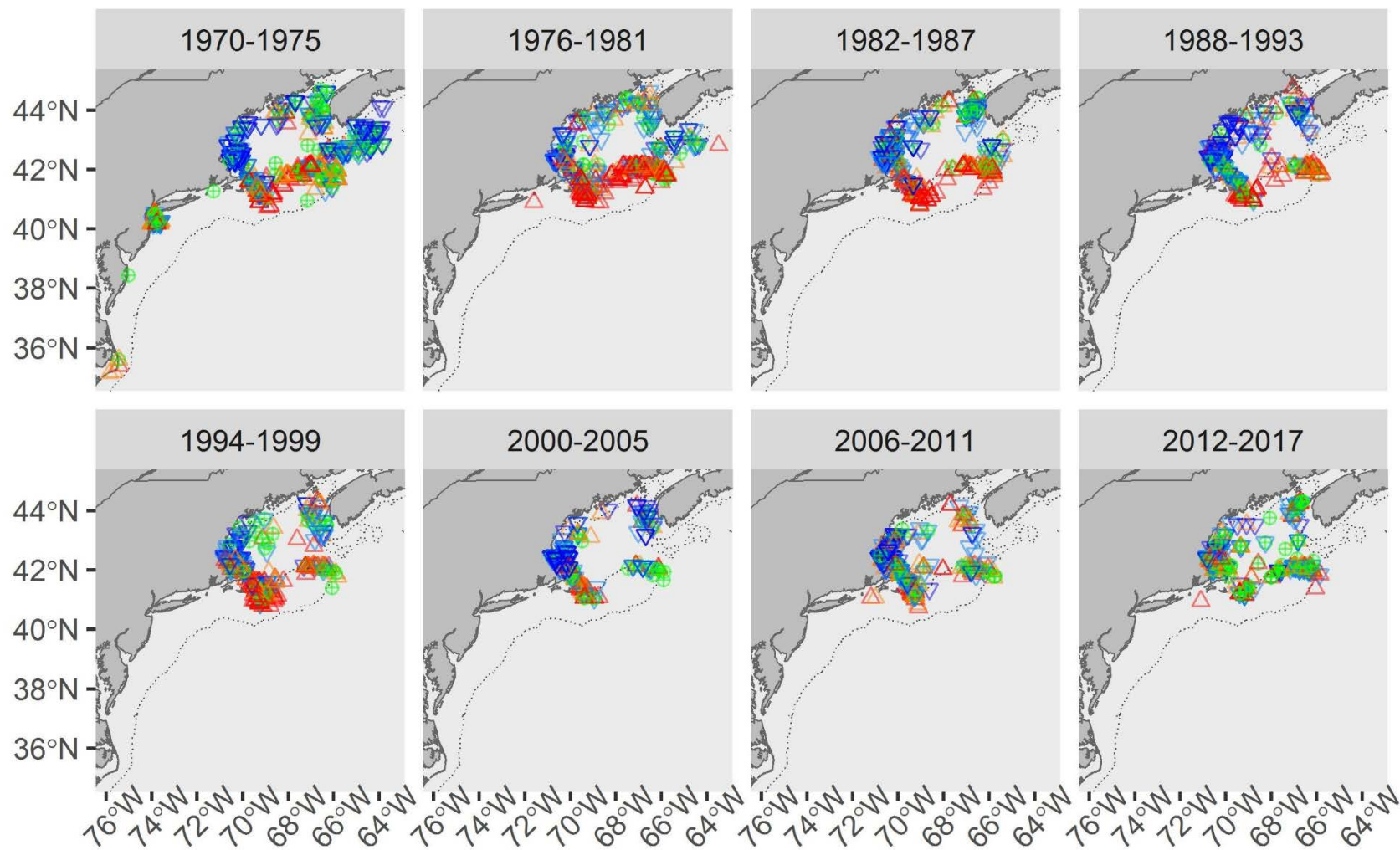


Figure S3b. Fall distribution of male age-2 Atlantic cod, *Gadus morhua*, females (top) and males (bottom) grouped in eight 6-year periods, 1970-2017. Color coding is explained in Figs. 1, 3. The dotted isobath = 100 m.

## Chapter 6. NATURAL MARKERS

Subgroup: Kerr, L, DeCelles, G., Puncher, G., Cadrin, S., McBride, R.

Reviewers: Dean, M. Sherwood, G., Whitener, Z.

12. 19.19

### Abstract

Natural markers are naturally-induced characteristics that can be used to identify members of a population, stock, or more discrete grouping of organisms. A variety of different phenotypic characters have been used to identify fish populations and to discriminate the origin of fish through mixed stock analysis. Elemental and isotopic fingerprints, genetic markers, growth patterns and shape recorded in otoliths, and parasites are all examples of natural markers with demonstrated success in identifying and tracking populations. The natural markers applied to Atlantic cod to date include otolith characteristics (chemistry, shape, and structure), tissue characteristics (stable isotopes concentrations and fatty acid profiles), body characteristics (color type, morphometrics, and meristics), and other features, such as parasites. Natural markers (otolith chemistry, structure and morphometrics) support winter and spring spawners as unique groups in the Gulf of Maine. This finding is supported by genetics findings. Morphometric results also suggest that cod on eastern and western Georges Bank may comprise unique groups. These results are in broad agreement with genetic analyses, tagging studies, and Fishermen's Ecological Knowledge. Parasite infestation rate suggests separation between the northern Gulf of Maine, central Gulf, Georges Bank, and Southern New England cod.

### Introduction

Natural markers are naturally-induced characteristics that can be used to identify members of a population, stock, or more discrete grouping of organisms. In this section, we will describe phenotypic traits, observable characteristics of fish, which have been identified as useful natural markers of stock identity. Although phenotype is distinct from genotype (genetic markers for stock identification are addressed in Chapter 3), phenotypic differences between groups may reflect genetic differences, environmental differences, or some combination of both (Swain et al. 2005, Heino 2014). In general, even genetically similar fish that reside in different environments are expected to exhibit physical dissimilarities, due to the influence of the unique conditions to which they are exposed (Swain et al. 2005). In some instances, natural markers can reveal subtle population structure that may not be detected by genetic applications alone (e.g., contingent structure, Kerr et al. 2010). For some multi-disciplinary investigations of population structure, natural markers have been found to be the most informative basis for stock identification (e.g., horse mackerel *Trachurus trachurus*, Abaunza et al. 2008). The main advantage of phenotypic characteristics is that they reflect both the influence of natural selection and the environment. Although in many instances it can be challenging to distinguish if differences have a genetic basis or have been environmentally induced (Swain et al. 2005). Information gathered from phenotypic markers are often combined with genetic data and movement information for more robust inference regarding stock structure.



A variety of different phenotypic characters have been used to identify fish populations and to discriminate the origin of fish through mixed stock analysis. The challenge is identifying a marker, or group of markers, that is sufficiently distinct that it will allow clear identification of the group of interest. Among fishes, elemental and isotopic fingerprints, genetic markers, growth patterns and shape recorded in otoliths, and parasites are all examples of natural markers with demonstrated success in identifying and tracking populations or finer-scale groups (Cadurin et al. 2014). Natural markers can be incredibly valuable to stock identification due to their potential for simultaneous appearance among members of a group or population.

In this Chapter, we review the best available science on the application of natural markers to the study of Atlantic cod stock structure in the northwest Atlantic (NAFO Divisions 5 and 6 and interactions with 4X). The natural markers applied to cod include otolith characteristics (chemistry, shape, and structure), tissue characteristics (stable isotopes concentrations and fatty acid profiles), body characteristics (color type, morphometrics, and meristics), and other features, such as parasites.

## **Review of natural markers application to Atlantic cod**

### *Otolith Characteristics: Chemistry, Shape, and Structure*

Otoliths are calcified structures within the inner ear of fish which grow throughout a lifetime by accumulating calcium carbonate, preserving a detailed record of the chemistry of the environment experienced by an individual fish and its growth history over time (Campana 1999; Kerr and Campana 2014). Otolith characteristics, including chemical composition, shape, and macro- and microstructure, have been identified as informative natural markers relevant to understanding population structure and the natal origin of fish.

### **Otolith Chemistry**

There is a considerable body of work that has established the utility of otolith chemistry as a useful natural marker of fish stock structure and tracer of fine-scale habitat use of fish indicative of alternative life history types (Campana 2005; Elsdon et al. 2008; Kerr and Campana 2014). This technique depends on geographic variation in water chemistry (e.g., coastal vs. offshore gradients) or other factors (e.g., temperature, salinity) that influence the chemistry of otoliths such that fish that inhabit different environments exhibit differences in their otolith chemical composition (Kerr and Campana 2014). In addition to environmental differences, the chemical composition of fish otoliths can also be influenced by fish physiology (Sturrock et al. 2015) and genetics (Clarke et al. 2011). Applications of this approach often focus on analysis of otolith cores composed of the first few months up to a year of otolith growth, which provide insight on natal origin of fish. However, whole otolith analysis is used as well to demonstrate lifetime differences in habitat use. Of the three pairs of fish otoliths, the sagitta, lapillus, asteriscus, the sagitta is most frequently used due to its size, with limited examples of applications to the lapillus and asteriscus.

There are several examples of past applications of otolith chemistry to cod in US and Canadian waters, as well as ongoing work that is relevant to understanding population structure of cod in

US waters. Campana et al. (1994) used otolith chemistry to discriminate Atlantic cod collected at five spawning grounds in the northwest Atlantic (Chéticamp [Cape Breton, Canada], Fundyrip [Bay of Fundy, Canada], Georges Bank, Newfoundland and Iceland). The study found significant differences among concentrations of 14 isotopes across spawning sites. However, between site differences were small resulting in low classification accuracy between spawning sites based on discriminant analysis (30% jackknife accuracy). Campana and Gagne (1995) expanded on this approach, evaluating Atlantic cod otoliths from seven spawning grounds (the five previously mentioned and the Gulf of St. Lawrence and Eastern Scotian Shelf) for 34 isotopes to test for differences in chemical composition. The highest level of discrimination was based on sagittal otoliths between Scotian Shelf and Gulf of St. Lawrence fish (i.e., 90 to 98% accuracy). In addition, discriminant analysis based on a subset of isotopes analyzed in lapillar otoliths also revealed relatively high classification success (average 83% accuracy) with the highest error rate associated with the discrimination of the Georges Bank and adjacent Fundyrip samples, which may suggest connectivity between these areas or reflect similar chemical signatures across adjacent areas. These early applications of otolith chemistry to cod in the northwest Atlantic demonstrate that this technique has the capacity for accurate discrimination of cod spawning populations over a large geographical range.

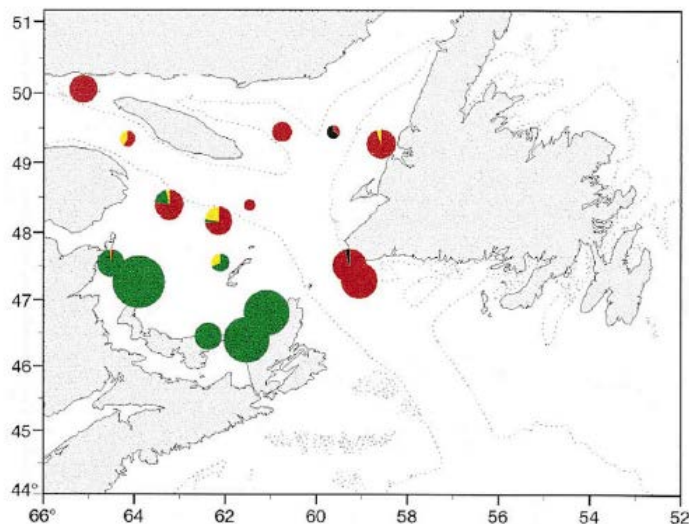


Figure 1. Campana et al. (2000) mixed stock analysis of cod in Canadian waters. Spawning aggregations each had a unique elemental fingerprint. Mixed stock analysis in summer (feeding) and winter (overwintering).

Campana et al. (1999) conducted a mixed stock analysis on cod overwintering in the Gulf of St. Lawrence using otolith elemental chemistry. Four populations were identified within this region, including: 1) northern Gulf, 2) southern Gulf, 3) southern Newfoundland, and 4) eastern Scotian Shelf. The authors used the stock composition analysis of the individual trawl samples to develop maps of population specific abundance and distribution during winter. Campana et al. (2000) demonstrated the utility of whole otolith elemental analysis of Atlantic cod for stock identification in Canadian waters (Figure 1). Spawning aggregations each had a unique elemental fingerprint and mixed stock analysis demonstrated the application of this approach in determining stock composition of cod both on feeding (summer) and overwintering grounds,

when aggregations of mixed stocks occur. Although these studies were restricted to application within Canadian waters, this study demonstrates the utility of this stock identification method for mixed stock analysis with high classification accuracy.

Recent work by Kerr et al. (2018), applied otolith microchemistry to discriminate winter and spring spawning cod in the Gulf of Maine (Massachusetts and Ipswich Bays; sampling years 2012-2016;  $n = 252$ ; Figure 2). Significant differences in the elemental fingerprint of cod otoliths (age one and whole otolith) were evident between the two spawning groups (Figure 3), supporting a previous genetic study that identified the two groups as temporally distinct spawning populations (Kovach et al. 2010). There were also significant differences, albeit smaller in magnitude, in otolith chemistry based on capture location. Stepwise discriminate function analysis with jackknife prediction was used to classify fish based on age one otolith chemistry to spawning time (winter and spring), location (Ipswich and Massachusetts Bay), and the interaction of these factors. Classification success of Atlantic cod to spawning time (winter and spring) was relatively high at 74%. However, classification rates to capture location (48%) and to spawning times within each location (46%) was low. This study illustrates the utility of otolith chemistry for discrimination of winter and spring spawners in the inshore Gulf of Maine. Application of this technique to samples representative of the fishery (collected 2015-2016) revealed the composition of fish was dominated by winter spawners (ranging from 55 to 65% across years; Figure 4).

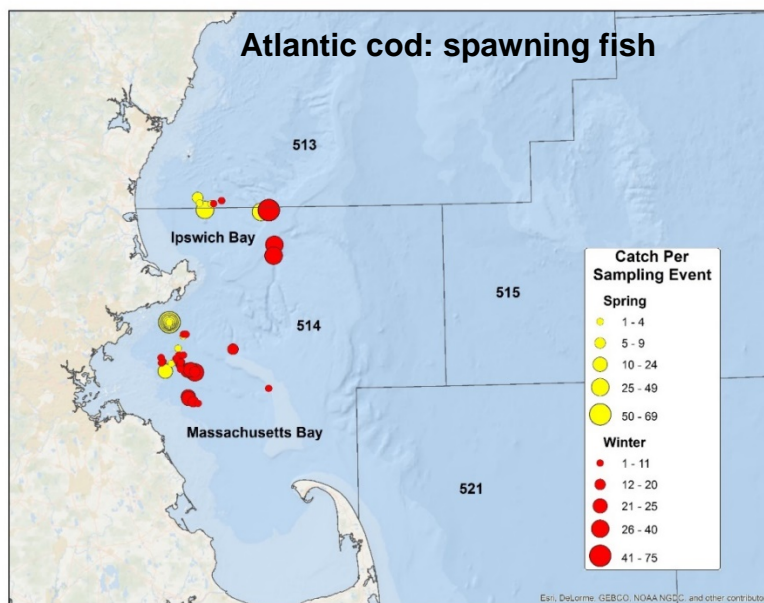


Figure 2. Map illustrating sampling locations and timing of spawning cod samples by season for this project. Each bubble represents numbers of fish sampled per discrete sampling event (date and location of capture). Statistical areas are denoted as well (Kerr et al. 2018)

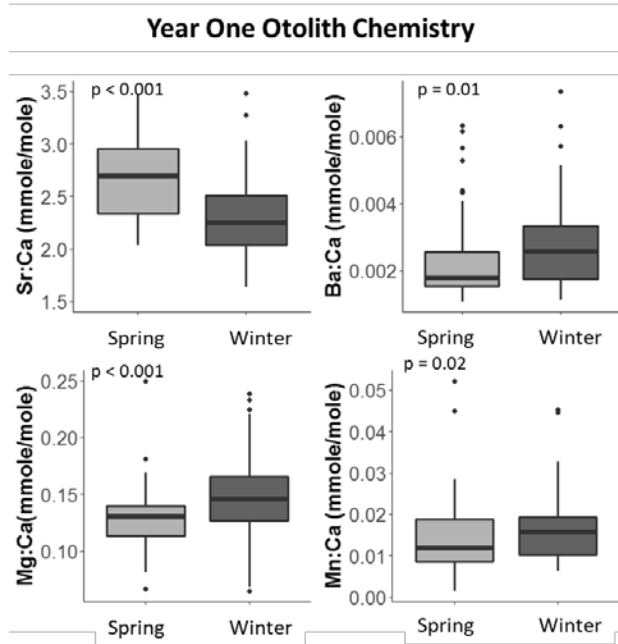


Figure 3. Elemental ratios from year one region of Atlantic cod otoliths from winter and spring spawning populations in the Gulf of Maine (Kerr et al. 2018).

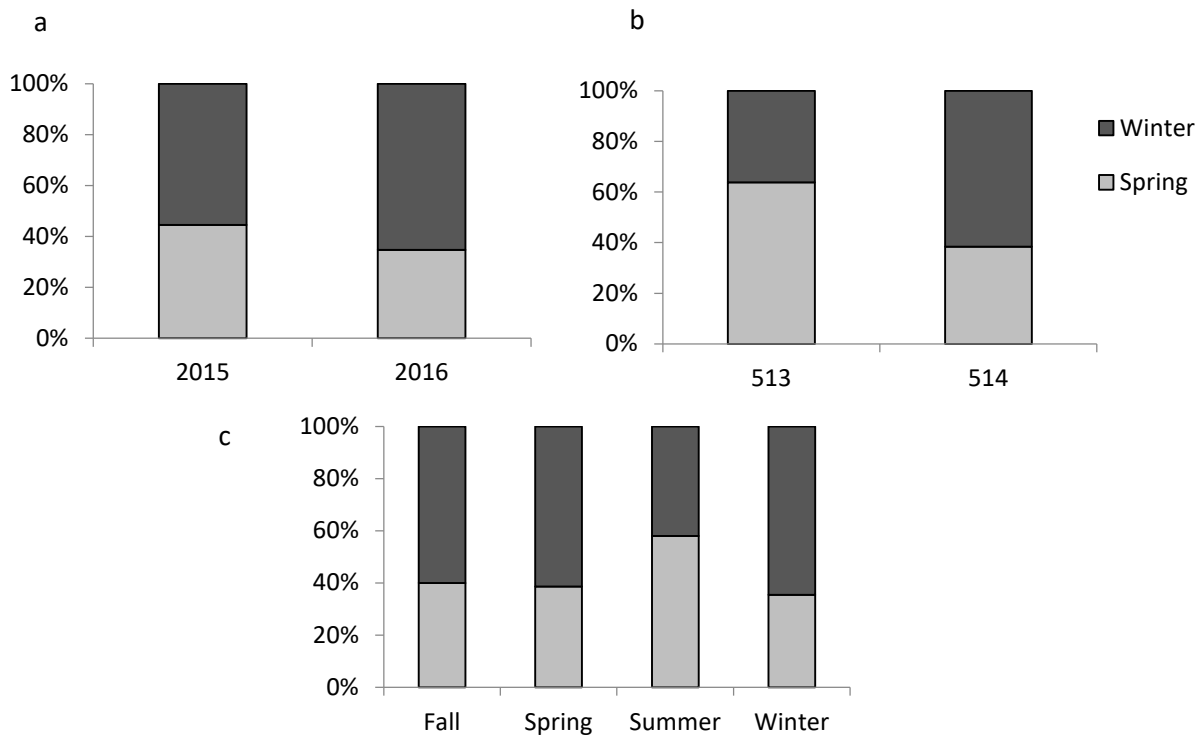


Figure 4. Mixed stock composition of fishery collected Atlantic cod a) over time (2015-2016), b) across statistical area (513 and 514), c) and season using random forest classification approach (Kerr et al. 2018).



## Otolith Shape

Otolith shape has been shown to have great utility in stock discrimination and has been applied to other cod stocks, informing separation of eastern and western Baltic cod (Hüssey et al. 2016) and Norwegian coastal cod and Northeast Arctic cod (Stransky et al. 2008). Otolith shape is known to be influenced by a combination of genetic and environmental factors with fish of different origin and life histories exhibiting shape variation that can be used to discriminate between stocks (Vignon and Morat 2010).

Campana and Casselman (1993) applied otolith shape analysis to classify cod populations in the northwest Atlantic. They applied the technique to otoliths from fish in spawning condition collected at 19 sites in US (Gulf of Maine and Georges Bank) and Canadian waters, as well as Iceland. They found that classification accuracy was wide ranging. In general, samples from the Gulf of Maine region were accurately classified to region (61-80% correct), but there was poor classification success for other regions: 1) Eastern Scotian Shelf, 2) St. Lawrence, 3) Newfoundland, and 4) Iceland (Figure 5). It is important to note that this was an early application of this approach and technical developments have occurred since this implementation (Stransky 2014). Thus, although there are few current applications to cod in the northwest Atlantic, this technique has a strong potential for utility in cod stock discrimination based on successful application in other regions.

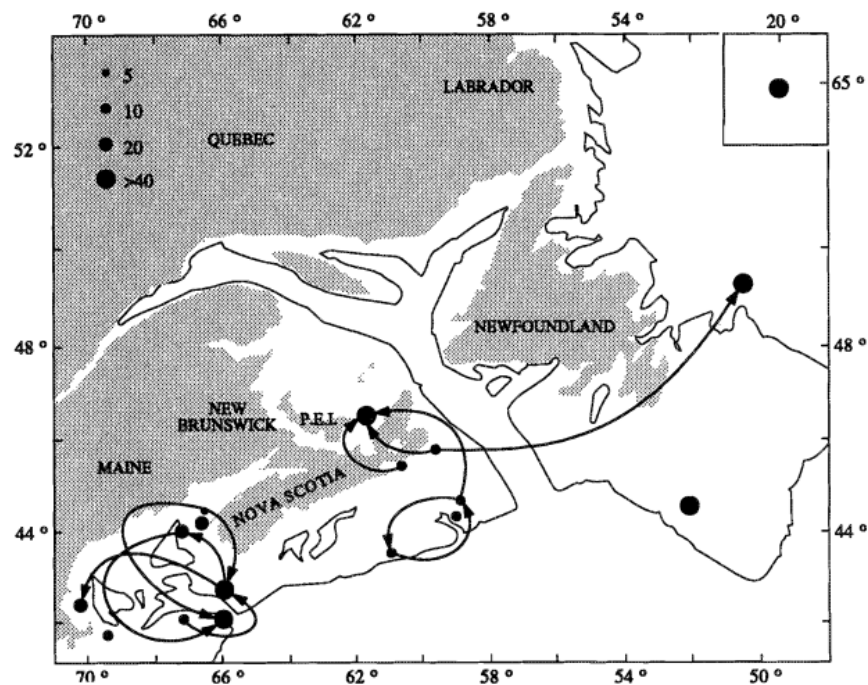


Figure 5. Summary map from Campana and Casselman (1993) depicting the classification patterns resulting from centroid-based discriminant analysis of all three left-hand otolith types combined. The expanding symbols represent the percentage of fish entered into the discriminant functions which were correctly classified. Vectors connecting samples represent misclassification errors which exceeded 15%. None of the samples were mistakenly assigned to a single sample at a rate of more than 20%. Misclassification errors of less than 15% are not shown.

## Otolith Structure

Otoliths “growth signatures” have been established as a powerful tool for stock identification (Brophy 2014). The relative growth of otolith annuli is known to be related to growth of the fish and changes in fish and otolith growth are expected to occur ontogenetically, but otolith growth will also vary spatially and temporally in response to different oceanic conditions, as well as genetic differences that may influence metabolism (Brophy 2014). Annual, seasonal, and daily growth patterns have been used to distinguish groups of fish with different growth histories (Brophy 2014). Otolith structure, specifically the size of year one otolith growth, has been successfully applied to discriminate Norwegian coastal cod from Northeast Arctic cod (Berg et al. 2005).

An analysis of otoliths from spring and winter spawning cod in the Gulf of Maine has identified distinct early growth patterns between the two spawning populations (Dean et al. 2019, Figure 6). Although the diameter of the first annulus was the primary discriminating feature, the age of fish upon capture was also important, suggesting a difference in mortality rates between groups. Using a logistic regression model fit to training data (n=577) and evaluated through cross-validation, individuals were correctly classified with 81% accuracy and the overall sub-population mixture was predicted within 1%. Applying the model to a broader population dataset (n=1642) revealed that spring-spawned cod are more prevalent within closed fishing areas and therefore experience a lower mortality rate. However, despite dominating older age classes and comprising a relatively large fraction of the spawning stock, these spring cod currently contribute little to annual recruitment. Significant differences in growth and mortality were found between the two groups, where winter-spawners grow and mature at a faster rate, but spring-spawners reach a larger maximum size. These apparent differences in vital population rates (i.e., mortality, productivity, growth, maturity) have important consequences for assessment models and management measures that assume homogeneity across the stock.

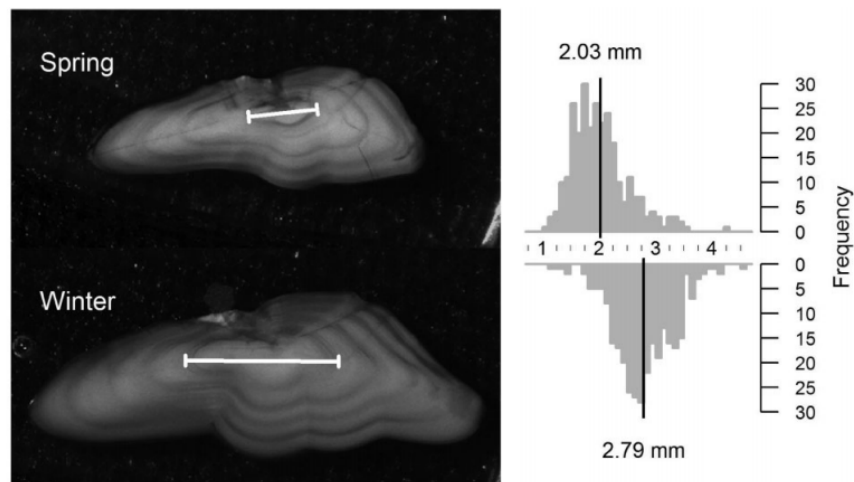


Figure 6. [Left] Otolith cross-sections from two age 4 cod, both captured in spawning condition. The one at top was captured in May, while the one at bottom was captured in December. The diameter of the first (A1) annulus is identified. [Right] Histograms of otolith A1 diameter (mm)

from the training dataset, for spawning cod captured in spring (top, n = 278) and winter (bottom, n = 301); mean values are identified by the dark vertical line (Dean et al. 2019).

In addition, ongoing work by Kerr et al. 2018 identified significant differences in otolith growth of winter and spring spawning cod from the Gulf of Maine across ages one to five, with the exception of age three. The largest differences in growth were evident in the width of the age one annulus between winter and spring spawning cod. Differences in age one otolith growth are related to the spawning phenology of cod (i.e., different starting points in life) and how the first annulus of an otolith is defined (i.e., one opaque and translucent zone is counted as a year). We also expect that winter and spring spawners experience very different early growth conditions due to starting life at different time periods in seasonally variable Gulf of Maine waters. Applying a discriminant function analysis classification approach with jackknife prediction to otolith growth information, we were able to assign winter and spring spawners to their known spawning group with reasonable classification accuracy using increment width across all ages (~66%). Considerably higher classification accuracy was achieved when only relying on age one otolith increment width (78%). Classification accuracy of fish to location (54%) and spawning time at location (44%) based on age one otolith growth was considerably lower.

### *Body Characteristics: Meristics, Morphometrics, and Color Morphs*

#### **Color Morph**

Gosse and Wroblewski (2004) noted that color morphs of cod are common in the waters of Labrador and Newfoundland, and that cod in Gilbert Bay, Labrador which feed primarily on invertebrates commonly exhibit a golden-brown color, and are colloquially known as “the golden cod of Labrador”. These golden-brown cod were held in a net pen for three months and fed a fish based diet. The color of the cod changed over the holding period, as the experimental fish lost much of their golden-brown pigmentation, and the ventral surface became lighter, as the fish adopted a more “typical” countershading pattern (Figure 7A). Similarly, a local morph of “red cod” were also held for three months and fed a fish based diet. Over time, the red pigment on the cod gradually transitioned to a brownish color, and the ventral surface of the cod became lighter (Figure 7B). Taken together, these findings suggest that coloration in cod is strongly influenced by diet, and is not a stable marker. Nevertheless, Wroblewski et al. (2005) suggest that color can be used as part of interdisciplinary stock composition analysis to aid in distinguishing resident and migratory cod groups in mixed fishery catches.

Sherwood and Grabowski (2010) reported that “red cod” are commonly observed near Cashes Ledge (Ammen Rock), and the presence of red cod in the Gulf of Maine was also noted by Bigelow and Schroeder (1953) and confirmed by Conroy (2016). Sherwood and Grabowski sampled cod from Cashes Ledge over a three year period (2007-2009) and investigated the growth, diet, morphometrics and isotope signatures of these fish. The authors noted an abrupt cutoff in the color (red to green ratio; RGR) of cod caught around Cashes Ledge, with higher red to green ratios for cod captured in shallow waters near Ammen Rock. Based on von Bertalanffy growth curves, red cod appear to grow slower, and reach smaller asymptotic sizes than olive cod. The diets of these two color morphs differed, which was reflected in their  $\delta^{13}\text{C}$  and  $\delta^{15}\text{N}$  ratios. Red cod primarily fed on lobsters, crabs, and benthic fish, while the olive cod primarily consumed pelagic shrimp. The body shape of red and olive cod also differed, with red cod

exhibiting shorter snouts, deeper bodies, and more slender tails. Using body shape, cod could be classified back to their color type with 84% accuracy. Based on the observed differences in growth, morphometry, habitat, and diet, red cod may exhibit a unique life history strategy in the Gulf of Maine (i.e., more sedentary and shallow-living). Indeed, follow up work (Conroy et al. 2017) showed that red cod at Cashes Ledge inhabit shallower depths and exhibit more sedentary behavior, as indicated by acoustic telemetry. However, further work is needed to determine whether these red cod represent a genetic ecotype that is distinct from olive cod, or if it is a conditional life history strategy. A common garden experiment would help to elucidate this problem.

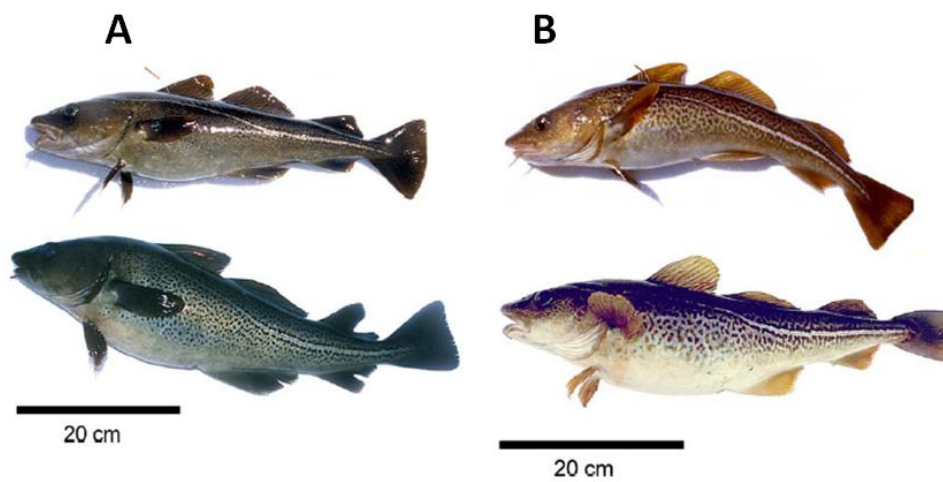


Figure 7. Color changes observed in cod from Gilbert Bay, Labrador, observed over a 12 week holding period. Figure 7A shows the original coloration of the cod, at the start of the holding period. These cod are colloquially referred to as ‘brown cod’, as indicated by the brownish pigment on the fins and ventral side of the fish. By the end of the holding period, the brown coloration had largely disappeared from the cod, and the ventral surface had lightened (bottom picture). Figure 7B shows the original (top) and final (bottom) coloration of the “red cod” over the 12 week holding period. Note the loss of the red pigment, and the lightening of the ventral surface that occurred during the experiment. Figure taken from Gosse and Wroblewski (2004).

## Meristics

Meristic characters are features of fish that can be counted. External body features such as fin rays, gill rakers, and scales, and internal features such as vertebrae, pterygiophores and branchiostegal rays can be used in meristic analyses (Waldman 2005). Values for meristic characters result from interactions between environmental and genetic influences. The formation of meristic characters is influenced by temperature, pH, salinity, oxygen levels, food availability, and the growth of an individual (Barlow 1961). Meristic values for a body feature are usually determined during early life history and can be useful for stock identification, indicating that early development occurred under different conditions or in separate areas (Chase 2014). There is generally an inverse relationship between water temperature and the counts of meristic features, known as Jordan’s Rule (Chase 2014). Meristic characters are inexpensive to obtain, and relatively easy to analyze, and as a result, have been used in stock identification research for

over a century. Waldman (2005) and Chase (2014) provide an excellent overview of case studies where meristic characters have been used to investigate stock structure.

Meristic characters, especially vertebrae and fin ray counts, have been applied extensively to investigate Atlantic cod stocks in Canadian and European waters. In a multidisciplinary study, Martin (1953) employed a combination of meristics, tagging, life history data and parasites to examine the stock structure of cod off Nova Scotia and the Gulf of St. Lawrence. Mackenzie and Smith (1955) also used vertebral counts to examine the stock structure of cod in Canadian waters, and documented at least four populations in the Gulf of St. Lawrence, and seven populations on the Scotian Shelf. They also used vertebral counts to study the seasonal migrations of cod on the Scotian Shelf. Over three decades, Templeman (1981) analyzed the vertebral counts of nearly 45,000 cod ranging from the Scotian Shelf to western Greenland, and found geographic variation related to temperature and latitude, with higher vertebral counts being associated more northern samples. Pepin and Carr (1993) used a combination of meristics, morphometrics and genetics to investigate the stock identity of cod on the Grand Banks, and found low reclassification rates (<50%), suggesting a single cod stock inhabited the study area. Swain et al. (2001) successfully used vertebral counts to examine the stock composition of cod harvested in the Laurentian Channel winter fishery (Figure 8). In a common garden experiment, Loken and Pedersen (1996) demonstrated that vertebral number in Norwegian cod is determined both by genetics and temperature.

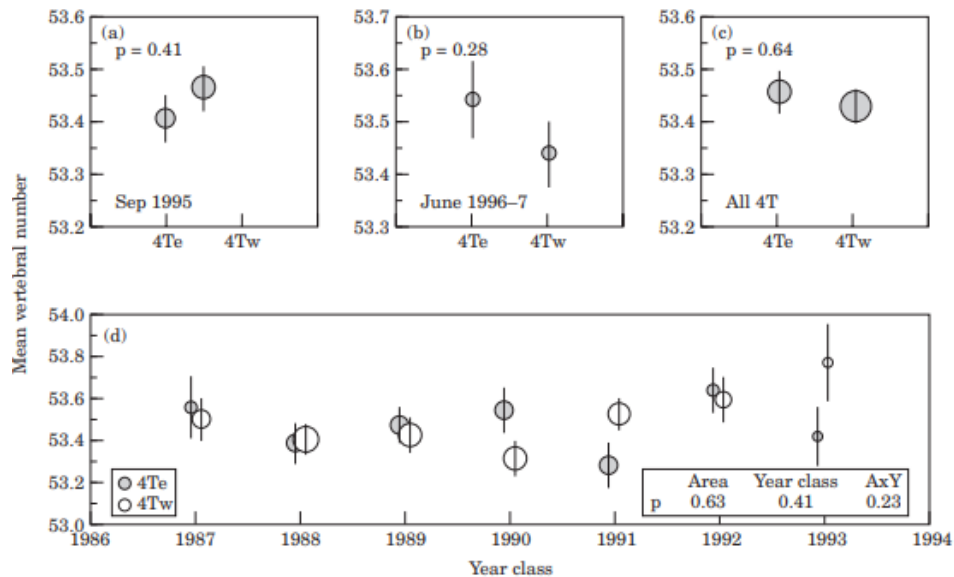


Figure 8. Vertebral counts in eastern (4Te) and western (4Tw) regions of the southern Gulf of St. Lawrence during the spring spawning and summer feeding periods. (a) September 1995,  $p=0.41$ . (b) June 1996–1997,  $p=0.28$ . (c) All 4T,  $p=0.64$ . (d) Mean vertebral number vs. year-class.  $p$  gives the probability that counts differ between 4Te and 4Tw in (a)–(c) and for the ANOVA terms in (d). Symbol size is proportional to sample size (maximum of 860 in top panels, 175 in bottom panel). Vertical lines show 1 s.e. From Swain et al. (2001).

Despite the utility of meristic characters for investigating the stock identity of Atlantic cod, this technique has not been routinely applied in U.S. waters or the Bay of Fundy. In an early study, Schmidt (1930) investigated vertebral counts of cod taken from Nantucket Shoals (mean = 51.9) and Mt. Desert Island (mean = 53.0). Later, Templeman (1962) reported similarities in vertebral counts between cod taken from the Northeast Peak of Georges Bank (mean = 52.7) and Browns Bank (means ranged from 52.5 to 53.0), although the sample sizes were not reported. Given the utility and cost effectiveness of this approach, the Working Group notes that analysis of meristic characters may be informative for future multidisciplinary stock identification studies in the region.

## **Morphometrics**

General morphometry (i.e., body shape analysis) has long been used to aid in identification of stock structure in fish (Meng and Stocker 1984, Haddon and Willis 1995, Begg and Waldman 1999, Cadrin and Silva 2005). Morphometrics are known to be influenced by both genetics and the environment, which can lead to subtle differences in body shape among populations (Swain et al. 2005). For example, some populations may be adapted for more migratory behavior than others which may be more sedentary, and this may lead to differences in body shape (e.g., migrants should be more streamlined than residents, Morinville and Rasmussen 2008). Differences in diet among regions may also drive differences in body shape.

Sherwood and Grabowski (2010) found that red cod at Cashes Ledge (central GOM) have deeper bodies, shorter snouts, and more slender tails than normal (olive) cod which is likely a result of their sedentary behavior, but could also be related to a more crustacean dominated diet (i.e., large crabs and lobsters).

Sherwood and Grabowski (2012) sampled 370 cod in the Gulf of Maine and on Georges Bank between from 2007-2009 using hook and line (Figure 9). Morphological characters were measured using a box truss network, and step-wise discriminant function analysis was used to classify samples to their original spatial grouping. Samples from Georges Bank and the Gulf of Maine could be classified to their original groups with an accuracy of 69.5%. However, classification accuracy was higher for samples taken from eastern and western Georges Bank (76.8%), and the authors concluded that “there is some important structure on Georges Bank that is not captured by the current stock definitions”. The morphometric results suggested that cod on eastern Georges Bank were more streamlined than western Georges Bank cod, which may be reflective of differences in their migratory behaviors.

The results of Sherwood and Grabowski (2012) also pointed to fine-scale structure within the Gulf of Maine, as samples from the eastern (Cashes Ledge) and western (Bigelow Bight, Platts Bank, and Sheepscot Bay) Gulf of Maine could be assigned to their group of origin with a 90.7% classification accuracy. The authors concluded that there may be population structuring within the Gulf of Maine that is not accounted for in management, but noted that little corroborating information from other disciplines (e.g., tagging and genetics) was available to support this conclusion. Interestingly, cod on Platts Bank, which is an intermediate distance offshore between the eastern (Cashes Ledge) and western (Bigelow Bight and Sheepscot Bay) sample locations, grouped with samples from both the eastern and western areas, suggesting this area may serve as a boundary between populations (Figure 9). This boundary also agreed well with Ames' (2004) sub-stock delineations (i.e., western and mid-coast sub-populations).

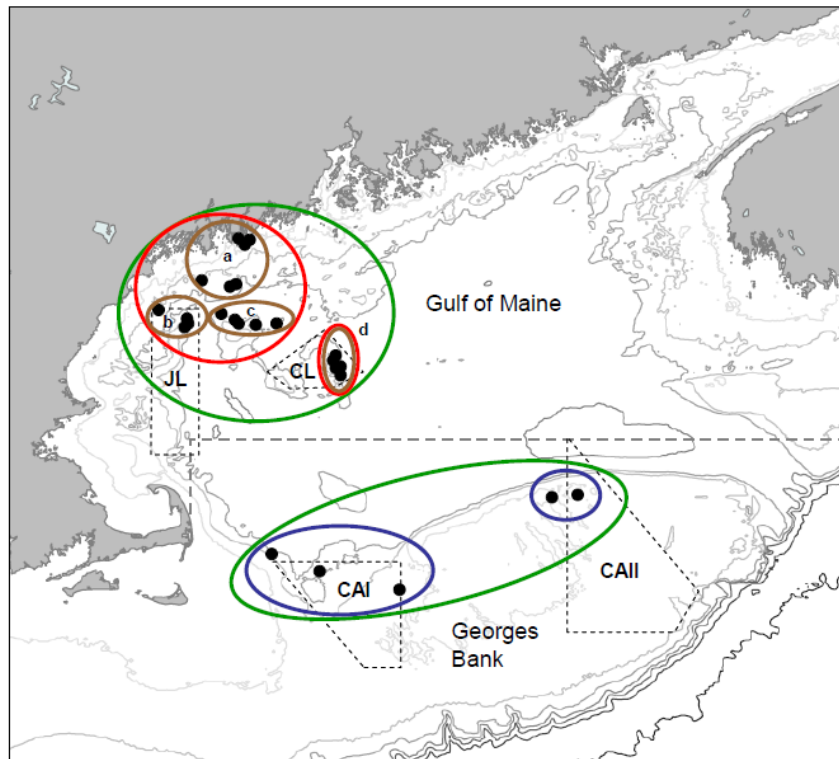


Figure 9. Map of Gulf of Maine and Georges Bank showing location of sampling sites (black dots) for morphometric analysis (Sherwood and Grabowski 2012). Four year-round closed areas are also shown (dashed polygons): CAI, closed area I; CAII, closed area II; CL, Cashes Ledge closure area; JL, Jeffreys Ledge or western Gulf of Maine closure area. Dashed line shows division between GOM and GB stocks. Green ellipses indicate groupings for comparison 1 (Gulf of Maine vs. Georges Bank), blue ellipses are groupings for comparison 2 (eastern vs. western GB), red ellipses are groupings for comparison 3 (eastern vs. western GOM), and brown ellipses are groupings for comparison 4: a) Bigelow Bight + Sheepscot; b) Jeffreys Ledge; c) Platt's Bank; d) Cashes Ledge.

Kerr et al. (2018) included morphometric methods among a suite of others for investigating the differences between spring and winter spawning cod in both Massachusetts and Ipswich Bays,



based on 260 near spawning condition fish from the four spawning groups. A box-truss network was created with 12 homologous landmarks and 22 linear measurements and discriminant function (DF) analysis was performed. The largest discrimination was between Massachusetts and Ipswich Bay fish along DF1, rather than between spring- and winter-spawning cod, although in both bays spring- and winter-spawning cod were distinguishable along DF2. Overall, 82.3% of cod were correctly reclassified back to their original groupings suggesting that body shape alone is a good means of discriminating between spawning groups. Massachusetts Bay, in particular, had very high reclassification rates (90%). Reclassification rates were even higher (84.3%) when RGR (color) was added as a discriminating variable. These reconstructions consistently show that spring-spawning cod, regardless of location, are more streamlined, and therefore probably more migratory, than winter-spawning cod.

### *Tissue characteristics: stable isotope concentrations and fatty acid profiles*

Fatty acid profiles have been used as natural marks for stock identification for several marine species, including cod (Grahl-Nielsen 2005, Grahl-Nielsen 2014). The fatty acid composition in the tissues of a fish is influenced by several factors including their genotype, and external factors such as diet and environmental conditions (Kirsch et al. 1998, Grahl-Nielsen, 2005; 2014). Over 20 fatty acids have been used as stock identification markers, and principal component analysis is typically used to quantify differences amongst groups (Grahl-Nielsen 2005).

Fatty acids have been used successfully to differentiate cod stocks on the Faroe Plateau and the Faroe Bank (Joensen et al. 2000). Furthermore, fatty acid profiles of cod muscle and heart tissue from Northeast Atlantic stocks (Faroe Bank, Faroe Plateau, North-West Iceland, Norway-Barents Sea and Denmark-Skagerrak) provided high classification accuracy (89%; Joensen et al. 2014). Fatty acid profiles for cod off Canada have been analyzed for estimating consumption by marine mammals, and a similar study is being investigated for New England samples of cod, but the approach has not been applied for cod stock identification in the northwest Atlantic (cite).

Fatty acid profiles and stable isotope concentrations have not been routinely applied to investigate cod stock structure in US waters. Sherwood and Grabowski (2016) investigated the body shape, condition, diet, age and size structure, and stable isotopes of cod inside and outside of the groundfish closed areas (Closed Areas I and II, Cashes Ledge, and Jeffreys Ledge) in US waters. Although this study was not specifically designed to investigate stock structure, they did find differences in the  $\delta^{13}\text{C}$  and  $\delta^{15}\text{N}$  ratios of cod inside and outside of the closed areas, suggesting that cod within closed areas consumed a wider range of prey items.

### *Parasites*

The utility of parasites as a natural tag to identify connectivity and stock structure has been identified in many species, in many oceans, and in several reviews (e.g., MacKenzie 1987, Timi 2007, Catalano et al. 2014). Atlantic cod are rich in parasites across their range: a single study identified 57 different parasites in eastern Atlantic cod (Perdiguero-Alonso et al. 2008) and a review of the literature identified 107 proto-/metazoan parasites of cod (Hemminson and MacKenzie, 2001).



In the northwest Atlantic, the most detailed study in US waters is that of Sherman and Wise (1961), who studied infestation rates of the parasitic copepod, *Lernaeocera branchialis*, across New England's waters (Figure 10). These rates were interpreted to represent four stocks of cod: 1) a heavily infested group in the northern Gulf of Maine, 2) a moderately infested group of central and southern Gulf cod, 3) a lightly infested group on Georges Bank, and 4) a group free of infestation in the Southern New England region. This supported previous unpublished tag return data (Wise 1963), and indicated the usefulness of *Lernaeocera* for distinguishing groups of cod across broad areas. In Canadian waters, use of parasites in defining stock structure was reported by Martin (1953; unspecific as to taxa or methods used), as well as in research reported for the Gulf of St. Lawrence (McClelland and Marcogliese 1994 [nematodes], McClelland and Melendy 2011 [multiple parasites]), and Newfoundland (Khan and Tuck 1995 [multiple parasites]).

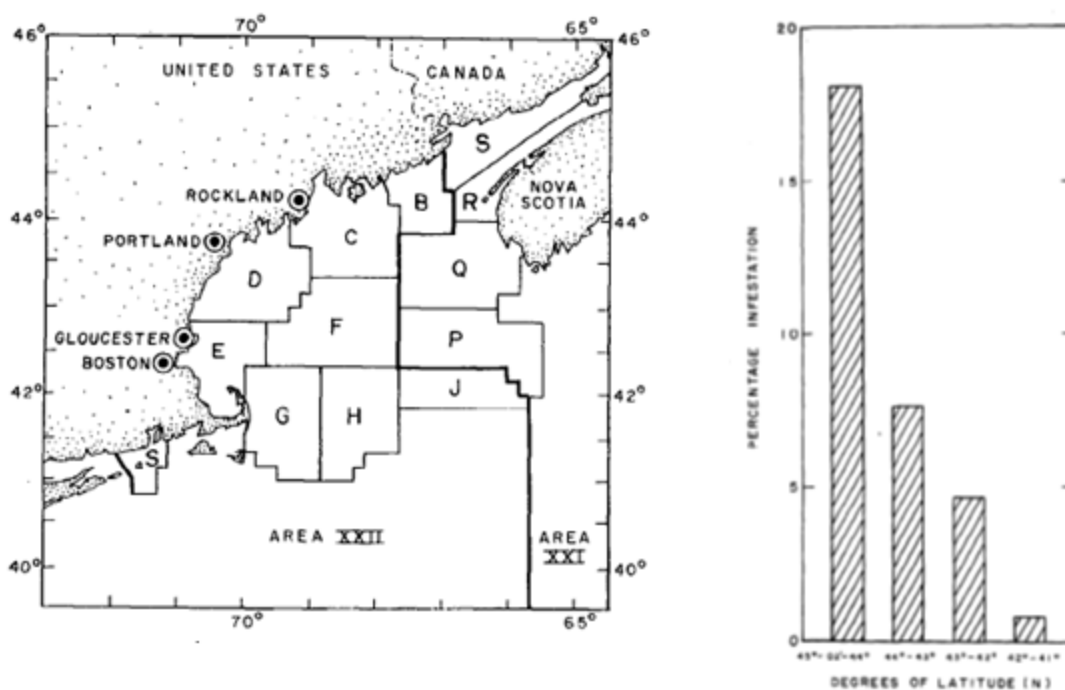


Figure 10. Figures from Sherman and Wise (1961) showing sampling areas and parasite infestation rates of cod by latitude.

The potential of parasites for stock structure analysis of cod has been realized in the past, but has been largely dormant in recent years. Although the promise of this method is that fish can be readily screened for parasites from fishery-dependent or fishery-independent collections, several challenges remain: 1) sampling at an appropriate scale and with a framework to infer population-level processes, 2) partnering with appropriate taxonomic expertise of parasites, 3) selection of parasites with appropriate life history to address the questions of stock connectivity or separation, and 4) demonstrated advantage of this method to complement other phenotypic methods for stock identification or discrimination. Furthermore, there is the issue of assuming that the dynamics of the parasite population is stationary in time and space. For example, an increase in infection rates in an area could wrongly be interpreted as an increase/immigration of a particular group of cod, when in reality it may be caused by the spread of the parasite.

## *Multiple natural markers*

Genetic and genomic methods are one of the most powerful of the suite of natural markers and these methods and their application to cod are detailed in Chapter 3. Genetic methods are oftentimes applied in combination with other natural markers and can serve as effective and complementary tools to other techniques, such as otolith chemistry or body morphometrics, in the identification of stock structure (Campana 2005; Sturrock et al. 2012, Cadrin 2014). Genetics can provide insight on the spawning group of origin of cod, whereas other techniques, like otolith chemistry and body morphometrics, can provide insight on the spatial behavior and life history type (resident vs. migratory) of cod (Secor et al. 2001, Morinville and Rasmussen 2008, Sherwood and Grabowski 2010). Applying modern, genomic tools can further characterize ecological diversity by identifying adaptive variation among populations.

The number of natural markers to choose from necessitates a strategic approach to match them -- with each other or with other stock identification methods -- so as to investigate cod biology and ecology in an integrated manner. In ongoing work by Kerr et al. (2018), a combination of genetics, genomics, otolith chemistry, otolith structure, morphometric, and color analysis was applied to winter and spring spawning fish from the two main spawning locations in the Gulf of Maine (Ipswich and Massachusetts Bays) to characterize their genetic, spatial, and life history diversity. Genetic analysis indicated significant neutral and adaptive genetic differentiation between winter and spring spawners sampled over multiple years, suggesting limited connectivity as well as ecological differentiation in these two spawning populations. Otolith chemistry analysis indicated significant differences in elemental ratios of winter and spring spawners within each Bay that suggested differences in environmental conditions experienced early in life and habitat use by these groups over their lifetime. Morphometric analysis indicated that winter and spring spawning cod exhibit significant differences in body shape, with winter spawners having features often associated with a more resident life history (deeper bodied and shorter head) than spring spawners. These three methods provided largely congruent results; taken together, these point toward biocomplexity of Atlantic cod on a fine scale, consistent with local adaptation and ecological divergence.

Through mixed stock analysis, Kerr et al. (2018) also determined the relative contribution of these two spawning complexes to samples from the current commercial fishery and compared it with the composition of the fishery in two time periods in the past (1979-1982 and 1989-1992). Genetic and otolith analyses indicated that the composition of the fishery has changed over time: a greater proportion of winter spawners comprise the fishery today compared with the past. Furthermore, the genetic data suggests that the historical fishery may have been characterized by a greater diversity than it is today.

## **Synthesis of Findings to Date**

- The natural markers applied to cod include otolith characteristics (chemistry, shape, and structure), tissue characteristics (stable isotopes concentrations and fatty acid profiles), body characteristics (color type, morphometrics, and meristics), and other features, such as parasites.

- The morphometric results of Sherwood and Grabowski (2012) suggest that cod on eastern and western Georges Bank may comprise unique groups, although the boundary between these groups could not be identified. These results are in broad agreement with genetic analyses (e.g., Kovach et al. 2010), tagging studies (Wise 1963; Hunt et al. 1999; Tallack 2011), and Fishermen’s Ecological Knowledge (Section 7).
- Natural markers (otolith chemistry, structure and morphometrics) support winter and spring spawners as unique groups. This finding is in agreement with genetic analyses (Kovach et al. 2010).
  - Otolith chemistry analysis indicated significant differences in elemental ratios of winter and spring spawners within each Bay, both early in life and across their lifetime, suggesting differences in environmental conditions experienced early in life and habitat use by these groups over their lifetime.
  - Morphometric analysis indicated that winter and spring spawning cod in the western Gulf of Maine exhibit significant differences in body shape with winter spawners having features often associated with a more resident life history (deeper bodied and shorter head) than spring spawners.
  - Otolith structure analysis supports significant differences in growth and mortality between the winter and spring spawning cod in the western Gulf of Maine, where winter-spawners grow and mature at a faster rate, but spring-spawners reach a larger maximum size.
  - The three methods provided largely congruent results, and taken together, the results point toward biocomplexity of Atlantic cod on a fine scale, consistent with local adaptation and ecological divergence.
- Parasite infestation rate suggests separation between the northern Gulf of Maine, central Gulf, Georges Bank, and Southern New England cod.

### **Further research needs/priorities**

- Natural markers have been more widely applied for cod in the Gulf of Maine, and on Georges Bank, but have not been routinely used for cod in southern New England, Nantucket Shoals, or the Great South Channel. Applying natural markers to samples collected in these regions would provide complementary information to results collected through other disciplines, like genetics and tagging. In particular, natural markers may be especially useful for stock composition analysis of cod captured on western Georges Bank.
- Meristic characters have proven useful for stock identification of Atlantic cod, but have not been routinely applied in U.S. waters. Given their low cost, utility, and ease of collection, future multidisciplinary stock identification studies should consider investigating meristic characters.
- Otolith shape has great potential, but has not been applied extensively in U.S. waters.
- Based on historical studies and information from fishermen, parasitological investigation in the Gulf of Maine region may be a cost-effective approach to stock identification.

- Examining color morphs for cod may have utility for stock composition analysis. However, color morphs are often defined using colloquial names or qualitative criteria, and coloration is rarely quantified, which can make interpretation and comparisons difficult. Therefore, we recommend that quantitative metrics of color, such as those employed by Sherwood and Grabowski, 2010, be used whenever possible to aid in the interpretation of results.

## **Acknowledgements**

We thank Micah Dean, Graham Sherwood, and Zach Whitener for their reviews of this chapter which greatly improved the final product.

## References

- Abaunza P, Murta AG, Campbell N, Cimmaruta R, Comesaña S, Dahle G, Gallo E, Garcia Santamaria MT, Gordo L, Iversen S, MacKenzie K, Magoulas A, Mattiucc, S, Molloy J, Nascetti G, Pinto AL, Quinta R, Ramos P, Ruggi A, Sanjuan A, Santos AT, Stransky C, Zimmermann C. 2008. Considerations on sampling strategies for an holistic approach to stock identification: the example of the HOMSIR project. *Fish Res.* 89:104-113.
- Ames E. P. 2004. Atlantic cod stock structure in the Gulf of Maine. *Fisheries*, 29:10–28.
- Barlow GW. 1961. Causes and significance of morphological variation in fishes. *Syst Zool.* 10:105-117.
- Begg GA, Waldman JR. 1999. An holistic approach to fish stock identification. *Fish Res.* 43(1-3):35-44.
- Berg E, Sarvas T, Harbitz A, Fevolden SE, Salberg AB. 2005. Accuracy and precision in stock separation of north-east Arctic and Norwegian coastal cod by otoliths –comparing readings, image analysis and a genetic method. *Mar Freshwater Res.* 56:753-762
- Bigelow HB, Schroeder WC. 1953. Fishes of the Gulf of Maine. *Fish Bull.* 53:1-577.
- Brophy D. 2014. Analysis of growth marks in calcified structures: insights into stock structure and migration pathways." In: Cadrin SX, Kerr LA, Mariani S, editors. *Stock identification methods: applications in fishery science*. 2nd ed. Miami (FL): Elsevier Inc. p. 141-170.
- Cadrin SX, Silva VM. 2005. Morphometric variation of yellowtail flounder. *ICES J Mar Sci.* 62(4):683-694.
- Cadrin SX, Kerr LA, Mariani, S, editors. 2014. *Stock identification methods: applications in fishery science*. 2nd ed. Miami (FL): Elsevier Inc. 588 pp.
- Campana SE, Casselman JM. 1993. Stock discrimination using otolith shape analysis. *Can J Fish and Aquat Sci.* 50:1062-1083.
- Campana SE, Fowler AJ, Jones, CM. 1994. Otolith elemental fingerprinting for stock identification of Atlantic cod (*Gadus morhua*) using laser ablation ICPMS. *Can J Fish Aquat Sci.* 51:1942-1950.
- Campana, SE, Gagné, JA, McLaren, JW. 1995. Elemental fingerprinting of fish otoliths using ID-ICOMS. *Mar Ecol Prog Ser.* 122:115-120.
- Campana SE, Chouinard GA, Hanson JM, Fréchet A. 1999. Mixing and migration of overwintering Atlantic cod (*Gadus morhua*) stocks near the mouth of the Gulf of St. Lawrence. *C J Fish Aquat Sci.* 56:1873-1881.

- Campana SE, Chouinard GA, Hanson JM, Fréchet A, Brattey J. 2000. Otolith elemental fingerprints as biological tracers of fish stocks. *Fish Res.* 46:343-357.
- Campana SE. 2005. Otolith elemental composition as a natural marker of fish stocks. In: Cadrin, SX, Friedland, KD, Waldman, JR, editors. *Stock identification methods: applications in fishery science.* Amsterdam: Elsevier Academic Press. p. 227-245.
- Catalano, SR, Whittington, ID, Donnellan, SC, Gillanders, BM. 2014. Parasites as biological tracers to assess host population structure: guidelines, recent generic advances and comments on a holistic approach. *Int J Parasitol-Par.* 3(2):2202-226.
- Chase PD. 2014. Meristics. In: Cadrin SX, Kerr LA, Mariani S, editors. *Stock identification methods: applications in fishery science.* 2nd ed. Miami (FL): Elsevier Inc. p. 171-184.
- Clarke LM, Thorrold SR, Conover DO. 2011. Population differences in otolith chemistry have a genetic basis in *Menidia menidia*. *Can J Fish Aquat Sci.* 68:105-114.
- Conroy, C.W. 2016. The behaviors, habitat preferences, and ecology of distinct Atlantic cod phenotypes in the Gulf of Maine. Doctoral dissertation, Northeastern University, Nahant, MA.
- Conroy, C.W., Calvert, J., Sherwood, G.D., Grabowski, J.H. 2017. Distinct responses of sympatric migrant and resident Atlantic cod phenotypes to substrate and temperature at a remote Gulf of Maine seamount. *ICES J Mar Sci.* 75: 122-134.
- Dean MJ, Elzey SP, Hoffman WS, Buchan NC, Grabowski JH. 2019. The relative importance of sub-populations to the Gulf of Maine stock of Atlantic cod. *ICES J Mar Sci.* 76(6):1626-1640.
- Elsdon TS, Wells BK, Campana SE, Gillanders BM, Jones CM, Limburg KE, Secor DH, Thorrold SR, Walther BD. 2008. Otolith chemistry to describe movements and life-history parameters of fishes: hypotheses, assumptions, limitations and inferences. *Oceanog Mar Biol.* 46:297-330.
- Gosse KR, Wroblewski JS. 2004. Variant colorations of Atlantic cod (*Gadus morhua*) in Newfoundland and Labrador nearshore waters. *ICES J Mar Sci.* 61:752-759.
- Grahl-Nielsen O. 2005. Fatty acid profiles as natural marks for stock identification. In: Cadrin SX, Friedland KD, Waldman JR, editors. *Stock identification methods: applications in fishery science.* Amsterdam: Elsevier Academic Press. p. 247-269.
- Grahl-Nielsen O. 2014. Fatty acid profiles as natural marks for stock identification. In: Cadrin SX, Kerr LA, Mariani S, editors. *Stock identification methods: applications in fishery science.* 2nd edition. Miami (FL): Elsevier Inc. p. 235-256.
- Haddon H, Willis TJ. 1995. Morphometric and meristic comparison of orange roughy (*Hoplostethus atlanticus*: Trachichthyidae) from the Puysegur Bank and Lord Howe Rise, New Zealand, and its implications for stock structure. *Mar Bio.* 123(1):19-27.

- Heino M. 2014. Quantitative traits. In: Cadrin SX, Kerr LA, Mariani S, editors. Stock identification methods: applications in fishery science. 2nd edition. Miami (FL): Elsevier Inc. p. 59-76.
- Hemminson W, MacKenzie K. 2001. The parasites fauna of Atlantic cod, *Gadus morhua* L. Adv Mar Bio. 40:1-80.
- Hunt JJ, Stobo WT, Almeida F. 1999. Movement of Atlantic cod, *Gadus morhua*, tagged in the Gulf of Maine. Fish Bull. 97(4):842-860.
- Hüssy K, Hinrichsen H-H, Eero M, Mosegaard H, Hemmer-Hansen J, Lehmann A, Lundgaard LS. 2016. Spatio-temporal trends in stock mixing of eastern and western Baltic cod in the Arkona Basin and the implications for recruitment. ICES J Mar Sci. 73(2):293-303.
- Joensen H, Steingrund P, Fjallstein I, Grahl-Nielsen O. 2000. Discrimination between two reared stocks of cod (*Gadus morhua*) from the Faroe Islands by chemometry of the fatty acid composition in the heart tissue. Mar Bio. 136(3):573-580.
- Joensen H, Grahl-Nielsen O. 2014. Distinction among North Atlantic cod *Gadus morhua* stocks by tissue fatty acid profiles. J Fish Biol. 84(6):1904-1925.
- Kerr LA, Cadrin SX, Secor, DH. 2010. The role of spatial dynamics in the stability, resilience, and productivity of an estuarine fish population. Ecol Appl. 20(2):497-507.
- Kerr LA, Campana SE. 2014. Chemical composition of fish hard parts as a natural marker of fish stocks. In: Cadrin, SX, Kerr, LA, Mariani, S, editors. Stock identification methods: applications in fishery science. 2nd edition. Miami (FL): Elsevier Inc. p. 205-234.
- Kerr LA, Sherwood G, Kovach A, Cadrin SX, Goethel D, Zemeckis D, Whitene, ZT. 2018. Ecological diversity of Atlantic cod in the Gulf of Maine and its role in resiliency of a fishery. NOAA Completion Report NA14NMF4270014.
- Khan RA, Tuck C. 1995, Parasites as biological indicators of stocks of Atlantic cod (*Gadus morhua*) off Newfoundland, Canada. C J Fish Aquat Sci. 52(S1):195-201.
- Kirsch PE, Iverson SJ, Bowen WD, Kerr SR, Ackman R.G. 1998. Dietary effects on the fatty acid signature of whole Atlantic cod (*Gadus morhua*). C J Fish Aquat Sci. 55:1378-1386.
- Kovach AI, Breton TS, Berlinsky DL, Maceda L, Wirgin I. 2010. Fine-scale spatial and temporal genetic structure of Atlantic cod off the Atlantic coast of the USA. Mar Ecol Prog Ser. 410:177-195.
- Loken S, Pedersen T. 1996. Effect of parent type and temperature on vertebrae number in juvenile cod, *Gadus morhua* (L.), in northern Norway. Sarsia. 80:294-298.
- MacKenzie RA, Smith GFM. 1955. Atlantic cod populations along the southern Canadian mainland as shown by vertebral count studies. C J Fish Aquat Sci. 12(5):698-705.

- MacKenzie K. 1987. Parasites as indicators of host populations. *Int J Parasitol.* 17(2):34-352.
- Martin WR. 1953. Identification of major groundfish stocks in sub-area 4 of the Northwest Atlantic Convention Area. ICNAF, 3rd Annual Meet(99). p. 6.
- McClelland G, Marcogliese DJ. 1994. Larval anisakine nematodes as biological indicators of cod (*Gadus morhua*) populations in the southern Gulf of St. Lawrence and on the Breton Shelf, Canada. *Bull Scand Soc Parasitol.* 4(2):97-116.
- McClelland G, Melendy J. 2011. Use of parasites as tags in delineating stocks of Atlantic cod (*Gadus morhua*) from the southern Gulf of Lawrence and Cape Breton Shelf. *Fish Res.* 107(1-3):233-238.
- Meng JM, Stocker M. 1984. An evaluation of morphometrics and meristics for stock separation of Pacific herring (*Clupea hangues pallasi*). *C J Fish Aquat Sci.* 41(3):414-422.
- Morrinville GR, Rasmussen JB. 2008. Distinguishing between juveniles anadromous and resident brook trout (*Salvelinus fontinalis*) using morphology. *Environ Biol Fish.* 81:171-184.
- Pepin P, Carr SM. 1993. Morphological, meristic, and genetic analysis of stock structure in juvenile Atlantic cod (*Gadus morhua*) from the Newfoundland shelf. *C J Fish Aquat Sci.* 50(9):1924-1933.
- Perdiguero-Alonso D, Montero FE, Raga JA, Kostadinova A. 2008. Composition and structure of the parasite faunas of cod, *Gadus morhua* L. (Teleostei: Gadidae), in the north east Atlantic. *Parasite Vector.* 1(23).
- Schmidt J. 1930. The Atlantic cod and local races of the same. *C R Lab Carlsberg.* 18(6):1-71.
- Secor D, Rooker JR, Zlokovitz E, Zdanowicz VS. 2001. Identificaiton of riverine, estuarine, and coastal contingents of Hudson River striped bass based upon otolith elemental fingerprints. *Mar Ecol Prog Ser.* 211:245-253.
- Sherman K, Wise JP. 1961. Incidence of the cod parasite *Lernaeocera branchialis* L. in the New England area, and its possible use as an indicator of cod populations. *Limnol Oceanog.* 6(1):61-67.
- Sherwood, GD, Grabowski JH. 2010. Exploring the life-history implications of colour variation in offshore Gulf of Maine cod (*Gadus morhua*). *ICES J Mar Sci.* 67:1640-1649.
- Sherwood GD, Grabowski JH. 2012. Morphometric analysis of Gulf of Maine and Georges Bank cod. Report from the 2012 Cod Stock Structure Working Group. Available at: [https://www.gmri.org/sites/default/files/resource/cod\\_workshop\\_final\\_report\\_25\\_july\\_2012.pdf](https://www.gmri.org/sites/default/files/resource/cod_workshop_final_report_25_july_2012.pdf)



- Sherwood GD, Grabowski JH. 2016. A comparison of life-history parameters inside and outside of four year-round groundfish closed areas in New England, USA. *ICES J Mar Sci.* 73(2):316-328.
- Stransky C, Baumann H, Fevolden S-E, Harbitz A, Høie H, Nedreaas KH., Salberg A-B, Skarsten TH. 2008. Separation of Norwegian coastal cod and Northeast Arctic cod by outer otolith shape analysis. *Fish Res.* 90:26-35.
- Stransky C. 2014. Morphometric outlines. In: Cadrin SX, Kerr LA, Mariani S, editors. *Stock identification methods: applications in fishery science.* 2nd edition. Miami (FL): Elsevier Inc. p. 129-140.
- Sturrock AM, Trueman CN, Darnaude AM, Hunter E. 2012. Can otolith elemental chemistry retrospectively track migrations in fully marine fishes? *J Fish Biol.* 81(2):766-795.
- Sturrock AM, Hunter E, Milton JA, EIMF, Johnson RC, Waring CP, Trueman CN. 2015. Quantifying physiological influences on otolith microchemistry. *Methods Ecol Evol.* 6:806-816.
- Swain DP, Frank KT, Maillet G. 2001. Delineating stocks of Atlantic cod (*Gadus morhua*) in the Gulf of St Lawrence and Cabot Strait using vertebral number. *ICES J Mar Sci.* 58:253-269.
- Swain, D., Hutchings, J., Foote, C. 2005. Environmental and Genetic Influences on Stock Identification Characters. In: Cadrin SX, Friedland KD, Waldman JR, editors. *Stock identification methods: applications in fishery science.* Amsterdam: Elsevier Academic Press. p. 45-85
- Tallack SM. 2009. Regional growth estimates of Atlantic cod, *Gadus morhua*: applications of the maximum likelihood GROTAG model to tagging data in the Gulf of Maine (USA/Canada) region. *Fish Res.* 99(3):137-150.
- Templeman, W. 1962. Divisions of cod stocks in the northwest Atlantic. *ICNAF Redbook Part III*:79-129.
- Templeman, W. 1981. Vertebral numbers in Atlantic cod, *Gadus morhua*, of the Newfoundland and adjacent areas, 1947-71, and their use for delineating cod stocks. *J Northwest Atl Fish Sci.* 2:21-45.
- Timi JT. 2007. Parasites as biological tags for stock discrimination in marine fish from South American Atlantic waters. *J Helminthol.* 81(2):107-111.
- Waldman JR. 2005. Meristics. In: Cadrin SX, Friedland KD, Waldman JR, editors. *Stock identification methods: applications in fishery science.* Amsterdam: Elsevier Academic Press. p. 197-210.

Wise, JP. 1963. Factors affecting number and quality of returns from tagging cod with different tags and using different methods of capture in 4X and 5Y in 1957. *Int Comm Northwest Atl Fish, Spec Pub.* 4:101-106.

Wroblewski J, Neis B, Gosse, K. 2005. Inshore stocks of Atlantic cod are important for rebuilding the east coast fishery. *Coast Manage.* 33:411-432.

Vignon M, Morat, F. 2010. Environmental and genetic determinant of otolith shape revealed by a non-indigenous tropical fish. *Mar Ecol Prog Ser.* 411:231-241.

## CHAPTER 7. APPLIED MARKERS

SubGroup: Steven X. Cadrin, Douglas R. Zemeckis, Micah J. Dean and Jamie Courane  
Reviewers: Greg DeCelles, Don Clark, David Goethel

### Abstract

A comprehensive review of conventional and electronic tagging of Atlantic cod in the Gulf of Maine region and adjacent areas (NAFO divisions 4X, 5, 6) and analysis of available conventional and archival tag data show persistent patterns of movement and residence. Published tagging studies and updated analyses of available tagging data, including nearly 200,000 tag releases and nearly 12,000 recaptures as well as information from acoustic and archival tags, were used to identify major patterns of residence and movement among regions and fishing grounds. There is little movement of cod between the eastern and western Scotian Shelf; cod groups within the Bay of Fundy, the western Gulf of Maine, southern New England, and the Mid Atlantic Bight are relatively sedentary; but there is substantial movement from Browns Bank to the Bay of Fundy and the western Scotian Shelf, from the Great South Channel to the western Gulf of Maine, and from eastern Georges Bank to Browns Bank. Analysis of residence and dispersal of distinct spawning groups among fishing grounds suggest high residence and fidelity to spawning areas in the western Gulf of Maine and the Bay of Fundy, moderate spawning site fidelity on eastern Georges Bank with some post-spawning dispersal, and greater dispersal from the ‘Cape Cod’ spawning grounds. Major movement patterns are consistent among studies and across recent decades of tagging studies, but the frequency of residence and movement vary.

### Introduction

Tagging studies can inform inferences of the degree of connectivity among distinct population components. Conventional tags document movements from release to recapture location (Hall 2014) and electronic tags provide information on movement trajectories, habitat utilization, behavior, and spawning dynamics (DeCelles and Zemeckis 2014). Fishery recaptures of conventional tags are influenced by spatiotemporal patterns in fishing effort, but information from electronic tags is largely fishery-independent.

The objective of this chapter is to contribute to an interdisciplinary evaluation of cod stock identity by 1) reviewing all published information on cod tagging in the Gulf of Maine and adjacent areas (NAFO divisions 4X, 5, 6) from conventional and electronic tagging, and 2) analyzing movement patterns among fishing grounds using the available conventional and archival tag data in the context of putative spawning groups, as identified in Chapters 2 and 3 (genetics and early life history). This summary extends and synthesizes previous reviews (Schroeder 1930, McKenzie 1956; Wise and Jensen 1960; Templeman 1962; Loehrke and Cadrin 2007; Wang et al. 2009; Clark and Emberley 2010; Zemeckis et al. 2014b) drawing on source material and conclusions from previous reviews.

#### *Review of Conventional Tagging Studies*

The earliest tagging studies of New England cod were in association with hatchery experiments (Tarr 1884). Smith (1902) tagged and released 4,000 cod from Woods Hole, Massachusetts and reported recaptures on Nantucket Shoals and in the Mid Atlantic Bight. Rich (1925) tagged on

Nantucket Shoals, and tagging continued annually until 1932, primarily on Nantucket Shoals but also in other areas (Higgins 1934). Schroeder (1930) reviewed data from tagging on Nantucket Shoals and concluded that the group of cod on Nantucket Shoals is mostly distinct from those to the north and east, but cod from Nantucket Shoals move off Rhode Island and to the Mid Atlantic in fall. Wise (1958) tagged cod off New Jersey in winter and confirmed the seasonal pattern described by Schroeder (1930).

Higgins (1929) reviewed tagging data from other areas and concluded that cod from northern Massachusetts Bay to eastern Maine and the offshore Gulf of Maine banks were relatively sedentary, but cod from Massachusetts Bay tend to migrate to the south. Tagging off the coast of Maine had mostly local recaptures, and some moved east (Higgins 1933), but the cod off the Maine coast were not considered to be connected to those on the Georges Bank and Browns Bank (Higgins 1934). Wise and Jensen (1960) reviewed this historical tagging information and concluded that cod in the Gulf of Maine are relatively sedentary. Higgins (1931) described tagging on Browns Bank and concluded that most movement was north and northeast with a little to the south and west. Tagging on Georges Bank suggested that most fish stayed on the Bank with movement to Browns Bank and less to Nantucket Shoals and southward (Higgins 1931).

McKenzie (1956) reviewed recapture patterns of cod tagged in the Bay of Fundy, the Scotian Shelf, and the Gulf of St. Lawrence. Only a few cod were tagged in the Bay of Fundy in 1938 and 1939, and all were recaptured in the Bay of Fundy, except one cod tagged off St. Andrews that was recaptured on Georges Bank. McKenzie (1956) concluded that cod tagged in summer inshore from the Bay of Fundy and other inshore locations on the Scotian Shelf are mostly stationary, with little offshore mixing. Recaptures of cod tagged off Seal Island (Western Scotian Shelf) were generally eastward in summer and westward and deeper in winter. By contrast, all recaptures of cod tagged off Shelburn (southeast Nova Scotia) were to the north, suggesting little movement to the western Scotian Shelf, Gulf of Maine, Browns Bank, or Georges Bank from the eastern Scotian Shelf. Templeman (1962) reviewed the tagging information reported by McKenzie (1956) and noted that only 11 of 2,200 recoveries from cod tagged off the eastern Scotian Shelf (Fundian Channel to the Laurentian Channel) were recaptured on New England fishing grounds. In an interdisciplinary evaluation of stock identity of cod in the Bay of Fundy, Hunt and Neilson (1993) analyzed these tagging data by adjusting for patterns in fishing effort, and they found extensive movement between the eastern and western Bay of Fundy.

Wise (1963) completed a regional, four-year tagging investigation to study New England cod stock structure. Most cod tagged on the northeast peak of Georges Bank during the spawning season (March-April 1957) were recaptured on eastern Georges Bank (64%), and some moved to Browns Bank and the western Scotian Shelf (36%). Most cod tagged on Browns Bank during the spawning season (February-March 1957) were recaptured on Browns Bank (86%), with some movement of cod to Eastern Georges Bank (14%). Most cod tagged off Chatham (Cape Cod MA) in February-March 1957 were recaptured in the Great South Channel (74%), and some moved to the Gulf of Maine (15%), southern New England-Mid Atlantic (6%), Georges Bank (3%), and the Scotian Shelf (1%). Recaptures of cod tagged on Georges and Browns Bank were distributed almost entirely on offshore banks and the western Scotian Shelf, but recaptures of cod tagged off Chatham were distributed throughout the region (from the Mid Atlantic to the Scotian Shelf). Wise and Jensen (1960) and Wise (1963) concluded that cod on eastern Georges Bank have limited mixing west of 68°W, but some older fish move to southwestern Nova Scotia.

Perkins et al. (1997) tagged 4,191 cod in Sheepscot Bay (southern Maine) during March-July, 1978-1983. Almost all of the 255 reported recaptures with known locations (97%) were in the western Gulf of Maine, but four (2%) were recaptured in Canadian waters, and three (1%) were recaptured on Georges Bank. A large portion of recaptures (18%) were recaptured near the tagging location during the spawning season (May-July) and recaptures were reported near the spawning site up to six years later. The pattern of tag recaptures suggests spawning site fidelity (Zemeckis et al. 2014a), and demonstrates that cod form aggregations offshore of the spawning site before and after spawning in spring.

Hunt et al. (1999) tagged more than 22,000 cod in the region from 1984 to 1997, primarily on Georges Bank and Browns Bank and adjusted 2,400 tag recoveries for fishing patterns and reporting rates. They also summarized tagging on the eastern Scotian Shelf from 1978 to 1981 and concluded that there is little exchange between the eastern Scotian Shelf and the Gulf of Maine region. Most cod tagged on eastern Georges Bank were recaptured on eastern Georges Bank (54%), some moved to the Browns Bank and the western Scotian Shelf (34%), western Georges Bank (10%), the Great South Channel (1%) and the Gulf of Maine (1%), and no recaptures were reported on Nantucket Shoals or southern New England-Mid Atlantic. Most cod tagged on Browns Bank were recaptured on Browns Bank, the western Scotian Shelf, and the Bay of Fundy (62%), some moved to Georges Bank (12%), the Gulf of Maine (6%), the Great South Channel (1%), and Nantucket Shoals (1%), and no recaptures were reported in southern New England-Mid Atlantic. Clark and Emberley (2010) reanalyzed these data and showed that most movements from Browns to Georges Bank were from releases on western Browns Bank.

Howell et al (2008) tagged 27,772 cod in the western Gulf of Maine and reported 1,334 recaptures, adjusted by the relative number of recaptures in each area as a proxy for fishing effort. They reported concentrations in Ipswich and Massachusetts Bays in winter and spring associated with spawning, dispersal throughout the western Gulf of Maine after spawning and spawning site fidelity (i.e., multi-year recoveries on the spawning grounds) while remaining resident to the area and sedentary (mean rate of travel <0.2 km/day).

Clark and Emberley (2010) summarized results from tagging approximately 14,000 cod in the Bay of Fundy in 2001–2002 and approximately 6,000 cod off southwest Nova Scotia in 2003-2004. Cod tagged in the Bay of Fundy were mostly recaptured west of Browns Bank in the Gulf of Maine and Bay of Fundy, with relatively few returns on Georges Bank and in the western Gulf of Maine. They compared this recovery pattern with cod tagged east of Browns Bank, which were mostly recaptured on the Scotian Shelf with few recaptured west of Browns Bank.

Tallack (2009, 2011) summarized movement information from the Northeast Regional Cod Tagging Program, which tagged 114,467 cod from the Bay of Fundy to southern New England and reported 6,540 recaptures. Movement analyses accounted for tag loss and tagging-induced mortality and weighted releases and recaptures for resource, fishing, and reporting patterns. There was some residence within management units (e.g., Gulf of Maine, Georges Bank), but also considerable movement among areas, including extensive movement between the Great South Channel and western Gulf of Maine, and the Great South Channel and western Georges Bank, some mixing between the Bay of Fundy and offshore banks, movement between Georges Bank and the Scotian Shelf, but little movement from Georges Bank to inshore New England.

Loehrke (2014) analyzed recaptures of 2,572 cod tagged on spawning grounds during spawning seasons from the Northeast Regional Cod Tagging Program and the Massachusetts Marine Fisheries Institute. He analyzed both unweighted data and recaptures weighted by

approximations of local exploitation rates. Movement patterns varied among spawning groups, from sedentary (southern New England) to dispersive (eastern Georges Bank).

In addition to acoustic and archival tagging (described below), Zemeckis et al. (2017) tagged 2,368 spring spawning cod in Massachusetts Bay with conventional tags and reported recaptures of 223 cod (196 with location). Most recaptures were in the western Gulf of Maine, except for 12 (6%) that moved to the Great South Channel (521) and one (1%) that moved to coastal Maine (512). Almost half of the recaptures were during a subsequent spring spawning season and ten (5%) were within 6 km from the release position, indicating spawning site fidelity. Some were also recaptured at other spawning locations in Ipswich Bay and Massachusetts Bay during the spawning season, suggesting some mixing among spring spawning groups within the western Gulf of Maine.

In summary of published conventional tagging studies in the region:

- There is little movement of cod between the eastern Scotian Shelf and the Gulf of Maine region (including Browns Bank, the Bay of Fundy, Georges Bank and more southern waters), and there appears to be a distinct and persistent boundary off southeast Nova Scotia (McKenzie 1956; Hunt et al. 1999; Clark and Emberley 2010).
- There is little dispersal of cod from the Bay of Fundy (Halliday 1971; McKenzie 1956; Hunt and Neilson 1993; O'Brien and Worcester 2009; Tallack 2009, 2011), but recent tagging suggests some movement to the western Gulf of Maine, western Scotian Shelf and Georges Bank (Clark and Emberley 2010).
- Cod in the Gulf of Maine, including coastal Maine (Higgins 1933, 1934; Perkins et al. 1997) and the western Gulf of Maine (Higgins 1929; Wise and Jensen 1960; Howell et al. 2008; Liu et al. 2016; Zemeckis et al. 2017), are relatively sedentary with some movement to the south (Tallack 2009, 2011; Loehrke 2014).
- There is extensive movement from the Great South Channel to the western Gulf of Maine, with some movement to southern New England, Georges Bank and the western Scotian Shelf (Wise 1963; O'Brien and Worcester 2009; Tallack 2009, 2011; Loehrke 2014).
- There is extensive movement between eastern Georges Bank and the western Scotian Shelf, with little movement beyond 68°W (Higgins 1931; Templeman 1962; Wise and Jensen 1960; Wise 1963; Hunt et al. 1999; O'Brien and Worcester 2009; Tallack 2009, 2011, Loehrke 2014).
- There is extensive movement between Nantucket Shoals and the Mid Atlantic Bight (Smith 1902; Schroeder 1930; Wise 1958; Wise and Jensen 1960; Wise 1963, Loehrke 2014).

### *Review of Spawning Dynamics from Acoustic Tagging Studies*

Studying the spawning dynamics of Atlantic cod, including their behavior and spatial ecology, provides valuable information for investigating stock structure. For example, information about spawning site fidelity, residency on spawning sites, and connectivity among spawning sites provides insights into the mixing among spawning components and subpopulations, which is valuable for inclusion with conventional tagging data and other stock identification techniques as a part of an interdisciplinary approach to investigating stock structure. Acoustic telemetry is an excellent tool for studying cod spawning dynamics given the ability to track the movements of individual fish over multiple spatial and temporal scales without the reliance on recaptures and associated uncertainties (e.g., heterogeneous fishing patterns and reporting rates; tag shedding).

Several studies have applied acoustic telemetry to study cod spawning dynamics in the Gulf of Maine. For example, Siceloff and Howell (2013) investigated the spawning dynamics of

spring-spawning cod (n=26) in Ipswich Bay in 2006 using a combination of moored acoustic telemetry receivers and active tracking using a boat-mounted directional receiver. Individual cod utilized home ranges  $\leq 60 \text{ km}^2$  (mean =  $41 \text{ km}^2$ ) with a high degree of spatial and temporal overlap in the detection of multiple fish. Spawning activity was associated with specific humps and ridges, and the mean residence time of individual fish on the spawning grounds was 30 days (range = 8-53 days), primarily during May and June. The authors concluded that cod in the western Gulf of Maine aggregate around fine-scale bathymetric features, utilize relatively small areas during spawning, are highly mobile within these areas, and tend to move as a group.

Several studies examined cod spawning dynamics in Massachusetts Bay, including both spring-spawning and winter-spawning cod. Dean et al. (2014) tagged spring-spawning cod (n=70) with acoustic transmitters within the Spring Cod Conservation Zone (SCCZ) in 2010 and 2011. Cod movements were tracked with a Vemco Positioning System (VPS) that provided extremely fine-scale (e.g.,  $<10\text{m}$ ) position estimates of tagged cod while aggregated to spawn and identified sex-based and diel patterns in space use and aggregation behavior. Females remained aggregated in one small location during daytime with little variability within and between years. During daytime, males formed separate but adjacent aggregations over a larger area (Figure 18). At night, males sought out individual territories and females made periodic excursions to the male territories with spawning events appearing to occur at night (Figure 19). The mean residence time of cod on the spawning ground was 38 days with cod primarily resident from May through July. Cod exhibited multi-year spawning site fidelity (up to four consecutive years) with respect to this spawning site in the SCCZ, with 47 (95%) tagged individuals exhibiting spawning site fidelity after adjusting for fishing mortality, natural mortality, and skipped spawning (Zemeckis et al. 2014a). Spawning site fidelity serves as one of multiple mechanisms contributing to the formation and maintenance of the observed metapopulation structure of cod in U.S. waters by limiting the connectivity among subpopulations. However, acoustic telemetry detections and conventional tag recaptures also documented connectivity among spawning sites in Massachusetts Bay and Ipswich Bay, where some tagged fish were detected or recaptured at multiple spawning sites within the same spawning season (Zemeckis et al. 2017). Although there is a high rate of spawning site fidelity, there is also connectivity among inshore spawning sites via adult movements, which contributes to gene flow among spring-spawning components in the Gulf of Maine and is consistent with results from genetics studies (e.g., Kovach et al. 2010).

Zemeckis et al. (2019) described the spatial and temporal distribution of cod spawning during the winter in Massachusetts Bay using acoustic telemetry receivers deployed either at fixed locations or on mobile autonomous gliders. Tagged cod exhibited spawning site fidelity and spawning primarily occurred from early November through January. The spatial distribution of spawning was largely consistent during three years of monitoring and was concentrated in multiple hotspots in Massachusetts Bay and near the northwest corner of Stellwagen Bank in depths greater than 50 m. Results from this study demonstrate that there are multiple focal points of spawning during the winter in Massachusetts Bay and that there is some connectivity among these locations with fish tagged throughout the study site aggregating in multiple locations. Furthermore, results from this study confirmed findings from previous studies, where despite a disparity in spawning season between spring-spawning and winter-spawning cod in Massachusetts Bay, they utilize similar areas during their respective seasons.

## Methods & Materials

### *Residence and Movement Patterns from Conventional Tags*

Available data were analyzed to tabulate residence and movement among areas and regions to standardize information across tagging studies at a common spatial scale (statistical area) that is pertinent to management and assessment boundaries (Table 1). Data were available from logs keypunched from Schroeder (1930), two tagging studies by Canada Department of Fisheries and Oceans (DFO; Hunt et al. 1999, Clark and Emberley 2008), the Northeast Regional Cod Tagging Program (NERCTP; Tallack 2009, 2011), the Massachusetts Marine Fisheries Institute (MA MFI; Loehrke 2014), and the Massachusetts Spring Cod Conservation Zone (MA SCCZ; Zemeckis et al. 2017).

Table 1. Tagging data available for analysis of residence and dispersal patterns (including Appendix letter for results).

| Study          | Reference             | Release Area(s)              | Years     | Months  | Releases | Recaptures | App. |
|----------------|-----------------------|------------------------------|-----------|---------|----------|------------|------|
| Schroeder logs | Schroeder 1930        | all US areas                 | 1923-1927 | Jan-Oct | 30,149   | 2,150      | A    |
| DFO 1994       | Hunt et al. 1999      | Georges Bank & Gulf of Maine | 1994-1996 | Mar-Dec | 5,067    | 262        | B    |
| NERCTP         | Tallack 2011          | all areas                    | 2002-2003 | Jan-Dec | 114,473  | 6,784      | C    |
| MA MFI         | Loehrke 2014          | all US areas                 | 2000-2014 | Jan-Dec | 37,460   | 1,900      | D    |
| DFO 2001-2004  | Clark & Emberley 2008 | Scotian Shelf                | 2001-2004 | Jan-Dec | 10,000   | 472        | E    |
| MA SCCZ        | Zemeckis et al. 2017  | Massachusetts Bay            | 2010-2013 | Apr-Jul | 2,368    | 223        | F    |
|                |                       |                              |           | Totals  | 199,517  | 11,791     | G    |

Schroeder's logs include tag releases by the U.S. Bureau of Fisheries in the 1920s. Cod were caught with hook gear in less than 50 fathoms, and those in good condition were tagged on the caudal fin with uniquely numbered metal crimps (Schroeder 1930). Many of the records in Schroeder's logs were keypunched by NEFSC, but logbook 3 is missing, and logbooks 11-12 have not been keypunched. (Michael Palmer, personal communication). Schroeder (1930) summarizes results for 24,739 cod tagged from the Great South Channel to New Jersey 1923-1929, but the keypunched logs include 30,149 releases from the Gulf of Maine to southern New England, 1923-1927.

Canada DFO provided two cod tagging datasets for releases on Georges Bank in 1994-1996 (included in Hunt et al. 1999) and for cod tag releases on the Scotian Shelf 2001-2004 (reported by Clark and Emberley 2008). Cod were captured with short trawl tows, and viable cod were tagged with T-bar tags at the base of the first dorsal fin (Hunt et al. 1999).

As reported in detail by Tallack (2009, 2011), the NERCTP tagged cod (T-bar tags at the base of the dorsal fin) throughout New England and the Bay of Fundy. Each tagging organization targeted fishing grounds which have been traditionally considered key spawning or feeding grounds or were considered important for studying movement of Atlantic cod. Cod tagging trips took place year-round from March 2003 through July 2005, with peak tagging seasons in spring



and autumn of each year. Outreach for reporting tag recoveries included shirts, hats, lottery reward, and high reward tags.

The Massachusetts Marine Fisheries Institute (MFI) targeted spawning groups and adopted the same tagging protocol as the NERCTP (Loehrke 2014). Spawning cod were tagged with T-bar tags from the western Gulf of Maine, the Great South Channel and Nantucket Shoals, Georges Bank, and southern New England. Zemeckis et al. (2017) tagged spawning cod in spring in Massachusetts Bay with T-bar tags.

Spatial stratification was based on statistical areas for reporting fishing effort and catch (Figure 1). Reporting conventions and reporting area boundaries were consolidated and standardized to reflect major fishing grounds (Rounsefell, 1948; Halliday and Pinhorn, 1990). Statistical areas were also grouped into regions that reflect putative spawning groups, as identified in Chapters 2 and 3 (genetics and early life history).

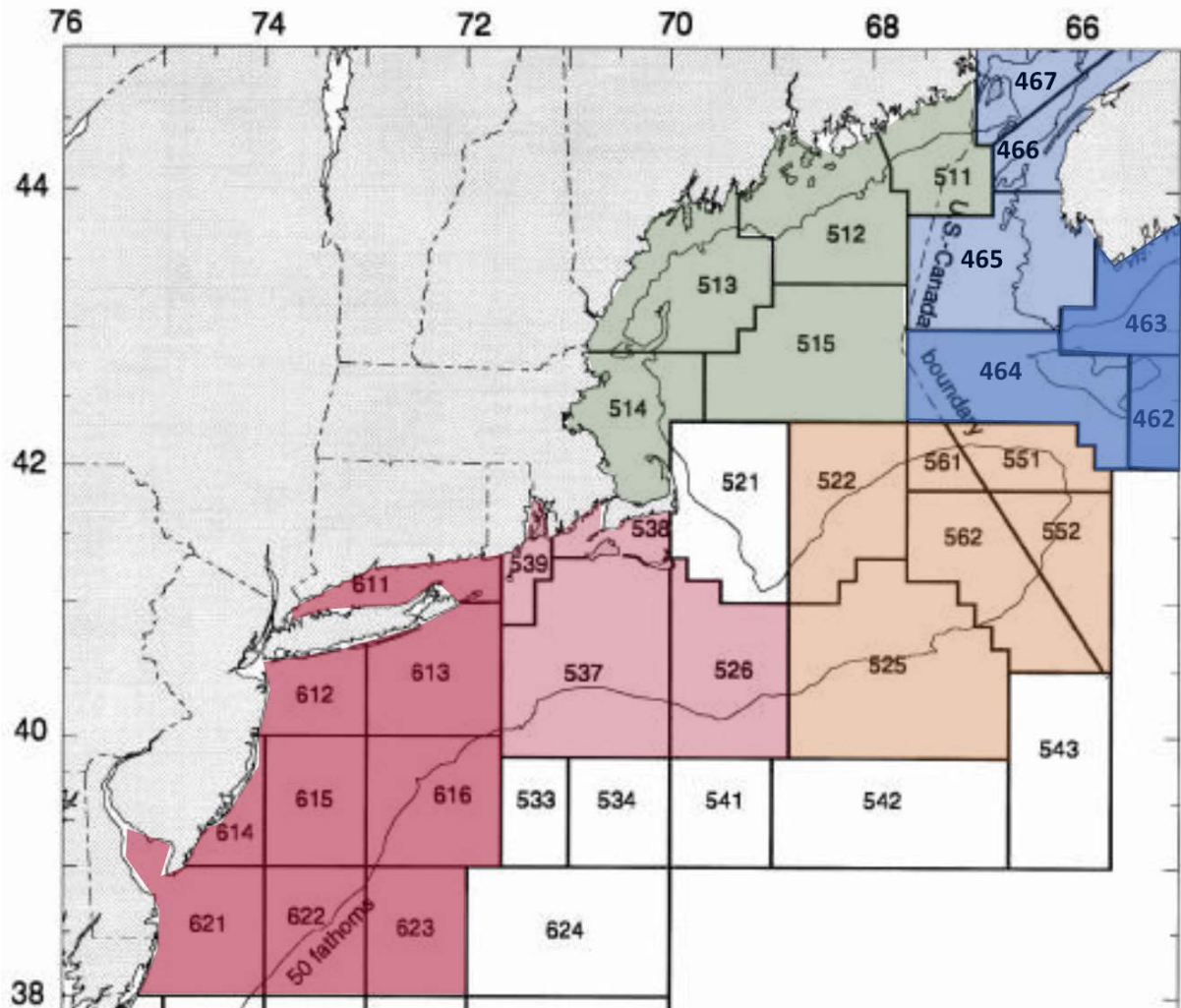


Figure 1. Spatial stratification based on statistical areas for reporting fishing effort and catch (dark blue: eastern Scotian Shelf; medium blue: Browns Bank; light blue: Bay of Fundy; green: Gulf of Maine; white: Great South Channel; orange: Georges Bank; red: S. New England-Mid-Atlantic).

Matrices of residence and movement were compiled from release and recapture records that included tag release date and location, fish size at release, and recapture date and location.

Matrices were derived separately in two ways: 1) for all recaptures (with known location), and 2) for recaptures of fish tagged during the spawning season, on the spawning grounds. Spawning seasons and areas were revised from those defined by Loehrke (2014), as identified in Chapters 2, 3 and 7 (genetics, early life history and Fishermen's Ecological Knowledge), recognizing that some of these areas have multiple persistent spawning locations:

- Western Gulf of Maine Winter Spawners (513-514, Oct-Jan)
- Western Gulf of Maine Spring Spawners (513-514, Apr-Jul)
- 'Cape Cod' (521, 526; Oct-Jan)
- Eastern Georges Bank (522,551,552,561,562; Dec-May)
- Western Scotian Shelf-Bay of Fundy (466-467, Jan-May)
- Southern New England (537, 539; Nov-Mar)

Recaptures of each spawning group were compiled by seasonal period to indicate spawning site fidelity and post-spawning dispersal: 1) spawning season of release, 2) post-spawning seasons (i.e., recaptures during months when spawning does not occur for each group), and 3) subsequent spawning seasons (e.g., recaptures during spawning months and after at least one post-spawning season). Recapture patterns were depicted with bag plots (Rousseeuw et al. 1999), which are bivariate extensions of box plots, including a polygon that encompasses 50% of the data, an outer 'fence' which approximates a 95% confidence region, and statistical outliers, as applied to cod tagging data by Loehrke (2014). Bag plots were presented by season for spawning groups with >50 recaptures per season.

Residence and dispersal matrices were derived for each study, and for all studies combined, except for the Schroeder logs from the early 1900s, which indicated some differences in cod distribution, fishing effort and movement patterns.

Recapture data were not adjusted for patterns of local fishing effort, because estimates of catch and effort by statistical area are uncertain, some estimates of fishing mortality may be unreliable (e.g., Georges Bank; NEFSC 2017), and previous efforts to adjust tagging data have produced similar results as unweighted data (Tallack 2009, 2011; Loehrke 2014). Therefore, attempts to adjust tagging data for fishing patterns may introduce more uncertainty (Loehrke 2014).

### *Habitat Occupancy and Movements from Archival Tagging*

Archival data storage tags (DSTs) record data on the environmental conditions experienced by tagged animals, including variables such as depth, temperature, and salinity. DSTs can be externally-attached or surgically implanted, and they need to be physically recovered to download the environmental data archived on the tags. Geolocation involves the estimation of daily positions via a likelihood model that compares the environmental data recorded by the tags with oceanographic model predictions and inclusion of an animal movement model. Therefore, DSTs provide semi-fishery-independent data on animal movements, because they need to be physically recovered (i.e., typically by fishermen) but geolocation yields movement data from the entire period during which an animal is at-liberty (in comparison to conventional tagging where only release and recapture locations are known). Combining estimated daily positions into the most probable track while at-liberty permits investigation of migration patterns and space use, which are valuable for examining stock structure and mixing among subpopulations.

Spring-spawning cod in Ipswich Bay were tagged with DSTs in 2006 (n=200) (Siceloff 2009; Siceloff and Howell 2013). Data from DSTs recovered as a part of this study were used to investigate cod habitat occupancy and off-bottom movements, as well as to infer movements based

on comparisons with environmental and bathymetry data in the region. However, recovered DSTs from this study were not included in geolocation analyses.

Spring-spawning cod were also tagged with DSTs (n=266) in the Spring Cod Conservation Zone (SCCZ) in Massachusetts Bay from 2010-2014 (Zemeckis 2016; Zemeckis et al. 2017). The depth and temperature data from the DSTs were used to investigate seasonal habitat occupancy. Recovered DST data were also used in geolocation analyses that assigned daily position estimates to statistical areas. This geolocation method relied on depth and temperature data from the DSTs with tidal-based exclusion and an observational likelihood model with movement constraints and activity level classifications (Zemeckis 2016; Zemeckis et al. 2017). The observational model compared the depth, bottom water temperature, and tidal information from the DSTs with estimates from the Northeast Coastal Ocean Forecasting System (NeCOFS 2013), which is based on the Finite-Volume Community Ocean Model (FVCOM: Chen et al. 2006). The statistical area with the greatest score of likelihood was chosen as the most likely daily position for a given fish with the consideration of movement constraints based on cod behavior, physiology (i.e., swimming capabilities), and geolocation limitations. To investigate movement patterns, assignments to statistical areas were grouped among all individuals and summarized by seasonal period.

Additional DST tagging was conducted throughout U.S. waters from 2001-2011, December-April by the Massachusetts Marine Fisheries Institute (MFI; Liu 2019). DSTs were released in the Gulf of Maine, Great South Channel and Nantucket Shoals, and Southern New England. Depth and temperature data recorded by the DSTs were used to describe the seasonal habitat occupancy of cod tagged in each region. A subset of the DST data recovered as a part of this long-term effort to understand cod movement patterns and stock structure were analyzed by Gröger et al. (2007) who employed a tidal-based algorithmic geolocation method to estimate daily positions using a direct comparison of environmental data from the DSTs with oceanographic model predictions. Data from recovered DSTs analyzed by Gröger et al. (2007) were combined with that from the larger dataset of DSTs recovered as a part of the MFI tagging efforts and geolocated using a hidden Markov model (HMM) developed by Liu et al. (2017). The HMM framework from Liu et al. (2017) contains a likelihood model that compares tag-recorded environmental data (depth, temperature, tidal characteristics) with those derived from an oceanographic model and a behavior model that constrains the horizontal movement of the fish in order to estimate the most likely daily location. The most probable track was then selected as that which maximizes the overall probability score of the whole sequence of daily locations while the fish was at-liberty. For each of the three tagging regions, the most probable track for each fish was plotted and the probability distributions from all fish were pooled as an estimate of the utilization distribution (based on the methods of Galuardi and Lutcavage, 2012) for each group to estimate core use areas (Liu 2019).

## Results

### *Residence and Movement patterns from Conventional Tags*

Nearly all cod tagged and released in each study were expected to be sexually mature (Figure 2).

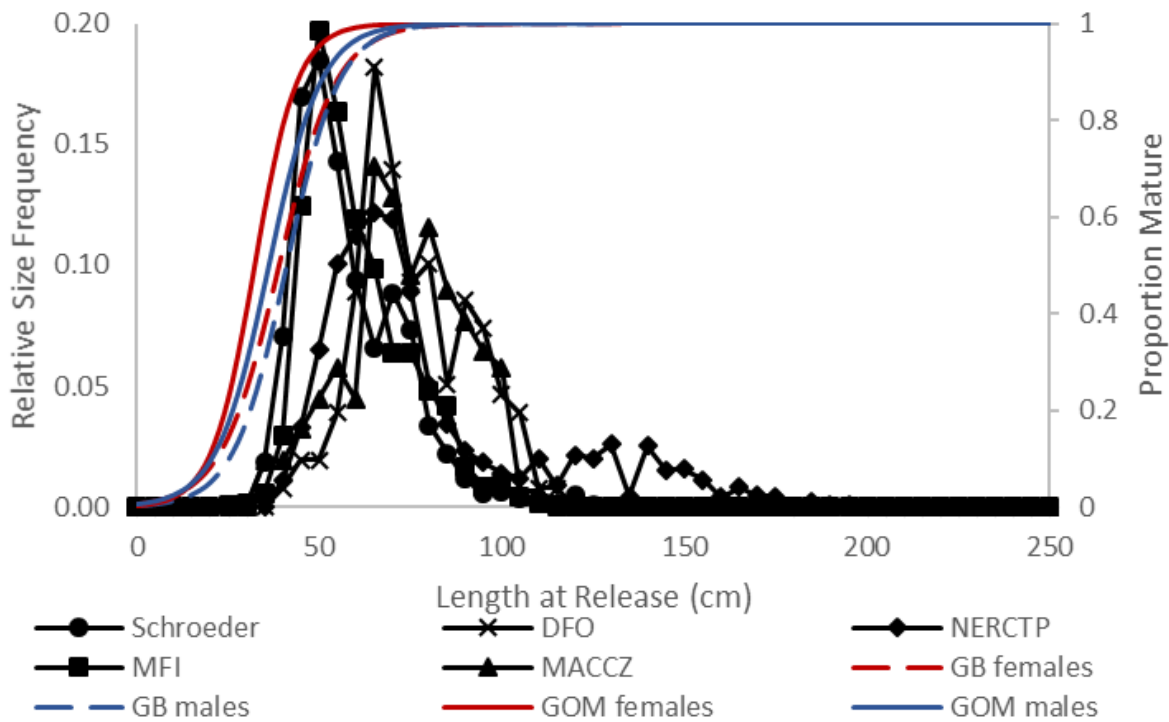


Figure 2. Size frequency of cod tagged and recaptured in the Northeast Regional Cod Tagging Program (release size, black line) and estimates of maturity at size (colored lines) from O'Brien et al. (1993).

The summary of all recaptures by statistical area indicates high regional residence as well as some substantial regional movements (Table 2, Figure 3, Appendix G), similar to those reported by Tallack (2009, 2011). There were 8,351 reported recaptures with a reliable recapture position. Regional residence was generally high, but there were also some substantial regional movements (>10%, Table 2). There was 93% residence in the Bay of Fundy-western Scotian Shelf (462, 463, 464, 465, 466, 467), 92% residence in the Gulf of Maine (511, 512, 513, 514, 515), 69% residence in the Great South Channel (521, with substantial movement to the Gulf of Maine), 76% residence on Georges Bank (522, 525, 551, 552, 561, 562, with substantial movement to Browns Bank), 88% residence in southern New England (526, 537, 539), and 100% residence in the Mid-Atlantic Bight (621, 625, 626).

Table 2. Proportion of tag recaptures from multiple tagging studies (Table 1, Hunt et al. 1999, Tallack 2011, Loehrke 2014, Clark and Emberley 2008, Zemeckis et al. 2017) by region of release and recapture (colors indicate relative proportion).

| Release Area                 | Recapture Area |      |      |      |      |
|------------------------------|----------------|------|------|------|------|
|                              | BOF            | GOM  | GSC  | EGB  | SNMA |
| Bay of Fundy-W Scotian Shelf | 0.93           | 0.03 | 0.00 | 0.04 | 0.00 |
| Gulf of Maine                | 0.02           | 0.92 | 0.03 | 0.02 | 0.01 |
| Great South Channel          | 0.00           | 0.17 | 0.69 | 0.08 | 0.04 |
| eastern Georges Bank         | 0.19           | 0.02 | 0.03 | 0.76 | 0.00 |
| S. New England-Mid Atlantic  | 0.00           | 0.01 | 0.08 | 0.01 | 0.92 |

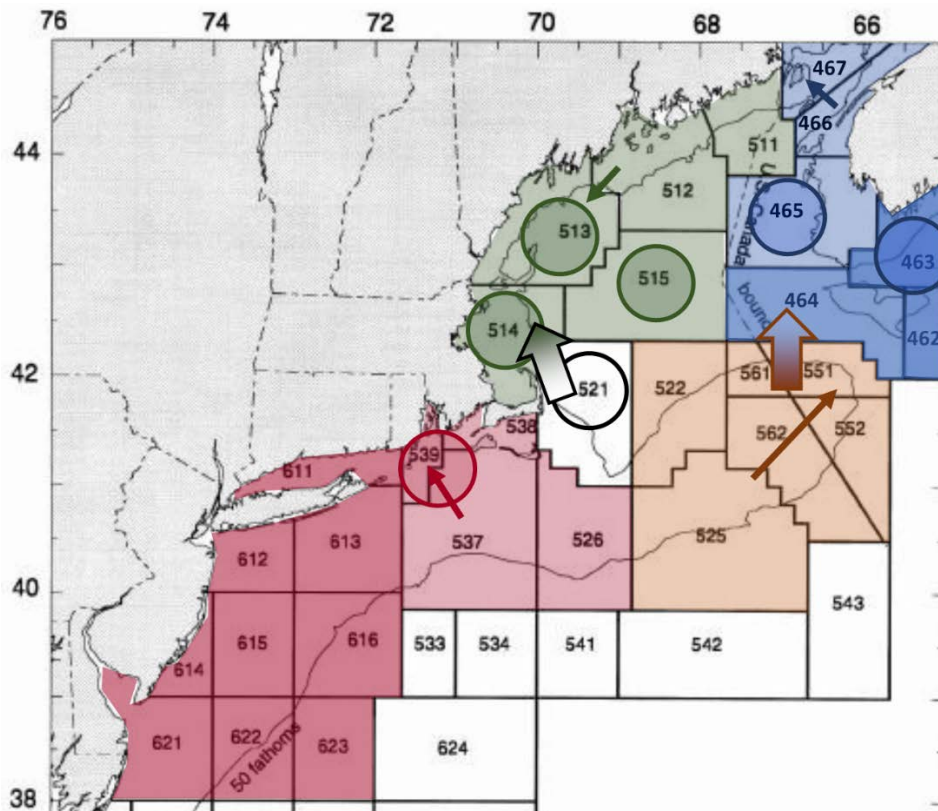


Figure 3. Major patterns of movement among regions (multicolor arrows: >10% movement), movement within regions (solid colored arrows: >50% movement from statistical area), and residence within statistical areas (circles: >50% residence in statistical area) from combined tagging studies.

Residence within and movement between individual statistical areas (Appendix Table G1) were similar to those generalized by Tallack (2011) and others. Residence and movement from statistical areas indicates >50% residence on the western Scotian Shelf (463), the southern Bay of Fundy (465), southern ME-NH (513), southwest Gulf of Maine (514), central Gulf of Maine (515), Great South Channel (521), RI Sound (539) and off Delaware (621). Substantial

movement (>50%) was from the northeast Bay of Fundy (466) to the northwest Bay of Fundy (467), from mid-coast ME (512) to southern ME-NH (513), from southwest Georges Bank (525) to northeast Georges Bank (551), and from offshore southern New England (537) to RI Sound (539) and from off MD (625, 626) to off DE (621). Although the number of tag releases from eastern ME were limited, more were recaptured in the Bay of Fundy than in other areas of the Gulf of Maine (Appendix Table G1).

Western Gulf of Maine winter spawners demonstrated strong spawning site fidelity (Table 3). Nearly all (99%) of recaptures during the same release season (95 with reported recapture location) were recaptured in the spawning area (513-514, western Gulf of Maine). Of the 290 recaptures with known recapture position in the post-spawning period, 93% were in the spawning area, and 6% moved to the Great South Channel (521), Georges Bank (522, 562) and southern New England (537, 538). In subsequent spawning seasons there was 93% residence in the Gulf of Maine, 92% residence in spawning area, 2% movement to central Gulf of Maine (515), and 6% movement to the Great South Channel and southern New England. Distribution of winter spawning cod was concentrated in the western Gulf of Maine during the spawning season (Figure 4) and distributed more broadly during the post-spawning season (Figure 5).

Table 3. Recaptures from combined tagging studies (Tallack 2011, Loehrke 2014) of cod tagged during the winter spawning season (October-January) in the western Gulf of Maine (513-514) and recaptured during the same spawning season of release, the post-spawning season (February-September) and subsequent spawning seasons. Colors indicate relative proportions.

|                     | Browns Bank | western Gulf of Maine | central Gulf of Maine | Great South Channel | eastern Georges Bank | southern New England |
|---------------------|-------------|-----------------------|-----------------------|---------------------|----------------------|----------------------|
| Release             | 0.00        | 0.99                  | 0.01                  | 0.00                | 0.00                 | 0.00                 |
| Post-spawning       | 0.00        | 0.93                  | 0.01                  | 0.02                | 0.02                 | 0.02                 |
| Subsequent Spawning | 0.00        | 0.92                  | 0.02                  | 0.03                | 0.00                 | 0.03                 |

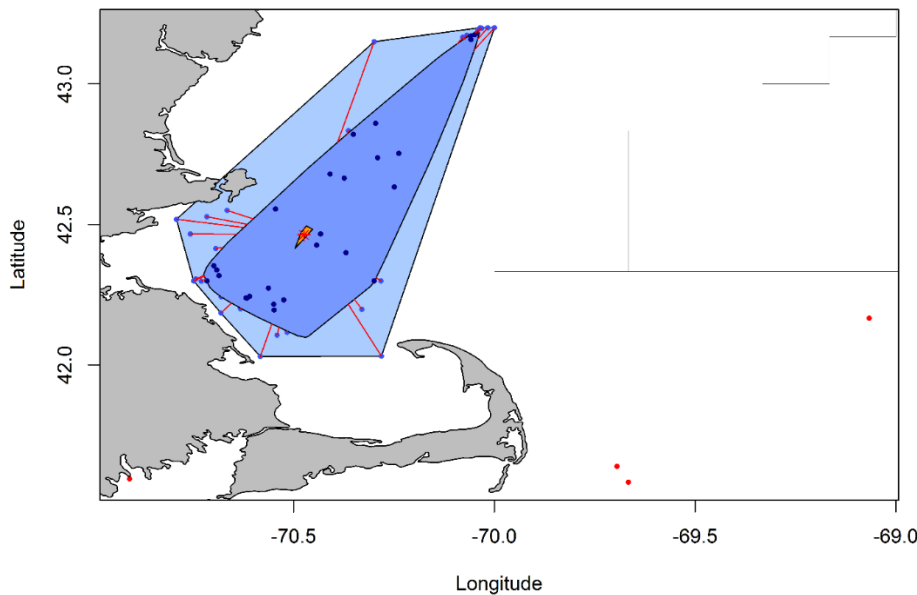


Figure 4. Recaptures of western Gulf of Maine winter-spawning cod during the spawning season (October-January), with median recapture position (red asterisk), area with 50% of recaptures (dark blue), approximately 95% of recaptures (light blue) and outliers (red dots).



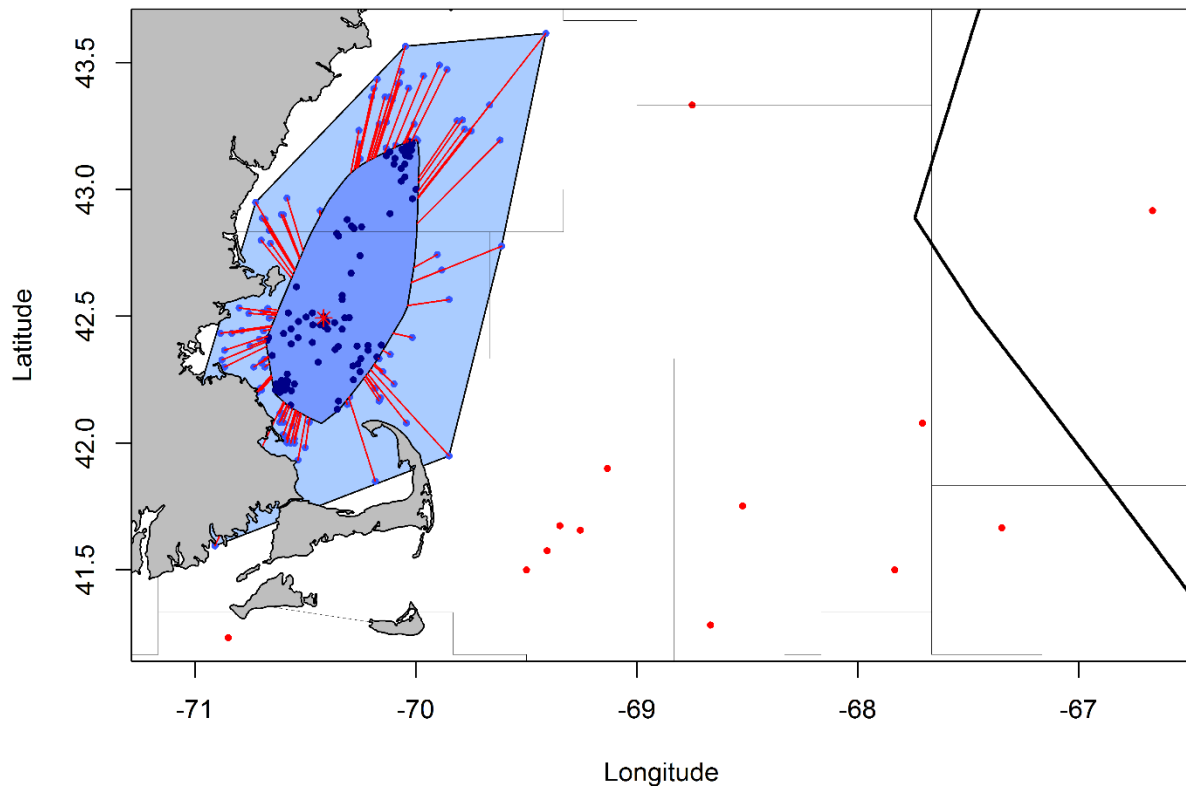


Figure 5. Recaptures of western Gulf of Maine winter-spawning cod during the post-spawning season (February-September), with median recapture position (red asterisk), area with 50% of recaptures (dark blue), approximately 95% of recaptures (light blue) and outliers (red dots).

Western Gulf of Maine spring spawners also demonstrated high spawning site fidelity (Table 4). Of the 1036 recaptures during the same release season with known recapture location, there was 97% residence in spawning area (513-514, western Gulf of Maine), and 2% movement to Great South Channel (521). There were 1138 recaptures with reported recapture location during the post-spawning season, with 91% residence in spawning area, 5% movement to the Great South Channel (521), 1% to central Gulf of Maine (515), 1% to Georges Bank (522, 525, 551, 561) and 2% to southern New England (526, 538). Similar to the results reported by Loehrke (2012) and Zemeckis et al. (2017), the 501 cod recaptured in subsequent spawning seasons with location information had 95% residence in the spawning area, 1% movement central Gulf of Maine (515; 96% residence in the Gulf of Maine), 2% to Great South Channel (521), and 2% to Georges Bank (522, 525, 551, 561). Most recaptures of spring-spawning cod from the western Gulf of Maine were recaptured in the western Gulf of Maine, with some overlap with the great South Channel during both the spawning and post-spawning seasons (Figures 6-7).

Table 4. Recaptures from combined studies (Tallack 2011, Loehrke 2014, Zemeckis et al. 2017) of cod tagged during the spring spawning season (April-July) in the western Gulf of Maine (513-514) and recaptured during the same spawning season, the post-spawning season (August-March) and subsequent spawning seasons. Colors indicate relative proportions.

|                     |        | western | central | Great   | eastern | southern |
|---------------------|--------|---------|---------|---------|---------|----------|
|                     | Browns | Gulf of | Gulf of | South   | Georges | New      |
| Season of Recapture | Bank   | Maine   | Maine   | Channel | Bank    | England  |
| Release             | 0.00   | 0.97    | 0.00    | 0.02    | 0.00    | 0.00     |
| Post-spawning       | 0.00   | 0.91    | 0.01    | 0.05    | 0.01    | 0.02     |
| Subsequent Spawning | 0.00   | 0.95    | 0.01    | 0.02    | 0.02    | 0.00     |

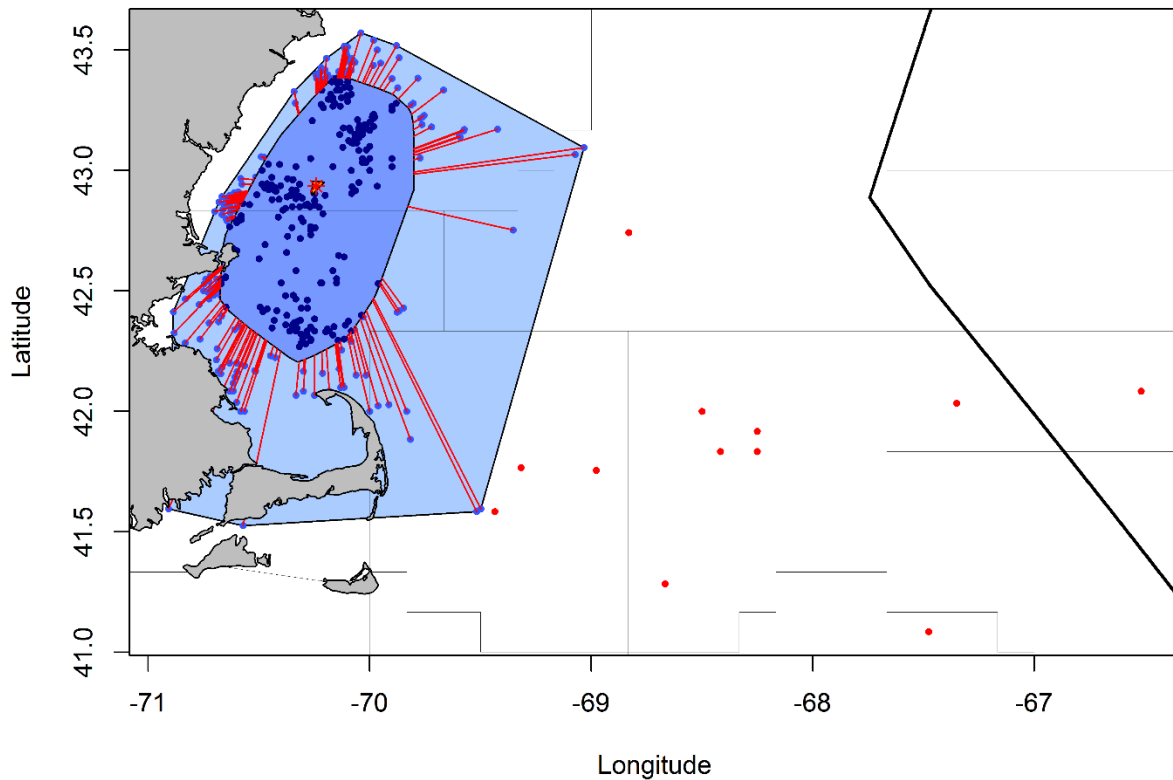


Figure 6. Recaptures of western Gulf of Maine spring-spawning cod during the spawning season, with median recapture position (red asterisk), area with 50% of recaptures (dark blue), approximately 95% of recaptures (light blue) and outliers (red dots).



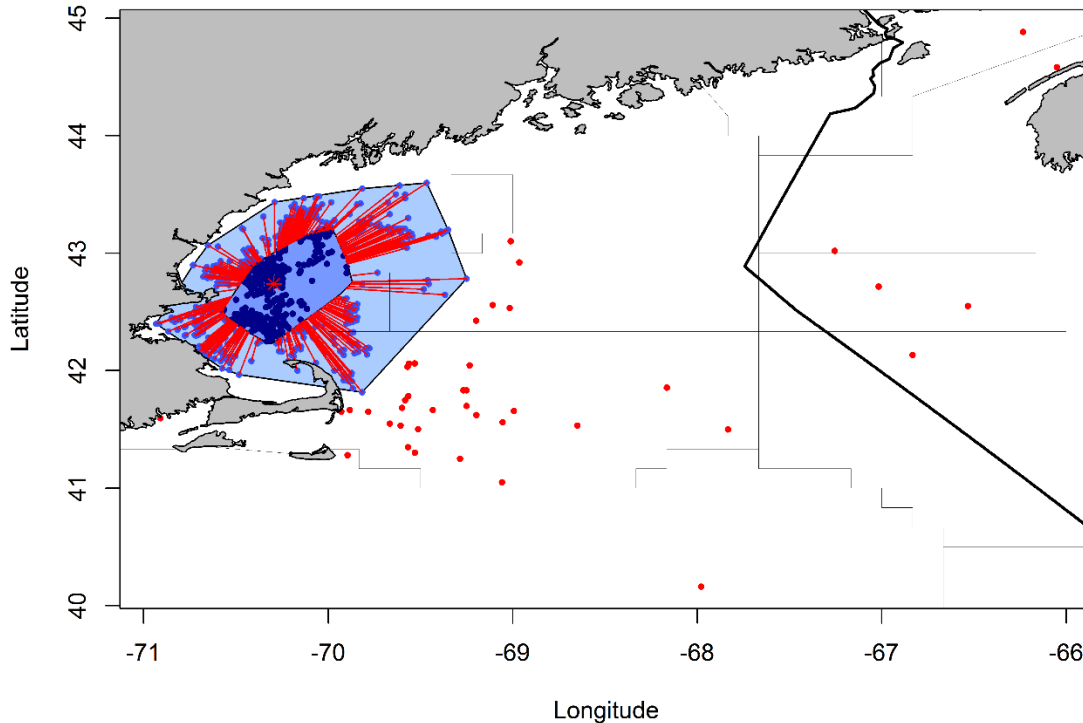


Figure 7. Recaptures of western Gulf of Maine spring-spawning cod during the post-spawning season, with median recapture position (red asterix), area with 50% of recaptures (dark blue), approximately 95% of recaptures (light blue) and outliers (red dots).

Eastern Georges Bank spawners demonstrated high spawning site fidelity and dispersal in the post-spawning season (Table 5). During the release season (183 recaptures with locations) there was 96% residence on eastern Georges Bank (522, 525, 551, 552, 561, 562), 2% movement to the western Scotian Shelf and Bay of Fundy (464, 465), 1% movement to the western Gulf of Maine (513, 514), and 1% to the Great South Channel (521). During the post-spawning season (746 recaptures with locations), there was 70% residence on eastern Georges Bank (522, 525, 551, 552, 561, 562), 26% movement to the Scotian Shelf-Bay of Fundy (461, 462, 463, 464, 465, 466, 467), 3% movement to the Great South Channel (521), and 2% movement to the Gulf of Maine (511, 512, 513, 514, 515). During subsequent spawning seasons (274 recaptures with locations), there was 72% residence on eastern Georges Bank, 22% movement to the Scotian Shelf-Bay of Fundy (461, 462, 463, 464, 465, 466), 3% movement to the Great South Channel (521), 2% movement to the Gulf of Maine (511, 514), and 2% movement to Nantucket Shoals (526). The majority of recaptures of eastern Georges Bank spawners were on eastern Georges Bank, Browns Bank and the western Scotian Shelf during the spawning season (Figure 8) and mostly in Canadian waters during the post-spawning season (Figure 9).

Table 5. Recaptures from combined tagging studies (Hunt et al. 1999, Tallack 2011) of cod tagged during the spawning season (December-May) on eastern Georges Bank (522, 551, 552, 561, 562) and recaptured during the same spawning season, the post-spawning season (June-November) and subsequent spawning seasons. Colors indicate relative proportions.

|                     | W. Scotian<br>Shelf-Bay<br>of Fundy | Gulf of<br>Maine | Great<br>South<br>Channel | eastern<br>Georges<br>Bank | southern<br>New<br>England |
|---------------------|-------------------------------------|------------------|---------------------------|----------------------------|----------------------------|
| Release             | 0.02                                | 0.01             | 0.01                      | 0.96                       | 0.00                       |
| Post-spawning       | 0.26                                | 0.02             | 0.03                      | 0.70                       | 0.00                       |
| Subsequent Spawning | 0.22                                | 0.02             | 0.03                      | 0.72                       | 0.01                       |

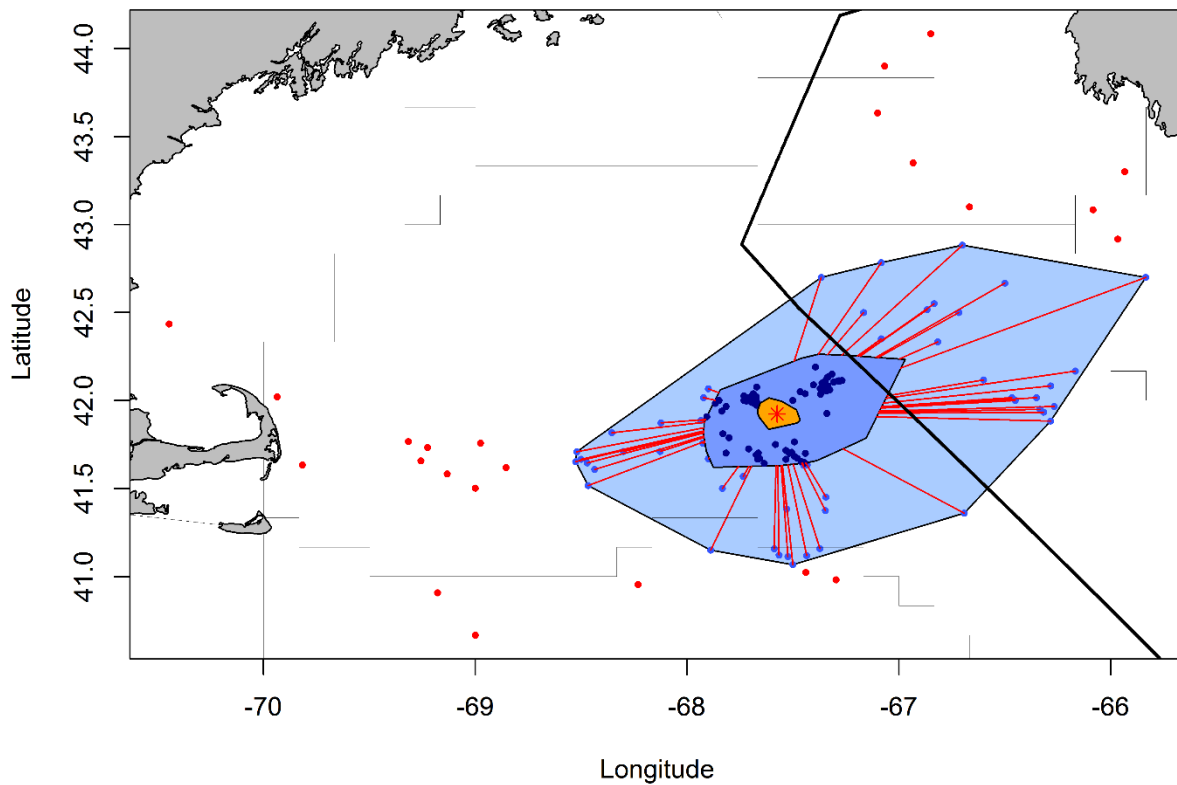


Figure 8. Recaptures of eastern Georges Bank spawning cod during the spawning season, with median recapture position (red asterisk), area with 50% of recaptures (dark blue), approximately 95% of recaptures (light blue) and outliers (red dots).

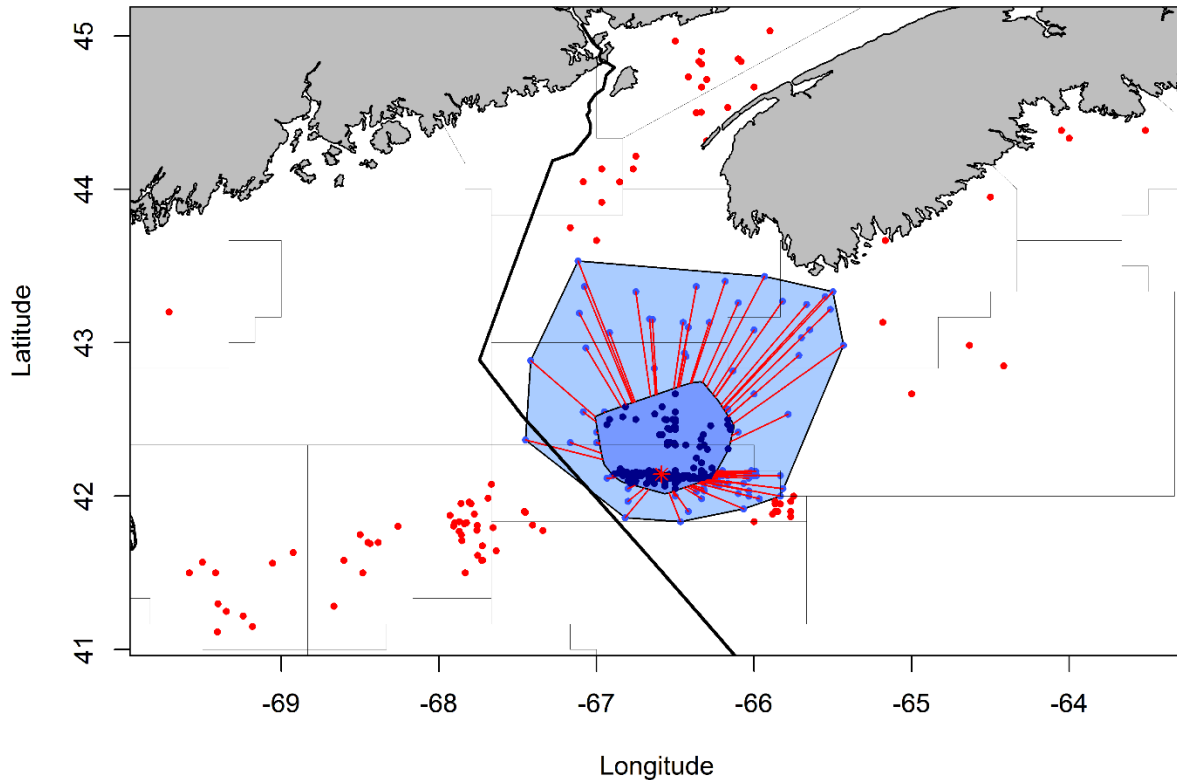


Figure 9. Recaptures of eastern Georges Bank spawning cod during the post-spawning season, with median recapture position (red asterisk), area with 50% of recaptures (dark blue), approximately 95% of recaptures (light blue) and outliers (red dots).

Western Scotian Shelf-Bay of Fundy spawners demonstrated high spawning site fidelity (Table 6). There was 100% residence in the spawning area (463, 464, 465, 466, 467) during the release season (146 recaptures with locations), as well as 100% residence in the Bay of Fundy (466, 467). During the post-spawning season (503 recaptures with locations), there was 94% residence in the spawning area, 4% movement to Georges Bank (522, 551) and 2% movement to the Gulf of Maine (511, 513). During subsequent spawning seasons (168 recaptures with locations), there was 92% residence in the spawning area, 5% to Georges Bank (522, 551, 561), 3% movement to the Gulf of Maine (511, 513), and 1% to Mid Atlantic (621, off DE-MD). Much of the 2000-2002 tagging (Clark and Emberley 2008) was in area 465 (southwest Scotian Shelf, between Browns Bank and German Bank), in a fishery near at the boundary of the Bay of Fundy, Browns Bank and the Scotian Shelf. Most of the recaptures of spawning cod tagged in the Western Scotian Shelf-Bay of Fundy stayed in the spawning area during the spawning season (Figure 10) and mostly in the Bay of Fundy during the post-spawning season (Figure 11).

Table 6. Recaptures from combined tagging studies (Clark and Emberley 2008, Tallack 2011) of cod tagged during the spawning season (January-May) in the Bay of Fundy (466-467) and recaptured during the same spawning season, the post-spawning season (June-December) and subsequent spawning seasons. Colors indicate relative proportions.

| Season of Recapture | W. Scotian Shelf-Bay of Fundy | Gulf of Maine | eastern Georges Bank | Mid-Atlantic Bight |
|---------------------|-------------------------------|---------------|----------------------|--------------------|
| Release             | 1.00                          | 0.00          | 0.00                 | 0.00               |
| Post-spawning       | 0.94                          | 0.02          | 0.04                 | 0.00               |
| Subsequent Spawning | 0.92                          | 0.03          | 0.05                 | 0.01               |

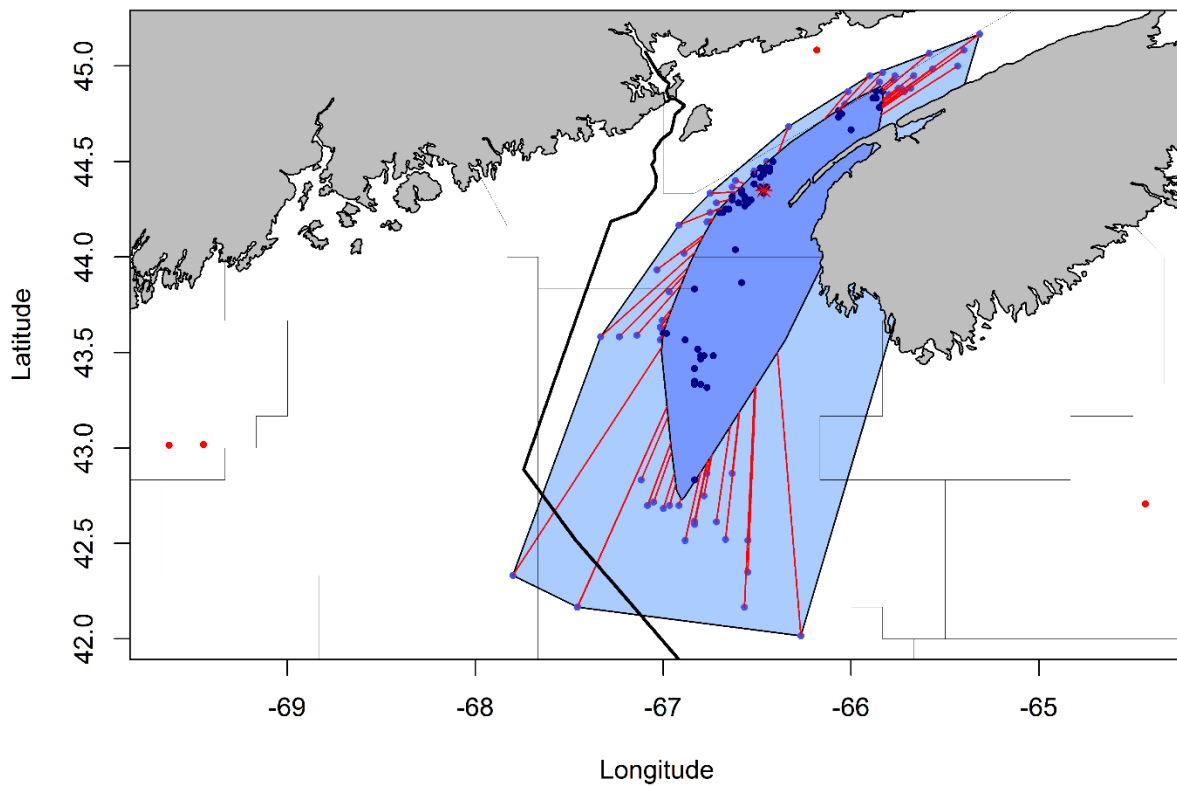


Figure 10. Recaptures of western Scotian Shelf and Bay of Fundy spawning cod during the spawning season, with median recapture position (red asterix), area with 50% of recaptures (dark blue), approximately 95% of recaptures (light blue) and outliers (red dots).

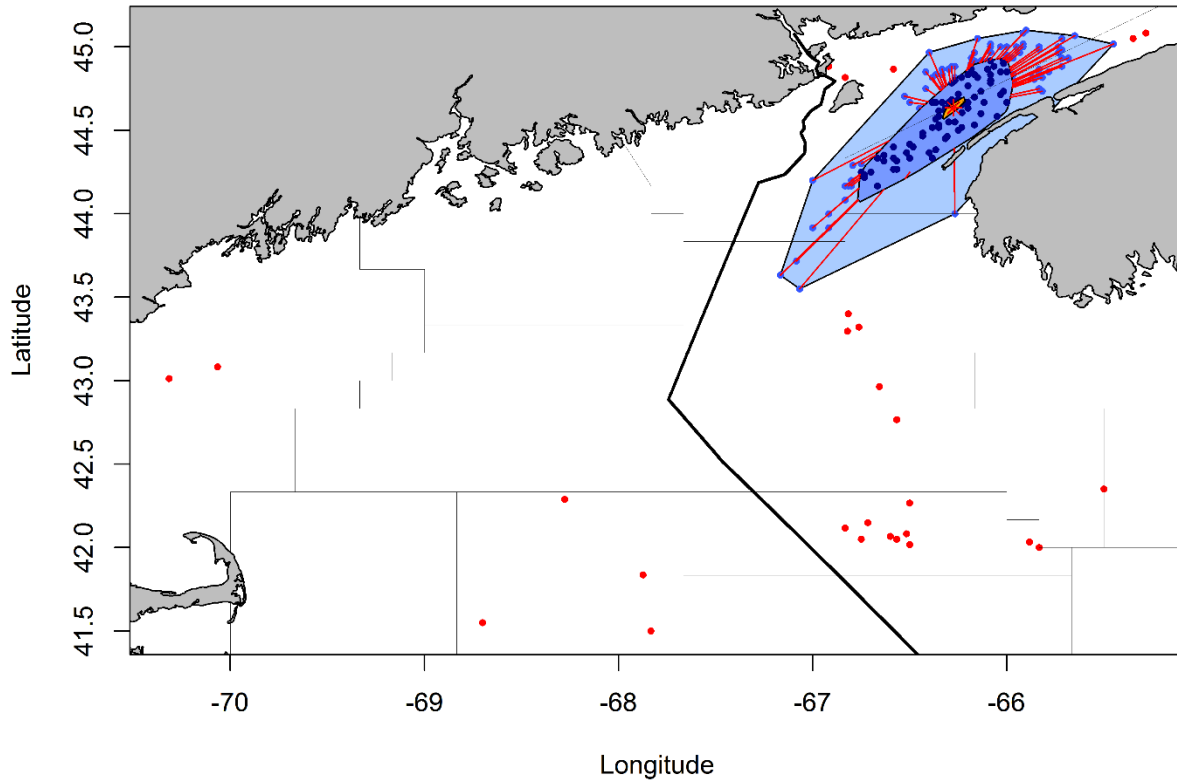


Figure 11. Recaptures of western Scotian Shelf and Bay of Fundy spawning cod during the post-spawning season, with median recapture position (red asterix), area with 50% of recaptures (dark blue), approximately 95% of recaptures (light blue) and outliers (red dots).

Cape Cod spawners demonstrated less residence and greater dispersal (Table 7), similar to the results reported by Wise (1963), Tallack (2009, 2011), and Loehrke (2014). During the release season (57 recaptures with locations), there was 84% residence in the spawning area (521-526, Great South Channel-Nantucket Shoals), 7% movement to southwestern Gulf of Maine (514), 7% to eastern Georges Bank (522, 551, 561), and 2% movement to the Mid Atlantic Bight (616, Hudson Canyon). During the post-spawning season (348 recaptures with locations), there was 65% residence in spawning area, 21% movement to the Gulf of Maine (513, 514, 515), 11% to eastern Georges Bank (522, 525, 551, 561), 3% to southern New England (537, 538, 539), and 1% to the Mid Atlantic Bight (612, 613, off Long Island). During subsequent spawning seasons (68 recaptures with locations), there was 59% residence in the spawning area, 28% movement to the western Gulf of Maine (513, 514), 6% to Georges Bank (522, 525, 551), 4% to southern New England (537, 538, 539), 1% to the Mid Atlantic Bight (612 off Long Island), and 1% to Browns Bank (464). Most Cape Cod spawners were recaptured in the Great South Channel and western Gulf of Maine during both the spawning and post-spawning seasons, with some movement to Georges Bank during the post-spawning seasons (Figure 13).

Table 7. Recaptures from the Northeast Regional Cod Tagging Program of cod tagged during the spawning season (October-January) in the ‘Cape Cod’ area (521) and recaptured during the same spawning season, the post-spawning season (February-September) and subsequent spawning seasons. Colors indicate relative proportions.

| Season of Recapture | Browns Bank | Gulf of Maine | Nantucket Shoals-Gt. S. Channel | Georges Bank | Southern New England | Mid Atlantic Bight |
|---------------------|-------------|---------------|---------------------------------|--------------|----------------------|--------------------|
| Release             | 0.00        | 0.07          | 0.84                            | 0.07         | 0.00                 | 0.02               |
| Post-spawning       | 0.00        | 0.21          | 0.65                            | 0.11         | 0.03                 | 0.01               |
| Subsequent Spawning | 0.01        | 0.28          | 0.59                            | 0.06         | 0.04                 | 0.01               |

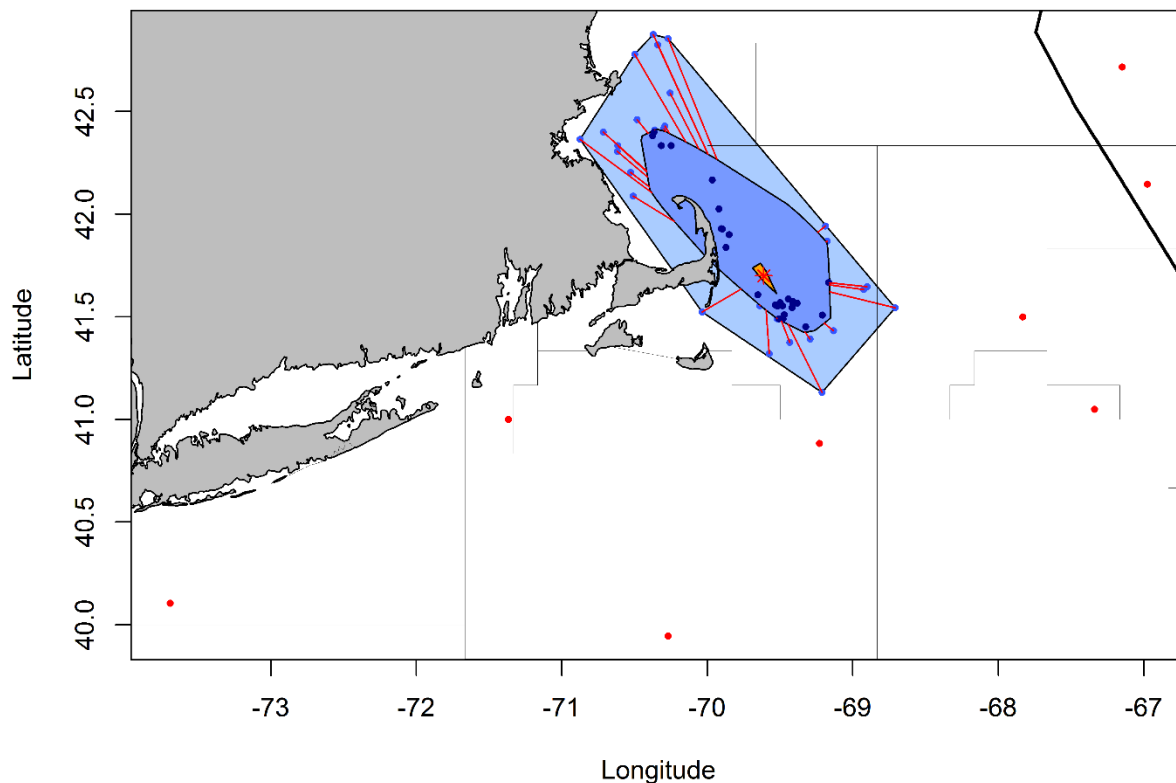


Figure 12. Recaptures of spawning cod tagged in the Cape Cod area during the spawning season, with median recapture position (red asterisk), area with 50% of recaptures (dark blue), approximately 95% of recaptures (light blue) and outliers (red dots).

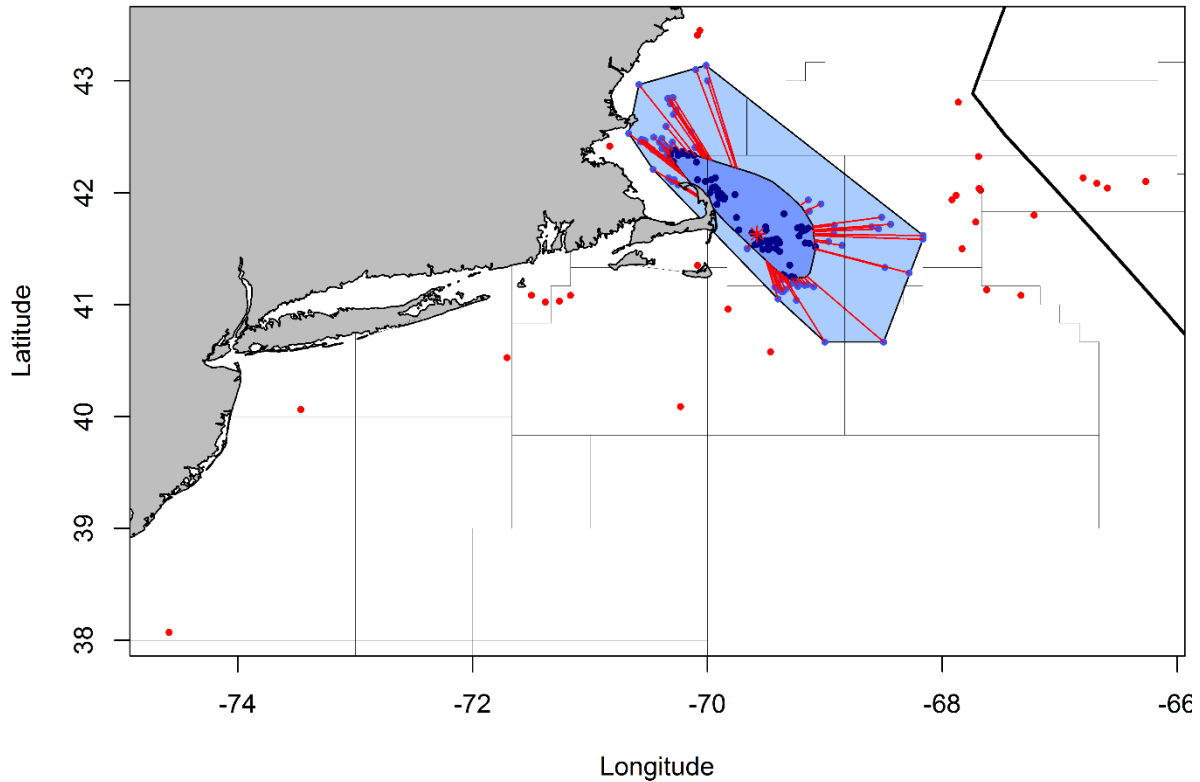


Figure 13. Recaptures of spawning cod tagged in the Cape Cod area during the post-spawning season, with median recapture position (red asterisk), area with 50% of recaptures (dark blue), approximately 95% of recaptures (light blue) and outliers (red dots).

Southern New England spawners demonstrated high spawning site fidelity (Table 8). During the release season (139 recaptures) there was 99% residence in the spawning area (537, 538, 539), with some movement to the Mid- Atlantic Bight (611, 613). During the post-spawning season (42 recaptures), there was 74% residence in southern New England, 19% movement to the Great South Channel (521), and 5% movement to the Mid-Atlantic Bight (612, 613). During subsequent spawning seasons (19 recaptures), there was 95% residence in southern New England and 5% movement to the Great South Channel (521). There were no recaptures of Southern New England spawners on eastern Georges Bank. Most spawning cod tagged in southern New England were recaptured in the area (Figure 14).

Table 8. Recaptures from the Massachusetts Marine Fisheries Institute of cod tagged during the spawning season (December-May) off southern New England (537, 539) and recaptured during the same spawning season, the post-spawning season (November-March) and subsequent spawning seasons. Colors indicate relative proportions and outlines indicate residence in area of release.

| Season of Recapture | Gulf of Maine | Great South Channel | Southern New England | Mid Atlantic Bight |
|---------------------|---------------|---------------------|----------------------|--------------------|
| Release             | 0.00          | 0.00                | 0.99                 | 0.01               |
| Post-spawning       | 0.02          | 0.19                | 0.74                 | 0.05               |
| Subsequent Spawning | 0.00          | 0.05                | 0.95                 | 0.00               |

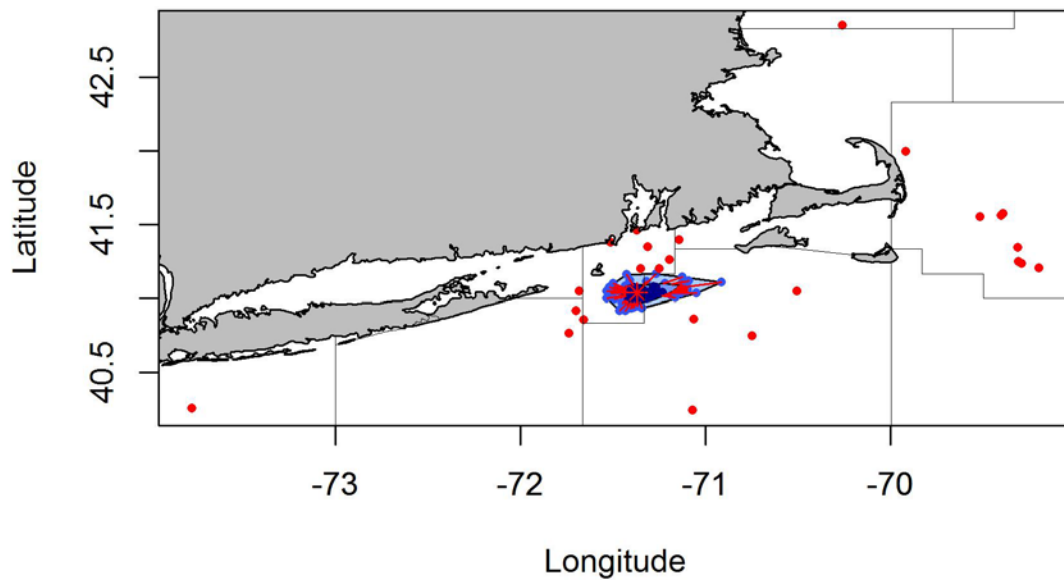


Figure 14. Recaptures of spawning cod tagged southern New England, with median recapture position (red asterisk), area with 50% of recaptures (dark blue), approximately 95% of recaptures (light blue) and outliers (red dots).

### *Habitat Occupancy and Movements from Archival Tagging*

DST's recovered from spring-spawning cod in Ipswich Bay (n=25) by Siceloff and Howell (2013) showed that most cod left the Ipswich Bay spawning ground during May and June and dispersed throughout the Gulf of Maine. Cod demonstrated little off-bottom movement while on the spawning ground, but most adopted various location-specific off-bottom movement behaviors after leaving the inshore spawning ground and moving to deeper waters post-spawning. A total of 49 DSTs were recovered from tagging in the SCCZ in Massachusetts Bay with the mean days at-liberty being 115 days (range = 9-635 days) (Zemeckis 2016; Zemeckis et al. 2017). The coldest temperatures were experienced from March through July, which roughly overlaps with the spring spawning season, with an increase over the summer and fall to the warmest months from September through January (Figure 23). Cod typically inhabited waters from 45-175 m depth (mean = 93 m, range = 3-268 m) (Figure 24). The deepest waters were



generally occupied in February and March, and the shallowest when likely present on the inshore spawning grounds in May and June.

The geolocation results for cod tagged in the SCCZ in Massachusetts Bay indicated that cod were primarily residential within the Gulf of Maine. There were 751 positions estimated for 36 fish during the spring-spawning season (16 April–15 July). Cod were mainly located in statistical areas 514 (92%) and 513 (6%) during this period. Cod also demonstrated a high degree of residency in the Gulf of Maine after the spawning season, but a greater proportion of positions came from other statistical areas. For example, from 16 July – 15 October (365 positions, 18 fish), 62% of positions were in 514, 17% in 513, 9% in 512, and 3% in 465. One fish was estimated to occupy occupied statistical area 521 for 35 d during this time period, which represents ~10% of days during this period and movement into the Georges Bank management unit. However, little movement south of Cape Cod or to Georges Bank was estimated for other individuals. During the 16 October–15 January period (70 positions, 4 fish), most positions were assigned to statistical areas 514 (17%), 512 (64%), and 465 (11%). Most positions during the 16 January–15 April period (24 positions, 4 fish) were assigned to statistical area 514 (46%) or 512 (42%).

A total of 88 DSTs from the MFI DST tagging studies were recovered with data suitable for analysis (Liu 2019). There were 19 DSTs recovered from cod tagged in the western Gulf of Maine on Stellwagen Bank or in Massachusetts Bay (mean days at liberty = 67 days, range = 21–105 days), most of which were tagged in March or April 2001 (n=10) and were included in Gröger et al. (2007) or they were released during March 2007 (n=7). These fish occupied the shallowest depths during April through June, which could be indicative of feeding on Stellwagen Bank. In contrast, deeper depths were occupied during December through February, which may indicate inshore spawning during the winter in Massachusetts Bay, but sample sizes are low for these months. The coldest water temperatures were occupied during February through March, while the warmest water temperatures were occupied during December and January (Figure 26). Geolocation results for these fish demonstrate that cod in this region are likely to be primarily residential in the western Gulf of Maine (Figure 15). Results from the HMM geolocation model suggested some movement from the western Gulf of Maine to the Great South Channel, but these movements were less frequent than estimated for a sub-set of these fish by Gröger et al. (2007). Therefore, geolocation results are sensitive to the chosen geolocation method, but the more statistically robust and rigorously validated HMM method is expected to produce more accurate results.

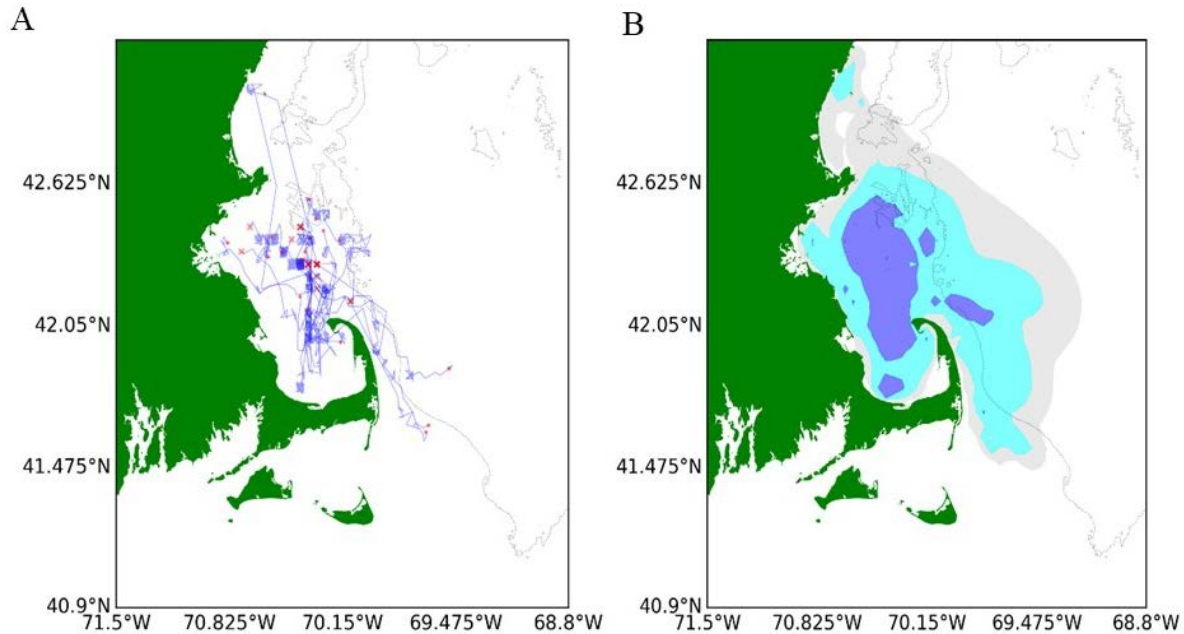


Figure 15. Geolocation results for recovered DSTs (n=19) from cod that were tagged in the western Gulf of Maine as a part of long-term tagging studies by the Massachusetts Marine Fisheries Institute (MFI), including (A) the most probable track for each individual (red 'X' = tagging locations, red dots = reported recovery locations) and (B) a plot of the utilization distribution (blue = 68%, teal = 95%, gray = 99%) to estimate the space use of this group of fish, from Liu (2019).

A total of five cod tagged with DSTs in the Great South Channel and Nantucket Shoals were recovered and had data suitable for analysis (mean days at liberty = 70 days, range = 15-124 days). Three of these fish were tagged in deep water (175 m) in the Great South Channel during March 2008, while the remaining fish were tagged in shallower waters (40 – 50 m) southeast of Chatham, MA in November 2006 and December 2009. The low sample size of recaptures from this region provides limited data to investigate the habitat occupancy of cod tagged in these regions. All five of these fish tagged in the Great South Channel were recaptured in the Gulf of Maine and both the most probable tracks and utilization distribution results provided additional evidence of connectivity among the Great South Channel and the Gulf of Maine (Figure 16).

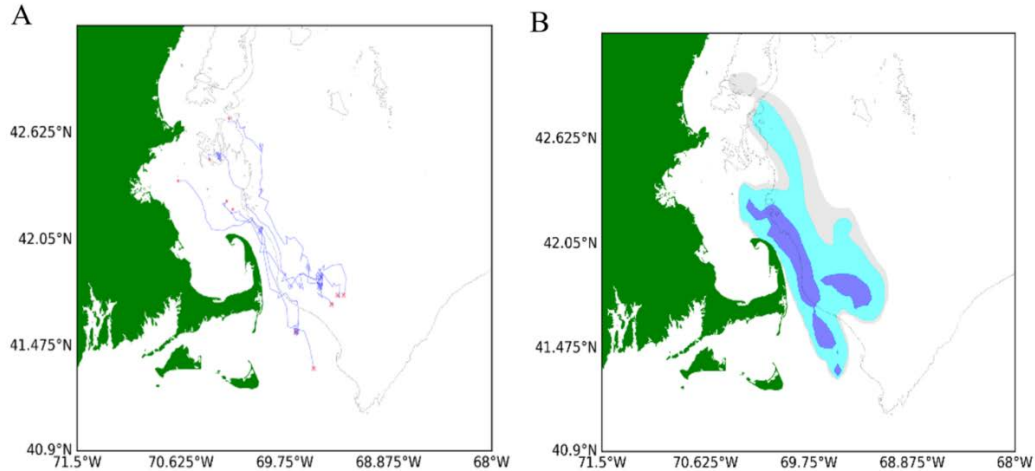


Figure 16. Geolocation results for recovered DSTs (n=5) from cod that were tagged in the Great South Channel and Nantucket Shoals as a part of long-term tagging studies by the Massachusetts Marine Fisheries Institute (MFI), including (A) the most probable track for each individual (red 'X' = tagging locations, red dots = reported recovery locations) and (B) a plot of the utilization distribution (blue = 68%, teal = 95%, gray = 99%) to estimate the space use of this group of fish, from Liu (2019).

A total of 64 DSTs were recovered from cod tagged with DSTs in southern New England waters (mean days at liberty = 73 days, range = 4-429 days). The seasonal habitat occupancy data demonstrate that cod tagged in southern New England typically utilize a relatively narrow depth range of approximately 40-90 m, which is shallower than most of the fish tagged in other regions. The coldest water temperatures occupied by cod in southern New England occurred during February through May with the warmest water temperatures occupied from September through November), which are generally warmer than the warmest temperatures experienced by cod tagged in other regions. Geolocation results suggest that cod tagged in southern New England were primarily residential in this area with some movement to the south towards the offshore canyons along the continental edge and southwest into the Mid-Atlantic (Figure 17). Two fish were estimated to have moved to the Great South Channel, one of which was estimated to have also moved into the Gulf of Maine.

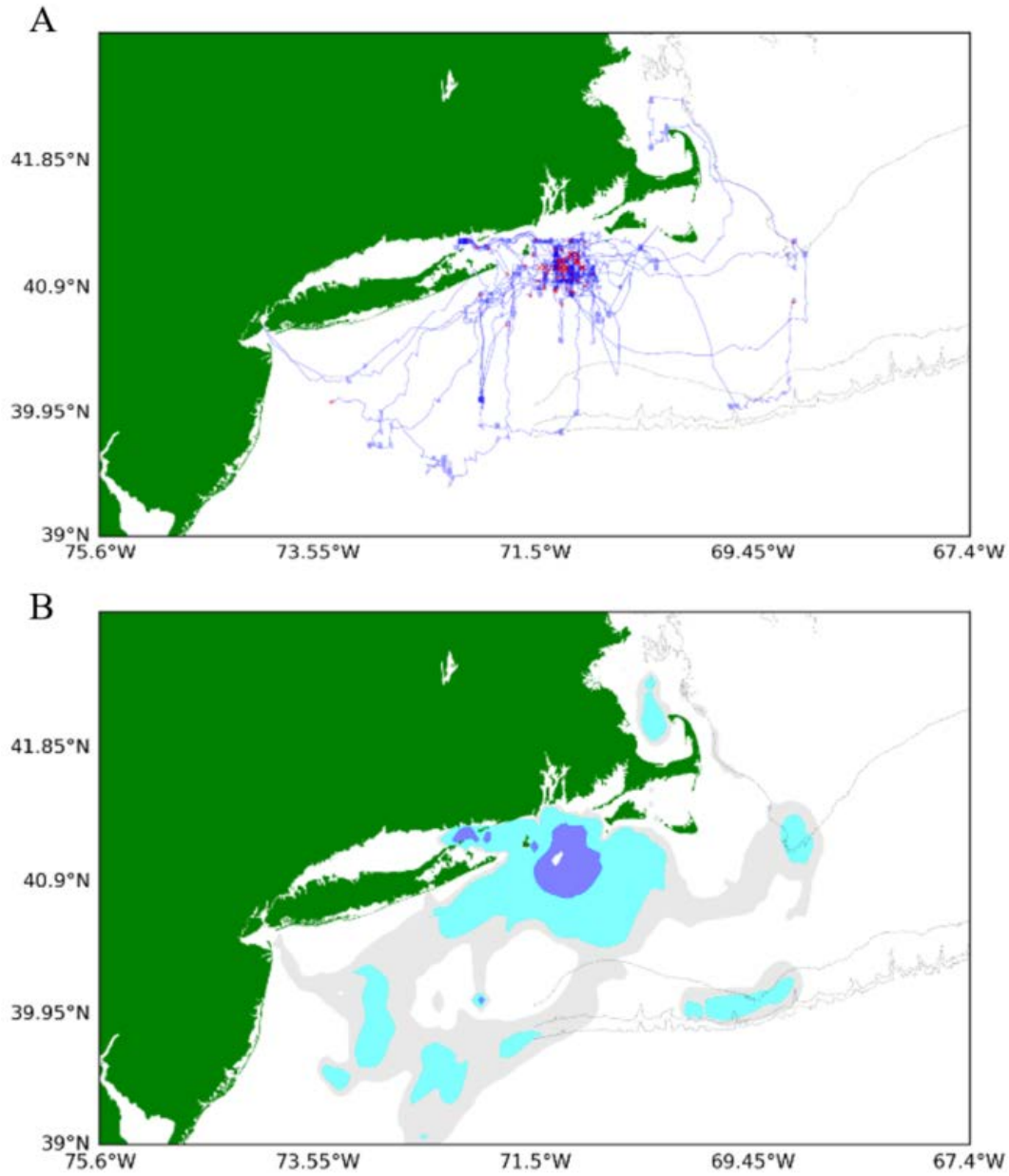


Figure 17. Geolocation results for recovered DSTs (n=64) from cod that were tagged in the Southern New England as a part of long-term tagging studies by the Massachusetts Marine Fisheries Institute (MFI), including (A) the most probable track for each individual (red 'X' = tagging locations, red dots = reported recovery locations) and (B) a plot of the utilization distribution (blue = 68%, teal = 95%, gray = 99%) to estimate the space use of this group of fish.

## Discussion

Some of the major patterns of residence, spawning site fidelity, and movement from tagging data appear to be persistent over decades. For example, the Northeast Regional Cod Tagging Program data (2002-2003 releases) show that cod in the Gulf of Maine are relatively sedentary with limited movement from the western Gulf of Maine to the Great South Channel (2%; Table 1a) and western Georges Bank (2%, 522, 525), similar to the historical tagging (Higgins 1929, 1933, 1934; Perkins et al. 1997). Recent tagging data also confirm that there is extensive movement from the Great South Channel to the western Gulf of Maine (e.g., 15% movement from 521 to 514, Table 1b), similar to the results reported by Wise (1963). Recent data also show greater movement from eastern Georges Bank to the western Scotian Shelf (16%, Table 1a) than to the Great South Channel (3%) similar to historical (Higgins 1931; Wise 1963) and contemporary (Hunt et al. 1999) tagging studies. The apparent boundary on western Georges Bank (approximately 68°W) identified by Wise (1963) is supported by recent tagging data, because there was 6% movement from the Great South Channel (521) to western Georges Bank (522, 525), but only 2% movement to eastern Georges Bank (551, 552, 561, 562). Although the Northeast Regional Cod Tagging Program did not have releases on the western Scotian Shelf (462, 463, 464, 465), the apparent boundary between the western Scotian Shelf and the eastern Scotian Shelf off southeast Nova Scotia persisted over several decadal tagging studies (McKenzie 1956; Hunt et al. 1999; Clark and Emberley 2010).

Other patterns of residence and dispersal have changed since the early 1900s. Some of the regional movement patterns indicated from analysis of the Schroeder tagging logs were considerably different than those observed in more recent tagging programs. The number of releases and recaptures off coastal Maine (512) also suggest much greater distribution of cod and fishing effort in that area in the early 1900s relative to recent decades. As described by Clark and Emberley (2010), dispersal from the Bay of Fundy appears to have increased. Historical tagging suggested more residence in the Bay of Fundy (Halliday 1971; McKenzie 1956; Hunt and Neilson 1993), than the Northeast Regional Cod Tagging Program data. Similar to the 2001-2002 tagging reported by Clark and Emberley (2010), the Northeast Regional Cod Tagging Program data suggest 17% dispersal of cod from the Bay of Fundy, including to the western Scotian Shelf (9%), Gulf of Maine (5%), and Georges Bank (3%).

The major patterns of residence and movement are consistent with information on stock identity from other disciplines. The apparent boundaries off southwest Nova Scotia (McKenzie 1956; Hunt et al. 1999; Clark and Emberley 2010) and on western Georges Bank (Wise and Jensen 1960; Wise 1963) are consistent with geographic variation in genetics between the eastern Scotian Shelf, eastern Georges Bank, and the Great South Channel (Chapter 3). The apparent spawning site fidelity of western Gulf of Maine winter spawners (Table 2), western Gulf of Maine spring spawners (Table 3), and spawners on eastern Georges Bank (Table 5) may maintain the genetic differences among those groups (Chapter 3). Conversely, the lower residence and greater dispersal of spawning cod from the Cape Cod grounds (e.g., 28% of cod tagged during the spawning season on Nantucket Shoals and in the Great South Channel were recaptured in the western Gulf of Maine in subsequent spawning seasons; Table 7) suggest greater reproductive connectivity with other groups and may explain their genetic similarity with the western Gulf of Maine and possibly southern New England (Chapter 3). The greater movement from the Great South Channel to the western Gulf of Maine (16%, Table 2) is also consistent with geographic variation in size at age, in which cod from the Great South Channel are more similar to those in the Gulf of Maine than those on Georges Bank (Chapter 4).

Inferences of residence and movement from conventional tags are constrained by spatiotemporal patterns in fishing effort and reporting rates. However, conclusions about broad-scale residence and movement appear to be robust to these effects, because results are similar to those from archival tags, which are much less constrained by fishery variables. In addition, the stability in tagging results over decades with different fishing patterns and fishery regulations, and the similarity of results from previous studies that attempted to account for fishing patterns further corroborate the general patterns described here (Hunt et al 1999; Howell et al. 2008; Loehrke 2014).

The tagging data available for exploring movement patterns of cod in the Gulf of Maine and adjacent areas (NAFO divisions 4X, 5, 6) is superlative, but some information gaps remain. The low abundance of cod in the eastern Gulf of Maine continues to be a challenge for tagging, and more tag releases (including small pop-up satellite tags), particularly of spawning cod from that area would be valuable. The recent studies of spawning dynamics for spring spawners in Ipswich Bay (Siceloff and Howell 2013), spring spawners in Massachusetts Bay (Dean et al. 2014; Zemeckis et al. 2014a; Zemeckis et al. 2017), and winter spawners in Massachusetts Bay (Zemeckis et al. 2019) show that advanced technologies can improve our understanding of spawning site fidelity and dispersal of other spawning groups that are currently active. For example, acoustic tagging of spawning cod on Cox Ledge would improve our understanding of their spawning dynamics. The recent delineation of spawning grounds on Georges Bank from Fishermen's Ecological Knowledge (Chapter 7) can be used to design conventional and electronic tagging studies to quantify movement patterns of those spawning groups.

## **Conclusion**

There is a wealth of mark-recapture observations focused on regional stocks of Atlantic cod that span more than 100 years, and include more than 200,000 tag releases and 10,000 recaptures. Regional patterns of residence and movement have been similar among tagging studies since the early 1900s. There is little movement of cod between the Gulf of Maine region and the eastern Scotian Shelf; cod in the western Gulf of Maine and the Bay of Fundy are relatively sedentary, yet there is some movement between the western Gulf of Maine and the Great South Channel. There is extensive movement between eastern Georges Bank and the western Scotian Shelf and between Nantucket Shoals and the Mid Atlantic Bight. Analysis of residence and dispersal of distinct spawning groups among fishing grounds suggest high residence and fidelity to spawning areas in the western Gulf of Maine and the Bay of Fundy, high spawning site fidelity on eastern Georges Bank with some post-spawning dispersal, and greater dispersal from the 'Cape Cod' spawning grounds. Major movement patterns are consistent among studies, but the frequency of residence and movement vary among studies.

## **Acknowledgments**

The literature review benefitted greatly from Jon Loehrke's previous review of US tagging and Don Clark's previous review of Canadian tagging. Fishermen played a central role in tag releases and reported recaptures. The Northeast Regional Cod Tagging Program was funded by the NEFSC Cooperative Research Partners Program and the New England Fisheries Management Council, was led by the Gulf of Maine Research Institute in partnership with the Canadian Department of Fisheries and Oceans, Island Institute, Maine Department of Marine Resources, Manomet Center for Conservation Sciences, Cape Cod Commercial Hook Fishermen's Association and the University of Massachusetts School for Marine Science and Technology.

The Massachusetts Marine Fisheries Institute was funded by the Massachusetts Fisheries Recovery Commission and NOAA. Mike Palmer provided data from Schroeder's logs, keypunched by Josh Moser, John 'JJ' Jones, Rosa Riley, Cathy Sumi, and Talia Bigelow. Chang Liu and Geoff Cowles led the geolocation of the Massachusetts Marine Fisheries Institute archival tags with funding from NOAA S-K.

## References Cited

- Clark DS, Emberley J. 2010. Assessment of Cod in Division 4X in 2008. Canadian Science Advisory Secretariat Research Document 2009/018.
- DeCelles G, Zemeckis, D. 2014. Acoustic and radio telemetry. In Cadrin SX Kerr L Mariani, editors. Stock Identification Methods. New York: Elsevier. p. 397-428.
- Dean MJ, Hoffman WS, Zemeckis DR, Armstrong MP 2014. Fine-scale diel and gender-based patterns in behaviour of Atlantic cod (*Gadus morhua*) on a spawning ground in the western Gulf of Maine. ICES Journal of Marine Science 71(6):1474-1489.
- Gröger JP, Rountree RA, Thygesen U H, Jones D, Martins D, Xu Q, Rothschild BJ. 2007. Geolocation of Atlantic cod (*Gadus morhua*) movements in the Gulf of Maine using tidal information. Fisheries Oceanography 16:317–335.
- Hall DA.. 2014. Conventional and radio frequency identification (RFID) tags. In Cadrin SX Kerr L Mariani, editors. Stock Identification Methods. New York: Elsevier. p. 365-397.
- Halliday RG, Pinhorn, AT. 1990. The delimitation of fishing areas in the Northwest Atlantic. J. Northw. Atl. Fish. Sci., Vol 10:1-51.
- Higgins E. 1929. Progress in biological inquiries, 1928, Including Extracts From the Proceedings of the Divisional Conference, January 2 to 5, 1929. Report of the U. S. commissioner of Fisheries for the fiscal year 1929. app. 10:627-739.
- Higgins E. 1931. Progress in biological inquiries, 1930. Report of the U. S. commissioner of Fisheries for the fiscal year 1931, app. 3:553-626.
- Higgins E. 1933. Progress in biological inquiries, 1932. Report of the U. S. commissioner of Fisheries for the fiscal year 1933, app. 2:79-147.
- Higgins E. 1934. Progress in biological inquiries, 1933. Report of the U. S. commissioner of Fisheries for the fiscal year 1934, app. 3:313-383.
- Hunt JJ, Neilson JD. 1993. Is there a separate stock of Atlantic cod in the western side of the Bay of Fundy? North American Journal of Fisheries Management 13:421–436.
- Hunt JJ, Stobo WT, Almeida F. 1999. Movement of Atlantic cod, *Gadus morhua*, tagged in the Gulf of Maine area. Fish. Bull. 97:842-861.

Howell WH, Morin M, Rennels N, Goethel D. 2008. Residency of adult Atlantic cod (*Gadus morhua*) in the western Gulf of Maine. *Fisheries Research* 91:123–132.

Kovach AI, Breton TS, Berlinsky DL, Maceda L, Wirgin I. 2010. Fine-scale spatial and temporal genetic structure of Atlantic cod off the Atlantic coast of the USA. *Marine Ecology Progress Series* 410:177-195.

Liu C. 2019. Geolocation Methods for Demersal Fish Species Using Archival Tagging Data. PhD Dissertation, University of Massachusetts, Dartmouth, MA, USA.

Liu C, Cowles G, Zemeckis DR, Cadrin SX, Dean MJ. 2017. Validation of a hidden Markov model for the geolocation of Atlantic cod. *Canadian Journal of Fisheries and Aquatic Sciences* 74(11): 1862-1877.

Loehrke JL. 2014. Movement patterns of Atlantic cod (*Gadus morhua*) spawning groups off New England. MS Thesis, University of Massachusetts, Dartmouth, MA, USA.

Loehrke J, Cadrin S. 2007. A Review of Tagging Information for Stock Identification of Cod off New England. Groundfish Assessment Review Meeting Working Paper C2. (<http://www.nefsc.noaa.gov/GARM-Public/1.DataMeeting/C.2%20GARMWP3B%20Cod%20Stocks.pdf>)

McKenzie RA. 1956. Atlantic cod tagging off the southern Canadian mainland. *Bull. Fish. Res. Bd. Can.* 105: 1-93.

NEFSC (Northeast Fisheries Science Center). 2017. Operational Assessment of 19 Northeast Groundfish Stocks, Updated Through 2016. NEFSC Ref. Doc. 17-17. p. 259.

O'Brien L, Burnett J, Mayo RK. 1993. Maturation of nineteen species of finfish off the northeast coast of the United States, 1985-1990. NOAA Technical Report NMFS 113. p. 72.

O'Brien L, Worcester T. 2009. Transboundary Resources Assessment Committee (TRAC) eastern Georges Bank cod benchmark assessment: report of meetings held 13-14 January 2009, 30 March-1 April 2009. TRAC Proceedings 2009/02.

Perkins HC, Chenoweth SB, Langton RW. 1997. The Gulf of Maine Atlantic cod complex, patterns of distribution and movement of the Sheepscot Bay substock. *Bulletin of National Research Institute of Aquaculture*, (Suppl. 3):101–107.

Rich WH. 1925. Progress in biological inquiries, July 1 to December 31, 1924. Report of the U. S. commissioner of Fisheries for the fiscal year 1925, app. 3: 37-64.

Rounsefell, GA. 1948. Development of fishery statistics in the North Atlantic. *Special Scientific Report No. 47*. p 17.



- Rousseeuw, PJ, Ruts, I, Tukey JW. 1999. The bagplot: A bivariate boxplot. *The American Statistician*, 53: 382-387.
- Schroeder WC. 1930. Migrations and other phases in the life history of the cod off southern New England. *Fish. Bull.* 46:1-136.
- Sokal RR, Rohlf FJ. 2012. *Biometry: the principles and practice of statistics in biological research*. W.H. Freeman and Co. New York.
- Siceloff, L. 2009. Fine-scale activity, distribution, and habitat utilization of Atlantic cod (*Gadus morhua*) on the Ipswich Bay spawning ground. M.S. Thesis Zoology, University of New Hampshire, Durham, NH.
- Siceloff L, Howell WH. 2013. Fine-scale temporal and spatial distributions of Atlantic cod (*Gadus morhua*) on a western Gulf of Maine spawning ground. *Fisheries Research* 141:31-43.
- Smith HM. 1902. Notes on the tagging of four thousand adult cod at Woods Hole, Massachusetts. *Rep. US Fish Comm.*, 27: 193-208.
- Tallack S, Ed. 2009. Proceedings from a workshop to identify future research priorities for cod tagging in the Gulf of Maine, 12 February, 2009. NEFSC Ref Doc. 09-09. p. 76.
- Tallack SML. 2011. Stock identification applications of conventional tagging data for Atlantic cod in the Gulf of Maine. In *Proceedings from the 2nd International Symposium on Advances in Fish Tagging and Marking Techniques*, pp. 1–15. Ed. by J. McKenzie, B. Parsons, A. C. Seitz, R. K. Kopf, M. Mesa, and Q. Phelps. American Fisheries Society Symposium, 76. 560 pp.
- Templeman W. 1962. Divisions of cod stocks in the northwest Atlantic. ICNAF Redbook, 1962 Part III: 79-123.
- Wang Y, O'Brien L, Gavaris S, Hatt B. 2009. Assessment of eastern Georges Bank Atlantic cod for 2009. TRAC Reference Document 2009/07.
- Wise JP. 1958. The world's southernmost indigenous cod. *J. Cons. Int. Explor. Mer.* 23:208-212.
- Wise JP. 1963. Cod groups in the New England area. *U.S. Fish Wild. Serv. Fish. Bull.* 63: 189-203.
- Wise JP, Jensen AC. 1960. Stocks of the important commercial species of fish in the ICNAF Convention area. *Int. Comm. NW Atl. Fish. Ann. Meet. Doc.* 25, ser. No 743:1-14.
- Zemeckis DR, Hoffman WS, Dean MJ, Armstrong MP, Cadrin SX. 2014a. Spawning site fidelity by Atlantic cod (*Gadus morhua*) in the Gulf of Maine: implications for population structure and rebuilding. *ICES Journal of Marine Science* 71(6):1356-1365.

Zemeckis DR, Martins D, Kerr LA, Cadrin SX. 2014b. Stock identification of Atlantic cod (*Gadus morhua*) in US waters: an interdisciplinary approach. ICES Journal of Marine Science 71(6): 1490-1506.

Zemeckis DR. 2016. Spawning dynamics, seasonal movements, and population structure of Atlantic cod (*Gadus morhua*) in the Gulf of Maine. Ph.D. Dissertation, University of Massachusetts Dartmouth, Dartmouth, MA.

Zemeckis, DR, Liu C, Cowles GW, Dean MJ, Hoffman WS, Martins D, Cadrin SX. 2017. Seasonal movements and connectivity of an Atlantic cod (*Gadus morhua*) spawning component in the western Gulf of Maine. ICES Journal of Marine Science 74(6):1780-1796.

Zemeckis DR, Dean MJ, DeAngelis AI, Van Parijs SM, Hoffman WS, Baumgartner MF, Hatch LT, Cadrin SX, McGuire CH. 2019. Identifying the distribution of Atlantic cod spawning using multiple fixed and glider-mounted acoustic technologies. ICES Journal of Marine Science (in press).

# APPENDICES

## Appendix A. Schroeder Logs

There were 2,097 reported recaptures from the keypunched Schroeder logs with recapture positions. Cod were tagged from eastern Gulf of Maine to the Mid Atlantic Bight from 1923-1927, with some reported recaptures up to six years at-liberty. There was high regional residence as well as some substantial regional movements (Table A1a). Regional residence was 97% in the Gulf of Maine, 36% in the Great South Channel, and 28% in southern New England. Substantial regional movements (>10%) were from the Great South Channel to the Gulf of Maine (20%), from Georges Bank to the Gulf of Maine (20%) and to the Mid Atlantic Bight (20%), and from southern New England to the Mid Atlantic Bight (40%), to the Gulf of Maine (17%), and to the Great South Channel (13%). There was >50% residence in statistical areas (Table A1b) off eastern ME (511), mid-coast ME (512), southern ME-NH (513), and southwest Gulf of Maine (514), but not in the Great South Channel (521).

There were many more releases and recaptures from mid-coast ME (512) than reported in more recent tagging studies, indicating much more fishing in that area in the early 1900s. Some regional movement patterns were considerably different than those observed in more recent tagging programs (e.g., less movement from Georges Bank to the western Scotian Shelf, and more movement from Georges Bank to the Gulf of Maine and to the Mid Atlantic Bight, and from the Great South Channel and southern New England to the Mid Atlantic Bight). The number of releases and recaptures off coastal Maine (512) also suggest much greater distribution of cod and fishing effort in that area than in recent decades. Therefore, these results were not pooled with those from more recent tagging. With the possible exception of the ‘Cape Cod’ spawning group (640 recaptures from releases in area 521), there were insufficient number of recaptures from currently active spawning groups to support a seasonal breakdown of recaptures.

Table A1a. All tag recaptures from the Schroeder logs by statistical area of release (Rel.) and recapture. Colors indicate geographic regions (green: Gulf of Maine; dark green: western Gulf of Maine; white: Great South Channel; orange: Georges Bank; red: southern New England-Mid-Atlantic) and outlines indicate regional residence.

| Rel. | Recapture Area |     |     |     |     |     |      |     |     |     |     |     |     |     |     |     |     |     |     |     | Sum |     |     |     |     |     |     |   |      |   |      |
|------|----------------|-----|-----|-----|-----|-----|------|-----|-----|-----|-----|-----|-----|-----|-----|-----|-----|-----|-----|-----|-----|-----|-----|-----|-----|-----|-----|---|------|---|------|
|      | 461            | 463 | 465 | 466 | 467 | 511 | 512  | 513 | 514 | 515 | 521 | 522 | 525 | 551 | 552 | 562 | 526 | 537 | 538 | 539 |     | 611 | 612 | 613 | 614 | 615 | 621 | ? |      |   |      |
| 511  |                |     |     |     |     | 26  | 22   |     |     |     |     |     |     |     |     |     |     |     |     |     |     |     |     |     |     |     |     | 2 | 50   |   |      |
| 512  | 4              | 3   | 4   | 5   | 3   | 29  | 1104 | 6   | 12  |     | 1   |     |     |     |     | 1   |     |     |     |     |     |     |     |     |     |     |     |   |      | 4 | 1176 |
| 513  | 1              |     |     |     |     | 4   | 141  | 1   | 3   | 6   | 4   |     |     |     |     |     | 1   |     | 1   |     |     |     |     |     |     |     |     |   |      | 1 | 163  |
| 514  |                |     |     | 1   |     | 2   |      | 4   |     |     |     |     |     |     |     |     |     |     |     |     |     | 1   | 1   |     | 1   |     |     |   |      |   | 10   |
| 521  | 1              |     |     |     | 1   | 1   | 85   | 7   | 34  | 225 |     | 1   |     |     |     | 5   | 48  | 8   | 5   | 24  | 18  | 83  | 17  | 37  | 4   | 16  | 20  |   | 640  |   |      |
| 551  |                |     |     |     |     |     |      |     | 1   |     |     |     | 1   | 1   |     |     |     |     |     |     |     | 1   |     |     |     |     |     |   |      |   | 4    |
| 561  |                |     |     |     |     |     |      |     |     |     |     |     |     | 1   |     |     |     |     |     |     |     |     |     |     |     |     |     |   |      |   | 1    |
| 526  | 1              |     |     |     |     |     | 6    |     |     | 4   |     |     |     |     |     |     |     |     |     |     |     |     | 1   |     | 1   |     |     |   |      |   | 13   |
| 537  |                |     |     |     |     |     |      | 2   |     | 1   |     |     |     |     |     |     |     | 2   |     | 1   |     |     |     |     |     |     |     |   |      |   | 6    |
| 538  |                |     |     |     |     |     |      |     |     | 1   |     |     |     |     |     |     | 1   | 1   |     | 8   |     | 4   | 5   | 8   |     |     |     |   |      | 6 | 34   |
| Sum  | 7              | 3   | 4   | 6   | 4   | 56  | 1223 | 156 | 52  | 3   | 238 | 4   | 1   | 1   | 2   | 6   | 50  | 11  | 6   | 33  | 24  | 90  | 25  | 39  | 4   | 16  | 33  |   | 2097 |   |      |

Table A1b. All tag recaptures from the Schroeder logs by statistical area of release (Rel.) and recapture, expressed as the proportion of known-area recaptures from each release area. Outlines indicate residence in each area.

| Rel. | Recapture Area |      |      |      |      |      |      |      |      |      |      |      |      |     |      |      |      |      |      |      |      |      |      |      |      |      |
|------|----------------|------|------|------|------|------|------|------|------|------|------|------|------|-----|------|------|------|------|------|------|------|------|------|------|------|------|
|      | 461            | 463  | 465  | 466  | 467  | 511  | 512  | 513  | 514  | 515  | 521  | 522  | 525  | 551 | 552  | 562  | 526  | 537  | 538  | 539  | 611  | 612  | 613  | 614  | 615  | 621  |
| 511  | 0              | 0    | 0    | 0    | 0    | 0.54 | 0.46 | 0    | 0    | 0    | 0    | 0    | 0    | 0   | 0    | 0    | 0    | 0    | 0    | 0    | 0    | 0    | 0    | 0    | 0    | 0    |
| 512  | 0.00           | 0.00 | 0.00 | 0.00 | 0.00 | 0.02 | 0.94 | 0.01 | 0.01 | 0    | 0.00 | 0    | 0    | 0   | 0    | 0.00 | 0    | 0    | 0    | 0    | 0    | 0    | 0    | 0    | 0    | 0    |
| 513  | 0.01           | 0    | 0    | 0    | 0    | 0    | 0.02 | 0.87 | 0.01 | 0.02 | 0.04 | 0.02 | 0    | 0   | 0    | 0    | 0.01 | 0    | 0.01 | 0    | 0    | 0    | 0    | 0    | 0    | 0    |
| 514  | 0              | 0    | 0    | 0.10 | 0    | 0    | 0.20 | 0    | 0.40 | 0    | 0    | 0    | 0    | 0   | 0    | 0    | 0    | 0    | 0    | 0    | 0    | 0.10 | 0.10 | 0    | 0.10 | 0    |
| 521  | 0.00           | 0    | 0    | 0    | 0.00 | 0.00 | 0.14 | 0.01 | 0.05 | 0    | 0.36 | 0    | 0.00 | 0   | 0    | 0.01 | 0.08 | 0.01 | 0.01 | 0.04 | 0.03 | 0.13 | 0.03 | 0.06 | 0.01 | 0.03 |
| 551  | 0              | 0    | 0    | 0    | 0    | 0    | 0    | 0    | 0.25 | 0    | 0    | 0    | 0    | 0   | 0.25 | 0.25 | 0    | 0    | 0    | 0    | 0.25 | 0    | 0    | 0    | 0    | 0    |
| 561  | 0              | 0    | 0    | 0    | 0    | 0    | 0    | 0    | 0    | 0    | 0    | 0    | 0    | 0   | 1.00 | 0    | 0    | 0    | 0    | 0    | 0    | 0    | 0    | 0    | 0    | 0    |
| 526  | 0.08           | 0    | 0    | 0    | 0    | 0    | 0.46 | 0    | 0    | 0    | 0.31 | 0    | 0    | 0   | 0    | 0    | 0    | 0    | 0    | 0    | 0    | 0.08 | 0    | 0.08 | 0    | 0    |
| 537  | 0              | 0    | 0    | 0    | 0    | 0    | 0    | 0.33 | 0    | 0    | 0.17 | 0    | 0    | 0   | 0    | 0    | 0    | 0    | 0.33 | 0    | 0.17 | 0    | 0    | 0    | 0    | 0    |
| 538  | 0              | 0    | 0    | 0    | 0    | 0    | 0    | 0    | 0    | 0    | 0.04 | 0    | 0    | 0   | 0    | 0    | 0.04 | 0.04 | 0    | 0.29 | 0.14 | 0.18 | 0.29 | 0    | 0    | 0    |

There are too few recoveries from the western Gulf of Maine releases (n=173), Georges Bank releases (n=5), and southern New England releases (n=53) from the Schroeder logs to support seasonal recovery matrices.

The Schroeder logs include many tag releases from mid-coast Maine (512) and many recaptures from those releases. Bigelow and Schroeder (1953) report that "off the western coast of Maine, according to Capt. E. E. Hahn, former superintendent of the Boothbay Harbor hatchery, cod spawn from late February or early March until the last of May, with the production of eggs at its peak in March; they spawn from March through May off the eastern Maine coast, and cod eggs (and hence spawning cod) have been recorded in spring in the Bay of Fundy." There were no releases from 512 in February or March, but recaptures from releases in April-May (Table A2) suggest high spawning site fidelity in subsequent spawning seasons (93%).

Table A2. Recaptures from the Schroeder logs of cod tagged during the spawning season (February-May) off mid-coast Maine (512) and recaptured during the same spawning season, the post-spawning season (February-September), and subsequent spawning seasons. Colors indicate relative proportions and outlines indicate residence in area of release.

| Season of Release                  |  | Recapture Area (# recaptures) |     |     |     |     |     |     |     |     |     |     |      |      |      |      |      |      |      |      |      |      |     |   |  |  |  |  |
|------------------------------------|--|-------------------------------|-----|-----|-----|-----|-----|-----|-----|-----|-----|-----|------|------|------|------|------|------|------|------|------|------|-----|---|--|--|--|--|
|                                    |  | 461                           | 463 | 465 | 466 | 467 | 511 | 512 | 513 | 514 | 562 | ?   | Sum  | 461  | 463  | 465  | 466  | 467  | 511  | 512  | 513  | 514  | 562 |   |  |  |  |  |
| 512                                |  |                               |     |     |     |     | 1   | 15  |     |     |     |     | 16   | 0    | 0    | 0    | 0    | 0    | 0    | 0.06 | 0.94 | 0    | 0   | 0 |  |  |  |  |
| <b>Post-Spawning Season</b>        |  |                               |     |     |     |     |     |     |     |     |     |     |      |      |      |      |      |      |      |      |      |      |     |   |  |  |  |  |
| 512                                |  | 1                             | 1   | 2   | 1   | 1   | 4   | 349 | 2   | 8   | 2   | 371 | 0.00 | 0.00 | 0.01 | 0.00 | 0.00 | 0.01 | 0.95 | 0.01 | 0.02 | 0    |     |   |  |  |  |  |
| <b>Subsequent Spawning Seasons</b> |  |                               |     |     |     |     |     |     |     |     |     |     |      |      |      |      |      |      |      |      |      |      |     |   |  |  |  |  |
| 512                                |  |                               |     | 1   | 1   |     |     | 50  |     | 1   | 1   | 54  | 0    | 0    | 0.02 | 0.02 | 0    | 0    | 0.93 | 0    | 0.02 | 0.02 |     |   |  |  |  |  |

Historical spawning in the ‘Cape Cod’ area was described by Bigelow & Schroeder (1953): *"The broken bottom of Nantucket Shoals, east and south of Nantucket Island, has long been known as a center of abundance for ripe cod fish in late autumn and early winter... On Nantucket Shoals, ripening fish are caught from late October on, with the cod spawning there in early November to mid-February, and occasionally until April."* There were no tag releases in Schroeder’s logs in February, so the same spawning season (October-January) was assumed as for the more recent studies. Results suggest relatively low (32%) spawning site fidelity in subsequent spawning seasons, and substantial movement (45%) to southern New England Mid-Atlantic regions (Table A3).

Table A3. Recaptures from the Schroeder logs of cod tagged during the spawning season (October-January) in the ‘Cape Cod’ area (521) and recaptured during the same spawning season, the post-spawning season (February-September), and subsequent spawning seasons. Colors indicate relative proportions and outlines indicate residence in area of release.

| Season of Release                  |     | Recapture Area (# recaptures) |     |     |     |     |     |     |     |     |     |     |     |   |     | (proportion by area) |      |      |      |      |      |      |      |      |      |      |     |      |  |
|------------------------------------|-----|-------------------------------|-----|-----|-----|-----|-----|-----|-----|-----|-----|-----|-----|---|-----|----------------------|------|------|------|------|------|------|------|------|------|------|-----|------|--|
| Rel.                               | 512 | 514                           | 521 | 562 | 526 | 537 | 539 | 611 | 612 | 613 | 614 | 615 | 621 | ? | Sum | 512                  | 514  | 521  | 562  | 526  | 537  | 539  | 611  | 612  | 613  | 614  | 615 | 621  |  |
| 521                                |     | 1                             | 5   |     | 1   |     | 2   |     | 25  | 4   | 6   |     | 1   | 3 | 48  | 0                    | 0.02 | 0.11 | 0    | 0.02 | 0    | 0.04 | 0    | 0.56 | 0.09 | 0.13 | 0   | 0.02 |  |
| <b>Post-Spawning Season</b>        |     |                               |     |     |     |     |     |     |     |     |     |     |     |   |     |                      |      |      |      |      |      |      |      |      |      |      |     |      |  |
| 521                                |     | 8                             | 34  | 2   | 6   | 2   | 2   | 2   | 5   | 3   | 8   | 2   |     | 3 | 77  | 0                    | 0.11 | 0.46 | 0.03 | 0.08 | 0.03 | 0.03 | 0.03 | 0.07 | 0.04 | 0.11 | 0   | 0.00 |  |
| <b>Subsequent Spawning Seasons</b> |     |                               |     |     |     |     |     |     |     |     |     |     |     |   |     |                      |      |      |      |      |      |      |      |      |      |      |     |      |  |
| 521                                | 1   |                               | 7   |     | 2   |     | 1   | 2   | 4   | 1   | 1   |     | 1   | 2 | 22  | 0.1                  | 0    | 0.35 | 0    | 0.10 | 0    | 0.05 | 0.10 | 0.20 | 0.05 | 0.05 | 0   | 0.05 |  |



Seasonal patterns of recaptures demonstrated high spawning site fidelity and dispersal in the post-spawning season (Table B2). There were few recaptures (n=6) with reported recapture locations during the release season. During the post-spawning season (179 recaptures with locations), there was 66% residence on Georges Bank (522, 551, 552, 561, 562) and 32% movement to Scotian Shelf and Bay of Fundy. During subsequent spawning seasons (119 recaptures with locations), there was 53% residence on Georges Bank and 45% movement to Scotian Shelf and Bay of Fundy.

Table B2. Recaptures from the Schroeder logs of cod tagged during the spawning season (December-May) on Georges Bank (522, 551, 552, 561, 562) and recaptured during the same spawning season, the post-spawning season (June-November), and subsequent spawning seasons. Colors indicate relative proportions and outlines indicate residence in each area.

|                                    |      | Recapture Area (# recaptures) |      |      |      |      |      |      |      |      |      |      |      |      |      |    |     |
|------------------------------------|------|-------------------------------|------|------|------|------|------|------|------|------|------|------|------|------|------|----|-----|
| <b>Season of Release</b>           |      |                               |      |      |      |      |      |      |      |      |      |      |      |      |      |    |     |
| Rel.                               | 461  | 462                           | 463  | 464  | 465  | 466  | 511  | 514  | 515  | 521  | 522  | 551  | 552  | 561  | 562  | ?  | Sum |
| 552                                |      |                               |      | 2    |      |      |      | 1    |      | 1    |      | 1    |      | 1    |      | 4  | 10  |
| <b>Post-Spawning Season</b>        |      |                               |      |      |      |      |      |      |      |      |      |      |      |      |      |    |     |
| 551                                |      |                               |      |      | 1    |      |      |      |      |      |      | 3    |      |      |      | 1  | 5   |
| 552                                | 3    | 8                             | 19   | 8    | 13   | 4    | 2    |      | 1    |      | 2    | 74   | 23   | 1    |      | 31 | 189 |
| 562                                |      |                               |      | 1    |      |      |      |      |      | 1    |      | 8    | 5    |      | 2    | 4  | 21  |
| Sum                                | 3    | 8                             | 19   | 9    | 14   | 4    | 2    |      | 1    | 1    | 2    | 85   | 28   | 1    | 2    | 36 | 215 |
| <b>Subsequent Spawning Seasons</b> |      |                               |      |      |      |      |      |      |      |      |      |      |      |      |      |    |     |
| 551                                |      |                               |      |      | 1    |      |      |      |      |      |      | 2    |      |      |      | 1  | 4   |
| 552                                | 3    | 8                             | 17   | 7    | 12   | 4    | 2    |      |      |      |      | 42   | 8    | 1    |      | 25 | 129 |
| 562                                |      |                               |      | 1    |      |      |      |      |      | 1    |      | 7    | 1    |      | 2    | 4  | 16  |
| Sum                                | 3    | 8                             | 17   | 8    | 13   | 4    | 2    |      |      | 1    |      | 51   | 9    | 1    | 2    | 30 | 149 |
|                                    |      | (proportion by area)          |      |      |      |      |      |      |      |      |      |      |      |      |      |    |     |
| <b>Season of Release</b>           |      |                               |      |      |      |      |      |      |      |      |      |      |      |      |      |    |     |
| Rel.                               | 461  | 462                           | 463  | 464  | 465  | 466  | 511  | 514  | 515  | 521  | 522  | 551  | 552  | 561  | 562  |    |     |
| 552                                | 0    | 0                             | 0    | 0.33 | 0    | 0    | 0    | 0.17 | 0    | 0.17 | 0    | 0.17 | 0    | 0.17 | 0    |    |     |
| <b>Post-Spawning Season</b>        |      |                               |      |      |      |      |      |      |      |      |      |      |      |      |      |    |     |
| 551                                | 0    | 0                             | 0    | 0    | 0.25 | 0    | 0    | 0    | 0    | 0    | 0    | 0.75 | 0    | 0    | 0    |    |     |
| 552                                | 0.02 | 0.05                          | 0.12 | 0.05 | 0.08 | 0.03 | 0.01 | 0    | 0.01 | 0    | 0.01 | 0.47 | 0.15 | 0.01 | 0    |    |     |
| 562                                | 0    | 0                             | 0    | 0.06 | 0    | 0    | 0    | 0    | 0    | 0.06 | 0    | 0.47 | 0.29 | 0    | 0.12 |    |     |
| <b>Subsequent Spawning Seasons</b> |      |                               |      |      |      |      |      |      |      |      |      |      |      |      |      |    |     |
| 551                                | 0    | 0                             | 0    | 0    | 0.33 | 0    | 0    | 0    | 0    | 0    | 0    | 0.67 | 0    | 0    | 0    |    |     |
| 552                                | 0.03 | 0.08                          | 0.16 | 0.07 | 0.12 | 0.04 | 0.02 | 0    | 0    | 0    | 0    | 0.40 | 0.08 | 0.01 | 0    |    |     |
| 562                                | 0    | 0                             | 0    | 0.08 | 0    | 0    | 0    | 0    | 0    | 0.08 | 0    | 0.58 | 0.08 | 0    | 0.17 |    |     |

### Appendix C. Northeast Regional Cod Tagging Program

From the 2002-2004 Northeast Regional Cod Tagging Program, there were 6,784 reported recaptures, and 6,166 were reported with recapture positions, some at large for up to 4.5 years. Regional residence was generally high, but there was also some substantial movements between regions (Table C1a). Regional residence was 92% in Scotian Shelf and Bay of Fundy, 92% in the Gulf of Maine (95% in the western Gulf of Maine, but only 43% residence in eastern Gulf of Maine), 71% in the Great South Channel, 79% on Georges Bank, and 71% in southern New England. Substantial regional movements (>10%) were from the Great South Channel to the western Gulf of Maine (16%), from Georges Bank to Scotian Shelf and Bay of Fundy (16%), and from southern New England to the Great South Channel (20%).

Table C1a. All tag recaptures from the Northeast Regional Cod Tagging Program by statistical area of release (Rel.) and recapture. Colors indicate geographic regions (blue: Bay of Fundy; green: Gulf of Maine; dark green: western Gulf of Maine; white: Great South Channel; orange: Georges Bank; red: S. New England-Mid-Atlantic) and outlines indicate regional residence.

| Rel. | Recapture Area |     |     |     |     |     |     |     |      |     |     |      |     |     |     |     |     |     |     |     |     |     |     |     |     |     | Sum |     |      |      |    |
|------|----------------|-----|-----|-----|-----|-----|-----|-----|------|-----|-----|------|-----|-----|-----|-----|-----|-----|-----|-----|-----|-----|-----|-----|-----|-----|-----|-----|------|------|----|
|      | 462            | 463 | 464 | 465 | 466 | 467 | 511 | 512 | 513  | 514 | 515 | 521  | 522 | 525 | 551 | 561 | 562 | 526 | 537 | 538 | 539 | 611 | 612 | 613 | 615 | 616 |     | 621 | ?    |      |    |
| 466  | 1              |     | 9   | 19  | 172 | 224 | 6   |     | 3    |     |     |      | 4   |     | 9   | 1   |     |     |     |     |     |     |     |     |     |     |     | 1   | 17   | 466  |    |
| 467  |                | 1   | 22  | 28  | 133 | 203 | 16  | 3   | 8    | 3   |     |      | 1   | 4   | 1   | 11  |     |     |     |     |     |     |     |     |     |     |     |     | 18   | 452  |    |
| 511  |                |     | 17  | 30  | 10  | 7   | 40  |     | 2    | 2   |     |      | 1   |     | 8   | 4   |     |     |     |     |     |     |     |     |     |     |     |     | 11   | 132  |    |
| 512  |                |     |     | 1   |     |     |     | 1   | 10   | 4   | 1   |      | 1   |     |     |     |     |     |     |     |     |     |     |     |     |     |     |     |      | 18   |    |
| 513  |                |     | 3   | 1   | 2   | 1   |     |     | 1291 | 287 | 19  | 31   | 14  |     | 3   |     | 1   | 1   |     |     |     |     |     |     |     |     |     |     | 150  | 1804 |    |
| 514  |                |     |     |     |     |     |     |     | 22   | 70  | 1   |      | 4   |     |     |     |     |     |     |     |     |     |     |     |     |     |     |     | 11   | 108  |    |
| 515  |                |     | 5   | 1   |     | 1   |     | 1   | 16   | 11  | 76  | 6    | 14  | 1   | 1   | 1   |     |     |     |     |     |     |     |     |     |     |     |     | 8    | 142  |    |
| 521  |                |     | 3   | 1   | 2   | 1   |     |     | 33   | 314 | 3   | 1526 | 95  | 39  | 20  | 12  | 6   | 39  | 20  | 3   | 24  | 2   | 5   | 7   | 2   | 1   | 2   | 314 | 2474 |      |    |
| 522  | 1              |     | 35  | 4   | 2   | 7   | 3   |     | 1    | 2   |     | 10   | 71  | 5   | 106 | 16  | 11  |     | 2   |     |     |     |     |     |     |     |     |     | 25   | 301  |    |
| 525  |                |     | 2   |     |     |     |     |     | 1    |     |     | 2    | 2   | 3   | 17  | 2   | 1   |     |     |     |     |     |     |     |     |     |     |     | 2    | 32   |    |
| 551  |                |     |     | 2   |     | 1   |     |     |      |     |     | 1    |     |     | 1   |     |     |     |     |     |     |     |     |     |     |     |     |     |      | 5    |    |
| 552  |                |     |     | 1   |     |     |     |     |      |     |     |      |     |     |     |     |     |     |     |     |     |     |     |     |     |     |     |     |      | 1    | 2  |
| 561  | 1              | 8   | 52  | 9   | 4   | 10  | 2   | 1   | 5    |     |     | 22   | 74  | 13  | 167 | 154 | 31  |     |     |     |     |     |     |     |     |     |     |     | 42   | 595  |    |
| 562  | 1              |     | 16  | 3   | 1   | 6   |     |     |      |     |     |      | 16  | 6   | 53  | 24  | 41  |     |     |     |     |     |     |     |     |     |     |     | 19   | 186  |    |
| 526  |                |     |     |     |     |     |     |     | 1    | 1   |     | 9    |     | 1   |     |     |     | 1   |     |     | 1   |     |     |     |     |     |     |     |      | 14   |    |
| 537  |                |     |     |     |     |     |     |     |      |     |     | 2    |     |     | 1   |     |     |     |     | 9   |     | 7   |     |     |     |     |     |     |      | 19   |    |
| 539  |                |     |     |     |     |     |     |     |      |     |     |      |     |     |     |     |     |     | 8   |     | 14  |     | 1   |     |     |     |     |     |      | 23   |    |
| ?    |                |     |     |     | 2   | 8   |     |     | 1    |     |     |      |     |     |     |     |     |     |     |     |     |     |     |     |     |     |     |     |      |      | 11 |
| Sum  | 4              | 9   | 164 | 100 | 328 | 469 | 67  | 6   | 1394 | 694 | 100 | 1614 | 296 | 69  | 397 | 214 | 91  | 43  | 37  | 3   | 46  | 3   | 5   | 7   | 2   | 1   | 3   | 618 | 6784 |      |    |



Residence and movement from statistical areas indicates >50% residence in the northwest Bay of Fundy (467), southern ME-NH (513), southwest Gulf of Maine (514), central Gulf of Maine (515), Great South Channel (521), offshore S. New England (537), and RI Sound (539). Substantial movement (>50%) was from the northeast Bay of Fundy (466) to the northwest Bay of Fundy (467), from mid-coast ME (512) to southern ME-NH (513), from southwest Georges Bank (525) to northeast Georges Bank (551), and from Nantucket Shoals (526) to Great South Channel (521).

Table C1b. All tag recaptures from the Northeast Regional Cod Tagging Program by statistical area of release (Rel.) and recapture, expressed as the proportion of known-area recaptures from each release area. Outlines indicate residence in each area.

| Rel. | Recapture Area |     |     |     |     |     |     |     |      |     |      |      |     |     |     |     |     |     |     |     |     |     |     |     |     |     |     |
|------|----------------|-----|-----|-----|-----|-----|-----|-----|------|-----|------|------|-----|-----|-----|-----|-----|-----|-----|-----|-----|-----|-----|-----|-----|-----|-----|
|      | 462            | 463 | 464 | 465 | 466 | 467 | 511 | 512 | 513  | 514 | 515  | 521  | 522 | 525 | 551 | 561 | 562 | 526 | 537 | 538 | 539 | 611 | 612 | 613 | 615 | 616 | 621 |
| 466  | 0              | 0   | 0   | 0   | 0.4 | 0.5 | 0   | 0   | 0.01 | 0   | 0    | 0    | 0   | 0   | 0   | 0   | 0   | 0   | 0   | 0   | 0   | 0   | 0   | 0   | 0   | 0   | 0   |
| 467  | 0              | 0   | 0.1 | 0.1 | 0.3 | 0.5 | 0   | 0   | 0.02 | 0   | 0    | 0    | 0   | 0   | 0   | 0   | 0   | 0   | 0   | 0   | 0   | 0   | 0   | 0   | 0   | 0   | 0   |
| 511  | 0              | 0   | 0.1 | 0.2 | 0.1 | 0.1 | 0.3 | 0   | 0.02 | 0   | 0    | 0    | 0   | 0   | 0.1 | 0   | 0   | 0   | 0   | 0   | 0   | 0   | 0   | 0   | 0   | 0   | 0   |
| 512  | 0              | 0   | 0   | 0.1 | 0   | 0   | 0   | 0.1 | 0.56 | 0.2 | 0.1  | 0    | 0.1 | 0   | 0   | 0   | 0   | 0   | 0   | 0   | 0   | 0   | 0   | 0   | 0   | 0   | 0   |
| 513  | 0              | 0   | 0   | 0   | 0   | 0   | 0   | 0   | 0.78 | 0.2 | 0    | 0.02 | 0   | 0   | 0   | 0   | 0   | 0   | 0   | 0   | 0   | 0   | 0   | 0   | 0   | 0   | 0   |
| 514  | 0              | 0   | 0   | 0   | 0   | 0   | 0   | 0   | 0.23 | 0.7 | 0    | 0.04 | 0   | 0   | 0   | 0   | 0   | 0   | 0   | 0   | 0   | 0   | 0   | 0   | 0   | 0   | 0   |
| 515  | 0              | 0   | 0   | 0   | 0   | 0   | 0   | 0   | 0.12 | 0.1 | 0.6  | 0.04 | 0.1 | 0   | 0   | 0   | 0   | 0   | 0   | 0   | 0   | 0   | 0   | 0   | 0   | 0   | 0   |
| 521  | 0              | 0   | 0   | 0   | 0   | 0   | 0   | 0   | 0.02 | 0.1 | 0    | 0.71 | 0   | 0   | 0   | 0   | 0   | 0   | 0   | 0   | 0   | 0   | 0   | 0   | 0   | 0   | 0   |
| 522  | 0              | 0   | 0.1 | 0   | 0   | 0   | 0   | 0   | 0    | 0   | 0.04 | 0.3  | 0   | 0.4 | 0.1 | 0   | 0   | 0   | 0   | 0   | 0   | 0   | 0   | 0   | 0   | 0   | 0   |
| 525  | 0              | 0   | 0.1 | 0   | 0   | 0   | 0   | 0   | 0.03 | 0   | 0    | 0.07 | 0.1 | 0.1 | 0.6 | 0.1 | 0   | 0   | 0   | 0   | 0   | 0   | 0   | 0   | 0   | 0   | 0   |
| 551  | 0              | 0   | 0   | 0.4 | 0   | 0.2 | 0   | 0   | 0    | 0   | 0    | 0.2  | 0   | 0   | 0.2 | 0   | 0   | 0   | 0   | 0   | 0   | 0   | 0   | 0   | 0   | 0   | 0   |
| 552  | 0              | 0   | 0   | 1   | 0   | 0   | 0   | 0   | 0    | 0   | 0    | 0    | 0   | 0   | 0   | 0   | 0   | 0   | 0   | 0   | 0   | 0   | 0   | 0   | 0   | 0   | 0   |
| 561  | 0              | 0   | 0.1 | 0   | 0   | 0   | 0   | 0   | 0.01 | 0   | 0    | 0.04 | 0.1 | 0   | 0.3 | 0.3 | 0.1 | 0   | 0   | 0   | 0   | 0   | 0   | 0   | 0   | 0   | 0   |
| 562  | 0              | 0   | 0.1 | 0   | 0   | 0   | 0   | 0   | 0    | 0   | 0    | 0    | 0.1 | 0   | 0.3 | 0.1 | 0.2 | 0   | 0   | 0   | 0   | 0   | 0   | 0   | 0   | 0   | 0   |
| 526  | 0              | 0   | 0   | 0   | 0   | 0   | 0   | 0   | 0.07 | 0.1 | 0    | 0.64 | 0   | 0.1 | 0   | 0   | 0   | 0.1 | 0   | 0   | 0   | 0   | 0.1 | 0   | 0   | 0   | 0   |
| 537  | 0              | 0   | 0   | 0   | 0   | 0   | 0   | 0   | 0    | 0   | 0    | 0.11 | 0   | 0   | 0.1 | 0   | 0   | 0   | 0   | 0   | 0.5 | 0   | 0.4 | 0   | 0   | 0   | 0   |
| 539  | 0              | 0   | 0   | 0   | 0   | 0   | 0   | 0   | 0    | 0   | 0    | 0    | 0   | 0   | 0   | 0   | 0   | 0   | 0   | 0   | 0.3 | 0   | 0.6 | 0   | 0   | 0   | 0   |

There were only 17 recaptures of spawning cod tagged in southern New England (3 in season of release, 5 in post-spawning season, 6 in subsequent spawning season), with 76% of recaptures in the spawning area (537-539), two recaptures in 521 (Great South Channel), and single recaptures in 551 (eastern Georges Bank) and 611 (Long Island Sound).

Western Gulf of Maine winter spawners demonstrated strong spawning site fidelity (Table C2). All recaptures during the same release season (41 with reported recapture location) were recaptured in the spawning area (513-514, western Gulf of Maine). Of the 159 recaptures in the post-spawning period, 93% were in the spawning area, and 1-3% moved to Browns Bank (464), central Gulf of Maine (515), Great South Channel (521), and Georges Bank (522, 562). In subsequent spawning seasons there was 100% residence in the Gulf of Maine, 96% residence in spawning area, and 4% movement to central Gulf of Maine (515).

Table C2. Recaptures from the Northeast Regional Cod Tagging Program of cod tagged during the winter spawning season (October-January) in the western Gulf of Maine (513-514) and recaptured during the same spawning season, the post-spawning season (February-September) and subsequent spawning seasons. Colors indicate relative proportions and outlines indicate residence in area of release.

| <b>Season of Release</b>           |                               |     |     |     |     |     |     |    |     |                      |      |      |      |      |      |      |
|------------------------------------|-------------------------------|-----|-----|-----|-----|-----|-----|----|-----|----------------------|------|------|------|------|------|------|
|                                    | Recapture Area (# recaptures) |     |     |     |     |     |     |    |     | (proportion by area) |      |      |      |      |      |      |
| Rel.                               | 464                           | 513 | 514 | 515 | 521 | 522 | 562 | ?  | Sum | 464                  | 513  | 514  | 515  | 521  | 522  | 562  |
| 513                                |                               | 28  | 11  |     |     |     |     | 2  | 41  | 0                    | 0.72 | 0.28 | 0    | 0    | 0    | 0    |
| 514                                |                               |     | 2   |     |     |     |     | 2  | 4   | 0                    | 0    | 1    | 0    | 0    | 0    | 0    |
| Sum                                |                               | 28  | 13  |     |     |     |     | 4  | 45  |                      |      |      |      |      |      |      |
| <b>Post-Spawning Season</b>        |                               |     |     |     |     |     |     |    |     |                      |      |      |      |      |      |      |
| 513                                | 1                             | 114 | 27  | 2   | 4   | 3   | 1   | 10 | 162 | 0.01                 | 0.75 | 0.18 | 0.01 | 0.03 | 0.02 | 0.01 |
| 514                                |                               |     | 7   |     |     |     |     | 2  | 9   | 0                    | 0    | 1    | 0    | 0    | 0    | 0    |
| Sum                                | 1                             | 114 | 34  | 2   | 4   | 3   | 1   | 12 | 171 |                      |      |      |      |      |      |      |
| <b>Subsequent Spawning Seasons</b> |                               |     |     |     |     |     |     |    |     |                      |      |      |      |      |      |      |
| 513                                |                               | 14  | 5   | 1   |     |     |     | 2  | 22  | 0                    | 0.70 | 0.25 | 0.05 | 0    | 0    | 0    |
| 514                                |                               |     | 5   |     |     |     |     | 5  | 5   | 0                    | 0    | 1    | 0    | 0    | 0    | 0    |
| Sum                                |                               | 14  | 10  | 1   |     |     |     | 2  | 27  |                      |      |      |      |      |      |      |





Georges Bank spawners demonstrated high spawning site fidelity and dispersal in the post-spawning season (Table C5). During the release season (177 recaptures with locations), there was 98% residence on Georges Bank (522, 525, 551, 552, 561, 562), 1% movement to the western Scotian Shelf (465), 1% movement to the western Gulf of Maine (513), and 1% to the Great South Channel (521). During the post-spawning season (567 recaptures with locations), there was 71% residence on Georges Bank (522, 525, 551, 552, 561, 562), 24% movement to the Scotian Shelf-Bay of Fundy (462, 463, 464, 465, 466, 467), 3% movement to the Great South Channel (521), and 2% movement to the Gulf of Maine (511, 512, 513, 514). During subsequent spawning seasons (155 recaptures with locations), there was 87% residence on Georges Bank, 5% movement to the western Scotian Shelf and Browns Bank (463, 464), 5% movement to the Great South Channel (521), and 2% movement to the Gulf of Maine (511, 514). There was no documented movement to southern New England or the Mid Atlantic Bight.

Table C5. Recaptures from the Northeast Regional Cod Tagging Program of cod tagged during the spawning season (December-May) on Georges Bank (522, 551, 552, 561, 562) and recaptured during the same spawning season, the post-spawning season (June-November), and subsequent spawning seasons. Colors indicate relative proportions and outlines indicate residence in area of release.

| Season of Release             |      |      |      |      |      |      |      |      |      |      |      |      |      |      |      |      |       |     |     |
|-------------------------------|------|------|------|------|------|------|------|------|------|------|------|------|------|------|------|------|-------|-----|-----|
| Recapture Area (# recaptures) |      |      |      |      |      |      |      |      |      |      |      |      |      |      |      |      |       |     |     |
| Rel.                          | 462  | 463  | 464  | 465  | 466  | 467  | 511  | 512  | 513  | 514  | 521  | 522  | 525  | 551  | 561  | 562  | 526 ? | Sum |     |
| 522                           |      |      |      |      |      |      |      |      |      |      | 1    | 18   | 2    |      | 1    |      |       | 1   | 23  |
| 551                           |      |      |      |      |      |      |      |      |      |      |      |      |      |      |      |      |       |     | 0   |
| 552                           |      |      |      |      |      |      |      |      |      |      |      |      |      |      |      |      |       |     | 0   |
| 561                           |      |      |      | 1    |      |      |      |      | 1    |      |      | 5    | 5    |      | 112  | 20   |       | 10  | 154 |
| 562                           |      |      |      |      |      |      |      |      |      |      |      |      | 3    |      |      | 8    |       |     | 11  |
| Sum                           | 0    | 0    | 0    | 1    | 0    | 0    | 0    | 0    | 1    | 0    | 1    | 23   | 10   | 0    | 113  | 28   | 0     | 11  | 188 |
| Post-Spawning Season          |      |      |      |      |      |      |      |      |      |      |      |      |      |      |      |      |       |     |     |
| 522                           | 1    |      | 34   | 4    | 2    | 7    | 3    |      | 1    | 1    | 3    | 32   |      | 100  | 3    | 5    |       | 15  | 211 |
| 551                           |      |      |      | 2    |      | 1    |      |      |      |      | 1    |      |      | 1    |      |      |       |     | 5   |
| 552                           |      |      |      | 1    |      |      |      |      |      |      |      |      |      |      |      |      |       | 1   | 2   |
| 561                           | 1    | 5    | 37   | 7    | 2    | 9    |      | 1    | 3    |      | 14   | 28   | 1    | 139  | 3    | 5    |       | 15  | 270 |
| 562                           | 1    |      | 14   | 3    | 1    | 6    |      |      |      |      |      | 9    |      | 50   | 14   | 12   |       | 7   | 117 |
| Sum                           | 3    | 5    | 85   | 17   | 5    | 23   | 3    | 1    | 4    | 1    | 18   | 69   | 1    | 290  | 20   | 22   | 0     | 38  | 605 |
| Subsequent Spawning Seasons   |      |      |      |      |      |      |      |      |      |      |      |      |      |      |      |      |       |     |     |
| 522                           |      |      | 1    |      |      |      |      |      |      | 1    | 4    | 21   | 3    | 6    | 12   | 6    | 2     | 9   | 65  |
| 551                           |      |      |      |      |      |      |      |      |      |      |      |      |      |      |      |      |       |     | 0   |
| 552                           |      |      |      |      |      |      |      |      |      |      |      |      |      |      |      |      |       |     | 0   |
| 561                           |      | 1    | 3    |      |      |      | 2    |      |      |      | 4    | 28   | 5    | 3    | 5    | 2    |       | 12  | 65  |
| 562                           |      |      | 2    |      |      |      |      |      |      |      |      | 7    | 3    | 3    | 10   | 21   |       | 11  | 57  |
| Sum                           | 0    | 1    | 6    | 0    | 0    | 0    | 2    | 0    | 0    | 1    | 8    | 56   | 11   | 12   | 27   | 29   | 2     | 32  | 187 |
| Season of Release             |      |      |      |      |      |      |      |      |      |      |      |      |      |      |      |      |       |     |     |
| (proportion by area)          |      |      |      |      |      |      |      |      |      |      |      |      |      |      |      |      |       |     |     |
| Rel.                          | 462  | 463  | 464  | 465  | 466  | 467  | 511  | 512  | 513  | 514  | 521  | 522  | 525  | 551  | 561  | 562  | 526   |     |     |
| 522                           | 0    | 0    | 0    | 0    | 0    | 0    | 0    | 0    | 0    | 0    | 0.05 | 0.82 | 0.09 | 0    | 0.05 | 0    | 0     |     |     |
| 551                           |      |      |      |      |      |      |      |      |      |      |      |      |      |      |      |      |       |     |     |
| 552                           |      |      |      |      |      |      |      |      |      |      |      |      |      |      |      |      |       |     |     |
| 561                           | 0    | 0    | 0    | 0.01 | 0    | 0    | 0    | 0    | 0.01 | 0    | 0    | 0.03 | 0.03 | 0    | 0.78 | 0.14 |       | 0   |     |
| 562                           | 0    | 0    | 0    | 0    | 0    | 0    | 0    | 0    | 0    | 0    | 0    | 0    | 0.27 | 0    | 0    | 0.73 |       | 0   |     |
| Post-Spawning Season          |      |      |      |      |      |      |      |      |      |      |      |      |      |      |      |      |       |     |     |
| 522                           | 0.01 | 0    | 0.17 | 0.02 | 0.01 | 0.04 | 0.02 | 0    | 0.01 | 0.01 | 0.02 | 0.16 | 0    | 0.51 | 0.02 | 0.03 |       | 0   |     |
| 551                           | 0    | 0    | 0    | 0.40 | 0    | 0.20 | 0    | 0    | 0    | 0    | 0.20 | 0    | 0    | 0.20 | 0    | 0    |       | 0   |     |
| 552                           | 0    | 0    | 0    | 1.00 | 0    | 0    | 0    | 0    | 0    | 0    | 0    | 0    | 0    | 0    | 0    | 0    |       | 0   |     |
| 561                           | 0.00 | 0.02 | 0.15 | 0.03 | 0.01 | 0.04 | 0    | 0.00 | 0.01 | 0    | 0.05 | 0.11 | 0.00 | 0.55 | 0.01 | 0.02 |       | 0   |     |
| 562                           | 0.01 | 0    | 0.13 | 0.03 | 0.01 | 0.05 | 0    | 0    | 0    | 0    | 0    | 0.08 | 0.00 | 0.45 | 0.13 | 0.11 |       | 0   |     |
| Subsequent Spawning Seasons   |      |      |      |      |      |      |      |      |      |      |      |      |      |      |      |      |       |     |     |
| 522                           | 0    | 0    | 0.02 | 0    | 0    | 0    | 0    | 0    | 0    | 0.02 | 0.07 | 0.38 | 0.05 | 0.11 | 0.21 | 0.11 | 0.04  |     |     |
| 551                           |      |      |      |      |      |      |      |      |      |      |      |      |      |      |      |      |       |     |     |
| 552                           |      |      |      |      |      |      |      |      |      |      |      |      |      |      |      |      |       |     |     |
| 561                           | 0    | 0.02 | 0.06 | 0    | 0    | 0    | 0.04 | 0    | 0    | 0    | 0.08 | 0.53 | 0.09 | 0.06 | 0.09 | 0.04 |       | 0   |     |
| 562                           | 0    | 0    | 0.04 | 0    | 0    | 0    | 0.00 | 0    | 0    | 0    | 0    | 0.15 | 0.07 | 0.07 | 0.22 | 0.46 |       | 0   |     |

Bay of Fundy spawners demonstrated high spawning site fidelity (Table C6). There was 100% residence in the spawning area (Bay of Fundy; 466, 467) during the release season (126 recaptures with locations). During the post-spawning season (503 recaptures with locations), there was 94% residence in the spawning area (466, 467), 4% movement to Georges Bank (522, 551), and 3% movement to the Gulf of Maine (511, 513). During subsequent spawning seasons 128 recaptures with locations, there was 94% residence in the spawning area, 3% movement to the Gulf of Maine (511, 513), 2% to Georges Bank (522, 551, 561), and 1% to Mid Atlantic (621, off DE-MD)

Table C6. Recaptures from the Northeast Regional Cod Tagging Program of cod tagged during the spawning season (January-May) in the Bay of Fundy (466-467) and recaptured during the same spawning season, the post-spawning season (June-December), and subsequent spawning seasons. Colors indicate relative proportions and outlines indicate residence in area of release.

| Season of Release           |                               |      |      |      |      |      |      |      |      |      |      |      |    |     |
|-----------------------------|-------------------------------|------|------|------|------|------|------|------|------|------|------|------|----|-----|
|                             | Recapture Area (# recaptures) |      |      |      |      |      |      |      |      |      |      |      |    |     |
| Rel.                        | 462                           | 463  | 464  | 465  | 466  | 467  | 511  | 513  | 522  | 551  | 561  | 621  | ?  | Sum |
| 466                         |                               |      |      |      | 44   | 16   |      |      |      |      |      |      |    | 60  |
| 467                         |                               |      |      |      | 32   | 34   |      |      |      |      |      |      | 1  | 67  |
| Sum                         | 0                             | 0    | 0    | 0    | 76   | 50   | 0    | 0    | 0    | 0    | 0    | 0    | 0  | 127 |
| Post-Spawning Season        |                               |      |      |      |      |      |      |      |      |      |      |      |    |     |
| 466                         |                               |      |      | 8    | 97   | 179  | 5    | 2    | 3    | 9    |      |      | 12 | 315 |
| 467                         |                               | 1    | 5    | 3    | 60   | 119  | 5    | 1    | 1    | 5    |      |      | 5  | 205 |
| Sum                         | 0                             | 1    | 5    | 11   | 157  | 298  | 10   | 3    | 4    | 14   | 0    | 0    | 17 | 520 |
| Subsequent Spawning Seasons |                               |      |      |      |      |      |      |      |      |      |      |      |    |     |
| 466                         | 1                             |      | 9    | 11   | 31   | 29   | 1    | 1    | 1    |      | 1    | 1    | 4  | 90  |
| 467                         |                               |      | 6    | 10   | 14   | 9    | 1    | 1    |      | 1    |      |      | 5  | 47  |
| Sum                         | 1                             | 0    | 15   | 21   | 45   | 38   | 2    | 2    | 1    | 1    | 1    | 1    | 9  | 137 |
| Season of Release           |                               |      |      |      |      |      |      |      |      |      |      |      |    |     |
|                             | (proportion by area)          |      |      |      |      |      |      |      |      |      |      |      |    |     |
| Rel.                        | 462                           | 463  | 464  | 465  | 466  | 467  | 511  | 513  | 522  | 551  | 561  | 621  |    |     |
| 466                         | 0                             | 0    | 0    | 0    | 0.73 | 0.27 | 0    | 0    | 0    | 0    | 0    | 0    | 0  |     |
| 467                         | 0                             | 0    | 0    | 0    | 0.48 | 0.52 | 0    | 0    | 0    | 0    | 0    | 0    | 0  |     |
| Post-Spawning Season        |                               |      |      |      |      |      |      |      |      |      |      |      |    |     |
| 466                         | 0                             | 0    | 0    | 0    | 0    | 1    | 0.02 | 0.01 | 0.01 | 0.03 | 0    | 0    |    |     |
| 467                         | 0                             | 0.01 | 0.03 | 0.02 | 0.3  | 0.60 | 0.03 | 0.01 | 0.01 | 0.03 | 0    | 0    |    |     |
| Subsequent Spawning Seasons |                               |      |      |      |      |      |      |      |      |      |      |      |    |     |
| 466                         | 0.01                          | 0    | 0.10 | 0.13 | 0.36 | 0.34 | 0.01 | 0.01 | 0.01 | 0    | 0.01 | 0.01 |    |     |
| 467                         | 0                             | 0    | 0.14 | 0.24 | 0.33 | 0.21 | 0.02 | 0.02 | 0    | 0.02 | 0    | 0    |    |     |

### Appendix D. Massachusetts Marine Fisheries Institute

There were 1,814 reported recaptures with recapture position from the Massachusetts Marine Fisheries Institute tagging during 2000-2014, and some at large for up to ten years. Regional residence was generally high, but there was also some substantial movements between regions (Table D1a). Regional residence was 91% in the western Gulf of Maine, 50% in the Great South Channel, 66% on Georges Bank, 92% in southern New England, and 100% in the Mid-Atlantic Bight. Substantial regional movements were from the Great South Channel to the western Gulf of Maine (34%) and to southern New England (12%), and from Georges Bank to the Great South Channel (16%) and the Scotian Shelf (9%).

Table D1a. All tag recaptures from the Massachusetts Marine Fisheries Institute by statistical area of release (Rel.) and recapture. Colors indicate geographic regions (green: western Gulf of Maine; white: Great South Channel; orange: Georges Bank; red: S. New England-Mid-Atlantic) and outlines indicate regional residence.

| Rel. | Release Area |     |     |     |      |     |     |     |     |     |     |     |     |     |     |     |     |     |     |     |     |     |   |  |      |        | Sum |
|------|--------------|-----|-----|-----|------|-----|-----|-----|-----|-----|-----|-----|-----|-----|-----|-----|-----|-----|-----|-----|-----|-----|---|--|------|--------|-----|
|      | 463          | 464 | 512 | 513 | 514  | 515 | 521 | 522 | 525 | 551 | 561 | 562 | 526 | 537 | 538 | 539 | 611 | 612 | 613 | 614 | 621 | 626 | ? |  |      |        |     |
| 513  |              |     | 22  | 13  |      |     | 1   |     |     |     | 1   |     |     |     | 1   |     |     |     |     |     |     |     |   |  |      | 38     |     |
| 514  |              |     | 2   | 107 | 1104 | 1   | 74  | 2   | 6   |     |     |     |     | 1   | 32  |     |     |     |     |     |     |     |   |  |      | 3 1332 |     |
| 521  |              |     |     | 7   | 35   |     | 62  | 5   |     |     |     |     | 3   | 1   | 2   | 9   |     | 1   |     |     |     |     |   |  |      | 125    |     |
| 522  |              |     |     |     |      |     | 1   | 1   | 1   | 1   |     |     |     |     |     |     |     |     |     |     |     |     |   |  |      | 4      |     |
| 525  |              |     |     |     |      |     | 1   |     |     |     |     |     |     |     |     |     |     |     |     |     |     |     |   |  |      | 1      |     |
| 561  | 1            | 2   |     |     |      | 1   | 3   | 3   | 1   | 10  | 3   | 1   |     |     | 2   |     |     |     |     |     |     |     |   |  |      | 27     |     |
| 526  |              |     |     |     |      |     |     |     |     |     |     |     | 5   | 1   | 1   |     |     |     |     |     |     |     |   |  |      | 7      |     |
| 537  |              |     |     | 1   |      |     | 6   |     |     |     |     |     |     | 67  | 103 |     | 1   | 1   | 2   |     |     |     |   |  |      | 181    |     |
| 539  |              |     |     |     |      |     | 7   | 1   |     |     |     |     |     | 27  | 1   | 33  |     | 1   | 1   |     |     |     |   |  |      | 71     |     |
| 621  |              |     |     |     |      |     |     |     |     |     |     |     |     |     |     |     |     |     |     |     |     | 18  | 2 |  |      | 20     |     |
| 625  |              |     |     |     |      |     |     |     |     |     |     |     |     |     |     |     |     |     |     | 1   | 2   |     |   |  |      | 3      |     |
| 626  |              |     |     |     |      |     |     |     |     |     |     |     |     |     |     |     |     |     |     |     |     | 3   | 2 |  |      | 5      |     |
| ?    |              |     |     |     | 1    |     |     |     |     |     |     |     |     |     |     |     |     |     |     |     |     |     |   |  |      | 1      |     |
| Sum  | 1            | 2   | 2   | 137 | 1153 | 2   | 155 | 12  | 7   | 11  | 5   | 1   | 8   | 97  | 39  | 145 | 1   | 3   | 3   | 1   | 23  | 4   | 3 |  | 1815 |        |     |



Substantial residence in statistical areas (Table D1b) was in southern ME-NH (513), southwest Gulf of Maine (514), Great South Channel (521), Nantucket Shoals (526), and off Delaware Bay (621). Substantial movement (>50%) was from offshore southern New England (537) to RI Sound (539) and from off MD (525, 526) to off DE (621).

Table D1b. All tag recaptures from the Massachusetts Marine Fisheries Institute by statistical area of release (Rel.) and recapture, expressed as the proportion of known-area recaptures from each release area. Outlines indicate residence in each area.

| Rel. | Release Area |      |      |      |      |      |      |      |      |      |      |      |      |      |      |      |      |      |      |      |      |      |
|------|--------------|------|------|------|------|------|------|------|------|------|------|------|------|------|------|------|------|------|------|------|------|------|
|      | 463          | 464  | 512  | 513  | 514  | 515  | 521  | 522  | 525  | 551  | 561  | 562  | 526  | 537  | 538  | 539  | 611  | 612  | 613  | 614  | 621  | 626  |
| 513  | 0            | 0    | 0    | 0.58 | 0.34 | 0    | 0.03 | 0    | 0    | 0    | 0.03 | 0    | 0    | 0.03 | 0    | 0    | 0    | 0    | 0    | 0    | 0    | 0    |
| 514  | 0            | 0    | 0.00 | 0.08 | 0.83 | 0.00 | 0.06 | 0.00 | 0.00 | 0    | 0    | 0    | 0.00 | 0.02 | 0    | 0    | 0    | 0    | 0    | 0    | 0    | 0    |
| 521  | 0            | 0    | 0    | 0.06 | 0.28 | 0    | 0.50 | 0.04 | 0    | 0    | 0    | 0.02 | 0.01 | 0.02 | 0.07 | 0    | 0.01 | 0    | 0    | 0    | 0    | 0    |
| 522  | 0            | 0    | 0    | 0    | 0    | 0    | 0.25 | 0.25 | 0    | 0.25 | 0.25 | 0    | 0    | 0    | 0    | 0    | 0    | 0    | 0    | 0    | 0    | 0    |
| 525  | 0            | 0    | 0    | 0    | 0    | 0    | 1.00 | 0    | 0    | 0    | 0    | 0    | 0    | 0    | 0    | 0    | 0    | 0    | 0    | 0    | 0    | 0    |
| 561  | 0.04         | 0.07 | 0    | 0    | 0    | 0.04 | 0.11 | 0.11 | 0.04 | 0.37 | 0.11 | 0    | 0    | 0    | 0.07 | 0    | 0    | 0    | 0    | 0    | 0    | 0    |
| 526  | 0            | 0    | 0    | 0    | 0    | 0    | 0    | 0    | 0    | 0    | 0    | 0    | 0.71 | 0.14 | 0.14 | 0    | 0    | 0    | 0    | 0    | 0    | 0    |
| 537  | 0            | 0    | 0    | 0.01 | 0    | 0    | 0.03 | 0    | 0    | 0    | 0    | 0    | 0    | 0.37 | 0    | 0.57 | 0.01 | 0.01 | 0.01 | 0    | 0    | 0    |
| 539  | 0            | 0    | 0    | 0    | 0    | 0    | 0.10 | 0.01 | 0    | 0    | 0    | 0    | 0    | 0.38 | 0.01 | 0.46 | 0    | 0.01 | 0.01 | 0    | 0    | 0    |
| 621  | 0            | 0    | 0    | 0    | 0    | 0    | 0    | 0    | 0    | 0    | 0    | 0    | 0    | 0    | 0    | 0    | 0    | 0    | 0    | 0    | 0.90 | 0.10 |
| 625  | 0            | 0    | 0    | 0    | 0    | 0    | 0    | 0    | 0    | 0    | 0    | 0    | 0    | 0    | 0    | 0    | 0    | 0    | 0    | 0.33 | 0.67 | 0    |
| 626  | 0            | 0    | 0    | 0    | 0    | 0    | 0    | 0    | 0    | 0    | 0    | 0    | 0    | 0    | 0    | 0    | 0    | 0    | 0    | 0    | 0.60 | 0.40 |

Western Gulf of Maine winter spawners demonstrated strong spawning site fidelity (Table D2). Of the 54 recaptures during the same release season, 98% were recaptured in the spawning area (514, western Gulf of Maine), with some movement (2%) to the central Gulf of Maine (515). Of the 132 recaptures in the post-spawning period, 92% were in western Gulf of Maine (513-514), 2% moved to the Great South Channel (521), and 4% moved to southern New England. In subsequent spawning seasons, there was 89% residence in the spawning area, 5% movement to the Great South Channel (521), and 5% movement to southern New England (538).

Table D2. Recaptures from the Massachusetts Marine Fisheries Institute of cod tagged during the winter spawning season (October-January) in the western Gulf of Maine (513-514) and recaptured during the same spawning season, the post-spawning season (February-September) and subsequent spawning seasons. Colors indicate relative proportions and outlines indicate residence in area of release.

| Season of Release                  |     | Recapture Area (# recaptures) |     |     |     |     |     |   | (proportion by area) |      |      |      |      |      |      |      |
|------------------------------------|-----|-------------------------------|-----|-----|-----|-----|-----|---|----------------------|------|------|------|------|------|------|------|
| Rel.                               | 513 | 514                           | 515 | 521 | 522 | 537 | 538 | ? | Sum                  | 513  | 514  | 515  | 521  | 522  | 537  | 538  |
| 514                                |     | 53                            | 1   |     |     |     |     |   | 54                   | 0    | 0.98 | 0.02 | 0    | 0    | 0    | 0    |
| <b>Post-Spawning Season</b>        |     |                               |     |     |     |     |     |   |                      |      |      |      |      |      |      |      |
| 514                                | 7   | 114                           |     | 3   | 1   | 1   | 5   | 1 | 132                  | 0.05 | 0.87 | 0    | 0.02 | 0.01 | 0.01 | 0.04 |
| <b>Subsequent Spawning Seasons</b> |     |                               |     |     |     |     |     |   |                      |      |      |      |      |      |      |      |
| 514                                | 2   | 30                            |     | 2   |     |     | 2   |   | 36                   | 0.06 | 0.83 | 0    | 0.06 | 0    | 0    | 0.06 |

Western Gulf of Maine spring spawners also demonstrated high spawning site fidelity (Table D3). Of the 389 recaptures during the same release season, 96% were recaptured in the spawning area (513-514, western Gulf of Maine), with some movement (8%) to the Great South Channel (521). Of the 411 recaptures in the post-spawning period, 88% were in the spawning area, 8% moved to the Great South Channel (521), and 4% moved to southern New England. In subsequent spawning seasons there was 92% residence in the spawning area, and 5% movement to the Great South Channel (521).

Table D3. Recaptures from the Massachusetts Marine Fisheries Institute of cod tagged during the spring spawning season (April-July) in the western Gulf of Maine (513-514) and recaptured during the same spawning season, the post-spawning season (August-March) and subsequent spawning seasons. Colors indicate relative proportions and outlines indicate residence in area of release.

| Season of Release                  |                               |     |     |     |     |     |     |   |                      |      |      |      |      |      |      |      |
|------------------------------------|-------------------------------|-----|-----|-----|-----|-----|-----|---|----------------------|------|------|------|------|------|------|------|
| Rel.                               | Recapture Area (# recaptures) |     |     |     |     |     |     |   | (proportion by area) |      |      |      |      |      |      |      |
|                                    | 512                           | 513 | 514 | 521 | 525 | 538 | 561 | ? | Sum                  | 512  | 513  | 514  | 521  | 525  | 538  | 561  |
| 513                                |                               | 9   | 3   |     |     |     |     |   | 12                   | 0    | 0.75 | 0.25 | 0    | 0    | 0    | 0    |
| 514                                | 1                             | 19  | 342 | 10  |     | 5   |     |   | 377                  | 0.00 | 0.05 | 0.91 | 0.03 | 0    | 0.01 | 0    |
| Sum                                | 1                             | 28  | 345 | 10  |     | 5   |     |   | 389                  |      |      |      |      |      |      |      |
| <b>Post-Spawning Seasons</b>       |                               |     |     |     |     |     |     |   |                      |      |      |      |      |      |      |      |
| 513                                |                               | 8   | 9   | 1   |     | 1   |     |   | 19                   | 0    | 0.42 | 0.47 | 0.05 | 0    | 0.05 | 0    |
| 514                                |                               | 53  | 290 | 31  | 2   | 16  |     | 1 | 393                  | 0    | 0.14 | 0.74 | 0.08 | 0.01 | 0.04 | 0    |
| Sum                                |                               | 61  | 299 | 32  | 2   | 17  |     | 1 | 412                  |      |      |      |      |      |      |      |
| <b>Subsequent Spawning Seasons</b> |                               |     |     |     |     |     |     |   |                      |      |      |      |      |      |      |      |
| 513                                |                               | 5   | 1   |     |     |     | 1   |   | 7                    | 0    | 0.71 | 0.14 | 0    | 0    | 0    | 0.14 |
| 514                                |                               | 14  | 124 | 8   | 1   | 2   |     | 1 | 150                  | 0    | 0.09 | 0.83 | 0.05 | 0.01 | 0.01 | 0    |
| Sum                                |                               | 19  | 125 | 8   | 1   | 2   | 1   | 1 | 157                  |      |      |      |      |      |      |      |

Southern New England spawners demonstrated high spawning site fidelity (Table D4). During the release season (139 recaptures) there was 99% residence in the spawning area (537, 538, 539), with some movement to the Mid- Atlantic Bight (611, 613). During the post-spawning season (42 recaptures), there was 74% residence in southern New England, 19% movement to the Great South Channel (521), and 5% movement to the Mid-Atlantic Bight (612, 613). During subsequent spawning seasons (19 recaptures), there was 95% residence in southern New England and 5% movement to the Great South Channel (521).

Table D4. Recaptures from the Massachusetts Marine Fisheries Institute of cod tagged during the spawning season (December-May) off southern New England (537, 539) and recaptured during the same spawning season, the post-spawning season (November-March) and subsequent spawning seasons. Colors indicate relative proportions and outlines indicate residence in area of release.

| <b>Season of Release</b>           |                               |     |     |     |     |     |     |     |     |                      |      |      |      |      |      |      |      |
|------------------------------------|-------------------------------|-----|-----|-----|-----|-----|-----|-----|-----|----------------------|------|------|------|------|------|------|------|
|                                    | Recapture Area (# recaptures) |     |     |     |     |     |     |     |     | (proportion by area) |      |      |      |      |      |      |      |
| Rel.                               | 513                           | 521 | 537 | 538 | 539 | 611 | 612 | 613 | Sum | 513                  | 521  | 537  | 538  | 539  | 611  | 612  | 613  |
| 537                                |                               |     | 52  |     | 82  | 1   |     | 1   | 136 | 0                    | 0    | 0.39 | 0    | 0.61 | 0.01 | 0    | 0.01 |
| 539                                |                               |     |     |     | 3   |     |     |     | 3   | 0                    | 0    | 0    | 0    | 1.00 | 0    | 0    | 0    |
| Sum                                |                               |     | 52  |     | 85  | 1   |     | 1   | 139 |                      |      |      |      |      |      |      |      |
| <b>Post-Spawning Season</b>        |                               |     |     |     |     |     |     |     |     |                      |      |      |      |      |      |      |      |
| 537                                | 1                             | 6   | 8   |     | 14  |     | 1   | 1   | 31  | 0.03                 | 0.20 | 0.27 | 0    | 0.47 | 0    | 0.03 | 0.03 |
| 539                                |                               | 2   | 3   | 1   | 6   |     |     |     | 12  | 0                    | 0.17 | 0.25 | 0.08 | 0.50 | 0    | 0    | 0    |
| Sum                                | 1                             | 8   | 11  | 1   | 20  |     | 1   | 1   | 43  |                      |      |      |      |      |      |      |      |
| <b>Subsequent Spawning Seasons</b> |                               |     |     |     |     |     |     |     |     |                      |      |      |      |      |      |      |      |
| 537                                |                               |     | 7   |     | 7   |     |     |     | 14  | 0                    | 0    | 0.50 | 0    | 0.50 | 0    | 0    | 0    |
| 539                                |                               | 1   |     |     | 4   |     |     |     | 5   | 0                    | 0.20 | 0    | 0    | 0.80 | 0    | 0    | 0    |
| Sum                                |                               | 1   | 7   |     | 11  |     |     |     | 19  |                      |      |      |      |      |      |      |      |

From the Massachusetts Marine Fisheries Institute cod tagging, only 43 Cape Cod spawners tagged during the spawning season were recaptured, and 49% were recaptured in the spawning area (521). Only one cod tagged on Georges Bank during the spawning season was recaptured.

## Appendix E. Canada Department of Fisheries 2001-2004 Tagging Data

Canada DFO tagged approximately 10,000 cod on the Scotian Shelf in 2001-2004 that are not included in the Northeast Regional Cod Tagging Program database. There were 472 recaptures reported, and 445 were reported with recapture position, some at large for up to five years. Residence was 95% on the Scotian Shelf and Bay of Fundy (Table E1a-b). Within the region, there was 84% residence on the western Scotian Shelf (462, 463), with 7% movement to Browns Bank (464), 4% to the Bay of Fundy (465, 466, 467), 3% to Georges Bank (525, 551, 561, 562), and 2% movement to the east (461). There was 68% residence on Browns Bank with some movement to the Scotian Shelf, Bay of Fundy, and Georges Bank. There was low residence in the Bay of Fundy (41% in 465 and 466) with 47% movement to Browns Bank and the Scotian Shelf and 12% movement to Georges Bank.

Table E1a. All tag recaptures from Canada DFO 2001-2004 by statistical area of release (Rel.) and recapture. Colors indicate geographic regions (blue: Scotian Shelf-Bay of Fundy; green: Gulf of Maine; dark green: western Gulf of Maine; orange: Georges Bank; red: S. New England-Mid-Atlantic) and outlines indicate regional residence.

|      | Recapture Area |     |     |     |     |     |     |     |     |     |     |     |    |     |
|------|----------------|-----|-----|-----|-----|-----|-----|-----|-----|-----|-----|-----|----|-----|
| Rel. | 461            | 462 | 463 | 464 | 465 | 466 | 467 | 511 | 525 | 551 | 561 | 562 | ?  | Sum |
| 462  |                | 91  | 11  | 2   | 2   |     |     |     |     | 1   |     | 1   | 9  | 117 |
| 463  | 6              | 35  | 144 | 22  | 8   | 2   | 1   | 1   | 1   | 5   | 1   | 2   | 12 | 240 |
| 464  | 1              | 3   | 2   | 28  | 3   | 2   |     |     |     | 2   |     |     | 3  | 44  |
| 465  |                | 2   | 18  | 12  | 24  | 4   |     |     |     | 4   | 3   | 1   | 3  | 71  |
| Sum  | 7              | 131 | 175 | 64  | 37  | 8   | 1   | 1   | 1   | 12  | 4   | 4   | 27 | 472 |

Table E1b. All tag recaptures from Canada DFO 2001-2004 by statistical area of release (Rel.) and recapture, expressed as the proportion of known-area recaptures from each release area. Outlines indicate residence in each area.

|      | Recapture Area |      |      |      |      |      |      |      |      |      |      |      |  |
|------|----------------|------|------|------|------|------|------|------|------|------|------|------|--|
| Rel. | 461            | 462  | 463  | 464  | 465  | 466  | 467  | 511  | 525  | 551  | 561  | 562  |  |
| 462  | 0              | 0.84 | 0.10 | 0.02 | 0.02 | 0    | 0    | 0    | 0    | 0.01 | 0    | 0.01 |  |
| 463  | 0.03           | 0.15 | 0.63 | 0.10 | 0.04 | 0.01 | 0.00 | 0.00 | 0.00 | 0.02 | 0.00 | 0.01 |  |
| 464  | 0.02           | 0.07 | 0.05 | 0.68 | 0.07 | 0.05 | 0    | 0    | 0    | 0.05 | 0    | 0    |  |
| 465  | 0              | 0.03 | 0.26 | 0.18 | 0.35 | 0.06 | 0    | 0    | 0    | 0.06 | 0.04 | 0.01 |  |



## Appendix F. Massachusetts Bay Cod Conservation Zone

There were 155 reported recaptures from the Massachusetts Spring Cod Conservation Zone (514) tagging during 2010-2013, with some at large for up to two years. Residence in the western Gulf of Maine (513, 514) was high (92%), with 7% movement to the Great South Channel (521; Table F1). Western Gulf of Maine spring spawners also demonstrated high spawning site fidelity. Of the 48 recaptures during the same release season, 94% were recaptured in the spawning area, with 4% movement to the Great South Channel. Of the 76 recaptures in the post-spawning period, 89% were in the spawning area, 11% moved to the Great South Channel. In subsequent spawning seasons there was 96% residence in the spawning area, and 4% movement to the Great South Channel.

Table F1. Recaptures of cod tagged in the Massachusetts Spring Cod Conservation Zone during the spring spawning season (April-July) in the western Gulf of Maine (513-514) and recaptured during the same spawning season, the post-spawning season (August-March) and subsequent spawning seasons. Colors indicate relative proportions and outlines indicate residence in area of release.

|                                    | Recapture Area (# recaps) |     |     |     |     | (proportion by area) |      |      |      |
|------------------------------------|---------------------------|-----|-----|-----|-----|----------------------|------|------|------|
| <b>All Recaptures</b>              |                           |     |     |     |     |                      |      |      |      |
| Rel.                               | 512                       | 513 | 514 | 521 | Sum | 512                  | 513  | 514  | 521  |
| 513                                |                           |     | 1   |     | 1   | 0                    | 0    | 1.00 | 0    |
| 514                                | 1                         | 32  | 111 | 11  | 155 | 0.01                 | 0.21 | 0.72 | 0.07 |
| Sum                                | 1                         | 32  | 112 | 11  | 156 |                      |      |      |      |
| <b>Season of Release</b>           |                           |     |     |     |     |                      |      |      |      |
| 514                                | 1                         | 8   | 37  | 2   | 48  | 0.02                 | 0.17 | 0.77 | 0.04 |
| <b>Post-Spawng Season</b>          |                           |     |     |     |     |                      |      |      |      |
| 513                                |                           |     | 1   |     | 1   | 0                    | 0    | 1.00 | 0    |
| 514                                |                           | 19  | 48  | 8   | 75  | 0                    | 0.25 | 0.64 | 0.11 |
| Sum                                |                           | 19  | 49  | 8   | 76  |                      |      |      |      |
| <b>Subsequent Spawning Seasons</b> |                           |     |     |     |     |                      |      |      |      |
| 514                                |                           | 4   | 22  | 1   | 27  | 0                    | 0.15 | 0.81 | 0.04 |

## Appendix G. Combined Tagging Data

Tagging data from Canada Department of Fisheries and Oceans 1994 tagging, Northeast Regional Cod Tagging Program, the Massachusetts Marine Fisheries Institute and the Massachusetts Spring Cod Conservation Zone were combined for aggregate and seasonal analyses. There were 8,351 reported recaptures with recapture position. Regional residence was generally high, but there was also some substantial regional movements (Table G1a). Regional residence was 88% in the Bay of Fundy, 92% in the Gulf of Maine, 69% in the Great South Channel, 76% on Georges Bank, 88% in southern New England, and 100% in the Mid-Atlantic Bight. Substantial regional movements (>10%) were from the Great South Channel to the Gulf of Maine (17%), and from Georges Bank to Scotian Shelf and Bay of Fundy (22%).

Table G1a. All tag recaptures from the Northeast Regional Cod Tagging Program by statistical area of release (Rel.) and recapture. Colors indicate geographic regions (dark blue: Scotian Shelf; light blue: Bay of Fundy; green: Gulf of Maine; dark green: western Gulf of Maine; white: Cape Cod; orange: Georges Bank; red: southern New England-Mid Atlantic) and outlines indicate regional residence.

| Rel. | Recapture Area |     |     |     |     |     |     |     |     |      |      |     |      |     |     |     |     |     |     |     |     |     |     |     |     |     | Sum |     |     |     |      |      |
|------|----------------|-----|-----|-----|-----|-----|-----|-----|-----|------|------|-----|------|-----|-----|-----|-----|-----|-----|-----|-----|-----|-----|-----|-----|-----|-----|-----|-----|-----|------|------|
|      | 461            | 462 | 463 | 464 | 465 | 466 | 467 | 511 | 512 | 513  | 514  | 515 | 521  | 522 | 525 | 551 | 552 | 561 | 562 | 526 | 537 | 538 | 539 | 611 | 612 | 613 |     | 614 | 615 | 616 | 621  | 626  |
| 462  | 0              | 91  | 11  | 2   | 2   | 0   | 0   | 0   | 0   | 0    | 0    | 0   | 0    | 0   | 0   | 0   | 1   | 0   | 0   | 1   | 0   | 0   | 0   | 0   | 0   | 0   | 0   | 0   | 0   | 0   | 0    | 108  |
| 463  | 6              | 35  | 148 | 22  | 9   | 2   | 1   | 1   | 0   | 0    | 0    | 0   | 0    | 0   | 1   | 5   | 0   | 1   | 2   | 0   | 0   | 0   | 0   | 0   | 0   | 0   | 0   | 0   | 0   | 0   | 233  |      |
| 464  | 1              | 3   | 2   | 28  | 3   | 2   | 0   | 0   | 0   | 0    | 0    | 0   | 0    | 0   | 0   | 2   | 0   | 0   | 0   | 0   | 0   | 0   | 0   | 0   | 0   | 0   | 0   | 0   | 0   | 0   | 41   |      |
| 465  | 0              | 2   | 19  | 14  | 28  | 4   | 0   | 0   | 0   | 0    | 0    | 0   | 0    | 0   | 0   | 4   | 0   | 3   | 1   | 0   | 0   | 0   | 0   | 0   | 0   | 0   | 0   | 0   | 0   | 0   | 75   |      |
| 466  | 0              | 1   | 0   | 9   | 19  | 172 | 224 | 6   | 0   | 3    | 0    | 0   | 0    | 4   | 0   | 9   | 0   | 1   | 0   | 0   | 0   | 0   | 0   | 0   | 0   | 0   | 0   | 0   | 1   | 0   | 449  |      |
| 467  | 0              | 0   | 1   | 22  | 28  | 135 | 203 | 16  | 3   | 8    | 3    | 0   | 1    | 4   | 1   | 11  | 0   | 0   | 0   | 0   | 0   | 0   | 0   | 0   | 0   | 0   | 0   | 0   | 0   | 0   | 436  |      |
| 511  | 0              | 0   | 0   | 17  | 30  | 10  | 7   | 40  | 0   | 2    | 2    | 0   | 0    | 1   | 0   | 8   | 0   | 4   | 0   | 0   | 0   | 0   | 0   | 0   | 0   | 0   | 0   | 0   | 0   | 0   | 121  |      |
| 512  | 0              | 0   | 0   | 0   | 1   | 0   | 0   | 0   | 1   | 10   | 4    | 1   | 0    | 1   | 0   | 0   | 0   | 0   | 0   | 0   | 0   | 0   | 0   | 0   | 0   | 0   | 0   | 0   | 0   | 0   | 18   |      |
| 513  | 0              | 0   | 0   | 3   | 1   | 2   | 1   | 0   | 0   | 1313 | 301  | 19  | 32   | 14  | 0   | 3   | 0   | 1   | 1   | 1   | 0   | 1   | 0   | 0   | 0   | 0   | 0   | 0   | 0   | 0   | 1693 |      |
| 514  | 0              | 0   | 0   | 0   | 0   | 0   | 0   | 0   | 3   | 161  | 1285 | 13  | 78   | 2   | 6   | 0   | 0   | 0   | 0   | 0   | 1   | 32  | 0   | 0   | 0   | 0   | 0   | 0   | 0   | 0   | 1581 |      |
| 515  | 0              | 0   | 0   | 5   | 1   | 0   | 1   | 0   | 1   | 16   | 11   | 76  | 6    | 14  | 1   | 1   | 0   | 1   | 0   | 0   | 0   | 0   | 0   | 0   | 0   | 0   | 0   | 0   | 0   | 0   | 134  |      |
| 521  | 0              | 0   | 0   | 3   | 1   | 2   | 1   | 0   | 0   | 40   | 349  | 3   | 1588 | 100 | 39  | 20  | 0   | 12  | 6   | 42  | 21  | 5   | 33  | 2   | 6   | 7   | 0   | 2   | 1   | 2   | 0    | 2285 |
| 522  | 0              | 1   | 0   | 35  | 4   | 2   | 7   | 3   | 0   | 1    | 2    | 0   | 11   | 72  | 5   | 107 | 0   | 17  | 11  | 2   | 0   | 0   | 0   | 0   | 0   | 0   | 0   | 0   | 0   | 0   | 0    | 280  |
| 525  | 0              | 0   | 0   | 2   | 0   | 0   | 0   | 0   | 0   | 1    | 0    | 0   | 3    | 2   | 3   | 17  | 0   | 2   | 1   | 0   | 0   | 0   | 0   | 0   | 0   | 0   | 0   | 0   | 0   | 0   | 0    | 31   |
| 551  | 0              | 0   | 0   | 0   | 4   | 0   | 1   | 0   | 0   | 0    | 0    | 0   | 1    | 0   | 0   | 4   | 0   | 0   | 0   | 0   | 0   | 0   | 0   | 0   | 0   | 0   | 0   | 0   | 0   | 0   | 0    | 10   |
| 552  | 3              | 8   | 20  | 14  | 19  | 4   | 0   | 2   | 0   | 0    | 1    | 1   | 1    | 2   | 0   | 77  | 23  | 3   | 0   | 0   | 0   | 0   | 0   | 0   | 0   | 0   | 0   | 0   | 0   | 0   | 0    | 178  |
| 561  | 0              | 1   | 9   | 54  | 9   | 4   | 10  | 2   | 1   | 5    | 0    | 1   | 25   | 77  | 14  | 177 | 0   | 157 | 32  | 0   | 0   | 2   | 0   | 0   | 0   | 0   | 0   | 0   | 0   | 0   | 0    | 580  |
| 562  | 0              | 1   | 0   | 19  | 3   | 1   | 6   | 0   | 0   | 0    | 0    | 0   | 2    | 16  | 6   | 61  | 5   | 24  | 43  | 0   | 0   | 0   | 0   | 0   | 0   | 0   | 0   | 0   | 0   | 0   | 0    | 187  |
| 526  | 0              | 0   | 0   | 0   | 0   | 0   | 0   | 0   | 1   | 1    | 0    | 9   | 0    | 1   | 0   | 0   | 0   | 0   | 0   | 7   | 1   | 1   | 1   | 0   | 0   | 0   | 0   | 0   | 0   | 0   | 0    | 22   |
| 537  | 0              | 0   | 0   | 0   | 0   | 0   | 0   | 0   | 1   | 0    | 0    | 8   | 0    | 0   | 1   | 0   | 0   | 0   | 0   | 0   | 76  | 0   | 110 | 1   | 1   | 2   | 0   | 0   | 0   | 0   | 0    | 200  |
| 539  | 0              | 0   | 0   | 0   | 0   | 0   | 0   | 0   | 0   | 0    | 0    | 0   | 7    | 1   | 0   | 0   | 0   | 0   | 0   | 0   | 35  | 1   | 47  | 1   | 1   | 1   | 0   | 0   | 0   | 0   | 0    | 94   |
| 621  | 0              | 0   | 0   | 0   | 0   | 0   | 0   | 0   | 0   | 0    | 0    | 0   | 0    | 0   | 0   | 0   | 0   | 0   | 0   | 0   | 0   | 0   | 0   | 0   | 0   | 0   | 0   | 0   | 0   | 18  | 2    | 20   |
| 625  | 0              | 0   | 0   | 0   | 0   | 0   | 0   | 0   | 0   | 0    | 0    | 0   | 0    | 0   | 0   | 0   | 0   | 0   | 0   | 0   | 0   | 0   | 0   | 0   | 0   | 0   | 1   | 0   | 0   | 2   | 0    | 3    |
| 626  | 0              | 0   | 0   | 0   | 0   | 0   | 0   | 0   | 0   | 0    | 0    | 0   | 0    | 0   | 0   | 0   | 0   | 0   | 0   | 0   | 0   | 0   | 0   | 0   | 0   | 0   | 0   | 0   | 3   | 2   | 0    | 5    |
| Sum  | 3              | 12  | 35  | 185 | 125 | 334 | 469 | 69  | 9   | 1563 | 1960 | 114 | 1772 | 310 | 76  | 496 | 28  | 222 | 94  | 52  | 134 | 42  | 191 | 4   | 8   | 10  | 1   | 2   | 1   | 26  | 4    | 8351 |





Major patterns of residence and movement (Figure G1) show high residence in most areas, with greatest residence on the Scotian Shelf and in the western Gulf of Maine, substantial movement (from the Bay of Fundy to eastern Gulf of Maine, from the Scotian Shelf to Georges Bank, and from southern New England to the Great South Channel), and mixing within Georges Bank (recaptures on the northeast peak of Georges Bank, 551, from all Georges Bank release areas) and within the Mid-Atlantic Bight.

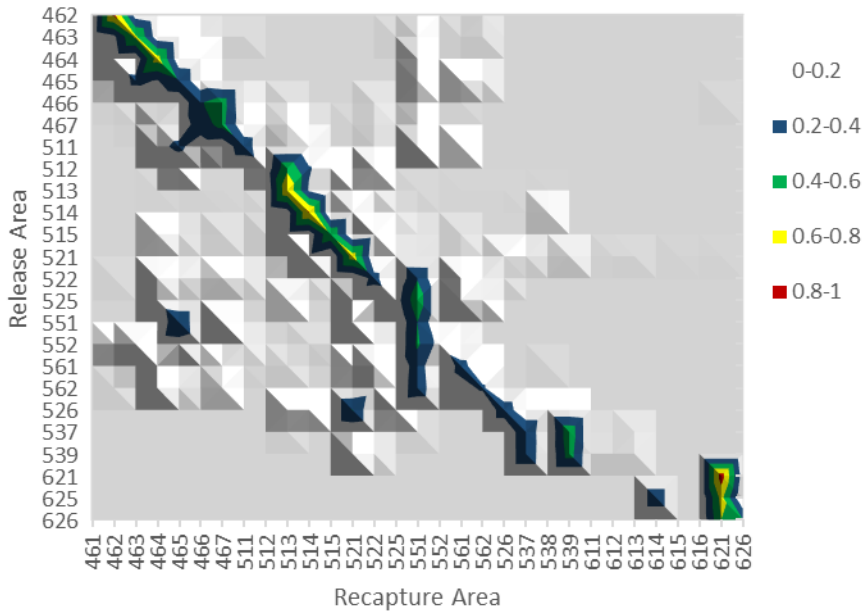


Figure G1. All tag recaptures from the Northeast Regional Cod Tagging Program, Canada DFO, MFI and MA SCCZ by statistical area of release and recapture, expressed as the proportion of known-area recaptures from each release area.

Western Gulf of Maine winter spawners (NRCTP + MFI) demonstrated strong spawning site fidelity (Table G2). Nearly all (99%) of recaptures during the same release season (95 with reported recapture location) were recaptured in the spawning area (513-514, western Gulf of Maine). Of the 290 recaptures with known recapture position in the post-spawning period, 93% were in the spawning area, and 6% moved to the Great South Channel (521), Georges Bank (522, 562) and southern New England (537, 538). In subsequent spawning seasons there was 93% residence in the Gulf of Maine, 92% residence in spawning area, and 2% movement to central Gulf of Maine (515), and 6% movement to the Great South Channel and Georges Bank.

Table G2. Recaptures from combined tagging studies (Tallack 2011, Loehrke 2014) of cod tagged during the winter spawning season (October-January) in the western Gulf of Maine (513-514) and recaptured during the same spawning season, the post-spawning season (February-September) and subsequent spawning seasons. Colors indicate relative proportions and outlines indicate residence in area of release.

| Season of Release                  |     | Recapture Area (# recaptures) |     |     |     |     |     |     |     |    |     | (proportion by area) |      |      |      |      |      |      |      |      |  |
|------------------------------------|-----|-------------------------------|-----|-----|-----|-----|-----|-----|-----|----|-----|----------------------|------|------|------|------|------|------|------|------|--|
| Rel.                               | 464 | 513                           | 514 | 515 | 521 | 522 | 562 | 537 | 538 | ?  | Sum | 464                  | 513  | 514  | 515  | 521  | 522  | 537  | 538  | 562  |  |
| 513                                | 0   | 28                            | 11  | 0   | 0   | 0   | 0   | 0   | 0   | 2  | 41  | 0                    | 0.72 | 0.28 | 0    | 0    | 0    | 0    | 0    | 0    |  |
| 514                                | 0   | 0                             | 55  | 1   | 0   | 0   | 0   | 0   | 0   | 2  | 58  | 0                    | 0    | 0.98 | 0.02 | 0    | 0    | 0    | 0    | 0    |  |
| Sum                                | 0   | 28                            | 66  | 1   | 0   | 0   | 0   | 0   | 0   | 4  | 99  |                      |      |      |      |      |      |      |      |      |  |
| <b>Post-Spawning Season</b>        |     |                               |     |     |     |     |     |     |     |    |     |                      |      |      |      |      |      |      |      |      |  |
| 513                                | 1   | 114                           | 27  | 2   | 4   | 3   | 1   | 0   | 0   | 10 | 162 | 0.01                 | 0.75 | 0.18 | 0.01 | 0.03 | 0.02 | 0.01 | 0    | 0    |  |
| 514                                | 0   | 7                             | 121 | 0   | 3   | 1   | 0   | 1   | 5   | 3  | 141 | 0                    | 0.05 | 0.88 | 0    | 0.02 | 0.01 | 0    | 0.01 | 0.04 |  |
| Sum                                | 1   | 121                           | 148 | 2   | 7   | 4   | 1   | 1   | 5   | 13 | 303 |                      |      |      |      |      |      |      |      |      |  |
| <b>Subsequent Spawning Seasons</b> |     |                               |     |     |     |     |     |     |     |    |     |                      |      |      |      |      |      |      |      |      |  |
| 513                                | 0   | 14                            | 5   | 1   | 0   | 0   | 0   | 0   | 0   | 2  | 22  | 0                    | 0.70 | 0.25 | 0.05 | 0    | 0    | 0    | 0    | 0    |  |
| 514                                | 0   | 2                             | 35  | 0   | 2   | 0   | 0   | 0   | 2   | 0  | 41  | 0                    | 0.05 | 0.85 | 0    | 0.05 | 0    | 0    | 0    | 0.05 |  |
| Sum                                | 0   | 16                            | 40  | 1   | 2   | 0   | 0   | 0   | 2   | 2  | 63  |                      |      |      |      |      |      |      |      |      |  |

Western Gulf of Maine spring spawners (NRCTP + MFI + MSCCZ) also demonstrated high spawning site fidelity (Table G3). Of the 1036 recaptures during the same release season with known recapture location, there was 97% residence in spawning area (513-514, western Gulf of Maine), and 2% movement to Great South Channel (521). There were 1138 recaptures with reported recapture location during the post-spawning season, with 91% residence in spawning area, 5% movement to the Great South Channel (521), 1% to central Gulf of Maine (515), 1% to Georges Bank (522, 525, 551, 561) and 2% to southern New England (526, 538). Similar to the results reported by Loehrke (2012) and Zemeckis et al. (2017), the 501 recaptured in subsequent spawning seasons with location information had 95% residence in spawning area, 1% movement central Gulf of Maine (515; 96% residence in the Gulf of Maine), 2% to Great South Channel (521), and 2% to Georges Bank (522, 525, 551, 561) and .

Table G3. Recaptures from combined studies (Tallack 2011, Loehrke 2014, Zemeckis et al. 2017) of cod tagged during the spring spawning season (April-July) in the western Gulf of Maine (513-514) and recaptured during the same spawning season, the post-spawning season (August-March) and subsequent spawning seasons. Colors indicate relative proportions and outlines indicate residence in area of release.

| <b>Season of Release</b>           |                                     |     |     |     |     |      |      |      |      |      |      |     |     |     |      |    |      |  |
|------------------------------------|-------------------------------------|-----|-----|-----|-----|------|------|------|------|------|------|-----|-----|-----|------|----|------|--|
|                                    | Recapture Area (# recaptures)       |     |     |     |     |      |      |      |      |      |      |     |     |     |      |    |      |  |
| Rel.                               | 464                                 | 465 | 466 | 467 | 512 | 513  | 514  | 515  | 521  | 522  | 525  | 551 | 561 | 526 | 538  | ?  | Sum  |  |
| 513                                | 0                                   | 0   | 0   | 0   | 0   | 462  | 22   | 0    | 2    | 1    | 0    | 1   | 0   | 0   | 0    | 18 | 506  |  |
| 514                                | 0                                   | 0   | 0   | 0   | 2   | 60   | 458  | 0    | 23   | 0    | 0    | 0   | 0   | 0   | 5    | 0  | 548  |  |
| Sum                                | 0                                   | 0   | 0   | 0   | 2   | 522  | 480  | 0    | 25   | 1    | 0    | 1   | 0   | 0   | 5    | 18 | 1054 |  |
| <b>Post-Spawning Season</b>        |                                     |     |     |     |     |      |      |      |      |      |      |     |     |     |      |    |      |  |
| 513                                | 2                                   | 1   | 1   | 1   | 0   | 405  | 205  | 10   | 20   | 5    | 0    | 1   | 0   | 1   | 1    | 85 | 738  |  |
| 514                                | 0                                   | 0   | 0   | 0   | 1   | 71   | 360  | 0    | 35   | 0    | 2    | 0   | 0   | 0   | 16   | 8  | 493  |  |
| Sum                                | 2                                   | 1   | 1   | 1   | 1   | 476  | 565  | 10   | 55   | 5    | 2    | 1   | 0   | 1   | 17   | 93 | 1231 |  |
| <b>Subsequent Spawning Seasons</b> |                                     |     |     |     |     |      |      |      |      |      |      |     |     |     |      |    |      |  |
| 513                                | 0                                   | 0   | 0   | 0   | 0   | 265  | 28   | 3    | 2    | 5    | 0    | 1   | 1   | 0   | 0    | 25 | 330  |  |
| 514                                | 0                                   | 0   | 0   | 0   | 0   | 21   | 162  | 1    | 9    | 0    | 1    | 0   | 0   | 0   | 2    | 2  | 198  |  |
| Sum                                | 0                                   | 0   | 0   | 0   | 0   | 286  | 190  | 4    | 11   | 5    | 1    | 1   | 1   | 0   | 2    | 27 | 528  |  |
| <b>Season of Release</b>           |                                     |     |     |     |     |      |      |      |      |      |      |     |     |     |      |    |      |  |
|                                    | Recapture Area (proportion by area) |     |     |     |     |      |      |      |      |      |      |     |     |     |      |    |      |  |
| Rel.                               | 464                                 | 465 | 466 | 467 | 512 | 513  | 514  | 515  | 521  | 522  | 525  | 551 | 561 | 526 | 538  |    |      |  |
| 513                                | 0                                   | 0   | 0   | 0   | 0   | 0.95 | 0.05 | 0    | 0    | 0    | 0    | 0   | 0   | 0   | 0    |    |      |  |
| 514                                | 0                                   | 0   | 0   | 0   | 0   | 0.11 | 0.84 | 0    | 0.04 | 0    | 0    | 0   | 0   | 0   | 0.01 |    |      |  |
| <b>Post-Spawning Season</b>        |                                     |     |     |     |     |      |      |      |      |      |      |     |     |     |      |    |      |  |
| 513                                | 0                                   | 0   | 0   | 0   | 0   | 0.62 | 0.31 | 0.02 | 0.03 | 0.01 | 0    | 0   | 0   | 0   | 0    |    |      |  |
| 514                                | 0                                   | 0   | 0   | 0   | 0   | 0.15 | 0.74 | 0    | 0.07 | 0    | 0    | 0   | 0   | 0   | 0.03 |    |      |  |
| <b>Subsequent Spawning Seasons</b> |                                     |     |     |     |     |      |      |      |      |      |      |     |     |     |      |    |      |  |
| 513                                | 0                                   | 0   | 0   | 0   | 0   | 0.87 | 0.09 | 0.01 | 0.01 | 0.02 | 0    | 0   | 0   | 0   | 0    |    |      |  |
| 514                                | 0                                   | 0   | 0   | 0   | 0   | 0.11 | 0.83 | 0.01 | 0.05 | 0    | 0.01 | 0   | 0   | 0   | 0.01 |    |      |  |

Georges Bank spawners (NRCTP + DFO 1994) demonstrated high spawning site fidelity and dispersal in the post-spawning season (Table G5). During the release season (183 recaptures with locations) there was 96% residence on Georges Bank (522, 525, 551, 552, 561, 562), 2% movement to the western Scotian Shelf and Browns Bank (464, 465), 1% movement to the western Gulf of Maine (513, 514), and 1% to the Great South Channel (521). During the post-spawning season (746 recaptures with locations), there was 70% residence on Georges Bank (522, 525, 551, 552, 561, 562), 26% movement to the Scotian Shelf-Bay of Fundy (461, 462, 463, 464, 465, 466, 467), 3% movement to the Great South Channel (521), and 2% movement to the Gulf of Maine (511, 512, 513, 514, 515). During subsequent spawning seasons (274 recaptures with locations), there was 72% residence on Georges Bank, 5% movement to the Scotian Shelf-Bay of Fundy (461, 462, 463, 464, 465, 466), 3% movement to the Great South Channel (521), 2% movement to the Gulf of Maine (511, 514), and 2% movement to Nantucket Shoals (526).

Table G5. Recaptures from combined tagging studies (Hunt et al. 1999, Tallack 2011) of cod tagged during the spawning season (December-May) on Georges Bank (522, 551, 552, 561, 562) and recaptured during the same spawning season, the post-spawning season (June-November) and subsequent spawning seasons. Colors indicate relative proportions and outlines indicate residence in area of release.

| Season of Release                   |      |      |      |      |      |      |      |      |      |      |      |      |      |      |      |      |      |      |      |      |    |     |    |
|-------------------------------------|------|------|------|------|------|------|------|------|------|------|------|------|------|------|------|------|------|------|------|------|----|-----|----|
| Recapture Area (# recaptures)       |      |      |      |      |      |      |      |      |      |      |      |      |      |      |      |      |      |      |      |      |    |     |    |
| Rel.                                | 461  | 462  | 463  | 464  | 465  | 466  | 467  | 511  | 512  | 513  | 514  | 515  | 521  | 522  | 525  | 551  | 552  | 561  | 562  | 526  | ?  | Sum |    |
| 522                                 | 0    | 0    | 0    | 0    | 0    | 0    | 0    | 0    | 0    | 0    | 0    | 0    | 1    | 18   | 2    | 0    | 0    | 1    | 0    | 0    | 0  | 1   | 23 |
| 552                                 | 0    | 0    | 0    | 2    | 0    | 0    | 0    | 0    | 0    | 0    | 1    | 0    | 1    | 0    | 0    | 1    | 0    | 1    | 0    | 0    | 0  | 4   | 10 |
| 561                                 | 0    | 0    | 0    | 0    | 1    | 0    | 0    | 0    | 0    | 1    | 0    | 0    | 0    | 5    | 5    | 0    | 0    | 112  | 20   | 0    | 10 | 154 |    |
| 562                                 | 0    | 0    | 0    | 0    | 0    | 0    | 0    | 0    | 0    | 0    | 0    | 0    | 0    | 0    | 3    | 0    | 0    | 0    | 8    | 0    | 0  | 11  |    |
| Sum                                 | 0    | 0    | 0    | 2    | 1    | 0    | 0    | 0    | 0    | 1    | 1    | 0    | 2    | 23   | 10   | 1    | 0    | 114  | 28   | 0    | 15 | 198 |    |
| Post-Spawning Season                |      |      |      |      |      |      |      |      |      |      |      |      |      |      |      |      |      |      |      |      |    |     |    |
| 522                                 | 0    | 1    | 0    | 34   | 4    | 2    | 7    | 3    | 0    | 1    | 1    | 0    | 3    | 32   | 0    | 100  | 0    | 3    | 5    | 0    | 15 | 211 |    |
| 551                                 | 0    | 0    | 0    | 0    | 3    | 0    | 1    | 0    | 0    | 0    | 0    | 0    | 1    | 0    | 0    | 4    | 0    | 0    | 0    | 0    | 1  | 10  |    |
| 552                                 | 3    | 8    | 19   | 8    | 14   | 4    | 0    | 2    | 0    | 0    | 0    | 1    | 0    | 2    | 0    | 74   | 23   | 1    | 0    | 0    | 32 | 191 |    |
| 561                                 | 0    | 1    | 5    | 37   | 7    | 2    | 9    | 0    | 1    | 3    | 0    | 0    | 14   | 28   | 1    | 139  | 0    | 3    | 5    | 0    | 15 | 270 |    |
| 562                                 | 0    | 1    | 0    | 15   | 3    | 1    | 6    | 0    | 0    | 0    | 0    | 0    | 1    | 9    | 0    | 58   | 5    | 14   | 14   | 0    | 11 | 138 |    |
| Sum                                 | 3    | 11   | 24   | 94   | 31   | 9    | 23   | 5    | 1    | 4    | 1    | 1    | 19   | 71   | 1    | 375  | 28   | 21   | 24   | 0    | 74 | 820 |    |
| Subsequent Spawning Seasons         |      |      |      |      |      |      |      |      |      |      |      |      |      |      |      |      |      |      |      |      |    |     |    |
| 522                                 | 0    | 0    | 0    | 1    | 0    | 0    | 0    | 0    | 0    | 0    | 1    | 0    | 4    | 21   | 3    | 6    | 0    | 12   | 6    | 2    | 9  | 65  |    |
| 551                                 | 0    | 0    | 0    | 0    | 1    | 0    | 0    | 0    | 0    | 0    | 0    | 0    | 0    | 0    | 0    | 2    | 0    | 0    | 0    | 0    | 1  | 4   |    |
| 552                                 | 3    | 8    | 17   | 7    | 12   | 4    | 0    | 2    | 0    | 0    | 0    | 0    | 0    | 0    | 0    | 42   | 8    | 1    | 0    | 0    | 25 | 129 |    |
| 561                                 | 0    | 0    | 1    | 3    | 0    | 0    | 0    | 2    | 0    | 0    | 0    | 0    | 4    | 28   | 5    | 3    | 0    | 5    | 2    | 0    | 12 | 65  |    |
| 562                                 | 0    | 0    | 0    | 3    | 0    | 0    | 0    | 0    | 0    | 0    | 0    | 0    | 1    | 7    | 3    | 10   | 1    | 10   | 23   | 0    | 15 | 73  |    |
| Sum                                 | 3    | 8    | 18   | 14   | 13   | 4    | 0    | 4    | 0    | 0    | 1    | 0    | 9    | 56   | 11   | 63   | 9    | 28   | 31   | 2    | 62 | 336 |    |
| Season of Release                   |      |      |      |      |      |      |      |      |      |      |      |      |      |      |      |      |      |      |      |      |    |     |    |
| Recapture Area (proportion by area) |      |      |      |      |      |      |      |      |      |      |      |      |      |      |      |      |      |      |      |      |    |     |    |
| Rel.                                | 461  | 462  | 463  | 464  | 465  | 466  | 467  | 511  | 512  | 513  | 514  | 515  | 521  | 522  | 525  | 551  | 552  | 561  | 562  | 526  |    |     |    |
| 522                                 | 0    | 0    | 0    | 0    | 0    | 0    | 0    | 0    | 0    | 0    | 0    | 0    | 0.05 | 0.82 | 0.09 | 0    | 0    | 0.05 | 0    | 0    |    |     |    |
| 552                                 | 0    | 0    | 0    | 0.33 | 0    | 0    | 0    | 0    | 0    | 0    | 0.17 | 0    | 0.17 | 0    | 0    | 0.17 | 0    | 0.17 | 0    | 0    |    |     |    |
| 561                                 | 0    | 0    | 0    | 0    | 0.01 | 0    | 0    | 0    | 0    | 0.01 | 0    | 0    | 0    | 0.03 | 0.03 | 0    | 0    | 0.78 | 0.14 | 0    |    |     |    |
| 562                                 | 0    | 0    | 0    | 0    | 0    | 0    | 0    | 0    | 0    | 0    | 0    | 0    | 0    | 0.27 | 0    | 0    | 0    | 0    | 0.73 | 0    |    |     |    |
| Post-Spawning Season                |      |      |      |      |      |      |      |      |      |      |      |      |      |      |      |      |      |      |      |      |    |     |    |
| 522                                 | 0    | 0.01 | 0    | 0.17 | 0.02 | 0.01 | 0.04 | 0.02 | 0    | 0.01 | 0.01 | 0    | 0.02 | 0.16 | 0    | 0.51 | 0    | 0.02 | 0.03 | 0    |    |     |    |
| 551                                 | 0    | 0    | 0    | 0    | 0.33 | 0    | 0.11 | 0    | 0    | 0    | 0    | 0    | 0.11 | 0    | 0    | 0.44 | 0    | 0    | 0    | 0    |    |     |    |
| 552                                 | 0.02 | 0.05 | 0.12 | 0.05 | 0.09 | 0.03 | 0    | 0.01 | 0    | 0    | 0    | 0.01 | 0    | 0.01 | 0    | 0.47 | 0.14 | 0.01 | 0    | 0    |    |     |    |
| 561                                 | 0    | 0.00 | 0.02 | 0.15 | 0.03 | 0.01 | 0.04 | 0    | 0.00 | 0.01 | 0    | 0    | 0.05 | 0.11 | 0.00 | 0.55 | 0    | 0.01 | 0.02 | 0    |    |     |    |
| 562                                 | 0    | 0.01 | 0    | 0.12 | 0.02 | 0.01 | 0.05 | 0    | 0    | 0    | 0    | 0    | 0.01 | 0.07 | 0    | 0.46 | 0.04 | 0.11 | 0.11 | 0    |    |     |    |
| Subsequent Spawning Seasons         |      |      |      |      |      |      |      |      |      |      |      |      |      |      |      |      |      |      |      |      |    |     |    |
| 522                                 | 0    | 0    | 0    | 0.02 | 0    | 0    | 0    | 0    | 0    | 0    | 0.02 | 0    | 0.07 | 0.38 | 0.05 | 0.11 | 0    | 0.21 | 0.11 | 0.04 |    |     |    |
| 551                                 | 0    | 0    | 0    | 0    | 0.33 | 0    | 0    | 0    | 0    | 0    | 0    | 0    | 0    | 0    | 0    | 0.67 | 0    | 0    | 0    | 0    |    |     |    |
| 552                                 | 0.03 | 0.08 | 0.16 | 0.07 | 0.12 | 0.04 | 0.00 | 0.02 | 0    | 0    | 0    | 0    | 0    | 0    | 0    | 0.40 | 0.08 | 0.01 | 0    | 0    |    |     |    |
| 561                                 | 0    | 0    | 0.02 | 0.06 | 0    | 0    | 0    | 0.04 | 0    | 0    | 0    | 0    | 0.08 | 0.53 | 0.09 | 0.06 | 0    | 0.09 | 0.04 | 0    |    |     |    |
| 562                                 | 0    | 0    | 0    | 0.05 | 0    | 0    | 0    | 0    | 0    | 0    | 0    | 0    | 0.02 | 0.12 | 0.05 | 0.17 | 0.02 | 0.17 | 0.40 | 0    |    |     |    |

Western Scotian Shelf-Bay of Fundy spawners (NRCTP + DFO 2001-2004) demonstrated high spawning site fidelity (Table G6). There was 100% residence in the spawning area (463, 464, 465, 466, 467) during the release season (146 recaptures with locations), as well as 100% residence in the Bay of Fundy (466, 467). During the post-spawning season (503 recaptures with locations), there was 94% residence in the spawning area, 4% movement to Georges Bank (522, 551) and 2% movement to the Gulf of Maine (511, 513). During subsequent spawning seasons (168 recaptures with locations), there was 92% residence in the spawning area, 5% to Georges Bank (522, 551, 561), 3% movement to the Gulf of Maine (511, 513), and 1% to Mid Atlantic (621, off DE-MD).

Table G6. Recaptures from combined tagging studies (Clark and Emberley 2008, Tallack 2011) of cod tagged during the spawning season (January-May) in the Bay of Fundy (466-467) and recaptured during the same spawning season, the post-spawning season (June-December) and subsequent spawning seasons. Colors indicate relative proportions and outlines indicate residence in area of release.

| Season of Release                  |      |      |      |      |      |      |      |      |      |      |      |      |      |      |    |     |     |
|------------------------------------|------|------|------|------|------|------|------|------|------|------|------|------|------|------|----|-----|-----|
| Recapture Area (# recaptures)      |      |      |      |      |      |      |      |      |      |      |      |      |      |      |    |     |     |
| Rel.                               | 461  | 462  | 463  | 464  | 465  | 466  | 467  | 511  | 513  | 522  | 551  | 561  | 562  | 621  | ?  | Sum |     |
| 463                                |      |      | 8    |      | 1    |      |      |      |      |      |      |      |      |      |    | 0   | 9   |
| 465                                |      |      | 3    |      | 6    | 1    |      |      |      |      |      |      |      |      |    | 0   | 10  |
| 466                                |      |      |      |      |      | 44   | 16   |      |      |      |      |      |      |      |    |     | 60  |
| 467                                |      |      |      |      |      | 32   | 34   |      |      |      |      |      |      |      |    | 1   | 67  |
| Sum                                |      | 0    | 0    | 0    | 0    | 76   | 50   | 0    | 0    | 0    | 0    | 0    | 0    | 0    | 1  | 127 |     |
| <b>Post-Spawning Season</b>        |      |      |      |      |      |      |      |      |      |      |      |      |      |      |    |     |     |
| 463                                | 3    | 1    | 41   | 5    | 3    | 1    |      |      |      |      |      | 1    |      |      |    | 3   | 58  |
| 464                                | 1    |      |      | 4    | 1    |      |      |      |      |      |      |      |      |      |    | 2   | 8   |
| 465                                |      | 1    | 14   | 5    | 10   | 2    |      |      |      |      |      | 3    |      | 1    |    | 3   | 39  |
| 466                                |      |      |      |      | 8    | 97   | 179  | 5    | 2    | 3    | 9    |      |      |      |    | 12  | 315 |
| 467                                |      |      | 1    | 5    | 3    | 60   | 119  | 5    | 1    | 1    | 5    |      |      |      |    | 5   | 205 |
| Sum                                |      | 0    | 1    | 5    | 11   | 157  | 298  | 10   | 3    | 4    | 14   | 0    |      | 0    | 17 | 520 |     |
| <b>Subsequent Spawning Seasons</b> |      |      |      |      |      |      |      |      |      |      |      |      |      |      |    |     |     |
| 463                                |      | 1    | 3    | 5    |      |      |      |      |      |      |      |      | 1    |      |    | 0   | 10  |
| 464                                |      | 1    |      | 1    |      |      |      |      |      |      |      |      |      |      |    | 0   | 2   |
| 465                                |      | 1    | 1    | 6    | 6    | 1    |      |      |      |      |      | 1    | 3    |      |    | 0   | 19  |
| 466                                |      | 1    |      | 9    | 11   | 31   | 29   | 1    | 1    | 1    |      | 1    |      | 1    |    | 4   | 90  |
| 467                                |      |      |      | 6    | 10   | 14   | 9    | 1    | 1    |      | 1    |      |      |      |    | 5   | 47  |
| Sum                                |      | 1    | 0    | 15   | 21   | 45   | 38   | 2    | 2    | 1    | 1    | 1    |      | 1    | 9  | 137 |     |
| <b>Season of Release</b>           |      |      |      |      |      |      |      |      |      |      |      |      |      |      |    |     |     |
| Recapture Area (# recaptures)      |      |      |      |      |      |      |      |      |      |      |      |      |      |      |    |     |     |
| Rel.                               | 461  | 462  | 463  | 464  | 465  | 466  | 467  | 511  | 513  | 522  | 551  | 561  | 562  | 621  |    |     |     |
| 463                                | 0    | 0    | 0.89 | 0    | 0.11 | 0    | 0    | 0    | 0    | 0    | 0    | 0    | 0    | 0    |    |     |     |
| 465                                | 0    | 0    | 0.3  | 0    | 0.6  | 0.1  | 0    | 0    | 0    | 0    | 0    | 0    | 0    | 0    |    |     |     |
| 466                                | 0    | 0    | 0    | 0    | 0    | 0.73 | 0.27 | 0    | 0    | 0    | 0    | 0    | 0    | 0    |    |     |     |
| 467                                | 0    | 0    | 0    | 0    | 0    | 0.48 | 0.52 | 0    | 0    | 0    | 0    | 0    | 0    | 0    |    |     |     |
| <b>Post-Spawning Season</b>        |      |      |      |      |      |      |      |      |      |      |      |      |      |      |    |     |     |
| 463                                | 0.05 | 0.02 | 0.75 | 0.09 | 0.05 | 0.02 | 0    | 0    | 0    | 0    | 0.02 | 0    | 0    | 0    |    |     |     |
| 464                                | 0.17 | 0    | 0    | 0.67 | 0.17 | 0    | 0    | 0    | 0    | 0    | 0    | 0    | 0    | 0    |    |     |     |
| 465                                | 0    | 0.03 | 0.39 | 0.14 | 0.28 | 0.06 | 0    | 0    | 0    | 0    | 0.08 | 0    | 0.03 | 0    |    |     |     |
| 466                                | 0    | 0    | 0    | 0    | 0.03 | 0.32 | 0.59 | 0.02 | 0.01 | 0.01 | 0.03 | 0    | 0    | 0    |    |     |     |
| 467                                | 0    | 0    | 0.01 | 0.03 | 0.02 | 0.3  | 0.6  | 0.03 | 0.01 | 0.01 | 0.03 | 0    | 0    | 0    |    |     |     |
| <b>Subsequent Spawning Seasons</b> |      |      |      |      |      |      |      |      |      |      |      |      |      |      |    |     |     |
| 463                                | 0    | 0.1  | 0.3  | 0.5  | 0    | 0    | 0    | 0    | 0    | 0    | 0    | 0.1  | 0    | 0    |    |     |     |
| 464                                | 0    | 0.5  | 0    | 0.5  | 0    | 0    | 0    | 0    | 0    | 0    | 0    | 0    | 0    | 0    |    |     |     |
| 465                                | 0    | 0.05 | 0.05 | 0.32 | 0.32 | 0.05 | 0    | 0    | 0    | 0    | 0.05 | 0.16 | 0    | 0    |    |     |     |
| 466                                | 0    | 0.01 | 0    | 0.1  | 0.13 | 0.36 | 0.34 | 0.01 | 0.01 | 0.01 | 0    | 0.01 | 0    | 0.01 |    |     |     |
| 467                                | 0    | 0    | 0    | 0.14 | 0.24 | 0.33 | 0.21 | 0.02 | 0.02 | 0    | 0.02 | 0    | 0    | 0    |    |     |     |

# CHAPTER 7. FISHERMEN'S ECOLOGICAL KNOWLEDGE

Gregory DeCelles and Ted Ames

## Abstract

Fishermen's Ecological Knowledge (FEK) related to the spawning behavior and population structure of cod in U.S. waters was collected and synthesized through semi-structured interviews. Fifty fishermen, with homeports ranging from New York to Nova Scotia were interviewed as part of this project. Collectively, these fishermen had 2,000 years of experience targeting groundfish, including 1,700 years of directed fishing experience for cod in the Gulf of Maine and on Georges Bank. The fishermen had a detailed understanding of cod movement patterns, which spanned a range of spatial and temporal scales. The fishermen also had fine-scale knowledge of the spatial and temporal distribution of spawning activity, and their knowledge was used to produce a detailed map of cod spawning grounds on Georges Bank, Nantucket Shoals, the Great South Channel, and the western Gulf of Maine. The fishermen observed that spawning on western Georges Bank (Nantucket Shoals and Great South Channel) peaks in November and December, while spawning activity across eastern Georges Bank primarily occurs from January through April. Many of the fishermen perceived that cod on eastern and western Georges Bank are likely distinct groups, as noted through differences in fish size, diet, fillet quality, geographic distribution, and seasonal movements. Fishermen also remarked that cod on western Georges Bank are connected to groups in the western Gulf of Maine. The information collected through this study reaffirms that FEK is a valuable supplement to traditional scientific information, and that FEK can help inform multidisciplinary stock identification studies.

## Introduction

Fishermen's Ecological Knowledge (FEK) can be defined as the experiential knowledge that fishermen accumulate as they interact with the marine environment over an extended period of time (Hind 2015). Fishermen share information in real time while at sea, and also acquire knowledge from their predecessors, allowing them to accumulate a knowledge base that spans a range of temporal and spatial scales (Johannes et al. 2000; Bergmann et al. 2004). For example, fishermen often understand how fish move seasonally across large geographic areas for feeding or spawning. At the same time, fishermen also recognize that abundance and distribution of fish can vary at fine spatial scales, and are aware of fine-scale habitat features (e.g., habitat edges, boulder piles, etc...) that influence fish distribution. Following years of observation, fishermen are cognizant of long-term trends in fish abundance and changes in size structure (Pederson and Hall Arber 1999; Macdonald et al. 2014). In addition, fishermen also understand how the distribution and abundance of target species can change across tidal, diel, lunar, and seasonal scales (Berkes et al. 2000; Johannes et al. 2000).

There is increasing recognition that FEK can serve as a valuable supplement to information collected using traditional scientific approaches (Murray et al. 2008a; Hind 2015), and that FEK should routinely be considered as part of the best available information



(Stephenson et al. 2016). Combining FEK with scientific data allows for a deeper understanding of biological and ecological issues that are important for sustainable management (Hedeholm et al. 2016). Further, the solicitation of FEK provides an avenue for fishermen to actively contribute to the scientific information that informs resource management (MacDonald et al. 2014; Yates 2014), which can lead to increased credibility and trust in subsequent management actions (Bergmann et al. 2004; Stephenson et al. 2016).

The scientific literature abounds with case studies where FEK has been used to better understand the life history of commercially important fish stocks. For example, FEK has been used throughout the world to identify the timing and location of spawning activity (e.g., Neis 1999a; Johannes et al. 2000; Silvano et al. 2006), and fishermen often identified spawning locations that had not been previously detected using traditional scientific approaches (e.g., Neis 1998; Maurstad 2002). Additionally, FEK has been used to document the extirpation of spawning components, which provides critical insights into long term changes in productivity, recruitment, and population structure (Neis 1998; Pederson and Hall-Arber 1999; Ames 2004).

Because cod is an important target species throughout much of its range, FEK has proven to be a valuable source of information to better understand the life history and behavior of cod populations. In New England, historical research (e.g., Goode 1887; Rich 1929; Bigelow and Schroeder 1953) related to the seasonal movements, habitat preferences, and diets of cod relied extensively on information provided by fishermen. In Newfoundland FEK has been collected and analyzed in conjunction with scientific information to provide a more holistic understanding of the spawning dynamics and stock structure of cod, and fishermen could readily differentiate between cod from different groups by their body shape, color, filet quality, diet, and behavior (Neis 1998; Neis et al. 1999a,b; Murray et al. 2008a). Maurstad (2002) solicited FEK to document cod spawning grounds off the coast of Norway, including many locations that were previously unknown to scientists. Figus et al. (2017) used questionnaires and semi-structured interviews to collect FEK related to long-term changes in the abundance, distribution, and condition of cod in the Baltic Sea.

The overarching goal of this chapter was to collect and synthesize FEK related to the stock structure and spawning behavior of Atlantic cod in U.S. waters. This report builds off the previous work of DeCelles et al. (2017) which collected and synthesized FEK related to cod spawning on Georges Bank. The specific research objectives of this chapter were as follows:

- 1) Collect FEK to better understand the spatial and temporal distribution of cod spawning activity in the western Gulf of Maine.
- 2) Gather FEK related to morphometric variation amongst cod spawning groups.
- 3) Collect FEK related to connectivity amongst cod spawning components.
- 4) Synthesize the FEK collected during objectives 1-3, to serve as a complement to our traditional scientific knowledge to inform cod stock structure in the region.

Interested readers are encouraged to refer to the previous research of Ames (1998, 2004) and DeCelles et al. (2017) who used FEK to investigate the spawning grounds and stock structure of cod in the eastern Gulf of Maine, and on Georges Bank, respectively.

## Methods & Materials

### *Georges Bank and Western Gulf of Maine*

Semi-structured interviews were completed with active and retired commercial fishermen who have experience fishing for cod in the Gulf of Maine and on Georges Bank. Fifty fishermen were interviewed in total. Forty interviews were conducted as part of the DeCelles et al. (2017) study, and the geographic focus of those interviews was Georges Bank, the Great South Channel, and Nantucket Shoals. An additional ten fishermen were interviewed in 2018 to collect FEK related to Atlantic cod in the western Gulf of Maine. Each interview began with a series of demographic questions designed to document the fishermen's experience fishing for groundfish, and their experience specifically targeting cod on Georges Bank or in the Gulf of Maine (Section 1 of Table 7.1). Fishermen were also asked to identify times and locations where they had captured spawning cod, and a common series of questions was asked related to each spawning ground identified by the fishermen (Section 2 of Table 7.1). NOAA nautical charts, which are familiar to the fishermen, were used to help identify and delineate the spawning grounds. Many fishermen also voluntarily provided spatial information from their own logbooks, paper charts, and electronic plotters. We asked the fishermen to specifically indicate the criteria they used to classify an area as a cod spawning ground. U.S. fishermen typically dress their catch at sea, giving them a chance to examine the stomach contents and maturity stage of their catch. When fishermen indicated that they were basing their reports on observed cod maturity stages, a photo guide provided by Dr. Richard McBride (NOAA/NEFSC) was shown to them in an attempt to identify specific maturity stages that they remembered seeing in the catch. The visual guide often helped to delineate spawning grounds from feeding grounds. The final part of the interview (Section 3 of Table 7.1) included questions related to the stock structure of cod in the region.

The spawning grounds identified by each fisherman were digitally mapped using ArcGIS, and a unique shapefile was produced for each spawning ground. Monthly maps were created by grouping all of the spawning grounds that were identified to be active in each month. For the spawning grounds identified on Georges Bank and Nantucket Shoals, ArcGIS geoprocessing tools were used to quantify the spatial overlap amongst spawning grounds (shapefiles) in order to quantify the number of fishermen that independently identified spawning activity at a given location. Spawning grounds that were independently identified by three or more fishermen were classified as "consensus spawning grounds".

**Table 7.1. List of questions that were asked during the semi-structured interviews.**

| <b>Part 1: Demographic Questions</b>  |
|---|
| 1) How old are you?   |
| 2) How many total years of experience do you have commercial fishing?   |
| 3) How many years of experience do you have commercial fishing for groundfish in the Gulf of Maine?   |
| 4) How many years of experience do you have fishing <u>specifically for cod</u> in the Gulf of Maine?   |
| 5) Of the total years you have spent fishing for groundfish in the Gulf of Maine, how many years were you a deckhand, a mate, and a captain?  |
| 6) What types of gear did you use when fishing for cod?   |
| <b>Part 2: Questions Specific To Each Spawning Ground</b>   |
| 1) What was the name of the spawning ground?  |
| 2) What months did spawning occur here?   |
| 3) How were you able to determine this area was a cod spawning ground?  |
| 4) What maturity stages did you see at this spawning ground?  |
| 5) At what depths did you find spawning cod at this location?   |
| 6) How would you describe the magnitude of cod spawning at this site?   |
| 7) What was the predictability or consistency of this spawning ground from year to year?  |
| 8) What size were the majority of cod you encountered at this spawning ground?  |
| 9) How would you describe the habitat at this spawning ground?  |
| 10) Is this spawning ground still active?   |
| 10a) If the spawning ground is still active, what is the magnitude of spawning now, compared to past levels?                                  |
| 10b) If the spawning ground is no longer active, what year did it cease to be active, and why do you think spawning stopped at this location? |
| <b>Part 3: Secondary Questions That Were Asked As Time Allowed</b>  |
| 1) Is there connectivity between the spawning sites you identified?   |
| 2) Was there anything unique about the shape of the cod at any of the spawning grounds?   |
| 3) Was there anything unique about the color of the cod at any of the spawning grounds?   |
| 4) Is there anything else that you think is important for us to know?   |

## *Eastern Gulf of Maine*

Fishermen's Ecological Knowledge for the eastern Gulf of Maine was collected from interviews with 27 retired high-liner fishermen known locally for their expertise in catching cod and haddock. For a detailed description of the methods please refer to Ames (1998). The historical spawning grounds were later used as fixed points of origin, linking historical spawning areas with the seasonal movement patterns of cod, based on interviews of fishermen during the 1920s (Rich, 1929). This provided insights into the population structure of cod from Ipswich Bay to the Lurcher Shoal in Western Nova Scotia, which is detailed in Ames (2004). Cod from the Midcoast Subpopulation formerly occupied grounds in NAFO Management Area 511, while cod in the Eastern Subpopulation occupied Management Area 512.

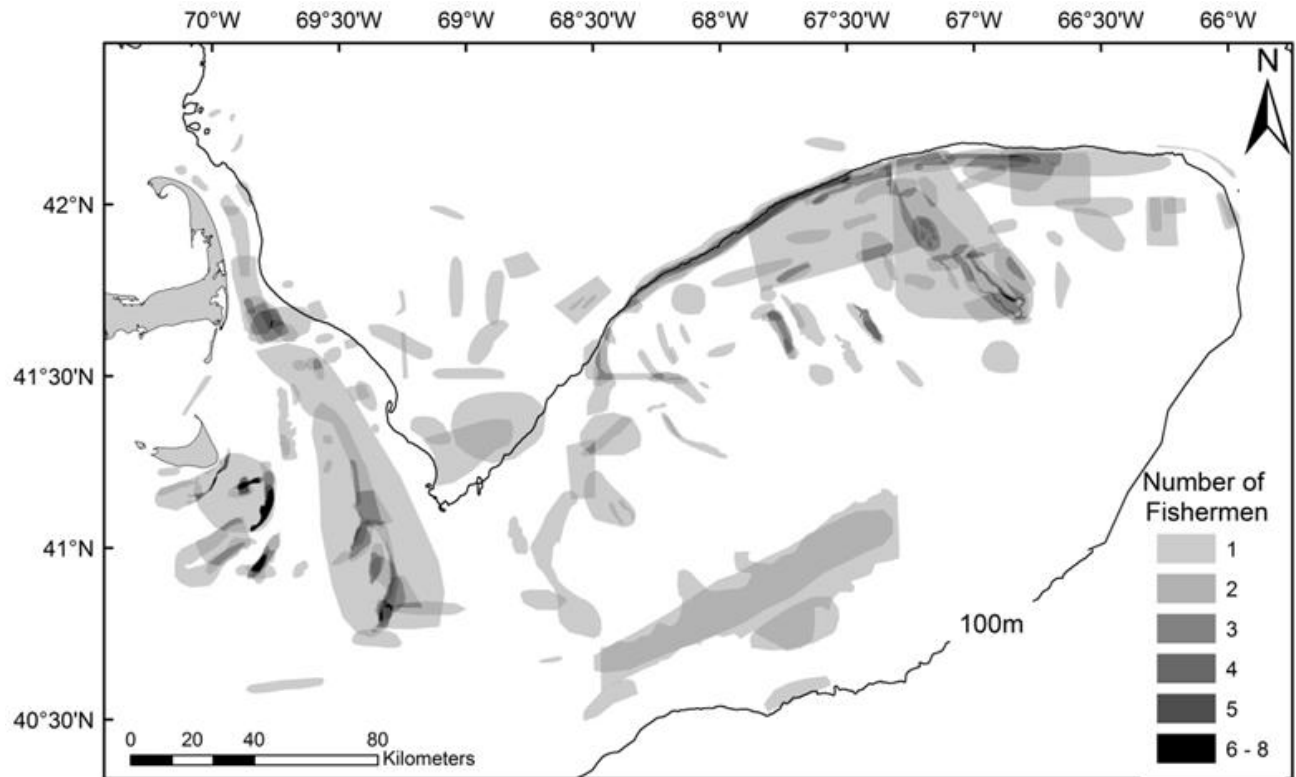
## Results

### *Temporal and Spatial Distribution of Cod Spawning – Georges Bank and Western Gulf of Maine*

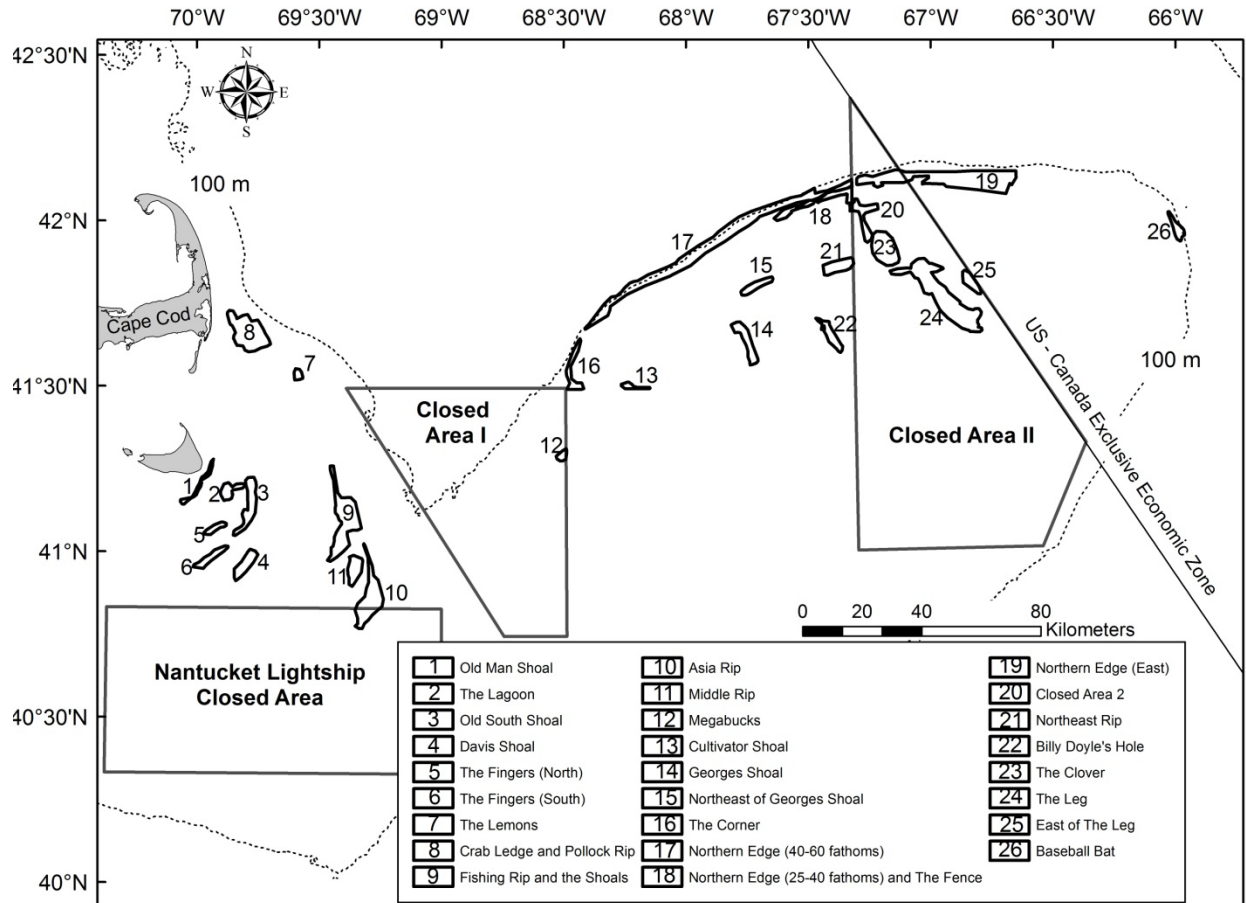
Fifty fishermen were interviewed in total, and collectively these individuals had 2,000 years of fishing experience, including 1,700 years of experience specifically targeting cod on Georges Bank and in the Gulf of Maine. With the exception of one individual, all of the fishermen had been captains for the majority of their careers. At the time of the interviews, the captains had an average of 34.7 years of experience targeting cod on Georges Bank and/or the Gulf of Maine (range = 12 to 66 years). The majority of fishermen (n = 45) used an otter trawl to target cod, while others used gillnets (n = 10), longline (n = 8), and rod and reel (n = 4). Some fishermen used multiple gear types during their careers. The captains we interviewed fished from New Bedford, MA (n = 21), Chatham, MA (n = 7), Hyannis, MA (n = 1), Gloucester, MA (n = 6), Newburyport, MA (n = 1), Nantucket, MA (n = 1), Scituate, MA (n = 1), Boston, MA (n = 2), Montauk, NY (n = 1), Hampton, NH (n = 2), Portland, ME (n = 1), Pubnico, Nova Scotia (n = 3), Yarmouth, Nova Scotia (n = 2), and Lunenburg, Nova Scotia (n = 1).

It was evident during the interviews that captains were attentive to the reproductive condition of the cod they had caught. American fishermen would observe the reproductive condition of the fish when they gutted them, and often observed large amounts of milt or eggs on the deck when they encountered spawning cod. However, Canadian fishermen do not dress their fish at sea, and instead land them round. Therefore, Canadian fishermen typically could not tell that they caught spawning cod unless they observed milt or eggs freely flowing from the fish. Other factors fishermen described were high catch rates associated with targeting spawning aggregations, and some noted they could identify cod spawning aggregations based on the images appearing on their sounders.

During the DeCelles et al (2017) study, the 40 fishermen that were interviewed identified 210 cod spawning grounds in total on Nantucket shoals and Georges Bank, although the same spawning grounds were often identified independently by multiple fishermen (Figure 7.1). Twenty six consensus spawning grounds were documented during the interviews, (Figure 7.2), many of which were discrete and associated with specific bathymetric features such as channels between shoals, edge habitats adjacent to shoals, complex rocky bottom, or areas with steep bathymetric contours.

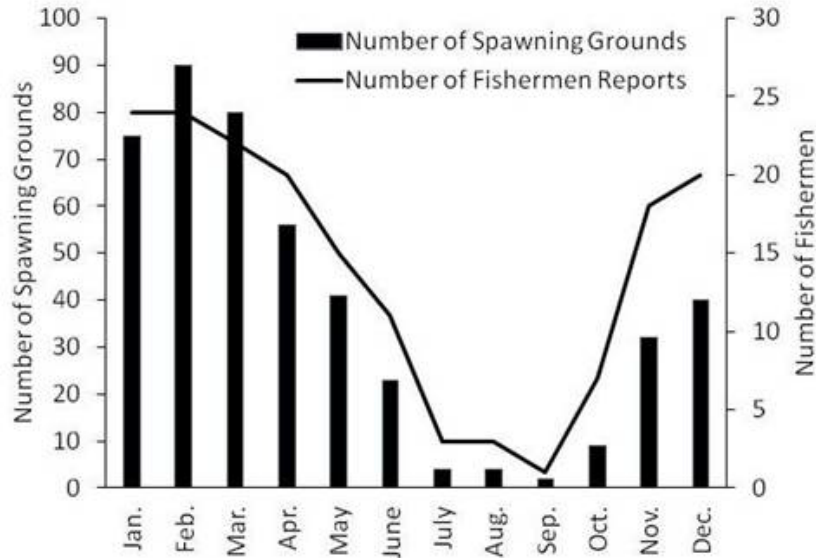


**Figure 7.1. Cod spawning grounds on Nantucket Shoals and Georges Bank that were identified by fishermen during the DeCelles et al (2017) study (n=210). Each polygon represents a spawning ground that was identified by a single fisherman. The shading is used to identify areas where cod spawning activity was independently identified by multiple fishermen.**



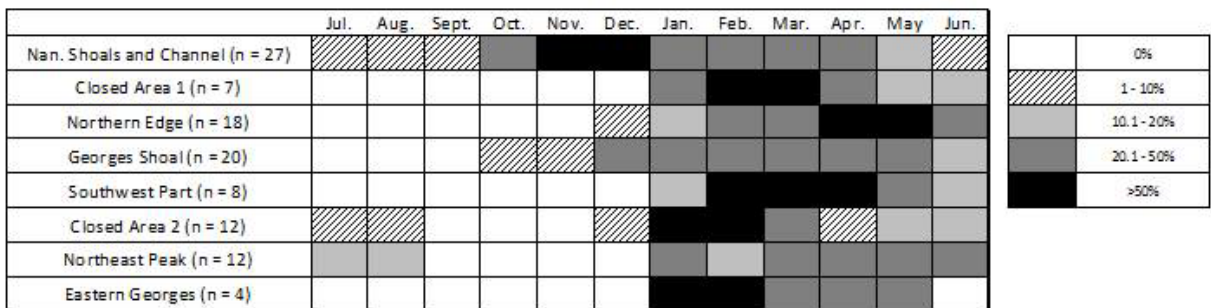
**Figure 7.2. Consensus spawning grounds on Georges Bank and Nantucket Shoals that were identified independently by at least three fishermen during the DeCelles et al (2017) study.**

The forty fishermen interviewed during the DeCelles et al. (2017) study had detailed knowledge about the timing of cod spawning across Georges Bank, and the seasonal availability of cod on the fishing grounds. Fishermen reported that there is cod spawning is relatively rare on Georges Bank between July and September, and that cod spawning activity increases from October to December (Figure 7.3). Over half of the participating fishermen reported that cod spawning locations that were active in January, February, and March. Fishermen noted that cod spawning activity declined from relatively high levels in April to lesser amounts in May and June.



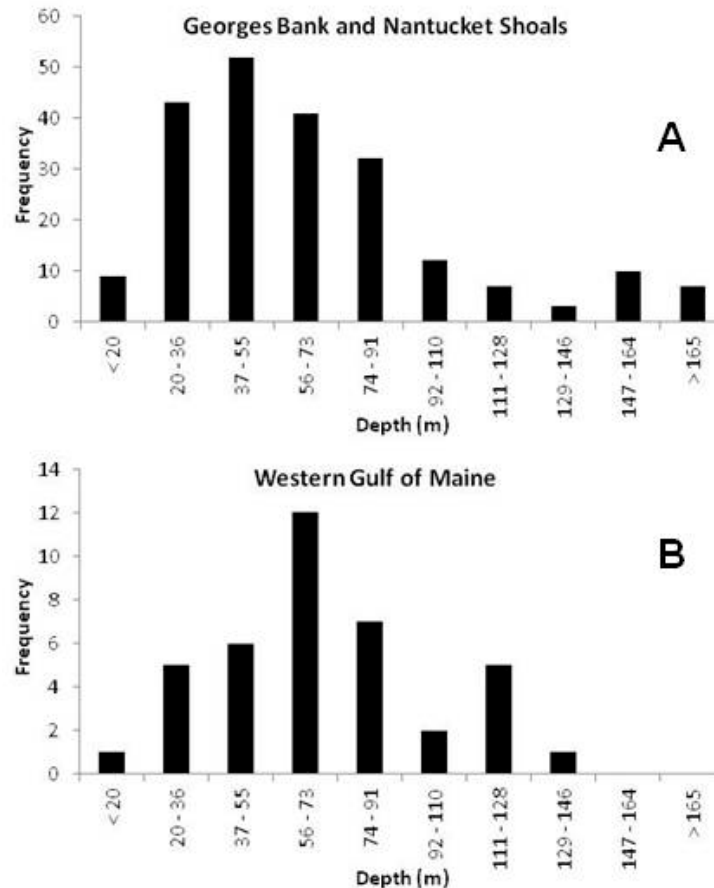
**Figure 7.3. The number of Atlantic cod spawning grounds, and the number of fishermen that identified spawning activity in each month on Georges Bank and Nantucket Shoals. Figure taken from DeCelles et al. 2017.**

Fishermen reported that the timing of spawning activity varied across the different regions of Georges Bank. Most fishermen described the spawning period on western Georges Bank (Nantucket Shoals and the Great South Channel) as occurring from October to April, with peak spawning in November and December, although at least one fisherman described spawning activity in the region in each month (Figure 7.4). Based on fishermen’s reports, it appears that peak spawning occurs earlier on Nantucket Shoals and the Great South Channel than elsewhere on Georges Bank. On Georges Shoal, the spawning season was described as lasting from October through June, with the majority of spawning observed between December and May. Peak spawning in the relatively deep waters of the Northern Flank was reported in April and May.



**Figure 7.4. Proportion of fishermen that reported Atlantic cod spawning activity in a given month for each of the eight regions of Georges Bank. The number of fishermen that identified spawning is shown in parenthesis. Figure taken from DeCelles et al. 2017.**

Fishermen reported that cod spawning occurs across a wide range of depths on Georges Bank and Nantucket Shoals (Figure 7.5A). Although the majority of spawning activity was reported to occur in depths ranging from 20 to 91 meters, fishermen also reported that cod also spawn in shallow water on Nantucket Shoals ( $\leq 20$ m) and in relatively deep water ( $\geq 165$ m) off the Northern Edge of Georges Bank.



**Figure 7.5. The depth ranges of the Atlantic cod spawning grounds that were reported by fishermen on Georges Bank and Nantucket Shoals (A), and in the western Gulf of Maine (B).**

Fishermen typically identified one or more habitat characteristics associated with each cod spawning ground, and these habitat characteristics included both abiotic and biotic attributes. On Georges Bank, cod spawning grounds were most commonly characterized as occurring in areas with sandy substrates, and fishermen often described sand “lumps” as the preferred spawning habitat, particularly the spawning grounds identified on Nantucket Shoals and Georges Shoals (Table 7.2). The fishermen also reported that the cod spawning grounds on Nantucket Shoals and Georges Shoals often contained high concentrations of shellfish, including surf clams, quahogs, and mussels. Rocky, hard bottom habitats and areas with gravel substrate were also identified as important for cod spawning activity, and were the most common habitat type associated with cod spawning activity in the Gulf of Maine. The fishermen often observed that

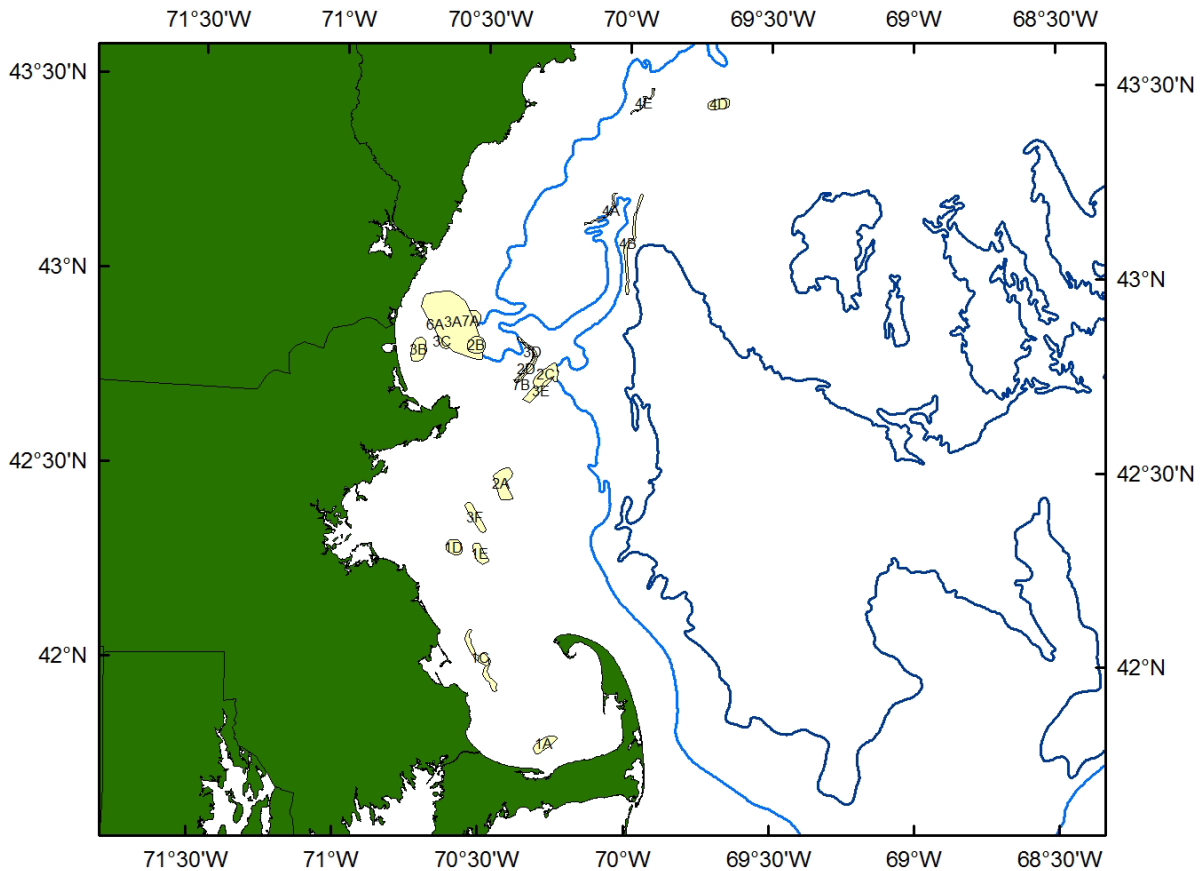


cod spawning grounds were in areas with complex bathymetric features such as ridges, valleys, and deep holes. Fishing in these complex habitats is difficult, particularly with mobile gear, and requires *a priori* knowledge that the fishermen acquire through direct experience and information sharing. In some instances, cod spawning aggregations were reported to be associated with areas that held high concentrations of forage fish, such as herring, mackerel, or sand lance.

**Table 7.2. Frequency of biotic and abiotic habitat characteristics that fishermen associated with Atlantic Cod spawning grounds in the Gulf of Maine and on Georges Bank.**

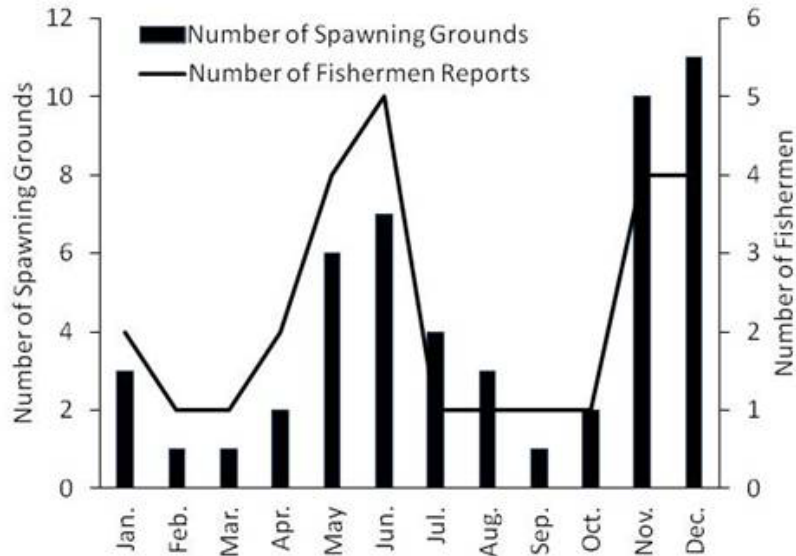
| Georges Bank and Nantucket Shoals |     |                           |    | Western Gulf of Maine      |    |
|-----------------------------------|-----|---------------------------|----|----------------------------|----|
| Abiotic Habitat Attributes        |     | Biotic Habitat Attributes |    | Abiotic Habitat Attributes |    |
| Sand or sand lumps                | 105 | Shellfish                 | 50 | Rocks and "hard" bottom    | 15 |
| Rocks and "hard" bottom           | 67  | Herring                   | 9  | Mud                        | 9  |
| Gravel                            | 36  | Mackerel                  | 3  | Gravel                     | 4  |
| Pebble and cobble                 | 11  | Sand lance                | 8  | Edges                      | 4  |
| Mud                               | 9   | Macroalgae                | 5  | Sand                       | 3  |
| Shipwrecks                        | 7   | Crabs                     | 1  |                            |    |
| Strong tides and currents         | 9   | Worms                     | 2  |                            |    |
| "Broken" bottom                   | 3   | Squid                     | 1  |                            |    |
|                                   |     | Silver hake               | 1  |                            |    |
|                                   |     | Sponges                   | 1  |                            |    |
|                                   |     | Sea Stars                 | 3  |                            |    |
|                                   |     | Small haddock             | 1  |                            |    |

The 10 fishermen interviewed as part of the Atlantic Cod Stock Structure Working Group project identified 22 spawning grounds in the Gulf of Maine, and some spawning grounds were recognized independently by multiple fishermen (Figure 7.6). The reported cod spawning sites included locations in Cape Cod Bay, Massachusetts Bay, Ipswich Bay, and on Jeffreys Ledge. Many of these spawning locations had been previously identified. For example, several fishermen identified spawning activity in the “Whaleback” area, which has been well documented (e.g., Bigelow and Schroeder, 1953; Howell et al., 2008; Howell, 2009). Winter spawning activity identified in Massachusetts Bay (Area 1C) was described by Bigelow and Schroeder (1953) and recently confirmed using acoustic telemetry (Zemeckis et al., 2019). The fishermen reported that cod spawning activity occurs across a wide range of depths in the western Gulf of Maine (Figure 7.5B).



**Figure 7.6. Map of the 22 Atlantic cod spawning grounds that were identified in the Gulf of Maine.**

While the fishermen identified cod spawning activity in the western Gulf of Maine throughout the year, seasonal peaks in spawning activity were evident in May and June, and again in November and December (Figure 7.7). The fishermen commonly referred to two spawning groups of cod in the western Gulf of Maine (“spring” and “winter” spawners), which is consistent with the available scientific information (see Dean et al., this TM).



**Figure 7.7. The number of Atlantic cod spawning grounds, and the number of fishermen that identified spawning activity in each month in the western Gulf of Maine.**

### *Temporal and Spatial Distribution of Cod Spawning – Eastern Gulf of Maine*

The 27 fishermen interviewed identified 14,594 hectares of historical inshore cod spawning grounds from Ipswich Bay to Grand Manan Channel (Ames 1998). These grounds were either channels or basins with gravel or gravel or sand substrates bordering muddy bottoms. Depths varied from than 30 to 100 meters, with some less than 30 meters and usually proximate with rocky bottom. Cod stocks in eastern Gulf of Maine (EGOM) collapsed in the mid-1990s. An extensive cod tagging project confirmed this (Tallack 2007) and the area continues to show few signs of recovery. NAFO Management Areas 511 and 512 in the eastern Gulf of Maine formerly included population components of the Gulf of Maine cod metapopulation that occupied grounds along the Maine coastal shelf from eastern Muscongus Bay to Grand Manan Channel in western Bay of Fundy. First-year and second-year cod are occasionally encountered but age-3 and older cod are uncommon in the Maine Center for Coastal Fisheries Sentinel Trawl Survey (Chen et al. 2016). Cod no longer return to the area seasonally nor are they known to reproduce there, though vestigial numbers of a cross-boundary cod group persists near Grand Manan Channel in eastern Management Area 511, as evidenced by catches in the Maine - New Hampshire Inshore Trawl Survey (Maine DMR).

Evidence associated with Management Area 512 indicated that at least two substocks of cod were formerly present in Penobscot Bay; one being a resident stock of large fish that arrived inshore in spring and a second arriving in June that had reproduced elsewhere and were there to feed. In the eastern Gulf of Maine, cod movements were persistent, following numerous deep channels towards shore in spring and moving further offshore along the same channels by fall, with resident fish remaining in adjacent deep water. The consensus of interviewees was that young juvenile cod were found close to shore and were relatively stationary, while older

juveniles and young adults were more mobile and wide-ranging; large cod remained inshore in deep water and were more sedentary.

Cod were found to occupy four relatively discrete subunits of the Gulf of Maine metapopulation north of Cape Ann. Each subunit utilized separate migration corridors and their abundance varied independently from its neighbors. Prior to collapse, historical movement patterns indicated that many cod remained on grounds in the collapsed area all year and reproduced in or near coastal estuaries. Others migrated from the area in fall and returned in spring (Perkins et al. 1996; Ames 2004). Each subpopulation was characterized by having multiple spawning sites where local reproduction occurred. The two cod subpopulation collapses in EGOM coincided with the loss of local cod spawning events.

### *Fishermen's Observations of Stock Structure and Connectivity*

The fishermen we interviewed during these projects had several observations related to the broad scale movements of Atlantic cod in the Gulf of Maine and on Georges Bank, and several common themes emerged during the discussions. Fishermen often expressed their concern that the current management units for cod in U.S. waters do not match the biological population structure of the resource. For example, five fishermen observed that they would commonly “follow” a body of cod from the waters east of Cape Cod into the western Gulf of Maine during their annual migration. They explained that they would begin to target cod off of Chatham in the early spring (March and April), and would follow the fish to the fishing grounds off Nauset in April and May, and finally to Stellwagen Bank in May and June. The fishermen remarked that this group of cod typically fed on sand lance. Similar observations were made during the outreach workshop in June, 2018. Another fisherman remarked that when fishing under Days at Sea with differential trip limits (i.e., higher daily catch allowance for the Georges Bank stock) they used to refer to the 42 line as a “joke”, because the cod were continuously distributed on either side of the stock boundary. Similarly, during the Georges Bank cod spawning interviews, 10 fishermen remarked that there is connectivity between cod in the western Gulf of Maine and the Great South Channel and Nantucket Shoals. These fishermen thought that cod would make regular seasonal migrations from the western Gulf of Maine to Nantucket Shoals and the Great South Channel, and that these movements were related to foraging behavior.

During the prior study (DeCelles et al., 2017) 15 fishermen remarked that they believe cod on eastern Georges Bank are distinct from those on Nantucket Shoals and western Georges Bank, and their conclusions were based on several observations. Many fishermen remarked on the discontinuous distribution of cod across Georges Bank. Fishermen often noted that cod on eastern Georges Bank often attained larger sizes than those taken inshore. Fishermen also consistently described differences in the color, shape, and fillet quality of cod between the two areas, and posited that the disparities in fillet qualities were related to the distinct diets of cod in these two regions. The geographic differences in the timing of spawning also reinforce these observations that cod on eastern and western Georges Bank are discrete groups. Many fishermen identified a longitudinal divide that they believe separate the two groups of cod on eastern and western Georges Bank cod, and most suggested a boundary line of either 68° W or 69°W, with

others suggesting that the Great South Channel acts as a boundary between inshore and offshore cod groups.

On a finer scale, some fishermen noted differences between the cod groups on Stellwagen Bank and Jeffreys Ledge. In particular, fishermen noted that the two groups of cod typically have different diets, with cod on Stellwagen Bank feeding primarily on sand lance, while those on Jeffreys Ledge mainly feed on herring and shrimp. The fishermen also commented that there are “localized groups” of cod in Ipswich Bay, which they can follow predictably during their seasonal migrations to the Whaleback spawning ground. However, further discussions are needed to better capture the details associated with this fine-scale structure.

A few fishermen with extensive experience fishing on Nantucket Shoals, primarily during the 1970’s and 1980’s, provided detailed descriptions of their understanding of cod movements on western Georges Bank. The fishermen recalled seeing “different runs of cod” on Nantucket Shoals throughout the year. The fishermen described a group of fish they called “groundskeepers”, which were resident cod that would remain on Nantucket Shoals throughout the year. The resident cod were joined seasonally on Nantucket Shoals by migrating fish. During the fall, migratory cod would move from the deeper waters of the Great South Channel, and perhaps from the western Gulf of Maine, towards Nantucket Shoals. The fishermen felt that these inshore movements may have been coincident with the first major winter storm (i.e., Nor’easter). The migratory cod would first arrive on the eastern portion of Nantucket Shoals (e.g., Davis Shoal and Johnson Shoal), and would move westerly across Nantucket Shoals as the winter progressed. Some of the migratory fish would remain on Nantucket Shoals to spawn, while other would migrate further westward to Noman’s and Cox Ledge, presumably to spawn there. The migratory fish would complete their return migration to the east in the summer and early fall. These seasonal observations of cod distribution and behavior around Nantucket Shoals are largely consistent with observations provided by early scientific studies (Smith 1902; Schreoder 1930; Wise 1958).

### *Fishermen’s Observations of Cod Morphology and Color*

Fishermen were observant of differences in the size and shape of cod between spawning groups. Two fishermen in the Gulf of Maine remarked that the spring spawning cod were generally “meatier” (i.e., higher yield) than those which spawned in the winter. One fisherman remarked that he regularly caught whale (i.e., very large) cod in the spring spawning aggregations, while whale cod were relatively rare in the winter spawning aggregations. Several fishermen remarked that the cod on eastern Georges Bank were generally larger than those taken on western Georges Bank, and that the largest cod they encountered were on eastern Georges Bank.

The fishermen reported that red cod were common throughout the Gulf of Maine, and that they were often captured in close proximity to areas with hard bottom habitat (e.g., rock piles). Red cod were reported to occur in multiple locations, ranging from areas close to shore off of New Hampshire and Massachusetts, to depths of 70 fathoms in Ipswich Bay. The fishermen remarked that red cod and olive cod were often caught together in feeding aggregations, and that red cod generally comprised a small proportion (e.g., <5%) of the total

cod catch. Interestingly, the fishermen reported that they did not recall catching red cod in spawning condition, and that red cod were only captured in feeding aggregations. One fisherman remarked that the red cod he captured were generally smaller than the olive cod.

### *Other Recurrent Topics of Interest Related to Cod Biology*

Several fishermen commented that they have observed truncation of the size structure of cod over the course of their careers, both in the Gulf of Maine and on Georges Bank. Some fishermen expressed concern that the loss of older and larger spawners had an effect on the cod behavior, and reduced the spatial stability of the spawning aggregations. As one fisherman commented, “The younger cod have no one to lead them home”, while another lamented that intense fishing on Nantucket Shoals had “wiped the genetic memory out of the fish”. A few fishermen also remarked that they observed declines in the size at maturity for cod during their careers.

Unsurprisingly, climate change and water temperature were recurrent topics during the interviews. The majority of fishermen noted that they have observed long-term changes in water temperature, and they expressed concern that warming waters were deleterious to the productivity of cod. Many fishermen felt that cod were especially sensitive to water temperature, and observed that the distribution of spawning activity changes in response to temperature. For example, several fishermen commented that spawning activity has shifted to deeper waters in Ipswich Bay in recent years, and implicated climate change as the likely driver. Others noted that the exact location of spawning will change from year to year, dependent upon temperature, with cod often seeking out the coldest available habitats to spawn.

## **Discussion**

### *Insights into Cod Population Structure from FEK*

This case study provides a valuable example of how FEK can serve as a complement to enhance our understanding of stock structure. Fishermen’s observations related to the timing and location of cod spawning on Georges Bank were well supported by the existing scientific information (see detailed reviews in DeCelles et al. 2017a, b). The fishermen also identified some cod spawning grounds that were not previously described in scientific reports. Further, many fishermen possessed a detailed understanding of cod movement patterns, and geographic variation in cod morphology, diet, and coloration. The level of spatial resolution provided by FEK cannot be easily obtained using traditional scientific data collection approaches.

Several fishermen remarked that there was connectivity between cod in the western Gulf of Maine, and cod on Nantucket Shoals and in the Great South Channel. Their observations are well aligned with the tagging results from Wise (1963), who found that 15% of cod tagged off of Chatham in March and April were later recaptured in the Gulf of Maine. Loehrke (2012) noted that cod tagged east of Cape Cod (off Chatham, and in the Great South Channel) exhibited dispersive movements, and observed that the interpretation of the movement patterns was dependent upon whether the recaptures were weighted by geographic differences in fishing

effort. While cod released east of Cape Cod were observed to disperse to southern New England Georges Bank, and the Gulf of Maine, the principal direction of movement was northwest, into the western Gulf of Maine. Tallack (2011) observed that sublegal cod tagged east of Cape Cod exhibited two major movement patterns, with some individuals migrating eastward towards Georges Bank, and others moving northwards into the western Gulf of Maine. Trawl survey data demonstrate that cod are continuously distributed from the western Gulf of Maine to the east of Cape Cod and into the Great South Channel (Begg et al. 1999; McBride et al., this TM). Using a suite of genetic markers Kovach et al (2010) identified a “Southern Complex” of cod, which included winter spawning cod in Massachusetts Bay and Ipswich Bay, and winter spawning cod on Cox Ledge and Nantucket Shoals.

Many fishermen expressed their opinion that cod on eastern Georges Bank are distinct from those on Nantucket Shoals and in the Great South Channel. Their observations are congruent the results of with several tagging studies. Schroeder (1930) reported that cod tagged on Nantucket Shoals were rarely recaptured on Georges Bank east of 68° W. Wise (1963) reported that few cod tagged off Chatham were later recaptured on eastern Georges Bank, and that no cod tagged on eastern Georges Bank were recaptured in the Great South Channel or Nantucket Shoals. Many fishermen suggested that the longitudinal division between cod on eastern and western Georges Bank was either 69° W or 68° W, and Wise (1963) similarly suggested the population division occurs at 68° W. Similarly, Hunt et al. (1999) noted that very few cod tagged on eastern Georges Bank were recaptured in the Great South Channel, and that none were recaptured on Nantucket Shoals. Tallack (2011) reported that cod tagged on eastern Georges Bank made extensive movements to the Scotian Shelf, but rarely moved to Nantucket Shoals or the Great South Channel. Based on NEFSC trawl survey data Begg et al. (1999) also documented a discontinuous distribution of cod between eastern and western Georges Bank, which was most pronounced during the autumn survey, particularly between 1989 and 1997. However, the fishermen’s observations that cod on eastern Georges Bank were larger than those on western Georges Bank did not match the von Bertalanffy growth parameters reported by Begg et al. (1999), which consistently estimated a larger  $L_{\infty}$  for cod on western Georges Bank. Several studies have indicated that genetic differences exist between cod on eastern Georges Bank and those on Nantucket Shoals (Lage et al., 2004; Wirgin et al., 2007; Kovach et al., 2010).

### *How Fisheries Management Influences FEK*

Fishermen’s observations related to the timing and location of cod spawning activity are undoubtedly influenced by fishery management and regulations. Under Days-at-Sea management, many fishermen targeted cod aggregations because they could maximize their catch per unit effort and revenue, and make trips close to shore that would allow them “to beat the clock”. Since the transition to sector management in 2010, and the quotas cuts that followed, the majority of active fishermen reported that they no longer target cod because of the low allocations, and high lease prices, in recent years. Spatial regulations have also had a substantial influence over when and where fishermen can target cod. Closed areas that were implemented in U.S. waters to reduce fishing mortality (e.g., Closed Areas I and II, Cashes Ledge), or to protect habitat (e.g., Nantucket Shoals habitat closure) have prohibited fishing in many of the areas where the U.S. fleet used to target spawning cod. In addition to the year-round closed areas, a number of seasonal closures have been implemented in the Gulf of Maine to protect cod

spawning activity (e.g., Whaleback, Winter Cod Conservation Zone) and “rolling” closures have been used to limit fishing mortality on cod and other groundfish. Many of these closures have been altered over time as new information has become available and management priorities have changed. U.S. fishermen have been banned from fishing on eastern Georges Bank since the Hague Line was established in 1984. On the Canadian portion of eastern Georges Bank, the Canadian trawl fleet is required to use selective fishing gear (e.g., haddock separator trawl) which is designed to reduce cod bycatch, and fishing is typically prohibited from early February through May to protect spawning cod (Wang et al., 2015). In addition, fishermen from the Gulf of Maine and Cape Cod have noted that the quantity of lobster traps has increased substantially in the last decade, and that the spatial footprint of the lobster fishery has expanded further offshore and into deeper water. As a result, many of areas where trawl fishermen formerly targeted cod are no longer available to them, which further limits their ability to understand cod movements and spawning behavior. In combination, these factors make it difficult for fishermen to assess the current spatial and temporal extent of cod spawning on Georges Bank and in the Gulf of Maine. Unfortunately, in many cases these limitations also make it difficult to understand whether historical spawning grounds have been extirpated. Therefore, it is important to recognize that FEK can only provide a partial picture of cod spawning behavior and stock structure, and that the greatest utility of FEK will be realized when it is considered in conjunction with traditional scientific information.

Fishery regulations, particularly the fear of additional regulations, may also influence whether a fishermen will choose to share their knowledge (Pederson and Hall Arber 1999; Maurstad 2002; Bergmann et al. 2014). During the Georges Bank interviews, 40 of the 52 fishermen we contacted agreed to complete an interview. The high participation rates were likely due to several factors (see DeCelles et al. 2017b), and many of the fishermen we collaborated with were retired, which may have increased their willingness to share information. However, some fishermen in the western Gulf of Maine were more guarded in providing their information. Several refused to complete an interview, and others who did complete an interview were sometimes unwilling to share spatial information related to cod spawning. Therefore, the spawning grounds identified in the western Gulf of Maine are not exhaustive. However, based on the discussion during the interviews, it is evident that fishermen in the western Gulf of Maine have a detailed understanding of cod distribution, morphometrics, and spawning activity, and further research and outreach would be valuable to investigate fine-scale population structure in the Gulf of Maine. Nevertheless, the insights that fishermen shared during the interviews can provide valuable information when considering the biological structure of regional cod populations.

## **Conclusion**

Fishermen in the Gulf of Maine and Georges Bank have a detailed understanding cod behavior, including their seasonal movement patterns and spawning locations. This knowledge can provide critical insights into the population structure of cod in U.S. waters, and should be given formal consideration as part of a multidisciplinary stock identification study. The observations of fishermen collected during the semi-structured interviews largely supports the



emerging view that cod on eastern Georges Bank are largely distinct from groups on western Georges Bank and southern New England.

## Acknowledgments

We thank David Martins, Doug Zemeckis, and Steve Cadrin for their substantial contributions to this chapter. David, Doug, and Steve all assisted with the design and execution of the interviews and contributed extensively to the analysis and interpretation of the results. This work would not have been possible without their assistance. Crista Bank assisted with the Georges Bank interviews, and traveled to Nova Scotia to interview Canadian fishermen. We are indebted to the fishermen who generously shared their time and knowledge with us, and who patiently answered our questions. We are especially grateful to Gilbert Donaldson, who helped us contact fishermen in Nova Scotia and schedule interviews. Funding for the forty Georges Bank interviews was provided by the New England Fishery Management Council through a grant administered by the Northeast Consortium. Data requests were fulfilled by Sean Lucey, and Jon Hare at the NOAA Northeast Fisheries Science Center, and Yanjun Wang and Irene Andruschenko at the Canadian Department of Fisheries and Oceans.

## References Cited

- Ames T. 1998. Cod and haddock spawning grounds in the Gulf of Maine from Grand Manan Channel to Ipswich Bay. *In* The Implications of Localized Fisheries Stocks, pp. 55-64. Ed. by I.H. von Herbing, and M. Tupper. Natural Resource, Agriculture, and Engineering Service, Ithaca, New York. 200 pp.
- Ames EP. 2004. Atlantic cod stock structure in the Gulf of Maine. *Fisheries* 29(1): 10-28.
- Begg GA, Hare JA, Sheehan, DD. The role of life history parameters as indicators of stock structure. *Fisheries Research* 43: 141-163.
- Bergmann M, Hinz H, Blyth RE, Kaiser MJ, Rogers SI, Armstrong M. 2004. Using knowledge from fishers and fisheries scientists to identify possible groundfish 'Essential Fish Habitats'. *Fisheries Research* 66: 373-379.
- Berkes F, Colding J, Folke C. 2000. Rediscovery of traditional ecological knowledge as adaptive management. *Ecological Applications* 10(5): 1251-1262.
- Bigelow H, Schroeder WC. 1953. Fishes of the Gulf of Maine. Fishery Bulletin of the Fish and Wildlife Service.
- Chen Y, Rodrigue M, Alden R, Shapard, P. Eastern Gulf of Maine Sentinel Survey 2010-2016. Final Report. Maine Center for Coastal Fisheries. Available from: <https://coastalfisheries.org/collaborative-research/groundfish-research/>.
- DeCelles G, Martins D, Zemeckis DR, Cadrin SX. 2017a. Using fishermen's ecological knowledge to map Atlantic cod spawning grounds on Georges Bank. *ICES Journal of Marine Science* 74(6): 1587-1601.

DeCelles G, Martins D, Zemeckis DR, Cadrin SX. 2017b. Mapping the distribution of Atlantic cod spawning on Georges Bank using Fishermen's Ecological Knowledge and scientific data. Final report submitted to the Northeast Consortium. Available from: [http://s3.amazonaws.com/nefmc.org/7\\_Cadrin-GB-cod-final-report.pdf](http://s3.amazonaws.com/nefmc.org/7_Cadrin-GB-cod-final-report.pdf).

Figus E, Carothers C, Beaudreau AH. 2017. Using local ecological knowledge to inform fisheries assessment: measuring agreement among Polish fishermen about the abundance and condition of Baltic cod (*Gadus morhua*). ICES Journal of Marine Science 74(1): 2213-2222.

Goode GB. 1887. The fisheries and fishing industry of the United States. Section III: The fishing grounds of North America with forty-nine charts. United States Commission of Fish and Fisheries.

Hedeholm RB, Jacobsen RB, Nielsen EE. 2016. Learning from 'apparent consensus' in TAC disputes: exploring knowledge overlaps in LEK and genetic categorization of Atlantic cod. Marine Policy 69: 114-120.

Hind EJ. 2015. A review of the past, the present, and the future of fishers' knowledge research: a challenge to established fisheries science. ICES Journal of Marine Science 72(2), 341-358.

Howell, WH, Morin, M, Rennels, N, Goethel, D, 2008. Residency of adult Atlantic cod (*Gadus morhua*) in the western Gulf of Maine. Fisheries Research 91 (2-3), 123-132.

Howell, WH. 2009. Activity and distribution of cod in the Ipswich Bay spawning area. Final Report. Northeast Consortium Award 111A22.

Hunt JJ, Stobo WT, Almeida F. 1999. Movement of Atlantic cod, *Gadus morhua*, tagged in the Gulf of Maine area. Fishery Bulletin 97: 842-860.

Johannes RE, Freeman MMR, Hamilton RJ. 2000. Ignore fishers' knowledge and miss the boat. Fish and Fisheries 1: 257-271.

Kovach AI, Breton TS, Berlinsky DL, Maceda L, Wirgin I. 2010. Fine-scale spatial and temporal genetic structure of Atlantic cod off the Atlantic coast of the USA. Marine Ecology Progress Series 410: 177-195.

Lage C, Kuhn K, Kornfield I. 2004. Genetic differentiation among Atlantic cod (*Gadus morhua*) from Browns Bank, Georges Bank, and Nantucket Shoals. Fishery Bulletin 102: 289-297.

Loehrke JL. 2013. Movement patterns of Atlantic cod (*Gadus morhua*) spawning groups off New England. MS Thesis, University of Massachusetts, Dartmouth, MA, USA.

Macdonald P, Angus CH, Cleasby IR, Marshall CT. 2014. Fishers' knowledge as an indicator of spatial and temporal trends in abundance of commercial fish species: megrim (*Lepidorhombus whiffiagonis*) in the northern North Sea. Marine Policy 45, 228-239.

Maine Department of Marine Resource (DMR). Maine - New Hampshire Inshore Trawl Survey Reports and Publications. Available from: <https://www.maine.gov/dmr/science-research/projects/trawlsurvey/reports/index.html>.

Maurstad A. 2002. Fishing in murky waters: ethics and politics of research on fisher knowledge. Marine Policy 26: 159-166.

Murray G, Neis B, Schneider DC, Ings D, Gosse K., Whalen J, Palmer CT. 2008a. Opening the black box: methods, procedures, and challenges in the historical reconstruction of marine social-ecological systems. *In Making and Moving Knowledge: Interdisciplinary and Community-Based Research in a World on the Edge*, pp. 100-120. Ed. by J.S. Lutz, and B. Neis. McGill-Queen's University Press, Montreal. 360 pp.

Murray G, Neis B, Palmer CT, Schneider DC. 2008b. Mapping cod: fisheries science, fish harvesters' ecological knowledge and cod migrations in the northern Gulf of St. Lawrence. *Human Ecology* 36: 581-598.

Neis B. 1998. Fishers' ecological knowledge and the identification and management of localized populations of Atlantic cod (*Gadus morhua*) in northeast Newfoundland. *In The Implications of Localized Fisheries Stocks*, pp. 177-188. Ed. by I.H. von Herbing, and M. Tupper. Natural Resource, Agriculture, and Engineering Service, Ithaca, New York. 200 pp.

Neis B, Felt LF, Haedrich RL, Schneider DC. 1999a. An interdisciplinary method for collecting and integrating fishers' ecological knowledge into resource management. *In Fishing Places, Fishing People: Traditions and Issues in Small-Scale Canadian Fisheries*, pp. 217-238. Ed. by D. Newell and R.E. Ommer. University of Toronto Press, Toronto. 412 pp.

Neis B, Schneider DC, Felt L, Haedrich RL, Fischer J, Hutchings, JA. 1999b. Fisheries assessment: what can be learned from interviewing resource users? *Canadian Journal of Fisheries and Aquatic Sciences* 56: 1949-1963.

Pederson J, Hall-Arber M. 1999. Fish habitat: a focus on New England fishermen's perspectives. *American Fisheries Society Symposium* 22: 188-211.

Perkins HC, Chenoweth SB, Langton RW. 1996. The Gulf of Maine Atlantic Cod Complex, patterns of distribution and movement of the Sheepscot Bay Substock. *Bulletin of the National Research Institute for Aquaculture. Supplement.* 3:101-107.

Rich WH. 1929. Fishing grounds of the Gulf of Maine. U.S. Department of Commerce, Bureau of Fisheries, Report of the United States Commissioner of Fisheries.

Schroeder WC. 1930 Migrations and other phases in the life history of the cod off southern New England. *Bulletin of the Bureau of Fisheries*, Vol. XLVI: 1-136.

Silvano RAM, MacCord PFL, Lima RV, Begossi A. 2006. When does this fish spawn? Fishermen's local knowledge of migration and reproduction in Brazilian coastal fishes. *Environmental Biology of Fish* 76: 371-386.

Smith HM. 1902. Notes on the tagging of four thousand adult cod at Woods Hole, Massachusetts. U.S. Commission of Fish and Fisheries, Part XXVII. Report of the Commissioner for the year ending June 30, 1901. pp. 193-208.

Stephenson RL, Paul S, Pastoors MA, Kraan M, Holm P, Wiber M, Mackinson S, Dankel DJ, Brooks K, Benson A. 2016. Integrating fishers' knowledge research in science and management. *ICES Journal of Marine Science* 73(1): 1459-1465.

Tallack SML. 2011. Stock identification applications of conventional tagging data for Atlantic cod in the Gulf of Maine. In Proceedings from the 2nd International Symposium on Advances in Fish Tagging and Marking Techniques, pp. 1-15. Ed. by J. McKenzie, B. Parsons, A.C. Seitz, R.K. Kopf, M. Mesa, and Q. Phelps. American Fisheries Society, Auckland, NZ.

Wang Y, O'Brien L, Andrushchenko I. 2015. Assessment of Eastern Georges Bank Atlantic Cod for 2015. TRAC Reference Document 2015/03. Available from:  
[https://www.nefsc.noaa.gov/saw/trac/TRD\\_2015\\_03\\_E\\_cod.pdf](https://www.nefsc.noaa.gov/saw/trac/TRD_2015_03_E_cod.pdf).

Wirgin I, Kovach AI, Maceda L, Roy NK, Waldman J, Berlinsky DL. 2007. Stock identification of Atlantic cod in U.S. waters using microsatellite and single nucleotide polymorphism DNA analysis. *Transaction of the American Fisheries Society* 136: 375-391.

Wise JP. 1958. The world's southernmost indigenous cod. *Journal Cont. Exploration de la Mer*. 23:208-212.

Wise JP. 1963. Cod groups in the New England area. *Fishery Bulletin* 63: 189-203.

Yates KL. 2014. View from the wheelhouse: perceptions on marine management from the fishing community and suggestions for improvement. *Marine Policy* 48: 39-50.

## 9. SYNTHESIS

McBride, R., E. Ames, I. Andrushchenko, S. Cadrin, J. Cournane, M. Dean, G. DeCelles, L. Kerr, A. Kovach, N. Overgaard Therkildsen, G. Puncher, K. Smedbol, Y. Wang, and D. Zemeckis

Previous chapters reviewed various disciplinary perspectives to reconsider the stock structure of US Atlantic cod. In this synthesis chapter, the ACSSWG evaluates a plausible set of hypotheses representing biological stock structure of cod, and identifies the stock structure hypothesis with the greatest scientific support, one that is likely to be temporally stable and accurately captures the available data and assessment model frameworks.

The following reference criteria, typically assumed in stock assessments, were used for evaluating plausible biological stock structures of cod:

1. Defining a unit stock as reproductively isolated, where the source of recruitment is from within the stock boundary, with little or no immigration and emigration of individuals across the stock boundary,
2. Considering a dynamic pool of individuals within a stock, where classes of age, length, or sex have homogeneous vital rates (e.g., growth, mortality, maturity, fecundity),
3. Abundance estimates, or aspects of demographics, are based on samples from a well-mixed population.

Stocks identified by these criteria may or may not be spatially distinct. When spatial overlap occurs, mixed-stock fisheries result.

We begin by defining aspects of the current management units, then listing conclusions that reject these current management units as an accurate representation of the biological stock structure of cod.

### The current management unit framework

As outlined in the Introduction (Chapter 1), aligning cod management units to reflect biological stock structure occurred over several decades and used an interdisciplinary set of research. The current management units conform largely to NAFO Divisions, which are composed of statistical areas used for reporting fishery catch (Chapter 2). Cod distributed in Division 5, with statistical areas in the 500s, are considered in US waters, with the exceptions outlined in Figure 9.1.

The NAFO statistical area framework is foundational for aggregating fishery monitoring data. The ACSSWG accepts this and presents their conclusions in terms of these statistical areas, with the intent for their proposal to be more readily adopted by monitoring, assessment, and management actions. Also considered as an alternative spatial framework was 10' squares of latitude-longitude; however, this scale is not supported by all fishery monitoring data and many regions of Division 5 do not have data relevant for stock identity at that spatial scale, so this finer scale was judged as less likely to be adopted by end users.

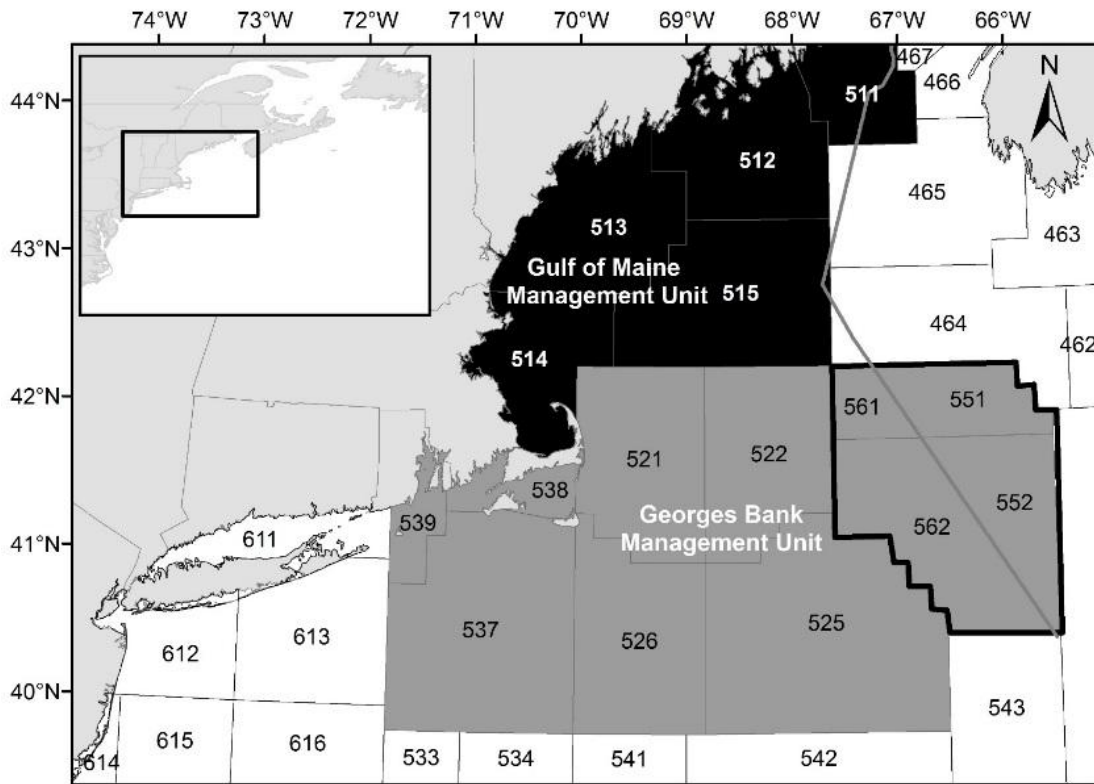


Figure 9.1. Current boundaries for the two US Atlantic cod management units – Gulf of Maine (black polygons) and Georges Bank (gray polygons) – both within the Northwest Atlantic Fisheries Organization (NAFO) Division 5. The individual polygons are ‘statistical areas,’ used to aggregate fishery catch data. Statistical areas designated in the 500s and 600s (NAFO Division 6) are in US waters, and those in the 400s (NAFO Division 4X) are in Canadian waters. Note, however: 1) cod catches attributed to NAFO Division 6 are assigned to the Georges Bank US management unit; 2) areas 551-2 are in Canadian waters, and together with US areas 561-2, these four areas (outlined in black) are assessed and managed jointly between the United States and Canada under the auspices of the Transboundary Resources Assessment Committee (TRAC); and 3) the gray line running from area 511 and south through the TRAC area is the Hague line, the US-Canadian maritime border. Catches on the US side of the Hague line in areas 464, 465, and 511 are assigned to the Gulf of Maine unit, whereas catches on the Canadian side of the Hague line in these areas are assigned to Canada.

## Mismatches between current management units and biological stock structure

We outline below, several observations about cod trait heterogeneity, genetic variation, movements, spawning locations and seasons, and dispersal of larvae all of which lead the

ACSSWG to reject the current management units as an accurate representation of cod stock structure within the region.

1. Atlantic cod in US waters exhibit extensive phenotypic heterogeneity inconsistent with the current management units. As an example that cod are not well mixed within each management unit, cod traits in the eastern part of the Georges Bank management unit vary markedly compared to cod traits in the western part of the Georges Bank management unit, including different spawning seasons (Chapters 3 and 8), growth rates (Chapter 5), and morphometrics (Chapter 6). As an example that cod mix between current management units, cod in the Great South Channel part of the Georges Bank Management Unit are more likely to share characteristics with cod in the southwestern Gulf of Maine and southern New England, such as similar spawning seasons (Chapters 3 and 8) and growth rates (Chapter 5). As an example of mixed stocks overlapping within a management unit, cod natural markers (otolith chemistry, structure and morphometrics (Fig. 9.2) indicate winter and spring spawners as unique groups within the Gulf of Maine management unit (Chapter 6).

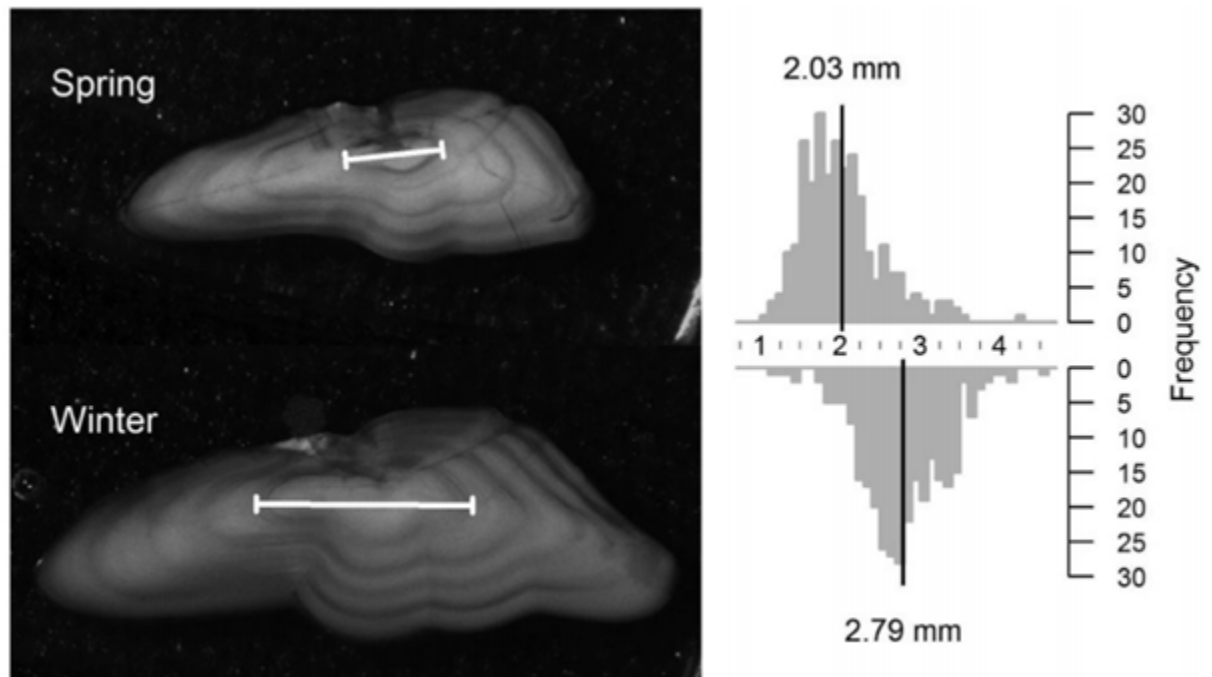


Figure 9.2 Winter and spring spawning cod, from the same management unit [Gulf of Maine], have different mean diameter measures of the first annulus. [Left] Otolith cross-sections from 2 age-4 cod, both captured in spawning condition. The one at top was captured in May, while the one at bottom was captured in December. The diameter of the first (A1) annulus is identified. [Right] Histograms of otolith A1 diameter (mm) from the training dataset, for spawning cod captured in spring (top,  $n = 278$ ) and winter (bottom,  $n = 301$ ); mean values are identified by the dark vertical line (Dean et al. 2019).

- Atlantic cod in US waters also exhibit extensive genetic connectivity between as well as heterogeneity within the current management units (Chapter 4). For example, cod in the eastern part of the Georges Bank Management Unit (Georges Bank) are genetically distinct from cod in the western part of that Management Unit (Great South Channel, Nantucket Shoals, and southern New England), and cod in the Cape Cod area (area 521, currently in the Georges Bank Management Unit) are more genetically similar to cod in the Gulf of Maine than to cod on Georges Bank or southern New England (Fig. 9.3). Mixed stocks overlap in one area, the western part of the Gulf of Maine Management Unit, where cod are comprised of two genetically distinct populations with different reproductive phenologies (i.e., winter vs. spring spawners). The genetic differences between winter and spring spawners include regions of the genome that contain adaptive variation, including genes that may underlie a genetic basis for spawning time (Chapter 4). This evidence for sympatric spawning groups in this area is well supported by other disciplines such as the early life history (Chapter 3), natural markers such as the width of otolith annuli (Chapter 6), electronic tagging (Chapter 7), and fisherman’s ecological knowledge (Chapter 8). Spatial overlap of genetically distinct populations within the Gulf of Maine management unit has broad implications because it disrupts the spatial delineation of stock structure with mixed-stock fisheries at a fine scale (i.e., within single statistical areas, such as 514).

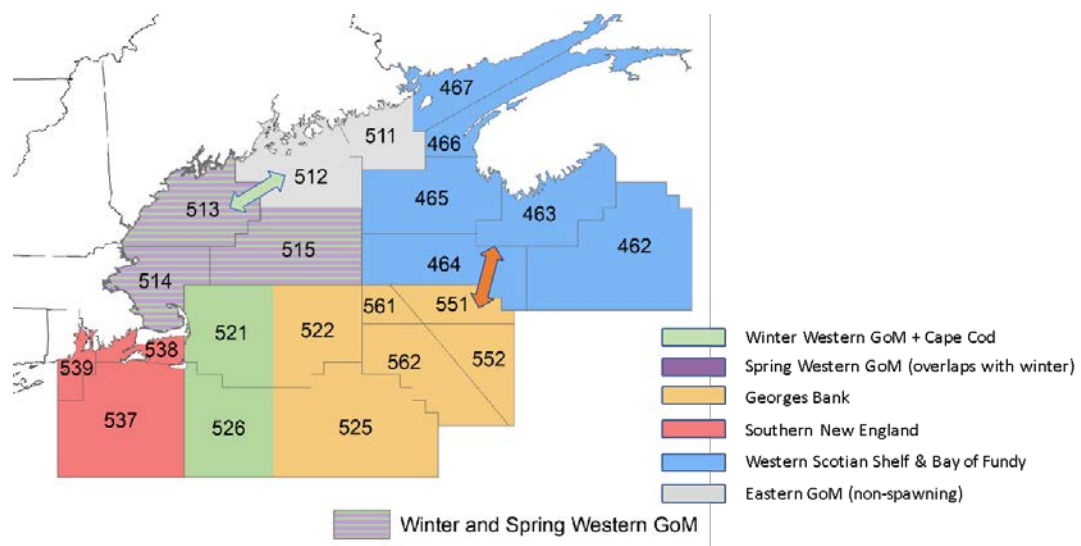


Figure 9.3. Population genetic structure of cod in NAFO divisions 5 and 4X, based on synthesis of all available data. The hatched polygons comprised by areas 513, 514 and 515 denote genetically distinct winter and spring spawning populations occurring in sympatry. Arrows indicate areas of connectivity between populations.

- Adult cod in some areas are relatively sedentary, whereas adults in other areas exhibit extensive movements, including swimming between current US-US and US-Canada management units (Figure 9.4, Chapter 7). Adult cod that spawn in the southwestern Gulf



of Maine are largely sedentary, with some movement to the Great South Channel, whereas cod in northeastern Gulf of Maine (e.g., 511) have, at least historically, moved across the US-Canadian boundary into various statistical areas of Division 4X (Chapter 7). Adult cod exhibit significant transboundary movements between the US side of Georges Bank and the Canadian Browns Bank, whereas adult cod in southern New England are primarily residential within that area with some movement with Nantucket Shoals and Great South Channel. These patterns of movement are remarkably stable over time. Some major movement patterns have persisted since the earliest tagging studies, and inferences of movement are similar from tagging studies since the 1970s.

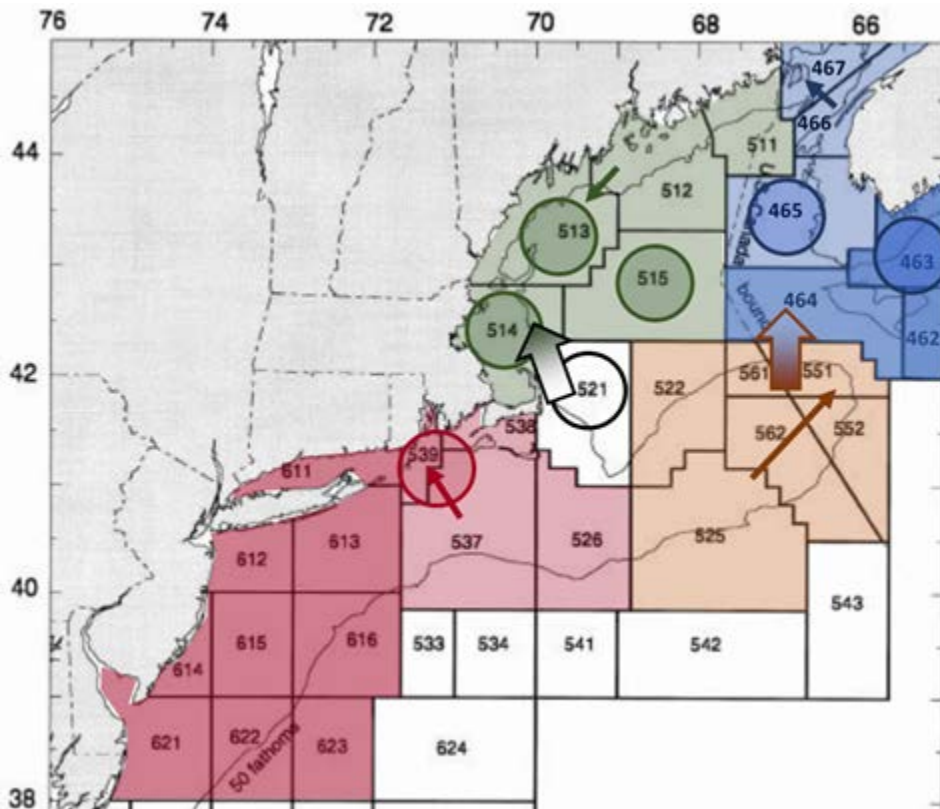


Figure 9.4. Major patterns of movement among regions (multicolor arrows: >10% regional movement), movement within regions (solid colored arrows: >50% movement from statistical area), and residence within statistical areas (circles: >50% residence in statistical area) from combined tagging studies.

4. Fidelity to spawning grounds/seasons is evident for each major spawning group, but the spatial extent of movement away from spawning grounds during non-spawning seasons varies (Chapter 7). Analysis of residence and dispersal of distinct spawning groups among fishing grounds suggest high residence and fidelity to spawning areas in the western Gulf of Maine and the Bay of Fundy, dispersal of Cape Cod spawners into both US management units, and dispersal of eastern Georges Bank spawners on both sides of

the Hague line. Major movement patterns are consistent among studies and across recent decades of tagging studies, but the frequency of residence and movement vary.

Although winter and spring spawning groups in the western Gulf of Maine show a high degree of residency, there is some evidence that these groups have different spatial ecology and movements while remaining resident within this area (Chapter 6), in addition to being offset in the timing of their seasonal inshore-offshore migration patterns.

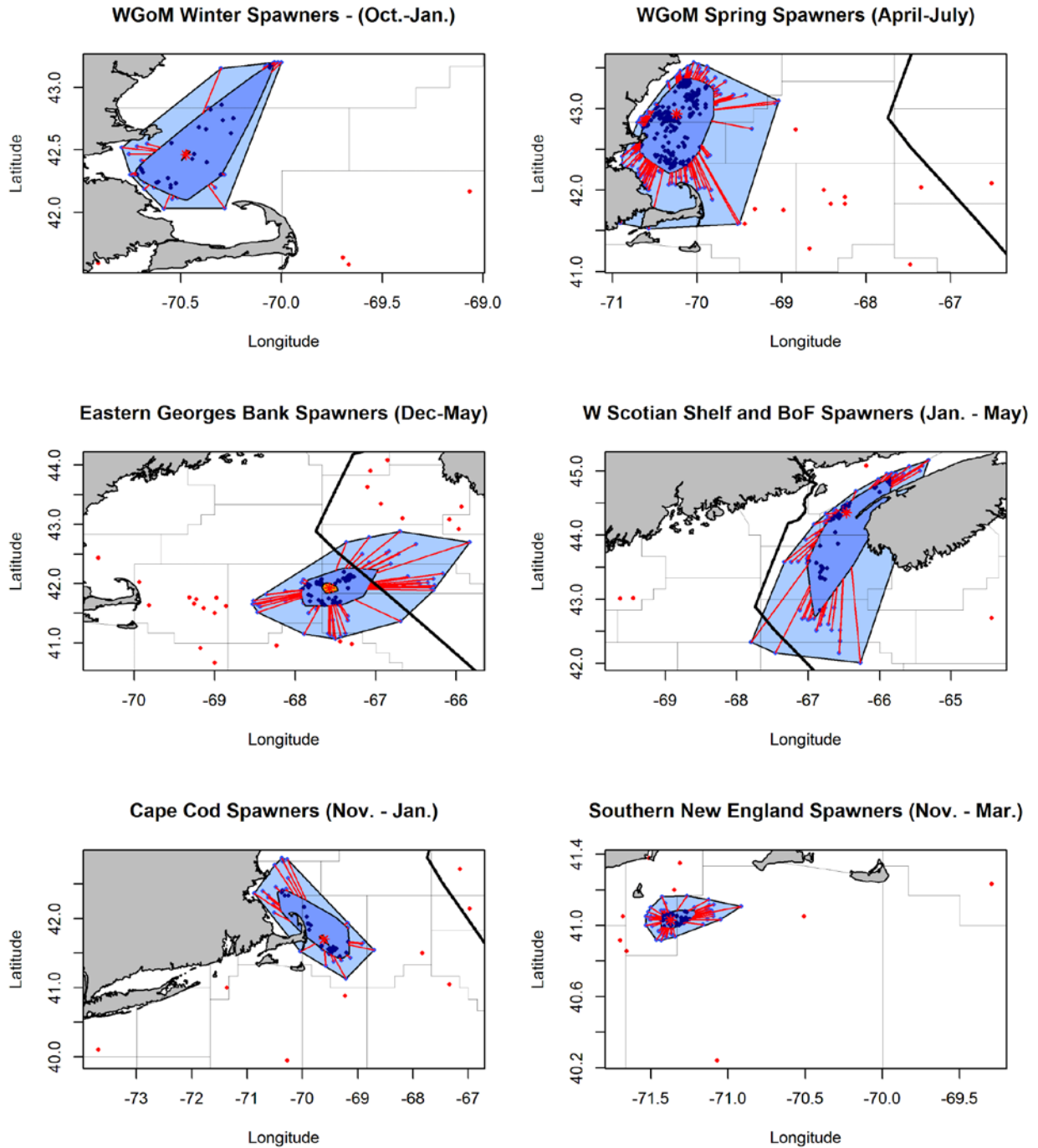


Figure 9.5. Bagplots depicting the location of cod recaptures for each of the major spawning groups during their respective spawning seasons. The bagplots only include cod that were at large for >4 months, and are intended to depict site fidelity, and straying behavior, during the spawning season. Some spawning groups (e.g., Southern New England) exhibit high rates of site fidelity, while others (e.g., Eastern Georges Bank) are more dispersive. The bagplot depicts the median recapture position (red asterisk), area with 50% of recaptures (dark blue), approximately 95% of recaptures (light blue) and outliers (red dots). Abbreviations used: WGoM (western Gulf of Maine), W Scotian Shelf and BoF (Western Scotian Shelf and Bay of Fundy).

5. Spring- and winter-spawned cod larvae are dispersed around Cape Cod from the western part of the Gulf of Maine management unit to the western part of the Georges Bank management unit (Fig. 9.6, Chapter 3). Larvae from the winter spawning season are dispersed further into southern New England than larvae from the spring spawning.

| Spawning Area | Settlement Area |    |     |     |
|---------------|-----------------|----|-----|-----|
|               | GOM             | CC | SNE | GBK |
| GOMS          | C               | C  | X   | X   |
| GOMW          | C               | C  | c   | X   |
| CC            | X               | X  | C   | X   |
| SNE           | X               | X  | C   | X   |
| GBK           | X               | X  | c   | C   |

C = major connectivity  
c = minor connectivity  
X = unlikely connectivity

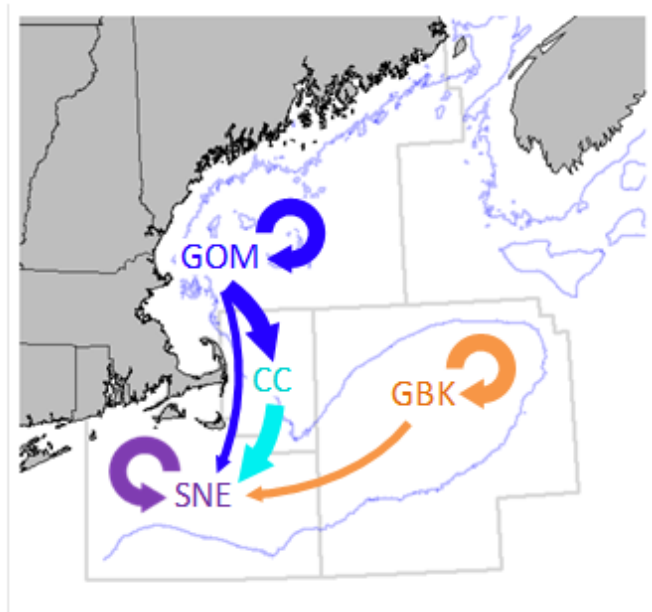


Figure 9.6. Summary of the early life connectivity between areas for Atlantic cod in US waters. “GOMS” and “GOMW” indicate spring and winter-spawning groups in the Gulf of Maine, respectively. Gulf of Maine (GOM) area: stat. areas 511-515; Cape Cod (CC) area: stat. area 521; Georges Bank (GBK) area: stat. areas 551, 552, 561, 562, 522, 525 ; Southern New England (SNE) area: stat. areas 526, 537-539.

6. The status of some regions is still poorly known, especially the eastern Gulf of Maine. Eastern Maine cod have been depleted for decades making it difficult to sample spawning cod to clarify this region’s position in terms of biological stock structure (Chapters 1, 4, 8). However, historical records indicate that both winter and spring spawning cod were present along coastal Maine in the 1940s (Ames, 1997). The limited tagging data

available from this region suggests greater connectivity between eastern Maine (area 511) and the Scotian Shelf than with the rest of the Gulf of Maine (Chapter 7). Genetic data from non-spawning cod in area 512 suggest contemporary movement between this area and area 513.

In summary, the current spatial boundaries of management units fail to account for considerable phenotypic and genetic heterogeneity from the western to eastern ends of the Georges Bank management unit, and additional heterogeneity within the Gulf of Maine management unit. Nor does it account for the considerable connectivity of larvae and movements by adults between these management units around Cape Cod, and the existence of two genetically distinct sympatric populations.

## Evaluation of alternative hypotheses

Having rejected the current management units as the most accurate representation of cod biological structure, we consider alternatives that add biological complexity.

An alternative, yet still simple two-stock model splits the US range of cod into inshore and offshore management units, rather than north-south management units. This choice arises from the many traits of cod in the eastern part of the Georges Bank management unit (George Bank) that differ from cod in other areas, such as discrete spawning areas (Chapters 3, 8), genetic differentiation (Chapter 4), differences in growth and maturity (Chapter 5), etc. Elsewhere in the Atlantic there are examples of inshore versus offshore stock delineations of cod, including off Newfoundland (Smedbol and Stephenson 2001), off Iceland (Pampoulie et al., 2006), and the Norwegian coast (Northeast Arctic cod and Norwegian coastal cod, Berg et al. 2016). Still, recognition of inshore-offshore biological stock structure has not always led to two management units. For example, in Canada, the northern cod (2J3KL) has inshore and offshore spawning components, with complex annual spawning and feeding migrations, and genetic differences; however, it is assessed and managed as one stock (DFO 2018). Nonetheless, the eastern part of the Georges Bank Management Unit is already treated separately, as part of the US-Canadian Transboundary Resource Assessment Committee, at least partly because of the movements of cod across the US-Canadian boundary (Fig. 9.4).

A specific boundary to delineate western and eastern portion of the Georges Bank Management Unit has been subject of historical debate. The hydrodynamics in this region isolate Georges Bank as self-contained, anti-cyclonic gyre east of the Great South Channel which would serve as a foundational setting that could keep inshore and offshore cod separated (Fig. 9.7a). Wise (1963) proposed a boundary at 68°W, but this would split statistical fishing areas 522 and 525, which would introduce its own uncertainty, something the ACSSWG has avoided in this process. Fishermen have also proposed various boundaries, such as at 68°W, 69°W, or the Great South Channel (Chapter 8). As recently as a few years ago, Zemeckis et al. (2014) stated: additional research is needed 'to determine the natal origin of cod caught in the central portions of Georges Bank.' Recent analyses of genetic and natural marker data support such a boundary but small

sample sizes have been unable to identify a specific geographic break (Chapters 4, 6). Connectivity of early life stages do not suggest dispersal of larvae between inshore and offshore areas (Fig. 9.6) and fish tagged in the central portion of the bank tended to move east and only rarely crossed the Great South Channel to the west (Fig. 9.7b).

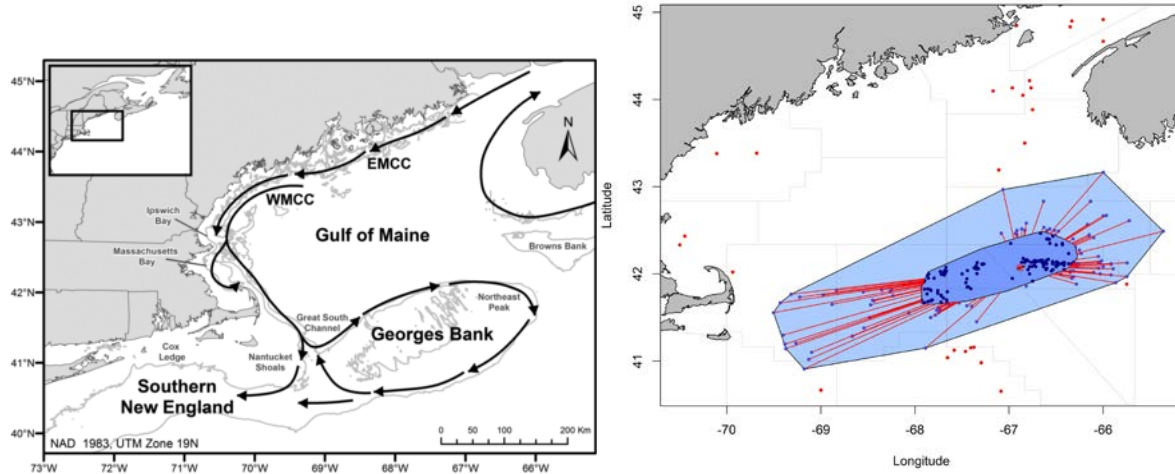


Figure 9.7. (a) Oceanographic delineation of Georges Bank as an anticyclonic gyre from the Great South Channel to the Northeast Peak (From Zemeckis et al. 2014; need permission); (b) A bagplot of 311 cod recaptures from fish released in stat area 522 and 525 from 2001 to 2006 in the months of December, February, March, April, and May (data source: Northeast Regional Cod Tagging Program, G. DeCelles). The bagplot depicts the median recapture position (red asterisk), area with 50% of recaptures (dark blue), approximately 95% of recaptures (light blue) and outliers (red dots).

Splitting cod in the Georges Bank management unit into two units, in an inshore-offshore manner, accounts for some but not all of the biological differences evident. The western portion of the Georges Bank management unit, statistical areas 537-9, is genetically distinct from the rest of this unit (Chapter 4, Fig. 9.3). In addition, in the central part of this management unit, there is considerable evidence that cod in area 521 are more aligned with the Gulf of Maine winter spawners than with cod offshore of southern New England or on Georges Bank (Chapters 3, 4, 5, Fig. 9.6). Recognizing all this evidence leads to splitting the current Georges Bank management unit into three biological stocks: eastern Georges Bank, southern New England, and areas 521 and 526, the latter of which are components of the Gulf of Maine stock (Fig. 9.8).

In the current Gulf of Maine management unit, additional biological structure is evident inshore, where spring and winter spawning groups overlap in areas 513-514. This results in sympatric spawning groups that are caught by the fishery as mixed compositions in these areas, including 515 (Dean et al. 2019).

The stock identity of cod from the northern Gulf of Maine statistical areas, for which there is little information to evaluate directly, is still uncertain. Historical evidence exists for latitudinal trends in natural markers among inshore areas (e.g., Sherman and Wise 1961, Chapter 6) and



limited movements of tagged fish in the northern Gulf of Maine (Chapter 7). These reports suggest that these fish were reproductively isolated from fish elsewhere in the Gulf of Maine. This has become a stubborn problem to resolve genetically because there are no spawning fish at present in recent decades, but Ames (1997) notes that both winter and spring spawning occurred there in the past.

## Consensus structure

The ACSSWG proposes a biological stock structure that includes both an inshore-offshore separation, as well as multiple inshore stocks, including a mixed-stock composition of spring and winter spawners in multiple statistical areas (Fig. 9.8).

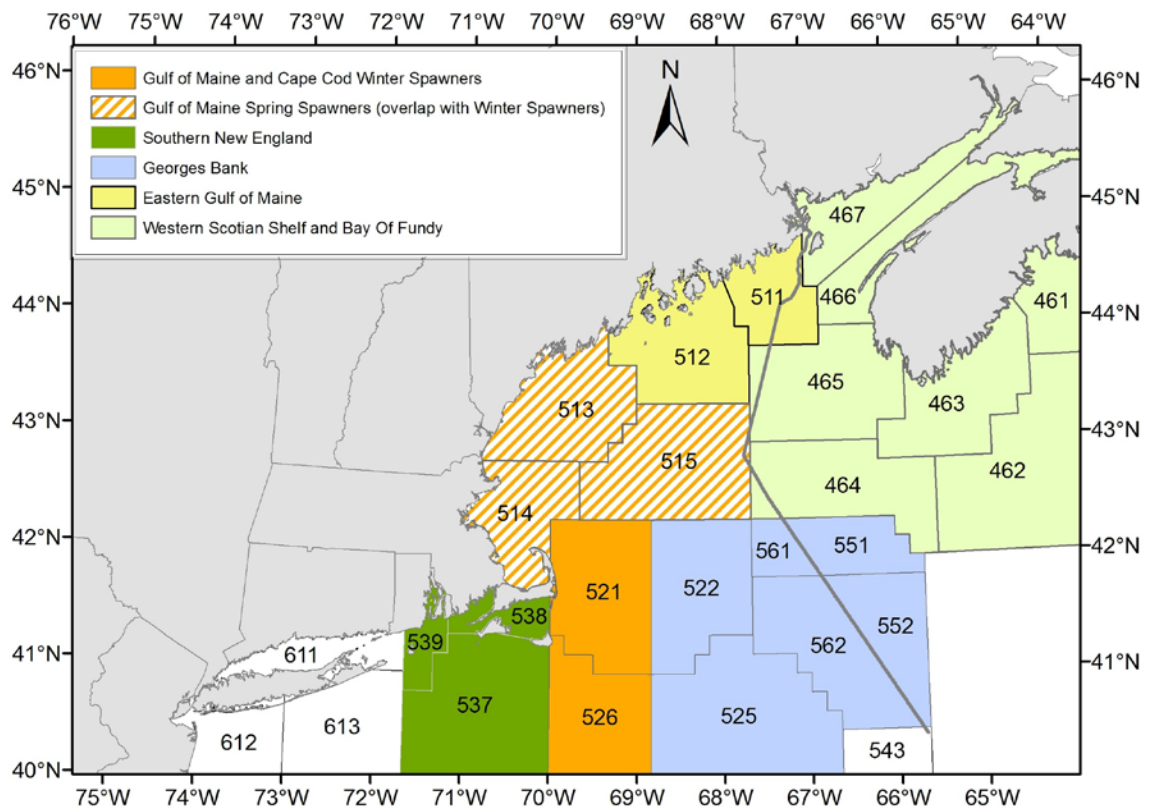


Figure 9.8. Proposed biological stock structure of cod in NAFO division 5 and adjacent division 4X.

1. A Georges Bank stock. This unit – an aggregate of areas 522, 525, 551, 552, 561, and 562 – includes what is already recognized and assessed by the Transboundary Resource Assessment Committee (i.e., 551, 552, 561, and 562) and areas 522 and 525. Discussed above is uncertainty about this offshore boundary, between 69° and 68° W, but the

available evidence supports fully including both 522 and 525 in this stock unit, which sets this boundary in accordance with existing fishing statistical areas (Fig. 9.1).

2. A southern New England stock. This unit – an aggregate of areas 537-9 – is recognized from genetic data showing differentiation in both neutral and adaptive markers, including genes associated with thermal tolerance (Fig. 9.3), localized movements of tagged fish (Fig. 9.4), and simulations suggesting that settlement would be localized (Fig. 9.6). Tag returns dating to the early 1900s indicated extensive seasonal connectivity between Nantucket Shoals (521) and part of the middle Atlantic seaboard, while tag returns since the 1980s suggest much less connectivity of SNE with 521; paired together, these findings support a decision to aggregate cod catches from statistical areas numbered in the 600s with catches in this stock area.
3. A western Gulf of Maine and Cape Cod winter spawner stock. This unit – an aggregate of areas 513-5, 521, and 526 – is recognized by considerable evidence of spawning in the western Gulf of Maine (Chapters 3, 7), historical spawning on Nantucket Shoals and in the Great South Channel (Chapter 8), as well as connectivity between these areas by dispersal of winter-spawned eggs and larvae (Fig. 9.6), genetic similarity (Fig. 9.3), and localized movements by adults (Fig. 9.4). This stock mixes with stock #4 in the western Gulf of Maine. Cod in 526 are assumed to be in this stock by proximity.
4. A western Gulf of Maine, spring spawner stock. This unit – an aggregate of areas 513-515 – is recognized by considerable evidence of spawning in the western Gulf of Maine (Chapters 3, 7) as well as localized tagging movements. This stock mixes with stock #3. It predominates in southern part of 513 and western 514, with any spawning north of that area is rare. In terms of adaptive genetic differentiation, this stock is the most distinct from other genetically-defined stocks. Cod in 515 are assumed to be in this stock by proximity.
5. An eastern Gulf of Maine stock. The stock affiliation of this area – an aggregate of areas 511-2 – is uncertain but likely an additional biological stock. Ames (1997) suggested that both winter and spring spawning occurred here, but genetic analyses have been unable to resolve the affinity of these cod because of a lack of spawning adults in either historical or recent collections. The lack of spawning adults stands in stark contrast to the active spawning occurs in the southwestern Gulf (areas 513-4), and it reflects the depleted state of cod in this area, suggesting source-sink dynamics between the eastern Gulf cod and neighboring regions that have yet to be revealed. Even when spawning was evident in the past, Ames (2004) suggested that cod in this area were reproductively isolated from the southwestern Gulf group. Limited tagging data here suggests greater movements from the

eastern Gulf (e.g., Downeast Maine) towards Canada, on the western Scotian Shelf, than towards the southwestern Gulf of Maine (Chapter 7).

6. Canadian stocks of 4X. This unit is assessed and managed by Canada and includes the Bay of Fundy and western Scotian Shelf regions (areas 461-67). Discreteness and connectivity of US and Canadian cod are supported largely by genetic data (Chapter 4; Fig. 9.3). Also, tagging data identify important routes of adults movement between Bay of Fundy and western Scotian Shelf component with a mixing area in Browns Bank, a strong connection between Browns Bank and Eastern Georges Bank, and some connectivity with eastern Gulf of Maine.

Using the reference criteria defined at the beginning of this chapter, we reject the existing management units, and some modest variations on this, as accurately reflecting the biological stock structure of cod. Major issues were:

1. numerous instances of both phenotypic and genetic variability indicating that cod are not well mixed within each management unit,
2. adult cod in some areas exhibiting extensive movements, including swimming between current US-US and US-Canada management units,
3. dispersal of cod larvae around Cape Cod from the western part of the Gulf of Maine management unit to the central-western part of the Georges Bank management unit, and
4. recognition of mix-stock fisheries arising from interdisciplinary evidence of sympatric winter- and spring-spawning cod in the southwestern Gulf of Maine and around Cape Cod.

This led to a consensus proposal that expands the number of biological cod stocks from two to five in US waters (NAFO Division 5). Inferences by the working group members is, however, based on a diminished biological resource, in terms of the historical biomass and productivity of cod. A review with a similar breadth of information, using different stock conditions, may have reached different conclusions about stock structure. As such, the working group recommends continued evaluations, for example, if extirpated spawning grounds become recolonized in downeast Maine or Nantucket Shoals, or if there are broadly-based changes in productivity to the region that affect cod.

## References Cited

Ames EP. 1997. Cod and haddock spawning grounds in the Gulf of Maine: From Grand Manan Channel to Ipswich Bay. Island Institute, Rockland, ME. Available at: <https://coastalfisheriesorg/wp-content/uploads/2017/03/Cod-and-Haddock-Spawning-Grounds-in-the-Gulf-of-Maine1pdf>.



Ames EP. 2004. Atlantic cod stock structure in the Gulf of Maine. *Fisheries*. 29(1):10-28.

Berg PR, Star B, Pampoulie C, Sodeland M, Barth JMI. 2016. Three chromosomal rearrangements promote genomic divergence between migratory and stationary ecotypes of Atlantic cod. *Sci Rep*. 6.

Dean M, Elzey S, Hoffman W, Buchan N, Grabowski JH. 2019. The relative importance of sub-populations to the Gulf of Maine stock of Atlantic cod. *ICES J Mar Sci*.doi: 10.1093/icesjms/fsz1083.

DFO (Department of Fisheries and Oceans, Canada). 2018. Stock assessment of Northern cod (NAFO Divisions 2J3KL) in 2018. DFO Can Sci Advis Sec Sci Advis Rep 2018/038.

Pampoulie C, Ruzzante DE, Chosson V, Jörundsdóttir TD, Taylor L, Thorsteinsson V, Daníelsdóttir AK, Marteinsdóttir G. 2006. The genetic structure of Atlantic cod (*Gadus morhua*) around Iceland: insight from microsatellites, the Pan I locus, and tagging experiments. *Can J Fish Aquat Sci*. 63(12):2660-2674.

Sherman K, Wise JP. 1961. Incidence of the cod parasite *Lernaeocera branchialis* L. in the New England area, and its possible use as an indicator of cod populations. *Limnol Oceanog*. 6(1):61-67.

Smedbol RK, Stephenson R. 2001. The importance of managing within-species diversity in cod and herring fisheries of the north-western Atlantic. *J Fish Biol*. 59:109-128.

Wise JP. 1963. Cod groups in the New England area. *Fish Bull*. 63(1):189-203.

Zemeckis DR, Martins D, Kerr LA, Cadrin SX. 2014. Stock identification of Atlantic cod (*Gadus morhua*) in US waters: an interdisciplinary approach. *ICES J Mar Sci*. 71(6):1490-1506.

## Acknowledgments

The ACSSWG is grateful to the many hands that helped assemble this review, as well as the commercial and recreational fishermen, regional scientists, and other interested parties that attended three outreach events to provide their ecological knowledge and feedback to inform the WG's deliberations. The New England Fishery Management Council and New Hampshire Sea Grant organized two symposia (<https://seagrant.unh.edu/cod-population-symposium>); in particular we thank Erik Chapman for sponsoring the symposia, Laura Taylor Singer for facilitating the meetings, Michelle Lemos for providing logistic support. The Maine Fishermen's Forum also hosted a seminar for the ACSSWG to present its findings; thanks to Maggie Raymond for hosting, to Ted Ames, Russ Brown, Steve Cadrin, Lisa Brown, and Tom Nies for serving on the panel. The working group members would like to thank their respective institutions for supporting their engagement on this topic, and specifically the New England

Fishery Management Council, who provided travel support to several members and symposium participants for attending meetings. The Research & Communications Branch at the Northeast Fisheries Science Center produced and maintained our webpage ([https://www.nefsc.noaa.gov/press\\_release/pr2018/other/cod-stock-structure/](https://www.nefsc.noaa.gov/press_release/pr2018/other/cod-stock-structure/)). We also appreciate the assistance of Mike Palmer (NEFSC), who was an initial member of the working group, as well as the numerous chapter reviewers, both internal and external to the working group, all who provided valuable input and guidance.

## Appendix A

### *Working group members and affiliations*

|                             |   |
|-----------------------------|---|
| Ames, Ted                   | Bowdoin College & MCCF Founding Board   |
| Andrushchenko, Irene        | Canadian Department of Fisheries & Oceans                                     |
| Cadrin, Steve               | University of Massachusetts Dartmouth, School for Marine Science & Technology |
| Cournane, Jamie             | New England Fishery Management Council  |
| Dean, Micah                 | Massachusetts Division of Marine Fisheries                                    |
| DeCelles, Greg              | Massachusetts Division of Marine Fisheries                                    |
| Kerr, Lisa                  | Gulf of Maine Research Institute  |
| Kovach, Adrienne            | University of New Hampshire   |
| *McBride, Rich              | NOAA Fisheries, Northeast Fisheries Science Center                            |
| Therkildsen, Nina Overgaard | Cornell University  |
| Puncher, Greg               | University of New Brunswick, Fisheries and Oceans Canada                      |
| *Smedbol, Kent              | Canadian Department of Fisheries & Oceans                                     |
| Wang, Yanjun                | Canadian Department of Fisheries & Oceans                                     |
| Zemeckis, Doug              | Rutgers University  |

\*co-chairs

## **Appendix B**

### *Atlantic Cod Stock Structure Working Group, Terms of Reference (May 14, 2018)*

1. Inventory and summarize all relevant peer-review information about stock structure of Atlantic cod in NAFO Divs. 5 and 6 and interactions with 4X. Evaluate the relative importance of the information with respect to developing a holistic understanding of Atlantic cod stock structure.
2. Identify and evaluate any new or existing data or information about the stock structure of Atlantic cod in NAFO Divs. 5 and 6 and interactions with 4X, and subject to a peer-review by the working group. Integrate any additional information into the inventory developed in TOR 1.
3. Using a holistic approach, synthesize all available information (TOR 1 and 2) and develop sets of possible biological stock structures and consider scientific support for each alternative. In developing alternative stock structures, consider the temporal stability of stock structure and how the available information can inform the knowledge of stock structure over time.
4. Evaluate the historical and contemporary fisheries-dependent and -independent data collection programs and evaluate current modeling techniques relative to the alternatives developed in TOR3. Summarize the practical limitations for each alternative.
5. Broadly consider potential management procedures to meet management objectives including but not limited to maintaining status quo, altering stock boundaries, spatial and temporal restrictions, and stock composition analyses
6. Identify any major information gaps in the existing research with respect to cod stock structure. Develop a prioritized list of research recommendations to address these gaps. Comment on the feasibility and time horizon (e.g., short-term, long-term) of the proposed research recommendations.
7. Identify any major data collection and modeling gaps that limit the use of stock structure alternatives.

This document only addresses TORs 1-3; TORs 4-7 will be addressed as a separate process.

## **Appendix C**

### *Atlantic Cod Stock Structure Work Group, Objectives (May 14, 2018)*

Determine the most appropriate representation of Atlantic Cod stock structure for use in regional stock assessments (NAFO Divisions 5 and 6 and interactions with 4X) based on currently available information. “Most appropriate” means having the greatest scientific support and accurately capturing the available data and assessment model frameworks. This determination will not include the running of assessment models.

Identify high priority research that would contribute significantly to the issue of cod stock structure.

Broadly consider potential management actions to meet management objectives including but not limited to maintaining status quo, altering stock boundaries, spatial and temporal restrictions, and stock composition analyses.

The following are explicitly not part of this Working Group: New benchmark assessment, reference determination, and quota setting.

Follow a transparent process by including stakeholders in public meetings and through regular updates.

## Appendix D

### *Glossary (listing terms now, need to define)*

Include genetic terms from AK et al.

A50, Median age at maturity. A specific point for age at maturity, the point where a fish at that age has a 50% probability of being immature or mature.

L50, Median length at maturity

Annulus

Applied marker

Connectivity

Cyclonic

Early life history

Electronic tag

Extirpation

Fishermen's Ecological knowledge

Genetic marker

Genotype

Hague line

Heterogeneous

Holistic approach

Interdisciplinary approach

Life history

Meristics

Natural marker

NAFO Division

Phenotype

Population

Recruitment

Settlement

Stock, biological

Stock, fishery

Stock, mixed-

Stock, unit

Management unit

Serological

Spawning aggregation (this is the genetic list)

Statistical area

Sympatric

Transboundary

metapopulation? was this used?

### *Acronyms and abbreviations*

ACSSWG: [Atlantic Cod Stock Structure Working Group](#)

NAFO: [North Atlantic Fishery Organization](#)

NEFMC: [New England Fishery Management Council](#)

SSC: [Scientific and Statistical Committee](#)

TRAC: [Transboundary Resources Assessment Committee](#)

TMGC: [Transboundary Management Guidance Committee](#)