

Item No. _____

Quantity _____



BEVERAGE-AIR

Commercial Refrigeration Equipment General Specifications

SCHOOL MILK COOLERS SMF SERIES FORCED AIR

**MODELS:
SMF34
SMF49
SMF58**

Forced air milk coolers are designed to keep milk cold during prolonged serving periods in excess of 2 hours. Covered under U.S. patent #4,972,682, a continuous cold-air blanket over the milk cartons keeps the milk cold and drinkable (under 38°) during serving.

SMF models are available in single access only because of the use of overhead, perforated plenum in the design of a laminar flow, cold airdrop. Standard construction includes the lid, door, adjustable hinges, and door latches made from stainless steel. Interior is galvanized steel. Floors are heavily reinforced. Heavy duty, epoxy coated steel wire floor racks are provided for added floor protection.

Digital thermometer is standard. Cylinder lock, bottom drain, and swivel casters (2 with locks) are standard. Insulation is two inches thick foamed-in-place polyurethane, CFC free for compliance to environmental concerns. This insulation further strengthens overall construction and is impervious to liquid penetration and resulting foul odor. Overall depth of 31 1/2 inches allow easy mobility and clear passage through most doorways.

Models are also offered as standard with stainless steel exterior in place of white finish on steel. A stainless steel interior is optionally available. Additional options include wrap around and corner bumpers.

Refrigerant used is 404A, which is CFC free for full compliance to all environmental concerns. Service cord is provided at rear of cabinet for electrical plug in.



Made in USA
<http://www.Beverage-Air.com>
<http://CCR.Carrier.com>



PO Box 5932, Spartanburg, SC 29304
1-800-845-9800 Fax No. 1-864-582-5083

Model Specified _____ Store# _____

Location _____ Quantity _____



BEVERAGE-AIR

School Milk Coolers SMF Series Forced Air

Models: SMF34 / SMF49 / SMF58

MODEL	SMF34	SMF49	SMF58
DIMENSIONAL DATA			
Net Capacity (cubic ft.)	14	20.5	24.8
Net Capacity (liters)	396	580	702
Width (inches)	34"	49"	58"
Width (mm)	863	1244	1473
Depth (inches)	33 1/2"	33 1/2"	33 1/2"
Depth (mm)	851	851	851
Height (inches)	47"	47"	47"
Height (mm)	1193	1193	1193
Doors/Lids	Single Access	Single Access	Single Access
CASE CAPACITIES			
13" x 13" x 11"	8	12	16
19" x 13" x 11"	4	8	10
ELECTRICAL DATA			
Volts	115	115	115
Amps	7.4	8.2	8.2
REFRIG. DATA			
Refrigerant	404A	404A	404A
Horsepower	1/3	1/2	1/2
WEIGHT DATA			
Gross Weight (Crated lbs)	320	407	453
Gross Weight (Crated kg)	145	184	205

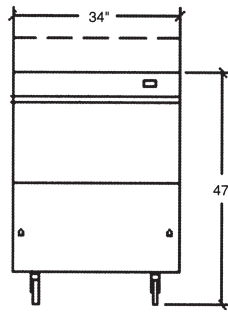

SMF34 Front

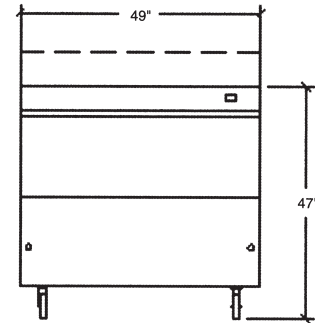

SMF49 Front

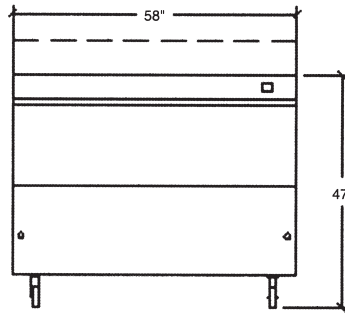

SMF58 Front

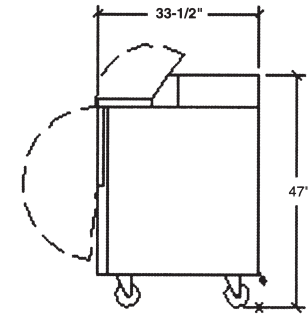

SMF34, 49, 58 Common End



Available From:



BEVERAGE-AIR

PO Box 5932 • Spartanburg, SC • 29304 • USA
1-800-845-9800 • Fax No. 1-864-582-5083
www.Beverage-Air.com