



## JH CISAA Basketball Championships Tier 2 & Tier 3 Grade Seven Boys



February 28th, March 1st, March 2nd, March 3rd

		<u>Location</u>	<u>Team 1</u>	<u>Team 2</u>
F28	Wed 3:15PM	A1 CA	FFCA	FA
F28	Wed 12:30PM	A2 CA	CA	CFIS
M1	Thu 5:15PM	A3 WA	WA	MAC
M1	Thu 4:15PM	A4 WA	CWS	CWA
M2	Fri: 12:15AM	B1 CA	Loss A1	Loss A2
M2	Fri 2:45 PM	B2 CA	Loss A3	Loss A4
M2	Fri: 4:15PM	A5 WA	Winn A1	Winn A2
M2	Fri 5:15 PM	A6 WA	Winn A3	Winn A4
M3	Sat 9AM	B3 CA	Loss B1	Loss B2
M3	Sat 10AM	B4 CA	Win B1	Win B2
M3	11:30AM	A7 CA	Loss A5	Loss A6
M3	12:30PM	A8 CA	Win A5	Win A6

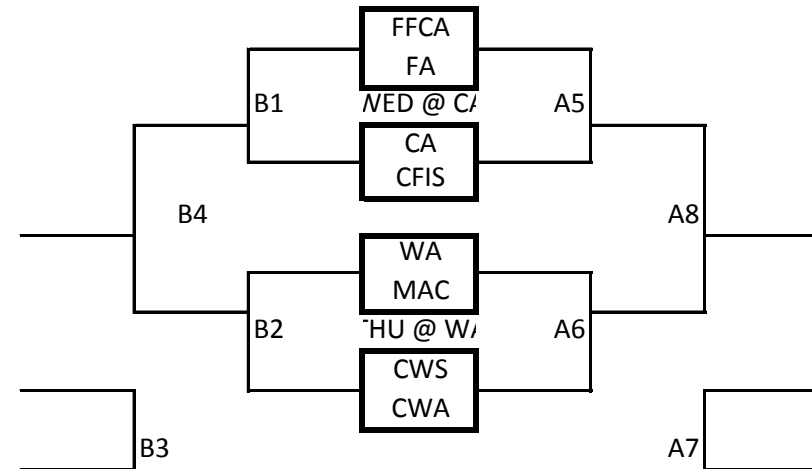

### RULES/ GUIDELINES

- x. FIBA Rules – 4 x 10 minute run time, last minute of each quarter is stop time. 5 minute HALF time break.
- xi. Bonus (Penalty) – 2 shot penalty will occur on the 4th foul of each quarter
- xii. Always handle in the backcourt (except after basket)
- xiii. 8 Second continuous to cross half court
- xiv. Zone defences are prohibited - "
- Help defense is allowed when a defender has lost their man and the player shows intent to drive to the basket.
- no zone defense
- no full court press
- xv. Full court defences are prohibited
- xvi. Overtime – 1 1 period of 3 minute running time (last minute stop time). All 4th quarter violations, timeouts, etc carry over in to the overtime period. Start the overtime with a jump ball, not possession arrow. After time expires in the overtime period play continues with NO CLOCK. The very next successful basket (including free throws) wins the match. We shouldn't have games that end in a tie.
- xvii. Time Outs are called through the scorekeepers table. Time is STOPPED during time outs (hence the name Time OUT).