



INSTRUCTION MANUAL

Circulating Water Temperature Control System

**Models Covered:
Duratherm, Hydrotherm II, & Minitherm**

2150 Elmwood Avenue - Buffalo, NY 14207
P# 716-876-9951 - F#716-874-8048 - www.mokon.com

Table of Contents

Section 1 – Warnings and Cautions	1
1.1 Electrical Warning	1
1.2 Hot Fluid Warning	1
1.3 Cold Weather Caution.....	1
1.4 Excessive Supply Pressure Caution	1
Model: DN, DO, DP, DQ, DR, DT, DU, DV, DW, DX, DY, DZ, HN, HR, HW, HX, HY, HZ, MT	1
1.5 Excessive Supply Pressure Caution	2
Models: DA, DB, DC, DD, DE, DF, DG, DH, DJ, DK, DL, DM.....	2
1.6 Overhead Piping Warning.....	2
1.7 Short Circuit Current Rating Caution	2
1.8 No Flow Warning	2
1.9 Non-Potable Water System.....	2
Section 2 – Installation	3
2.1 Unpacking.....	3
2.2 Location	3
2.3 Warnings.....	4
2.4 Electrical Connections	4
2.5 Water Connections.....	5
Section 3 – Operation	6
3.1 Initial Starting Procedure	6
3.2 Process Flow Adjustment	6
3.3 Changing Temperature Settings.....	7
3.4 Shut Down Procedure	7
3.5 Restarting Procedure.....	7
Section 4 – Maintenance and Service.....	8
4.1 Preventative Maintenance	8
Electrical Preventative Maintenance	9
Pump/Motor and Mechanical Connections Preventative Maintenance.....	10
Miscellaneous Preventative Maintenance.....	11
4.2 Pump Maintenance.....	13
Models: DN, DO, DR, DT, DU, DW, DY, DZ, HN, HR, HW, HX, HY, HZ	13
Exploded View Drawing Models: DN, DO, DR, DT, DU, DW, DY, DZ	13
Exploded View Drawing Models: HN, HR, HW, HX, HY, HZ.....	14
Seal Replacement/Maintenance	15
Models: DP, DQ, DV, DX.....	17
Exploded View Drawing.....	17
Seal Replacement/Maintenance	18
Models: DB, DC, DF, DG, DJ, DL	20
Exploded View Drawing.....	20
Seal Replacement/Maintenance	21

Mounting the Motor to the Pump.....	22
Impeller Removal.....	23
Inspection.....	23
Impeller Clearance Adjustment	23
Models: DA, DD, DE, DH, DK, DM	24
Exploded View Drawing.....	24
Seal Replacement/Maintenance	25
Model: MT.....	27
Exploded View Drawing.....	27
Seal Replacement/Maintenance	28
4.3 Cooling Solenoid Valve Maintenance	30
4.4 Low Pressure Safety Switch	30
4.5 High Temperature Safety Switch.....	30
4.6 Heater Assembly.....	31
Models: DA, DB, DC, DD, DE, DF, DG, DH, DJ, DK, DL, DM, DN, DO, DP, DQ, DR, DT, DU, DV, DW, DX, DY, DZ	31
4.7 Heater Element Wiring	33
Models: HN, HR, HW, HX, HY, HZ, MT	33
Section 5 – Eurotherm Controller (3000 Series)	34
5.1 Operation.....	34
Home List Navigation.....	34
Keys	35
5.2 Automatic Tuning.....	35
5.3 Troubleshooting	37
5.4 Alarm Indicators	37
To Acknowledge an Alarm.....	37
5.6 Restarting the Automatic Air Purge Timer (After Start-Up).....	39
5.7 Manual Air Purge Operation (After Start-Up).....	39
5.8 Remote Set Point and Retransmission “Scaling”.....	39
Section 6 – Options	40
6.1 Pressure Regulator	40
Exploded View Drawing	40
Maintenance Instructions.....	40
Adjustment.....	40
6.2 Instruction for Initial Start-Up of Non-Pressurized Supply Tank.....	41
6.3 Instructions for Initial Start-Up of Pressurized Supply Tank	41
6.4 System “Z” Purge Instructions for All Systems	42
6.5 NPS Option	43
Water Connections.....	43
Unit Operation	43
Initial Starting Procedure	43
Adjusting the Vacuum	44
6.6 Operation of Automatic Process (Mold) Purge	44
6.7 Cool Down and Automatic Shut Off	45
Adjusting Auto Cool Down/Shutdown Timer.....	45
6.8 Emergency Stop.....	45
6.9 Valved Process Bypass	45

Section 7 – Troubleshooting Guide	46
Section 8 – Condensed Parts List	49
8.1 All Models:	49
8.2 Duratherm Models:	49
8.3 Minitherm Models:	50
8.4 Hydrotherm II Models:	50
Section 9 – Warranty	51
End of Life Industrial Waste - Saving our Environment	52

Water Systems

Quick Start-Up Checklist

Please verify that the product received matches the product ordered and that the equipment is designed for the intended application. The following quick checklist is an abridged version - always refer to the Mokon Manual provided for additional data and requirements prior to the commissioning of the unit.

✓ **Electrical Inspection**

- ❑ Verify amp draws and voltage on serial tag match electrical service being supplied.
- ❑ All electrical termination points checked for tightness.
- ❑ Electrical wiring completed and disconnect sized and installed per code and compliance.
- ❑ Motor rotation verified, motor(s) bumped.
- ❑ Verify any remote control wiring is complete.

✓ **Mechanical Inspection**

- ❑ Mechanical fittings tight.
- ❑ Unions tight.
- ❑ Compression fittings tight.
- ❑ Insure Supply, Drain and Process connections are connected properly and operating pressure does not exceed ratings.

✓ **Location and Good Standard Installation Practices**

- ❑ Confirm safe access to equipment for maintenance, removal and lockout- tag out.
- ❑ Insure equipment is designed for the installed environment.
- ❑ Allow a minimum of 4 feet (1.2 meters) on all four (4) sides to allow for proper maintenance and operation.
- ❑ Allow a minimum of 4 feet (1.2 meters) or more above unit for proper ventilation. Please use extreme caution when dealing with hot surfaces.



Section 1 – Warnings and Cautions

Please read and understand this section before operating the system!

1.1 Electrical Warning



The Mokon temperature control system, as with all high voltage electrical equipment, should be connected according to all local and national codes. All installation, maintenance, service, repair, adjustment, and operation should be done only by qualified trained electrical personnel who have read and completely understood this instruction manual. To the upper right is a symbol for Electrical Danger. When it is seen on the following pages of this manual as well as on the system, care should be taken to avoid possible electric shock. All maintenance and service should be performed with the power isolated and locked out except where noted.

1.2 Hot Fluid Warning



Exercise Extreme Caution while working on or in the area of the Mokon temperature control system. The high temperature of the fluid will cause the process lines, the system components, and the metal cabinetry to become very hot and therefore should not be touched. To the upper right is a symbol for surface may be hot, high temperature. When it is seen on the following pages of this manual, care should be taken to avoid possible burns. All maintenance and service must be performed with the system completely cooled. It is advisable to plug the process ports of any unused zones so that if a wrong button is pressed, fluid will not be pumped through them.

1.3 Cold Weather Caution



If the Mokon temperature control system will be moved from your plant and will be subjected to freezing temperatures, the water in the system must be completely drained and/or sufficient antifreeze added to prevent serious water damage from freezing.

1.4 Excessive Supply Pressure Caution

Model: DN, DO, DP, DQ, DR, DT, DU, DV, DW, DX, DY, DZ, HN, HR, HW, HX, HY, HZ, MT

Mokon suggests an optional pressure regulator on Mokon temperature control systems for applications with high supply water pressure (exceeding 50 PSI, 345 kPa) to reduce or eliminate the potential for water hammer. Recommended pressure is 30 PSI (207 kPa). Water hammer in the Mokon temperature control system or the process and cooling lines can lead to system damage and reduced system life. If a pressure regulator is added to the Mokon temperature control system, it must be of the design that incorporates a bleed off for thermal expansion of the fluid.

1.5 Excessive Supply Pressure Caution

Models: DA, DB, DC, DD, DE, DF, DG, DH, DJ, DK, DL, DM

A water supply of 60 PSI (414 kPa) is required to operate these systems at 300°F (149°C). Mokon suggests an optional pressure regulator on Mokon temperature control systems for applications with high supply water pressure (exceeding 75 PSI/ 517 kPa) to reduce or eliminate the potential for water hammer. Water hammer in the Mokon temperature control system or the process and cooling lines can lead to system damage and reduced system life. If a pressure regulator is added to the Mokon temperature control system, it must be of the design that incorporates a bleed off for thermal expansion of the fluid.

1.6 Overhead Piping Warning

When overhead piping is connected to a Mokon temperature control system equipped with an open reservoir or non-pressurized expansion tank there is risk of overflow of the system's reservoir tank upon shutdown, this is due to the back flow of fluid volume from the overhead piping system.

To prevent reservoir tank overflow an overhead piping kit should be installed. This kit is available from Mokon as an option.

1.7 Short Circuit Current Rating Caution

Equipment supplied with a safety door disconnect or power cord is design rated for a short circuit current rating (SCCR) of 10,000 amperes RMS if protected with a class "J" fuse.

1.8 No Flow Warning

It should be noted that if any external valves are installed in the process flow path, they must be opened before starting the Mokon temperature control system or risk causing serious damage to the system and the process.

Fluid must be established (flowing) through the Mokon temperature control system in order for the safety features to work properly and adequately protect the Mokon temperature control system.

The use of valves downstream of the Mokon temperature control system are not recommended as they could potentially render the system safeties inoperative if closed. This could cause serious system damage and would void the warranty. To avoid disabling the standard safety features, please contact Mokon to discuss optional safety features that may be required to adequately protect the assembly.

1.9 Non-Potable Water System

This system has been designed for use in non-potable water applications only. For applications requiring potable water use please contact Mokon directly to discuss a product offering.

Section 2 – Installation

2.1 Unpacking

Upon arrival inspection should be done to assure there was no damage during shipping. In addition, all electrical and mechanical connections should be inspected to ensure that they are secure and tight. This includes all electrical terminations, mechanical fitting union bulbs, compression fittings, etc.

Note: Refer to Section 4.1 Maintenance and service.

The maximum weights of the Mokon water systems when drained of water are:

Duratherm - 475 lbs (160 kg)

Dual Zone Duratherm - 950 lbs (232 kg)

Hydrotherm II - 175 lbs (80 kg)

Minitherm - 110 lbs (50 kg)

Properly rated equipment should be used to move this machinery.

When removing system from pallet, lift from bottom only. Care should be taken to ensure that the system will not tip. After removing from pallet, the system should only be placed on a level surface.

2.2 Location

Mokon systems should be located in an area that provides adequate space for pedestrian and vehicle traffic. If this is not feasible, owner should provide additional safeguards including safety signs.

For optimum system performance, allow adequate space and ventilation around entire system, as well as a means to direct vapors away from work area.

There should be a minimum of four (4) feet of clearance around the entire Mokon system (all sides) for adequate ventilation and operation of the system.

If braking casters are included, they must be in the locked position when system is in the operating position. Prior to moving, unlock the casters.

Customer supplied and installed air vents (mechanical or electrical) should be placed at the highest point in the process for application where the process height is greater than eight (8) feet above Mokon system.

2.3 Warnings

Owner should ensure by adequate supervision that correct safety, installation, maintenance and operating procedures described in this manual, as well as recognized industry practice, are followed by all personnel.

All panels must be in place during normal operation.

The top of the machinery should not be used for storage.

Power sources or energy types referred to in this manual are water and electricity.

This machinery is not for use in hazardous or explosion proof environments.

Under normal operating conditions, the decibel level of the machinery is 67 db or lower.

Any alteration, additions or modifications to any part of the system must receive prior written approval from Mokon's Engineering or Customer Service Departments.

Refer to serial tag for motor and heater electrical information and schematic drawing number.

2.4 Electrical Connections



Warning: The Mokon temperature control system, as with all high voltage electrical equipment, should be connected according to all applicable state and local codes. All installation, maintenance, service, repair, adjustment, and operation should be done only by qualified trained electrical personnel who have read and completely understood this instruction manual.

Before operating the Mokon temperature control system, the grounding wire must be connected. The grounding wire is the green or green and yellow wire connected to the frame of the system.

Connect ground wire to the ground screw (labeled PE or GND) located in the electrical box. Connect power lines L1, L2, L3, to disconnect switch or terminal blocks marked L1, L2, and L3 respectively, inside the electrical box. Overcurrent protection of the supply conductors should be sized according to The National Electrical Code (NEC) and any other applicable state and local codes.

2.5 Water Connections



Exercise extreme caution while working on or in the area of the Mokon temperature control system. The high temperature of the fluid will cause the process lines, the system components, and the metal cabinetry to become very hot and therefore, they should not be touched.

There are four (4) convenient and clearly marked connections, "Supply Water," "To Process," "From Process" and "Drain Water."

Note: It is not recommended that quick disconnects be used on any of the connections, as they will restrict the flow.)

Caution: The "Supply Water" fluid connection must not be valved in any way. If you add or replace a pressure regulator to a Mokon temperature control system it must be of the design that incorporates a bleed off for thermal expansion of the fluid. This style of regulator is available from Mokon. During a heating cycle, thermal expansion is created and is bled off through the supply. If the supply source is valved or restricted in any way, this will cause the Mokon temperature control system to lose it's capabilities of bleeding off for thermal expansion, and can damage the system. Consult the Mokon factory for recommendations.

Supply Water: Connect this port to an adequate source of cold, clean supply water. Do not restrict incoming water to the Mokon temperature control system for the reasons outlined above. The pressure regulator (if included on system as an option) is set at the factory for suitable operation of the Mokon temperature control. For systems with a pressure regulator, see Section 6.1 for adjustment procedures. For systems without a pressure regulator see Section 1.4 or 1.5 for recommended pressures.

To Process: Connect this port to the process inlet, through which temperature controlled water will enter the process. Use full size unrestricted high temperature hose or pipe rated for the proper pressure and temperature.

From Process: Connect this port to the process outlet, from which temperature controlled water will leave the process. Use full size unrestricted high temperature hose or pipe rated for the proper pressure and temperature.

Caution: The "Drain Water" connection must not be valved in any way. In plant recirculating systems return line pressure restrict the performance of open circuit type Mokon temperature control systems. If plant drainage systems are pressurized it can cause the Mokon temperature control system to reduce or lose its cooling capabilities. Consult the Mokon factory for recommendations.

Drain Water: Connect this port to drain (or return line in an in plant closed recirculation system).

Reservoir Filling: For Mokon temperature control systems with an optional fluid reservoir, the reservoir needs to be filled prior to operation. Fill to a minimum of 1/2 full with a water or water/glycol mixture.

Section 3 – Operation

3.1 Initial Starting Procedure

- Turn on the water supply connected to the Mokon temperature control system. (See Section 2.5 for water connections)
- Turn on the electrical main disconnect switch. (See Section 2.4 for electrical connections)
- If provided, turn on the electrical box door disconnect switch.
- For each zone, check the motor rotation by turning on the system momentarily (press the “Start” button then the “Stop” button). As the pump slows down, check the motor rotation. If the motor is not rotating in the direction of the arrow label located on the motor housing (clockwise from the lead end), reverse any two power cord leads to change the direction of the motor rotation. (See Section 2.4)
- Restart the system and set the controller to the minimum temperature. (See Section 5 for controller instructions)
- Allow the system to run for several minutes with the controller set to the minimum temperature to remove air from the system. All systems have as standard an auto-air purge, factory default set for 5 minutes. After 5 minutes of operation at the minimum temperature the system should automatically purge itself of air. There is also a manual purge button that can be used on Duratherm and Minitherm systems for Hydrotherm II systems refer to Section 5.5 and 5.6 for additional air purge instructions.

Note: Some processes require a different air purge timed cycle other than the factory default set value. Adjustments can be made to either lengthen or shorten this timed cycle. Please refer to Sections 5.5 and 5.6 for additional information on the automatic air purge feature.

- Set the controller to the desired temperature. The system will reach the setpoint temperature. (See Section 5 for controller instructions)

Note: Automatic air purge, during start-up removes air from lines (add an air-bleed and/or air separator at highest process loop point if needed to help expel air from process).

3.2 Process Flow Adjustment

- The operator must determine and set proper water flow rate for the most efficient and trouble free operation.
 - Water flow rate through the process is determined by the pressure losses in the process loop. Generally, higher flow rates result in turbulent flow achieving maximum temperature control and lower maintenance.
 - If the flow rate exceeds the motor HP capacity, the electric motor will draw excessive amps. This is a result of the process loop’s ability to flow water at a greater rate than can be provided by the pump. This will eventually result in tripping the thermal motor overload relay (overload relays open and the unit will shut down)
- If an excessive flow situation is encountered and the motor overload circuit has tripped, the operator must manually reset the overload relay before operations can continue. This is done by opening the electrical panel cover, identifying the reset level of the overload relay, and pushing the reset level “in” until the overloads are reset.
- If a motor overload situation persists, the operator must adjust the flow rate to match the system pressure loss (reduce flow rate) to prevent continual tripping of the overload relay.

- Open electrical cabinet panel door.
Note: That the electrical power is engaged at this point and caution must be observed while the cabinet panel is open.
- Identify the motor starter block. This block consists of the motor starter contactor and the overload relay.
- Place an amp meter on a single power lead coming from the overload relay.
- Locate the motor name plate on the pump motor housing. The full load amp rating for the motor is listed on the name plate.



- Engage the electrical power supply and start the unit.
- The amp meter will display the motor amps. Compare the actual motor amps as displayed on the amp meter to the full load amp rating as listed on the motor name plate.
- If the amp draw is excessive (higher than the listed name plate amp rating), a throttling valve must be installed in the "from process" water line. The throttling valve can be a gate valve or a ball valve.
- With the throttling valve installed, fully close the valve and then engage the pump motor. Slowly open the throttling valve and monitor the motor amps as displayed on the amp meter until the actual motor amps equal the listed full load amp rating of the motor. The process flow is correctly adjusted. The valve should remain in this position during operation.

3.3 Changing Temperature Settings

If a new temperature setting is required while the system is in operation, adjust the controller to the new desired setpoint temperature. See Section 5 for controller instructions.

3.4 Shut Down Procedure

Cool the Mokon temperature control system down by reducing the setpoint temperature to 100°F (38°C) or lower. When the system is cooled, push the "Stop" button to shut off the system. *Do not shut the system off at elevated temperatures, this can be detrimental to system life.* The water and main electrical power to the Mokon temperature control system may be turned off if desired but is not necessary unless the system is being relocated or for prolonged shut down.

3.5 Restarting Procedure

- If the water lines and main electrical power have not been disconnected, refer to Section 3.1.
- If the water lines and/or the main electrical power have been disconnected, refer to Section 2.4 for Electrical Connections, Section 2.5 for Water Connections, and Section 3.1 for Initial Start-Up Procedure.

Section 4 – Maintenance and Service

Warning: The maintenance and service procedures included in Sections 4.1 – 4.11 require that all power sources to the Mokon temperature control system be shut off, isolated and locked out (exceptions noted) and that the system be completely cooled. Follow all local and national codes and procedures for working on electrical equipment. Failure to do so could result in injury or death. Only qualified electrical personnel should install, maintain, repair, adjust, and operate Mokon temperature control systems. The instruction manual furnished with the system should be completely read and understood before system maintenance.

The following hazard warning symbols will be used to denote a specific hazard associated with a procedure.

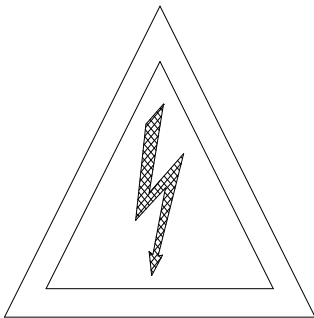

Electrical Danger

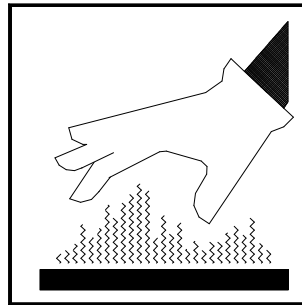

High Temperature
Surface May Be Hot

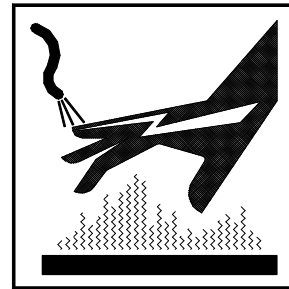

High Voltage &
Hot Surface

4.1 Preventative Maintenance



Mokon temperature control systems are designed for a long, trouble free service life under a variety of conditions, with a minimum of maintenance. Performing the following preventative procedures will extend the life of your system. Refer to Section 4.1 - 4.11 in the instruction manual for specific adjustment or service procedures. Refer to the condensed parts list included in Section 8 of the instruction manual for proper replacement parts if required.

The preventative maintenance section is broken into weekly, monthly, and every three months checks. Associated with each check is a series of corrective procedures that may solve a problem detected in the check. If the corrective procedures do not resolve a problem detected in the check, see the trouble shooting guide in Section 7 for a complete list of corrective measures.



Electrical Preventative Maintenance

Weekly Checks	Corrective Procedures
Check electrical box interior components for any discoloration, or any burn marks	Correct component wiring
	Verify voltage and frequency stamped on system matches customer supply voltage and frequency
	Correct excessive system load (current draw)
	Verify customer supply voltage is balanced and fluctuations are within 5% of nominal
	Verify wire gauge for main power hookup is properly sized
	Replace components if needed
Check for blown fuses	Replace with the correct size and style fuse
For units with solid state contactors, inspect the screen covering the fan inside the electrical enclosure	If clogged with debris, clean or replace the screen. If not cleaned or replaced excessive heat build-up can occur in the electrical enclosure reducing component life and wiring. System warranty will be void.
Monthly Checks	Corrective Procedures
Check that the high temperature switch (TS) has a set of N.O. and N.C. contacts, and it is properly wired	Replace the switch if necessary
Check that the low pressure switch (PS) has a set of N.O. and N.C. contacts, and it is properly wired	Replace the switch if necessary
Every 3 Months Checks	Corrective Procedures
Check that the interior electrical and mechanical components are securely fastened to the back panel, and/or to the sides of the electrical box	Tighten with proper tooling
Check that the ratings of overload protection (such as fuses and circuit breakers) adequately protect the line's maximum current carrying capacity	Inspect/replace fuses
	Inspect/replace motor starter overloads
Check the fuses against the electrical schematic for proper size according to the systems voltage	Replace if different
Slightly tug on each wire / conductor to make sure it makes a solid contact to its attached component. Pay close attention to the green grounding wires.	Tighten with proper tooling

Pump/Motor and Mechanical Connections Preventative Maintenance

Weekly Checks	Corrective Procedures
Check for foreign materials obstructing airflow in the motor and pump area	Remove all dust, lint, grease or oil with a cloth and/or brush
Check the motor rotation is correct by observing the direction of rotation through the grillwork on the motor (Power On then Off)	Reverse any two incoming power cord leads to correct rotation
Monthly Checks	Corrective Procedures
Check that all bolts and screws are securely tightened	Tighten with proper tooling
 Check for plumbing leaks	Repair solder joints
	Replace necessary parts if leaks persist
Visually check all threaded fittings for signs of leakage	Tighten with proper tooling
	Replace necessary parts if leaks persist
Check that the motor current draw matches the serial tag rating	Correct motor wiring Verify supply voltage is balanced and fluctuations are within 5% of nominal
 Check gauge readings on the cabinet (Power On)	Verify suction or discharged line not partially clogged
	Verify no restrictions in process or supply lines
	Replace gauge(s) if needed
Semi Annual Checks	Corrective Procedures
Check that all threaded fittings within the fluid loop are securely tightened	Tighten with proper tooling
	Replace necessary parts if leaks persist

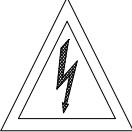
Miscellaneous Preventative Maintenance

Monthly Checks	Corrective Procedures
 <p>Check that all applicable lights, gauges, and optional indicators are functioning properly (Power On)</p>	<p>Replace necessary components</p>
 <p>Check the cooling solenoid operation by elevating setpoint temperature manually. While in the heating mode, push the manual air purge button. Listen for the cooling solenoid's audible energizing and de-energizing "clicking sound." Observe process temperature decreasing. (Power On)</p>	<p>Using a Voltmeter, determine if solenoid coil is energizing</p>
	<p>Replace solenoid valve, if necessary</p>
 <p>Check the controller calibration by setting the controller for three random setpoints within the operating range of the system. Observe that the process temperature output is within the accuracy of the controller. (Power On)</p>	<p>Calibrate controller using Section 5 in the instruction manual (Power On)</p>
	<p>Verify the thermocouple wires at controller are secure</p>
	<p>If controller does not respond to any of the above steps, consult the Mokon factory <u><i>Do not attempt repairs as the warranty could become void.</i></u></p>
 <p>Check the system for leaks at operating temperatures. As the system reaches the setpoint temperature, visually check for leaks.</p>	<p>Repair leaks and/or tighten fittings</p>
	<p>Replace necessary parts</p>

Monthly Checks	Corrective Procedures
Check that the heater current draw matches the serial tag rating	Verify heater wiring stake-on is secured
	Correct heater wiring
	Verify customer supply voltage is balanced and fluctuations are within 5% of nominal Replace elements if necessary
Check that the "Warning," "High Voltage," "Caution," and lamicoid labeling are adhering to the correct locations	Replace torn, damaged or missing labels
Check screen in optional pressure regulator for debris	Remove screen and clean

4.2 Pump Maintenance

Models: DN, DO, DR, DT, DU, DW, DY, DZ, HN, HR, HW, HX, HY, HZ

Exploded View Drawing Models: DN, DO, DR, DT, DU, DW, DY, DZ

REF. NO.	QTY.	DN 3 HP	DO 5 HP	DR 1.5 HP	DT ¾ HP	DU 5 HP	DW 3 HP	DY 1.5 HP	DZ ¾ HP	DESCRIPTION	PART #
1	1									CASE 1.25 x 1 NPT	018266
	1	✓		✓	✓		✓	✓	✓	CASE 1.25 X 1 NPT	018268
	1		✓			✓				CASE 1.5 x 1.25 NPT	018267
2	1				✓				✓	IMPELLER 4.88", STAINLESS	018275
	1			✓				✓		IMPELLER 5.25", STAINLESS	018276
	1	✓					✓			IMPELLER 6.3", STAINLESS	018277
	1		✓			✓				IMPELLER 6.3", STAINLESS	018342
4	1	✓	✓	✓	✓	✓	✓	✓	MOTOR 56J	CONSULT FACTORY	
11	1	✓	✓	✓	✓	✓	✓	✓	COVER, STAINLESS	018269	
24*	1	✓	✓	✓	✓	✓	✓	✓	NUT	018270	
30*	1	✓	✓	✓	✓	✓	✓	✓	D-WASHER	018271	
40*	1	✓	✓	✓	✓	✓	✓	✓	FLINGER	018272	
71	1	✓	✓	✓	✓	✓	✓	✓	DISC IRON	018273	
73*	1	✓	✓	✓	✓	✓	✓	✓	GASKET, CASE	018274	
89*	1	✓	✓	✓	✓	✓	✓	✓	SEAL, 5/8"	IN REPAIR KIT	

* - DENOTES COMPONENTS INCLUDED IN REPAIR KIT 018246.

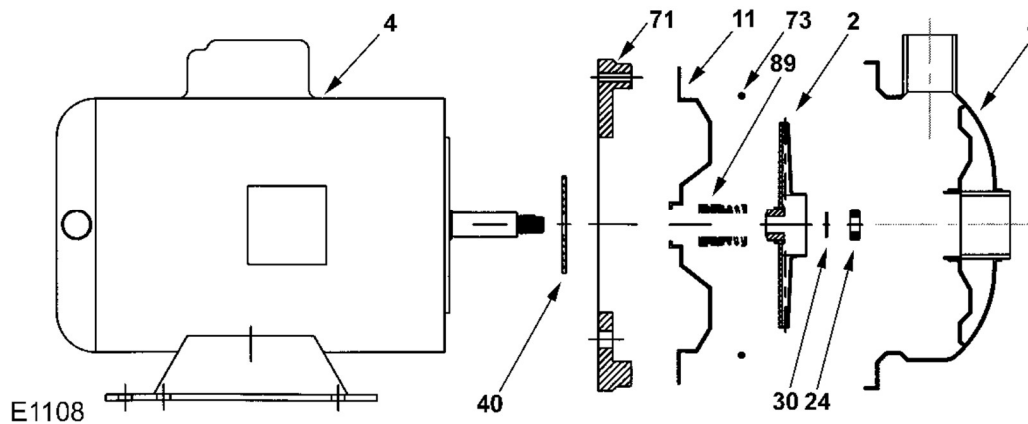

Exploded View Drawing Models: HN, HR, HW, HX, HY, HZ

REF. NO.	QTY.	HN 3.0 HP	HR 1.5 HP	HW 2.0 HP	HX 1.0 HP	HY ¾ HP	HZ ½ HP	DESCRIPTION	PART #
1	1	✓	✓	✓	✓	✓	✓	CASE 1.25 x 1 NPT	018266
2	1				✓	✓		IMPELLER 4.88", STAINLESS	018275
	1						✓	IMPELLER 4.0", STAINLESS	018498
	1		✓	✓				IMPELLER 5.75", STAINLESS	018497
	1	✓						IMPELLER 6.3", STAINLESS	018277
	1							IMPELLER 6.3" STAINLESS	018342
4	1	✓	✓	✓	✓	✓	✓	MOTOR 56J	CONSULT FACTORY
11	1	✓	✓	✓	✓	✓	✓	COVER, STAINLESS	018269
24*	1	✓	✓	✓	✓	✓	✓	NUT	018270
30*	1	✓	✓	✓	✓	✓	✓	D-WASHER	018271
40*	1	✓	✓	✓	✓	✓	✓	FLINGER	018272
71	1	✓	✓	✓	✓	✓	✓	DISC IRON	018273
73*	1	✓	✓	✓	✓	✓	✓	GASKET, CASE	018274
89*	1	✓	✓	✓	✓	✓	✓	SEAL, 5/8	IN REPAIR KIT

* - DENOTES COMPONENTS INCLUDED IN REPAIR KIT 018246.

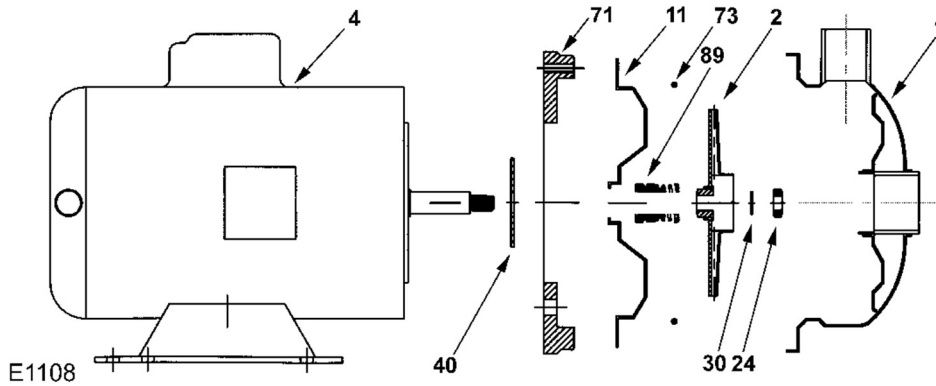

Seal Replacement/Maintenance

Warning: Make certain that the system is disconnected from the power source in compliance with all local and national codes before attempting to service or remove any components. Never run the pump when dry.

Maintenance:

Inspection: Pump should be periodically checked for proper operation. If the system has changed or if the pump is operating noisily or erratically, then the pump should be removed and examined. It should be repaired and parts replaced as necessary.

Cleaning: Remove oil, dust, dirt, water, chemicals from exterior of pump and motor. Blow out interior of open motors with clean compressed air at low pressure. Regularly drain moisture from TEFC motors.

Draining: If the pump is located in an area subject to freezing temperatures, the pump must be drained when not in operation or add sufficient antifreeze.

Seal Replacement:

Disassembly:

- Turn off power.
- Close suction and discharge valves (if equipped).
- Drain pump.
- Remove bolts holding base to foundation.
- Remove casing bolts.
- Remove motor and rotating element from casing, leaving casing and piping undisturbed, if possible. If not, then remove the whole assembly.
- Insert a screwdriver in one of the impeller waterway passages and back off the impeller nut (Ref 24).
- Remove motor shaft end cap. Insert a screwdriver in slot of motor shaft. While holding shaft against rotation, unscrew impeller (Ref 2) from shaft by turning counterclockwise when facing impeller.
- Pry off rotating member of mechanical seal from motor shaft by using two (2) screwdrivers. Be careful not to damage the pump cover (Ref 11).
- Remove pump cover (Ref 11 & 71) from cast iron disc. (There is no hardware used to attach cover to disc.) Place cover on a flat surface with convex side down. Push out stationary member of mechanical seal. It is not necessary to remove the cast iron disc from the motor to replace the seal.

Reassembly:

Caution: The mechanical seal is a precision product and should be handled accordingly. Use care when handling lapped running surfaces of the mechanical seal to ensure they remain clean and are free of chips or scratches.

- Clean gasket and flange faces, seal seat cavity and shaft, in particular, shaft shoulder fitting against impeller.
- Lubricate the seal seat cavity of the cover and the rubber cup or O-ring of stationary seal seat with the lubricating fluid that comes with the mechanical seal or repair kit. Press the stationary seat in seal seat cavity in the cover squarely and evenly using an arbor press (if possible) and the cardboard disc supplied with the seal. Be certain that the lapped face (shiny side) is facing you.
- Position the cover (Ref 11) so that the convex side with the lapped seal seat is facing you. Place the cover on the motor disc and align the holes in the disc with the holes in the cover. (Note: There isn't any hardware required to attach the cover to the motor disc.)
- Apply the lubricating fluid that comes with the mechanical seal or repair kit to the motor shaft and the rubber bellows of the rotary seal. Slide the seal head on the shaft; press the rubber drive band on the rotary head until the lapped face on the head seats firmly against the lapped face of the stationary seat. Install seal spring on head and seal spring retainer on spring. Do not chip or scratch faces during installation. Take extra care to make sure the lapped faces are clean.
- Hold shaft against rotation as described in step 8 of disassembly procedure, then thread impeller on shaft until it is tight against the shaft shoulder. The impeller will compress the seal spring to the proper length assuring correct pressure on lapped faces.
- Replace D-washer (Ref 30) and impeller nut (Ref 24) holding impeller against rotation as indicated in step 7 of disassembly procedure.
- Remove any burrs caused by screwdriver on the vane of impeller in waterway passages.
- Replace motor and rotating element in casing. Be sure that any damaged O-rings are replaced.
- or -
If whole assembly was removed install O-ring on cover. Be sure that any damaged O-ring is replaced.
- Position case (Ref 1), cover (Ref 11), and motor disc (Ref 71) so the holes line up. Install socket head cap screws through the case and cover and thread into motor disc. Tighten all cap screws alternately and evenly until finger tight.
- or -
When whole assembly is removed place pump casing against pump cover. Ensure that impeller eye is centered in pump case and position case, cover and motor disc so that the holes line up. Install socket head cap screws through the case and cover, thread into motor disc. Tighten all cap screws alternately and evenly until finger tight.
- Finish tightening the cap screws alternately and evenly to approximately 6 ft. lbs. torque. Note: It is imperative that screws be tightened alternately and evenly, as this action centers the cover in the casing, assuring proper alignment. Binding of the impeller in the case and adaptor may occur if the cap screws are not tightened as listed above.
- Replace hold-down bolts.
- Check for free rotation after assembly is completed.
- Replace motor shaft end cap.
- Seal all drain openings using pipe sealant on threads.
- Re-prime before starting. Do not start until pump is completely filled with water.

Models: DP, DQ, DV, DX

Exploded View Drawing

REF.	QTY REQ.	DESCRIPTION	PART #
1	1	CASE, 236, 2.0" X 1.5" NPT	018310
2	1	IMPELLER, 236, 304SS, 6.3" DIAMETER	018311
4	1	MOTOR, 7.5 HP, 3/60/208-230/460, 3500 ODP	Contact Factory
	1	MOTOR, 10.0 HP, 3/60/208-230/460, 3500 ODP	Contact Factory
11	1	COVER	018312
14*	1	SHAFT SLEEVE	018313
26*	1	IMPELLER RETAINER	018314
32*	1	KEY	018315
38*	1	SHAFT O-RING	018316
40*	1	FLINGER	018317
71	1	ADAPTER	018318
73*	1	CASE GASKET	018319
89*	1	SEAL, VN-CARB/SIL	018308
89A	1	SEAL SPRING RETAINER	018320
*	*	REPAIR KIT, VN-CARB/SIL	018309

***-DENOTES COMPONENTS INCLUDED IN REPAIR KIT**

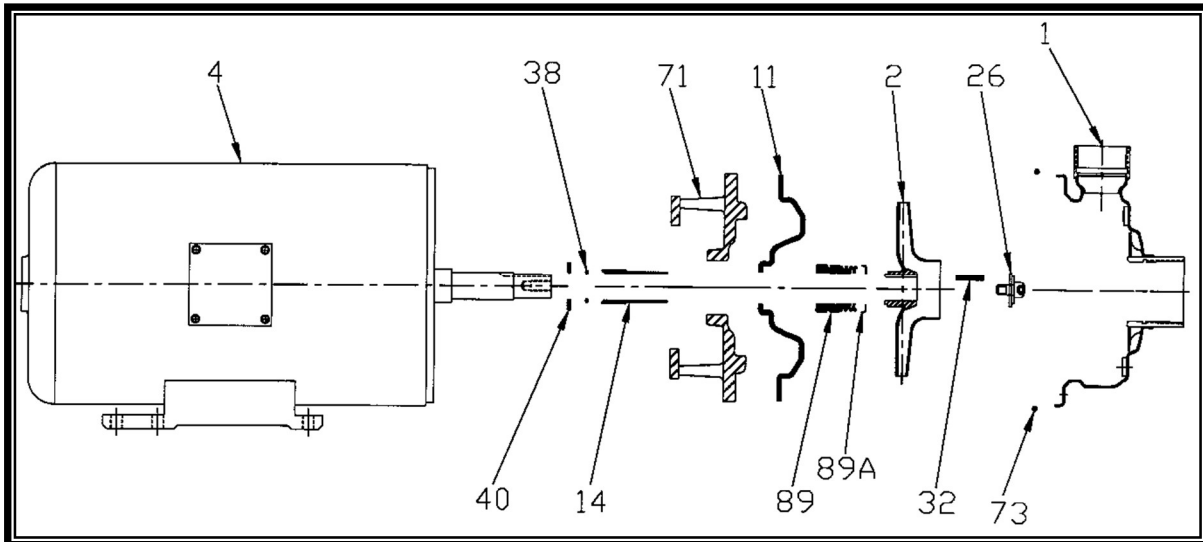

Seal Replacement/Maintenance

Warning: Make certain that the system is disconnected from the power source in compliance with all local and national codes before attempting to service or remove any components. Never run the pump when dry.

Maintenance:

Inspection: Pump should be periodically checked for proper operation. If the system has changed or if the pump is operating noisily or erratically, then the pump should be removed and examined. It should be repaired and parts replaced as necessary.

Cleaning: Remove oil, dust, dirt, water, chemicals from exterior of pump and motor. Blow out interior of open motors with clean compressed air at low pressure. Regularly drain moisture from TEFC motors.

Draining: If the pump is located in an area subject to freezing temperatures, the pump must be drained when not in operation or add sufficient antifreeze.

Seal Replacement:

Disassembly:

- Turn off power.
- Close suction and discharge valves (if equipped).
- Drain pump.
- Remove bolts holding down pump to mounting plate.
- Remove pump from system.
- Remove case.
- Insert a screwdriver in one of the impeller waterway passages and back off the impeller retaining assembly with a socket wrench.
- Remove impeller from shaft, being careful not to lose the impeller key, spring and gasket. If impeller is difficult to remove, it may be necessary to use a bearing puller to remove.
- Pry off rotating member of mechanical seal from motor shaft by using two (2) screwdrivers. Be careful not to damage the pump cover.
- Remove pump cover from cast iron disc. (There is no hardware used to attach cover to disc.) Place cover on a flat surface with convex side down. Push out stationary member of mechanical seal. It is not necessary to remove the cast iron disc from the motor to replace the seal.
- Inspect shaft sleeve. If damage or worn, remove from shaft and replace.

Reassembly:

Caution: The mechanical seal is a precision product and should be handled accordingly. Use care when handling lapped running surfaces of the mechanical seal to ensure they remain clean and are free of chips or scratches.

- Clean gasket and flange faces, seal seat cavity, shaft sleeve, and motor shaft.
- Position cover so that the convex side is facing you. Lubricate the seal seat cavity of the cover and the rubber cup or O-ring of seal seat with the lubricating fluid that comes with the mechanical seal or repair kit. Press the stationary seat in seal seat cavity of the cover squarely and evenly using an arbor press (if possible) and the cardboard disc supplied with the seal. Be certain that the lapped face (shiny side) is facing you.
- Install the flinger on the motor shaft until it bottoms on the motor shaft.
- Slide the shaft O-ring on the motor shaft until it is tight against the flinger. Make sure that the shaft O-ring does not get damaged during this procedure.
- Position the cover so that the convex side with the lapped seal seat is facing you. Place the cover on the motor disc and align the holes in the disc with holes in the over. (There isn't any hardware required attach cover to motor disc.)
- Apply the lubricating fluid that comes with the mechanical seal or repair kit to the motor sleeve and the rubber bellows of the rotary seal. Slide the seal head on the shaft sleeve; press the rubber drive band on the rotary head until the lapped face on the head seats firmly against the lapped face of the stationary seat. Do not chip or scratch faces during installation. Take extra care to make sure the lapped faces are clean.
- Install the seal spring on the seal head and retainer on spring.
- Place key in key seat. Line up keyway in impeller with key on motor shaft. Be certain that the key is positioned in the keyway of the motor and impeller. Slightly compress seal spring with impeller and hold impeller while installing impeller retaining assembly in motor shaft.
- Insert a screwdriver in a waterway passage of the impeller holding it against rotation as discussed in Paragraph g of the disassembly instructions.
- Remove any burrs caused by screwdriver on the vane of impeller in waterway passage.
- Install O-ring on cover. Be sure that any damaged O-ring is replaced.
- Place pump casing against pump cover. Ensure that impeller eye is centered in pump case and position case, cover and motor disc so that the holes line up. Install socket head cap screws through the case and cover, and thread into the motor disc. Tighten all cap screws alternately and evenly until finger tight.
- Finish tightening the cap screws alternately and evenly to approximately 6 ft. lbs. torque. Note: It is imperative that the screws be tightened alternately and evenly, as this action centers the cover in the casing, assuring proper alignment. Binding of the impeller in the case may occur if the case is not positioned properly and/or the cap screws are not tightened as listed above.
- Replace hold-down bolts.
- Check for free rotation after assembly is completed.
- Close all drain openings, using pipe sealant on threads.
- Re-prime before starting. Do not start until pump is completely filled with water.

Models: DB, DC, DF, DG, DJ, DL

Exploded View Drawing

REF.	QTY.	DB	DC	DF	DG	DJ	DL	DESCRIPTION	PART #
1	1	✓	✓	✓	✓	✓	✓	ADAPTOR FRAME	034007
2	12	✓	✓	✓	✓	✓	✓	LOCK WASHER 3/8 x 1/8 S.S.	034004
3	12	✓	✓	✓	✓	✓	✓	HEX HEAD CAP SCREW 3/8-16 x 1" S.S.	034009
4	1	✓	✓	✓	✓	✓	✓	SHAFT DRIVE SLEEVE S.S.	034006
5	1	✓	✓	✓	✓	✓	✓	DRIVE CLAMP ASSEMBLY	034020
6	1	✓	✓	✓	✓	✓	✓	MOTOR 56 C FRAME	Contact Factory
7	1	✓	✓		✓	✓		HOUSING 1 X 3/4	034021
				✓			✓	HOUSING	034027
8	2	✓	✓		✓	✓		PIPE PLUG / GUAGE PORT	017043
9	1	✓	✓	✓	✓	✓	✓	HEX JAM NUT 5/8 - 18 x 5/16 x 3/8 S.S.	034016
10	1	✓	✓	✓	✓	✓	✓	IMPELLER BRASS 5.9"	034025
11	1	✓	✓	✓	✓	✓	✓	GASKET	034014
12	1	✓	✓	✓	✓	✓	✓	SEAL ASSEMBLY	034008
	1							SHIM SET .032 (NOT SHOWN)	034018

NOTE: YOUR PUMP MAY LOOK SLIGHTLY DIFFERENT

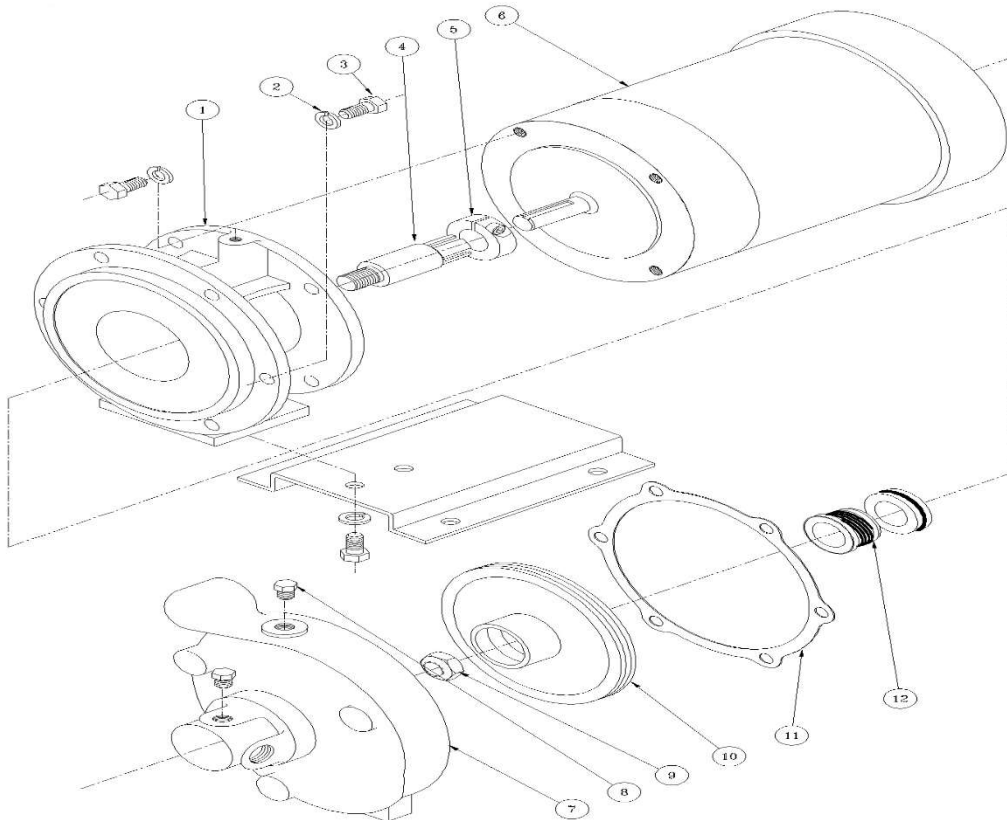

Seal Replacement/Maintenance

Warning: Make certain that the system is disconnected from the power source in compliance with all local and national codes before attempting to service or remove any components. Never run the pump when dry.

Maintenance:

Inspection: Pump should be periodically checked for proper operation. If the system has changed or if the pump is operating noisily or erratically, then the pump should be removed and examined. It should be repaired and parts replaced as necessary.

Cleaning: Remove oil, dust, dirt, water, chemicals from exterior of pump and motor. Blow out interior of open motors with clean compressed air at low pressure. Regularly drain moisture from TEFC motors.

Draining: If the pump is located in an area subject to freezing temperatures, the pump must be drained when not in operation or add sufficient antifreeze.

Seal Replacement:

Disassembly:

- Turn off the electric power and the water supply to the system.
- Drain the system. Flush if necessary.
- Remove the S.S. bolts (Ref 3) holding the housing (Ref 7) to the adaptor frame.
- Remove the two S.S. bolts mounting the assembly to the Mokon system base plate.
- Remove the cap screws, which hold the adaptor frame (Ref 1) to the motor.
- Loosen drive clamp assembly (Ref 5) and remove the pump.

The seal seat and seat cup will remain in the pump adaptor frame. If not damaged or worn, do not remove. If necessary, remove the adaptor frame counter bore with a piece of wood or a screwdriver handle inserted through the adaptor frame from the drive end. A sharp tap or two is usually sufficient to knock out the seal seat. Use caution when removing the seal seat so as not to damage the face or distort the metal seat.

Reassembly:

- Clean all castings with mild cleaning solvent such as kerosene. All dirt and foreign matter should be removed.
- The pump seal assembly must be installed over the clamp end of the drive sleeve. The large diameter end of spring goes against the impeller hub. The small diameter end of the spring rests against the seal cage. The small diameter of the seal cage faces the impeller. The large diameter of the seal cage holding carbon washer faces the adaptor frame holding seal.
- Make sure the drive sleeve is CLEAN and free of nicks or burrs. Use fine steel wool to polish sleeve. Lubricate the sleeve with soapy water.

Note: Do Not Use Oils or S.T.P. They allow the seal bellows to set up too quickly on the sleeve, thus preventing free movement of the seal cage after assembly.

- Lightly lubricate all internal surfaces of bellows, with soapy water.
- Place the spring over the drive sleeve (large diameter end) against the impeller hub.
- Place the seal cage over the sleeve with carbon washer facing away from the impeller.
- Press cage assembly down far enough to compress spring and release. The seal cage will return to free height.
- Lubricate the seal seat cavity with soapy water.
- Lubricate the seal seat gasket with soapy water.
- Use a wood dowel of sufficient diameter to press the seal seat squarely into cavity on pump frame. HAND PRESSURE ONLY

Note: Polished metal surface must face opposite the seal seat cavity on pump frame. Optional ceramic seal assemblies require less pressure to seat squarely, too much pressure will crack ceramic seal.

- Place impeller and seal cage assembly in housing as shown in the above figure. Affix the gasket on the frame over the drive sleeve onto housing.
- Attach the pump frame to pump head with bolts and secure evenly. Install the shaft clamp onto the shaft and attach entire assembly to motor. Tighten the shaft clamp with an Allen wrench.

See the next page to adjust the pump impeller clearance.

Mounting the Motor to the Pump

- Check the rotation of the motor to be sure it coincides with the required rotation of the pump assembly.
- Loosen the drive clamp assembly (Ref 5) but do not remove.
- Slide the pump assembly onto the motor drive shaft, aligning the holes in the adaptor frame (Ref 5) with tapped holes in the motor mounting face, until adaptor frame (Ref 1) contacts the motor mounting face.
- Install two cap screws (diagonally opposite) and tighten to secure the pump assembly to the motor.
- Center the drive clamp assembly (Ref 5) and tighten.
- Proceed to the next page to check the impeller clearance.

Impeller Removal

- Remove seal bellows and spring assembly (Ref 12).
Note: The seal bellows will be bonded to the shaft sleeve and will require some patience and caution to remove in order not to damage the seal bellows and cage.
- Place the impeller drive sleeve (Ref 4) between two pieces of wood in a vise. Take care so as not to damage sleeve.
- Remove the impeller jam nut (Ref 9) from the end of the shaft sleeve. Unthread the impeller (Ref 10) by turning counterclockwise (left hand).

Inspection

Check all parts for wear. For ease of reassembly, the shaft sleeve should have all nicks and burrs removed. Replace damaged parts with new parts. Inspect the seal seat and seal cup for grooves; scuff marks, or other deterioration. If a perfect lapped surface remains on the seal seat, it may be reused. If the seal cup is in good condition, it may be reused. If the seal seat, cup, washer, or bellows are damaged or worn, a new seal assembly should be installed (See Models: DB, DC, DF, DG, DT, DL; under Section 4.2 Pump Maintenance for seal replacement).

Impeller Clearance Adjustment

Impeller face and back clearances are not critical. The impeller must be adjusted axially so that it does not rub, that is it should be centered in the space between the adaptor frame and housing.

After the pump has been installed on the motor with two cap screws, the impeller can be adjusted as follows:

- Center the drive clamp assembly (Ref 5) and tighten.
- Loosen the two cap screws holding the pump to the motor (not shown).
- Pull the motor away from the pump and insert the .032" (.813 mm) shims (Ref 12) between the pump adaptor frame (Ref 5) and the motor. Align the holes in the shims so that remaining two cap screws can be installed.
- Install the remaining two cap screws and tighten all four.
- Rotate motor slowly by hand to make certain the impeller does not rub the housing or adaptor frame.

If the impeller still rubs, loosen the drive clamp assembly (Ref 5), remove two of the cap screws and shims (not shown), loosen the other two cap screws and repeat above procedure.

If the above procedure does not stop the impeller from rubbing, CONSULT THE FACTORY.

Models: DA, DD, DE, DH, DK, DM

Exploded View Drawing

REF.	QTY.	DESCRIPTION	PART #
1	1	CASE, 50, 2.0" X 1.5" NPT, IRON - 5, 7.5 HP	018321
		CASE, 52, 2.5" X 2.0" NPT - 10 HP	018333
2	1	IMPELLER, 50, IRON 6.25" - 5 HP	018322
		6.5" - 7.5 HP	018323
		IMPELLER, 52, IRON 6.5" - 10 HP	018334
4	1	MOTOR, 5.0 HP, 3/60/208-230/460, 3500, ODP	Consult Factory
		MOTOR, 7.5 HP, 3/60/208-230/460, 3500, ODP	Consult Factory
		MOTOR, 10 HP, 3/60/208-230/460, 3500, ODP	Consult Factory
14*	1	SHAFT SLEEVE	018324
25	1	WEAR RING, 50	018325
		WEAR RING, 52	018335
26*	1	IMPELLER RETAINER	018326
32*	1	KEY	018315
38*	1	SHAFT O-RING, VITON	018328
40*	1	FLINGER	018317
71	1	ADAPTER	018328
73*	1	CASE GASKET	018329
89*	1	SEAL, VN-CARB/SIL	018330
89A*	1	SEAL SPRING RETAINER	018331
	*	REPAIR KIT, VN-CARB/SIL	018332

NOTE: YOUR PUMP MAY LOOK SLIGHTLY DIFFERENT

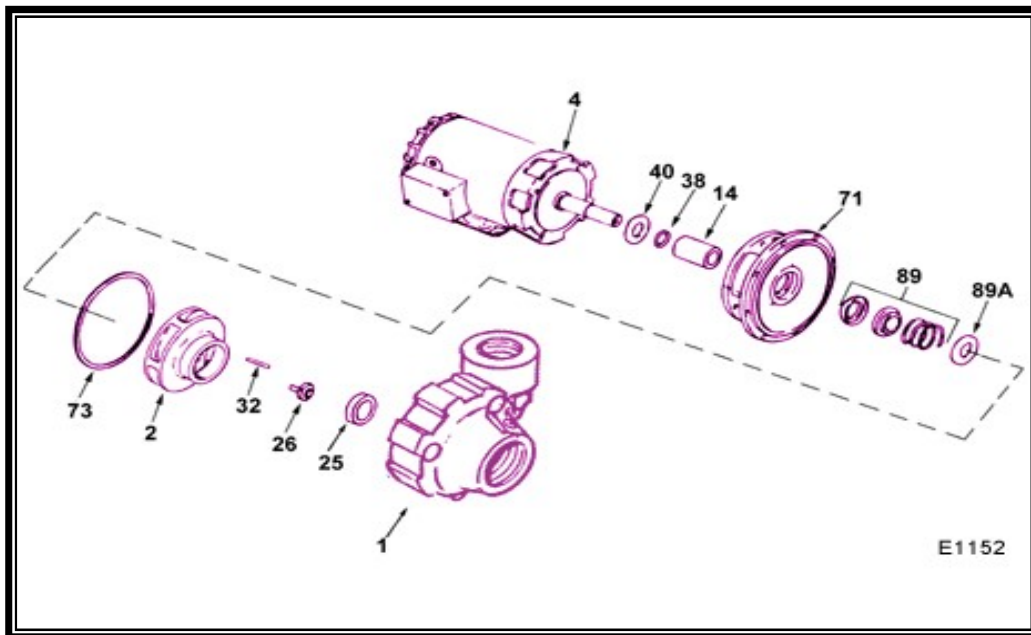

Seal Replacement/Maintenance

Warning: Make certain that the system is disconnected from the power source in compliance with all local and national codes before attempting to service or remove any components. Never run the pump when dry.

Maintenance:

Inspection: Pump should be periodically checked for proper operation. If the system has changed or if the pump is operating noisily or erratically, then the pump should be removed and examined. It should be repaired and parts replaced as necessary.

Cleaning: Remove oil, dust, dirt, water, chemicals from exterior of pump and motor. Blow out interior of open motors with clean compressed air at low pressure. Regularly drain moisture from TEFC motors.

Draining: If the pump is located in an area subject to freezing temperatures, the pump must be drained when not in operation or add sufficient antifreeze.

Seal Replacement:

Disassembly:

- Turn off power.
- Close suction and discharge valves (if equipped).
- Drain pump.
- Remove bolts holding base to foundation.
- Remove casing bolts.
- Remove motor and rotating element from casing, leaving casing and piping undisturbed, if possible. If not, then remove the whole assembly.
- Insert a screwdriver in one of the impeller waterway passages and back off the impeller nut.
- Remove impeller from shaft, being careful not to lose the impeller key, spring and seal retainer. If impeller is difficult to remove, it may be necessary to use a bearing puller to remove.
- Pry off rotating member of mechanical seal from motor shaft by using two (2) screwdrivers.
- Remove bolts holding adapter to motor and take off adapter.
- Place adapter on a flat surface with case rabbet facing down, and push out stationary part of mechanical seal.
- Inspect the shaft sleeve, shaft O-ring, and flinger. If damaged or worn remove and replace with a new one.

Reassembly:

Caution: The mechanical seal is a precision product and should be handled accordingly. Use care when handling lapped running surfaces of the mechanical seal to ensure they remain clean and are free of chips or scratches.

- Clean gasket and flange faces, seal seat cavity, shaft sleeve, and motor shaft.
- Lubricate the seal seat cavity of the adapter and the rubber cup or O-ring of seal seat with the lubricating fluid that comes with the mechanical seal or repair kit.
- Press the stationary seat in seal seat cavity of the adapter squarely and evenly using an arbor press (if possible) and the cardboard disc supplied with the seal. Be certain that the lapped face (shiny side) is facing you.
- Install the flinger on the motor shaft until it bottoms on the motor shaft.
- Slide the shaft O-ring on the motor shaft until it is tight against the flinger. Make sure that the shaft O-ring does not get damaged during this procedure.
- Position shaft sleeve chamfer toward motor and slide on motor shaft.
- With motor preferably in vertical position, remount the adapter on motor, making sure the motor shaft does not dislocate or chip the stationary seat of the seal.
- Apply the lubricating fluid that comes with the mechanical seal or repair kit to the stub shaft and the rubber bellows of the rotary seal. Slide the seal head on the stub; press the rubber drive band on the rotary head until the lapped face the head seats firmly against the lapped face of the stationary seat. Do not chip or scratch faces during installation. Take extra care to make sure the lapped faces are clean. Install seal spring on seal head and retainer on spring.
- Place key in key seat. Line up keyway in impeller with key on stub shaft, and slide impeller on stub shaft. Be certain that the key is positioned in the keyway of the stub and impeller. Slightly compress seal spring with impeller and hold impeller while installing impeller retainer assembly in stub shaft.
- Insert a screwdriver in a waterway passage of the impeller holding it against rotation and tighten the retaining assembly as discussed in step 7 of disassembly instructions. The impeller will compress the seal spring to the proper length assuring the correct pressure on the lapped surfaces.
- Remove any burrs caused by screwdriver on the vane of impeller in waterway passage.
- Slide motor and rotating element in casing. Be sure that any damaged O-ring or gasket is replaced.
- Tighten casing bolts alternately and evenly.
- Replace hold-down bolts.
- Check for free rotation after assembly is completed.
- Seal all drain openings using pipe sealant on threads.
- Re-prime before starting. Do not start until pump is completely filled with water.

Model: MT

Exploded View Drawing

REF.	QTY.	DESCRIPTION	PART #
1	1	MOTOR	Consult Factory
2	1	5/8 SLINGER WASHER	034115
3	4	3/8-16 x 3/4" HEX HEAD CAP SCREW S.S.	Standard Hardware
4	1	ADAPTER	034114
5	1	SEAL ASSEMBLY- SILCONE CARBIDE (SEE NOTE BELOW)	034113
6	1	IMPELLER SHIM SET	034112
7	1	IMPELLER	034111
8	1	# 013 O-RING VITON	034110
9	1	7/16-20 ACORN NUT	034109
10	1	# 243 O-RING	034108
11	1	CASING	034107
12	1	1/8" PIPE PLUG S.S.	017044
13	5	1/4 - 20 x 7/8" CAP SCREW S.S.	Standard Hardware

NOTE: WHEN REPLACING SEAL ASSEMBLY (REF 5) A NEW IMPELLER O-RING (REF 8) SHOULD BE USED

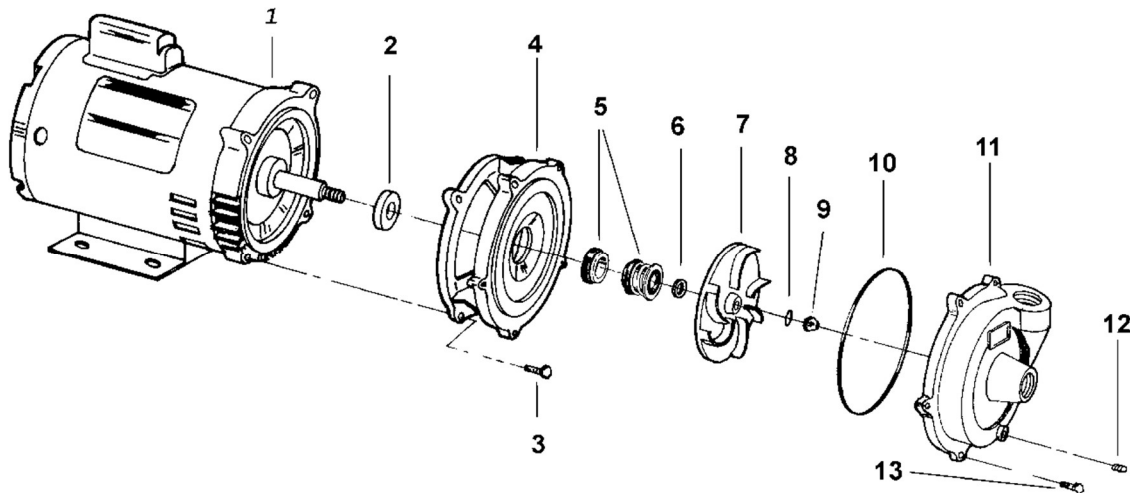

SEAL ASSEMBLY DETAIL

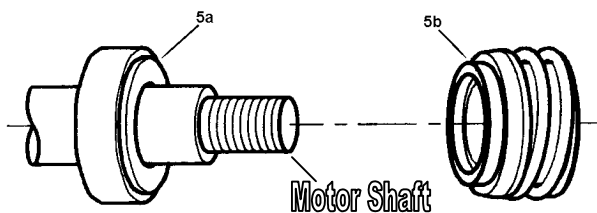

Seal Replacement/Maintenance

Warning: Make certain that the system is disconnected from the power source in compliance with all local and national codes before attempting to service or remove any components. Never run the pump when dry.

Maintenance:

Inspection: Pump should be periodically checked for proper operation. If the system has changed or if the pump is operating noisily or erratically, then the pump should be removed and examined. It should be repaired and parts replaced as necessary.

Cleaning: Remove oil, dust, dirt, water, chemicals from exterior of pump and motor. Blow out interior of open motors with clean compressed air at low pressure. Regularly drain moisture from TEFC motors.

Draining: If the pump is located in an area subject to freezing temperatures, the pump must be drained when not in operation or add sufficient antifreeze.

Seal Replacement:

Disassembly:

Should the mechanical seal, which consists of seal seat (Ref 5a) and seal head (Ref 5b), require replacement, proceed as follows and refer to Figure 1.

Important: Always replace both the seal seat and seal head to insure proper mating of component! Also, the impeller seal should be replaced anytime the impeller lock nut (Ref 9) has been removed.

- Remove five bolts (Ref 13) connecting the casing (Ref 11) to the adaptor (Ref 4)
- Remove the casing.

Caution: Care should be taken not to "pinch" or "shave" the O-ring gasket (Ref 10) between the adaptor and the casing.

- Use a box and/or socket wrench to remove the impeller nut (Ref 9). Remove the impeller seal (Ref 8) and the impeller (Ref 7).

Important: Care should be taken to insure that the same number of shim washers (Ref 6) are placed behind the impeller as was removed. The shim washers are located directly behind the impeller and become loose as the impeller is removed.

- The seal head (Ref 5a) can now be pulled from the shaft.
- Pry the seal seat (Ref 5b) from the adaptor (Ref 4).

Reassembly:

Caution: The precision lapped faces on the mechanical seal are easily damaged. Handle your replacement seal carefully.

- Thoroughly clean all surfaces of the seal seat cavity.
- Using a clean cloth, wipe the shaft and shaft sleeve and make certain that they are perfectly clean.
- Wet the rubber portion of the new seal seat with a light coating of soapy water. While wearing clean gloves or using a clean light rag, press seal seat squarely into adaptor recess. Avoid scratching the white ceramic surface. If seat will not position properly, place a cardboard washer over the polished surface and use a piece of pipe to press in firmly but gently.
- Dispose of cardboard washer. Check again to see that ceramic surface is free of dirt and all other foreign particles and that it has not been scratched or damaged.
- Wet the inside rubber portion of the new seal head with a light coating of soapy water. Slide head onto the motor shaft with the sealing surface facing the seal seat. Reinstall any shims, which have been removed. (See below for Shim Adjustment)
- Thread the impeller onto the motor shaft and replace the impeller seal before screwing the impeller nut into place.
- Reassemble the pump.
- A short "run-in" period may be necessary to provide completely leak proof seal operation.

Shim Adjustment:

When installing a replacement impeller (Ref 7) or motor (Ref 1), it may become necessary to adjust the number of shims (Ref 8) to insure proper running clearance between the impeller and the casing. Proceed as follows:

Note: A proper running clearance is between 0.015" and 0.020" (.38mm and .5mm).

- For impeller replacement, add one (1) shim in addition to those removed originally.
- For motor replacement, add two (2) shims in addition to the shims removed during disassembly.
- Reassemble the pump as described in Steps 2 and 3. (See above for Reassembly)

Important: Insure that the casing is snugly in place and check the shaft to make sure it is turning freely. (Use the screwdriver slot in the motor to turn the shaft). If it turns freely, check to insure that the casing cover and casing fitted "metal to metal" where they meet on the outside. If they are not "metal to metal", tighten the fasteners (Ref 13) and recheck the shaft for free turning. Tighten carefully turning the shaft while tightening so that the motor bearings are not damaged in the event that too many shims were installed. If shaft seizes before fasteners are completely tight, disassemble the pump and remove one (1) and repeat reassembly.

4.3 Cooling Solenoid Valve Maintenance

Note: For systems without a pressure regulator, consult factory for maintenance/troubleshooting procedures of the cooling solenoid valve.



For Mokon temperature control systems equipped with both a cooling solenoid valve and an optional pressure regulator with a safety relief, the following procedure can be used to detect which valve, if any, requires maintenance or replacement.

With the system running cold (below 100°F / 38°C), set controller at 250°F (121°C) and disconnect the 1/4" copper tubing from the pressure relief valve.

- If water comes out of the copper tubing, the solenoid valve may require cleaning or replacement. It may require cleaning, adjustment, or part replacement.
 - To Clean - Remove the coil from the valve. Remove center stem and flush with water. Reassemble.
 - To Replace - Remove the valve from the system and replace.

With a system running at a constant temperature, disconnect the ¼" copper tube from the pressure relief valve.

- If water comes out of the pressure relief valve, then the valve is malfunctioning. The pressure relief valve may need cleaning or replacement.
 - To Clean - Remove the adjust stem, spring, and piston. Clean any debris from the seat and the piston then reassemble the pressure relief valve.
 - To Replace - Remove the pressure relief valve from the system and replace.

4.4 Low Pressure Safety Switch

Mokon Duratherm, Hydrotherm II, and Minitherm systems are equipped with low pressure safety shut down switch as standard. This switch incorporates an interlock to prevent the operation of the system should the supply water be insufficient. The switch is set to shut down at 8 PSI. Consult Mokon Factory If A Problem Is Suspected.

4.5 High Temperature Safety Switch

The High temperature safety shut off switch is located in or just after the heater manifold. This switch is factory set to shut the Mokon temperature control system off. For Mokon temperature control systems operating at a maximum temperature of 250°F (121°C), the switch will shut off the system when the temperature reaches 260°F (127°C). For Mokon temperature control systems operating at a maximum temperature of 300°F (149°C), the switch will shut off the system when the temperature reaches 310°F (154°C). This switch should not be adjusted in the field. Consult Mokon Factory If A Problem Is Suspected.

Note: Refer to Section 1.8 for the No Flow Warning.

4.6 Heater Assembly

Models: DA, DB, DC, DD, DE, DF, DG, DH, DJ, DK, DL, DM, DN, DO, DP, DQ, DR, DT, DU, DV, DW, DX, DY, DZ

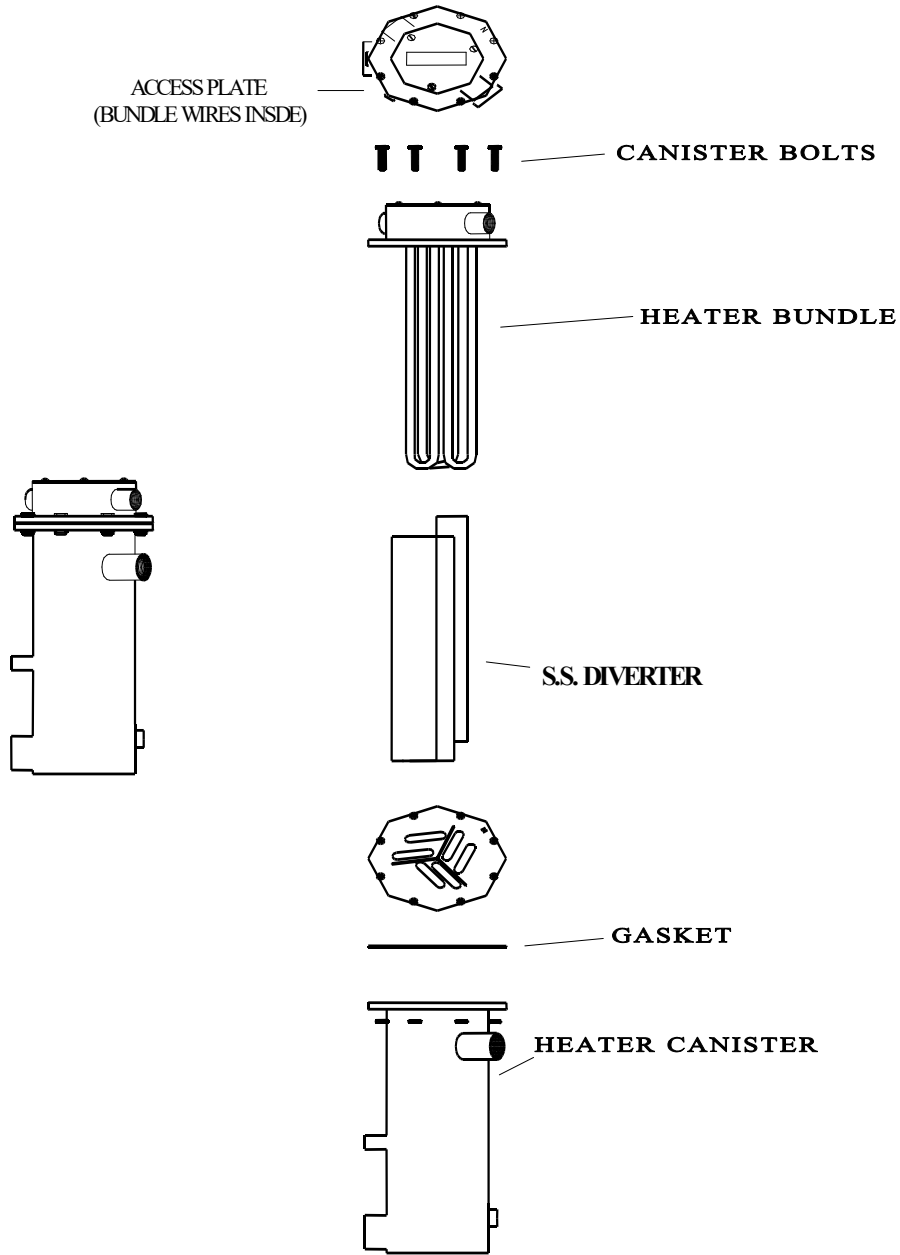

- Disconnect the electric power and the water supply to the system.
- Remove the back access panel to the system.
- Remove the heater bundle access plate.
- Disconnect the heater bundle wires.
- Remove the canister bolts.



- Pull the heater bundle away from the canister. The S.S. diverter is inserted between the heater elements.
Note: the position of the diverter relative to the elements; it must be inserted in the same position for the new heater bundle.

- Clean the canister. Pay particular attention to the flanged area where the gasket sits.

- Insert the diverter between the heater elements of the new heater bundle as follows (see figure to the right):
 - Locate the "N" stamped on the lead end of the heater bundle.
 - Set the heater bundle upright on the lead end with the "N" facing right (3 o'clock position).
 - Hold the diverter upright over the heater bundle with the gap on the top and facing right (3 o'clock position).
 - Slip the diverter straight down between the heater elements so that each section has an equal number of heater elements.

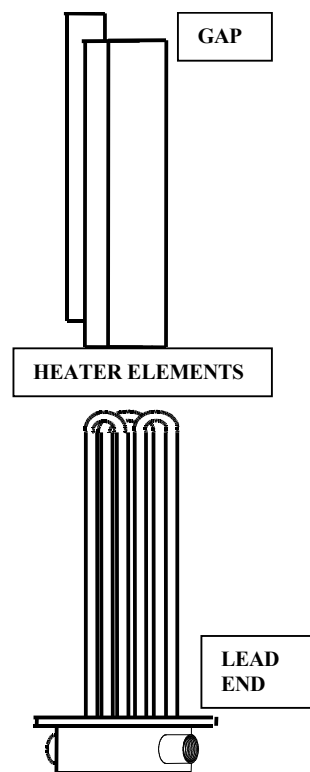

- Insert the new heater bundle into the canister with a new gasket so that the "N" stamped on the lead end is in the 5 o'clock position.
 (See figure below)

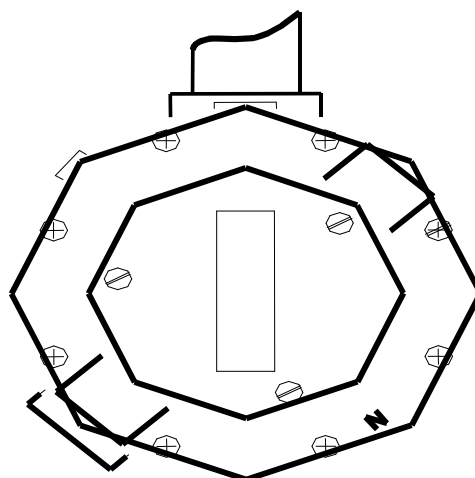

- Replace the canister bolts.
- Reconnect the heater bundle wires as diagramed on the back of the access plate.
- Replace the access plate.

4.7 Heater Element Wiring

Models: HN, HR, HW, HX, HY, HZ, MT

Use the following chart to select between wiring method A and B to wire MOKON replacement heaters (dual element – hair pin type). Refer to the MOKON system electrical schematic for complete heater wiring illustrations.

	190-240 Volts	380-460 Volts	550-575 Volts
Water Systems	A	B	B

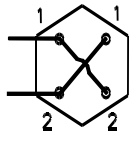
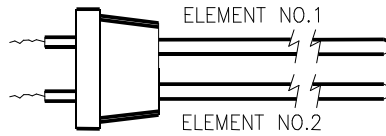
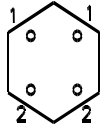

A

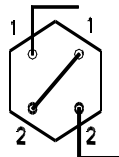

B

Section 5 – Eurotherm Controller (3000 Series)

5.1 Operation

This section of the manual contains all essential information needed to operate the controller. Contact Mokon Customer Service with controller problems as well as warranty and repair issues.

The controller is configured by model number. Inputs, outputs and alarm types are preset. Final setup and configuration are done from the keypad. The controller has four basic modes: Operator 1, Operator 2, Operator 3 and the configuration mode.

The controller's default level is Operator 1, and is used for day to day operation.

Note: Operator 2, 3 and configuration are password protected.

Home List Navigation

To step through list levels press and hold the Page button until level 1 is obtained. Press the up button or the down button to change levels.

To step through parameters within a particular list, press the Scroll button until the required parameter is obtained.

To change the value (or state) of a parameter, press the Up button or the Down button.

***Refer to Section 5.1 Keys for button locations and descriptions.**





Levels	Operator 1		
	Parameter Mnemonic	Scroll	Function
	WRK.OP	WORKING OUPUT The active output value	Output %
	SP1	SETPOINT 1	-----
	SP2	SETPOINT 2	-----
	DWELL	SET TIME DURATION	Auto air purge time setting
	T-REMIN	TIME REMAINING	Time remaining for Auto Air Purge
	* A1.xxx	ALARM 1 SETPOINT	Only shown if the alarm is configured. Where: xxx = alarm type. HI = High alarm; LO = Low alarm d.HI – Deviation high: d.LO = Deviation Low: D.HI = Deviation high
	* A2.xxx	ALARM 2 SETPOINT	
	* A3.xxx	ALARM 3 SETPOINT	
	* A4.xxx	ALARM 4 SETPOINT	
	A.TUNE	Auto Tune Enable	
	ID	Customer ID	Controller Revision #

*Optional

Keys

Note: Pictured is the 3216 Eurotherm controller - this also applies to 3116, 3204 and 3208 series controllers.



Button or Indicator	Name	Explanation
OP1	Output 1	When lit, it indicates that heating output is on. "HEATING" will scroll.
OP2	Output 2	When lit, it indicates that cooling output is on. "COOLING" will scroll.
	Page button	Press to select a new list of parameters.
	Scroll button	Press to select a new parameter in a list.
	Down button	Press to decrease a value in the setpoint.
	Up button	Press to increase a value in the setpoint.
*ALM	Alarm	Flashes when in alarm condition. "ALARM MESSAGE" will scroll.
OP4	Output 4	When lit indicates that the air purge output is on. "AUTO AIR PURGE" will
RUN	Timer Running	When lit indicates that the air purge output is on. "AUTO AIR PURGE" will

5.2 Automatic Tuning

In tuning, you match the characteristics (PID parameters) of the controller to those of the process being controlled in order to obtain good control. Good control means:

- Stable, 'straight-line' control of the PV as set point without fluctuation.
- No overshoot or undershoot, of the PV set point.
- Quick response to deviations from the set point caused by external disturbances, thereby rapidly restoring the PV to the set point value.
- Tuning involves calculating and setting the value of the parameters listed in the table below.

The PID controller consists of the following parameters:

Parameter	Meaning or Function
Proportional Band	The proportional term, in display unit or %, delivers an output which is proportional to the size of the error signal.
Integral Time	Removes steady state control offsets by ramping the output up or down in proportion to the amplitude and duration of the error.
Derivative Time	Determines how strongly the controller will react to the rate of change in the measured value. It is used to prevent overshoot and undershoot and to restore the PV rapidly if there is a sudden change in demand.
High Cutback	The number of display units, above set point, at which the controller will increase the output power, in order to prevent undershoot on cool down.
Low Cutback	The number of display units, below set point, at which the controller will cut back the output power, in order to prevent overshoot on heat up.
Relative Cool Gain	Only present if cooling has been configured. Sets the cooling proportional band, which equals the heat proportional band value divided by the cool gain value.

The controller uses a one shot tuner which automatically sets up the initial values of the parameters listed in the table.

The 'one-shot' tuner works by switching the output on and off to induce an oscillation in the measured value. From the amplitude and period of the oscillation, it calculates the tuning parameter values.

If the process cannot tolerate full heating or cooling being applied, then the levels can be restricted by setting the high power limit ('O P .HI') and low power limit ('O P .LO'). However, the measured value *must* oscillate to some degree for the tuner to be able to calculate values.

A One-Shot tune can be performed at any time, but normally it is performed only once during the initial commissioning of the process. However, if the process under control subsequently becomes unstable (because its characteristics have changed), you can re-tune again for the new conditions.

It is best to start tuning with the process at ambient conditions and with the SP close to the normal operating level. This allows the tuner to calculate more accurately the low cutback and high cutback values that restrict the amount of overshoot or undershoot.

How to Tune:

- Set the setpoint to the value at which you will normally operate the process.
- Operator level 1 list, press,  until A.Tune appears. Set to ON.
- Press the Page and Scroll buttons together to return to the Home display. The display will flash [tunE] to indicate that tuning is in progress.
- After one (1) minute to determine steady state conditions the controller will induce an oscillation in the temperature by turning the output on and then off. The first cycle will not complete until the measured value has reached the required setpoint.

5.3 Troubleshooting

Diagnostic Alarms:

Display Shows	What it means	What to do about it
E.ConF	A change made to a parameter takes a finite time to be entered. If the power to the controller is turned off before the change has been entered then this alarm will occur. <i>Do not</i> turn the power off to the controller while ConF is flashing.	Enter configuration mode then return to the required operating mode. It may be necessary to re-enter the parameter change since it will not have been entered in the previous configuration.
E.CAL	Calibration error	Re-instate Factory calibration
E2.Er	EEPROM error	Return to factory for repair
EEEr	Non-vol memory error	Note the error and contact your supplier
E.Lin	Invalid input type. This refers to custom linearization which may not have been applied corrector or may have been corrupted.	Go to the INPUT list in configuration level and set a valid thermocouple or input type.

Note: Some error messages may not appear, depending on the controller options.

5.4 Alarm Indicators

- ALM beacon flashing red = a new alarm (unacknowledged).
- This is accompanied by a scrolling alarm message. A typical default message will show the source of the alarm followed by the type of alarm. For example, "ALARM 1 FULL SCALE HIGH".
- If more than one alarm is present further messages are flashed in turn in the main display. The alarm indication will continue while the alarm condition is present and is not acknowledged.
- ALM beacon on continuously = alarm has been acknowledged.

To Acknowledge an Alarm

Press  and  together.

Non-Latched Alarms

Alarm condition present when the alarm is acknowledged.

- ALM beacon on continuously.
- The alarm message(s) will continue to scroll.

This state will continue for as long as the alarm condition remains. When the alarm condition disappears all indication also disappears.

If the alarm condition disappears before it is acknowledged the alarm reset immediately.

5.5 Automatic Air Purge Operation (Start-Up)

All systems with this controller are equipped with our auto-air purge function, it is factory set for five (5) minutes. When the system is started, the controller will operate a timer for five (5) minutes. The controller should be set at the minimum temperature, and the scrolling text will read "Auto Air Purge." OP4 and Run will illuminate on the controller. The system should automatically be purged of air at the end of the five (5) minute timer. If pressure gauges are still erratic or air appears to still be present, refer to Section 5.6 for restarting the automatic air purge timer.

Adjusting Auto Air Purge Timer (Factory Default Set for 5 Minutes)

- Press scroll button, toggling until you see the parameter DWELL.
- Using the arrow keys, change to desired setting
- The DWELL parameter relates to time in minutes. (The amount of time it will take to purge your process loop will be affected by the size of the loop and the backpressure on your drain.)
- Wait for the display to flash.
- Press Page button.
- Unit will return back to the normal user screen.







Symbols:

	Page button
	Scroll button
	Down button
	Up button

Refer to Section 3.1 for Initial Starting Procedure for air bleed and air separator devices on process.

5.6 Restarting the Automatic Air Purge Timer (After Start-Up)

After the original start-up of the system (Section 5.5), you can Run, Hold, or End the automatic air purge timer.

Operation	Action	Indication
To Run the Timer	Press and quickly release  + 	Beacon - RUN = On OP4 = On Scrolling test display: "AUTO AIR PURGE"
To Hold the Timer	Press and quickly release  + 	Beacon - RUN = Flashing OP4 = On Scrolling test display: "TIMER HOLD"
To End the Timer	Press and hold  +  for more than 1 second	Beacon - RUN = Off OP4 = Off
	Timer has timed out (END state)	Beacon - RUN = Off OP4 = Off

5.7 Manual Air Purge Operation (After Start-Up)

There is a manual purge button that can be used after the Automatic Air Purge time has expired. This is a momentary push button.

5.8 Remote Set Point and Retransmission "Scaling"

Scaling of the 4-20mA and 0-10V signals for this option are as follows:

- 4mA or 0V = minimum system operating temperature.
- 20mA or 5V, 10V = maximum system operating temperature.

Note: Maximum system operating temperature value is reflective of the series system purchased, (refer to serial tag for maximum operating temperature located on Mokon system).

Consult customer service at Mokon factory (716) 876-9951, regarding system's minimum and maximum temperatures if there are any questions.

Section 6 – Options

6.1 Pressure Regulator

Exploded View Drawing

Note: Pressure regulators are optional on Mokon temperature control systems. The following instructions are only applicable for systems, which have a pressure regulator.

SEAT/STEM MODULE

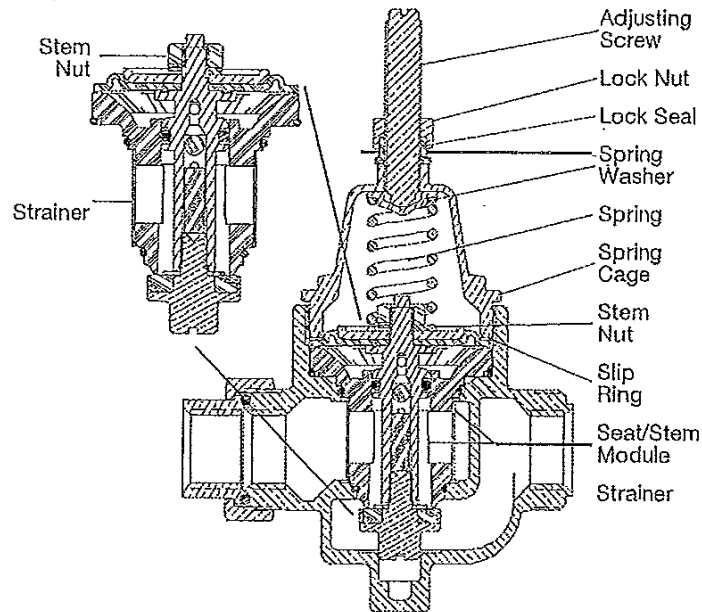

Maintenance Instructions

- To clean strainer or replace seat/stem module shut off supply, loosen locknut and lock seal and back off adjusting screw.
- Remove spring cage, spring, washer and slip ring. Grasp stem nut with fingers or pliers and lift module from body.
- Replace module and reassemble valve.
- Readjust pressure setting.

Adjustment

To adjust the pressure setting, loosen the lock nut and turn the adjusting bolt clockwise to increase pressure, counterclockwise to decrease pressure so that the suction pressure gauge reads the recommended ratings as stated in Sections 1.4 or 1.5 for your model.

Caution: Anytime a reducing valve is adjusted, the use of a pressure gauge is recommended to verify correct pressure setting. Do not bottom out adjusting screw on spring cage.

6.2 Instruction for Initial Start-Up of Non-Pressurized Supply Tank

- Remove the fill port plug for the supply tank located on top of the system.
- Fill the supply tank to the top of the sight glass with fluid.
- With controller set at minimum temperature, press and hold the start button and the air purge button until the fluid is discharged from the tank. Note: On systems equipped with auto air purge pushing the air purge button is not required.
- Repeat steps 2 and 3 until the system is full.
- Final fluid level should be at the top of the sight glass.
- Replace and seal fill port plug.
- With controller at minimum temperature, start system and observe pump pressure gauge. Gauge reading should be steady. If fluctuations in needle are noted, press air purge button to remove trapped air and system's gauge reading is steady. Operate system at the minimum temperature for 10 minutes, observing gauge to insure all trapped air is removed. Check system and process for water or air leaks.
- Recheck fluid level. Adjust if necessary.

Note: Please refer to Section 1.6 if overhead piping will be required.

6.3 Instructions for Initial Start-Up of Pressurized Supply Tank

- Remove the fill port plug for the supply tank located on top of the system.
Note: Do not add air into the tank until step 7.
- Fill supply tank to the top of the sight glass with fluid.
- With controller set at minimum temperature, press and hold the start button and the air purge button until the fluid is discharged from the tank. Note: On systems equipped with auto air purge pushing air purge button is not required.
- Repeat steps 2 and 3 until the system is full.
- Final fluid level (without air pressure in the system should be at the top of the sight glass).
- Replace and seal fill port plug.
- Connect the air supply. Air supply line should be equipped with shut off valve to allow removal of supply line after pressurization
 - Verify the air pressure regulator setting:
 - 35 – 40 psi for units with 250°F maximum temperature.
 - 60 psi for units with 300°F maximum temperature.
 - Remove air supply line.
- With controller at minimum temperature, start system and observe pump pressure gauge. Gauge reading should be steady. Fluctuations in needle are noted, press air purge button to remove trapped air so that system's gauge reading is steady. Operate system at the minimum temperature for 1 minute, observing gauge to insure all trapped air is removed. Check system and process for water or air leaks.
- Recheck fluid level air pressure. Adjust if necessary.

6.4 System "Z" Purge Instructions for All Systems

- A 3 inch diameter threaded pipe connection is provided to receive an air or nitrogen supply, a 90 cfm blower is recommended. This blower shall not be installed or placed in the hazardous environment where hazardous fumes will be drawn from for supply air to the electrical enclosure or internal cabinetry of the Mokon system. The optimum nitrogen or air supply range to the Mokon system should be .15 to .5 inches of water column.

As an alternative to nitrogen, non-hazardous "clean" dry air can be supplied which can also include clean dry compressed shop air.

The discharge pressure of the fan or blower needs to be, at least, 3.0 inches of water column for every 100 equivalent feet of 3" duct. For 4" duct, 1.0 inch of water column per 100 feet is adequate. A 3" exhaust connection is also provided.

Note: Due to temperature considerations, the purge gas must flow (sweep) through the unit to insure adequate ventilation.

- Once the purge gas is introduced, the Dwyer model 1950-0-2F pressure switch will close, energizing a time delay relay. The relay prevents start-up of the Mokon system until an adequate sweep inside the unit has taken place. The switch is set at its minimum setting of 0.15 inches of water. A green pilot light will illuminate once the relay has "timed out", indicating it is safe to operate the unit.
- The magnehelic gauge has a scale of 0 to .5 inches of water, and is clearly visible to allow the operator to monitor the unit.
- If the purge is lost, for any reason, the pressure switch will open, thus activating a customer supplied alarm through a set of auxiliary contacts. The Mokon system will also shut off.
- For systems that are classified and applied properly the applicable Class, Group and Division is listed on the bottom of the systems serial tag.
- Methods: There are typically two methods for the supply of purge gas to systems for "Z" purge applications, they are as follows:

Method # 1 (recommended): Due to temperature considerations, the purge gas must flow (sweep) through the unit to insure adequate ventilation. This method would apply to water, oil, chiller, and full range heater/chiller systems.

Method # 2: (not recommended): Pressurization of the cabinetry when temperature build up is not as much of a concern can be applied. Here the exhaust coupling on the cabinet would be plugged. This method would apply to water-cooled chiller systems or very low heating capacity systems.

Note: If the "Z" purge mechanism or any other system safety devices are modified or disable in any way Mokon considers them to be non-operational and the systems warranty could be void.

6.5 NPS Option

Water Connections

To insure the system can overcome a drain pressure the system should be operated so the discharge pressure of the system is 10 psi greater than drain pressure. To achieve this the system should be equipped with a valve in the process line to restrict flow.

Note: This system is equipped with an automatic fill feature.

Unit Operation

The temperature control unit designed to circulate water through a process and to precisely, automatically and reliably maintain the water temperature at the selected set point temperature. The operating range of the unit is from 70°F (21.1°C) - 180°F (82.2°C). The system is well suited for use with city water, water from chillers, or cooling towers to provide the cooling water supply.

When the system is connected to the power source, an indicating light connected to a level probe inside the tank will indicate whether the water has been filled to the correct level. The system will automatically fill the tank to the correct level using the cooling water supply. When the system is operating and there is too little water in the tank, the lamp lights, the pump stops and heating ceases.

The microprocessor controls the temperature.

If a leak occurs in the mold or in the process, the built-in push-pull system permits stable temperature control without interrupting production.

Through the use of the vacuum adjusting valve, the push-pull system makes it possible to supply pressure to leak and vacuum from the leak back to the unit.

If a leak occurs, the flow through the circuit should be arranged so that the leak is at the end of the water circuit.

Initial Starting Procedure

- Turn on the water supply connected to the Mokon temperature control system. (See Section 2.5 for water connection)
- Turn on the electrical main disconnect switch. (See Section 2.4 for electrical connections)
- If provided, turn on the electrical box door disconnect switch.
- Check the pump rotation by turning on the system momentarily (press the "Start" button then the "stop" button). As the impeller slows down, check the pump rotation. If the pump is not rotating in the direction indicated on the motor (clockwise from the lead end), reverse any two (2) power cord leads to change the direction of pump rotation. (See Section 2.4)
- Restart the system and set the controller to the minimum temperature. (See Section 5 for controller instructions)
- Allow the system to run for several minutes with the controller set to the minimum temperature to remove air from the system.
- Set the controller to the desired temperature. The system will reach the set point temperature. (See Section 5 for controller instructions)

Adjusting the Vacuum

Adjust the positive/negative flow through the mold by using the vacuum adjusting valve on unit back. Start by full closing the valve so that the injector makes a vacuum in the return line from process. At the leak, air is drawn into the circuit. The adjusting valve should be opened slowly to allow water to flow to the mold and pressurize the supply line. The leak will reappear as the pressure increases. At this point, the adjusting valve must be closed until the leak is eliminated.

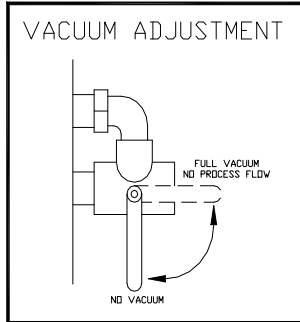

Note: Do not run the system with the vacuum adjust valve in the full vacuum position, as this position allows no flow to the process. Process control could be lost.

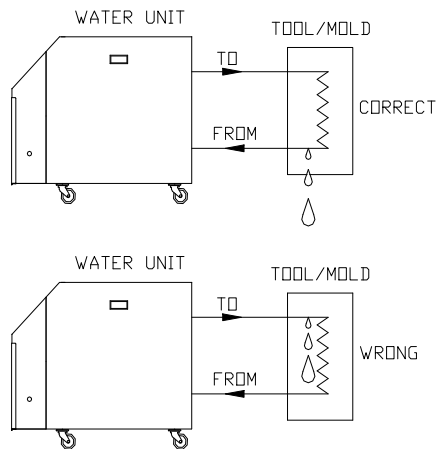

Note: If a tool/mold has a leak the to/from process lines should be adjusted so the leak is closest to the from process connection.

6.6 Operation of Automatic Process (Mold) Purge

Connect compressed air supply (regulated to 5psi) to port labeled air supply. Turn the switch labeled "Mold purge" to the "on" position. This will activate a circuit that will hold open the drain solenoid valve while introducing compressed air (air pressure should be regulated to 5 psi or less) into the process lines to remove fluid from a process.

Note: Water supply must be turned off to the system prior to activating the mold purge switch.

6.7 Cool Down and Automatic Shut Off

This option consists of an activation button labeled Auto Cool/Shutdown, a relay, and a timed relay.

To enable this feature:

While the unit is currently in operation, push the black button labeled Auto Cool/Shutdown. The machine will disable heating and start cooling for the preset amount of time. When the time runs out the machine will shut down.

If needed the machine can still be shut down by pressing the stop button.

A Timed Relay (TDR) mounted inside the machine's electrical enclosure controls the amount of time the machine cools before shutting down. Rotating the dial on the front of the TDR can change the amount of time. The factory-preset time limit is 5 minutes; the adjustable range of the TDR is from zero to ten minutes.

Adjusting Auto Cool Down/Shutdown Timer

(Factory Default Set for 5 Minutes, Adjustable from 0 to 10 Minutes)

- Turn off machine.
- Locate the timer on the electrical subpanel.
- Refer to panel layout drawing for the particular machine, located in the door pocket. The Timer will be designated as auto cool/shutdown time delay relay.
- Turn adjustment dial on timer clockwise to increase time and counter-clockwise to decrease time.
- To determine the proper setting. Heat the machine up to operating temperature. Once you reach operating temperature, turn the set point down to the lowest setting. Start timing the cool down period; as soon as the unit reaches a temperature below 125F you can stop timing. The time you have recorded is where you want to set the auto cool timer to.

6.8 Emergency Stop

The emergency stop device will shut the machine down regardless of the operating mode. Once the emergency stop device has been activated, it must be disengaged by turning the button clockwise. Disengaging the emergency stop will not restart the machinery but only permit restarting.

- Per the risk assessment of the machine, the emergency stop is not wired to a safety rated relay.
- Do not wire additional safety components to the Mokon stop relay **or** modification of the emergency stop circuit is prohibited.

6.9 Valved Process Bypass

This option is simply a direct fluid path between the "TO" process line and the "FROM" process line that will allow you to bypass your process partially or completely via a metered globe valve on the outside back of the unit. This provides a means of controlling the amount of flow out to the process should you wish to reduce it from the normally full flow condition.

Section 7 – Troubleshooting Guide

Problem	Possible Cause	Corrective Measure
System will not start	System unplugged / power off	Plug system in / turn power on
	Low pressure on supply side (water off)	Turn water on
	Improper power source wiring	Check wiring (electrical schematics) and correct
	Blown fuse at power supply	Isolate open fuse and replace
	Blown control circuit fuse	Replace and check for ground condition
	Blown motor branch circuit fusing	Check fuse and replace. Check for ground condition
	Low voltage	Measure incoming voltage, if too low correct
	Overload on pump/motor starter	Consult factory
Circulating pump shut down during operation	Overload on pump/motor starter	Consult factory
	Safety shut down	Consult factory
	Open winding in pump motor	Check motor windings with an OHM meter, if open reading, replace motor
	Refer to possible causes and corrective measures for Problem #1	
Discharge pressure will not build up	Incorrect pump rotation	See Section 3.1 to check and correct pump rotation
	Entrapped air	Press purge button
	Pressure gauges	Inspect/replace instruments
Pressure gauges erratic and system will not hold temperature	Entrapped air	Press purge button
	Cooling solenoid valve or pressure regulator	See Maintenance Section 4.3 to clean valve(s)
High pressure and erratic temperature	Plugged flow paths, inadequate circulation through process and connecting lines	Inspect; if plugged, dislodge
Loss of pressure and volume output	Cooling solenoid valve or pressure regulator	See Maintenance Section 4.3 to clean valve(s)
	Leak in "To Process" line	Repair leak

Problem	Possible Cause	Corrective Measure
Temperature climbs beyond setpoint	Heater contactor	Inspect/replace component
	Temperature controller	See Controller Section 5
	Thermocouple or RTD	Inspect/replace component
	Controller calibration	See Controller Section 5
System does not reach and/or hold temperature	System at end of long feeder line	Install another supply source line
	Cooling solenoid valve or pressure regulator	See Maintenance Section(s) 4.3 and/or 6.1 to clean or replace valve(s)
	Heater burn out	Inspect/replace component
	Heater contactor	Inspect/replace component
	Lime deposits	Clean system (consult factory for recommendations)
	Temperature controller	See Controller Section 5
	Kilowatt capacity inadequate	Consult Mokon engineering
	Loose electrical connections	Tighten connection or replace broken wires
	Thermocouple or RTD	Inspect/replace component
	Controller calibration	See Controller Section 5
Variance in temperature readings	Plugged flow paths, inadequate circulation through process and connecting lines	Inspect; if plugged, dislodge
	Lime deposits	Clean system (consults factory for recommendations)
	Kilowatt capacity inadequate	Consult Mokon engineering
	Thermometers	Inspect/replace component
Leaking water around the motor shaft	Pump seal	See Maintenance Section 4.2 to replace pump seal
Slow response after changing temperature setting	Heater burn out	Inspect/replace component
	Heater contactor	Inspect/replace component
	Lime deposits	Clean system (consult factory for recommendations)
	Kilowatt capacity inadequate	Consult Mokon engineering
	Cooling solenoid valve or pressure regulator	See Maintenance Section(s) 4.3 and/or 6.1 to clean or replace valve(s)
	Thermocouple or RTD	Inspect/replace component

Problem	Possible Cause	Corrective Measure
Fluctuating temperature readings from controller	Lime deposits	Clean system (consult factory for recommendations)
	Thermocouple or RTD	Inspect/replace component
	Controller calibration	See Controller Section 5
Noisy pump	System at end of long feeder line	Install another source line
	Entrapped air	Press purge button
	Cooling solenoid valve or pressure regulator	See Maintenance Section(s) 4.3 and/or 6.1 to clean or replace valve(s)
	Incorrect pump rotation	See Section 3.1 to check and correct pump rotation

Section 8 – Condensed Parts List

8.1 All Models:

Part No.	Description
006257	40 Amp Heater Contactor 120V Coil
006298	50 Amp Heater Contactor 120V Coil
006256	24 Amp Motor Contactor 120V Coil
006373	0.2 – 1.0 Amp Overload
006366	1.0 – 5.0 Amp Overload
006367	3.2 – 16 Amp Overload
006368	5.4 – 27 Amp Overload
006396	5.0 Amp Mini Motor Contactor
006400	0.9 – 1.3 Amp Overload
006401	1.1 – 1.6 Amp Overload
006402	1.4 – 2.0 Amp Overload
006403	1.8 – 2.5 Amp Overload
006404	2.3 – 3.2 Amp Overload
006405	3.5 – 4.8 Amp Overload
008005	0 – 160 PSI Pressure Gauge, Suction, and Discharge
022038	Start/Stop Button
022185	Purge Button
022187	Low Pressure Safety Switch
025183	Adjustable Relief Valve
040002	Thermocouple

Note: Motor starter contactor is dependent on model/date purchase

8.2 Duratherm Models:

DA, DB, DC, DD, DE, DF, DG, DH, DK, DL, DM, DN, DO, DP, DQ, DR, DT, DU, DV, DW, DX, DY, DZ: (Refer to serial tag for kW capacity and voltage)

011026	9 KW Heater Element 460V
011020	18 KW Heater Element 460V
011021	24 KW Heater Element 460V
011023	9 KW Heater Element 230V
011024	18 KW Heater Element 230V
011025	24 KW Heater Element 230V
011036	9 KW Heater Element 208V
011042	18 KW Heater Element 208V
011055	24 KW Heater Element 208V
011029	9 KW Heater Element 575V
011030	18 KW Heater Element 575V
011031	24 KW Heater Element 575V
011053	9 KW Heater Element 380V
011034	18 KW Heater Element 380V
011056	24 KW Heater Element 380V
019036	Heater Canister Gasket
023070	High Temperature Switch (Adjustable)
023090	High Temperature Switch (260°F Preset – Not Adjustable)
023096	High Temperature Switch (310°F Preset – Not Adjustable)

Note: For units built after 05/04/05

8.3 Minitherm Models:

(Refer to on serial tag for kW capacity and voltage)

011001	2 KW Copper Immersion Heater 230V and 460V
011004	2 KW Copper Immersion Heater 575V
011005	2 KW Copper Immersion Heater 208V and 380V
023090	High Temperature Switch
034113	Pump Seal Assembly

8.4 Hydrotherm II Models:

Models HN, HR, HW, HX, HY, HZ: (Refer to serial tag for kW capacity and voltage)

011043	2.25 KW Copper Immersion Heater 230V and 460V
011088	3 KW Copper Immersion Heater 230V and 460V
011089	3 KW Copper Immersion Heater 575V
011090	3 KW Copper Immersion Heater 208V and 380V
018246	Seal Replacement Kit
023090	High Temperature Switch

For additional part numbers refer to the specific section in the instruction manual or consult the Mokon factory (716) 876-9951.

Section 9 – Warranty

DURATHERM-HYDROTHERM II-MINITHERM WARRANTY

LIFETIME WARRANTY

For the life of the system (limited to the original customer) the following are guaranteed to be free of defective material and/or workmanship:

- Pump seal
- Plumbing
- Flow diverter
- All fittings
- Manifolds/heater canister

5 YEAR WARRANTY

For a period of up to 5 years from the date of shipment (limited to the original customer) the following are guaranteed to be free of defective material and/or workmanship:

- Pump housing
- Relief valve
- Standard microprocessor controller*
- Casters

3 YEAR WARRANTY

For a period of 3 years from the date of shipment (limited to the original customer) the following are guaranteed to be free of defective material and/or workmanship:

- Starter
- Low pressure shut off switch
- Motor
- Contactors
- Heater bundle/elements
- Cooling valve

NOTE: Any components not specifically listed are guaranteed to be free of defective material and/or workmanship for a period of 3 years from the date of shipment (limited to the original customer).

*Microprocessor Controllers with Special Features are covered for three (3) years; Solid State controllers are covered for one (1) year.

Upon discovery of any alleged defect, it is the responsibility of the customer to contact the MOKON Service Department with the complete model number, serial number and the date of purchase. MOKON'S obligation under this warranty is limited to make good, from or at its factory, any parts which are returned to the company (prepaid) and deemed to defective, within the time frame of the warranty. The customer also has the option of forwarding the system to MOKON (Buffalo, NY), prepaid by the customer and with a return authorization from MOKON for inspection and component replacement or repair. Repair or replacement in any manner provided above shall constitute a fulfillment of all liabilities of MOKON concerning the quality of the temperature control system.

No allowances, credits or reimbursements will be made for any replacement or repair made or provided for by the customer unless authorized in advance, in writing, by MOKON.

The warranty set forth above is in lieu of any and all other warranties expressed or implied including warranties of merchantability and fitness for a particular purpose. Mokon shall in no event be liable for any consequential damages or for any breach of warranty in an amount exceeding the original price of the unit.

Mokon's products are not guaranteed against damage caused by corrosion.

End of Life Industrial Waste - Saving our Environment

In the interest of preserving our environment, please reclaim, reuse or dispose of any refrigerant, refrigerant oils, heat transfer fluid, glycol and/or water glycol mixtures contained in these systems in accordance with federal, state and local codes, prior to any equipment disposal. All metal and other materials should be repurposed and recycled where possible.



2150 Elmwood Avenue - Buffalo, NY 14207
P# 716-876-9951 - F#716-874-8048 - www.mokon.com