



baby lock

FOR THE LOVE OF SEWING

PROJECT INSTRUCTIONS:

Upcycled Tote

PROJECT INSTRUCTIONS

Upcycled Tote

Think outside of the bag! When you upcycle your own garments or come across fabulous finds from a resale shop, you can refashion unexpected fabrics into one-of-a-kind creations like this cool tote. Crafted from a table runner and canvas fabric, and finished using a serged edge and then woven, it keeps the environment in mind while making a fresh statement. Use your Baby Lock serger and your imagination to create this handy bag that is sure to bring “where did you get that” compliments!

This is made with a section of a 16” x 72” table runner.

Skill Level: Confident Beginner

Created By: Karen Parker, Baby Lock Educator

Supplies:

- Baby Lock Serger
- Serger needles size 80/12 or 90/14
- Baby Lock Sewing Machine
- Sewing machine needle size 90/14 (sharp)
- Woven table runner, cut to 16” x 36”
- Denim (from old jeans, non-stretch works best), 2 pieces 18” x 9”
- Lining 16” x 34” (can be recycled fabric or quilting weight fabric)
- Strips for weaving: 10 strips 18” x 1” (Start with a 12” X 20” rectangle if using yardage)
 - 18 strips 9” x 1” (Start with a 10” x 20” rectangle if using yardage)
 - These can be recycled fabrics or quilting weight fabrics.
 - The strip edges will be finished at the serger. These finished strips will be your “ribbons”.
- Strips for handle/straps:
 - Enough lengths of 1” wide fabric strips sewn together to make a total length of 70”
 - Enough lengths of 2” wide fabric strips sewn together to make a total length of 70”
- 2 yards 7/8” gross grain ribbon, any color (for handle)
- Temporary adhesive spray AND one package of Wonder Tape™
- Thread: 2 cones Madeira Aerolock (neutral color) and two spools of Madeira Lana or Madeira Aeroflock (two different colors for accent). You can use one spool color if you want all the ribbon strips to look the same.
- Regular sewing thread for sewing machine, choose a neutral color that will blend with the color of the 1” strips.
- Rotary cutter, ruler, and mat
- Wonder Clips and pins



- Iron, starch, and ironing surface
- Fine line fabric marker or tailors chalk
- Bodkin or large safety pin

Instructions:

Creating the serger-edged 1 inch “ribbon” strips:

- 1 Cut your strip fabric 12 x 20 if you are using yardage. Starch and then sub cut into ten 18” x 1” strips. (OR cut recycled fabric if using. Starch then sub cut into 18” x 1” strips.)
- 2 Cut your selected strip fabric 10 x 20 if you are using yardage. Starch and then sub cut into eighteen 9” x 1” strips. (OR cut recycled fabric if using. Starch then sub cut into 9” x 1” strips.)
- 3 Cut a few extra 1” strips of any length to practice and audition stitch settings and colors.
- 4 Prepare the serger to stitch a 3-thread overlock stitch with a length of 1 to 1.5 and a width of 6.
- 5 Regular serger thread (like Madeira Aerolock) is in the needle and the lower looper. Madeira Lana or Aeroflock is in the upper looper.

3-Thread Overlock-Narrow

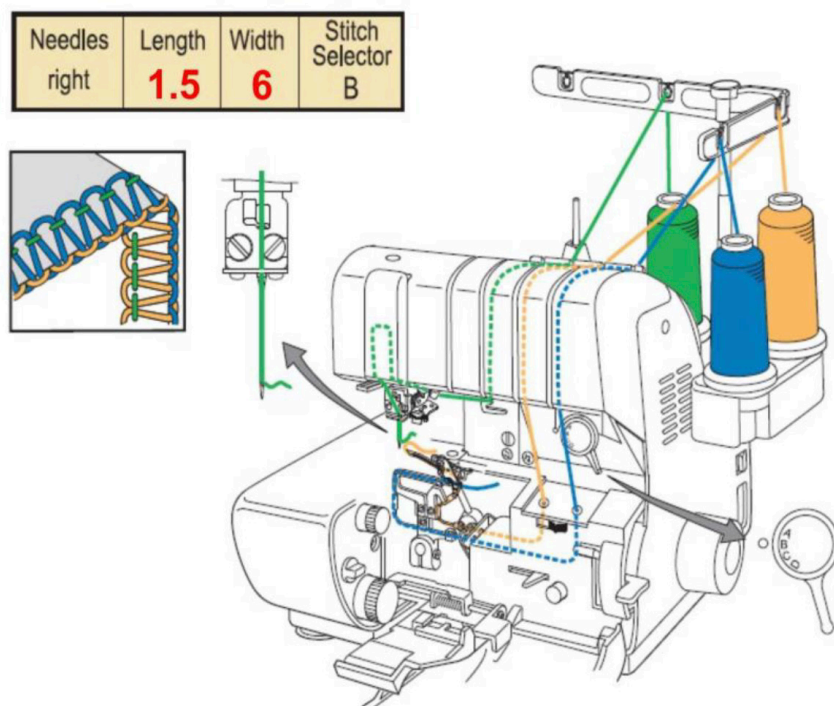

- 6 Finish the long raw edges of each of the 1” ribbon strips. The knife is up, but do not cut off any fabric. The knife should run right along the fabric, just trimming off any loose threads (or whiskers).
- 7 On the sewing machine, stitch the 2” strips for the tote handles together along the short raw edges with right sides together. Press all seam allowances open. Now stitch the short ends of the 1” tote handles with right sides together. Finish the long raw edges of the 1” handle strip as you did the ribbon strips.

Instructions for weaving the front and back panels:



- 8 Find and mark the vertical and horizontal centers of a denim 18" x 9" piece. With a fine line removable fabric marker, draw a grid as follows in Image 1:

Image 1



- 9 Center 5 of the 18" x 1" strips equally between the blue lines as illustrated in Image 2. You may secure the strips in place with a light spray of temporary spray adhesive. Stitch on the pink dotted lines.

Image 2

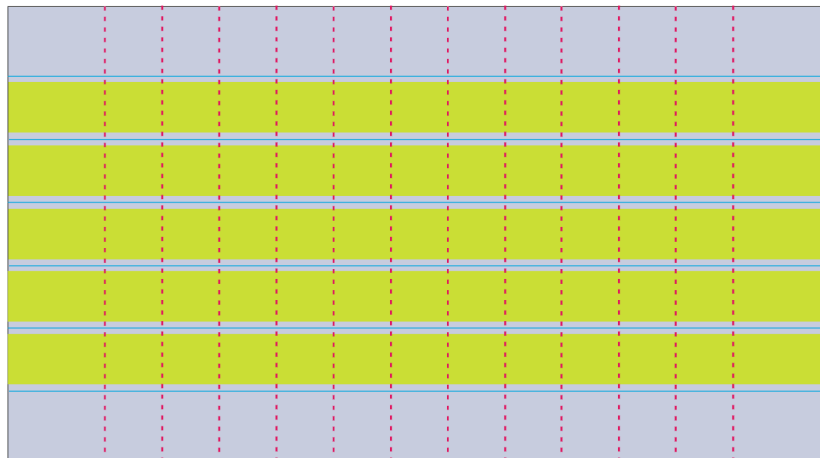

- 10 Weave the 9" long ribbon strips as shown in Image 3. Use a bodkin or large safety pin to help maneuver under and over the horizontal ribbon strips. The two open areas will be used for the handles in a future step.

Image 3

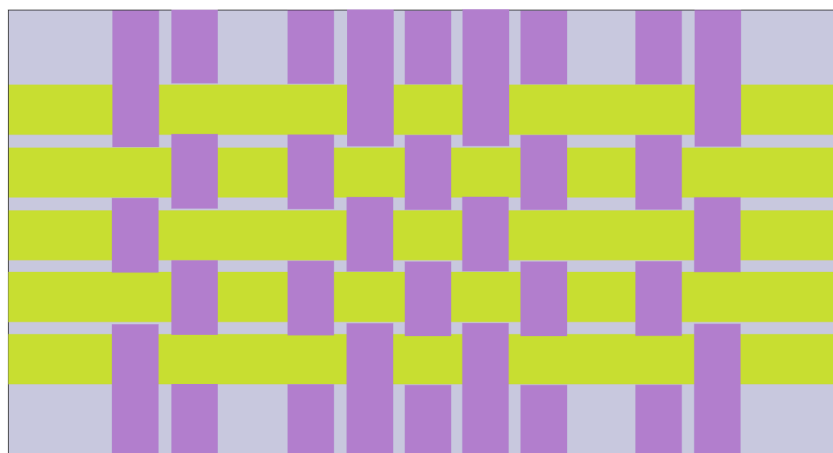

- 11 At the sewing machine stitch along the finished edges of each of the nine 9" ribbon strips as shown in Image 4.

Image 4

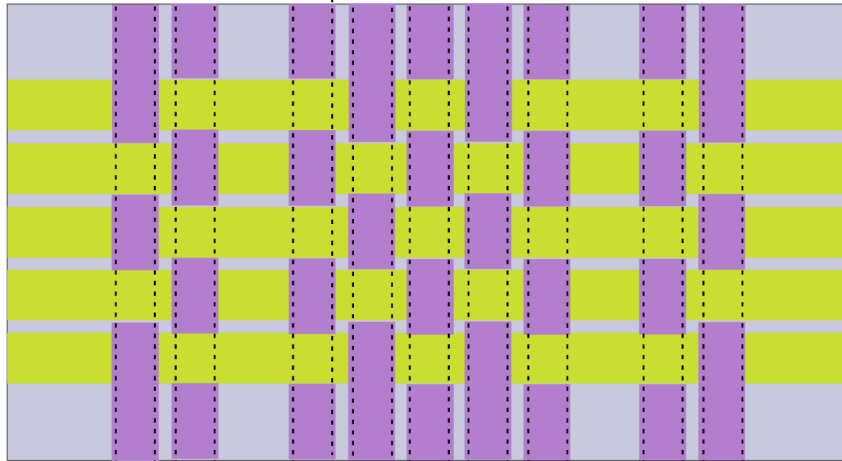

- 12 Clean finish the perimeter of the woven piece with a 3-thread overlock wide. Regular serger thread in the needle and lower looper and Lana (or Aeroflock) in the upper looper.

3-Thread Overlock-Wide

Needles	Length	Width	Stitch Selector
left	2-3	7.5	A

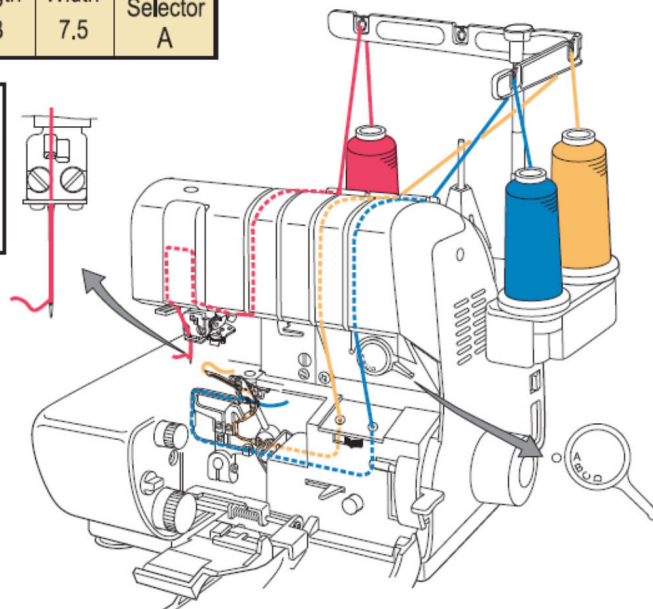
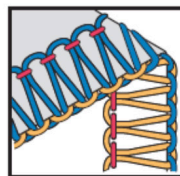

- 13 Repeat steps 8-12 for the remaining denim rectangle.
- 14 Creating the handle/straps for the tote: On the ironing surface place the 2" handle strip wrong side up. Center a piece of Wonder Tape down the entire length of 70". Remove the paper backing from the Wonder Tape and adhere the 7/8" gross grain ribbon, keeping the ribbon centered on the 2" fabric strip as shown in Image 5.

Image 5

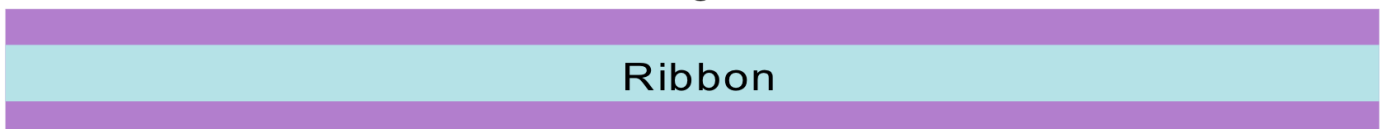

- 15 Fold and press the long edges of the 2” fabric strip so that the raw edges meet, centered over the gross grain ribbon. The gross grain ribbon will no longer be visible. Folding the fabric against the gross grain ribbon edges will aid in keeping the fold even and smooth (shown in Image 6).

Image 6

folded edge



folded edge

Ribbon is inside the folded strip

- 16 Keep the folded and pressed 2” strip facing so you see where the raw edges meet. Spray the entire length with temporary adhesive spray. Center the 1” x 70” ribbon strip on top of the folded 2” strip. Keep all edges aligned and even. At the sewing machine, edge stitch the two strips together along the long edges, staying close to the edge. This is illustrated in Image 7 with red dotted lines.

Image 7

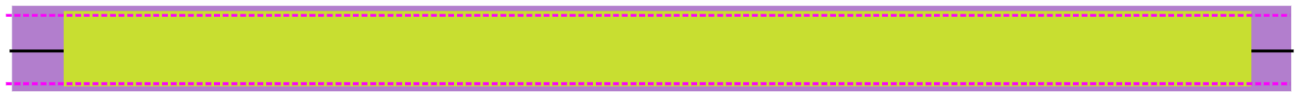

- 17 Positioning the pocket panels: Find and mark the center of the 36” x 16” table runner fabric. Mark two additional lines 3” on either side of the center line. Align the bottom folded edges of the pocket panels with these lines as shown in Image 8. Baste the short ends of the pocket panel to the table runner fabric, keeping the stitch line about 3/8” from edge of table runner fabric.

Image 8

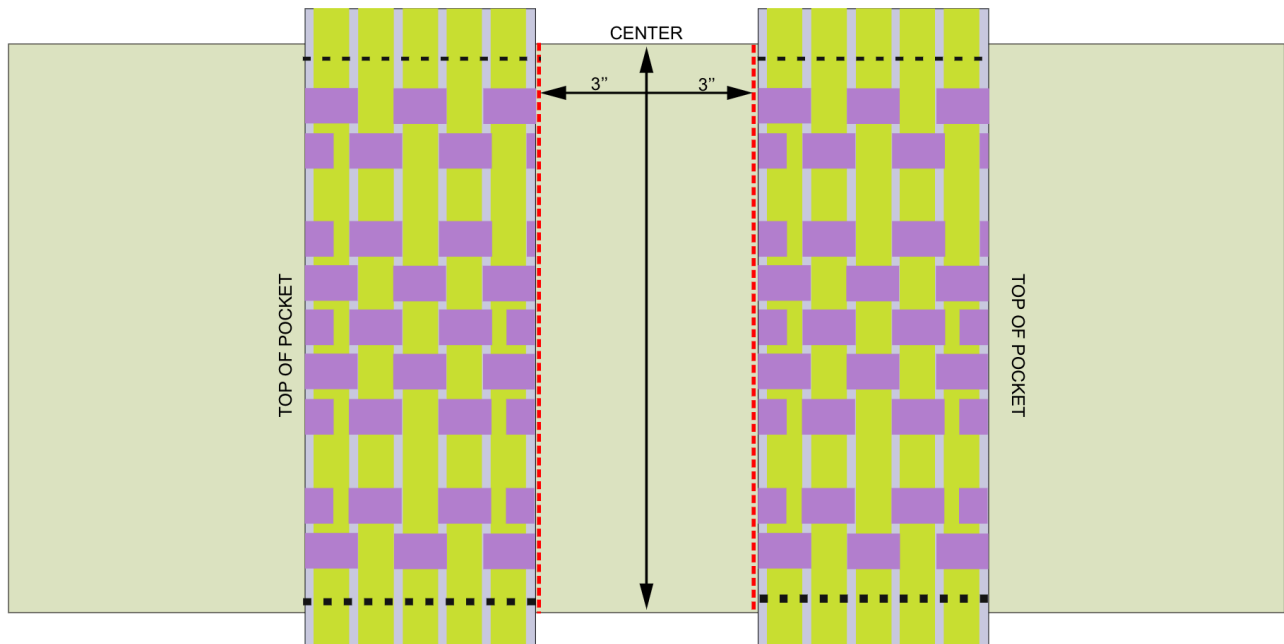

-
- 18 Stitch the top of the pocket panels in the areas illustrated (red dotted lines) in Image 9. Then weave the tote handle/strap through the empty sections of the woven pocket panel (Also shown in Image 9). Approximately 26" of strap should extend beyond the top raw edges of the table runner fabric. You may want to adjust this length for comfort and ease of carrying. It is highly recommended to secure the straps in place with Wonder Tape or Temporary adhesive spray.

Image 9

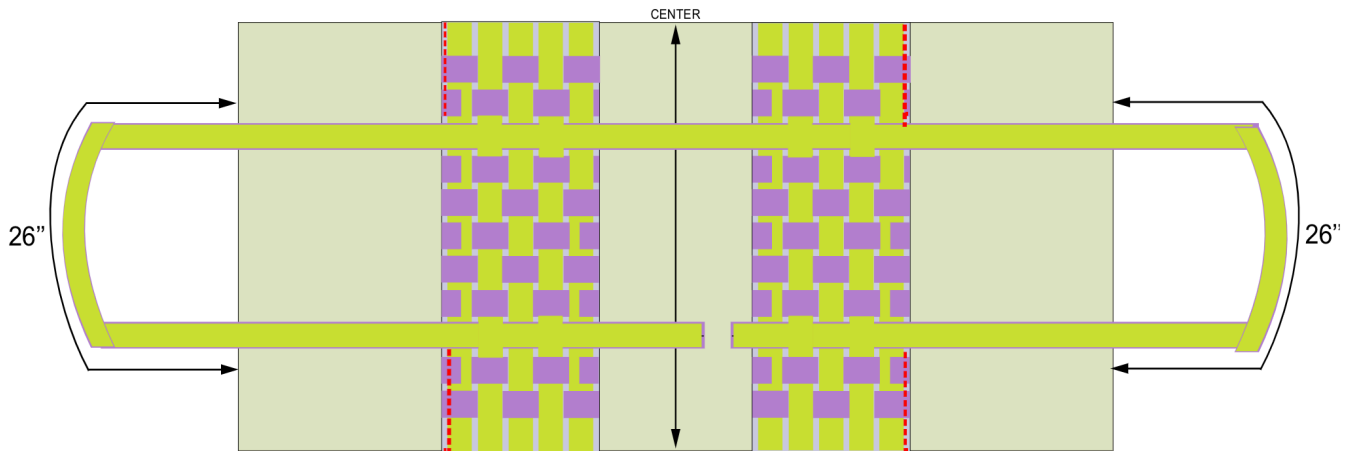

- 19 Tuck the ends of the tote strap under the nearest pocket panel bottom edge (shown in Image 10). Use Wonder Tape to keep them in the correct position for sewing.

Image 10

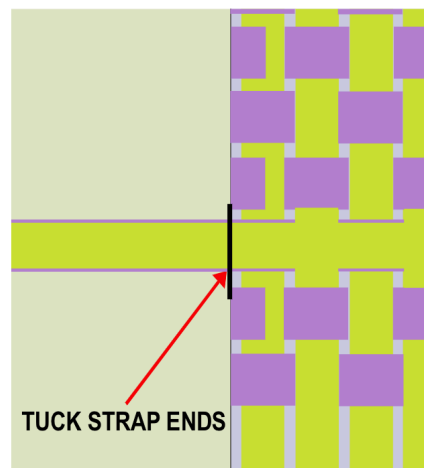

-
- 20 Stitch both edges of the strap to the table runner fabric through all layers, starting 2.5" below raw edge of table runner fabric top edge (shown in Image 11).

Image 11

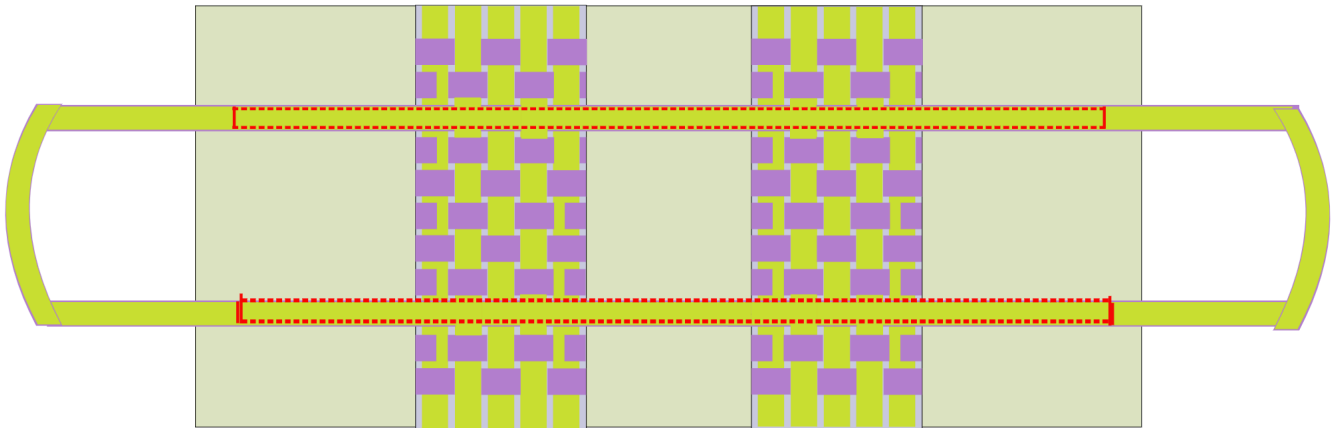

- 21 Stitch the bottom edge of the pockets through all thicknesses as shown in Image 12.

Image 12

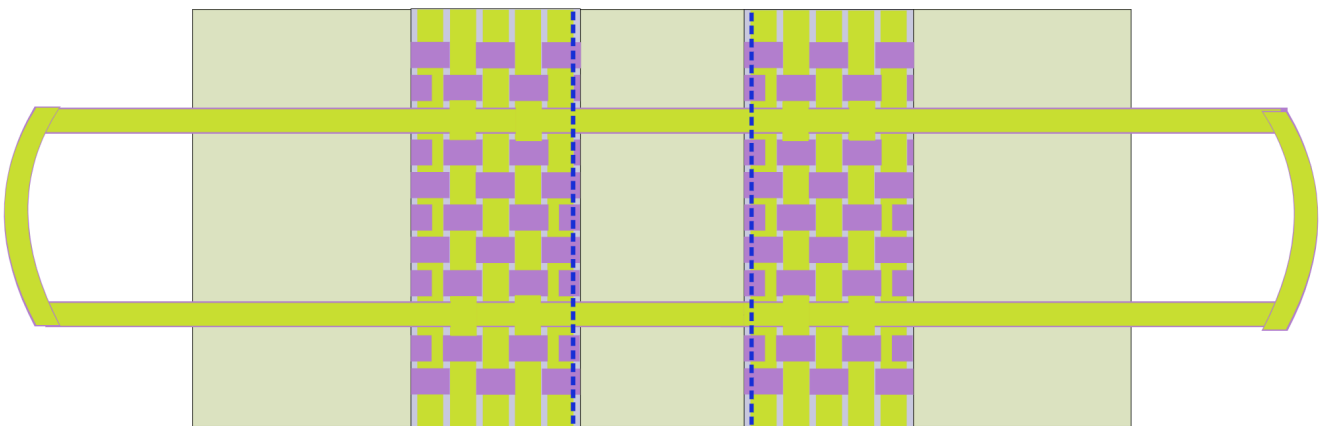

- 22 Note that the lining fabric is 2" shorter than the outer bag/table runner fabric unit. Align a 16" edge of the lining fabric to a 16" edge of the outer bag unit with right sides together and sew with a 1/2" seam allowance. Align the remaining 16" edges and repeat. You now have a tube!

- 23 Press these seam allowances toward the lining fabric side.



- 24 Keeping the “tube” wrong sides out, arrange the tube so the lining raw edges are together and the outer bag raw edges are together as shown in Image 13. If the bottom of the lining is now a fold and the outer bag unit bottom is a fold, you have done it correctly! Make sure to keep the straps of the outer unit out of the seam allowance area. Sew as shown in Image 13. Sew from fold to fold on one side and on the other side leave an opening for turning right side out.

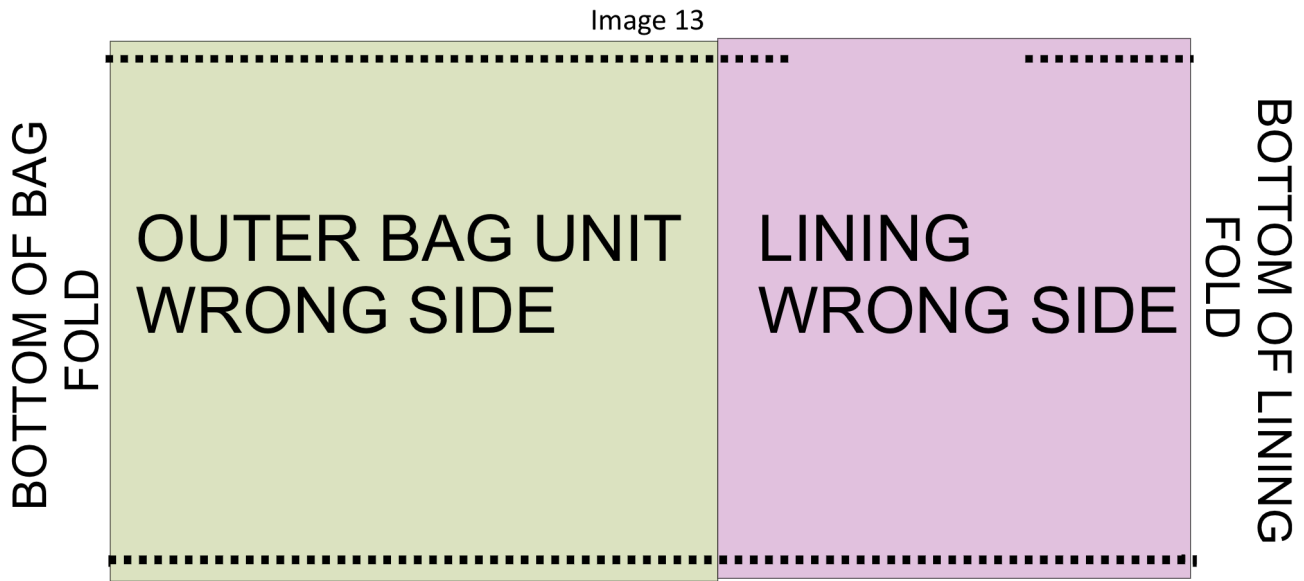

- 25 Box each of the bottom corners. Fold a bottom corner as shown in Image 14. From the corner measure down 1.75” and mark. With a fabric marker draw a line perpendicular to the 1.75” mark. Carefully sew on this line (shown as a red line in Image 14).

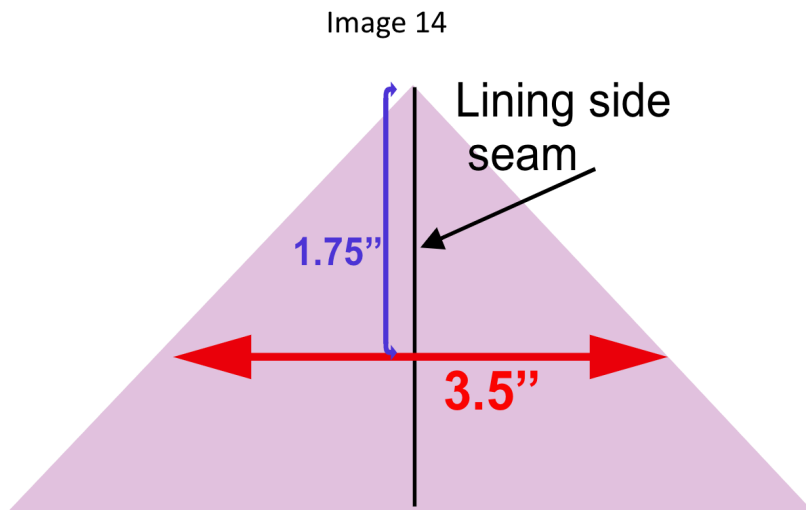

- 26 After boxing all four corners, turn the bag right sides out. Push the lining into the outer bag. The top of the table runner fabric should make approximately a 1” hem. Press that hem. Finally, top stitch the top of the bag about ¼” from the folded edge.
- 27 Now get out there and go shopping with your custom upcycled tote!!

For other exciting projects like this one, visit Baby Lock at www.babylock.com.

©2023 Baby Lock USA. This project may be freely used by individuals for non-commercial purposes. Project instructions may not be sold or distributed without approval from Baby Lock. Baby Lock must be acknowledged as the source of the project instructions through copyright or online link.