

Baby Lock Jazz (BLMJZ) Service Manual



FOR THE LOVE OF SEWING

Table of Contents

1- 6 Cover Removal

Adjustments

- 7 Presser Bar Height
- 8 Center Needle Position
- 9 Needle Bar Height
- 10 Pendulum Timing (ZZ swing)
- 11 Needle Bar Z/Z Limit
- 12 Feed Dog Height
- 13 Feed Dog Block Motion
- 14 Needle/Hook Timing
- 15 Needle/ Hook Clearance
- 16 Outer Hook Replacement
- 17 Position of Bobbin Case Stopper
- 18 Reverse Lever Adjustment
- 19 Stretch Stitch Adjustment
- 20 Buttonhole Bartack Density
- 21 Buttonhole Density Adjustment
- 22 Bobbin Case Tension
- 23 Upper Thread Tension
- 24 Needle Threader Position

Cover Removal

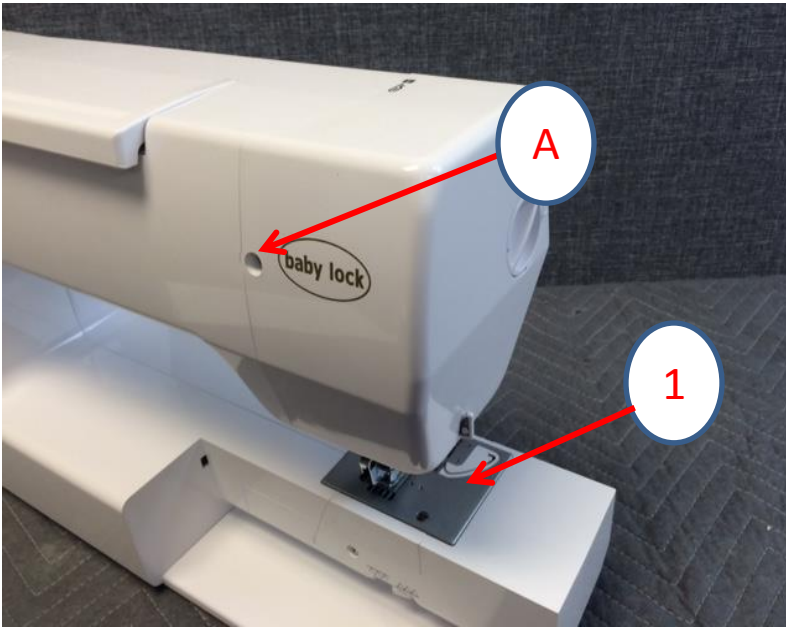

Remove the Needle Plate "1"

Remove screw "A" and slide Face Plate to the left. Be careful not to pull too hard as there is an LED Light attached.

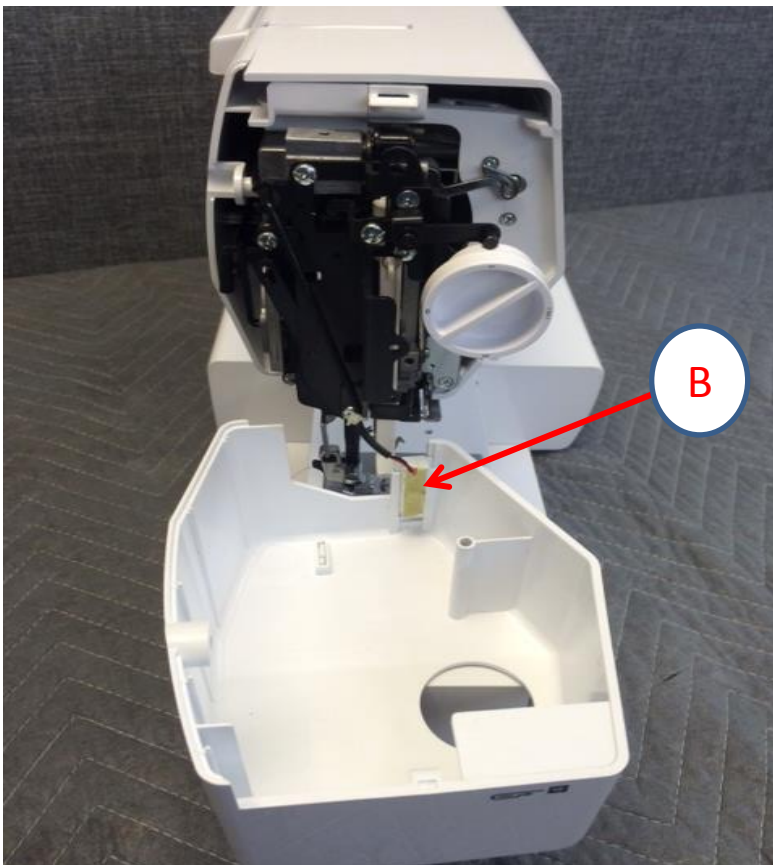

Carefully slide the LED "B" away from the Face Plate.

Cover Removal (Continued)

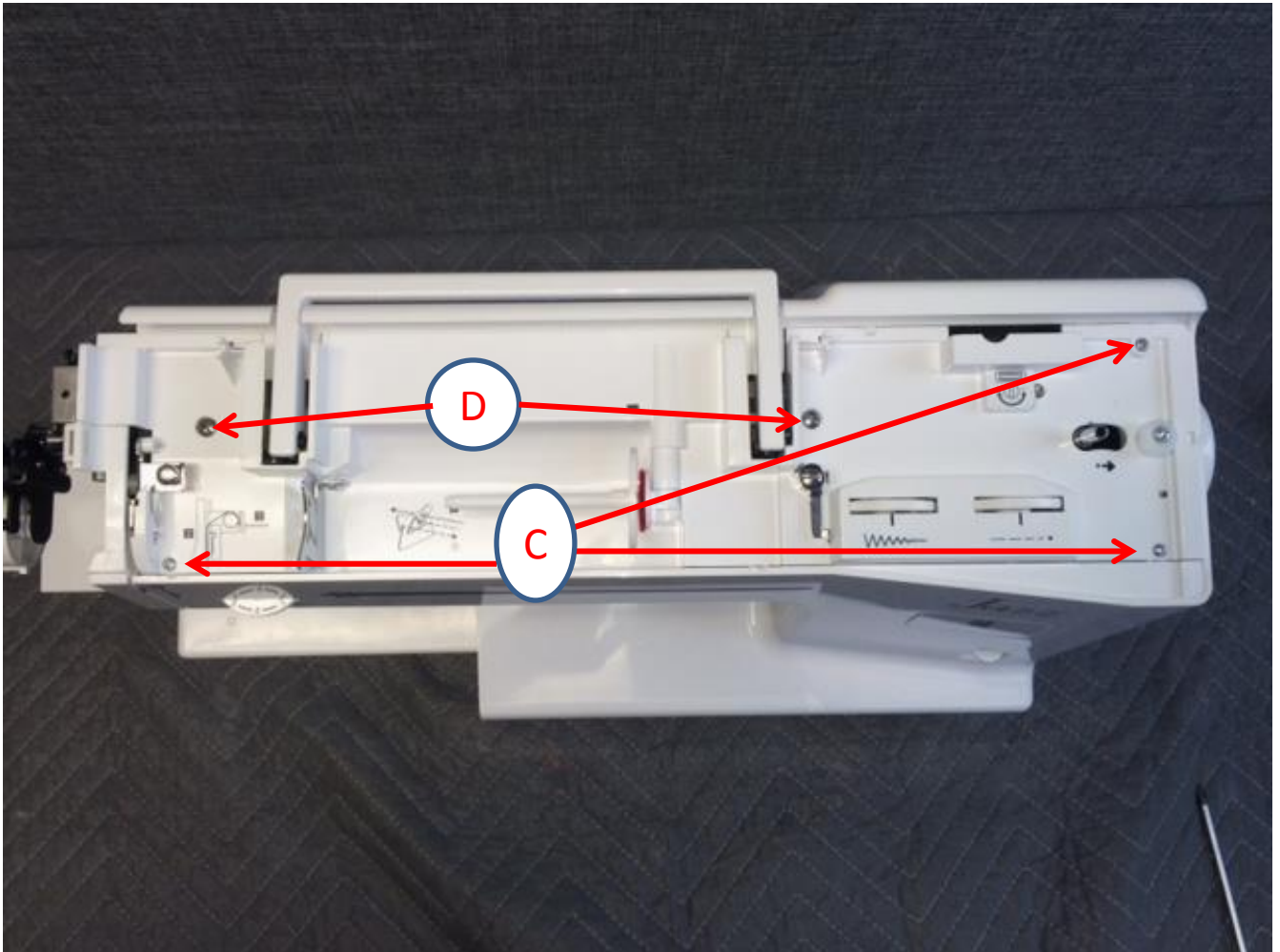

To remove the top cover, begin by removing 3 Screws
“C” then 2 screws “D”. Lift straight up.

Cover Removal (Continued)

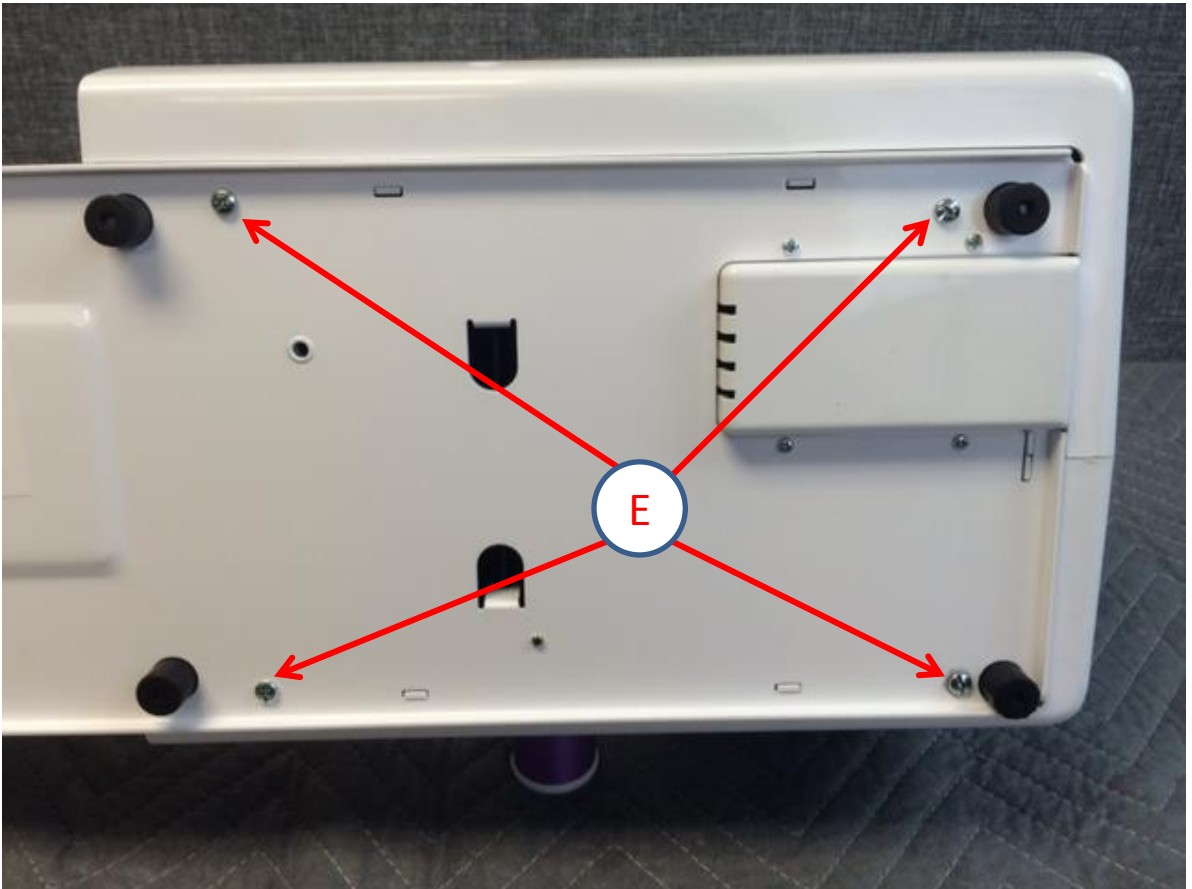

Remove 4 screws " E " and
detach the Bottom Base Cover

Cover Removal (Continued)



Remove screw "F"
from the Free Arm
Cover at the Rear of
machine.

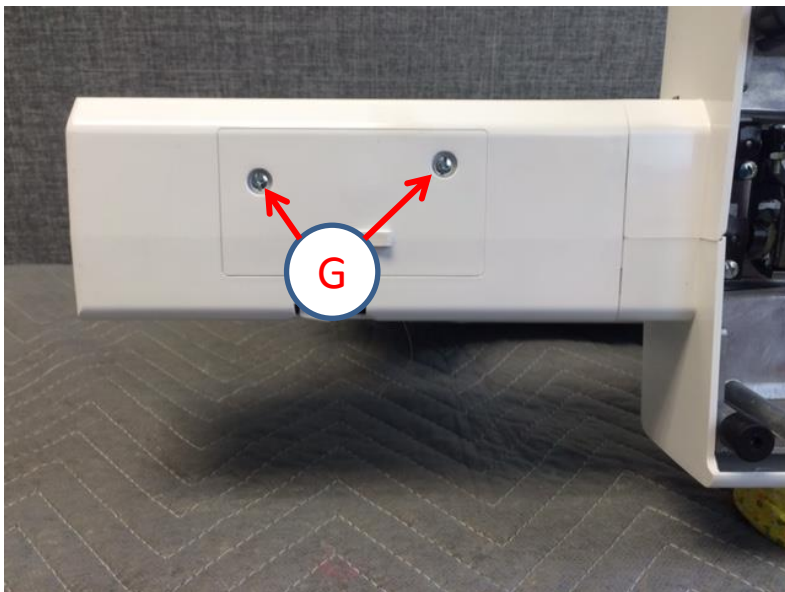

Remove 2 screws
" G " and detach the
Free Arm Cover

Cover Removal (Continued)

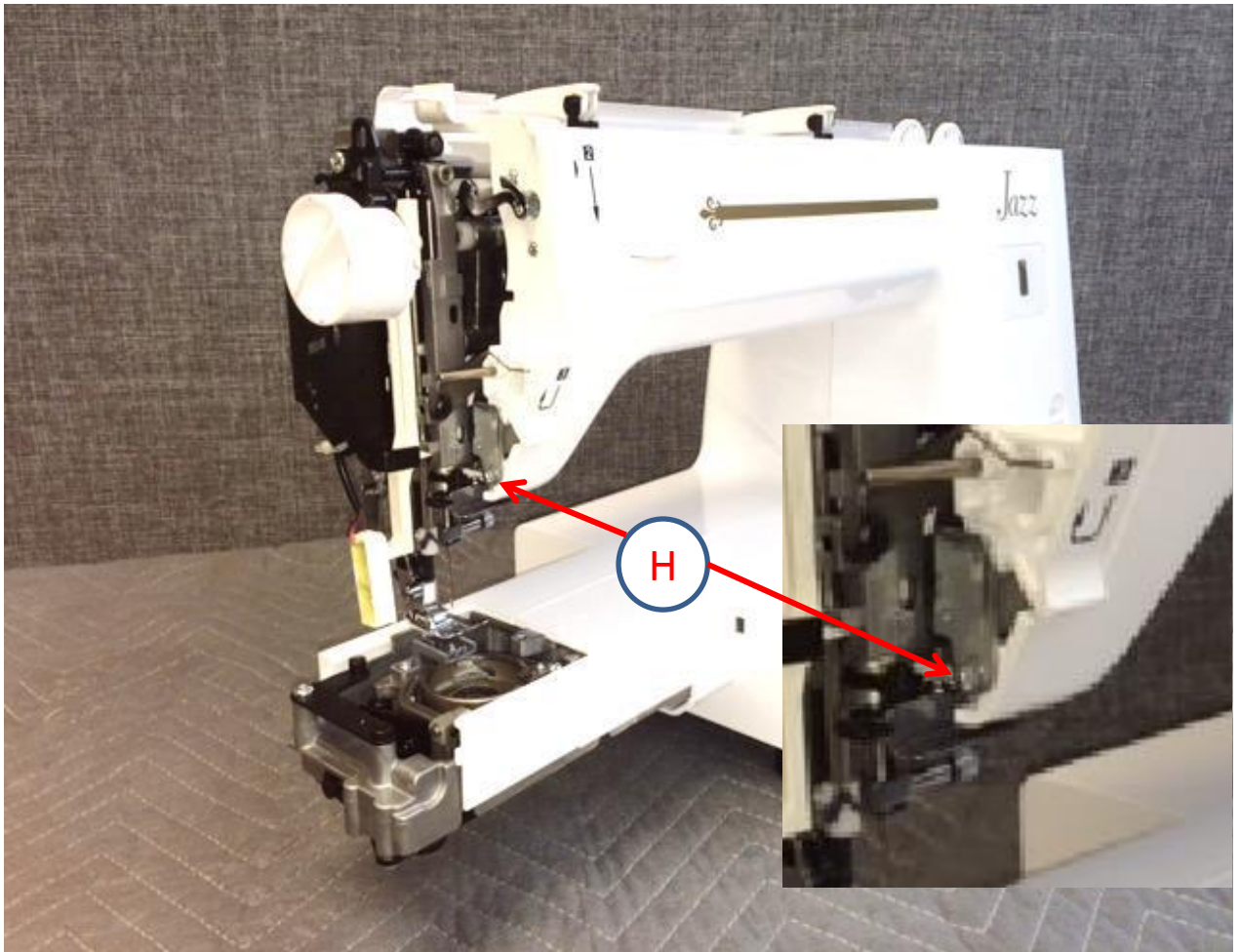

Remove screw “ H ” and take away the Front Cover.

Cover Removal (Continued)

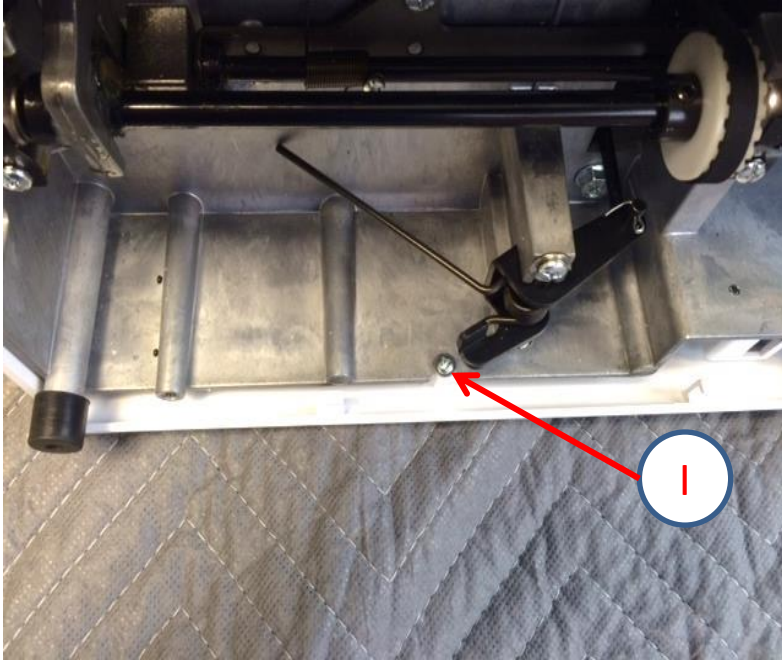

Remove screw "I" from
the Rear Cover
(On the bottom)

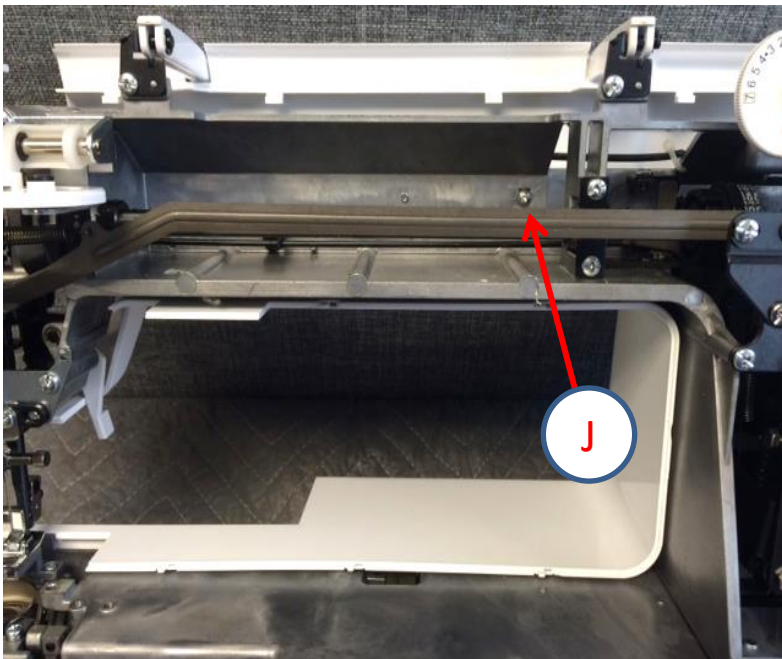

Remove screw "J",
raise handle, and
detach Rear Cover
(Above Upper Shaft)
Screw "J" is longer
than screw "I"

Presser Bar Height



After raising the presser foot lever to the up position, you should have a spacing of 6mm from the bottom of the foot, to the top of the needle plate. (A 6mm Allen wrench can be used for this)

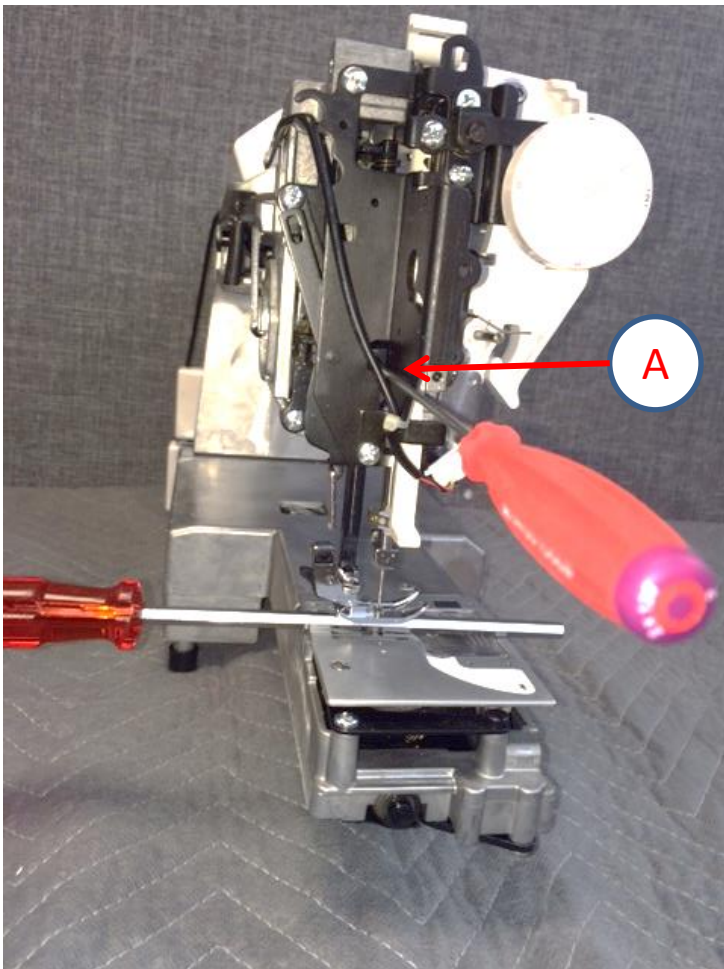

To adjust, loosen the 2mm screw, 'A' .

Make sure foot is parallel with the markings of the needle plate .

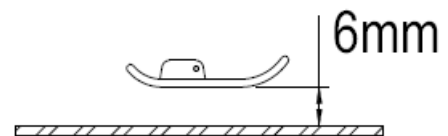

Center Needle Position

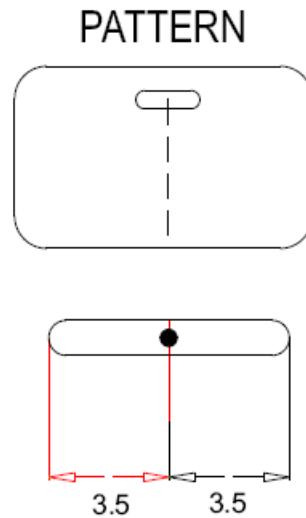
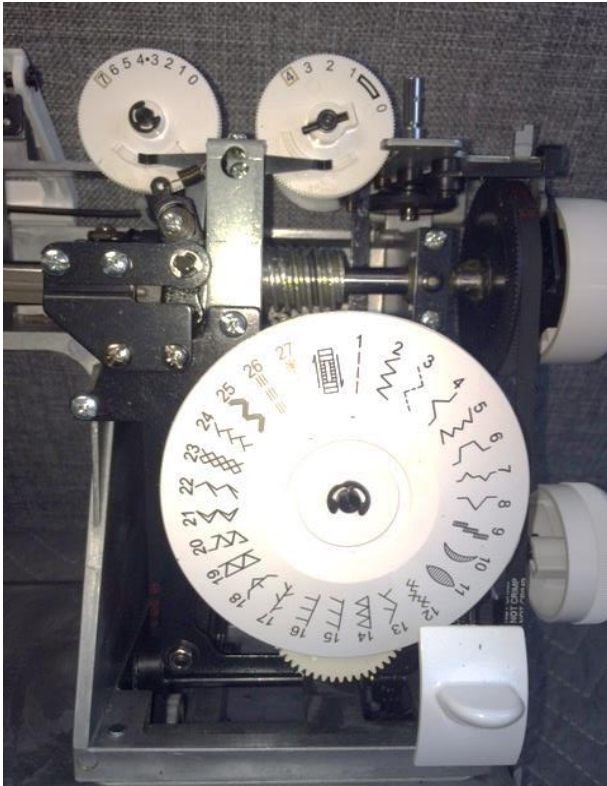

Position the machine to straight stitch, Center Needle.

To adjust, loosen screw 'B' (2mm) and rotate eccentric screw 'C'.

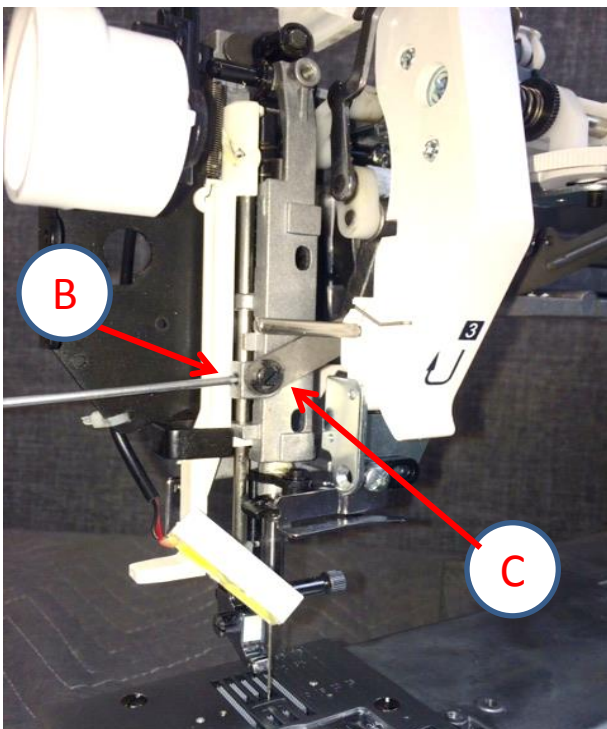

Adjustment

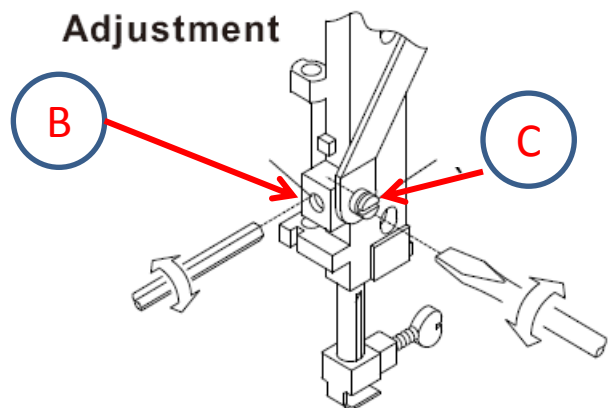

Needle Bar Height

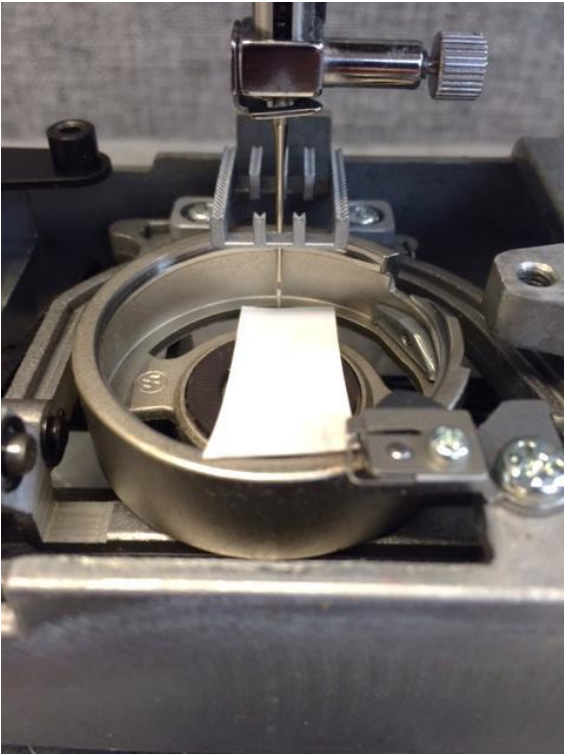

Install an HAX1 size 90 needle.

Rotate the handwheel until the needle is at its lowest position. The tip of the needle should be even with the base of the Hook.

If not, loosen 2mm screw 'D' and adjust.

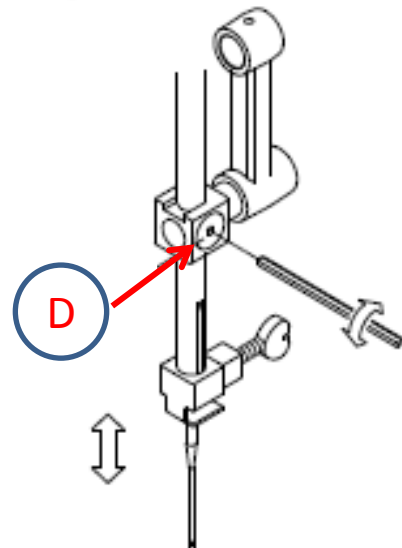
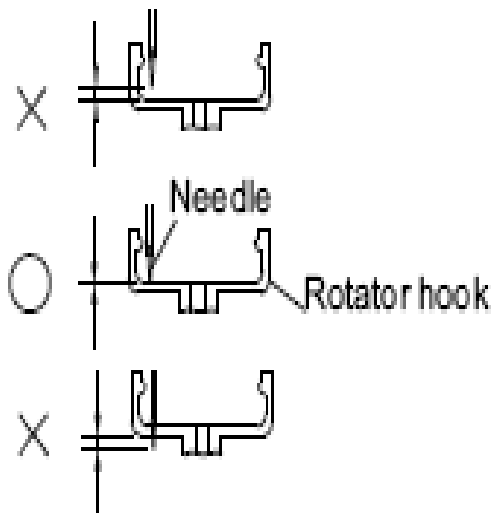

Pendulum Timing

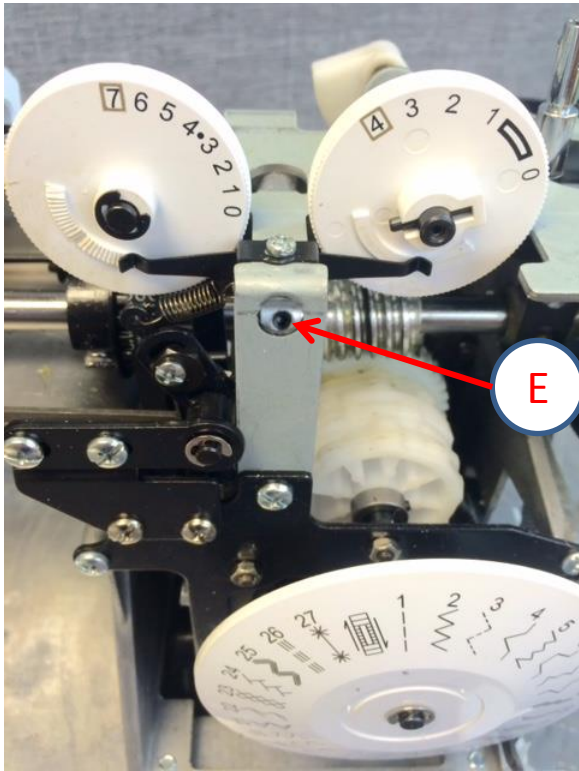

Set the machine with the widest ZZ stitch.

While the needle is rising, it should not begin to swing until it is 2–5mm above the needle plate.

To adjust, loosen 2.5mm screw 'E' and rotate the worm gear on the upper shaft.

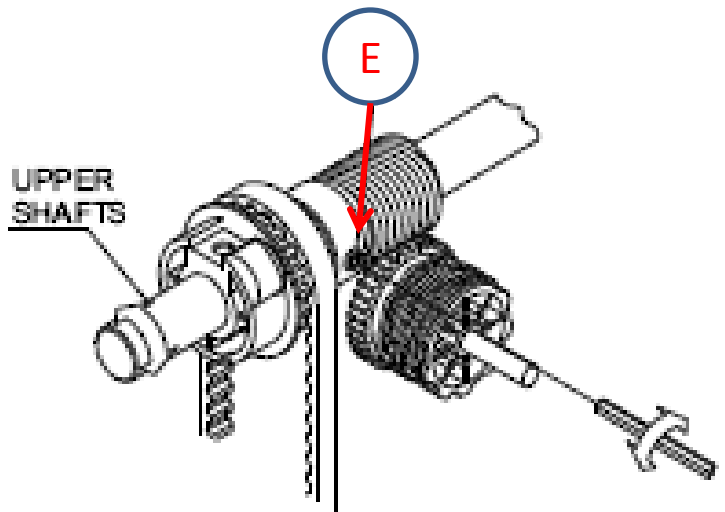
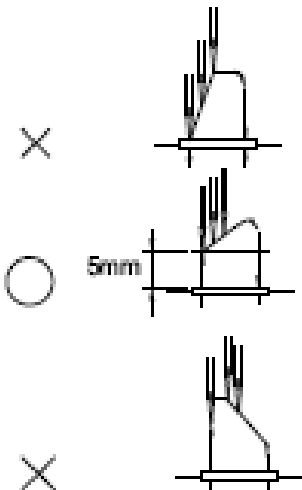

Needle Bar Z/Z Limit

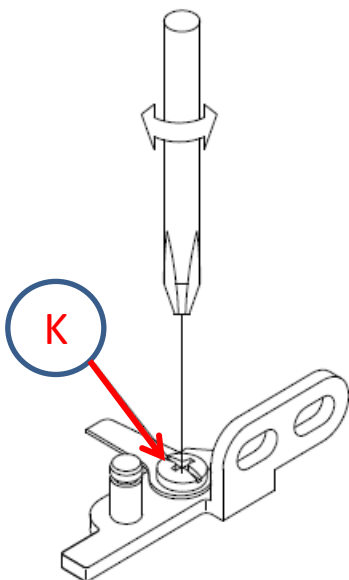
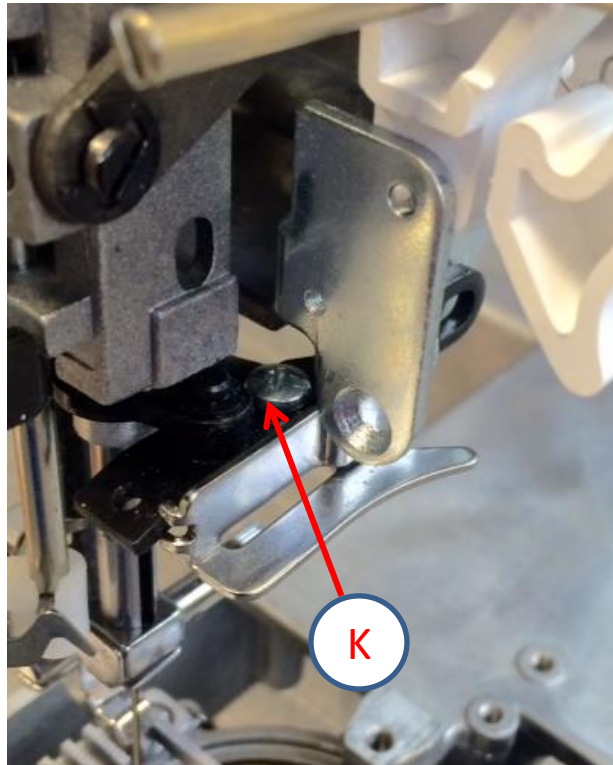
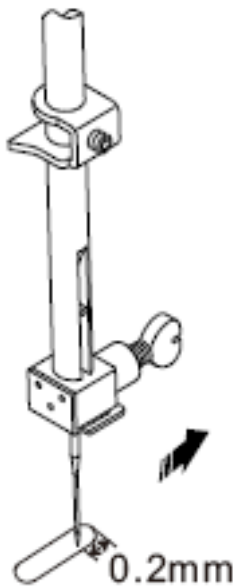

To eliminate the risk of the needle striking the needle plate while stitching widest Zig Zag, adjust the ZZ limit so that when the Needle is at far right position it misses the needle plate by 0.2mm. Loosen screw (K) and adjust.

Feed Dog Height

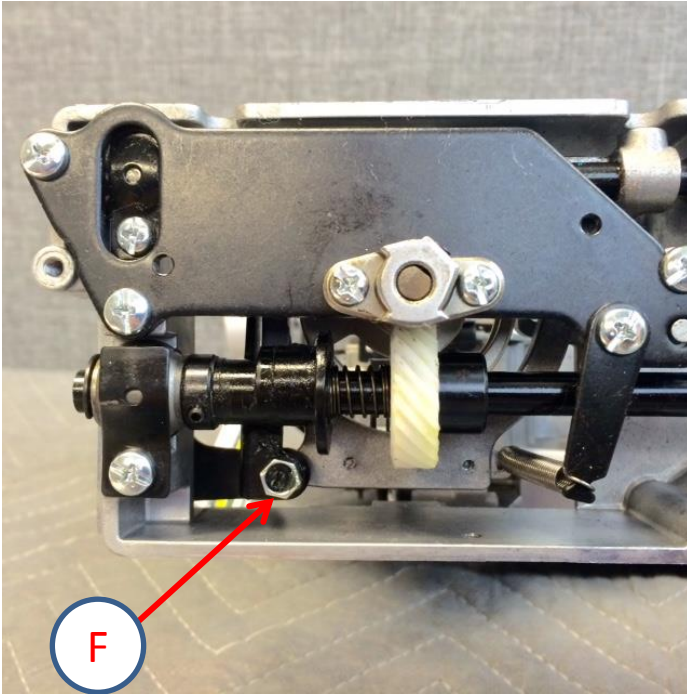

When the feed dog is in its highest position, the teeth should be 1mm above the needle plate. (Before making adjustment, be sure there is no lint built up under the needle plate)
Loosen the 7mm nut and adjust screw 'F' .

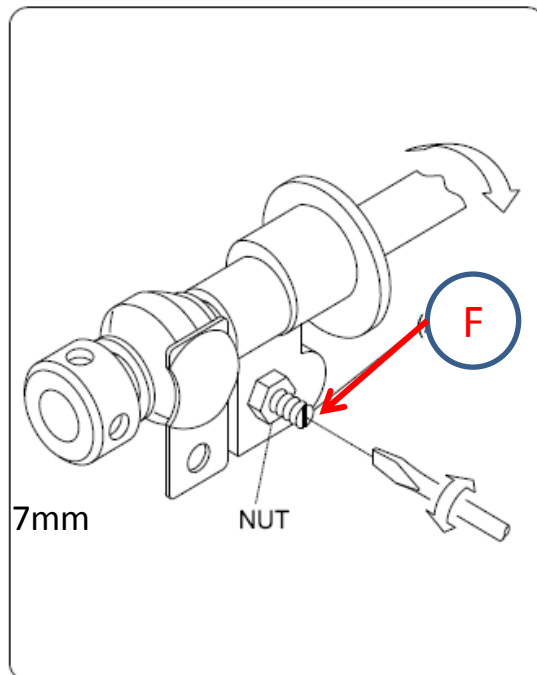
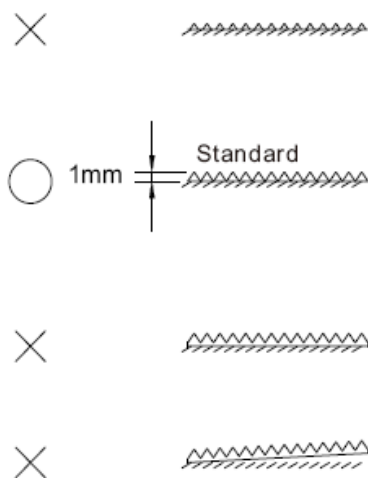

Feed Dog Block Motion

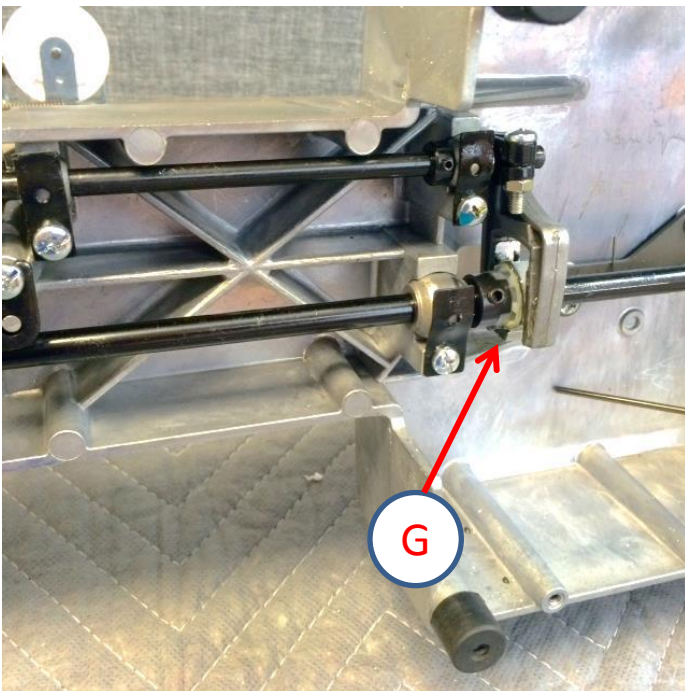
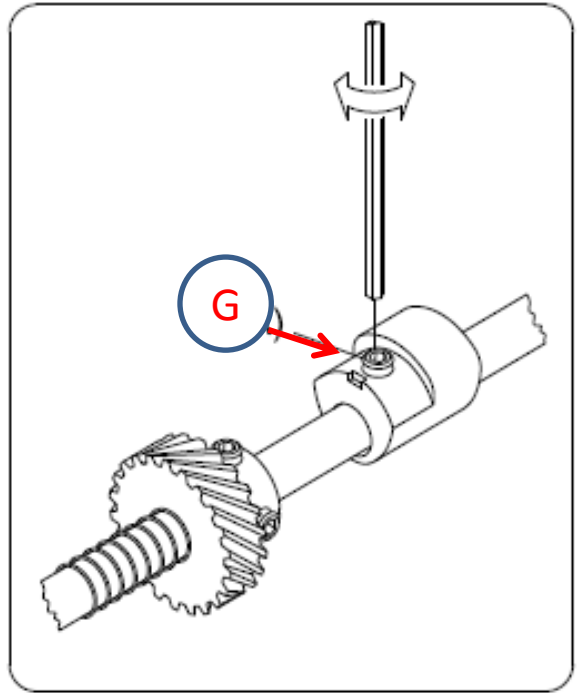
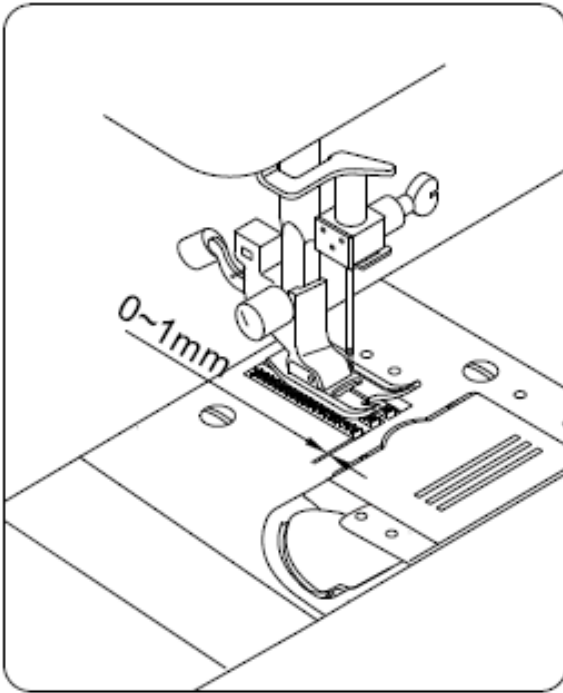

To check correct feed motion, rotate the handwheel to see that when the feed dogs are on their up stroke. They should travel to the rear, and drop when the feeding has stopped.

Loosen 2.5mm screw 'G' and rotate the cam to correct.

Hook Timing

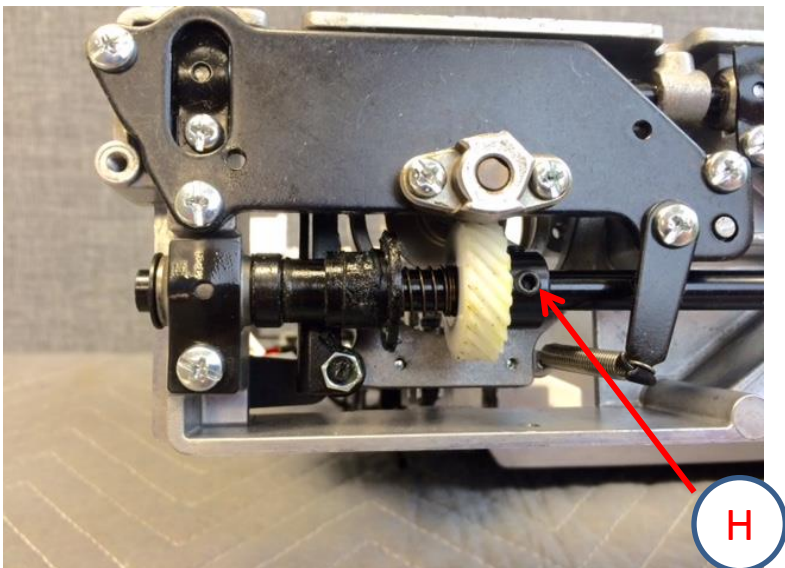
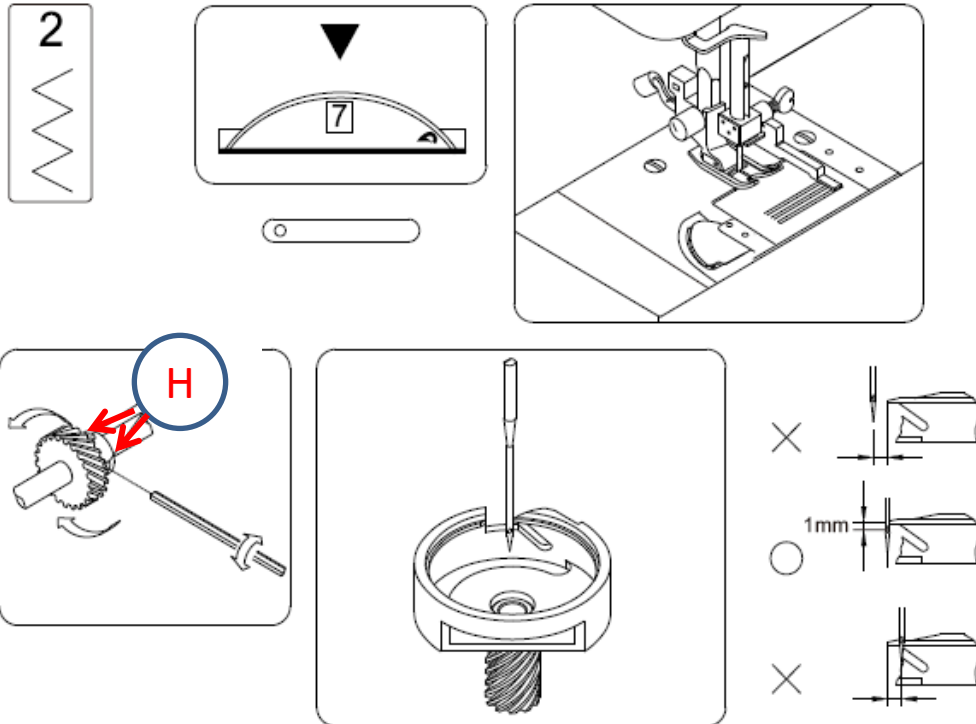

Set the machine with the widest ZZ stitch. While the needle is rising in the far left needle position, the tip of the hook should approach the needle at the lowest portion of the scarf of the needle. (1.0 mm above the needle eye) If not, loosen the two, 2.5mm lock screws and adjust.

Needle/Hook Clearance

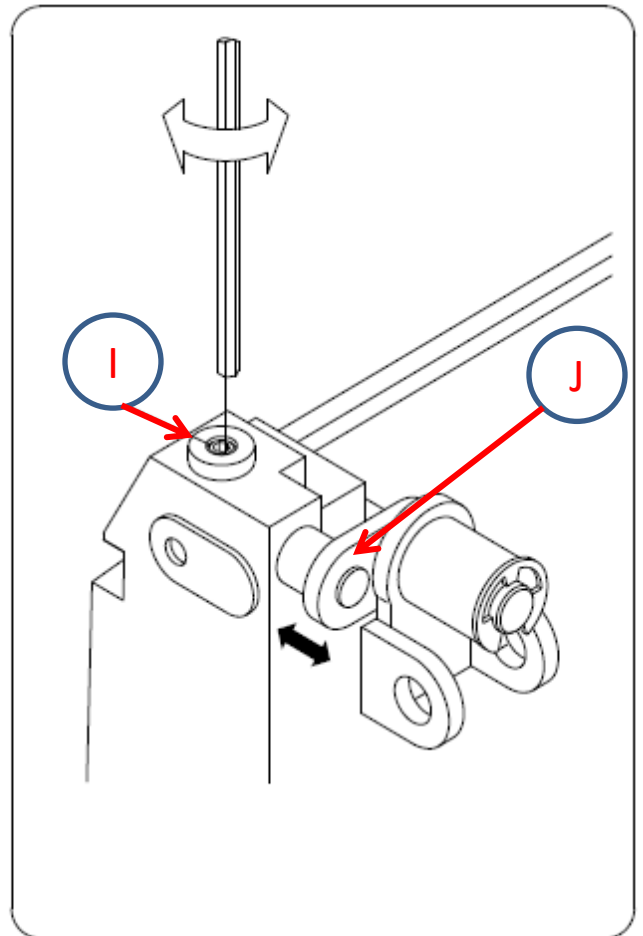
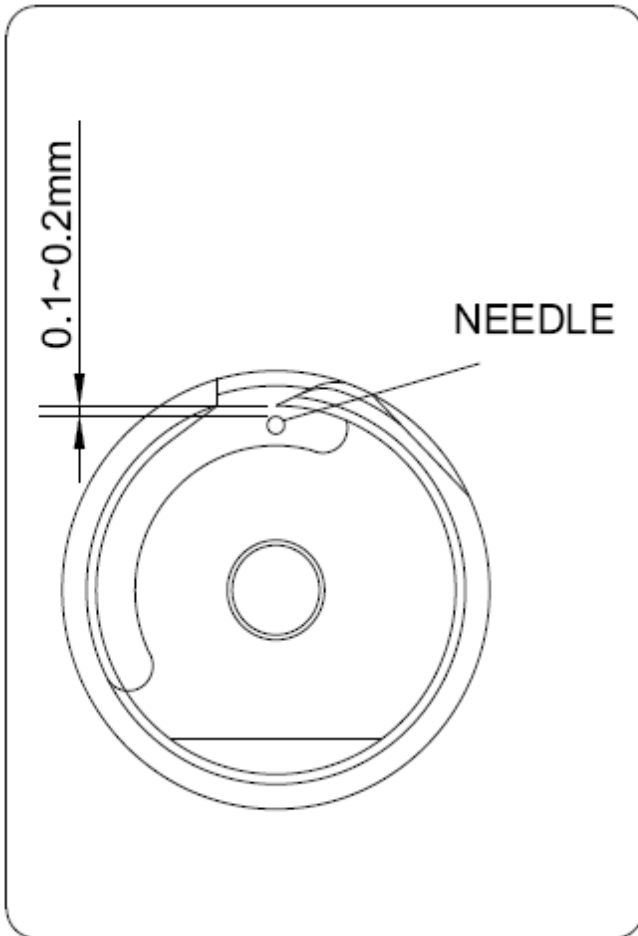

To adjust the Needle to Hook clearance, loosen the 2mm lock screw (I) and move the Upper Needle Bar Support shaft (J) . Moving it to the front will make the Clearance tighter, and moving to the back will give it more spacing

Outer Hook Replacement

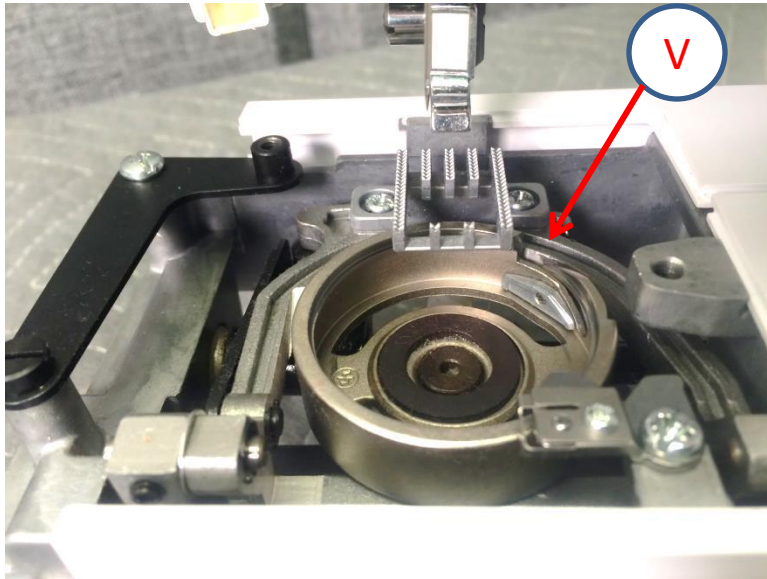

Should you need to replace the Outer Hook, first rotate the handwheel so the needle is at it's highest position. (at this time, the tip of the hook should be positioned at the 2:00 position 'V')

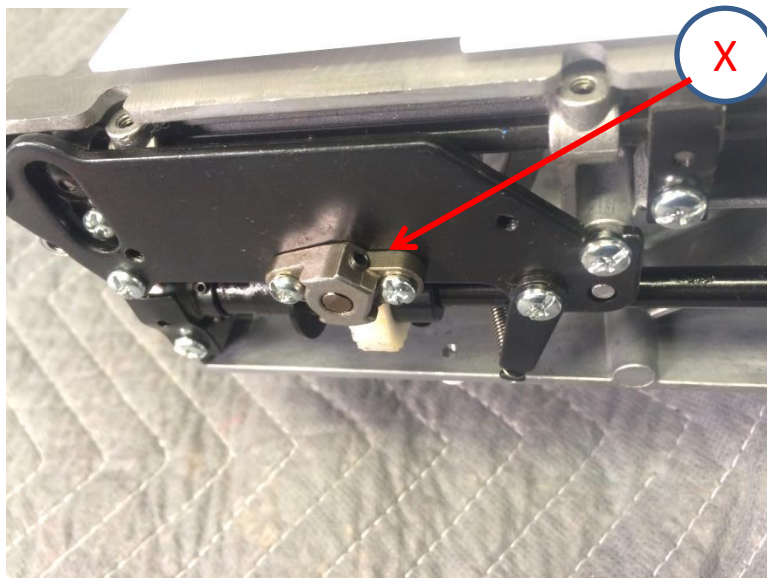

Loosen set screw 'X' , rotate the Hook counter clockwise while lifting, allow the hook to drop so you can remove the shaft..

When installing, reposition the hook, so it lands at the 2:00 position, install the shaft so there is not too much pressure, and no Up/Down play.

Note : There is a flat on the Hook shaft to follow.

Position of the Bobbin Case Stop Plates

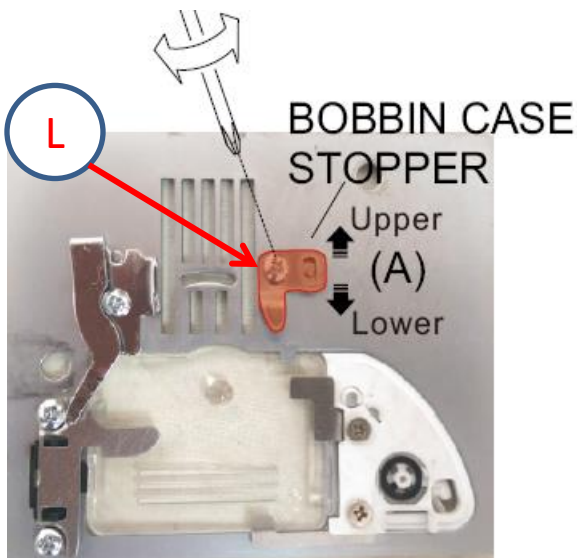
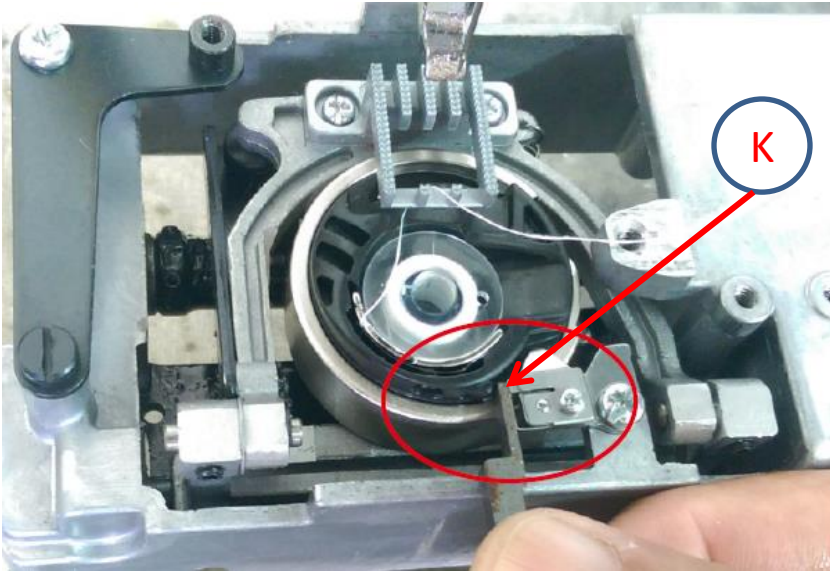

With the Needle Plate attached, you should have rotation of 1mm.

First inspect the Bobbin Case Bracket (K)

Then inspect the Bobbin Case Stopper under the needle plate (L)

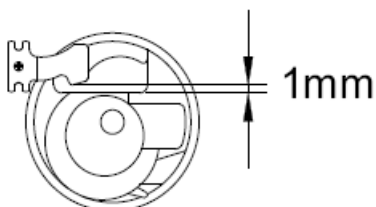

Reverse Lever Adjustment

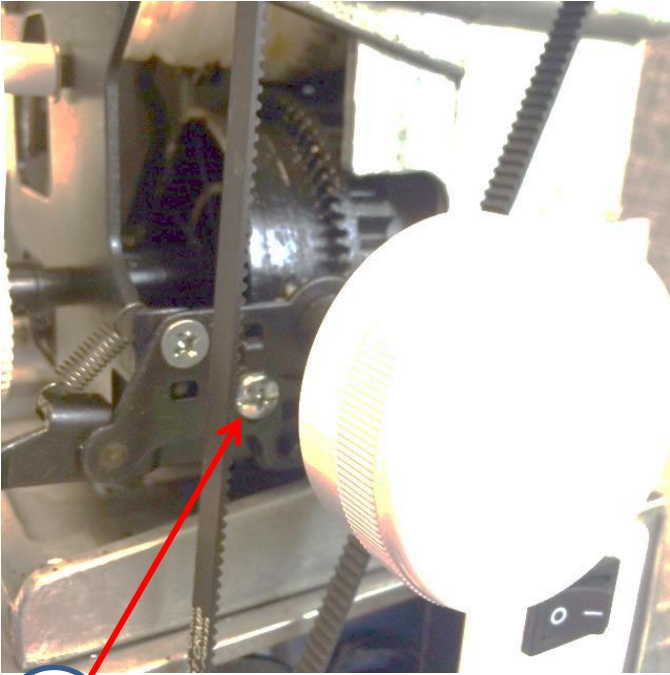

For ' More' or 'Less' Reverse feeding while, engaging the Reverse lever, loosen screw 'M' and adjust down for less Reverse, and up for more Reverse.

M

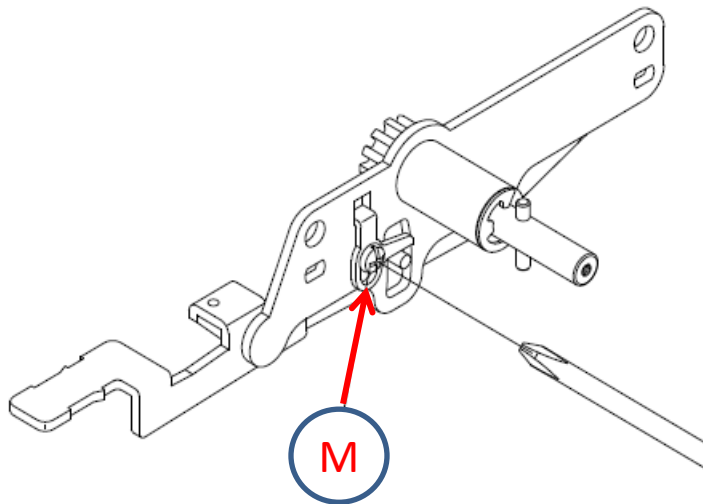

Stretch Stitch Adjustment

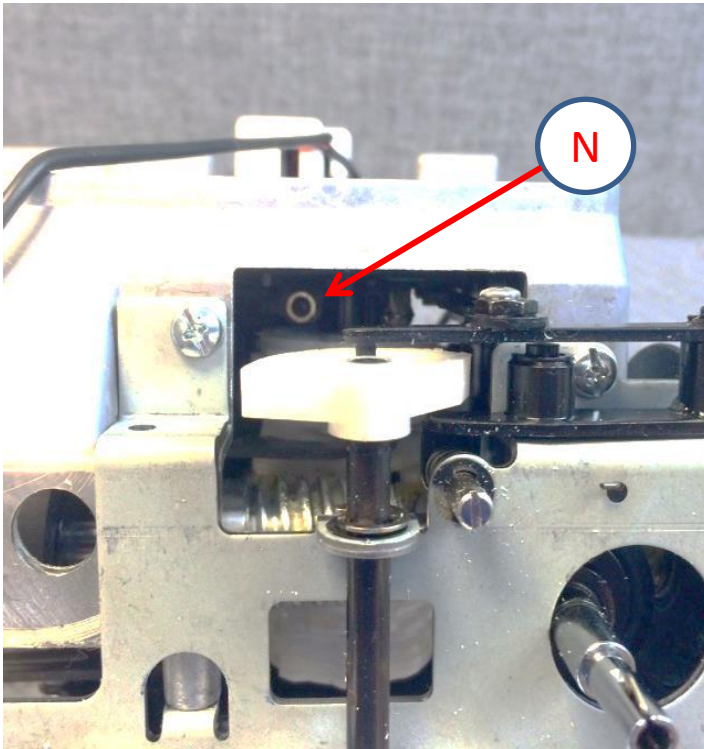

To adjust the SS, Select Pattern # 20, and set the stitch length dial to 4.

To adjust, loosen nut 'N' and adjust the screw clockwise to open the pattern and counter clockwise to close the pattern.

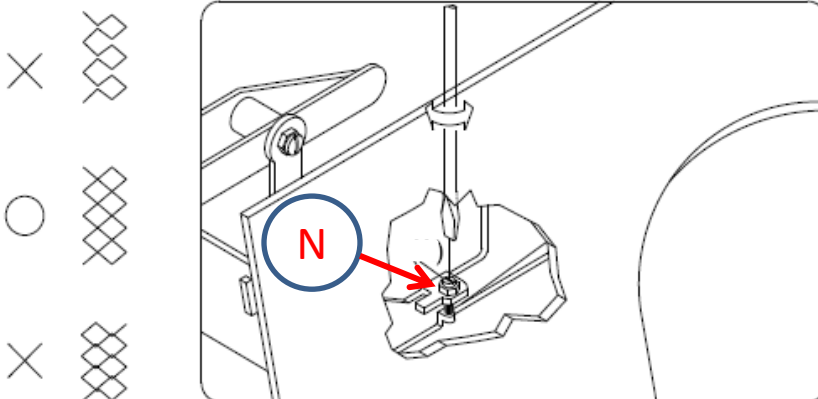

Buttonhole Bartack Density

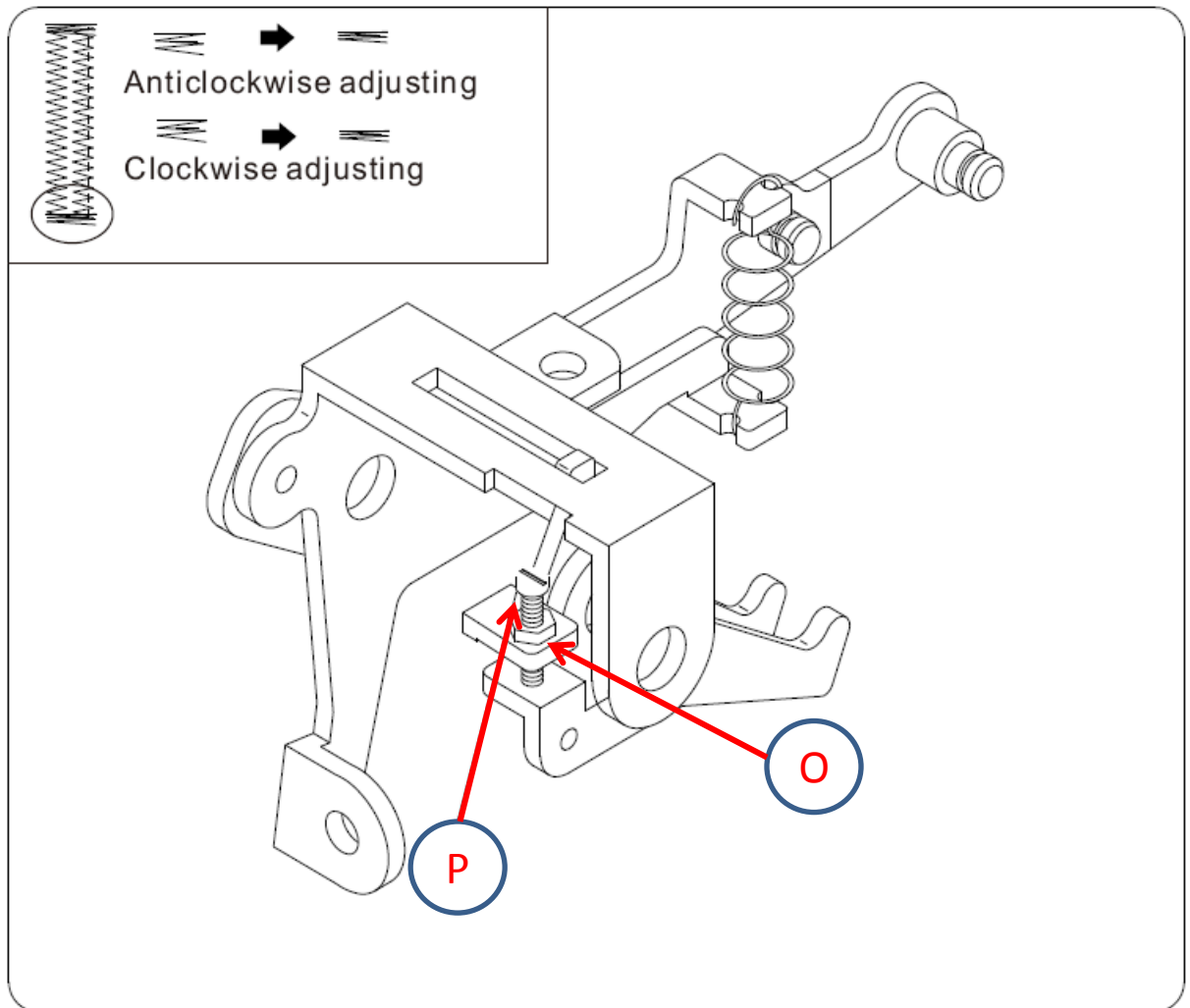

To Adjust Buttonhole Bartack Motion, first loosen 5.5mm nut (O) and adjust screw (P) accordingly. Then retighten nut (O)

Buttonhole Density Adjustment

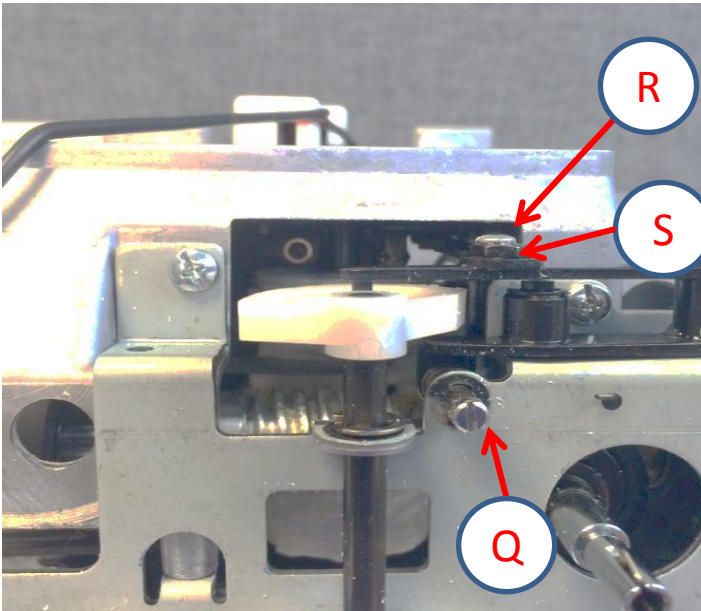

To adjust the Density of the legs, first set the Consumer-Fine tune adjustment 'Q' to the halfway position.

Then loosen The locking screw 'R' and rotate the 8mm eccentric nut 'S' .

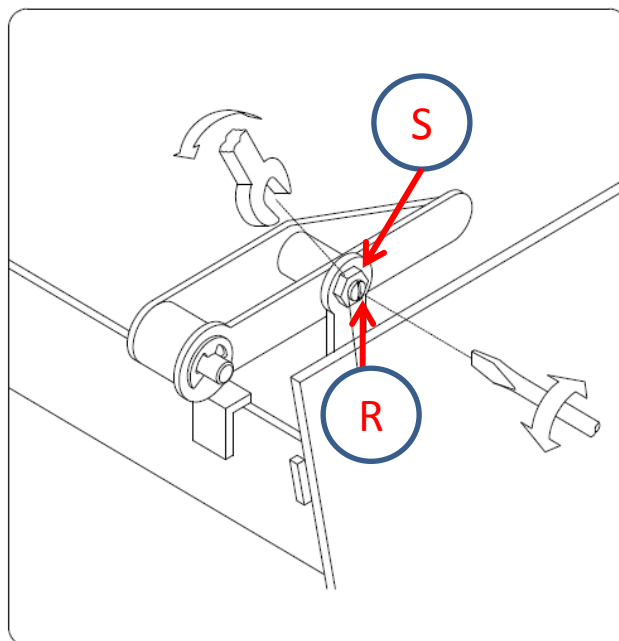
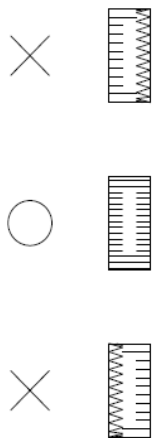

Bobbin Case Tension

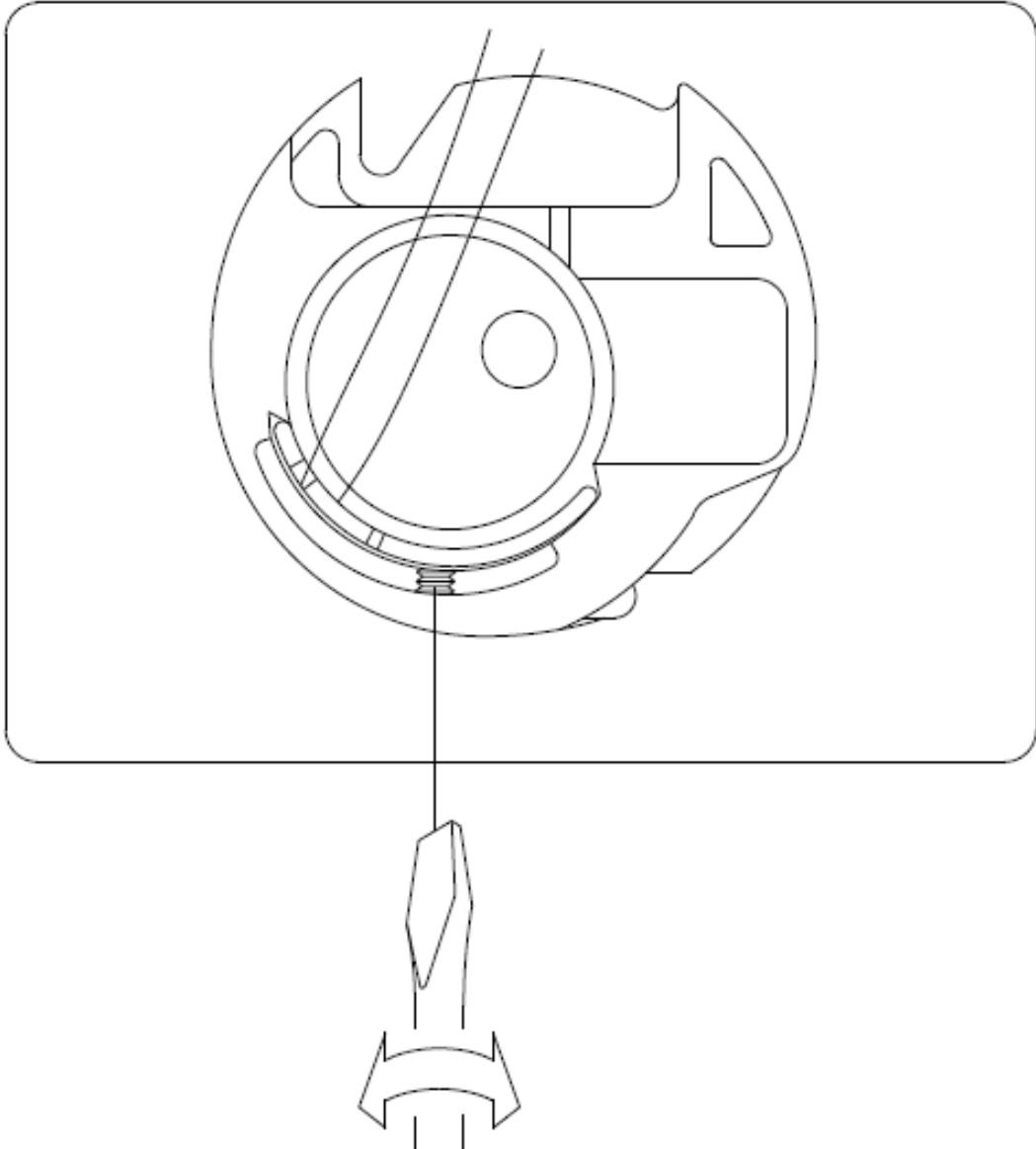

The proper tension on the Bobbin case while using a 60 weight thread and your Gram gauge should be 15-17 Grams. If not, adjust screw accordingly

Upper Thread Tension

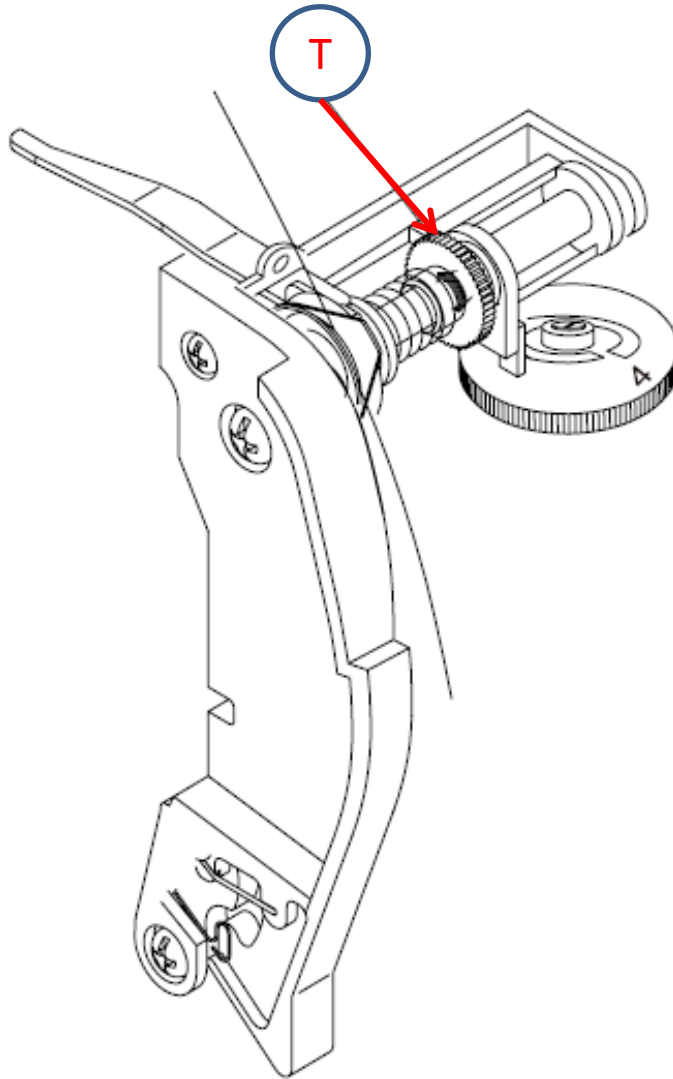

With the Tension Dial set to “4” The proper tension for the upper thread should be equal to 55-60 Grams while using a 60 weight thread attached to your Tension Gauge. If not, adjust nut ‘T’ .

Needle Threader Position

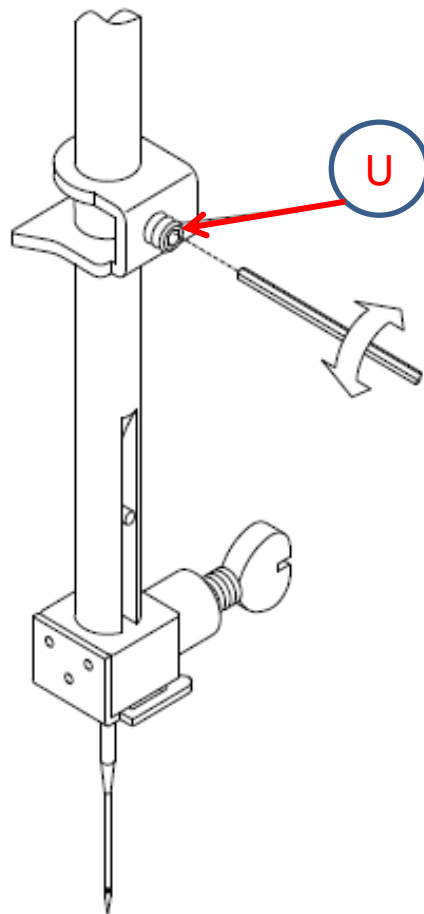

The Needle Threader works when the Needle Bar is placed in the Highest position. If the hook has been replaced and coming in too high, or too low, loosen the 1.5mm screw 'U' and adjust the Needle Threader Block up/down as needed.

Be careful to keep the screw facing forward.

