



One Strap School Bag for Midwest Mission

Sewing Instructions

Finished Size: 14" wide x 14¹/₂" tall

Suitable fabrics: denim, corduroy, sailcloth, med.-heavy drapery fabric, light upholstery; NOT double-knit.

Step 1: Cut the fabric

Use one piece of fabric 20" wide by 32" long and cut a 5" strip off of the long side for the handle (strap). **OR** Cut a piece 15" wide by 32" long for the bag, then cut a coordinating piece 5" wide and 32" long for the handle (strap).

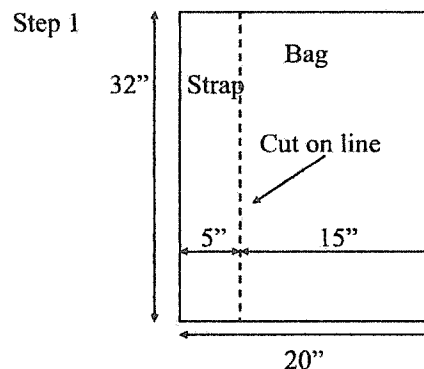

Step 2

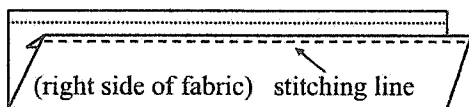

Step 2: Make the Handle (strap):

Press under 1/2" on each long side of the narrow 5" piece. Fold in half lengthwise with the right side out, and press. Sew along the long open edge of the handle.

Step 3: Make the body of the Bag:

Fold the large piece in half with the wrong side out, making a 15"x16" bag. Stitch up the side seams with a 1/2" seam then stitch again for strength. If the fabric ravels, please zig-zag the edge of the seam, too. (OR use a serger) Fold down the top of the bag 1/4" toward the outside, press in place. Fold it down another 1" and press. Stitch near the edge as shown. Turn the bag right-side-out and press.

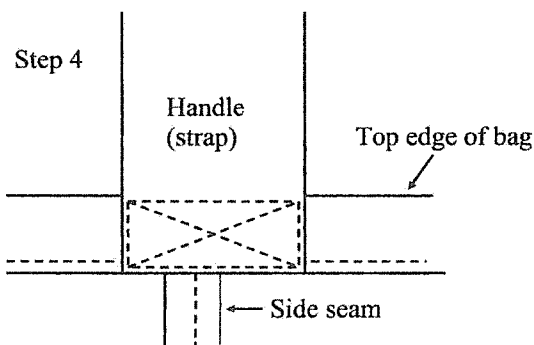
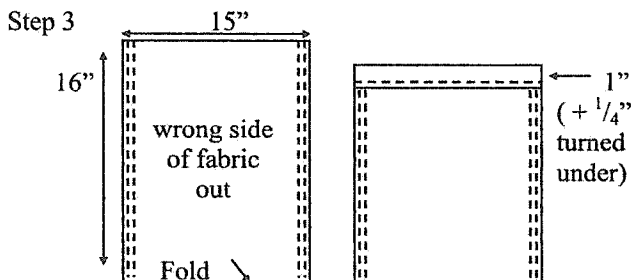

Step 4: Attach the Handle (strap):

Center the ends of the strap over the side seams, on the inside of the bag. Pin in place. Stitch a box around the edges of the strap, then sew an X to the corners of the box, as shown.