

LAARS[®]



Heating Systems Company

A subsidiary of **BRADFORD WHITE**[®] Corporation



TANKS

BUFFER, STORAGE, SOLAR AND CUSTOM

LAARS Heating Systems Company has more than 60 years experience in providing customers with advanced product solutions to commercial hydronic and hot water applications. With unrivaled commitment to design, service and support, LAARS is the preferred choice of specifying engineers, facilities managers and mechanical contractors. Headquartered in Rochester NH, USA.

THE LAARS ADVANTAGE

Laars offers an incredible variety of tanks to suit nearly every application. Our advanced manufacturing facility and highly skilled craftsmen can provide the exact tank you need.

When it comes to tanks, Laars is the only name to consider

- Bare Storage Tanks from 175 to 5,695 gallons
- Jacketed and Insulated Tanks from 240 to 1,040 gallons
- Rigid Foam with Topcoat Tanks from 240 to 1,040 gallons
- Buffer Tanks from 130 to 1,040 gallons
- Custom Tanks Built to Your Specifications
- Solar Tanks with Varied Coil Arrangements
- Factory application experts a call away
- Regional sales and service support: before, during and after installation!

PERFORMANCE PROVEN LININGS

- Glass lined - An exclusive corrosion-resistant enamel coating is bonded to the interior surfaces at 1600°F – Backed by a 5-year limited warranty.
- Double Glass lined - The glass lining process is repeated, providing a double layer of protection – Backed by a 10-year limited warranty.
- Epoxy Lined – FDA Approved, corrosion-resistant lining is field repairable, max temp 180°F, – Backed by a 1-year limited warranty.
- Stainless Steel – Tanks manufactured of 316L Stainless Steel with 316, 304L, and 304 available upon request. Thickness - 10 gauge and up – Backed by a 1-year limited warranty.

HIGH CAPACITY FURNACE

Used with our enamel (glass) linings, the furnace maintains tight temperature set-points for proper curing and fusion between the glass and the steel substrate. This large capacity furnace can process tanks up to 7' diameter x 16' long.



LAARS OFFERS MULTIPLE STYLES OF STORAGE TANKS-

BARE TANKS, JACKETED AND INSULATED TANKS AND FOAM WITH TOPCOAT TANKS

VERTICAL AND HORIZONTAL

BARE TANKS - These large-volume, bare tanks offer capacities ranging from 175 to 5,695 gallons (662 to 21,558 liters) with inventoried sizes up to 1,040 gallons (3,937 liters). Models inventoried for rapid shipment include select 30", 36", 42" and 48" standard diameters, call for availability. Horizontal and vertical configurations as well as custom sizes are available. All tanks come with red oxide shop primer exterior.

JACKETED AND INSULATED TANKS - These large-volume, insulated and jacketed tanks offer seven capacities ranging from 240 to 1,040 gallons (908 to 3,937 liters). Two inch (5cm), high-density foam insulation with R12.5 value minimizes heat loss. Tank diameters are 30", 36", 42" and 48" (add 4" to diameter to allow for insulation and jacket). All tank diameters are inventoried for rapid shipment. Samples pass UL94 Flame Class 94 HF-1.

RIGID FOAM WITH ACRYLIC TOPCOAT TANKS - The versatile rigid foam and acrylic sealant coating can be applied to any size tank in either vertical or horizontal configuration. These large volume tanks offer capacities ranging from 175 to 5,695 gallons (662 to 21,558 liters) with inventoried sizes from 240 to 1,040 gallons (662 to 3,937 liters). Inventoried diameters are 30", 36", 42" and 48" (add 4.5" to diameter to allow for foam application). The rigid foam and topcoat method of insulating hot water storage tanks provides a high R16 level of insulation at a cost lower than any other insulation type. Class I foam with less than 25-flame spread rating, suitable for boiler room applications. SPF meets California Title 24.

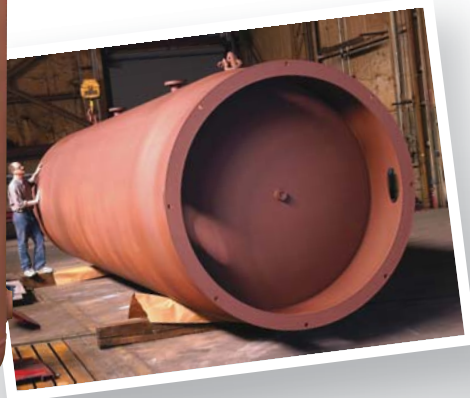

A.S.M.E. CONSTRUCTION - All tanks are A.S.M.E. code constructed and certified and are available for 125 and 150 psi (862 and 1034 kPa) working pressures.

LAARS[®]
Heating Systems Company
A subsidiary of **BRADFORD WHITE**[™] Corporation

LAARS HOT WATER STORAGE VESSELS BARE TANKS

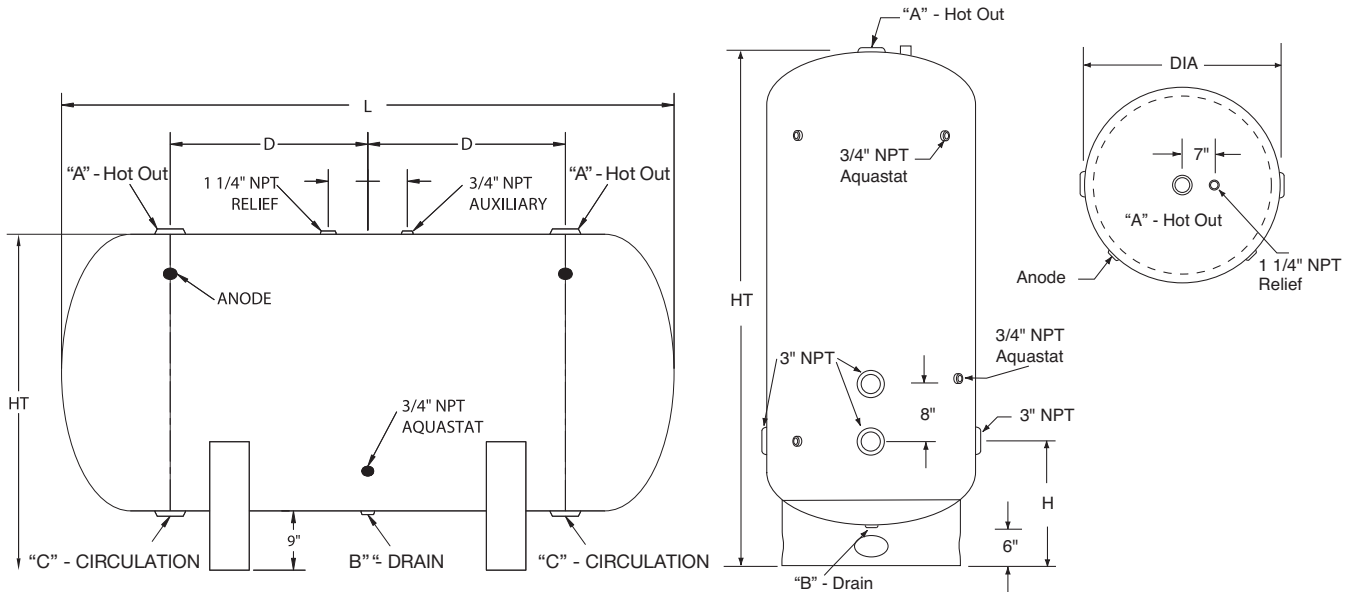

TANK MODEL TREE

Digit/Position	1	2	3	4	5	6	7	8	9	10	11	12	13	14	15	16
Reference	Product Series		Type	Lining	Insulation	Diameter		Length/Height			Manway	Hot Out Tapping	Pressure	Options	Options	Options
Values	C	T	V	G	B	X	X	X	X	X	M	X	S	X	X	X
	S		H	D	I						X	S	H			
			N	E	J											

LHSC PART No.

1-2 Product Series: CT = Custom Tank; ST = Standard Tank

3 Type: V = Vertical; H = Horizontal

4 Lining: G = Glass; D = Double Glassed 10-year; E = Epoxy; N = No Lining

5 Insulation: B = Bare Tank; I = Insulating Foam & Topcoat; J = Insulated & Steel Jacketed

6-7 Diameter

8-10 Length (or Height)

11 Manway: M = Manway; X = Less Manway

12 Tapping Size: X = Standard

S = Special Order (submit drawing indicating all tappings, use Doc. 8005)

13 Pressure Rating: S = Standard 125 psi; H = 150 psi

14-16 Contact factory for Custom Options:

Drain and Circulation Tapping Sizes,
SS Flanges 125 psi, SS Flanges 150 psi, Add'l Openings,
Extended Couplings, Inorganic Zinc and others

W-H-196 Test = 7.0 - 8.0 mg/in²

The W-H-196 Test is required for water heaters sold to the U.S. Government. The test consists of exposing the enamel to a boiling (212°F) 4/10% solution of Sodium Bicarbonate for eight (8), eighteen (18) hour cycles. Maximum weight loss after eight cycles is not to exceed 15 mg/in².

PEI T-21 Spot Acid Test = Class A

PEI T-21 Spot Acid Test is used to determine enamel resistance to acids. The test area is examined for visible effects on the enamel and is graded from Class AA (no sign of etching) to Class D (etched surface).

Impact resistance = Class 4 to 5

The Impact Resistance Test is used to determine the adhesive qualities of enamel to the substrate. The enamel is graded from Class 1 (worst) to Class 5 (best), fractured glass adhering solidly to the impact area. Class 3 is acceptable.

Hi-Pot Test Less than 20

The HYPO Test is a measurement of the continuity of the glass coating (Spark Test). Fifty (50) breakthroughs or fewer are the usual specification for HWT's.

Specifications

Model Number	Capacity				Dimensions								Tappings			Shipping Weight					
	Nominal*		Actual		Diameter		Vert. Height		Hori. Height		L		D		A	B	C	@125#			
	Gal.	L	Gal.	L	in.	cm	in.	cm	in.	cm	in.	cm	in.	cm	in.	in.	in.	in.	lbs.	kg	
CTV GB 30-063	193	731	175	662	30	762	69	1753	39	991	19.5	495	63	1600	22.5	572	2.5	1	3	612	277
CTV GB 30-075	229	867	210	795	30	762	81	2057	39	991	19.5	495	75	1905	28.5	724	2.5	1	3	651	295
CTV GB 30-085	260	984	240	908	30	762	91	2311	39	991	19.5	495	85	2159	33.5	851	2.5	1	3	703	319
CTV GB 30-099	303	1147	280	1060	30	762	105	2667	39	991	19.5	495	99	2515	40.5	1029	2.5	1	3	786	356
CTV GB 30-111	340	1287	320	1211	30	762	117	2972	39	991	19.5	495	111	2819	46.5	1181	2.5	1	3	831	377
CTV GB 36-072	318	1272	285	1079	36	914	78	198	45	1143	21	53	72	183	21	53	2.5	1	3	743	337
CTV GB 36-078	344	1302	310	1173	36	914	84	2134	45	1143	21	533	78	1981	30	762	2.5	1	3	848	385
CTV GB 36-085	375	1420	340	1287	36	914	91	2311	45	1143	21	533	85	2159	33.5	851	2.5	1	3	836	379
CTV GB 36-090	397	1503	360	1363	36	914	96	2438	45	1143	21	533	90	2286	36	914	2.5	1	3	941	427
CTV GB 36-102	449	1700	415	1571	36	914	108	2743	45	1143	21	533	102	2591	42	1067	2.5	1	3	992	450
CTV GB 36-114	502	1900	465	1760	36	914	120	3048	45	1143	21	533	114	2896	48	1219	2.5	1	3	1145	519
CTV GB 36-126	555	2101	515	1949	36	914	132	3353	45	1143	21	533	126	3200	54	1372	2.5	1	3	1186	538
CTV GB 42-081	486	1840	435	1647	42	1067	87	2210	51	1295	22.5	572	81	2057	31.5	800	3	1	3	996	452
CTV GB 42-085	504	1931	460	1741	42	1067	91	2311	51	1295	22.5	572	85	2159	33.5	851	3	1	3	1081	490
CTV GB 42-093	558	2112	505	1912	42	1067	99	2515	51	1295	22.5	572	93	2362	37.5	953	3	1	3	1068	484
CTV GB 42-105	630	2385	575	2177	42	1067	111	2819	51	1295	22.5	572	105	2667	43.5	1105	3	1	3	1210	549
CTV GB 42-117	702	2657	645	2442	42	1067	123	3124	51	1295	22.5	572	117	2972	49.5	1257	3	1	3	1370	621
CTV GB 42-129	774	2930	720	2725	42	1067	135	3429	51	1295	22.5	572	129	3277	55.5	1410	3	1	3	1520	689
CTV GB 42-139	846	3202	790	2990	42	1067	145	3683	51	1295	22.5	572	139	3531	61.5	1562	3	1	3	1798	816
CTV GB 43-073	572	2165	500	1893	48	1219	79	2007	57	1448	24	610	73	1854	27.5	699	3	1	3	1038	471
CTV GB 43-084	658	2491	580	2196	48	1219	90	2286	57	1448	24	610	84	2134	33	838	3	1	3	1161	527
CTV GB 43-096	752	2847	675	2555	48	1219	102	2591	57	1448	24	610	96	2438	39	991	3	1	3	1298	589
CTV GB 43-108	846	3202	765	2896	48	1219	114	2896	57	1448	24	610	108	2743	45	1143	3	1	3	1686	765
CTV GB 43-120	940	3558	860	3255	48	1219	126	3200	57	1448	24	610	120	3048	51	1295	3	1	3	1567	711
CTV GB 43-141	1128	4270	1040	3937	48	1219	147	3734	57	1448	24	610	141	3581	63	1600	3	1	3	2096	951
CTV GB 43-168	1316	4944	1135	4637	48	1219	168	4420	57	1448	24	610	168	4287	75	1905	3	1	3	2755	1250
CTV GB 54-099	981	3713	875	3312	54	1372	105	2667	63	1600	25.5	648	99	2515	37.5	953	2.5	1.5	3	1996	905
CTV GB 54-123	1219	4614	1110	4202	54	1372	129	3277	63	1600	25.5	648	123	3124	49.5	1257	2.5	1.5	3	1989	902
CTV GB 54-147	1457	5515	1340	5072	54	1372	153	3886	63	1600	25.5	648	147	3734	61.5	1562	2.5	1.5	3	2282	1035
CTV GB 54-183	1814	6867	1690	6397	54	1372	189	4801	63	1600	25.5	648	183	4648	79.5	2019	2.5	1.5	3	2722	1235
CTV GB 60-114	1395	5281	1245	4713	60	1524	120	3048	69	1753	27	686	114	2896	45	1143	2.5	1.5	3	2399	1088
CTV GB 60-138	1689	6394	1530	5792	60	1524	144	3658	69	1753	27	686	138	3505	57	1448	2.5	1.5	3	2804	945
CTV GB 60-168	1983	7506	1820	6889	60	1524	168	4267	69	1753	27	686	168	4267	69	1753	2.5	1.5	3	3210	1456
CTV GB 60-186	2276	8616	2105	7968	60	1524	192	4877	69	1753	27	686	186	4724	81	2057	2.5	1.5	3	3616	1640
CTV GB 60-210	2570	9728	2395	9066	60	1524	216	5486	69	1753	27	686	210	5334	93	2362	2.5	1.5	3	4022	1824
CTV GB 72-120	2115	8006	1865	7060	72	1829	126	3200	81	2057	30	762	120	3048	48	1219	2.5	1.5	3	3100	1406
CTV GB 72-144	2538	9607	2285	8650	72	1829	150	3810	81	2057	30	762	144	3658	60	1524	2.5	1.5	3	3463	1571
CTV GB 72-168	2961	11209	2700	10221	72	1829	174	4420	81	2057	30	762	168	4267	72	1829	3	1.5	3	3951	1792
CTV GB 72-192	3384	12810	3115	11792	72	1829	198	5029	81	2057	30	762	192	4877	84	2134	3	1.5	3	4438	2013
CTV GB 72-216	3807	14411	3530	13362	72	1829	222	5639	81	2057	30	762	216	5486	94.5	2400	3	1.5	3	4925	2234
CTV GB 72-250	4406	16678	4120	15596	72	1829	256	6502	81	2057	30	762	250	6350	113	2870	3	1.5	3	5616	2547
CTV GB 84-138	3310	12530	2915	11034	84	2134	144	3658	93	2362	33	838	138	3505	57	1448	3	1.5	3	4747	2153
CTV GB 84-162	3886	14710	3480	13173	84	2134	168	4267	93	2362	33	838	160	4064	69	1753	3	1.5	3	5428	2462
CTV GB 84-186	4462	16890	4045	15312	84	2134	192	4877	93	2362	33	838	186	4724	81	2057	3	1.5	3	6109	2771
CTV GB 84-210	5038	19071	4610	17451	84	2134	216	5486	93	2362	33	838	210	5334	93	2362	3	1.5	3	6789	3079
CTV GB 84-256	6141	23246	5695	21558	84	2134	262	6655	93	2362	33	838	256	6502	116	2946	3	1.5	3	8094	3671

* Nominal gallon capacity is listed for comparison purposes. Nominal gallon capacity refers to a hypothetical measurement in a case where overall tank length remains the same but instead of an elliptical head and base, the gallons are calculated as if it was built with flat heads and base (see diagram).

* Nominal capacity includes the white area in addition to actual tank capacity.

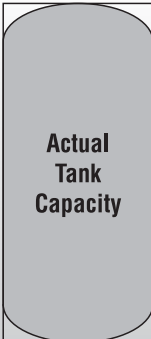

Laars Heating Systems Company reserves the right to change specifications, components, features, or to discontinue products without notice. Reference submittal documentation for most up to date information.

LAARS HOT WATER STORAGE VESSELS JACKETED AND INSULATED

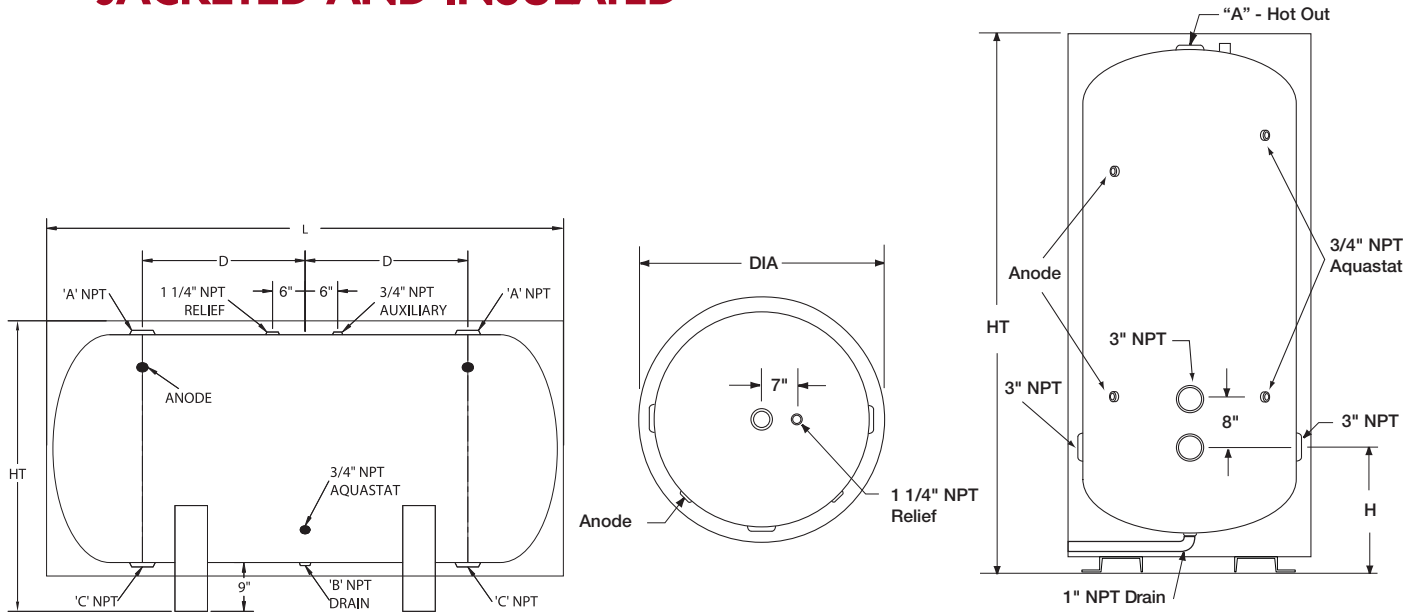

Specifications

Model Number	Capacity				Dimensions									Tappings			Shipping Weight @ 125 psi	
	Nominal		Actual		Diameter		Height Vert.		Height Horiz.		B	D	L	A	B	C	lbs	kg
	Gal.	L	Gal.	L	in	cm	in	cm	in	cm	in	in	in	NPT	NPT	NPT		
CTVG J 30-085	260	984	240	909	34	86	91	231	41	104	19.5	29	89	2.5	1	3	960	435
CTVG J 36-078	344	1302	310	1173	40	101	84	213	47	119	21	24	82	2.5	1	3	1010	458
CTVG J 36-085	375	1419	340	1287	40	101	91	231	47	104	21	27.5	89	2.5	1	3	1144	519
CTVG J 42-085	504	1907	453	1715	46	116	87	221	53	134	22.5	25.5	88	3	1	3	1074	487
CTVG J 42-093	558	2112	505	1911	46	116	91	231	53	134	22.5	30	97	3	1	3	1168	530
CTVG J 48-108	846	3202	765	2896	52	132	114	289	59	150	24	36	112	3	1	3	1803	819
CTVG J 48-141	1128	4270	1040	3937	52	132	147	373	59	150	24	52.5	145	3	1	3	2216	1005

NOTE: Base clearance is 2" on vertical tanks

TANK MODEL TREE

Digit/Position	1	2	3	4	5	6	7	8	9	10	11	12	13	14	15	16
Reference	Product Series		Type	Lining	Insulation	Diameter		Length/Height			Manway	Tapping	Pressure	Options	Options	Options
Values	C	T	V H	G D E N I	B I J	X	X	X	X	X	M X	A B C S	S H	X	X	X

LHSC PART No.

- 1-2 Product Series: CT = Custom Tank
- 3 Type: V = Vertical; H = Horizontal
- 4 Lining: G = Glass; D = Double Glassed 10-year; E = Epoxy
N = None; I = Other (Contact Factory)
- 5 Insulation: B = Bare Tank; I = Insulating Foam & Topcoat;
J = Insulated & Steel Jacketed
- 6-7 Diameter
- 8-10 Length (or Height)
- 11 Manway: M = Manway; X = Less Manway
- 12 Tapping Size: A = 2.0"; B = 2.5"; C = 3.0"
S = Special Order (submit drawing indicating all tappings, use Doc. 8005)
- 13 Pressure Rating: S = Standard 125 psi; H = 150 psi
- 14-16 Contact factory for Custom Options:
Drain and Circulation Tapping Sizes,
SS Flanges 125 psi, SS Flanges 150 psi, Add'l Openings,
Extended Couplings, Inorganic Zinc and others

LAARS HOT WATER STORAGE TANKS WITH SPRAYED-ON RIGID POLYURETHANE FOAM (SPF) WITH ACRYLIC TOP-COAT

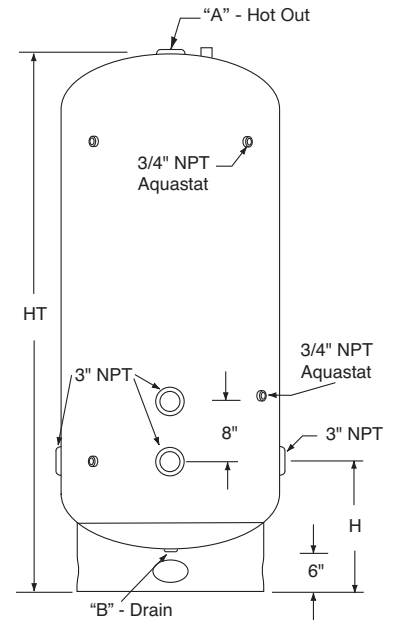
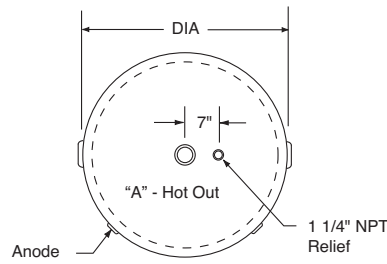
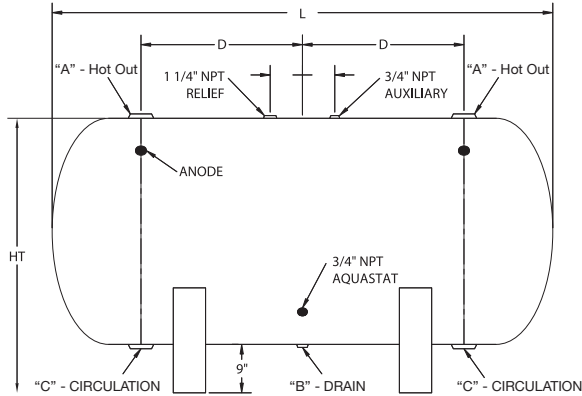

Specifications

Model Number	Capacity				Dimensions								Tappings			Shipping Weight					
	Nominal* Gal.	L	Actual Gal.	L	Diameter Gal.	L	Vert. Height in.	cm	Hori. Height in.	cm	H in.	cm	D in.	cm	A in.	B in.	C in.	@125# lbs.	kg		
CTV GI 30-085	260	984	240	909	30	76	91	231	39	99	19.5	50	85	216	33.5	85	2 1/2	1	3	763	346
CTV GI 36-078	344	1302	310	1173	36	91	84	213	45	114	21	53	78	198	30	76	2 1/2	1	3	914	415
CTV GI 36-085	375	1420	340	1287	36	91	91	231	45	114	21	53	85	216	33.5	85	2 1/2	1	3	908	412
CTV GI 42-085	510	1931	460	1741	42	107	91	231	51	130	22.5	57	85	216	33.5	85	3	1	3	1164	528
CTV GI 48-073	572	2165	500	1893	48	122	79	201	57	145	24	61	73	185	27.5	70	3	1	3	1166	529
CTV GI 48-108	846	3202	765	2896	48	122	114	290	57	145	24	61	108	274	45	114	3	1	3	1806	819
CTV GI 48-141	1128	4270	1040	3937	48	122	147	373	57	145	24	61	141	358	63	160	3	1	3	2250	1021

Note: Dimensions are for steel tank only. Application of coating will increase dimensions approximately as follows:

Vertical Ht.	2.25"	(57mm)	Horizontal Ht.	2.25"	(57mm)
Horizontal L.	4.5"	(114mm)	Vertical Dia.	4.5"	(114mm)

Spray Polyurethane Foam:

Specific Gravity:	1.17 – 1.19
Viscosity:	800 – 1300
Density:	@ 2" 2.10 – 2.35 @ 4" 1.88 – 1.99
Closed Cell Content:	>90%
K-Factor, Initial:	0.155 – 0.170
Permeance:	2.91 (perms) 2.99 (perm inch)
Dimensional Stability:	+3.3 to +8.2 - Dry Age 28 days (158°F, Dry) -0.37 to -0.96 - Freeze 14 day (-20°F)
Flame Spread:	25 - ASTM E-84
Smoke Development:	450
R Value:	7.2/ inch
Max. Thickness:	4"

Acrylic Coating:

Topcoat:	Coated white
Texture:	Smooth
Grade:	Spray or Roll
Base:	100% Acrylic
Solids by Weight:	66% (± 3)
Solids by Volume:	55% (± 3)
Weight per Gallon:	11.65 (± .2)
Tensile Strength:	300 psi (± 25)
Elongation:	260% (± 25)
Durometer Hardness:	62 Shore A (± 2)
Tear Resistance:	85 lbs/ in
Permeance:	11 U.S. Perms @ 20 mil
Viscosity:	110 K.U. (± 8)
Codes/ Approvals:	Energy Star, ICC, UL, ASTM D6083
Reflectivity:	New 85%, Aged 78%
Emmissivity:	.89

LAARS CHILLED WATER BUFFER TANKS

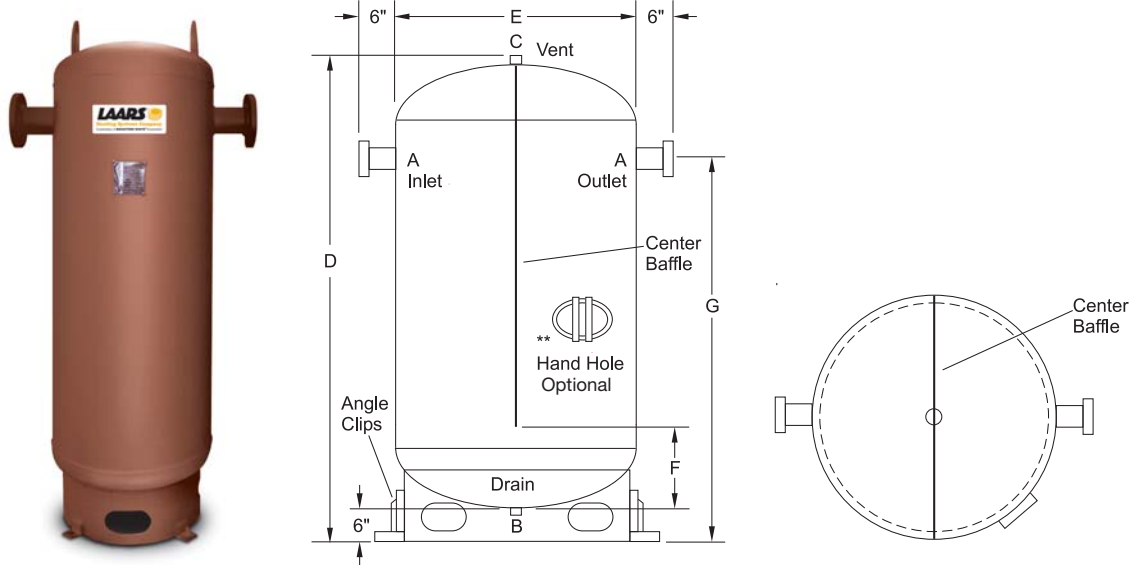

Specifications

Model Number	Capacity		A		B		C		D		E		F		G		Approx. Weight Lbs.	
			Inlet/Outlet		Drain		Vent		Floor to Top of Heater		Jacket Diameter							
	Gal.	Liters	in.	cm.	in.	cm.	in.	cm.	in.	cm.	in.	cm.	in.	cm.	in.	cm.	Lbs.	Kg.
BT VNB 24 072 XASX XX	130	492	2 NPT	5	1	2	1	2	78	198	24	61	20	51	66	168	375	170
BT VNB 30 077 XFSX XX	210	795	3 FLG	8	1	2	1	2	83	211	30	76	24	61	67	171	425	193
BT VNB 36 072 XFSX XX	300	1135	4 FLG	10	1	2	1	2	78	198	36	91	24	61	62	158	633	287
BT VNB 36 094 XFSX XX	400	1514	4 FLG	10	1	2	1	2	100	254	36	91	30	76	84	214	715	324
BT VNB 42 085 XFSX XX	460	1741	4 FLG	10	1	2	1	2	91	232	42	107	30	76	74	120	870	395
BT VNB 48 077 MFSX XX	528	1998	6 FLG	15	1	2	1	2	83	211	48	122	31	79	62	158	1150	522
BT VNB 48 141 MFSX XX	1040	3785	6 FLG	15	1	2	1	2	150	381	48	122	45	115	127	323	1975	896
BT VNB 54 096 MFSX XX	850	3217	6 FLG	15	1	2	1	2	102	259	54	137	32	81	80	204	1630	739
BT VNB 60 096 MFSX XX	1040	3936	8 FLG	20	1	2	1	2	102	259	60	152	32	81	77	196	2280	1034

**Optional hand hole and man ways are available on request.
Designed to ASME code.

LAARS® CHILLED WATER BUFFER TANKS

Laars® Chilled Water Buffer Tanks are designed to increase water volume capacity, in relation to the chiller capacity. Low water volume systems may require additional buffer capacity to eliminate excessive chiller cycling, poor temperature control or erratic system operation. These tanks increase the capacity of a chilled water system and help stabilize the return water temperature. This results in fewer cycles of the compressor and better temperature control. Between three and ten gallons of total capacity in the system per nominal ton is recommended, depending on the accuracy of temperature control required. Five gallons per nominal ton is recommended for a typical air conditioning system.

- All tanks are constructed and certified in accordance with ASME section VIII, Div. I code
- Red oxide shop primer exterior
- Spray foam insulation available, R-16 value and acrylic top coat
- Custom sizes available upon request
- Can be ordered in vertical or horizontal orientation

LAARS LARGE VOLUME SOLAR TANKS

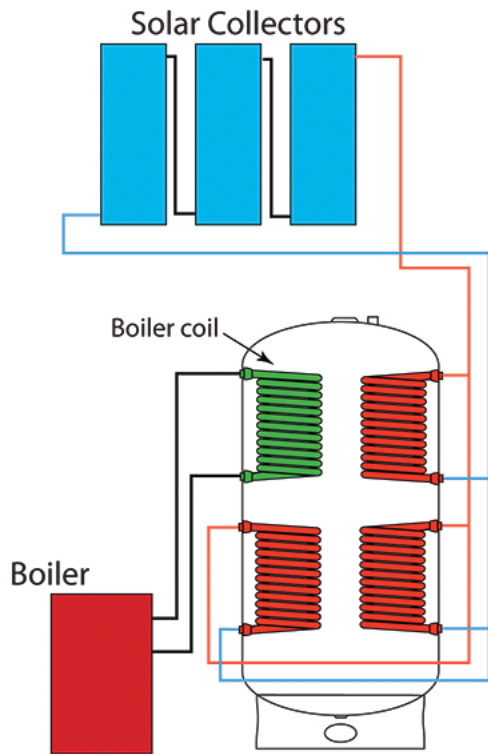

Solar Tank, collectors with a back-up boiler - typical configuration.

MULTIPLE APPLICATION USE

Laars Heating Systems offers solar tanks as an alternative heating source that will save you money and energy for many years. These solar tanks come in many sizes, input coil arrangements and tapping configurations in order to match your application requirements. They are the ideal heating appliance that saves money while operating without reducing comfort or convenience.

Single or dual heat exchangers located inside the tank may be connected to a variety of different heating systems - Solar heating, Space heating, Geothermal heating, and Boiler heating. These systems can also be utilized in separate, or in combined configurations resulting in greater application flexibility.

Available dual, or single backup heating element (4500W or standard, 5500W) provides heat only when solar energy does not satisfy demand. Dual element models allow the entire tank to hold hot water during periods where solar heating is not available.

SOLAR EXAMPLE

300 gallon tank designed to preheat domestic water to 100 degrees with a boiler back-up to raise the water temperature from 100 degrees to 140 degrees.

- From the solar collector - 110 degrees
- Delta T - 20 degrees
- Incoming water temperature - 50 degrees
- Outlet temperature - 140 degrees
- 1 - coil as Boiler back up
- 3 - coils from the solar collectors
- 8.7 gallons continuous draw
- 700 gallons first hour rating

SOLAR COILS

74,666 btu's

67,200 btu's

74,666 btu's

Total - 216,533 btu's/hr 7.6 min flow rate Boiler back-up coil:

- From the boiler - 180 degrees
- Inlet water temperature - 100 degrees
- Outlet water temperature - 140 degrees
- 5.9 continuous draw 533 First hour rating
117,629 btu's 11.9 min flow rate

LAARS CUSTOM TANKS AND COMPONENTS

CUSTOM AND SPECIAL TANKS

Many vessels are unique to specific applications and because of this Laars Heating Systems will build custom tanks for a host of other applications. Applications include aerospace, boiler, buffer, chemical, compressor, hot water storage, laboratory, petrochemical, pharmaceutical, refrigeration and steam. We are capable of producing any size storage vessel required, from carbon or stainless steel.

Simply provide us with the overall size, working pressure, desired material and number and size of nozzles or fittings and we can work up a quotation with that information. When ordering, please specify interior and exterior coating treatment. Currently, Laars can supply glass, epoxy and rubber interior coatings.



EXAMPLES INCLUDE

Air Eliminator Tanks - Designed to improve boiler efficiencies by eliminating air trapped in boiler systems piping network. The unique sparge tube design captures circulating air and forces it to the center and by slowing the vortex of water allowing air to migrate up the sparge tube to the air vent.



Boiler Blow-Off Tanks - Use Laars Blow-Off tanks when flushing steam boilers to dispense of accumulated system particulate. Many sizes available at different working pressures. The minimum size of any boiler blow-off tank shall be equal to or greater than the water capacity of the boiler as registered by 3" on the boiler gauge, or for a blow down operation of not less than one minute.



Chemical Mixers, Reactors, Process Tanks and Storage Vessels - Laars experienced engineers can design unique custom vessels to meet your application needs.

Surge Tanks - Normally designed for 125 psig, available for working pressure to 3,000 psig.



POWERED ANODE

Protect your tank investment with the Laars powered anode system for large volume tanks. The powered anode system monitors the electrical potential of the tank surfaces and supplies identical electrical potential to the anode rod(s). Because there is no difference in electrical potential, corrosion of the tank is prevented and the anodes are not consumed. The titanium anode is non-consumable so it does not need to be replaced, ever!

HOT WATER GENERATORS

Install the Laars model XT Tube Bundle Heat Exchangers into your large volume storage tanks and use in conjunction with your boiler to generate large amounts of stored hot water. Laars tube bundles can be customized to match your hot water generation needs.

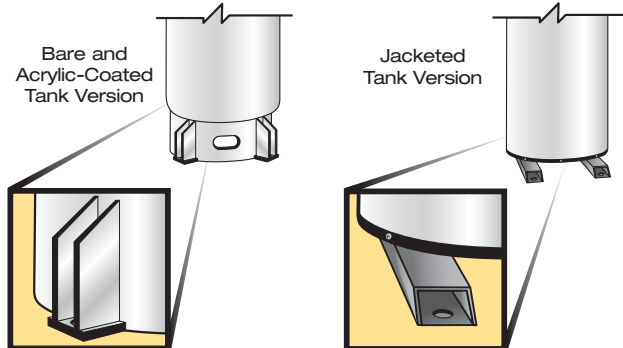

SEISMIC BRACKETS

In certain geographic areas, seismic resistance is a requirement. Laars offers two styles of seismic securing brackets for jacketed and unjacketed/acrylic-coated storage tanks. Both styles allow the tank to be bolted to the floor. These heavy-duty, welded brackets are standard equipment on all Laars custom storage tanks.

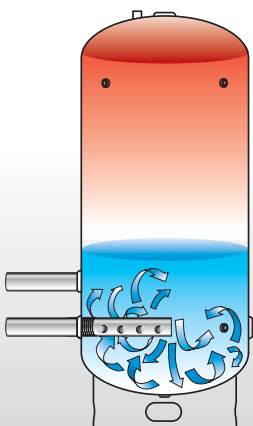

LAARS-JET® WATER INLET TUBE

This patented, stainless steel device directs the flow of incoming water to the bottom of the storage tank.

This displacement phenomenon forces existing hot water upwards toward the hot water outlet.

The LAARS-Jet® inlet tube minimizes turbulence and therefore preserves desirable thermal stratification inside the storage tank. The result is an efficient and automatic migration of usable hot water whenever there is a draw from the storage tank. The LAARS-Jet® inlet tube is available as an option, 3" NPTS only. Please specify when ordering.





View our entire product line at www.Laars.com

LAARS® 
Heating Systems Company
A subsidiary of **BRADFORD WHITE**® Corporation

800.900.9276 • Fax 800.559.1583 (Customer Service, Service Advisors)
20 Industrial Way, Rochester, NH 03867 • 603.335.6300 • Fax 603.335.3355 (Applications Engineering)
1869 Sismet Road, Mississauga, Ontario, Canada L4W 1W8 • 905.238.0100 • Fax 905.366.0130

www.Laars.com