

Identification Data

May 03, 2017

LAB GROWN DIAMOND 
Certificate Number 271110029

Gemprint

Gemprint is the unique optical fingerprint for positive identification of your lab grown diamond. Register your lab grown diamond at www.Gemprint.com and receive insurance discounts up to 10%.



Laser Inscription:

Actual image of the inscription photographed at magnification greater than 10x
Girdle laser inscribed "LAB GROWN" and "LG271110029"

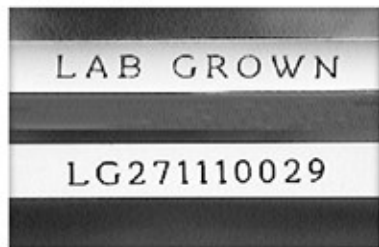

The 4Cs Grading Analysis

GCAL 271110029

LAB GROWN DIAMOND*

Carat Weight:

0.77

Cut:

Very Good

Shape:

Princess

Measurements:

4.94x4.87x3.54mm

Polish:

Very Good

External Symmetry:

Very Good

Girdle Thickness:

Medium-SI.Thick

Culet Size:

None

Color:

J

Fluorescence:

None

Clarity:

VVS2

Identifying Characteristic(s): External Growth Characteristic
Characteristic Location(s): Girdle

*Comments: This man-made diamond was grown in a laboratory by the CVD method, and has the same chemical, physical, and optical properties as a natural earth mined diamond.

This lab grown diamond is classified as Type IIa, which is the most chemically pure type of diamond, and almost or entirely devoid of impurities. Only 1-2% of natural earth mined diamonds are Type IIa, whereas, colorless and near-colorless CVD lab grown diamonds are usually Type IIa.

Photomicrographs:

Actual images of the crown (top) and pavilion (bottom) of this diamond photographed at magnifications up to 10x.



Light Performance Profile

Optical Brilliance Analysis:

Brilliance is the overall return of light to the viewer. The brilliance image is a representation of (a) white areas of light return, or brilliance, and (b) dark-blue areas of light loss.

Excellent

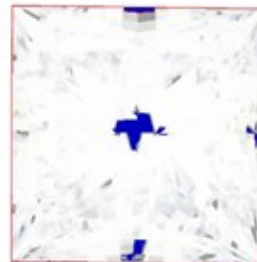

Optical Symmetry Analysis:

The colored areas of the symmetry image are indications of light handling ability, giving a visual representation of proportions and facet alignment.

Good



Proportion Diagram:

The proportion diagram illustrates the actual dimensions as recorded by optical scanning technology.

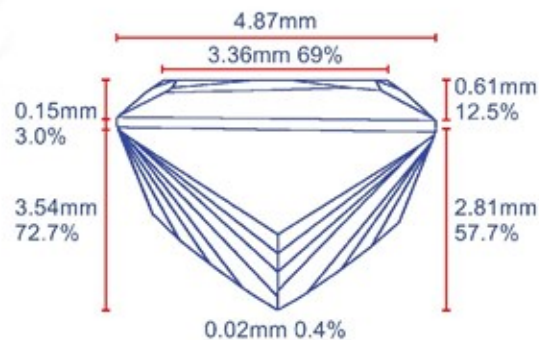

GCAL
GEM CERTIFICATION & ASSURANCE LAB
INTEGRITY GUARANTEED™



580 Fifth Avenue, New York, NY 10036, T 212.869.8985 F 212.869.2315
www.DiamondID.com, www.GemFacts.com, www.Gemprint.com

© 2017 GCAL

© 2015 Gem Certification & Assurance Lab, Inc. All Rights Reserved