

**KVH Industries, Inc.**

# TracVision® RV1



**Installation Guide**

# TracVision RV1 Installation Guide

This guide explains how to install the TracVision RV1 satellite TV antenna system on a vehicle. Operation instructions are provided in the Quick Start Guide.

---

## Installation Steps

1. Inspect Parts and Get Tools .....	3	10. Connect Power .....	16
2. Plan the Antenna Installation .....	4	11. Turn On the System.....	18
3. Plan the TV-Hub Installation.....	5	12. Access the Web Interface .....	19
4. Prepare the Antenna Site.....	6	13. Connect to an Existing Network .....	20
5. Wire the Antenna .....	7	14. Secure the Wi-Fi Connection.....	21
6. Mount the Antenna .....	8	15. Set Up the System.....	22
7. Mount the TV-Hub.....	9	16. Set the LNB Skew Angle.....	25
8. Wire the Antenna to the TV-Hub.....	10	17. Educate the Customer.....	26
9. Wire the Receivers.....	11		

## Appendices

A. Installing an IP AutoSwitch .....	27	B. Using a DIRECTV Coax Network.....	30
--------------------------------------	----	--------------------------------------	----

---

## Who Should Install the System?

To ensure a safe and effective installation, KVH recommends that a KVH-authorized technician install the TracVision antenna. KVH-authorized technicians have the tools and electronics expertise necessary to install the system. To find a technician near you, visit [www.kvh.com/wheretogetservice](http://www.kvh.com/wheretogetservice).

---

## Technical Support

If you need technical assistance, please contact KVH Technical Support:

### Europe, Middle East, Africa, Asia-Pacific

Phone: +45 45 160 180

Email: [support@emea.kvh.com](mailto:support@emea.kvh.com)

(Mon.-Thu., 8 am-4:30 pm; Fri., 8 am-2 pm, +1 GMT)

### North/South America, Australasia

Phone: +1 401 847-3327

Email: [support@kvh.com](mailto:support@kvh.com)

(Mon.-Fri., 9 am-6 pm; Sat., 9 am-2 pm ET, -5 GMT)

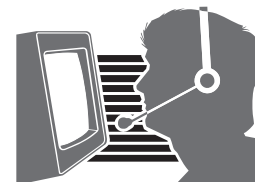

# Important Safety Information

---



This icon indicates a danger, warning, or caution notice. Be sure to read these carefully to avoid injury.



## WARNING

### Risk of Electric Shock

To avoid electric shock, do not open the TV-Hub chassis enclosure. There are no user-serviceable parts inside.



## WARNING

### Risk of Electric Shock

If any component of the TracVision system becomes damaged and/or no longer functions normally, disconnect it from vehicle power, secure it from unintended operation, and contact KVH Technical Support (see [“Technical Support” on page 1](#)). All repairs or modifications must be performed by a trained, KVH-certified technician. If you are a KVH-certified technician, you still must contact KVH Technical Support prior to conducting any repairs or modifications to the equipment.



## WARNING

### Risk of Explosion

Do not operate the TV-Hub (or any other electrical device) in an environment where flammable gases, vapors, or dusts are present. In addition, do not operate the TV-Hub in an environment with a temperature outside its 5° F to 131° F (-15° C to 55° C) temperature range.



## WARNING

### Risk of Electric Shock

Failure to ground the TracVision system properly to the vehicle’s ground will cause an unsafe floating ground condition, risking potentially lethal electric shock. See [“Connect Power” on page 16](#) for details on the proper grounding of the equipment.



## CAUTION

### Risk of Burns

Make sure the antenna is pointed away from the sun whenever the radome is removed. The high-gloss reflector can focus sunlight into a narrow beam, generating a significant amount of heat that can cause damage and injury.

# 1 Inspect Parts and Get Tools

Before you begin, follow these steps to ensure you have everything needed to complete the installation.

**IMPORTANT!**

Always lift the antenna by the baseplate and never by the radome or any portion of the internal antenna assembly (see Figure 1).

- a. Unpack the box and ensure it contains everything shown on the Kitpack Contents List. Save the packaging for future use.
- b. Carefully examine all of the supplied parts to ensure nothing was damaged in shipment.
- c. Gather the tools and materials listed below. You will need these items to complete the installation.
  - Flat-head and Phillips screwdrivers
  - Adhesive tape and scribe or pencil
  - Light hammer and center punch
  - 5/8" (16 mm) hole saw
  - Electric drill and 1/8" drill bit
  - Construction adhesive and fasteners suitable for mounting the antenna to the roof
  - 1/4" driver
  - 7/16" open-end wrench
  - 7/16" open-end torque wrenches set to 20 in.-lbs (2.25 N-m) and 15 in.-lbs (1.7 N-m)
  - Silicone sealant or equivalent
  - Torque wrench and 2 mm Allen hex key (*linear system only*)
  - Satellite TV receiver(s)/DVRs for your desired service (see Figure 2).
  - Wi-Fi-enabled laptop PC with the latest TracVision software and satellite library downloaded from the KVH Partner Portal ([www.kvh.com/partners](http://www.kvh.com/partners)), or Apple® iOS or Android™ smartphone/tablet with the latest downloads via the TracVision TV/RV mobile app

Figure 1: TracVision RV1 System Components

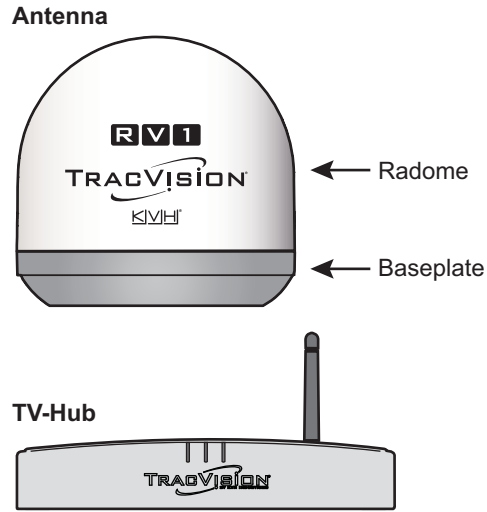

Figure 2: KVH-Validated Receivers

Linear	
For information on the recommended receivers for linear service, contact your local KVH dealer/distributor. Go to <a href="http://www.kvh.com/wheretogetservice">www.kvh.com/wheretogetservice</a> to find a dealer/distributor near you.	
DIRECTV*	DISH Network*
H20	311
H21	211
H22	211k
H23	211z
H24	
H25	Bell TV*
HR21, HR21 Pro	6100
HR22	6131
HR23	6400
HR24	
HR34	
HR44	

\* List is subject to change. For information on connecting different receiver models, contact KVH Technical Support.

# 2 Plan the Antenna Installation

Before you begin, consider the following antenna installation guidelines.

**IMPORTANT!**

Be sure to follow the guidelines below. Damage caused by an improper installation is not covered under KVH warranty.

- Minimize blockage. The antenna requires a clear view of the sky to receive satellite TV (see Figure 3). The fewer obstructions, the better the system will perform.
- Make sure the mounting surface is flat, level, wide enough to accommodate the antenna's base (see Figure 4), strong enough to support the antenna's weight, and rigid enough to prevent antenna vibration.

**IMPORTANT!**

When placed on the mounting surface, the mounting plate must lay flat against the roof (within  $\pm 1/8"$ ) to avoid warping the base and damaging the antenna.

- Select an antenna mounting location nearest to the centerline of the vehicle with the antenna's cable connector facing the rear of the vehicle.
- Be sure to mount the antenna near enough to the TV-Hub inside the vehicle to allow you to connect the 50 ft. (15 m) coax cable between them, while still maintaining sufficient slack in the cable.

**NOTE:** If you need to use a longer cable, use a RG-6 (75  $\Omega$ ) cable that does not exceed 100 ft (30 m).

- Once you've chosen a location for the antenna, identify a safe location nearby for the 5/8" cable access hole in the roof.

**IMPORTANT!**

Locate the cable access hole at least 6" away from the connector, making sure you will not drill into any existing wires or aesthetic structures inside the vehicle.

Figure 3: Blockage from Obstruction

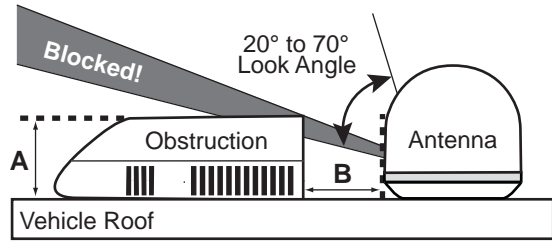

Obstruction Height (A)	Min. Distance from Antenna (B)
8"	19.5"
10"	26"
12"	32.5"
14"	39"
16"	45.5"

Figure 4: Antenna Dimensions

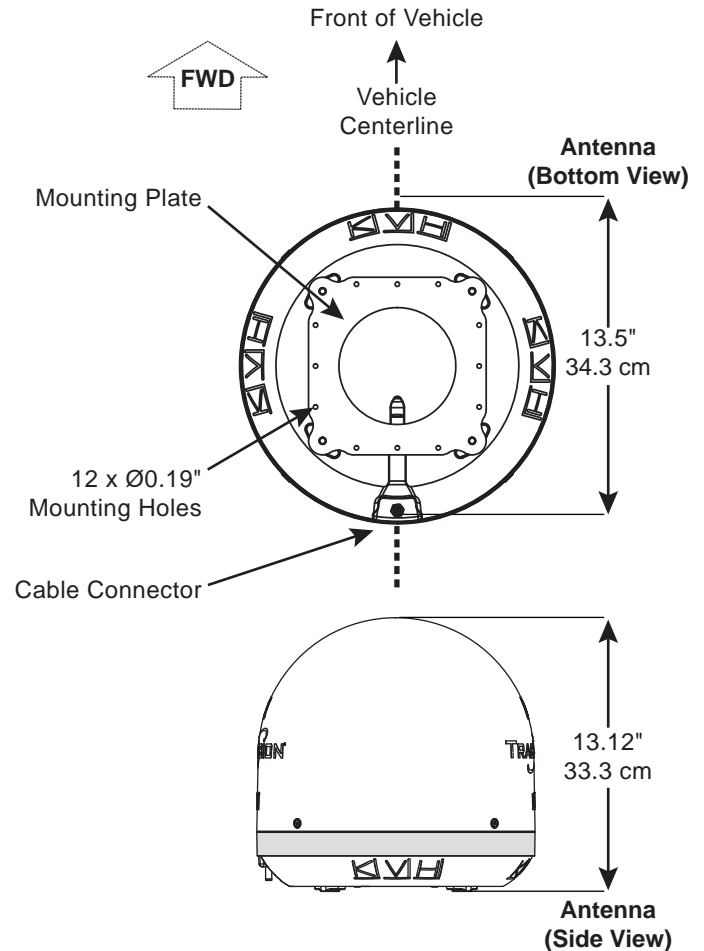

# 3 Plan the TV-Hub Installation

Consider the following TV-Hub installation guidelines.

- Select a mounting location in a dry, well-ventilated area inside the vehicle away from any heat sources.
- Do not install the TV-Hub in an area surrounded by metal or near any electrical devices that emit RF noise.
- The TV-Hub can be mounted horizontally or vertically on a flat surface (see Figure 5 and Figure 6).
- Be sure the TV-Hub LED lights will be visible to the user.
- Select a location that will provide adequate clearance for the TV-Hub dimensions (see Figure 5 and Figure 6).
- Leave enough room behind the rear panel (horizontal mount) or below the rear panel (vertical mount) to accommodate connecting the cables and making service loops within the proper bend radius.
- If you plan to use the TV-Hub's Wi-Fi connections, ensure the TV-Hub mounting location provides adequate Wi-Fi reception.
- If you plan to connect the TV-Hub to the vehicle local area network (LAN), choose a location near an available Ethernet port.

**NOTE:** A template showing the exact locations of the TV-Hub mounting holes and the dimensions between them is provided in the Welcome Kit. Installation details are provided in ["Mount the TV-Hub" on page 9.](#)

Figure 5: TV-Hub Dimensions - Horizontal Orientation

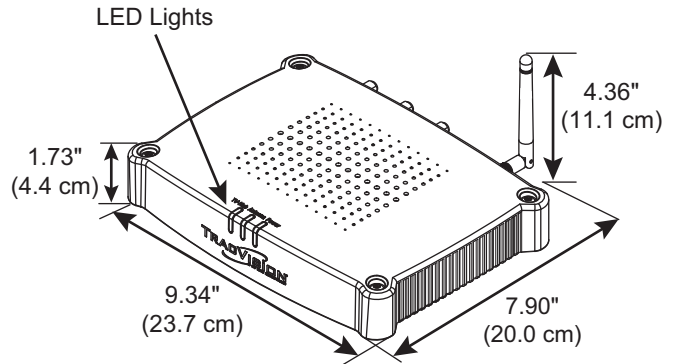
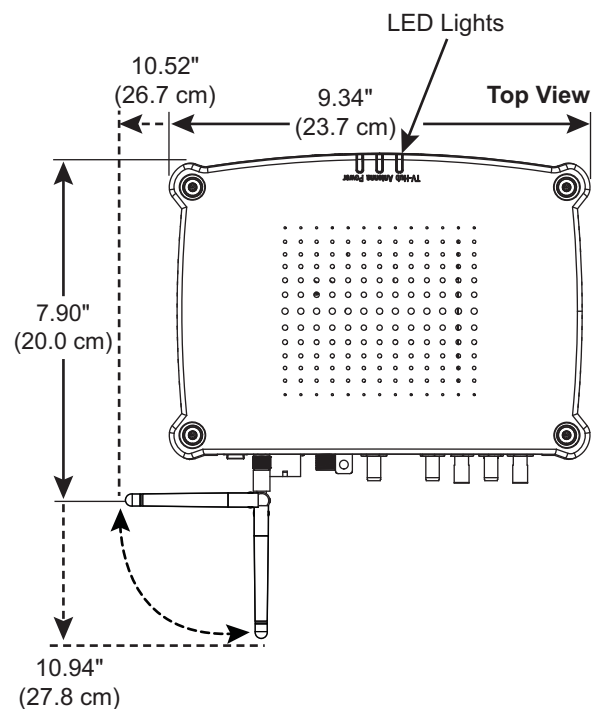

Figure 6: TV-Hub Dimensions - Vertical Orientation



# 4

## Prepare the Antenna Site

Once you have identified a suitable antenna mounting site according to the guidelines provided on [page 4](#), follow these steps to prepare the site and antenna for installation.

- a. At the location you chose in [Section 2 on page 4](#), place the mounting plate onto the mounting surface to use as a guide for any needed marking. Make sure the “forward” arrow on the mounting plate is facing the front of the vehicle and is **parallel** to the vehicle’s centerline (see [Figure 7](#)).

**NOTE:** You don’t need to mount the antenna exactly on the centerline (the closer, the better), but the antenna’s forward arrow must be **parallel** to it.

- b. Mark the location for the cable access hole (see requirements on [page 4](#)).
- c. Use a 5/8" hole saw to cut out the cable access hole in the vehicle’s roof. Smooth the edges of the hole to protect the cable.
- d. Clean and dry the antenna mounting surface.
- e. Apply appropriate construction adhesive to the bottom of the metal mounting plate across all of the holes.
- f. Attach the antenna mounting plate to the vehicle roof using 12 fasteners appropriate for the roof’s construction (see [Figure 7](#)).

**IMPORTANT!**

Due to the variation in RV roof construction, consult with the RV manufacturer to determine the safest fastening method.

- g. Seal all fasteners with silicone sealant (or equivalent).

Figure 7: Mounting Template

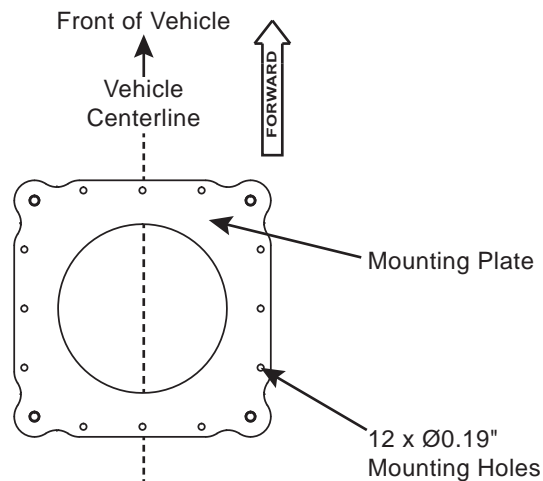

# 5 Wire the Antenna

Follow the steps below to wire the antenna.

- a. Route the RG-6 antenna cable (the end with the straight connector) down through the cable access hole and into the vehicle. You may remove the straight rubber boot for easier cable routing. Leave an adequate service loop, approximately 8" (20 cm) of slack, in the cables for serviceability. Later, you will connect this cable to the TV-Hub.

**IMPORTANT!**

Do not kink the cable. Maintain a bend radius of at least 3" (75 mm).

- b. Clean and dry the connectors on the RF cable and the underside of the antenna.



**CAUTION**

Observe the safe handling instructions in the Material Safety Data Sheet (MSDS) provided with the silicone grease.

- c. Fill half of the inner body of the RF cable's right-angle connector with the supplied silicone grease.
- d. Connect and **SLOWLY** hand-tighten the RF cable (the end with the right-angle connector) to the antenna, allowing the grease to diffuse and settle into the entire space within the connector.
- e. Make sure the RF cable is hand-tightened all the way into the connector. Then tighten it with a 7/16" torque wrench set to 20 in.-lbs, or a 7/16" wrench for 1/4 turn (see Figure 8).
- f. Wipe off any excess grease from the outside of the connector.
- g. Position the rubber boot over the connector to help protect it from weather (see Figure 8).
- h. Seal the cable access hole with a liberal amount of silicone sealant or equivalent.

Figure 8: Connecting the Antenna Cable



# 6 Mount the Antenna

Follow these steps to mount the antenna to the roof.

- a. Carefully carry the antenna to the roof of the vehicle.
- b. Attach rubber mounting feet to the bottom of the antenna in the locations shown in Figure 9.
- c. Attach the antenna to the mounting plate using the four supplied M6 nuts and Nylon washers (see Figure 10).
- d. Using a 1/4" driver with the spanner wrench supplied in the kitpack, tighten the M6 nuts until they are flush with the surrounding baseplate. Do not over-tighten.

Retain the spanner wrench for future use.

Figure 9: Attaching Rubber Mounting Feet Locations

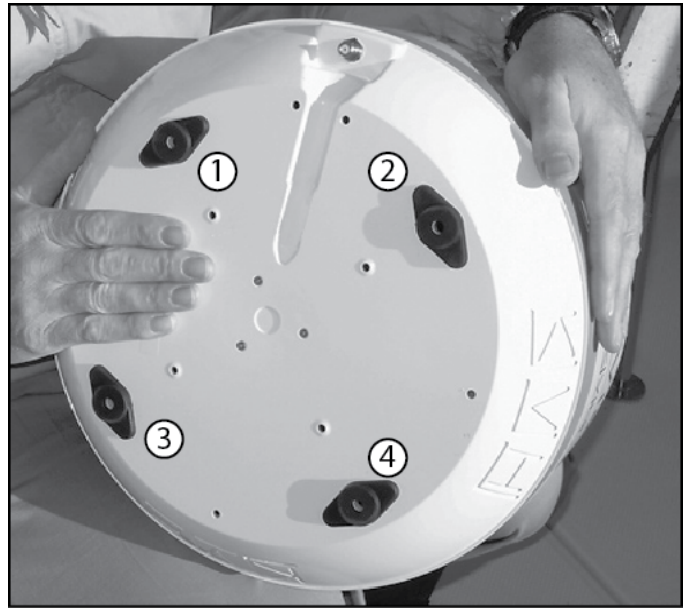
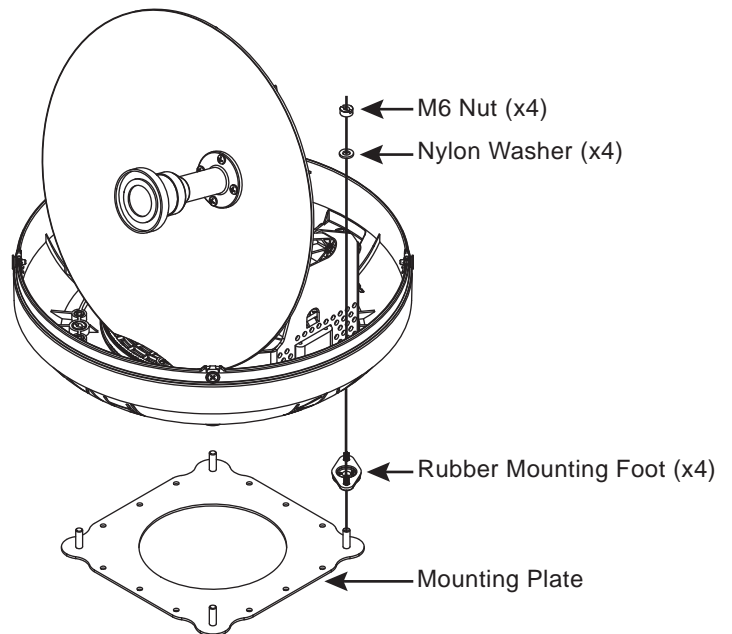

Figure 10: Attaching the Mounting Plate



# 7 Mount the TV-Hub

Follow these steps to install the TV-Hub inside the vehicle:

- a. Tape the mounting template in the location selected for the TV-Hub. Punch holes at each of the two keyhole locations and at the mounting tab location.
- b. Remove the template.
- c. Drill a 1/8" (3 mm) hole at the three hole locations you marked in Step a.
- d. Install a #8 Phillips thread-forming screw partway into one of the keyhole holes leaving a small gap for hooking the TV-Hub onto it. Use the thickness (2.5 mm) of the M10 washer (supplied in the kit) as a gauge for the size gap to leave.
- e. Repeat step d for the other keyhole.
- f. Peel off the backing on the adhesive-backed washer (supplied in the kit) and place it over the mounting tab hole (see Figure 11).
- g. Align the wide part of the TV-Hub's keyholes, as shown in Figure 12, over the screws, then slide downwards to secure the screws into the narrow part of the keyholes.
- h. Press the rear mounting tab on the TV-Hub onto the adhesive washer and install the third #8 Phillips thread-forming screw in the mounting tab hole.

Figure 11: TV-Hub Mounting Template

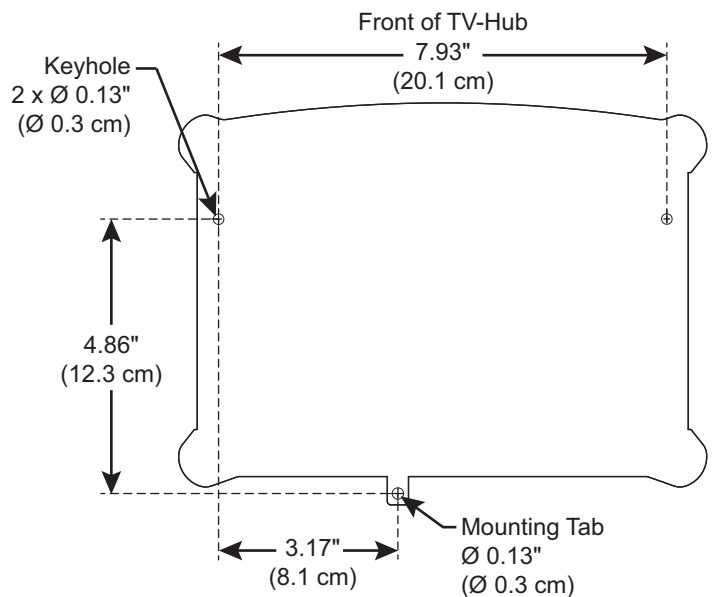
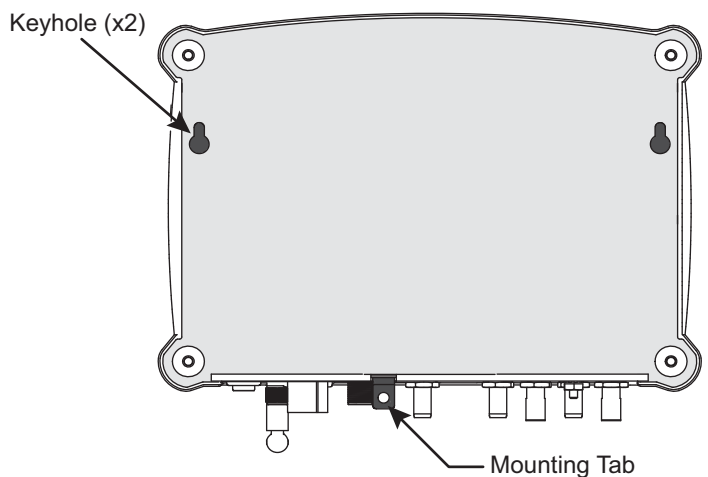

Figure 12: TV-Hub Keyholes and Mounting Tab



# 8 Wire the Antenna to the TV-Hub

Follow these steps to connect the antenna to the TV-Hub.

- a. Connect the RF1 cable from the antenna to the "Antenna" jack on the TV-Hub (see Figure 13).

**IMPORTANT!**

Do not connect anything other than the antenna's RF1 cable to the "Antenna" jack. The "Antenna" jack has 42 VDC on it which will damage other devices such as multiswitches, DVRs, etc.

- b. Hand-tighten the RF cable until it is all the way into the "Antenna" jack. Then tighten it with a 7/16" torque wrench set to 15 in.-lbs, or a 7/16" wrench 1/8 turn.

Figure 13: TV-Hub Antenna Connection

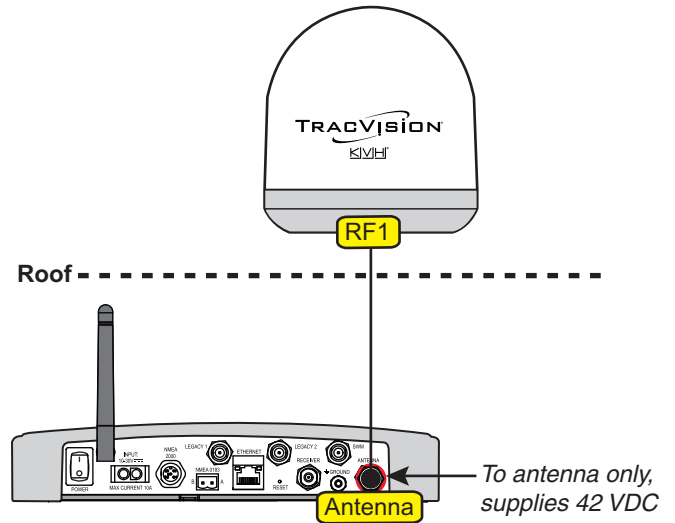

# 9 Wire the Receivers

The steps for connecting the customer's receiver(s) to the TracVision system and setting them up depends upon the customer's satellite TV service (see Figure 14 and Figure 15).

**NOTE:** KVH's *TracVision Configuration Wizard*, available at [www.kvh.com/rv1configurator](http://www.kvh.com/rv1configurator), displays a wiring diagram and parts list for all of the most common configurations.

Follow the steps in the applicable section below to wire the receivers. Then connect the receiver(s) to the customer's television(s).

- Linear..... page 12
- DIRECTV (SWM)..... page 13
- DIRECTV (Non-SWM) ..... page 14
- DISH Network/Bell TV ..... page 15

Figure 14: TV-Hub A Receiver Connections

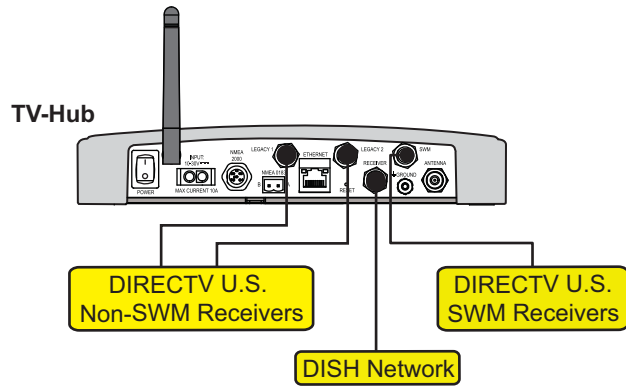
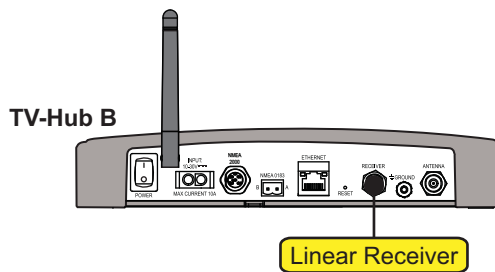

Figure 15: TV-Hub B Receiver Connections



# 9 Continued Wire the Receivers

## Linear Wiring

Follow these steps to connect a linear receiver to the TracVision system (*linear universal single LNB required*).

### Connecting a Linear Receiver

Connect an RF cable from the “Receiver” jack on the TV-Hub to the “Satellite In” jack on the receiver (see Figure 16).

Figure 16: Wiring a Linear Receiver

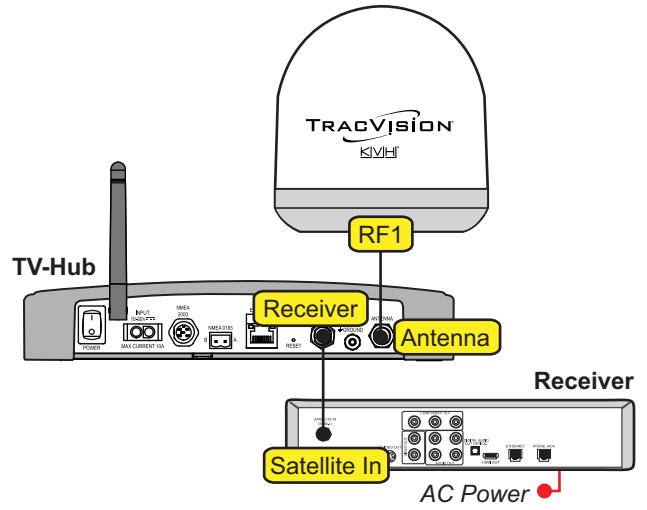

# 9 Continued Wire the Receivers

## DIRECTV – SWM Wiring

Follow these steps to connect DIRECTV SWM receivers to the TracVision system (*circular LNB and TV-Hub A required*).

**NOTE:** You can connect non-SWM receivers as well, as explained in “DIRECTV – Non-SWM Wiring” on page 14.

### Connecting 1 SWM Receiver

Connect an RF cable from the “SWM” jack on the TV-Hub to the “Satellite In” jack on the receiver/DVR (see Figure 17).

### Connecting 2-8 SWM Receivers (or Tuners)

- Connect an RF cable from the “SWM” jack on the TV-Hub to the “SWM” input on the SWM splitter (supplied in the kit) (see Figure 18).
- Connect the SWM splitter’s outputs to the “Satellite In” jack on the receivers/DVRs (or “Network” jack when connecting a Genie client). You can connect any number of SWM and Genie devices that add up to 8 tuners or fewer. Refer to Figure 18 to determine the tuners consumed by each type of device.
- Terminate any unused outputs on the SWM splitter with the supplied 75Ω terminators and verify all connections are tight.

#### IMPORTANT!

If you need to receive local channels on the 119W satellite, and you want the antenna to automatically switch between the 101W and 119W satellites, you need to use the DIRECTV coax network. See Appendix B on page 30 for details.

Figure 17: Wiring 1 DIRECTV SWM Receiver

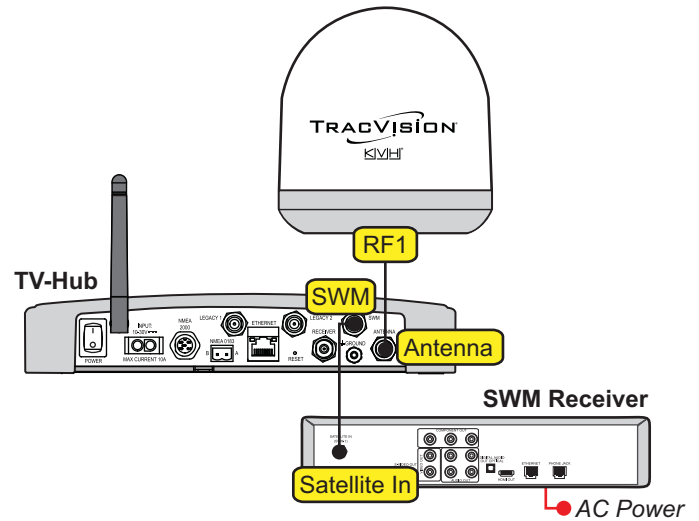
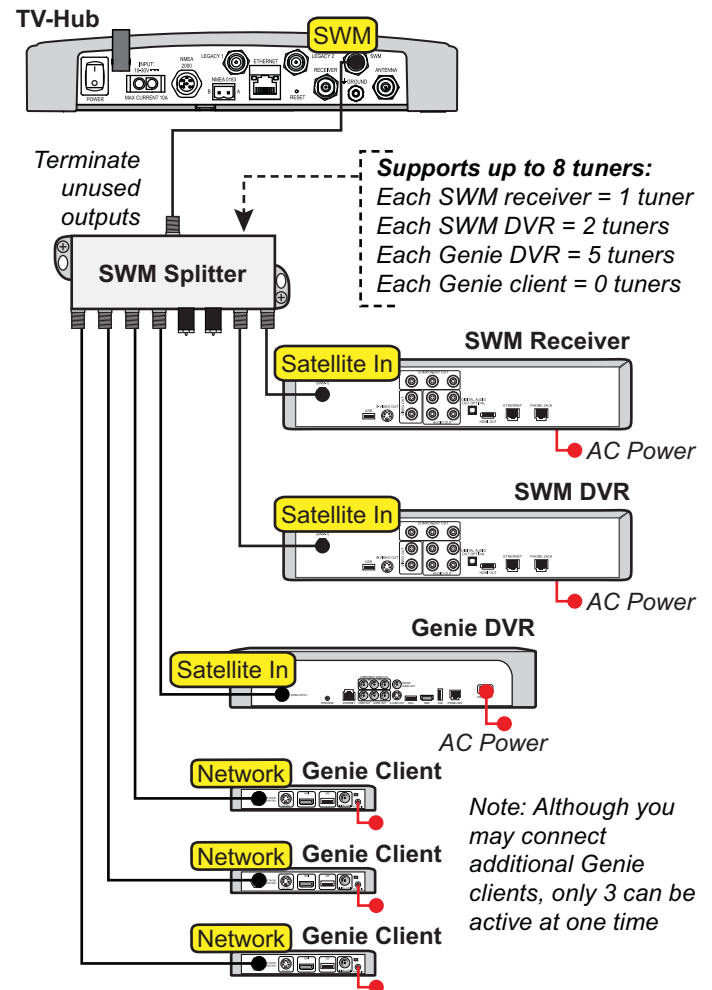

Figure 18: Wiring a DIRECTV SWM Splitter



# 9 Continued Wire the Receivers

## DIRECTV – Non-SWM Wiring

Follow these steps to connect non-SWM receivers to the TracVision system (*circular LNB and TV-Hub A required*).

### IMPORTANT!

Non-SWM receivers are limited to manual satellite switching only.

**NOTE:** You can connect SWM receivers as well, as explained in “DIRECTV – SWM Wiring” on page 13.

### Connecting 1-2 Receivers

- Connect an RF cable from the “Legacy 1” jack on the TV-Hub to the “Satellite In” jack on the receiver (see Figure 19).
- When installing two receivers, connect an RF cable from the “Legacy 2” jack on the TV-Hub to the “Satellite In” jack on the second receiver.

### Connecting 3 or More Receivers

To connect three or more non-SWM receivers, you need an 8-output multiswitch kit (KVH part no. 72-0677), which includes two DC block splitters.

- Connect an RF cable from the “Legacy 1” jack on the TV-Hub to the “Antenna” jack on one of the DC block splitters (see Figure 20).
- Connect the “Primary” jack on the DC block splitter to the “18V” jack on the multiswitch, and connect the “Secondary” jack on the DC block splitter to the “18V/22KHz” jack on the multiswitch.
- Repeat steps a and b with “Legacy 2” and the second DC block splitter using the “13V” and “13V/22KHz” jacks on the multiswitch.
- Connect the multiswitch outputs to the “Satellite In” jacks on the non-SWM receivers.
- Terminate any unused outputs on the multiswitch with 75Ω terminators and verify all connections are tight.

Figure 19: Wiring 1 to 2 DIRECTV Non-SWM Receivers

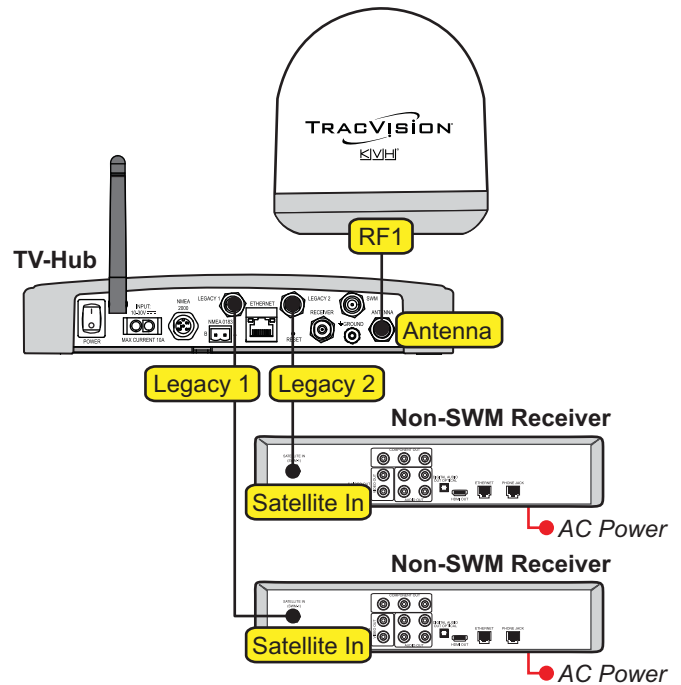
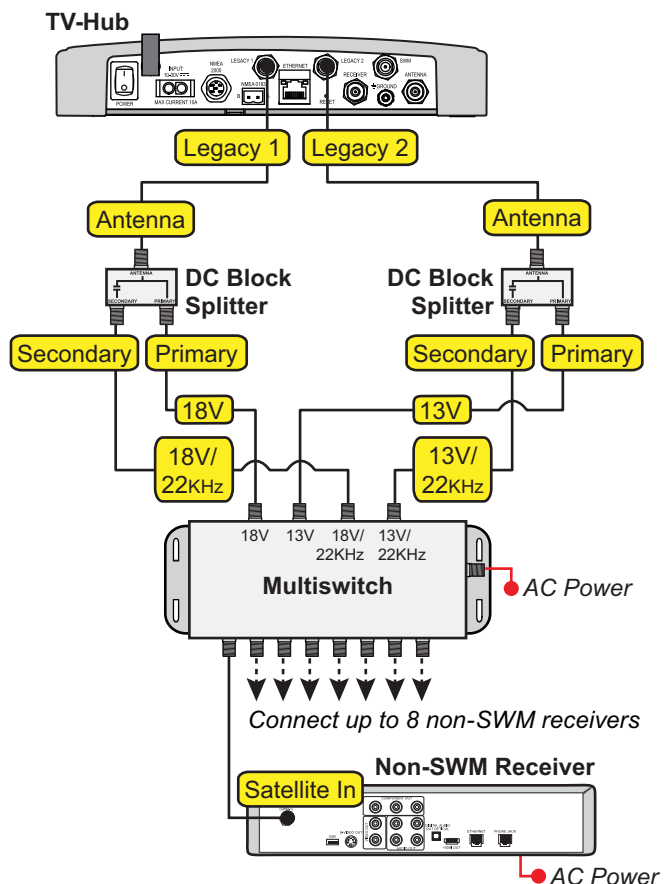

Figure 20: Wiring 3+ DIRECTV Non-SWM Receivers



# 9 Continued Wire the Receivers

## DISH Network and Bell TV Wiring

Follow these steps to connect DISH Network or Bell TV receivers to the TracVision system (circular LNB required).

### IMPORTANT!

Receivers must be DISH Pro-compatible. Look for the DISH Pro logo on the box.

### Connecting 1 Receiver

Connect an RF cable from the "Receiver" jack on the TV-Hub to the "Satellite In" jack on the receiver (see Figure 21).

### Connecting 2 or More Receivers

- Connect an RF cable from the "Receiver" jack on the TV-Hub to the "Antenna" jack on the DC block splitter (supplied in the kit).
- Connect the "Primary" jack on the DC block splitter to the "Satellite In" jack on the first receiver. *This receiver will be able to control satellite selection in Automatic satellite switching mode (DISH Network only).*
- If you need to connect just a second receiver, connect the "Secondary" jack on the splitter to the "Satellite In" jack on the second receiver (see Figure 22).

If you need to connect three or more receivers, connect the "Secondary" jack on the splitter to the "18V" port on a multiswitch (see Figure 23). KVH offers a 4-output passive multiswitch (KVH part no. 72-0676) and an 8-output active multiswitch (KVH part no. 72-0677).

- When using a multiswitch, connect the multiswitch outputs to the "Satellite In" jacks on the receivers.

### IMPORTANT!

(DISH Network only) To enable any of the additional receivers to control satellite selection in Automatic satellite switching mode, install an optional IP Autoswitch (KVH part no. 72-0634) in-line with its RF input. See Appendix A on page 27 for details.

Figure 21: Wiring 1 DISH/Bell Receiver

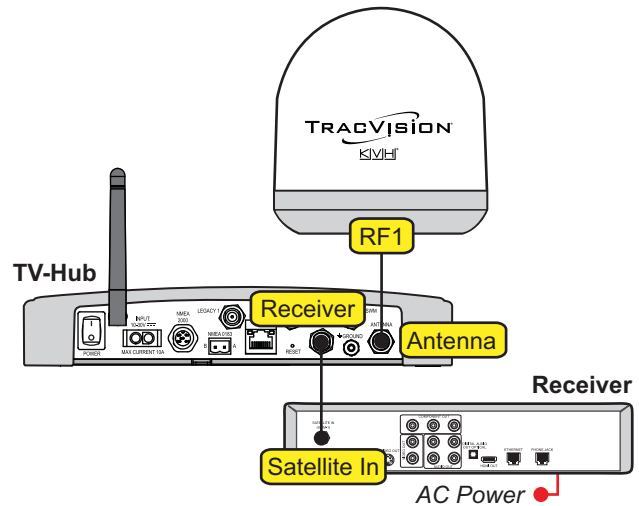

Figure 22: Wiring 2 DISH/Bell Receivers

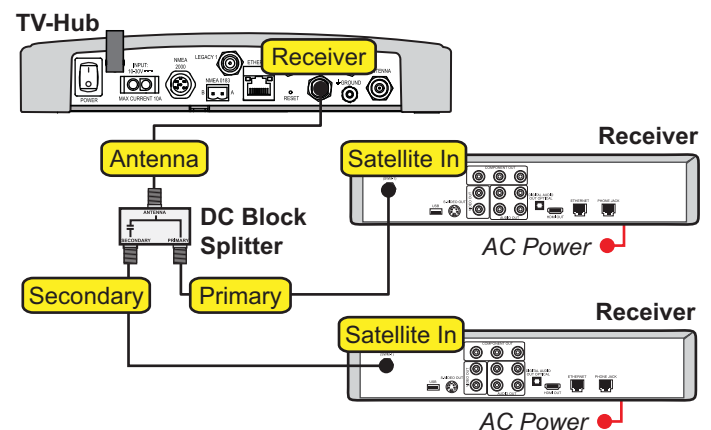
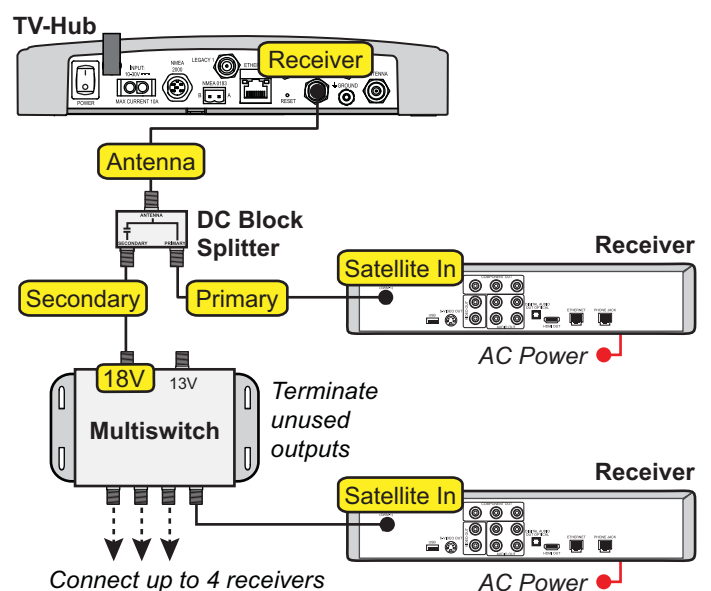

Figure 23: Wiring 3+ DISH/Bell Receivers



# 10 Connect Power

Before connecting power, be sure the vehicle is properly grounded.

## Grounding Requirements

Proper grounding of the TracVision system to the vehicle's ground is critically important, as it protects the equipment from lightning and electrostatic discharges (ESD). Follow these steps to ground the system.

- a. Connect the hoop of the grounding wire (supplied in the kit) to the "Ground" screw on the rear panel of the TV-Hub (see Figure 24).
- b. Connect the other end of the grounding wire to the vehicle's ground.

Figure 24: TV-Hub Grounding Connections

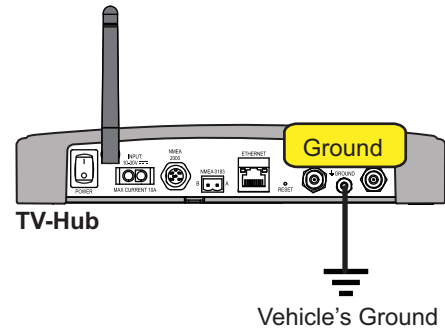

### WARNING

**Failure to ground the TracVision system properly to the vehicle's ground will cause an unsafe floating ground condition, risking damage to the antenna and electric shock, potentially resulting in DEATH.** In a floating ground condition, the difference between the equipment's chassis ground and the vehicle's ground can measure well over 100 volts, when it normally should not exceed 25 volts. Therefore, always measure the difference in potential between chassis ground and the vehicle's ground to make certain that there is no dangerous floating ground condition, even if the ground pin of the vehicle's AC power plug appears to be intact.

# 10 Continued Connect Power

## Connect Power to the System

**NOTE:** When powering up a SWM configuration, apply power to all other system components before powering up the receivers and DVRs (tuners are assigned SWM channels during startup).

Follow the steps below to connect power to the TracVision system (see Figure 25).

	<b>CAUTION</b>
For your own safety, shut down vehicle power before you connect the power wires.	

- a. Before you connect the power wires, turn off vehicle power and test the circuit to ensure no power is present.
- b. Make sure that the ground wire from the TV-Hub has been connected to ground as described on the previous page.

<b>IMPORTANT!</b> Do not use a cigarette lighter as a power supply. All power connections must be hard wired.
--

- c. Connect the individual power wires to a dedicated 12 VDC circuit. Connect the negative (black) wire to ground (DC return) and connect the positive (red) wire to clean +12 VDC vehicle power (10-30 VDC is required at the TV-Hub).

**NOTE:** If vehicle power fluctuates or is noisy, KVH recommends that you use the optional 24 VDC AC-DC power supply (5 A, 120 W) (KVH part no. 72-0669) to provide stable power to the TV-Hub.

- d. Reapply vehicle power.

Figure 25: TracVision System Power

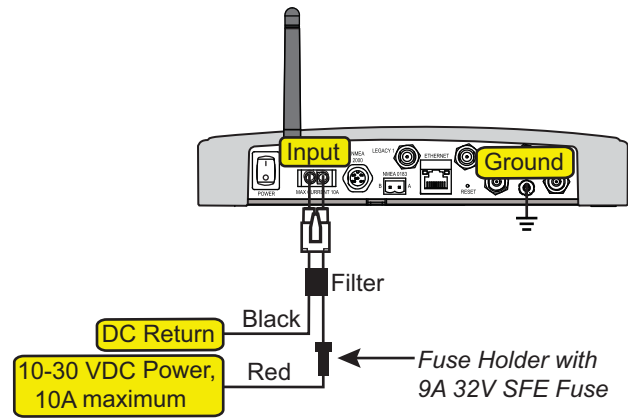

# 11 Turn On the System

Follow these steps to turn on the system for the first time.

- a. Ensure the antenna has a clear, unobstructed view of the sky.
- b. Press the power switch on the rear panel of the TV-Hub to apply power to the TracVision system (see Figure 26).

## **IMPORTANT!**

During startup, the TV-Hub checks the software versions installed in the antenna and updates them if necessary to match the versions it has stored for that model. All three status lights (see Figure 27) will alternate orange while this update is in progress. **Do not turn off the system during this time.** Updates might take up to 40 minutes.

- c. Within a few minutes, the TV-Hub and Power lights should be lit green (the Antenna light will be flashing green).
- d. Plug in and turn on any connected receivers, DVRs, Genie clients, and televisions.

Figure 26: TV-Hub Power Switch

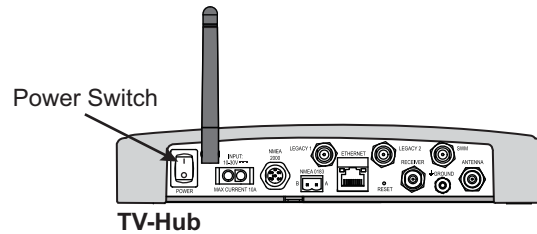
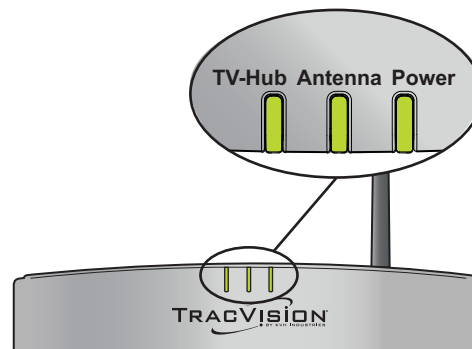

Figure 27: TV-Hub Status Lights



# 12 Access the Web Interface

Follow the steps for either option below to access the TV-Hub's web interface.

## Using the Wireless Connection

- Select the TVHub-<TV-Hub serial number> network from your device's Wi-Fi settings to connect to the TV-Hub (see Figure 28).
- Start your web browser and enter **http://tvhub.kvh**. If the web interface does not appear, try entering **http://172.16.0.1**, which is the default IP address of the TV-Hub.

## Using the Ethernet Connection

- Connect a laptop PC configured for DHCP directly to the "Ethernet" port on the TV-Hub (see Figure 29).
- Start your web browser and enter **http://169.254.253.1**.

**NOTE:** When connected to the vehicle's LAN (see "Connect to an Existing Network" on page 20), you will need to enter the IP Address (dynamic or static) assigned to the TV-Hub. If your laptop has Bonjour<sup>®</sup> installed, you can use it to find the TV-Hub on the network without knowing its IP address.

Figure 28: Wi-Fi Connection

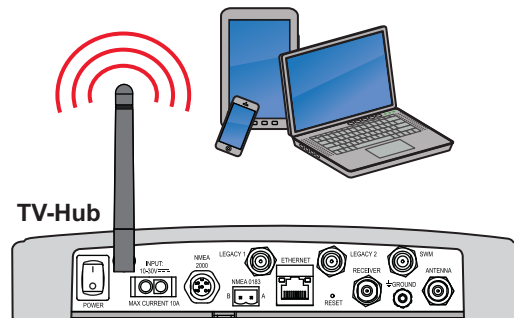
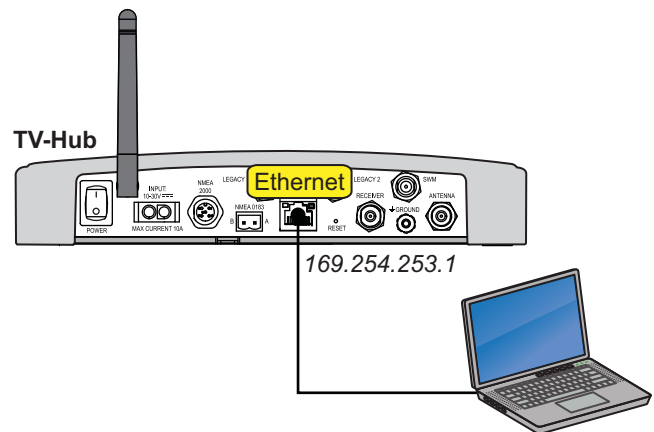

Figure 29: Wired Ethernet Connection



# 13 Connect to an Existing Network

Optional

Connecting the TV-Hub to a vehicle's local area network (LAN) is required if any of the following conditions apply:

- One or more IP AutoSwitches are installed to enable automatic satellite switching (*DISH Network only*)
- Customer wants to access the TV-Hub's web interface using any device connected to the network (see Figure 30)

**NOTE:** Connecting the TV-Hub to the vehicle's network using its Wi-Fi rather than an Ethernet cable is not recommended because you lose the ability to connect directly to the TV-Hub's built-in Wi-Fi. You will always need to connect via the network.

**NOTE:** The Reset button on the rear panel of the TV-Hub (see Figure 31) reverts all network settings back to their original factory settings.

## Wired LAN Connection

- Connect the "Ethernet" port on the TV-Hub to the onboard network (LAN) using the supplied Ethernet cable.
- By default, the TV-Hub's Ethernet port is configured as a DHCP client, and the network's router automatically assigns it an IP address. However, in this **Dynamic** mode, the TV-Hub could get assigned a different IP address whenever it is turned on.

KVH recommends that you set the TV-Hub to **Static** mode and enter a static IP address at the web interface (see Figure 32) (go to Settings > Network Settings). Be sure to choose a static IP address that is outside the router's DHCP range (refer to the router's user manual for details on finding its range.)

### IMPORTANT!

For systems with IP AutoSwitch(es), make sure they are on the same local LAN segment as the TV-Hub (see Appendix A on [page 27](#)).

For DIRECTV systems set up for automatic satellite switching, make sure the receiver(s) have IP addresses in the same subnet as the TV-Hub (see Appendix B on [page 30](#)).

Figure 30: TV-Hub Network Connections

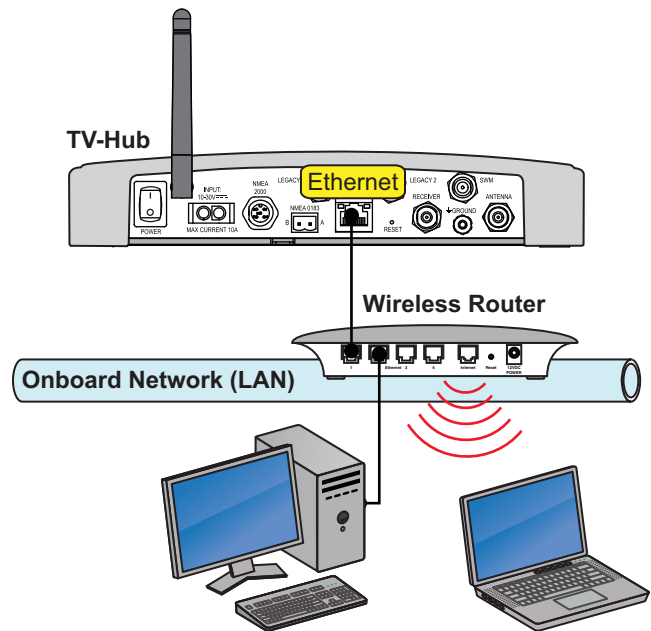

Figure 31: TV-Hub Reset Button

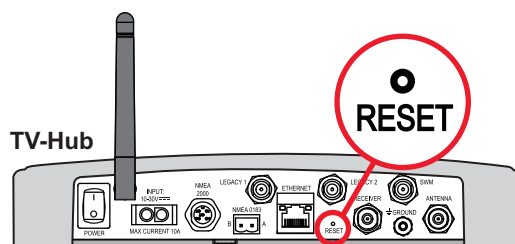

Figure 32: Web Interface Ethernet Settings

Ethernet Settings	
Mode	STATIC
IP Address	192.168.1.200
Subnet	255.255.255.0
Gateway	192.168.1.1
Broadcast	192.168.1.255

# 14 Secure the Wi-Fi Connection

By default, the TV-Hub's wireless settings are configured for the following:

- Wireless Mode: AP (Access Point)
- SSID: TV-Hub-<TV-Hub serial number>
- IP Address: 172.16.0.1
- Security Mode: Off

KVH strongly advises that you select the **WPA\_PSK** security mode as shown in Figure 33 and assign a unique password to prevent unauthorized access to the TV-Hub (at the web interface, go to Settings > Network Settings). If you keep the default settings, you're allowing anyone to access the TV-Hub with their mobile device.

**IMPORTANT!**

KVH strongly recommends that you keep the TV-Hub set to AP (Access Point) wireless mode. If you select IF (Infrastructure) mode to connect the TV-Hub to your vehicle's network, you will no longer be able to access the TV-Hub's web interface directly.

Figure 33: TV-Hub Security and Password Setting

Wireless Settings	
Wireless Mode	AP (Access Point) ▼
SSID	TVHub-140311659
IP Address	172.16.0.1
Subnet	255.255.255.0
Gateway	172.16.0.1
Broadcast	172.16.0.1
Security Mode	WPA_PSK ▼
Password	240300659

# 15 Set Up the System

The Setup Wizard appears upon initial startup to step you through system configuration (see Figure 34). Before you begin to set up the system:

- Know the service provider and associated satellite(s)
- Check the latest software version (see below)
- Verify all system components are connected

## Update Software and Satellite Library

Before you start the Setup Wizard, update the system software and satellite library to the latest versions. Use the Apple® iOS or Android™ smartphone/tablet mobile app, or follow these steps to use a laptop PC that has the latest update files downloaded to it from the KVH Partner Portal ([www.kvh.com/partners](http://www.kvh.com/partners)).

- Select **Exit** in the Setup Wizard page. The web interface appears.
- At the Updates page of the web interface, select the antenna model. Then select **Install Update** (see Figure 35). Find the **.kvh** file in your downloads folder, then double-click to install.
- Wait for the update to complete. It may take up to 45 minutes. The TV-Hub's lights will alternate orange while the update is in progress. Once complete, the web interface will report that the latest version is installed.
- When the software update is complete, select the Satellite Library. Then select **Install Update**. Find the **.xml** file in your downloads folder, then double-click to install.
- Close the web interface. Then reopen it (see [“Access the Web Interface” on page 19](#)). The Setup Wizard will reappear since setup has yet to be completed.
- Select **Proceed with Setup Wizard**.

Figure 34: Setup Wizard Welcome Page

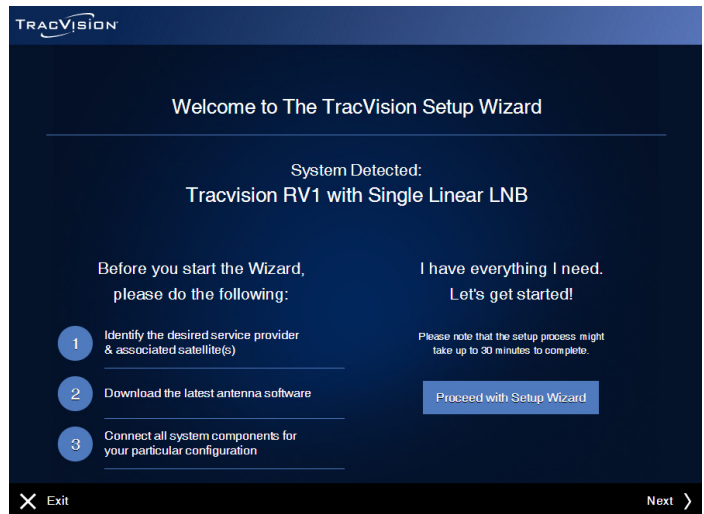
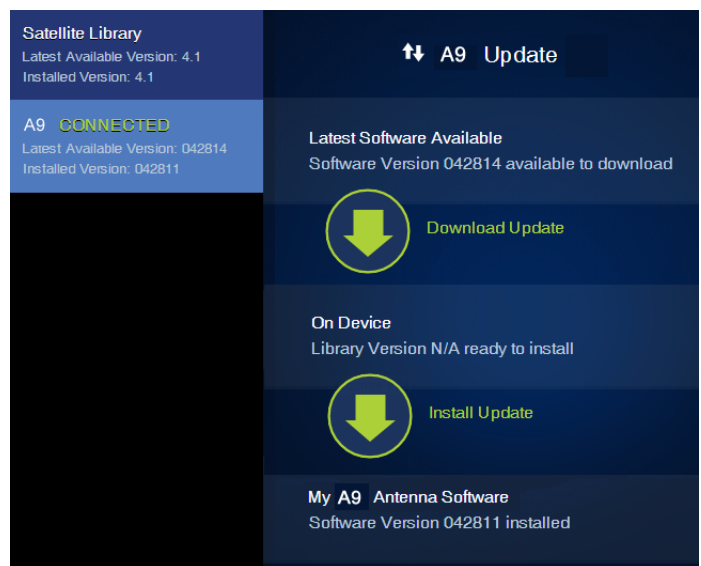

Figure 35: Software Updates Page



# 15 Continued Set Up the System

## Setup Wizard

System configuration continues by prompting you to enter information or perform specific tasks, as necessary. For example:

- Enter installer and vessel information
- Select a source for GNSS position data
- Select the satellite TV service
- Select satellite(s) to track (make your own selections or select one of the preset groups listed in Figure 36), or create user-defined satellites
- Set up automatic switching, if applicable

## Additional Setup Information

Once the Setup Wizard has been completed, perform follow-up tasks such as:

- Set up receivers to operate with the system (as instructed by the Wizard)
- Activate the receivers (as instructed by the Wizard)
- Set the antenna's LNB to the skew angle provided by the Wizard (see ["Set the LNB Skew Angle"](#) on page 25; applies to linear systems only)

Figure 36: Preset Satellite Groups

Service	Satellites (A-B-C-D)
Linear	Create a custom group if multiple satellites are needed
DIRECTV U.S.	<b>DIRECTV Dual:</b> 101W and 119W
DISH Network	<b>Western Arc:</b> 110W, 119W, 129W <b>Legacy East Arc:</b> 61W, 110W, 119W <b>DISH 500:</b> 110W, 119W
Bell TV	No preset groups supported, but compatible with 91W

Note: This list is subject to change.

# 15 Continued Setup the System

## Linear Receiver Setup for Automatic Switching

For automatic switching to work properly using the DiSEqC communications protocol, set up the linear receiver for the same satellites installed in the TracVision system. Set up the satellites in the receiver in the exact same order as they were set up in the antenna. The specific setup process varies among receiver models – refer to the receiver’s manual for details. Use the table below and Figure 37 as a guide.

Satellites in Antenna	Matching Satellites in Receiver
Slot A	Port/Switch/LNB/DiSEqC 1 or A
Slot B	Port/Switch/LNB/DiSEqC 2 or B
Slot C	Port/Switch/LNB/DiSEqC 3 or C
Slot D	Port/Switch/LNB/DiSEqC 4 or D

Figure 37: Linear Receiver DiSEqC Settings (Example)

The screenshot displays the TV-Hub Web Interface for Receiver Setup. It is divided into two main sections: 'TV-Hub Web Interface' and 'Receiver Setup'.

**TV-Hub Web Interface:**

- Satellite Group Name:** MyEuropeGroup
- Slot A:** Hotbird 6,7,8 Europe - 13E
- Slot B:** Astra 1 - 19E
- Slot C:** Astra 4A - 5E
- Slot D:** Eutelsat W3A - 7E

**Receiver Setup (Slot A):** Ku\_HOTBIRD 6,7A,8

- LNB Type: 09750/10600
- LNB Power: 13/18V
- 22KHz: Auto
- Toneburst: None
- DiSEqC1.0: LNB1
- DiSEqC1.1: None
- Motor: None

**Receiver Setup (Slot B):** Ku\_ASTRAS 1H,1KR,1L,1M

- LNB Type: 09750/10600
- LNB Power: 13/18V
- 22KHz: Auto
- Toneburst: None
- DiSEqC1.0: LNB2
- DiSEqC1.1: None
- Motor: None

**Receiver Setup (Slot C):** Ku\_ASTRAS 4A

- LNB Type: 09750/10600
- LNB Power: 13/18V
- 22KHz: Auto
- Toneburst: None
- DiSEqC1.0: LNB3
- DiSEqC1.1: None
- Motor: None

**Receiver Setup (Slot D):** Ku\_Eutelsat 7E

- LNB Type: 09750/10600
- LNB Power: 13/18V
- 22KHz: Auto
- Toneburst: None
- DiSEqC1.0: LNB4
- DiSEqC1.1: None
- Motor: None

# 16 Set the LNB Skew Angle

## Linear Systems Only

Follow these steps to set the antenna's LNB to the skew angle supplied by the Setup Wizard.

- a. At the rear panel of the TV-Hub, set the power switch to the Off position. Verify its Power light goes out.

	<b>CAUTION</b>
Disconnect power from the antenna before you remove the radome. The antenna has moving parts that can cause injury.	

- b. Remove the four #8-32 screws securing the radome to the antenna (see Figure 38).
- c. Carefully lift the radome straight up until clear of the antenna assembly and set it aside in a safe place. Do not place the radome on a hot steel surface – the heat may warp the radome.

### IMPORTANT!

Make sure the antenna is pointed away from the sun whenever the radome is removed. The high-gloss reflector can focus sunlight into a narrow beam, generating a significant amount of heat that can cause damage and injury.

- d. Locate the LNB on the back of the antenna's reflector (see Figure 39).
- e. Using a 2 mm Allen hex key, loosen the two M4 set screws securing the LNB to the choke feed (see Figure 40).
- f. Adjust the LNB, clockwise or counter-clockwise, until the skew arrow on the LNB points to the correct skew angle you noted when running the Setup Wizard.

### IMPORTANT!

Make sure the LNB is fully inserted into the choke feed to ensure optimum performance.

- g. Tighten the two M4 set screws to secure the LNB in place. Apply 11 in.-lbs (1.2 N-m) of torque, if possible.
- h. Reinstall the radome.

Figure 38: Removing the Radome

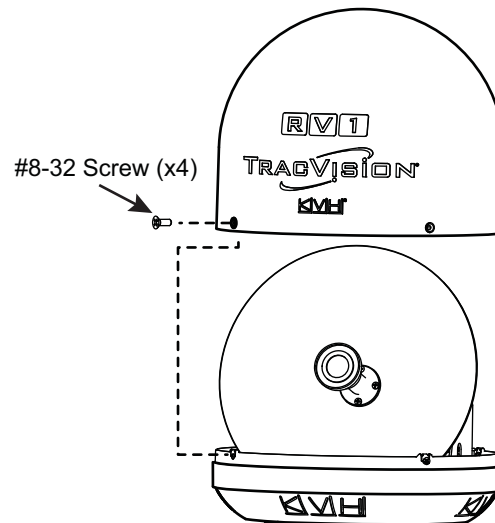

Figure 39: Location of LNB on Back of Antenna Reflector

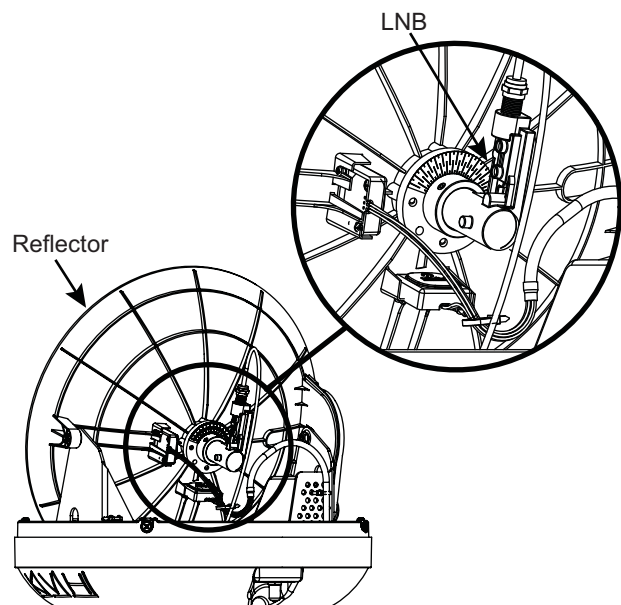
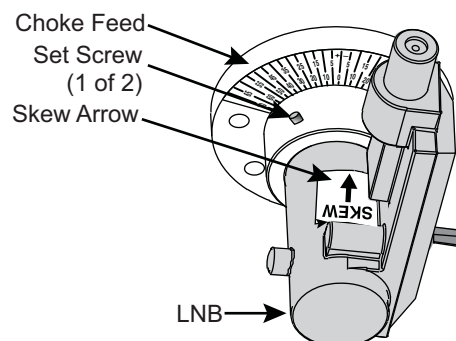

Figure 40: LNB Skew Angle Adjustment



# 17 Educate the Customer

Before you leave the vehicle, test the system to ensure the antenna works properly. Fill out the Installation Checklist (provided in the Welcome Kit) and return it to KVH. Refer to the instructions on the form.

Give the Welcome Kit to the customer, provide any passwords and static IP addresses you set up, and explain how to use the system. Ensure the customer understands the following.

- How to:
  - Turn on the system
  - Access the web interface
  - Switch satellites (see Figure 41)
  - Select a master receiver (see Figure 42)
  - Interpret TV-Hub status
  - Download software and satellite library updates (using web interface and/or mobile app)
  - Perform general troubleshooting
- Keep the radome installed on the antenna at all times. The radome protects the antenna's moving parts from wind, rain, and debris.

	<b>CAUTION</b>
In the unlikely event that you need to remove the radome, remove power from the antenna first because the antenna's moving parts can cause injury.	

- The antenna must have a clear view of the sky to receive satellite TV. Common causes of blockage include trees, buildings, bridges, overpasses, and mountains (see Figure 43). The TracVision system will not work inside a garage. Heavy rain or snow might also temporarily interrupt reception.
- Clean the antenna regularly. Dirt buildup on the radome can affect satellite TV reception.
- You must be located within the satellites' coverage area to receive TV signals. Visit [www.kvh.com/footprint](http://www.kvh.com/footprint) for coverage maps.
- Please register the system to ensure the best possible service from KVH. Visit [www.kvh.com/register](http://www.kvh.com/register) for details.

Figure 41: Satellite Switching Selection on Home Page

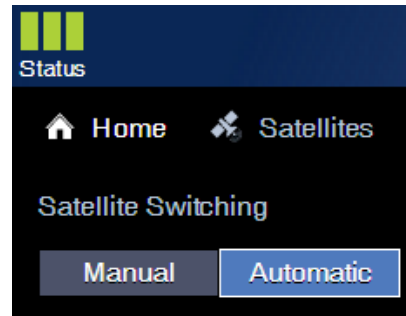

Figure 42: Master Receiver Selection

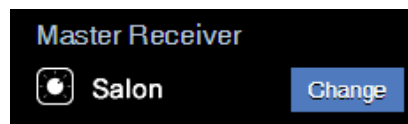
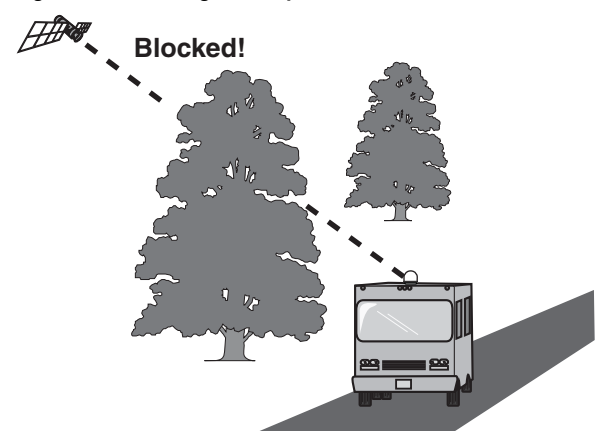



Figure 43: Blockage Example



	<b>WARNING</b>
It is dangerous to watch TV while driving a vehicle. While the vehicle is in motion, the system is intended for passenger use only.	

# A Installing an IP AutoSwitch

Follow these steps to add an IP AutoSwitch (KVH part no. 72-0634) to each DISH Network receiver you want to be able to control satellite selection in Automatic satellite switching mode.

**NOTE:** A receiver connected directly to the TV-Hub's "Receiver" jack can control satellite selection without an IP AutoSwitch.

### Inspect Parts

Follow these steps to inspect the kit contents.

- a. Unpack the box and ensure it contains each of the following items:
  - 3 ft (1 m) Ethernet cable
  - 2 ft (60 cm) RF cable
  - Adhesive-backed Velcro strip
- b. Carefully examine all of the supplied parts to ensure nothing was damaged in shipment.
- c. Locate the serial number on the bottom of the IP AutoSwitch (see Figure 45) and record it on the Installation Checklist (supplied in the Welcome Kit) for future reference.

### Choose a Mounting Location

Choose a mounting location that meets the following requirements:

- Dry, well-ventilated, and away from heat sources
- Provides a clear view of and easy access to the Master Select button (see Figure 45)
- Provides adequate clearance for running the cables and allows for service loops and strain relief
- Within 2 ft (60 cm) of the associated receiver in order to use the supplied cable
- Either a horizontal or vertical surface

Figure 44: IP AutoSwitch



Figure 45: Serial Number and Master Select Button

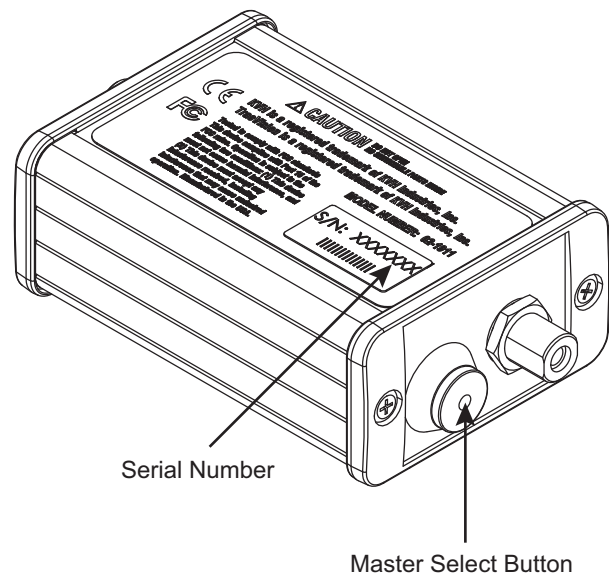

# A

# Continued Installing an IP AutoSwitch

## Wire the IP AutoSwitch

The wiring of the IP AutoSwitch depends on the specific configuration. Refer to the wiring diagrams provided in “DISH Network and Bell TV Wiring” on page 15, while following the general wiring steps below:

- Disconnect the RF input cable from the receiver and connect it to the “RF In” jack on the IP AutoSwitch. Then tighten to 15 in.-lbs of torque.
- Connect the supplied 2 ft (60 cm) RF cable from the “To Receiver” port on the IP AutoSwitch to the receiver’s satellite input and tighten to 15 in.-lbs of torque.
- Using the supplied Ethernet cable, connect the “Network” port of the IP AutoSwitch to the onboard network. If a network is not available, install a router as shown in Figure 46.
- If not already connected, connect the TV-Hub to the onboard network (see Figure 46).
- Using the supplied Velcro strip, secure the IP AutoSwitch to the mounting surface.

Figure 46: IP AutoSwitch Connections

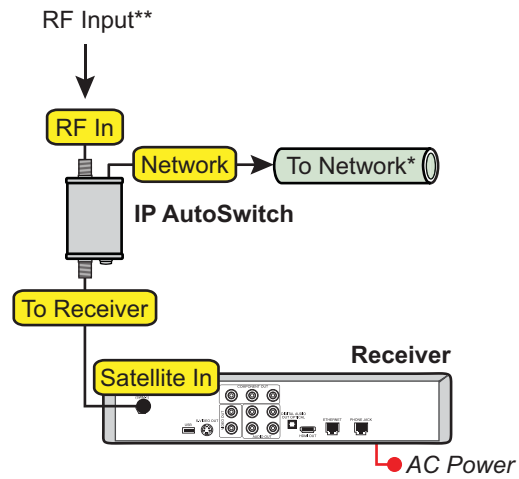

\*\* Varies depending on your system configuration

### \* Network Connections

Connect the TV-Hub and IP AutoSwitch(es) to your onboard network. If you do not have a network, install a router or router and switch as shown below.

#### TV-Hub

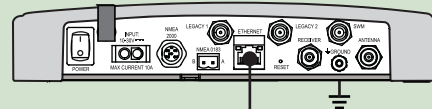

#### Router

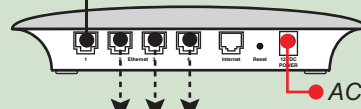

Connect up to 3 IP AutoSwitches

OR

To TV-Hub

#### Router

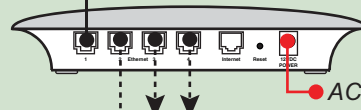

Connect up to 2 IP AutoSwitches

#### Switch

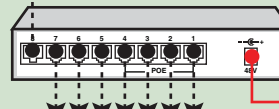

Connect up to 7 IP AutoSwitches

# A

# Continued Installing an IP AutoSwitch

## Configure the IP AutoSwitch

When performing system setup (see “Set Up the System” on page 22), follow these additional steps to configure the IP AutoSwitch.

*NOTE: KVH recommends that you run the Setup Wizard in the web interface whenever you change your system’s configuration by adding or removing devices.*

- At the AutoSwitch page of the web interface, select **Add IP AutoSwitch** (Figure 47).
- Enter the serial number and choose a friendly name for the IP AutoSwitch (for example, “Master Bedroom”).
- Select **Save** to save your changes.

## Select the Master Receiver

Any receiver connected to an IP AutoSwitch can become the master receiver for the system. The master receiver controls satellite selection.

### IMPORTANT!

The TV-Hub has a built-in IP AutoSwitch. Any receiver connected directly to the TV-Hub can therefore be selected as a master receiver through the web interface.

- To choose the master receiver, select it on the Home page of the web interface, or press the Master Select button on the associated IP AutoSwitch.
- Verify that the LED in the Master Select button on the IP AutoSwitch is lit green (see Figure 48). The LEDs for any other IP AutoSwitches should be lit orange.

Figure 47: Add IP AutoSwitch Screen

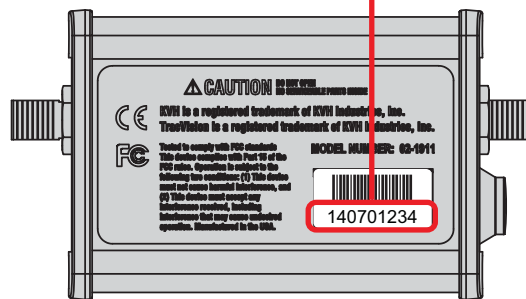
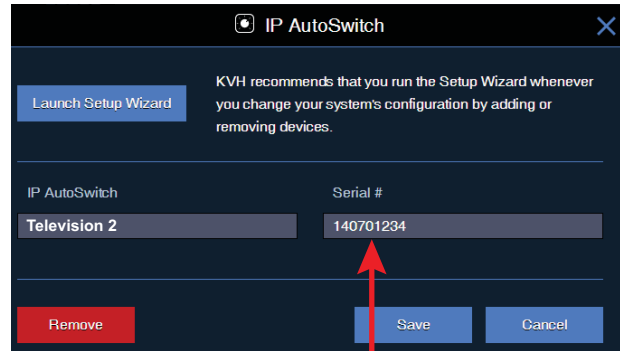

Figure 48: IP AutoSwitch LED Status Indications

LED Color	Indication
Orange	Registered with the system but not currently the master
Orange, flashing	Initializing
Red	Error: <ul style="list-style-type: none"> <li>unable to communicate with the system,</li> <li>network is not detected, or</li> <li>unable to register</li> </ul>
Green	Registered with the system and currently the master

# B Using a DIRECTV Coax Network

In Automatic satellite switching mode, the TV-Hub can accept commands from the master SWM-compatible DIRECTV receiver to automatically switch between the 101W and 119W satellites. The TV-Hub communicates with the master receiver via the TV-Hub's Ethernet port link to the DIRECTV coax network. Follow the steps in this section to set up this communication link with SWM-compatible receivers

**NOTE:** The 119W satellite only carries local channels for certain regions of the country. (You can find a list of these regions in the Setup Wizard.) If the customer's locals are carried on DIRECTV's main 101W satellite, there is no need to switch satellites.

### DIRECTV Coax Network Connections

DIRECTV recently adopted coax networking technology, by which both satellite TV signals and network communications data are carried by the coax cables. This simplifies installation, since Ethernet cables don't need to be run to all of the receivers.

### Non-Genie Configurations

If a Genie DVR (HR44 or HR34) is not present on the DIRECTV SWM network, you need to install a DECA with power supply and DC to RF adapter, collectively referred to as a DECA Broadband Kit (KVH part no. 19-0860) and formerly called a Cinema Connection Kit. When connected to the SWM splitter and the TV-Hub's Ethernet port, either directly or via an onboard router, the DECA relays messages between the DIRECTV coax network and the Ethernet network (see Figure 49).

Figure 49: Non-Genie Configuration

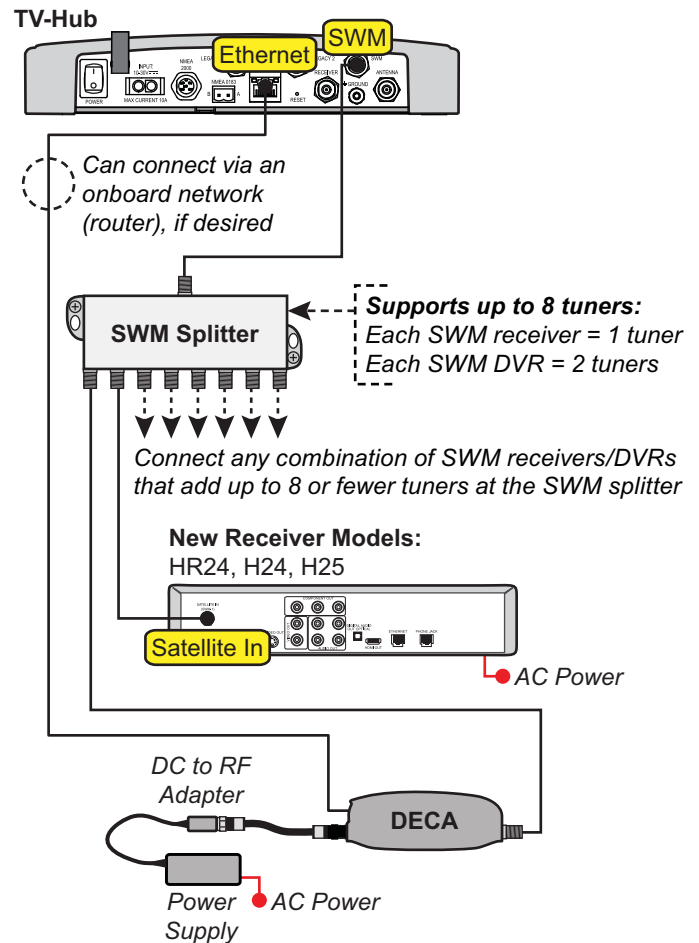

# B Continued Using a DIRECTV Coax Network

## Genie Configurations

Full DECA Broadband functionality is built into Genie DVRs (HR44 or HR34). So if a Genie DVR is present on the DIRECTV SWM network, no external DECA Broadband kit is required. Just connect the Genie's Ethernet port to the TV-Hub's Ethernet port, either directly or via an onboard router (see Figure 50). The Genie DVR provides the link between the DIRECTV coax network and the Ethernet network.

*NOTE: If you cannot easily connect the Genie DVR's Ethernet port to the TV-Hub or an onboard network, you can use a DECA Broadband Kit, as explained in "Non-Genie Configurations" on page 30.*

*NOTE: Genie clients cannot switch satellites; they can only view programming carried by the satellite that is currently selected.*

Figure 50: Genie Configuration

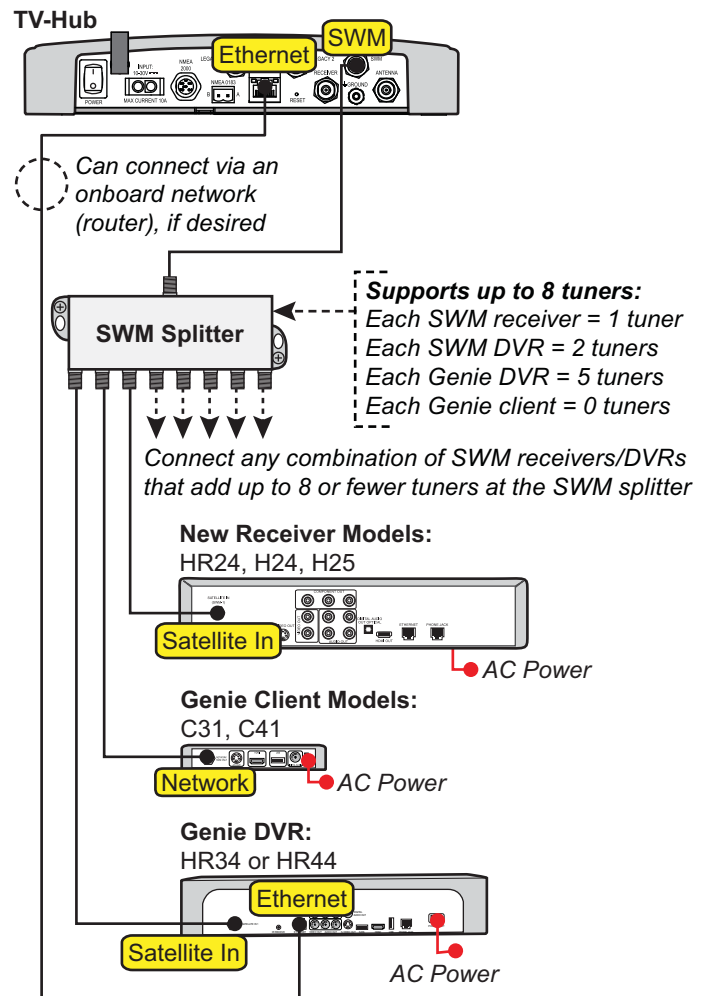

# B Continued Using a DIRECTV Coax Network

## Additional Equipment for Older Receivers

In addition to the DECA Broadband Kit or a Genie DVR, you might need to connect an additional device in-line between the receiver and the SWM splitter, depending on the model (see Figure 51).

*NOTE: Model HR20-100 requires additional devices not specified here. Contact KVH Technical Support.*

### H21, H22, H23, HR21, HR22, and HR23

These receivers do not have built-in DECA functionality, but they have an Ethernet port for network connectivity. An additional DECA (KVH part no. 19-0860) is required to support coax networking, supplying the satellite TV signal to the receiver's "Satellite In" port and network communications data to its Ethernet port. (If there are two of each port, use the "Satellite In 1" and "Ethernet 1" ports.)

*NOTE: Each DECA you connect directly to a receiver is powered by the receiver. They do not require the separate power supply included in the kit.*

### H20

This receiver is not network-ready. It is only designed to receive a satellite TV signal via its "Satellite In" port. Since both the satellite TV signal and network communications data are present on the coax cables, a band stop filter (KVH part no. 19-0868) is required to block the network data to prevent potential damage to the receiver. Since the H20 cannot communicate over the network, it cannot control satellite selection.

#### **IMPORTANT!**

Be sure to connect all band stop filters before connecting the coax cables.

Figure 51: Additional Equipment for Older Receivers

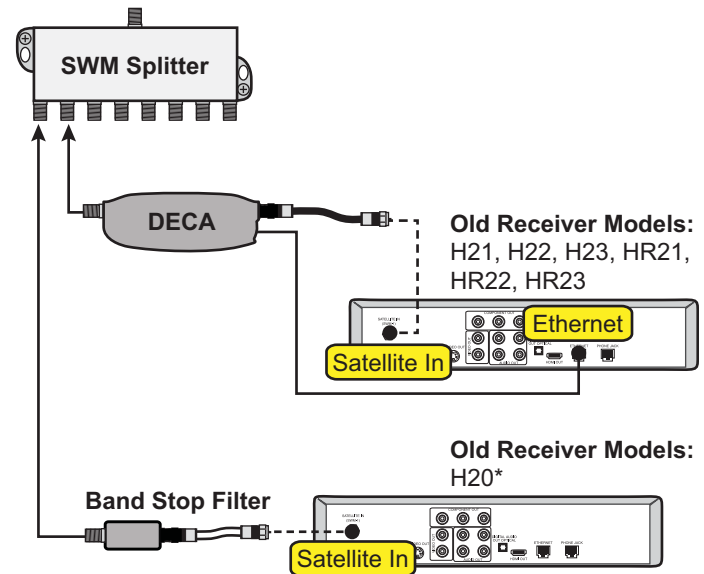

*\* Model HR20-100 may require additional hardware. Contact KVH Technical Support for details.*

# B Continued Using a DIRECTV Coax Network

## Configuring the DIRECTV Receivers for Automatic Switching

To establish communications between the TracVision system and each SWM-compatible DIRECTV receiver for automatic satellite switching, you need to set each receiver to a static IP address and enter that address, along with the receiver's location, in the TV-Hub's web interface.

### Static IP Address Range WITHOUT an Onboard Network

If the DECA Broadband Kit or Genie DVR is connected directly to the TV-Hub's "Ethernet" port (no router is installed), set each receiver's IP address to any address ranging from 192.168.x.2 to 192.168.x.149, where  $x=1 < \text{the last 2 digits in the TV-Hub's serial number}$ .

For example, if the serial number of the TV-Hub is 140901484, you might assign an IP address of 192.168.184.2 (see Figure 52). Refer to the instructions in ["Assigning Static IP Addresses to DIRECTV Receivers" on page 34](#). The TV-Hub has a hidden IP address of 192.168.x.1 reserved for automatic switching communications. This IP address is not shown on the Network Settings page of the web interface.

### Static IP Address Range WITH an Onboard Network

If the TV-Hub and the DECA Broadband Kit or Genie DVR are connected to an onboard network (i.e., router), set each receiver to a static IP address that is outside the router's DHCP range (see Figure 53). (Refer to the router's user manual for details on finding its IP address range.) For example, if the router has an IP address of 192.168.1.1 and assigns IP addresses ranging from 192.168.1.100 to 192.168.1.149 via DHCP, you could set each receiver's IP address to any address ranging from 192.168.1.150 to 192.168.1.254. Refer to the instructions in ["Assigning Static IP Addresses to DIRECTV Receivers" on page 34](#).

Figure 52: IP Addressing for Automatic Switching (Example)

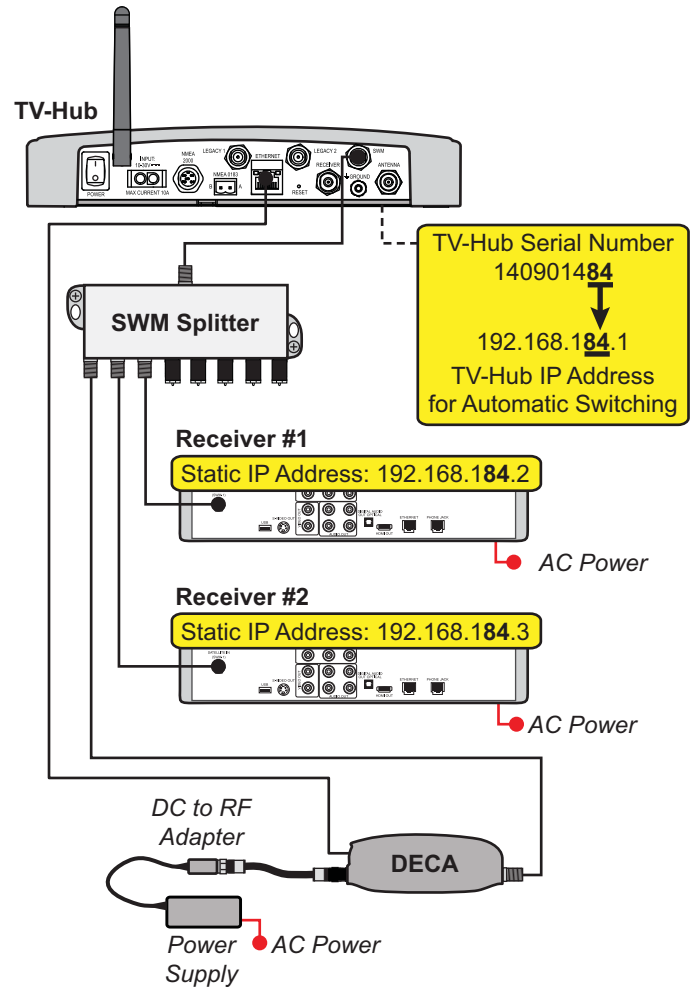

Figure 53: Router DHCP Settings (Example)

IP Address:	192 . 168 . 1 . 1
Subnet Mask:	255.255.255.0
Router Name :	Cisco76205
DHCP Server:	<input checked="" type="radio"/> Enabled <input type="radio"/> Disabled <input type="button" value="DHCP Reser"/>
Start IP Address:	192 . 168 . 1 . 100
Maximum Number of Users:	50
IP Address Range:	192 . 168 . 1 . 100 to 149
Client Lease Time:	0 minutes (0 means one day)

# B Continued Using a DIRECTV Coax Network

## Assigning Static IP Addresses to DIRECTV Receivers

Once you have identified a valid static IP address range for the receivers, follow these steps to assign a unique static IP address within that range to each receiver.

*NOTE: These steps may vary, depending on the receiver's model and software version. Refer to the receiver's owner's manual for details.*

- a. Press **MENU** on the receiver's remote control to access the onscreen menu.
- b. At the main menu, highlight **Settings & Help**. Then select **Settings**.
- c. Highlight and select **Network Setup**.
- d. Select **Advanced Setup**.
- e. Change the IP address to the new static IP address. (On a Genie DVR, the IP address is called the "Server IP") (see Figure 54).
- f. **WITHOUT an Onboard Network**  
Enter "255.255.255.0" for the subnet mask, and enter the TV-Hub's IP address for default gateway and DNS.

### WITH an Onboard Network

Enter the router's subnet mask, and enter the router's IP address for default gateway and DNS.

- g. Highlight and select **Connect Now** to save your changes. Disregard any error messages about missing Internet connectivity. Note this receiver's IP address and location onboard for future reference.
- h. Repeat this procedure for each additional receiver. Be careful not to use the same IP address twice.

Figure 54: IP Address on a DIRECTV Receiver (Example)

### WITHOUT an Onboard Network (No Router)



### WITH an Onboard Network (Using a Router)



# B Continued Using a DIRECTV Coax Network

- i. Add the new receivers to the Autoswitch page of the web interface. Enter each receiver's static IP address and assign it a friendly name (e.g., "Master Bedroom") (see Figure 55).

**IMPORTANT!**

Also be sure to set each receiver's Dish Type to **3-LNB** and Switch Type to **SWM**, and enable external device access, as directed by the TV-Hub's Setup Wizard. If the TV-Hub is then unable to communicate with the receiver, try resetting the receiver (press its red reset button or unplug it, wait 15 seconds, then plug it back in and turn it on).

Figure 55: Adding a DIRECTV Receiver to the Autoswitch Page

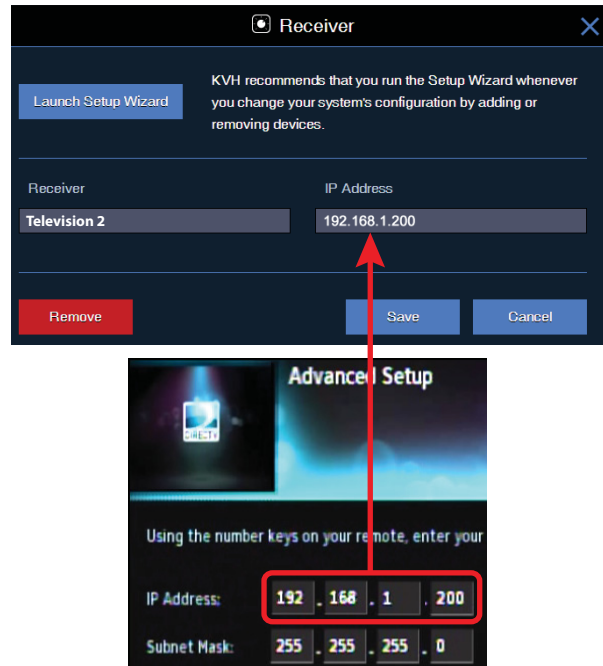



[www.kvh.com](http://www.kvh.com)



---

**KVH Industries A/S**  
*EMEA Headquarters*  
Kokkedal, Denmark  
Tel: +45 45 160 180 Fax: +45 45 160 181  
E-mail: [info@emea.kvh.com](mailto:info@emea.kvh.com)

**KVH Industries, Inc.**  
*World Headquarters*  
Middletown, RI U.S.A.  
Tel: +1 401 847 3327 Fax: +1 401 849 0045  
E-mail: [info@kvh.com](mailto:info@kvh.com)

**KVH Industries Pte Ltd.**  
*Asia-Pacific Headquarters*  
Singapore  
Tel: +65 6513 0290 Fax: +65 6472 3469  
E-mail: [info@apac.kvh.com](mailto:info@apac.kvh.com)