



TracVision® R1dx with Multi-service Interface Box/Controller



TracVision R1dx Installation Guide

TracVision R1DX Installation Guide

Multi-service Interface Box/Controller Configuration

These instructions explain how to install the TracVision R1DX satellite TV antenna system on a vehicle. Complete instructions on how to use the system are provided in the *User's Guide*.

Installation Steps

- | | |
|---------------------------------------|--|
| 1. Inspect Parts and Get Tools3 | 8. Mount the Interface Box10 |
| 2. Plan the Installation.....4 | 9. Turn On the System.....11 |
| 3. Prepare the Antenna5 | 10. Set Up the System.....12 |
| 4. Wire the Antenna6 | 11. Enter Latitude & Longitude14 |
| 5. Mount the Antenna7 | 12. Run Check Switch Tests.....15 |
| 6. Wire the Interface Box.....8 | 13. Educate the Customer.....17 |
| 7. Connect Power.....9 | |

Who Should Install the System?

To ensure a safe and effective installation, KVH recommends that a KVH-authorized technician install the TracVision R1DX antenna. To find a technician near you, please visit www.kvh.com/wheretogetservice.

Related Documentation

The following additional documents are provided with the TracVision R1DX system:

<u>Document</u>	<u>Description</u>
User's Guide	Operation, setup, and troubleshooting information
Product Registration Form	Details on registering the product with KVH
Warranty Statement	Warranty terms and conditions
Contents List	List of every part supplied in the kit

Technical Support

If you need technical assistance, please contact KVH Technical Support:

Phone: +1 401 847-3327

E-mail: techs@kvh.com

(Mon.-Fri., 9 am-6 pm ET; Sat. 9 am-2 pm ET)

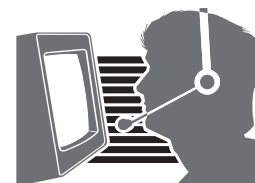

1 Inspect Parts and Get Tools

Before you begin, follow these steps to make sure you have everything you need to complete the installation.

IMPORTANT!

Always lift the antenna by the baseplate and never by the radome or any portion of the internal antenna assembly (see Figure 1).

NOTE: Henceforward, this manual uses the term “interface box” to refer to the multi-service interface box/controller.

- a. Unpack the box and ensure it contains everything shown on the *Kitpack Contents List*. Save the packaging for future use.
- b. Carefully examine all of the supplied parts to ensure nothing was damaged in shipment.
- c. Gather all of the tools and materials listed below. You will need these items to complete the installation.
 - #2 Phillips screwdriver
 - 7/16" open-end wrench
 - Cutting pliers
 - Silicone sealant, RTV, or equivalent
 - Construction adhesive suitable for the roof
 - Fasteners suitable for mounting the antenna to the roof
 - 5/8"- diameter hole saw
 - Augat IT1000 connector installation tool (KVH part #19-0242)
 - Eight 1/4" fasteners (see “Mount the Interface Box” on page 10)
 - RG-6 or RG-11 RF coax cable(s) to connect the receiver(s) (see “Wire the Interface Box” on page 8)
 - Satellite TV receiver(s) for your desired service (see Figure 2 for a list of validated receivers; for information on connecting different receiver models, contact KVH Technical Support at 401-847-3327)

Figure 1: TracVision R1DX System Components

Antenna

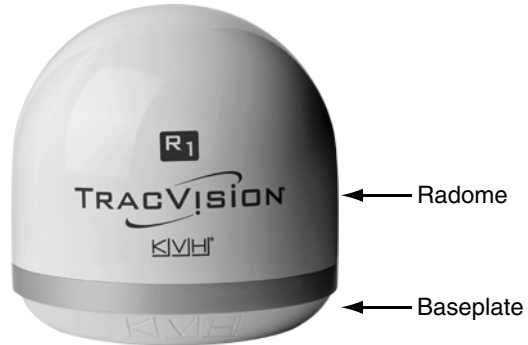

Multi-service Interface Box/Controller



Figure 2: KVH-Validated Receivers

Standard-Definition Models	
DIRECTV	DISH Network
D12	311 (discontinued)
D11 (discontinued)	211k
D10 (discontinued)	211
High-Definition (HD) Models	
DIRECTV	DISH Network
HD not supported	211k
	211

2 Plan the Installation

Before you begin, consider the following installation guidelines:

- Minimize blockage. The antenna requires a clear view of the southern sky to receive satellite TV. Using the guidelines in Figure 3 as a guide, mount the antenna a suitable distance away from obstructions on the roof, such as air conditioners.
- Ensure the mounting surface is flat and strong enough to support the antenna's weight (7.5 lbs).

IMPORTANT!

When placed on the mounting surface, all four mounting plates must lay flat against the roof (within 7/16") to avoid warping the base and damaging the antenna.

- Select an antenna mounting location on the centerline of the vehicle with the antenna's cable connector facing the rear of the vehicle (see Figure 4).

NOTE: A template showing the exact locations of the antenna mounting holes and the dimensions between them is provided in the Welcome Kit.

- Be sure to mount the antenna near enough to the interface box to allow you to connect the 50-ft. coax cable between them, while still maintaining sufficient slack in the cable.

NOTE: If you need to use a longer cable, use an RG6 (75 ohms) cable that does not exceed 80 feet in length.

- Once you've chosen a location for the antenna, identify a safe location nearby for the 5/8" cable access hole in the roof. It should be located at least 6" away from the connector. Make sure you will not drill into any existing wires or aesthetic structures inside the vehicle.
- When choosing a location for the interface box and receiver(s), find a dry, well-ventilated area inside the vehicle away from any heat sources. Also be sure the front panel of the interface box will be easily accessible to the user.

Figure 3: Blockage from Obstruction

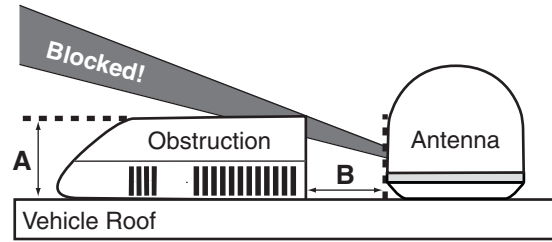

Obstruction Height (A)	Min. Distance from Antenna (B)
8"	19.5"
10"	26"
12"	32.5"
14"	39"
16"	45.5"

Figure 4: Antenna Dimensions

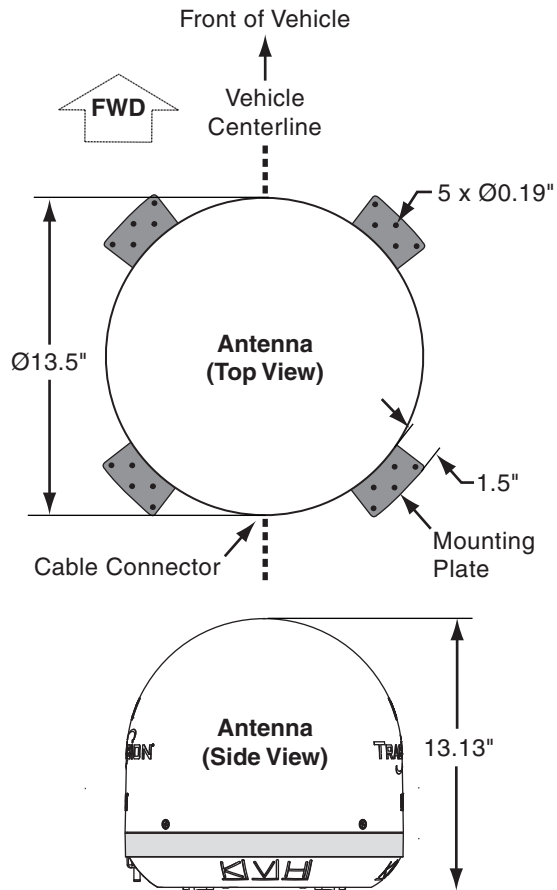

3 Prepare the Antenna

Follow these steps to attach the four mounting plates to the antenna's baseplate.

- a. Attach the four supplied metal mounting plates to the bottom of the antenna using the eight M5 screws supplied in the kitpack (see Figure 5).
- b. Over each mounting plate, fit a supplied rubber bumper into the hole in the antenna's baseplate (see Figure 5).
- c. Carefully carry the antenna to the roof of the vehicle.

Figure 5: Attaching the Mounting Plates

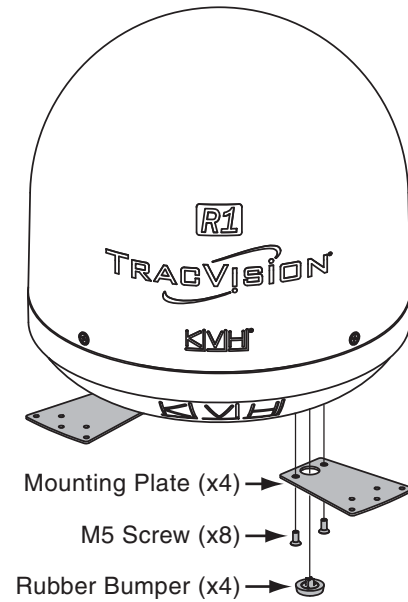

4 Wire the Antenna

Follow these steps to connect the antenna cable to the antenna.

- a. At the location you chose in Step 2 on page 4, use a 5/8" hole saw to cut out a cable access hole in the vehicle's roof. Smooth the edges of the hole to protect the cable.
- b. Route the RG6 antenna cable (the end with the straight connector) down through the cable access hole and into the vehicle. You may remove the straight rubber boot for easier cable routing. Later, you will connect this end of the cable to the interface box.

IMPORTANT!

Do not kink the cable. Maintain a bend radius of at least 3 inches.

- c. Connect the RG6 antenna cable (the end with the right-angle connector and rubber sealing boot) to the antenna. Hand-tighten, then tighten with a 7/16" wrench for 1/4 turn to ensure an electrical and weather-proof connection (see Figure 6).
- d. Position the rubber boot over the connector to help protect the connector from the elements.
- e. Leave an adequate service loop, approximately 8" of slack, in the antenna cable for easy serviceability.
- f. Seal the cable access hole with a liberal amount of silicone sealant (or equivalent) to protect against leakage.
- g. Install the supplied clamshell ventilator over the cable access hole. The clamshell's opening should face the rear of the vehicle. Secure in place with the three #6 screws supplied in the kitpack (see Figure 7). Then seal the screws with silicone sealant (or equivalent).

Figure 6: Connecting the Antenna Cable

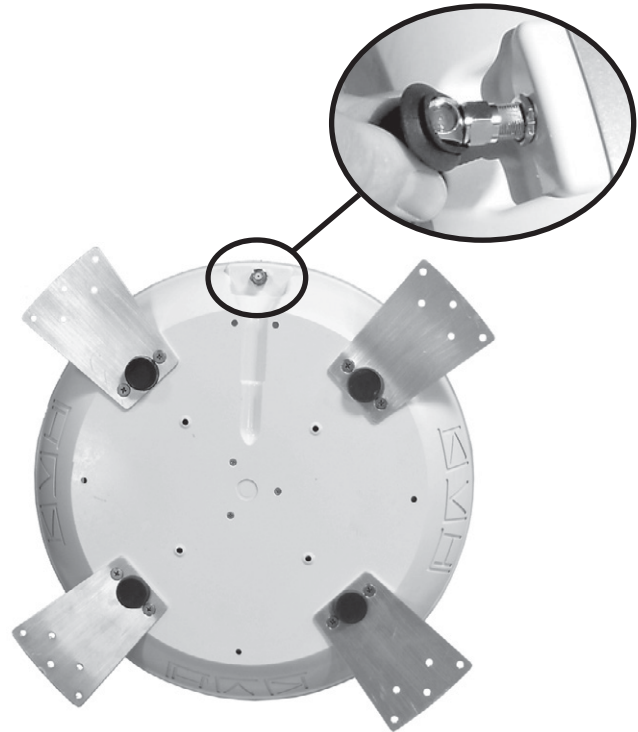
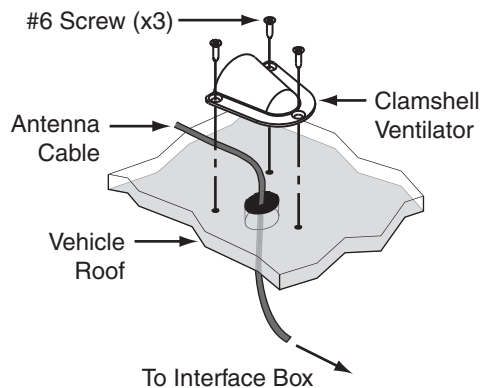

Figure 7: Mounting the Clamshell Ventilator



5 Mount the Antenna

Follow these steps to mount the antenna to the roof.

- a. Apply appropriate construction adhesive to the bottom of the antenna's four mounting plates across all of the holes.
- b. At the mounting location you chose in Step 2 on page 4, place the antenna on the centerline of the roof so that the cable connector faces the rear of the vehicle (see Figure 8).
- c. Attach the four antenna mounting plates to the roof using 20 fasteners appropriate for the roof's construction (see Figure 8).

IMPORTANT!

Due to the variation in RV roof construction, consult with the RV manufacturer to determine the safest fastening method.

- d. Seal all fasteners with silicone sealant (or equivalent).

Figure 8: Mounting the Antenna

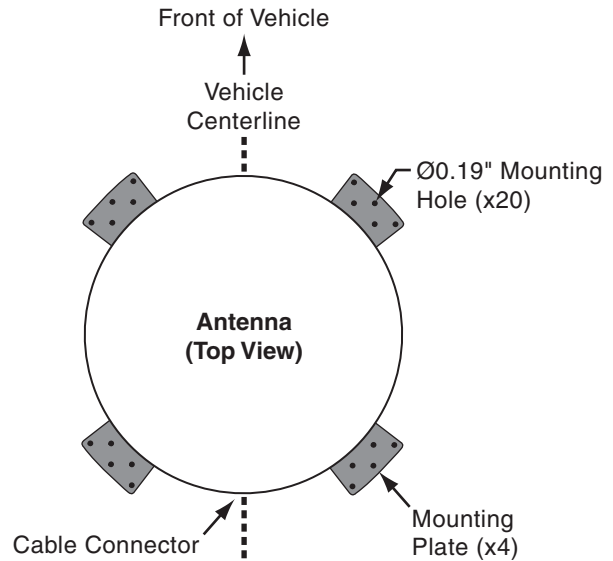

6 Wire the Interface Box

Follow these steps to connect the antenna cable and receiver(s) to the interface box.

IMPORTANT!

Terminate all RF coaxial cables, including the antenna cable, with Snap-N-Seal[®] F-connectors using an Augat IT1000 tool. Low-quality connectors will degrade system performance and KVH's warranty does not cover repairs resulting from the use of such connectors.

- Connect the antenna cable (A) to the "To KVH Antenna" jack on the interface box (see Figure 9).
- Connect an RF coaxial cable (B) from the "Unstacked Output" jack on the interface box to the "Satellite In" jack on the receiver. This receiver will control satellite selection.
- Connect the receiver to the customer's television. Follow the instructions in the receiver's manual.
- If you need to connect an additional receiver, connect the receiver to the "Stacked Output" jack on the interface box through an in-line destacker (see Figure 10 and Figure 11).

The destacker converts the stacked signal from the interface box into an unstacked signal, which receivers are configured to decode.

Figure 9: Wiring the Interface Box

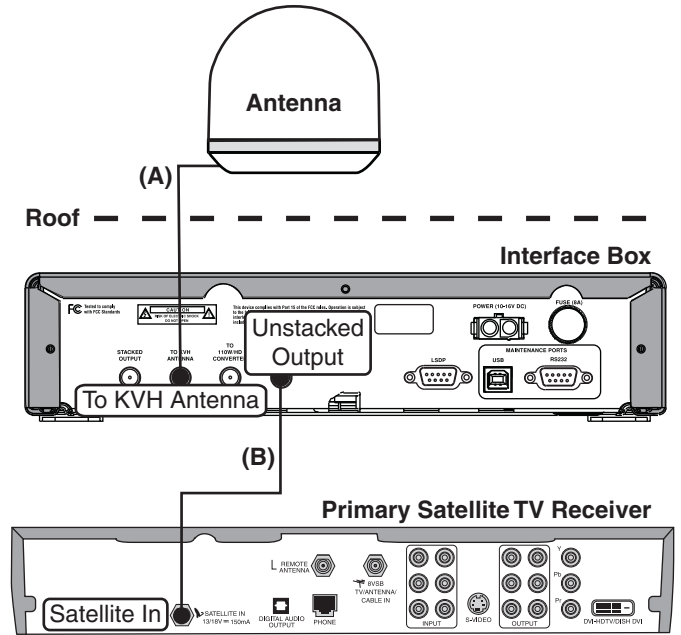
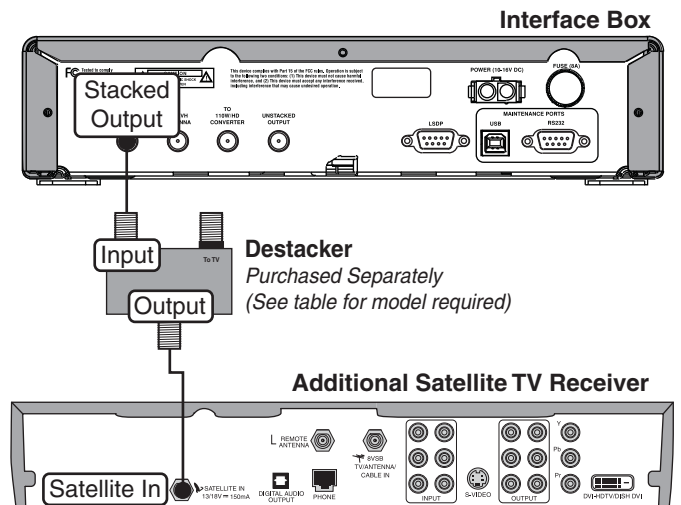

Figure 10: Destacker Models to Connect Additional Receiver(s)

# of Addl. Receivers	Destacker Model
1	Single-output (KVH part #19-0347)
2	Dual-output (KVH part #19-0410)

Figure 11: Connecting an Additional Receiver



7 Connect Power

The interface box requires 10-16 VDC power input supporting 50 watts (4.2 amps @ 12 VDC). Follow these steps to connect power to the interface box.



CAUTION

For your own safety, shut down vehicle power before you connect the wires.

- Before you connect the power wires, turn off vehicle power and test the circuit to ensure no power is present.
- Connect the individual power wires to a dedicated 12 VDC circuit. Connect the negative (black) wire to ground (power return), and connect the positive (red) wire to clean +12 VDC vehicle power.

NOTE: If vehicle power fluctuates or is noisy, KVH recommends that you use an AC/DC power supply (KVH part #72-0206-01) to provide stable power to the interface box.

- Plug the other end of the wires into the "Power" jack on the rear panel of the interface box (see Figure 12).
- Connect power to the receiver(s). Follow the instructions in the receiver's manual.

Figure 12: Interface Box Power Wiring

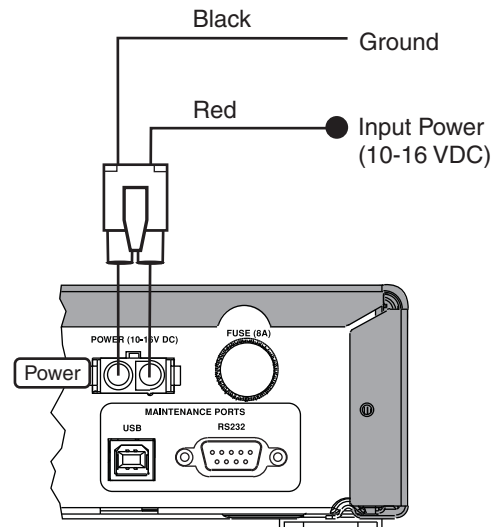

8 Mount the Interface Box

Once all cables are connected, follow these steps to install the interface box inside the vehicle.

- a. Attach the two mounting brackets to the sides of the unit using three #2-56 screws. Simply screw these fasteners into the vent slots (see Figure 13).

IMPORTANT!

To avoid overheating, do not block the upper vents of the interface box.

- b. Secure the brackets to the mounting surface using appropriate 1/4" fasteners (not supplied).

NOTE: Be sure to leave enough slack in the connecting cables (service loop) for easy serviceability.

Figure 13: Interface Box Mounting

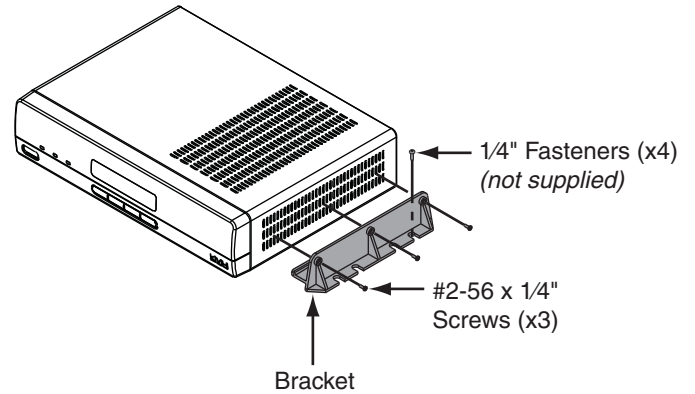

9 Turn On the System

Follow these steps to turn on the system for the first time.

- a. Ensure the antenna has a clear, unobstructed view of the sky.
- b. Apply power to the TV and receiver.
- c. Press the power switch on the front of the interface box to apply power to the TracVision system (see Figure 14).
- d. Wait while the antenna searches the sky for the satellite. Within a few minutes, all three status lights on the front of the interface box should be lit green (see Figure 14).

NOTE: If all three status lights are not lit green, refer to the User's Guide for troubleshooting information.

- e. Verify that the "System Needs Setup" screen is displayed on the interface box (see Figure 15).
- f. Using the buttons on the interface box front panel (see Figure 16), follow the steps in the next section to set up the TracVision system for the customer's service provider:

Option 1 - DISH Network (see page 12)

Option 2 - DIRECTV (see page 13)

NOTE: If you do not see an operating mode on the following pages that tracks your desired set of satellites, you can select up to five satellites in Manual mode instead. Refer to the User's Guide for details.

Figure 14: Interface Box Power Switch and Status Lights

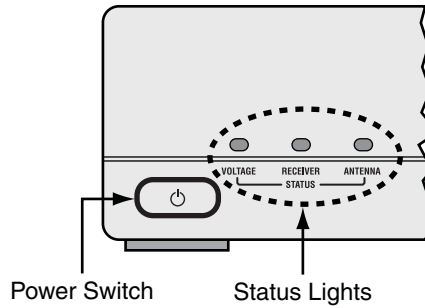

Figure 15: "System Needs Setup" Screen

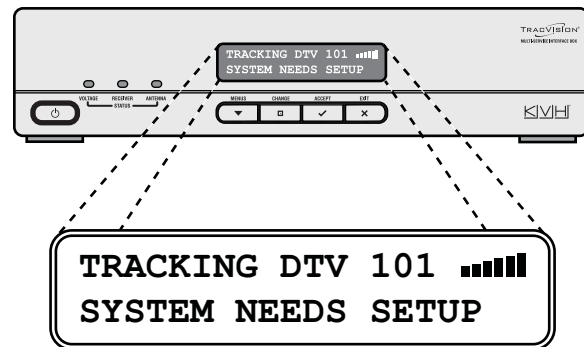
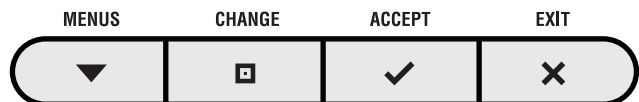

Figure 16: Interface Box Buttons



10 Set Up the System

Option 1 - DISH Network

Follow these steps and refer to the flowchart in Figure 17 to set up the system for DISH Network.

- Press any button on the interface box front panel.
- At "Service= DIRECTV?," press CHANGE until the display shows "Service= DISH." Then press ACCEPT.
- At "Mode= DISH 1000/129," press CHANGE until the display shows the desired mode. Then press ACCEPT.

You may select any one of the following DISH Network modes:

Mode	Satellites Tracked
DISH 1000/129	119, 110, and 129
DISH 1000/61	119, 110, and 61
DISH 500	119 and 110

DISH 1000/129 or DISH 1000/61

Select one of these modes for DISH Network's three-satellite service (DISH 1000). Use the map in Figure 18 to help determine the appropriate DISH 1000 mode for your geographic area. Check with DISH Network for local channels availability.

DISH 500

Select this mode if you wish to receive programming from the 119 and 110 satellites for DISH 500 service.

- Be sure to follow the instructions in Step 11 (page 14) to enter your position and Step 12 (page 15) to set up your receiver(s).

Figure 17: DISH Network Setup

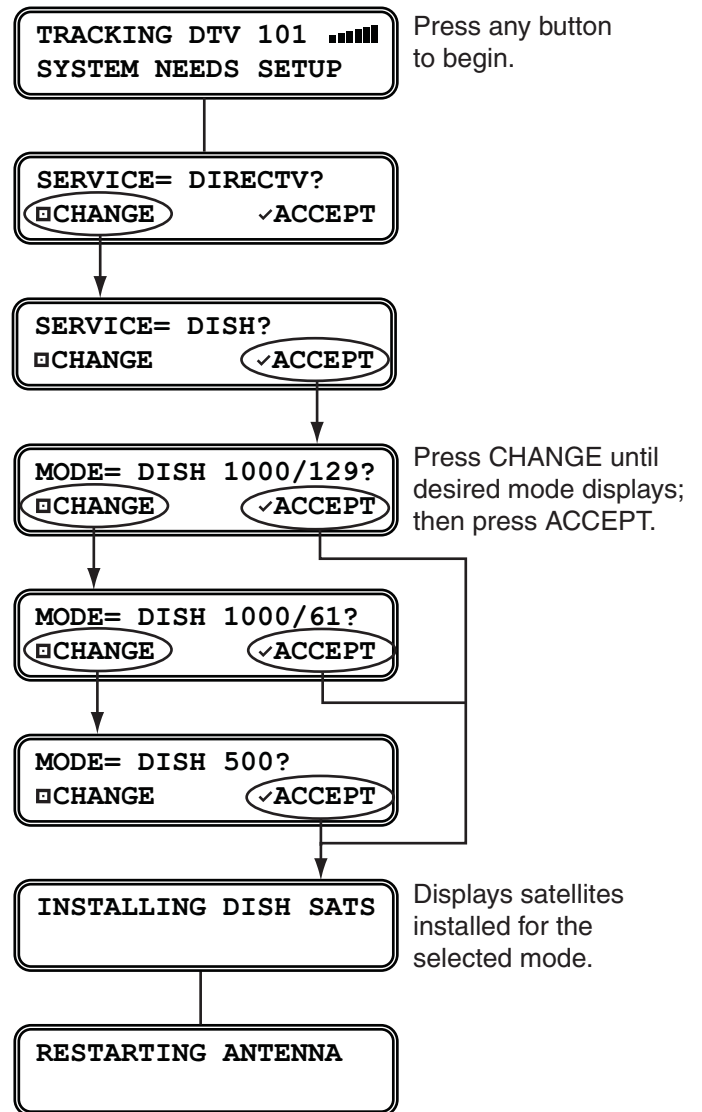
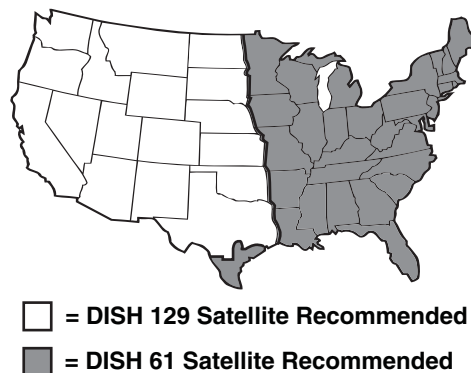

Figure 18: Recommended Areas for DISH 1000 Satellites



10 Set Up the System

Option 2 - DIRECTV

Follow these steps and refer to the flowchart in Figure 19 to set up the system for DIRECTV.

- Press any button on the interface box front panel.
- At "Service= DIRECTV?," press ACCEPT.
- At "Mode= Tri-Sat Auto," press CHANGE until the display shows the desired mode. Then press ACCEPT.

You may select any one of the following DIRECTV modes:

Mode	Satellites Tracked
Tri-Sat Auto	Not used
Tri-Sat Pairs	Not used
Dual-Sat	101 and 119

Tri-Sat Auto or Tri-Sat Pairs – Not Used

Do not use either of these modes for a new installation. The Tri-Sat Auto mode supports the Tri-Sat AutoSwitch; the Tri-Sat Pairs mode supports the HDTV Converter. These HDTV devices are no longer available.

Dual-Sat

Select this mode to receive programming from the 101 and 119 satellites for DIRECTV service.

Figure 19: DIRECTV Setup

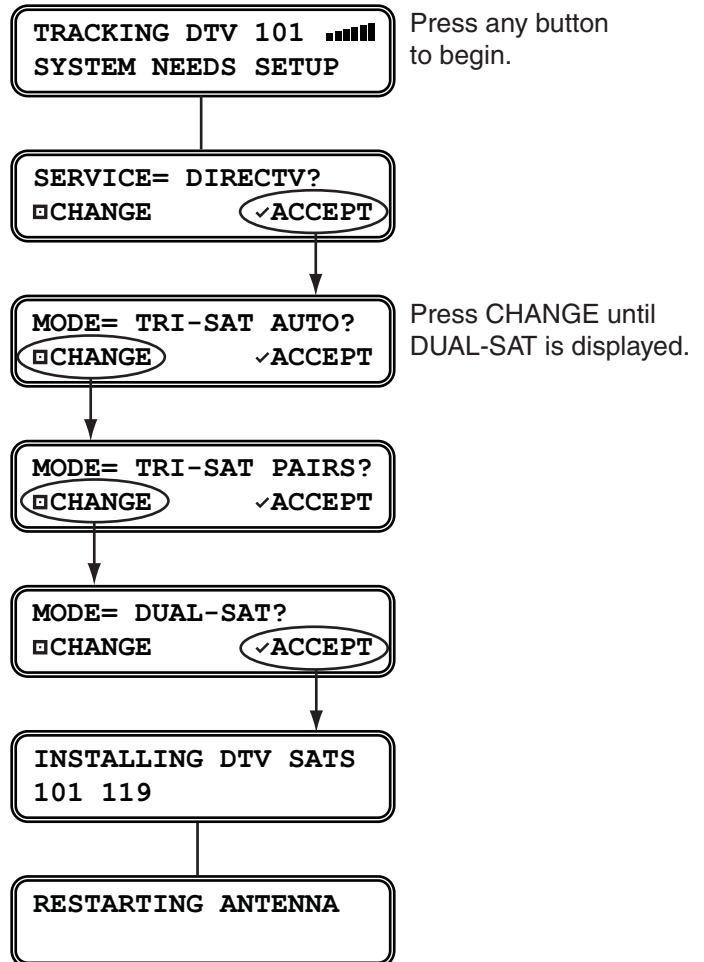

11 Enter Latitude & Longitude

Follow these steps and refer to the flowchart in Figure 20 to enter your vehicle's latitude and longitude into the system. The antenna will use your position information to speed up satellite acquisition, which is critical for DISH Network configurations. If the antenna knows where you are, it knows where it should start looking for the satellite.

If you don't know your latitude/longitude, simply use the latitude and longitude for your region shown in Figure 21. For example, if you are located in San Francisco, CA (region #11), you would enter 40° N latitude and 125° W longitude.

- Press MENUS on the interface box front panel until the display shows "Lat/Long."
- At "Lat/Long= 41N, 071W," press CHANGE.
- Press CHANGE again. A cursor appears under the first number in the displayed latitude.
- Press CHANGE until the number is set to the first digit of your vehicle's current latitude. Then press ACCEPT. The cursor moves to the next number.
- Repeat Step d to set the remaining digits (plus North/South and East/West directions) of your latitude and longitude. Once you have set the entire position, the cursor disappears from the display.
- Press ACCEPT. The antenna restarts. Wait one minute for system startup.

Figure 20: Latitude/Longitude Setting

Press MENUS until LAT/LONG is displayed.

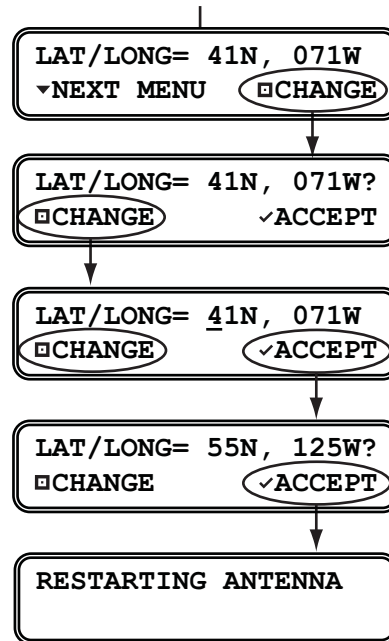

Press CHANGE to set each digit plus N/S (north or south) and E/W (east or west). Press ACCEPT to save each digit.

Figure 21: Latitude/Longitude Data for North America

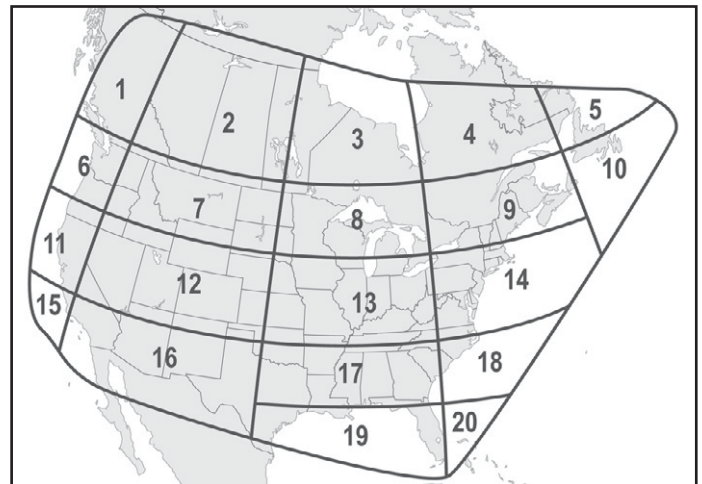

#	LAT	LONG
1	55° N	125° W
2	55° N	110° W
3	55° N	90° W
4	55° N	70° W
5	55° N	55° W
6	45° N	125° W
7	45° N	110° W
8	45° N	90° W
9	45° N	70° W
10	45° N	50° W

#	LAT	LONG
11	40° N	125° W
12	40° N	110° W
13	40° N	90° W
14	40° N	70° W
15	32° N	125° W
16	32° N	110° W
17	32° N	90° W
18	32° N	75° W
19	27° N	83° W
20	27° N	78° W

12 Run Check Switch Tests

DISH Network Only

If you set up the system for DISH Network, follow these steps to run the receiver's Check Switch test as required.

Primary Receiver - 2 Check Switch Tests

Follow these steps to run two Check Switch tests on the primary receiver, which is connected to the "Unstacked Output" jack on the interface box. This receiver will control satellite selection.

IMPORTANT!

If you purchased a **preconfigured** DISH receiver from KVH, you only need to run **one** Check Switch test to set up the system.

- a. Park the vehicle in a blockage-free area. Ensure the antenna has an unobstructed view of the sky.
- b. Apply power to the TV and receiver. (If the antenna is turned off, turn it back on and wait a few minutes for startup.)
- c. Using the receiver's remote, go to the "Point Dish/Signal Strength" screen (press MENU, 6, 1, 1 on most models).
- d. Choose **Check Switch**, then press SELECT.
- e. Choose **Test**, then press SELECT.
- f. Wait at least 15 minutes, or until the interface box shows "Please run another Check Switch," before proceeding to allow the antenna to find all of the satellites. Disregard any messages on the TV; they do not correctly indicate when the antenna is ready for the next Check Switch test.
- g. Once you have waited the proper amount of time, choose **Test**, then press SELECT to run a second Check Switch test.
- h. Refer to the tables in Figure 22 and verify the values displayed on your TV match those required for your selected mode.

If your values match, exit the menu. The receiver will download the program guide.

If your values do not match, follow the steps on the next page to reset the system before retrying this procedure.

Figure 22: Expected Check Switch Results

DISH 1000/129 Results

Port	1	2	3
Satellite	119	110	129
Trans	OK	OK	OK
Status	Reception Verified		
Switch	SW64		

DISH 1000/61 Results

Port	1	2	3
Satellite	119	110	61.5
Trans	OK	OK	OK
Status	Reception Verified		
Switch	SW64		

DISH 500 Results

Input	1	1	2	2
Satellite	119	119	110	110
Polarity	Odd	Even	Odd	Even
Status	Reception Verified			
Switch	SW42			

12 Continued Run Check Switch Tests

DISH Network Only

Resetting the System Before Retrying

If the receiver Check Switch results displayed on the TV do not match the expected values shown in Figure 22 on page 15, follow these steps and refer to the flowchart in Figure 23 to reset and reconfigure the system.

- On the interface box, press MENUS until the display shows "Diagnostics= No."
- Press CHANGE until the display shows "Diagnostics = Yes." Then press ACCEPT.
- At "System Reset= No," press CHANGE until the display shows "System Reset = Yes." Then press ACCEPT.
- At "Reset to Factory?," press ACCEPT.
- Wait a few minutes for the system to reset to its factory conditions.
- When the display shows "System Needs Setup," repeat the setup procedure on page 12.
- Be sure the vehicle is parked in a blockage-free area, and make certain the antenna has a clear, unobstructed view of the sky.
- Repeat the Check Switch steps on page 15.

Additional Receiver(s) - 1 Check Switch Test

If you connected multiple receivers, follow these steps to run a Check Switch test on each additional receiver (one at a time), **unless it is a preconfigured DISH receiver**. When you are done, reconnect the receivers as before.

- Temporarily disconnect the primary receiver from the "Unstacked Output" jack.
- Connect the additional receiver to the "Unstacked Output" jack.
- Perform Steps a-e on page 15 to run a single Check Switch test on the receiver.
- Wait 15 minutes, then verify the values on the TV match the values shown in Figure 22 on page 15. If your values do not match, try running another Check Switch test.

Figure 23: Factory Reset

Press MENUS until
DIAGNOSTICS= No is displayed.

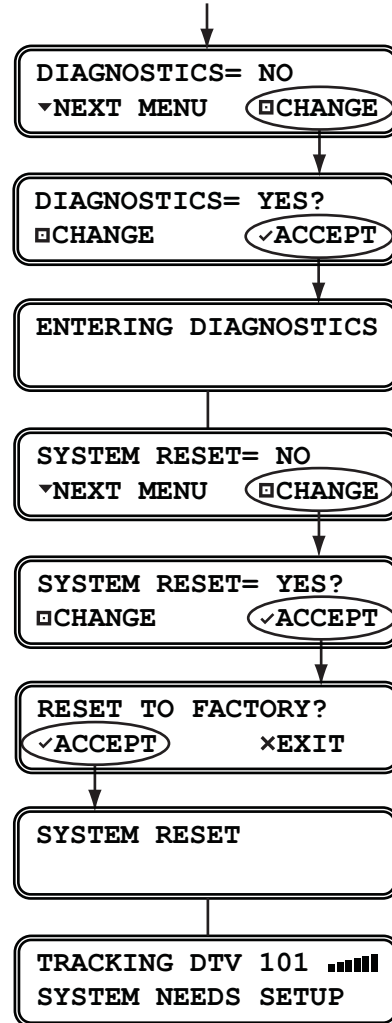

13 Educate the Customer

The installation process is complete! Before you leave the vehicle, test the system to verify the antenna works properly. Then give the Customer Welcome Kit and all manuals to the customer and explain how to use the system. Also be sure the customer understands the following:

- Keep the radome installed on the antenna at all times. The radome protects the antenna's moving parts from wind, rain, and debris.

 CAUTION
In the unlikely event that you need to remove the radome, remove power from the antenna first because the antenna's moving parts can cause injury.

 WARNING
It is dangerous to watch TV while driving a vehicle. While the vehicle is in motion, the system is intended for passenger use only.

- The receiver must be activated before it can decode satellite TV signals. Refer to Figure 24 for activation details.
- The antenna must have a clear view of the sky to receive satellite TV. Common causes of blockage include trees, buildings, bridges, overpasses, and mountains (see Figure 25). The TracVision system will not work inside a garage. Heavy rain or snow might also temporarily interrupt reception.
- Clean the antenna regularly. Dirt buildup on the radome can affect satellite TV reception.
- **(DISH 1000 only)** You may need to change the operating mode when traveling between regions (see page 12 for details).
- Please register the system with KVH. The registration process is quick, easy, online, and ensures the best possible service from KVH. Visit www.kvh.com/register or refer to the Product Registration Form for details.
- The vehicle must be located within the selected satellite's coverage area. To view satellite coverage maps, visit: www.kvh.com/footprint.

Figure 24: Receiver Activation

Service:	Call to Activate:
DISH	1-866-399-8509 (Mon.-Fri., 8:30 am - 5 pm ET)
DIRECTV	1-866-551-8004 (24 hours, 7 days a week)

Figure 25: Blockage Example

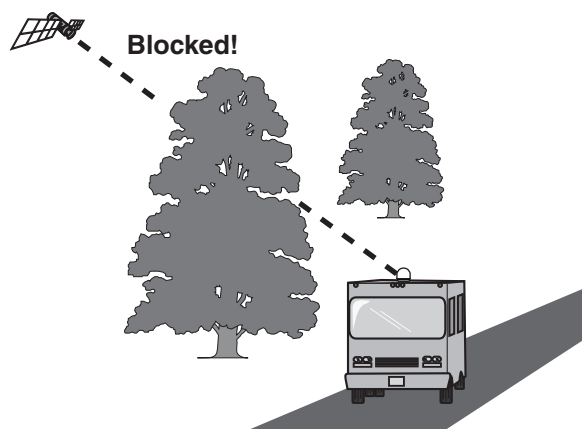



KVH Industries, Inc.
World Headquarters
Middletown, RI U.S.A.
Tel: +1 401 847 3327 Fax: +1 401 849 0045
E-mail: info@kvh.com

KVH Europe A/S
EMEA Headquarters
Kokkedal, Denmark
Tel: +45 45 160 180 Fax: +45 45 160 181
E-mail: info@emea.kvh.com

KVH Singapore
Asian Headquarters
Singapore
Tel: +65 6513 0290 Fax: +65 6472 3469
E-mail: info@asia.kvh.com

KVH Norway AS
Horten, Norway
Tel: +47 33 03 05 30 Fax: +47 33 03 05 31
E-mail: info@no.kvh.com