

TracVision® HD7 SWM Expansion Kit

These instructions explain how to install a SWM (single-wire multiswitch) expander kit for use with the TracVision HD7. With the SWM expander installed, the TracVision HD7 supports 16 or 32 tuners, allowing you to connect even more DVRs/receivers to the TracVision HD7 system. Complete instructions on how to use the system are provided in the User's Guide.

Installation Steps

- | | | | |
|--|---|--------------------------------------|----|
| 1. Inspect Parts and Get Tools | 3 | 6. Assemble the SWM Expander | 9 |
| 2. Remove the Radome | 4 | 7. Wire the SWM Expander..... | 10 |
| 3. Wire the SWM Bypass Bracket | 5 | 8. Connect Receivers/DVRs..... | 12 |
| 4. Install the SWM Bypass Bracket..... | 7 | 9. Configure Each Receiver/DVR | 13 |
| 5. Connect Cables to the Antenna | 8 | | |

Who Should Install the System?

To ensure a safe and effective installation, KVH recommends that a KVH-authorized marine technician install the TracVision antenna and accessories. KVH-authorized technicians have the tools and electronics expertise necessary to install the system. To find a technician near you, visit www.kvh.com/wheretogetservice.

Technical Support

If you need technical assistance, please contact KVH Technical Support:

Phone: +1 401 847-3327

E-mail: techs@kvh.com

(Mon.-Fri., 9 am - 6 pm Eastern)

(Sat., 9 am - 2 pm Eastern)

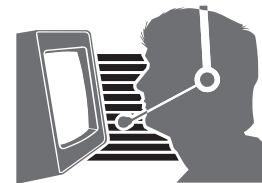

1 Inspect Parts and Get Tools

Before you begin, follow the steps below to ensure you have everything needed to complete the installation.

- a. Unpack the box and ensure it contains everything shown on the Kitpack Contents List. Save the packaging for future use.
- b. Carefully examine all of the supplied parts to ensure nothing was damaged in shipment.
- c. Gather the tools and materials listed below. You will need these items to complete the installation.
 - #1 flat-head screwdriver
 - #2 Phillips screwdriver
 - 5/8" open-end wrench
 - 1/2" open-end wrench
 - 7/16" open-end wrench
 - RG-6 or RG-11 RF coax cabling with Snap-N-Seal[®] F-connectors (see [Figure 1](#))
 - Satellite TV receivers and/or DVRs (Refer to the TracVision HD7 Installation Guide for complete details)
 - Silicone sealant, self-vulcanizing tape, or equivalent

Figure 1 RF Cable Type Requirements

For Lengths	Use RF Cable Type
Up to 100 ft. (30 m)	RG-6
100 ft. (30 m) to 200 ft. (60 m)	RG-11

NOTE: The RF cables connecting the antenna to the SWM expander should not exceed 100 ft. (30 m) in length. Only RF cables connecting the 8-way splitters, receivers, and DVRs can be wired over 100 ft. (30 m) (up to 200 ft. (60 m)).

2 Remove the Radome

TracVision HD7 Standard Dome Version

- Using a #2 Phillips screwdriver, remove the six #10-32 Phillips screws securing the radome to the baseplate (see Figure 2).
- Carefully lift the radome straight up off the antenna. Then set it aside in a safe place.

TIP: If you keep the radome topside, secure it with a lanyard to prevent it from falling overboard.

TracVision HD7 Large Dome Version (32-inch (82 cm))

- Using a #2 Phillips screwdriver, remove the eleven M4 screws securing the service hatch to the antenna's baseplate (see Figure 3). Set the hatch aside in a safe place.
- Using a #2 Phillips screwdriver, remove the eight #10-32 Phillips screws securing the radome to the baseplate (see Figure 4).
- Carefully lift the radome straight up off the antenna. Then set it aside in a safe place.

TIP: If you keep the radome topside, secure it with a lanyard to prevent it from falling overboard.

Figure 2 Radome Screws (Standard Dome)

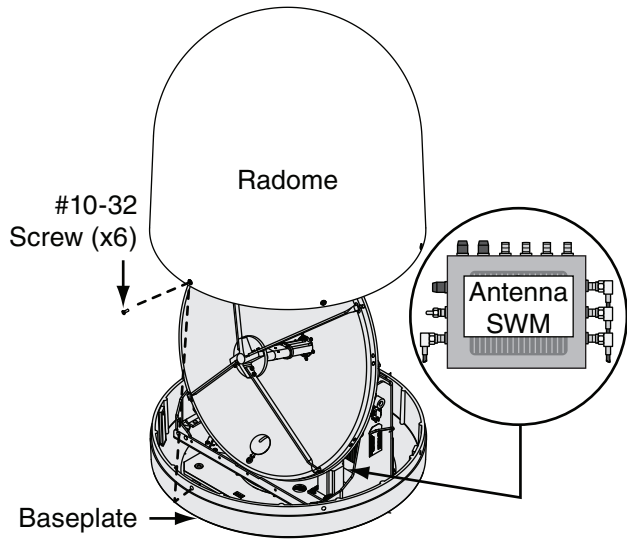

Figure 3 Service Hatch Screws (Large Dome)

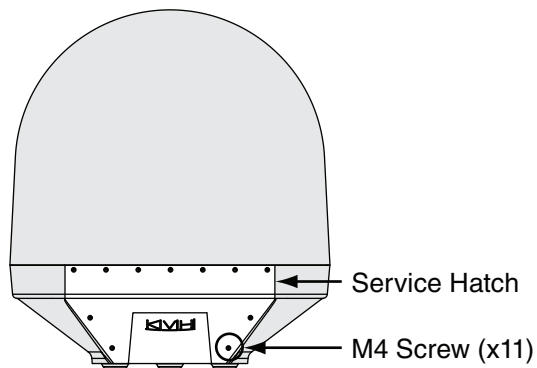
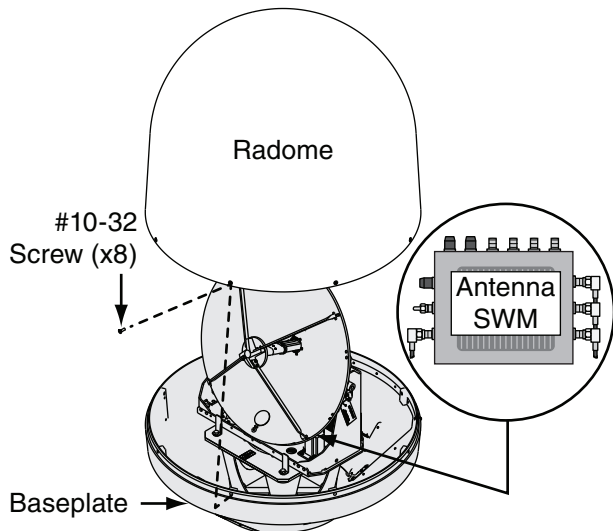

Figure 4 Radome Screws (Large Dome)



3 Wire the SWM Bypass Bracket

Follow the instructions below to bypass the antenna SWM by wiring the SWM bypass bracket.

- Locate the SWM inside the antenna (see [Figure 2](#) or [Figure 4](#) on page 4).
- Apply the “RF1” label, supplied in the kitpack, to the end of the RF1 cable (see [Figure 5](#)).
- Using a 7/16" open-end wrench, carefully disconnect each of the cables shown in [Figure 5](#), and connect them, one at a time, to the corresponding connectors on the SWM bypass bracket.
- Ensure the cables are arranged neatly. Tilt the reflector upward and downward, through its full range of movement, to ensure the cables do not inhibit its movement.

NOTE: To avoid damage, avoid excessive twisting or sharp bends in the cables while tightening.

Figure 5 SWM Bypass Bracket Wiring

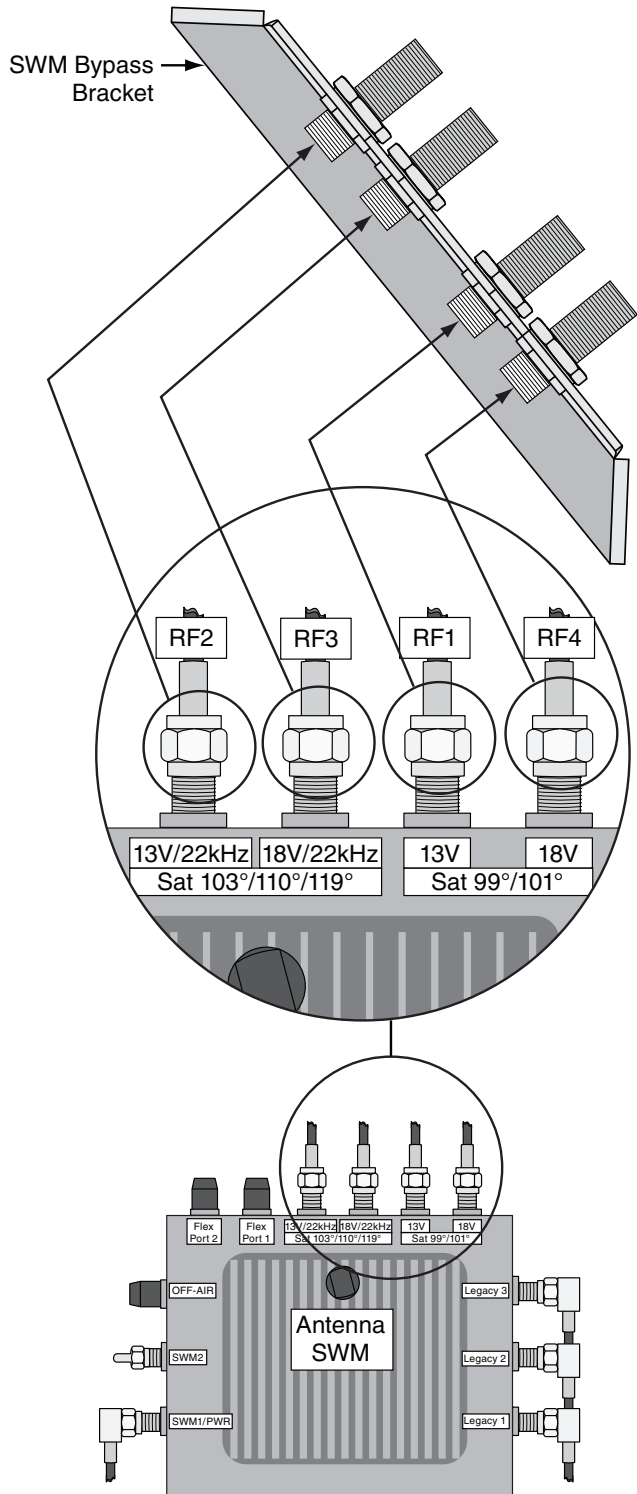

3 Continued Wire the SWM Bypass Bracket

- e. Using 7/16" open-end wrench, carefully disconnect each of the cables shown in Figure 6 and connect them, one at a time, to the corresponding connectors on the other side of the bracket.

Figure 6 SWM Bypass Bracket Wiring

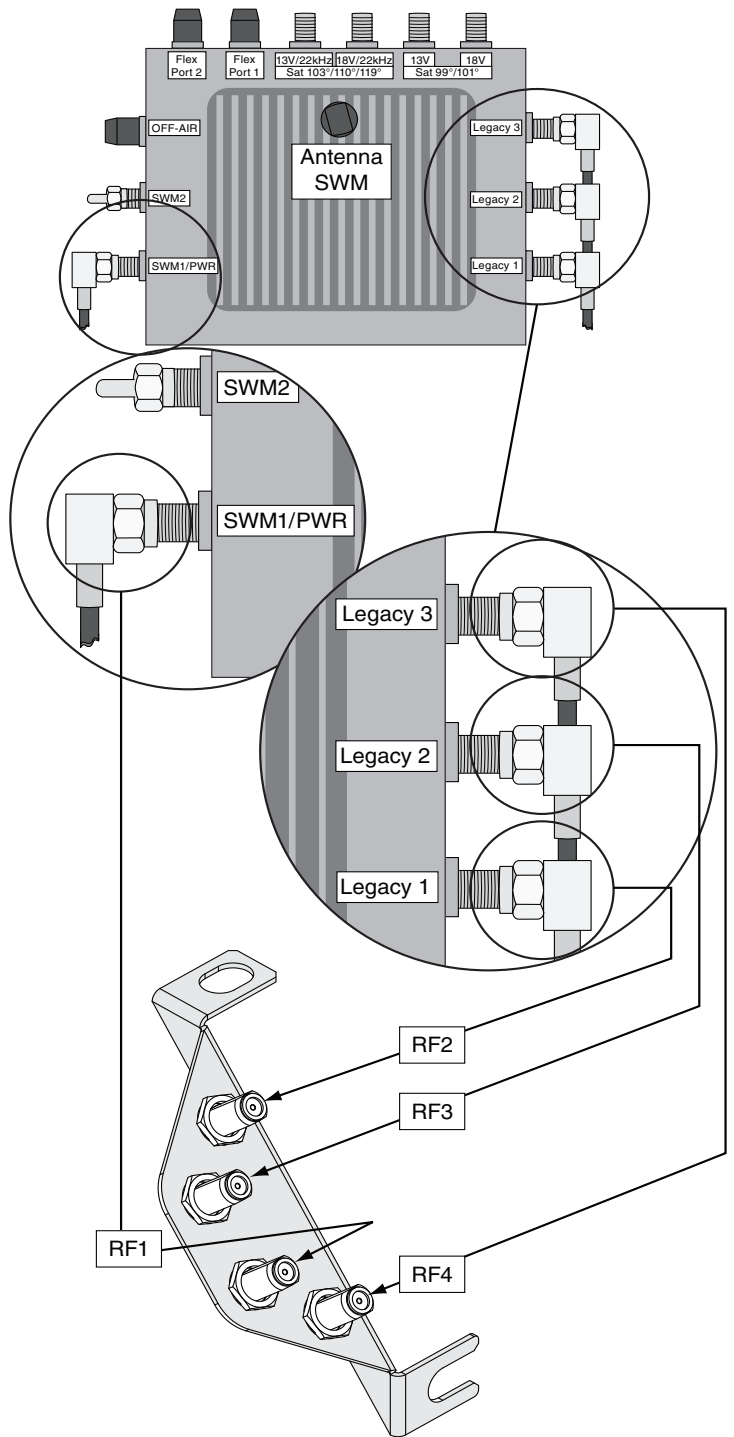

4 Install the SWM Bypass Bracket

Follow the steps below to install the SWM bypass bracket.

NOTE: For illustrative purposes, the bracket is shown without connected cables.

- a. Mount the SWM bypass bracket onto the SWM connectors, as shown in [Figure 7](#).
- b. Using a 1/2" open-end wrench, secure the bracket into place using the two supplied 3/8" nuts and star washers supplied in the kitpack, as shown in [Figure 8](#).

NOTE: Be sure to neatly arrange the cables, ensuring the reflector can travel through its full range of motion.

- c. Reinstall the radome and service hatch (if required) that you removed earlier.

Figure 7 SWM Bypass Bracket Installation

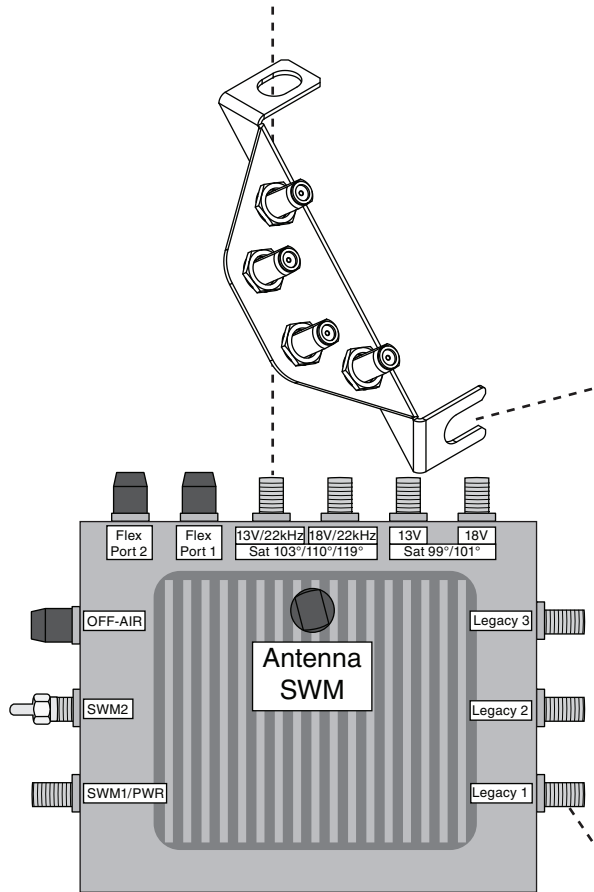
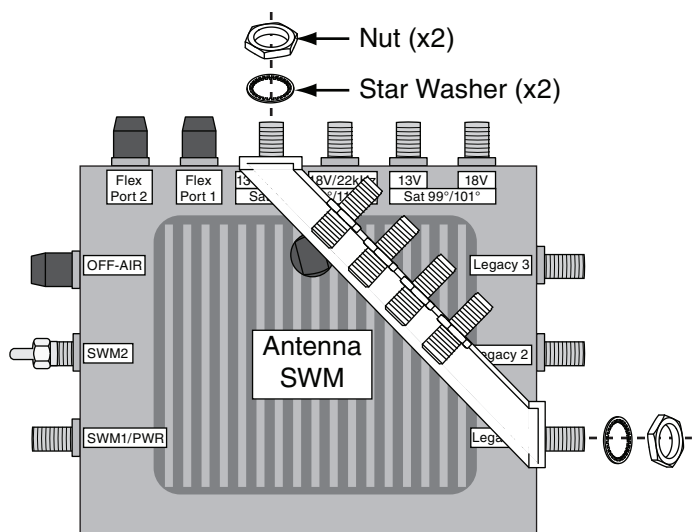

Figure 8 SWM Bypass Bracket Hardware



5 Connect Cables to the Antenna

Follow the instructions below to connect cables to the RF connectors on the bottom of the antenna (see [Figure 9](#)).

- a. Connect RF cables to the antenna's SWM (RF1), RF2, RF3, and RF4 connectors (see [Figure 9](#)) and hand-tighten. Then, using a 7/16" open-end wrench, tighten the RF cables for 1/4 turn.
- b. Label the ends of the cables for easy identification later.
- c. Seal the RF cable connections with silicone sealant, self-vulcanizing tape, or equivalent.
- d. Route the cables belowdecks through the cable access hole. Leave an adequate service loop, approximately 8" (20 cm) of slack, in the cables for easy serviceability.

Figure 9 Connectors on the Bottom of Antenna Assembly

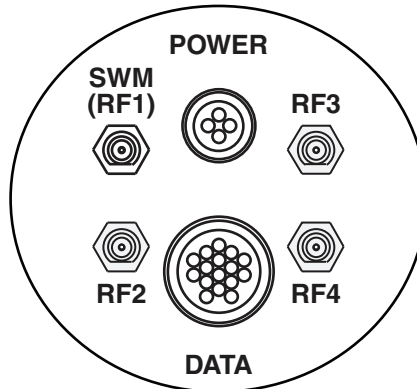

6 Assemble the SWM Expander

Now you need to assemble the SWM expander components supplied in the kitpack.

- Some SWMs include both connector caps and weather-tight seals on the connectors (see [Figure 10](#)). Remove these caps (and seals, if equipped) to ensure a proper connection with the expander in the following steps.
- Follow the instructions supplied with the SWM components to assemble the expander, as shown in [Figure 11](#) or [Figure 12](#).
- Using the supplied mounting screws, secure the SWM expander assembly to the mounting surface.

NOTE: To ensure proper power/signal quality, be sure to mount the SWM expander within 100 ft. of the antenna.

Figure 10 Weather-tight Seal Removal

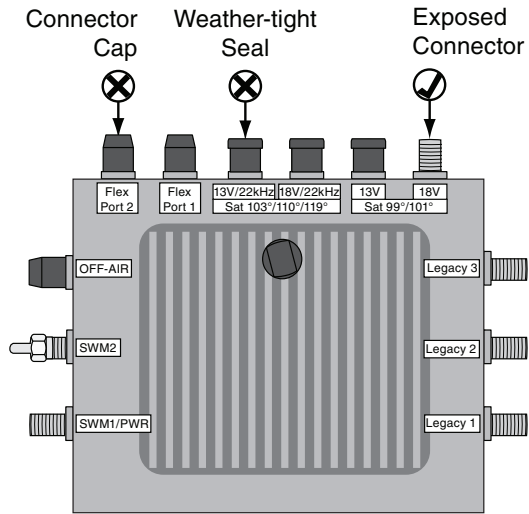

Figure 11 Expander Assembly (16 Tuner Version)

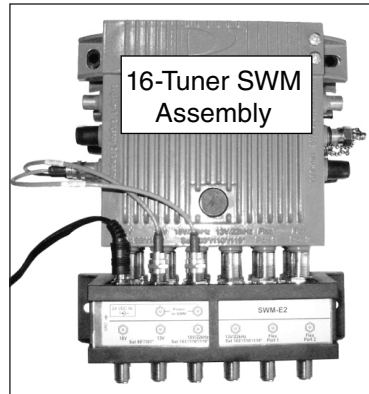
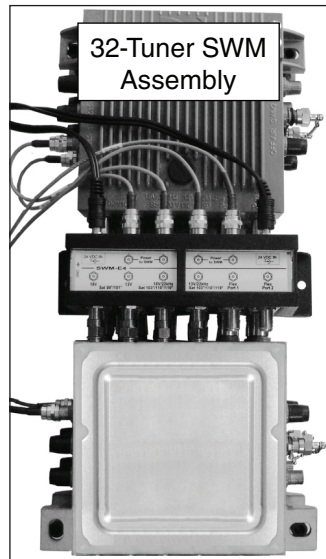

Figure 12 Expander Assembly (32 Tuner Version)



7

Wire the SWM Expander

Follow the instructions below to connect the antenna to the SWM expander, and connect the supplied SWM splitters.

Connect RF Cables from the Antenna

Connect the antenna's SWM (RF1), RF2, RF3, and RF4 cables to the SWM expander connectors, **exactly** as shown in [Figure 13](#).

IMPORTANT!

Be sure to wire the RF cables exactly as shown in [Figure 13](#). Failure to wire the cables correctly will impair performance.

Connect and Ground 8-Way Splitters

- Connect one end of an RF cable to a "SWM1/PWR" connector on the SWM expander. Then connect the other end to the supplied splitter, as shown in [Figure 14](#) or [Figure 15](#) on page 11.
- Using the screws supplied with the splitter, secure the splitter to an appropriate mounting surface.
- Using a #1 flat-head screwdriver, fasten one end of the 25 ft (30 m) ground wire (supplied/installed with the antenna) to the expander's grounding screw. Connect the other end of the ground wire to a suitable AC ground.
- If you are installing a 16-tuner SWM expander, repeat steps a-b to connect the second supplied splitter (see [Figure 14](#)).

Figure 13 Antenna RF Cable Connections

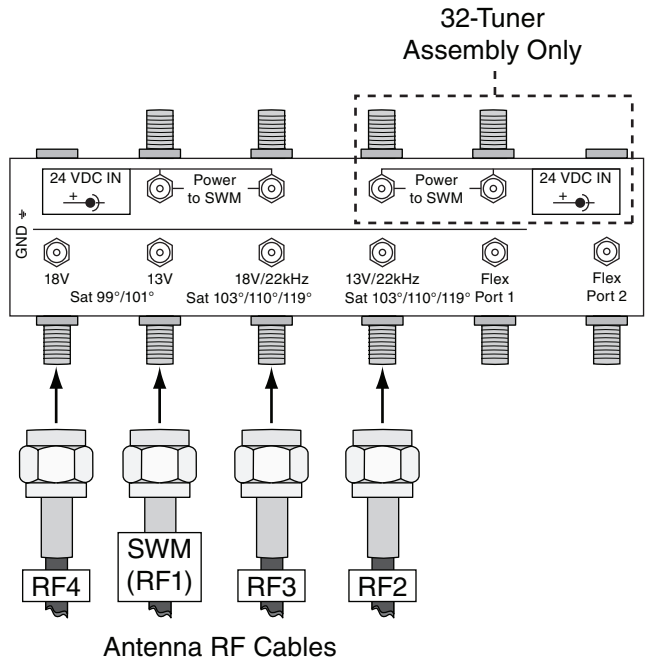
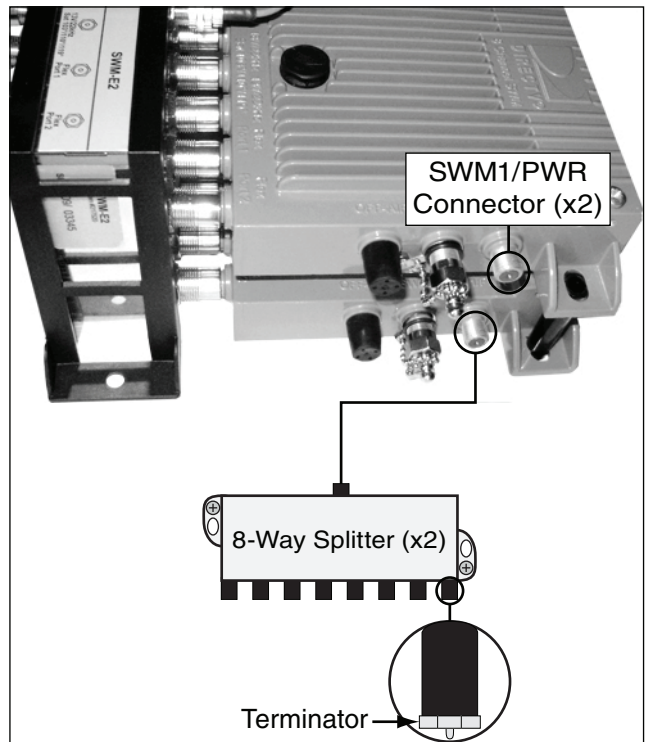

Figure 14 Splitter Connections (16-Tuner Version)



7

Continued Wire the SWM Expander

- e. If you are installing a 32-tuner SWM expander, repeat steps a-b to connect the three additional supplied splitters (see Figure 15).

Figure 15 Splitter Connections (32-Tuner Version)

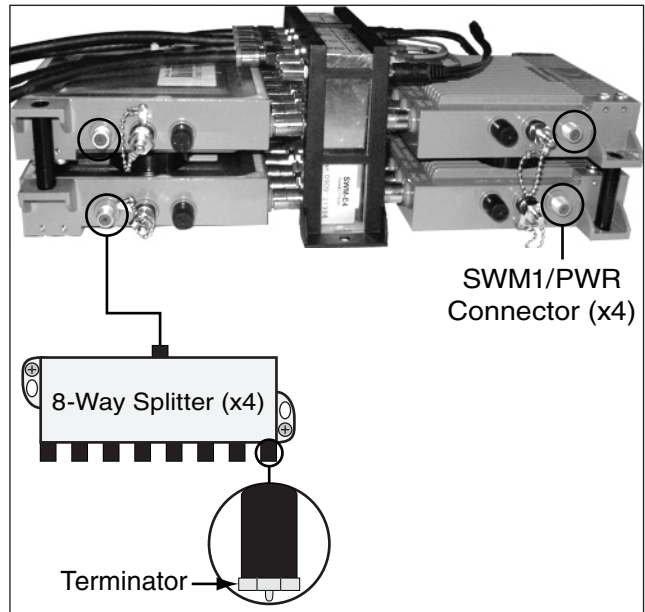

8 Connect Receivers/DVRs

Now you need to connect the receivers and/or DVRs to the 8-way splitters. Consider the following connection guidelines before you begin:

- Refer to the wiring diagrams in [Figure 16](#) and [Figure 17](#) to connect receivers/DVRs to each 8-way splitter.
- Since each 8-way splitter supports up to 8 tuners, you can connect any number of SWM receivers/DVRs that adds up to 8 tuners or fewer.
- Each receiver has a single tuner, and requires one RF cable. Each DVR has two tuners, and requires one RF cable.
- Connector labeling might vary between receiver and DVR models. Refer to the User's Guide for your selected receivers/DVRs for complete information.
- Always terminate any unused splitter connectors with a supplied terminator (see [Figure 15 on page 11](#)).

Figure 16 Receiver Wiring

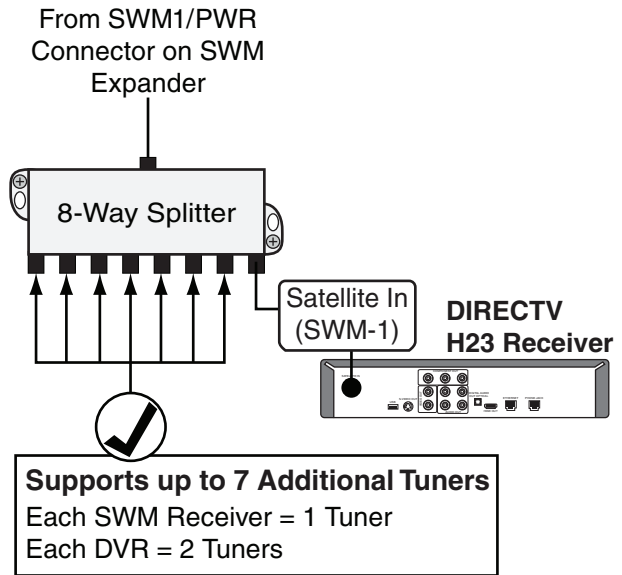
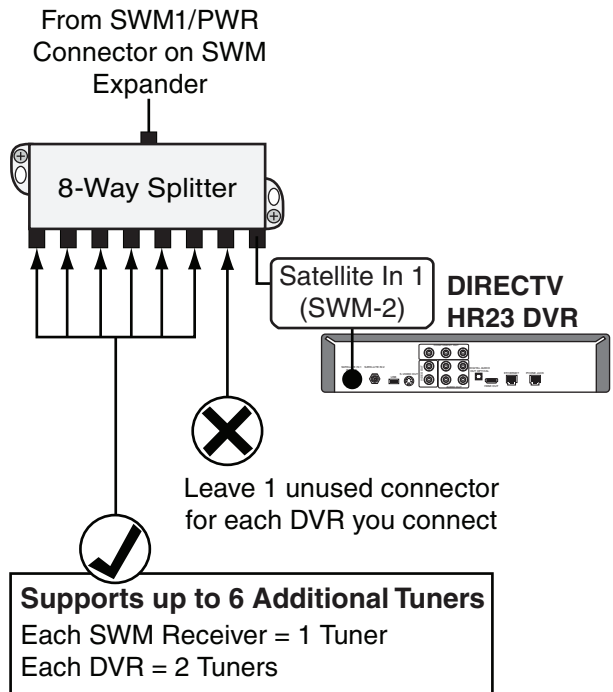

Figure 17 DVR Wiring



9 Configure Each Receiver/DVR

Follow the steps below to configure each SWM receiver/DVR.

Power On Connected Components

Plug in and turn on any connected receivers, DVRs, and televisions.

Set Each DIRECTV Receiver/DVR to Dish Type: Slimline-3

- a. Press the Menu button on the receiver's/DVR's remote control to display its menu on the connected television.

NOTE: Refer to your selected receiver/DVR manual for specific configuration instructions.

- b. At the "Satellite Dish Setup" menu, set the Dish Type to **Slimline-3**. Then choose **Continue** (see [Figure 18](#)).
- c. Repeat this procedure for each connected receiver/DVR.

The procedure is complete!

Figure 18 SWM Receiver/DVR Configuration

