

TracVision® HD7



Installation Guide

KMH Industries, Inc.

TracVision® HD7 Installation Guide

These instructions explain how to install the TracVision HD7 satellite TV antenna system (with the alternate, 35" (90 cm) dome) on a vessel. Complete instructions on how to use the system are provided in the User's Guide.

Installation Steps

- | | | | |
|---|----|--|----|
| 1. Inspect Parts and Get Tools | 3 | 9. Remove the Shipping Restraints | 12 |
| 2. Plan the Antenna Installation | 4 | 10. Mount the ACU | 13 |
| 3. Plan the ACU Installation | 5 | 11. Wire the ACU..... | 15 |
| 4. Determine RF Cable Requirements..... | 6 | 12. Wire Supplied Components..... | 16 |
| 5. Prepare the Antenna Site..... | 7 | 13. Configure Each Receiver/DVR | 18 |
| 6. Remove the Hatch and Radome..... | 8 | 14. Connect the ACU to the Network..... | 19 |
| 7. Wire the Antenna | 9 | 15. Update the Software if Necessary | 23 |
| 8. Mount the Antenna | 11 | 16. Educate the Customer..... | 24 |

Who Should Install the System?

To ensure a safe and effective installation, KVH recommends that a KVH-authorized marine technician install the TracVision antenna. KVH-authorized technicians have the tools and electronics expertise necessary to install the system. To find a technician near you, visit www.kvh.com/wheretogetservice.

Technical Support

If you need technical assistance, please contact KVH Technical Support:

Phone: +1 401 847-3327

E-mail: techs@kvh.com

(Mon.-Fri., 9 am - 6 pm Eastern)

(Sat., 9 am - 2 pm Eastern)

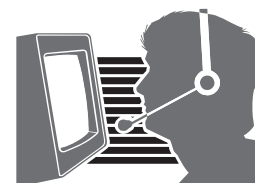

1 Inspect Parts and Get Tools

Before you begin, follow the steps below to ensure you have everything needed to complete the installation.

- a. Unpack the box and ensure it contains everything shown on the Kitpack Contents List. Save the packaging for future use.

IMPORTANT!

Always lift the antenna by the baseplate and never by the radome or any portion of the internal antenna assembly (see [Figure 1](#)).

- b. Carefully examine all of the supplied parts to ensure nothing was damaged in shipment.
- c. Gather the tools and materials listed below. You will need these items to complete the installation.

- #0 Flat-head screwdriver
- #1 Phillips screwdriver
- #2 Phillips screwdriver
- Electric drill and 1/2" (1.3 cm) drill bit
- 2" (5 cm) hole saw
- 17 mm nut driver or wrench
- 5/8" open-end wrench
- 9/16" nut driver or wrench
- 7/16" open-end wrench
- Light hammer and center punch
- Wire strippers and terminal lug crimper
- Cutting pliers
- RG-6 or RG-11 RF coax cabling with Snap-N-Seal® F-connectors; refer to ["Determine RF Cable Requirements"](#) on page 6 for details
- Satellite TV receivers and/or DVRs
- Surge protector or uninterruptible power supply (UPS) (recommended)
- Silicone sealant, self-vulcanizing tape, or equivalent

Figure 1 TracVision HD7 Antenna

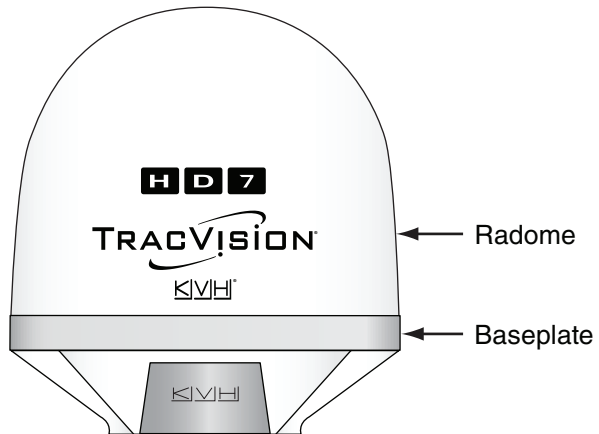

Figure 2 Antenna Control Unit (ACU)



2 Plan the Antenna Installation

Before you begin, consider the following antenna installation guidelines:

- The antenna must be mounted outside the radar's beam pattern.

IMPORTANT!

Do not mount the antenna at the same level as the radar because the radar's energy will overload/damage the antenna's LNB.

- Minimize blockage. The antenna requires a clear view of the sky to receive satellite TV (see Figure 3). The fewer obstructions, the better the system will perform.
- Make sure the mounting surface is wide enough to accommodate the antenna's base (see Figure 4). Also make sure it is flat, level (within $\pm 1^\circ$), strong enough to support the antenna's weight (95 lbs (43 kg)), and rigid enough to withstand vibration.
- Select a location that is as close as possible to the intersection of the vessel's fore-and-aft centerline and midships.
- The antenna must be located within 100 ft (30 m) of the ACU.

Figure 3 Blockage from Obstruction

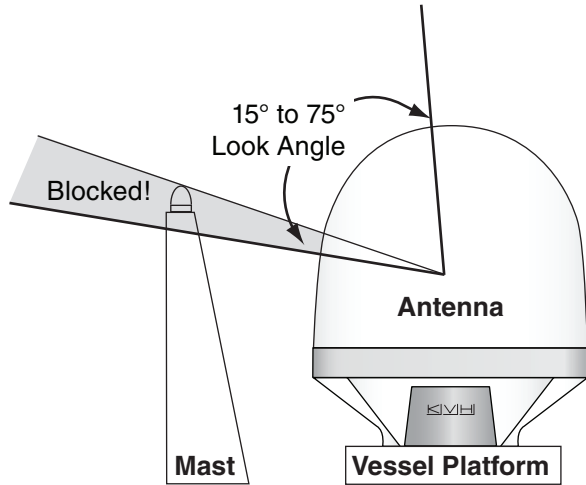
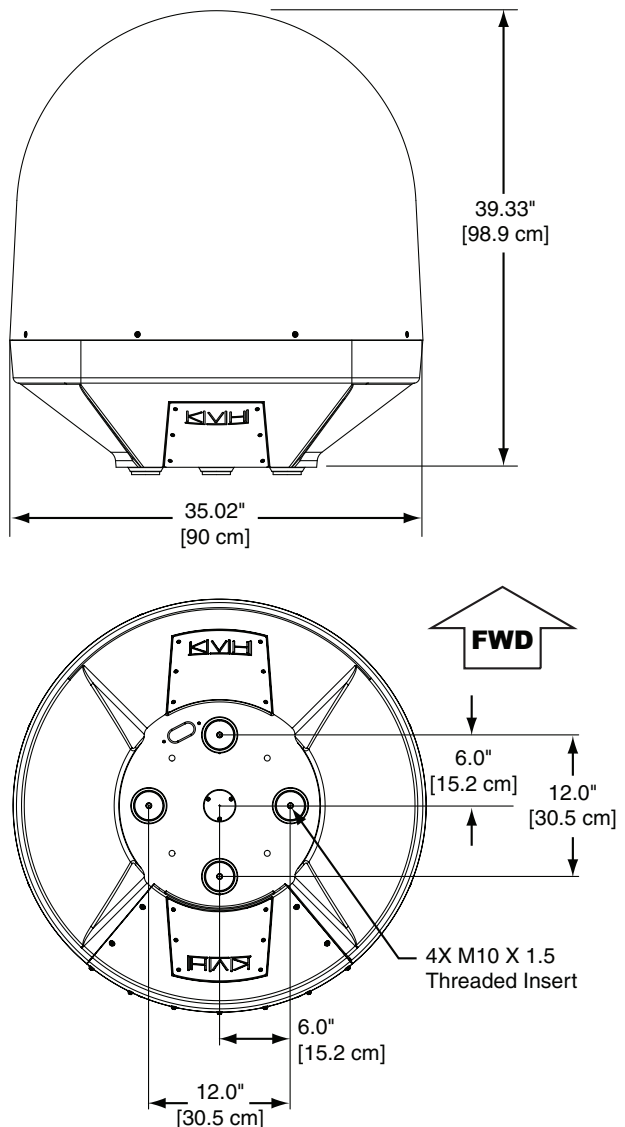

Figure 4 Antenna Dimensions



3 Plan the ACU Installation

Before you begin, consider the following ACU installation guidelines:

- Select an ACU mounting location in a dry, well-ventilated area belowdecks away from any heat sources or salt spray.
- The ACU's front panel should be easily accessible to the user.
- Ensure the ACU mounting location provides adequate WiFi reception. Do not install it in an area surrounded by metal or near any electrical devices that emit RF noise.
- The ACU must be located within 100 ft (30 m) of the antenna.
- You can choose from two ACU mounting options:

Option A - Equipment Rack Mounting

If desired, you can mount the ACU in a standard 19" (48.26 cm) equipment rack.

NOTE: The ACU is 1.5U in height.

Option B - Horizontal Surface Mounting

If desired, you can remove the rack-mount brackets from the front panel of the ACU, and secure the ACU underneath or on top of a horizontal surface using the supplied horizontal mounting brackets.

Figure 5 ACU Dimensions

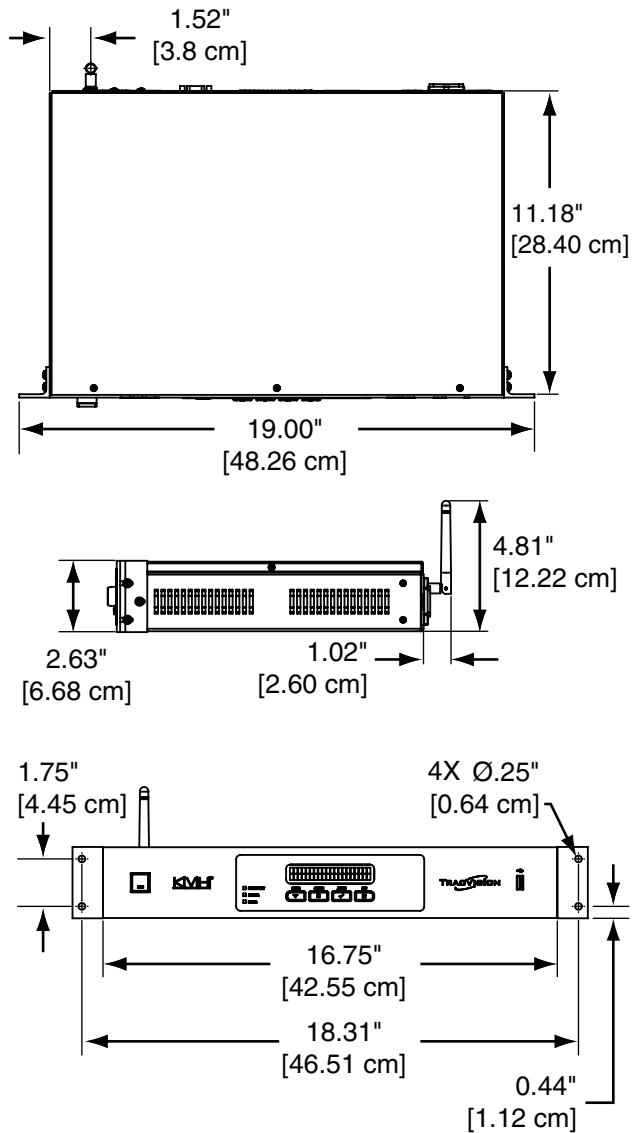

4 Determine RF Cable

Follow the instructions below to determine the quantity and type of RF cables needed.

What Type of RF Cables are Needed?

To ensure optimal performance, refer to the table below to select the required RF cable type for your installation.

| For Lengths | Use RF Cable Type |
|--------------------------------|-------------------|
| Up to 100 ft (30 m) | RG-6 |
| 100 ft (30 m) to 200 ft (60 m) | RG-11 |

NOTE: Only use RF cable lengths 200 ft (60 m) or shorter. One 100 ft (30 m) RG-11 RF cable is supplied with the TracVision HD7 system.

How Many RF Cables are Needed?

The number of RF cables varies according to the quantity of receivers and/or DVRs. Consider the following guidelines.

- Since the 8-way splitter supports up to 8 tuners, you can connect any number of SWM receivers/DVRs that adds up to 8 tuners or fewer.
- Each receiver has a single tuner, and requires one RF cable. Each DVR has two tuners, and requires one RF cable.
- If you wish to support more than 8 tuners, you can purchase a 16-tuner SWM Expander Kit (KVH part #72-0452-01) or a 32-tuner SWM Expander Kit (KVH part #72-0452-02).

What Type of RF Cable Connectors are Needed?

Be sure to use only Snap-N-Seal F-type connectors. Twist-on connectors and other low-quality connector types degrade performance.

Figure 6 Wiring Overview

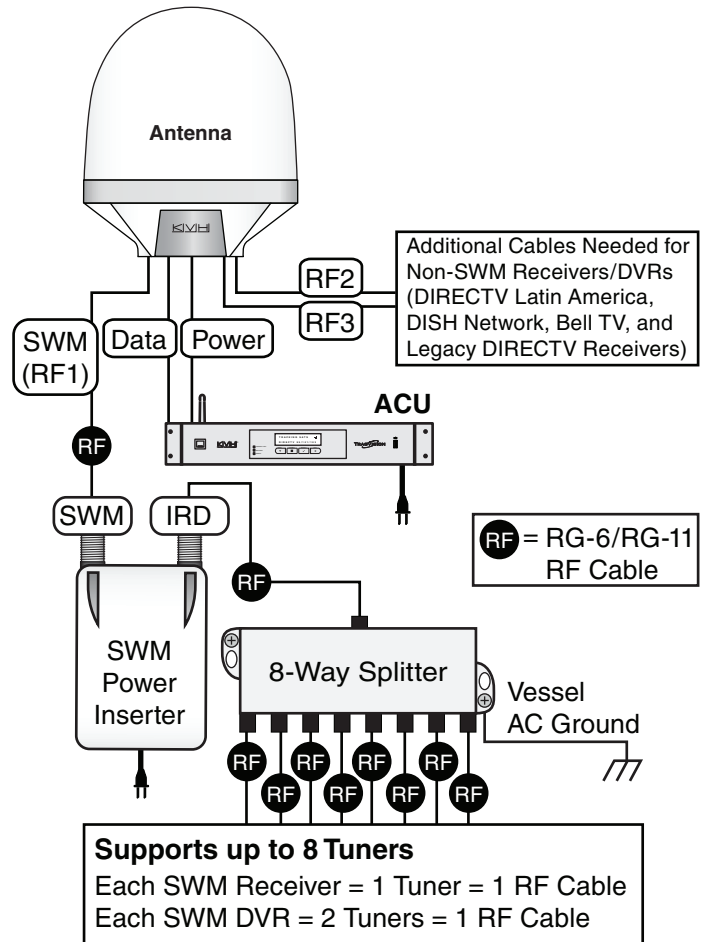

NOTE: Refer to “Wire Supplied Components” on page 16 for complete receiver/DVR connection instructions. Refer to “Wiring Non-SWM Receivers” on page 29 for complete non-SWM connection instructions.

5 Prepare the Antenna Site

Follow the steps below to drill the antenna's mounting holes and cable access hole. You will route all of the antenna cables through this access hole later.

- Unfold the antenna mounting template (supplied in the Customer Welcome Kit) and place it onto the mounting surface. Make sure the "FWD" (forward) arrow points toward the bow and is parallel to the vessel's centerline (see Figure 7).
- Using a light hammer and center punch, mark the locations for the four mounting holes and cable access hole on the mounting surface in the locations indicated on the template.
- Drill a 1/2" (1.3 cm) hole at the four mounting hole locations. Later, you will insert four 3/8"-16 bolts through these holes to secure the antenna to the mounting surface.
- Using a 2" (5 cm) hole saw, cut out the cable access hole. Smooth the edges of the hole to protect the cables. Later, you will route the cables through this hole and into the vessel.
- Clean and dry the antenna mounting surface.
- Peel off the paper backing from the supplied foam seal to expose the adhesive.
- Press the foam seal down firmly onto the mounting surface (not the antenna's baseplate), ensuring the hole in the foam seal aligns with the cable access hole in the mounting surface (see Figure 8).

NOTE: Apply the foam seal to the vessel mounting surface, not to the antenna's baseplate. You will have difficulty connecting the cables to the antenna if the foam seal is attached to the baseplate.

Figure 7 Antenna Mounting Holes Layout

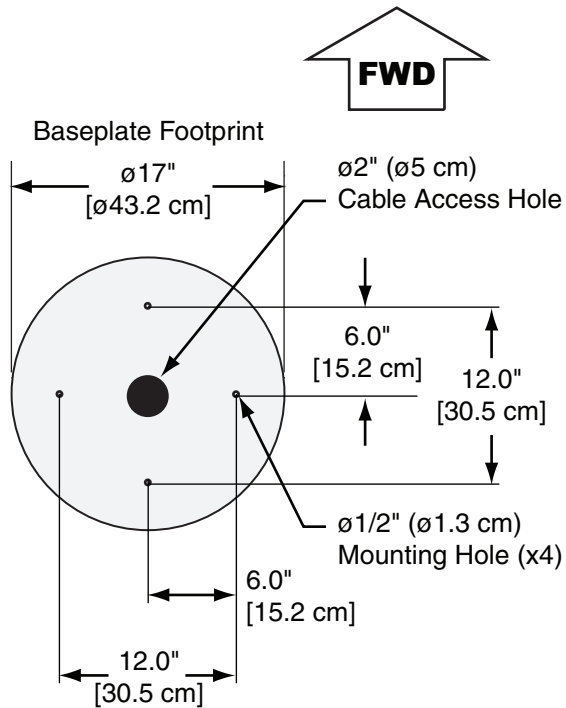

Figure 8 Foam Seal



6 Remove the Hatch and Radome

Remove the Service Hatch and Radome

Follow the steps below to remove the service hatch and radome.

- Using a #2 Phillips screwdriver, remove the eleven M4 screws securing the service hatch to the antenna's baseplate (see [Figure 9](#)). Set the hatch aside in a safe place.
- Using a #2 Phillips screwdriver, remove the eight #10-32 Phillips screws securing the radome to the baseplate (see [Figure 10](#)).
- Carefully lift the radome straight up off the antenna. Then set it aside in a safe place.

TIP: If you keep the radome topside, secure it with a lanyard to prevent it from falling overboard.

Figure 9 Service Hatch Screws

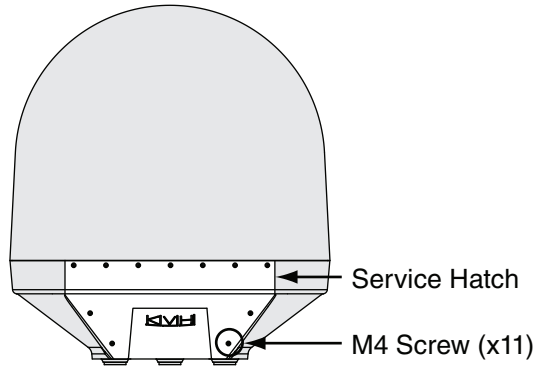
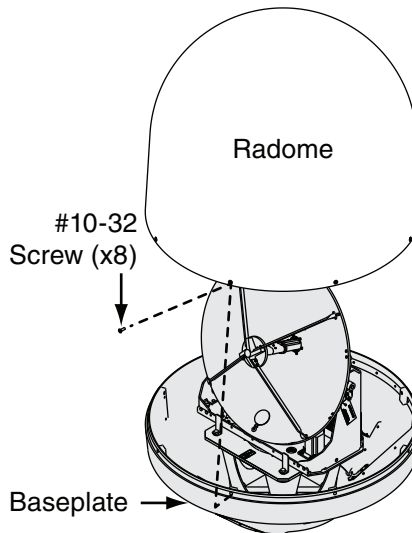

Figure 10 Radome Screws



7 Wire the Antenna

Connect the Power and Data Cables

Connect and hand-tighten the data and power cables to the antenna (see [Figure 11](#)). Then route the cables belowdecks through the cable access hole. Be sure to leave an adequate service loop, approximately 8" (20 cm) of slack, in the cables for easy serviceability.

Connect an RF Cable to SWM (RF1)

- a. Connect an RF cable to the antenna's SWM (RF1) connector. Then, using a 7/16" open-end wrench, tighten the RF cable for 1/4 turn.
- b. Seal the RF cable connection with silicone sealant, self-vulcanizing tape, or equivalent.

Figure 11 Connectors on Bottom of Antenna Assembly

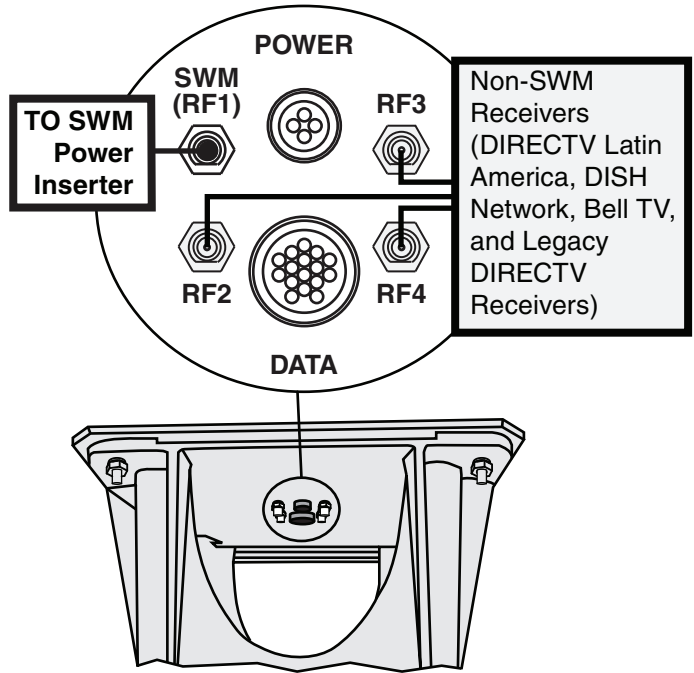

7

Continued Wire the Antenna

Connect Additional RF Cables - Non-SWM Receivers/DVRs Only

Follow the instructions below if you need to connect non-SWM receivers/DVRs. Non-SWM receivers/DVRs include DIRECTV Latin America, DISH Network, Bell TV, and legacy DIRECTV receivers. SWM-compatible receivers/DVRs are listed below.

- HR20
- HR21
- HR21 Pro
- HR22
- HR23
- H20
- H21
- H22
- H23
- R16
- R22
- R23
- D12
- D13

NOTE: Additional SWM-compatible receivers/DVRs might become available at any time. If your receiver or DVR model is not listed here, check the receiver's/DVR's manual to see if it is SWM-compatible.

- a. Connect RF cables to the antenna's RF2 and RF3 connectors (see Figure 12). Then, using a 7/16" open-end wrench, tighten the RF cables for 1/4 turn.
- b. Label the ends of the SWM (RF1), RF2, and RF3 cables for easy identification later.
- c. Seal the RF cable connections with silicone sealant, self-vulcanizing tape, or equivalent.
- d. Route the cables belowdecks through the cable access hole. Leave an adequate service loop, approximately 8" (20 cm) of slack, in the cables for easy serviceability.

Figure 12 Connectors on Bottom of Antenna Assembly

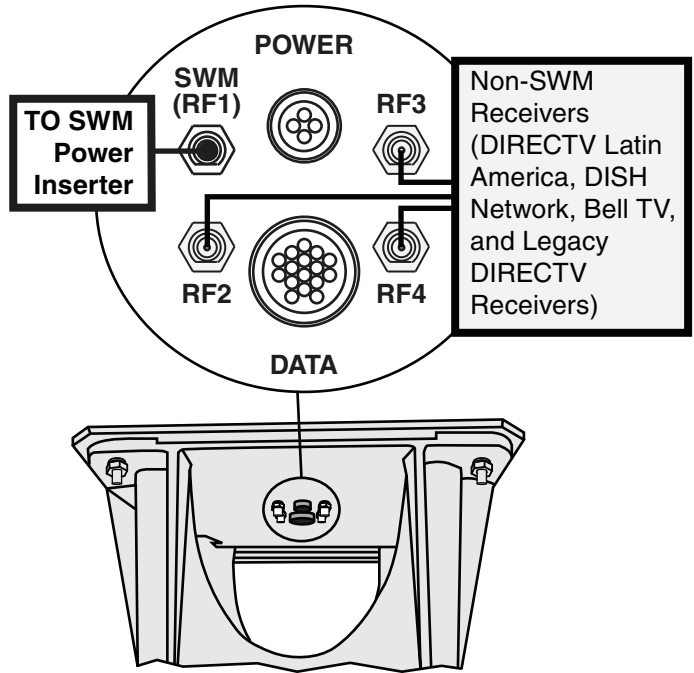

8 Mount the Antenna

Follow the steps below to mount the antenna to the mounting surface.

- a. Place the antenna baseplate over the holes drilled in the mounting surface.
- b. Ensure the forward arrow inside the baseplate points toward the bow and is parallel to the vessel's centerline (see Figure 13).

IMPORTANT!

You will need to rotate the antenna assembly by hand to see all four mounting holes. Rotate the antenna assembly slowly to avoid damaging the antenna.

- c. At each of the four baseplate mounting holes, place an M10 lock washer and flat washer on an M10 bolt and insert the bolt into the hole from below (see Figure 14).
- d. Tighten all four bolts until the four rubber feet on the baseplate are bottomed against the mounting surface and the foam seal is fully compressed. KVH recommends that you tighten the bolts to between 12 and 16 ft-lbs (16.2 and 21.7 N-m) of torque.

Figure 13 Forward Arrow Location

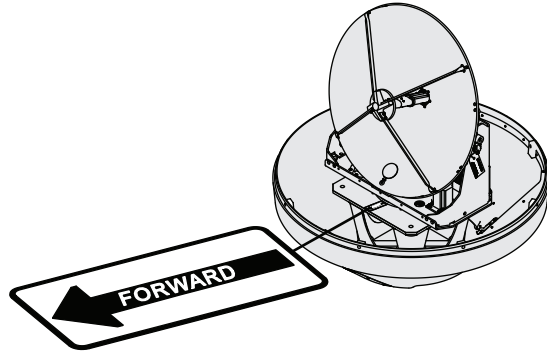
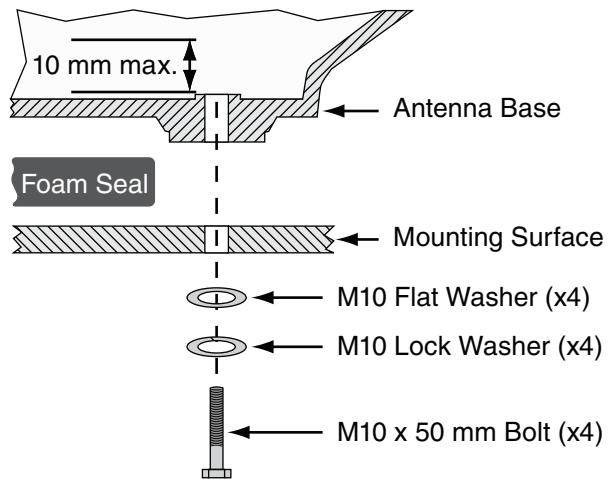

Figure 14 Antenna Mounting



9 Remove the Shipping Restraints

Remove the Shipping Restraint Brackets

Internal shipping restraint brackets prevent the antenna assembly from moving during shipment. Using a 9/16" nut driver or wrench, remove the two 3/8" bolts, washers, and lock nuts securing the two brackets (see Figure 15).

NOTE: Be sure to keep the brackets for future use.

Reinstall the Mounting Bolts

Follow the steps below to reinstall the bolts securing the antenna assembly to the internal mounting platform.

- Place a 3/8" flat washer (supplied in the kitpack) on the two 3/8" bolts that you just removed (see Figure 16).
- Reinstall the bolts and secure in place with the washers and lock nuts you removed earlier (see Figure 16).

Remove the Shipping Restraints

Using cutting pliers, cut and remove the tie-wrap and wire equipped with paper tags (see Figure 17).

Reinstall the Radome and Add Screw Caps

- Reinstall the radome and access hatch onto the antenna. Secure the radome and hatch in place using the screws you removed in "Remove the Hatch and Radome" on page 8.
- Install a plastic screw cap (supplied in the kitpack) over the eight radome screws.

Figure 15 Shipping Restraint Bracket Removal

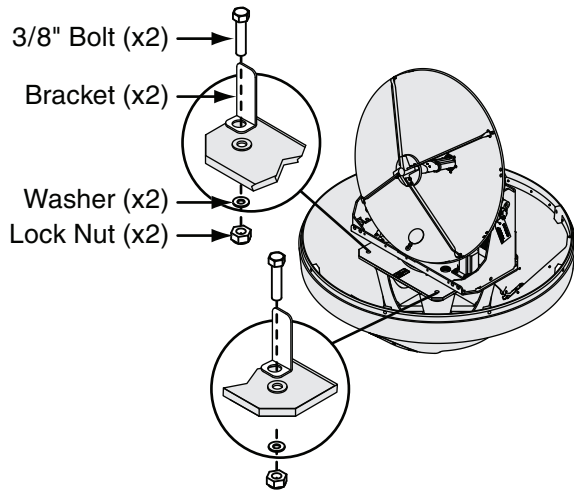

Figure 16 Mounting Bolt Reinstallation

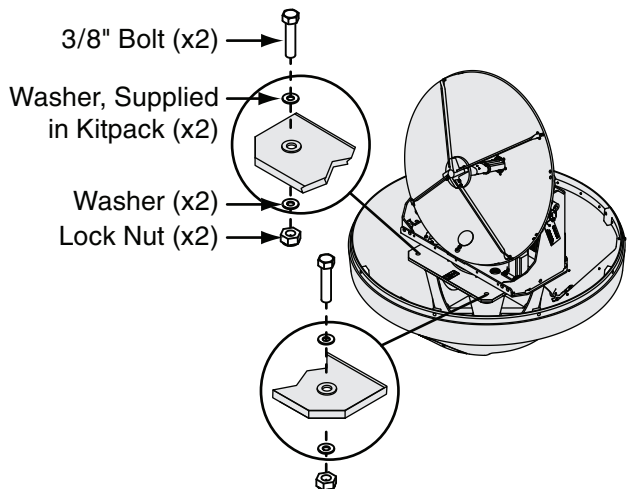
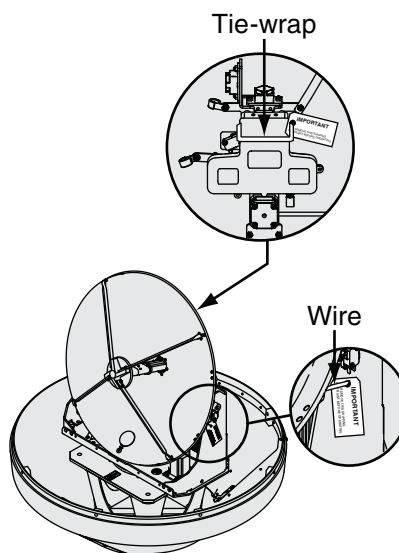

Figure 17 Shipping Restraints



10 Mount the ACU

Follow the steps below to mount the ACU to a standard 19" (482.6 mm) equipment rack or a horizontal surface.

Option A - Equipment Rack Mounting

- a. Align the four mounting holes on the front panel of the ACU to the mounting holes on the equipment rack (see [Figure 18](#)).
- b. Secure the ACU to the equipment rack using four M6 screws and washers (see [Figure 18](#)).

Figure 18 ACU Equipment Rack Mounting

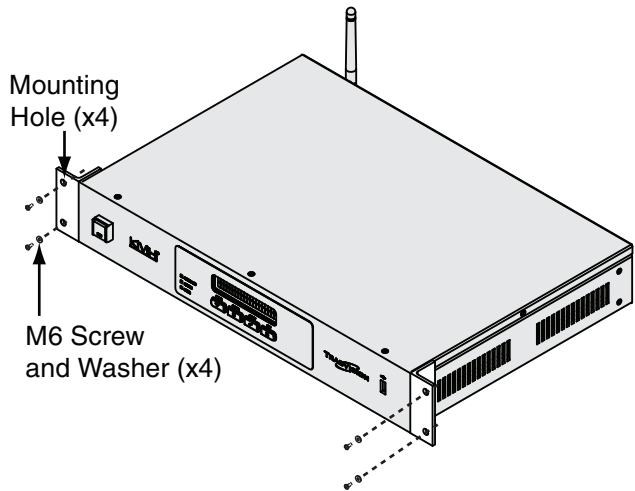

10 Continued Mount the ACU

Option B - Horizontal Mounting

- a. Using a #1 Phillips screwdriver, remove the six screws securing the rack mounting brackets to the sides of the ACU (see [Figure 19](#)).
- b. Using a #1 Phillips screwdriver, secure the mounting brackets to the sides of the ACU in the bracket orientation for your installation (see [Figure 20](#) or [Figure 21](#)). Then secure the mounting brackets using four supplied #6-32 Phillips screws and #6 washers.
- c. Using fasteners appropriate for the mounting surface, secure the ACU to the mounting surface using the four mounting bracket holes.

Figure 19 ACU Rack Mounting Bracket Removal

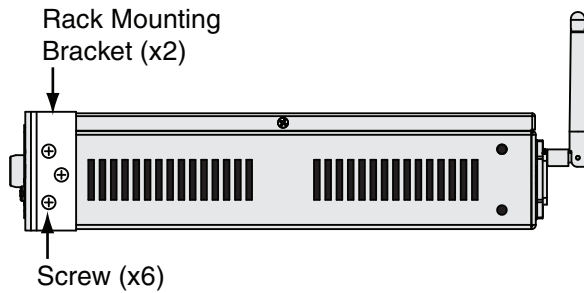

Figure 20 Horizontal Mounting Bracket Orientation

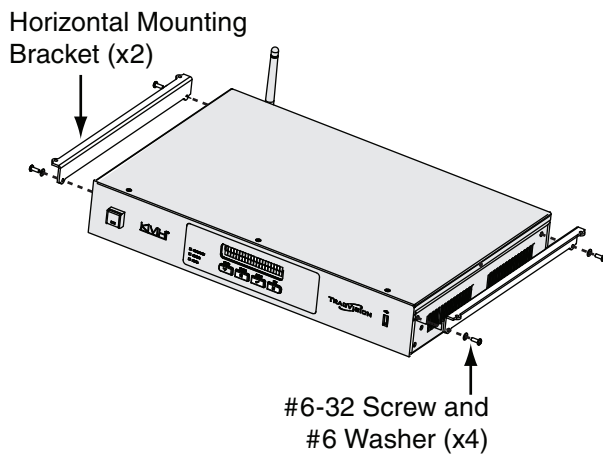
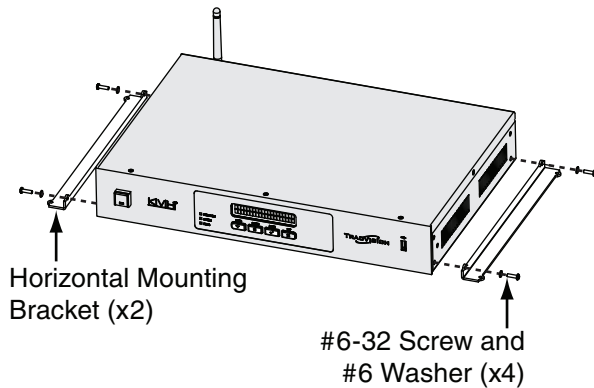

Figure 21 Horizontal Mounting Bracket Orientation



11 Wire the ACU

Follow the steps below to wire the ACU.

- Connect the antenna's data cable wires to the terminal strip connector (supplied in the kitpack), as shown in [Figure 22](#). Using a #0 flat-head screwdriver, tighten each terminal screw to secure the wires in place.
- Connect the antenna's power cable wires to the terminal strip connector, as shown in [Figure 22](#). Using a #0 flat-head screwdriver, tighten each terminal screw to secure the wires in place.
- Press and lock the terminal strip connector into place on the rear of the ACU (see [Figure 23](#)).
- Connect the ACU's 120 VAC power cord to the rear of the ACU (see [Figure 23](#)). Then plug the cord into a UPS or surge protector.
- Optional - If you plan to connect the ACU to an onboard network using the supplied Ethernet cable, connect it to the ACU's Ethernet port (see [Figure 24](#)).

Figure 22 Terminal Strip Connector

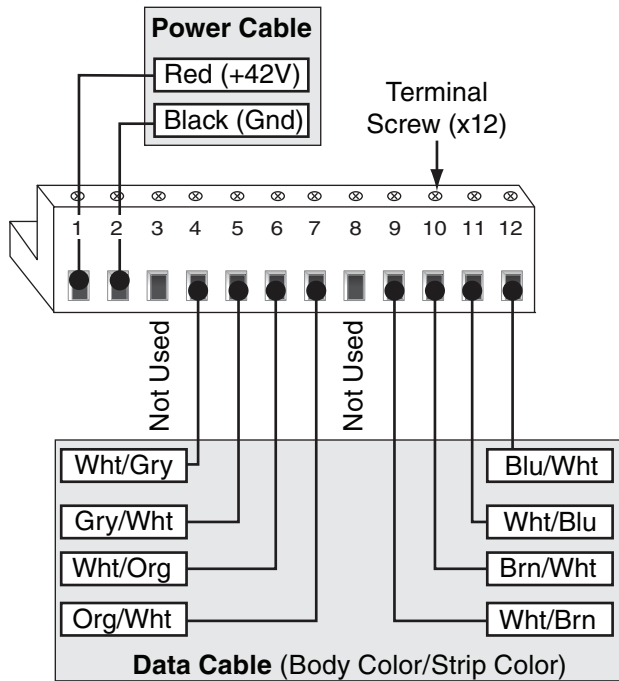

Figure 23 Terminal Strip/Power Supply

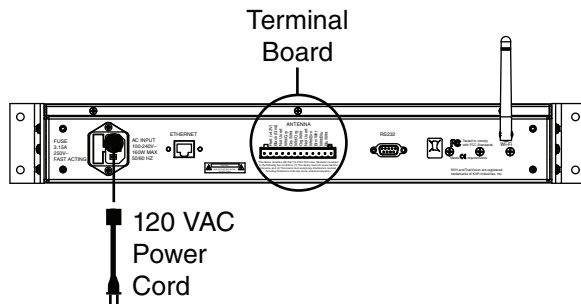
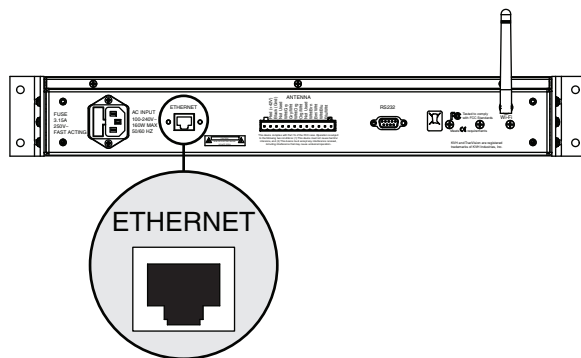

Figure 24 Ethernet Port



12 Wire Supplied Components

Follow the steps below to wire the power inserter, which is required for all installations, and the supplied 8-way splitter, which is only required for DIRECTV service.

NOTE: Only SWM-compatible splitters may be used.

Connect and Mount the Power Inserter

- Attach a Snap-N-Seal F-type connector to the SWM (RF1) cable from the antenna. Then connect the cable to the power inserter's SWM connector (see [Figure 25](#)).
- Using fasteners appropriate for the mounting surface, secure the power inserter to the mounting surface.

Connect and Mount the Splitter

IMPORTANT!

This section explains how to connect the 8-way splitter for DIRECTV SWM receivers/DVRs only. If you need to install non-SWM receivers/DVRs, refer to the wiring diagrams in "Wiring Non-SWM Receivers" on page 29.

- Using the screws supplied with the splitter, secure the splitter to an appropriate mounting surface.
- Fasten one end of the 25 ft (30 m) ground wire (supplied in the kitpack) to the splitter's grounding screw. Connect the other end of the ground wire to a suitable AC ground (see [Figure 26](#)).
- Connect one end of an RF cable to the power inserter's IRD connector. Connect the other end of the cable to the splitter's In connector (see [Figure 26](#)).

Figure 25 Power Inserter Connection

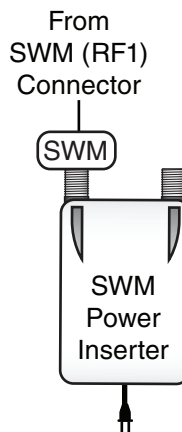
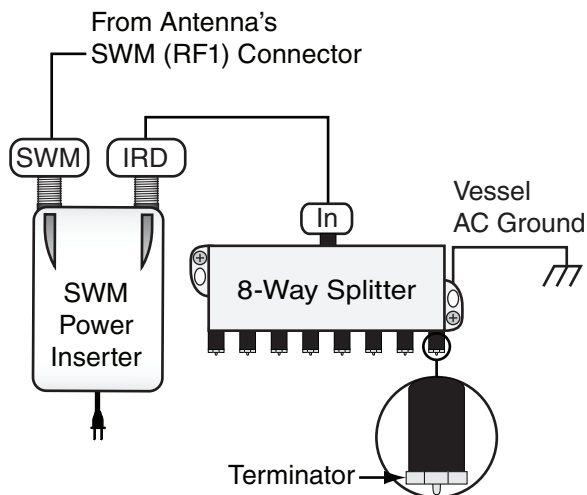

Figure 26 8-Way Splitter Connection (DIRECTV Only)



12 Continued Wire Supplied Components

Connect Receivers/DVRs to the Splitter

Now you need to connect the receivers and/or DVRs to the splitter. Consider the following connection guidelines before you begin:

- Refer to the basic wiring diagrams in [Figure 27](#) and [Figure 28](#).
- Since the 8-way splitter supports up to 8 tuners, you can connect any number of SWM receivers/DVRs that adds up to 8 tuners or fewer.
- Each receiver has a single tuner, and requires one RF cable. Each DVR has two tuners, and requires one RF cable.
- If you need to connect more than 8 SWM-compatible receivers or 4 DVRs (more than 8 tuners total) for DIRECTV HD service, install a 16-tuner SWM Expander Kit (KVH part #72-0452-01) or a 32-tuner SWM Expander Kit (KVH part #72-0452-02). If you wish to connect non-SWM receivers, refer to [“Wiring Non-SWM Receivers”](#) on page 29.
- Connector labeling might vary between receiver and DVR models. Refer to the User’s Guide for your selected receivers/DVRs for complete information.
- Always terminate any unused splitter connectors with a supplied terminator (see [Figure 26](#) on page 16).

Figure 27 Basic SWM Receiver Wiring Diagram

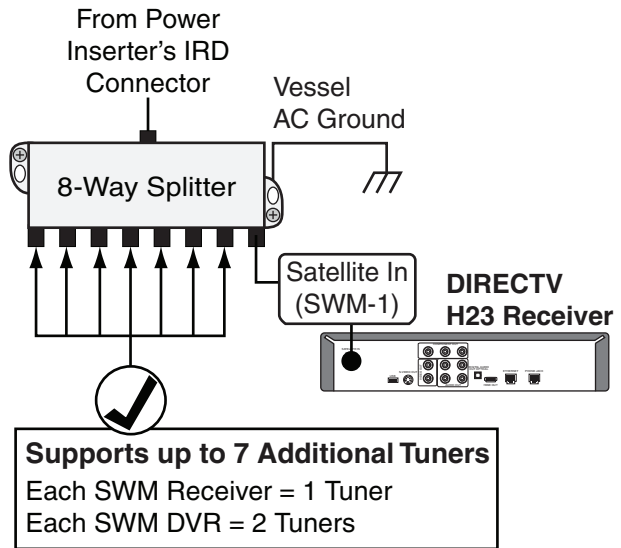
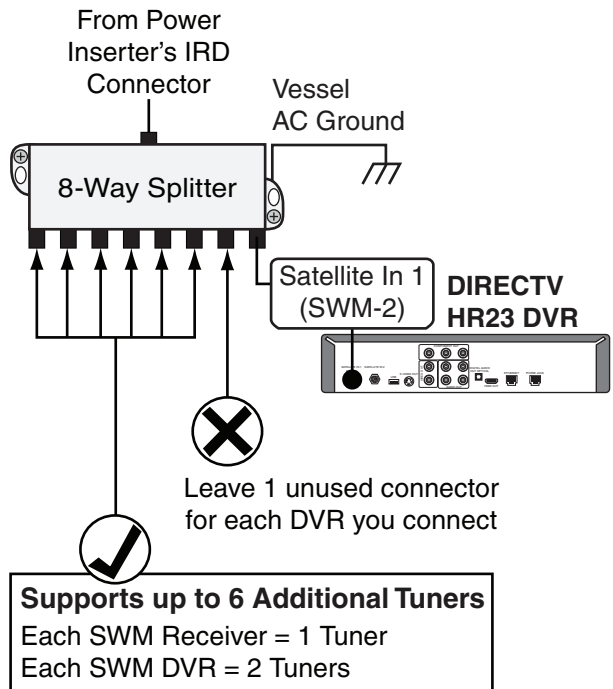

Figure 28 Basic SWM DVR Wiring Diagram



13 Configure Each Receiver/DVR

Follow the steps below to start up the TracVision system and configure each connected DIRECTV receiver/DVR for TracVision use.

IMPORTANT!

If you need to configure DIRECTV Latin America, DISH Network, Bell TV, or legacy DIRECTV receivers, refer to “Configuring Non-SWM Receivers” on page 33.

Power On the TracVision System

- Plug in and apply power to the power inserter.
- Press the power button on the front of the ACU to turn on the TracVision system (see Figure 29).
- Wait up to 3 minutes for the Tracking screen to display on the ACU (see Figure 30). This indicates system startup is complete.

Power On Connected Components

Plug in and turn on any connected receivers, DVRs, and televisions.

Set Each DIRECTV Receiver/DVR to Dish Type: Slimline-3

- Press the Menu button on the receiver’s/DVR’s remote control to display its menu on the connected television.

NOTE: Refer to your selected receiver/DVR manual for specific configuration instructions.

- At the “Satellite Dish Setup” menu, set the Dish Type to **Slimline-3**. Then choose **Continue** (see Figure 31).
- Repeat this procedure for each connected receiver/DVR.

Figure 29 ACU Power Button

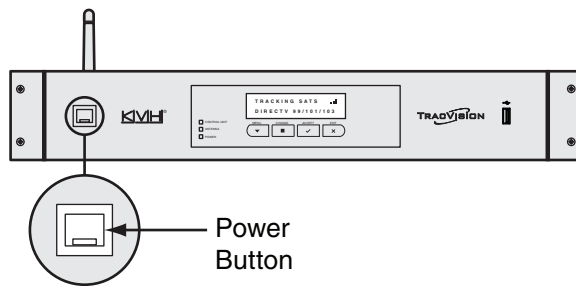
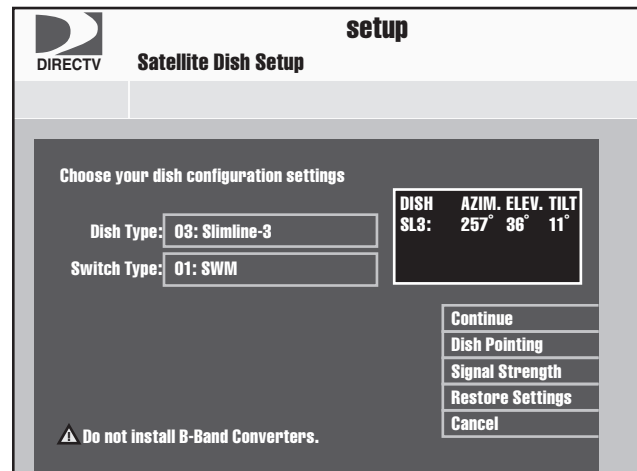

Figure 30 Tracking Screen



Figure 31 SWM Receiver/DVR Configuration



14

Connect the ACU to the Network

- Optional

This section details the ACU's default network settings, other available options, and methods for changing settings. When the TracVision system is connected to the vessel's onboard network, or you connect to the TracVision HD7 system using an ad-hoc WiFi connection, the following features are enabled:

- Remote operation of the TracVision HD7 system
- Remote viewing of the system's status, including current satellite signal levels, satellite settings, and other system information

NOTE: When setting up a wireless network, be sure to apply security settings, such as encryption, to protect your network from outside intrusion. If your network is not secure, outsiders within range of your wireless network will be able to use your wireless connection without your knowledge.

TIP: The ACU is Bonjour[®]-enabled. Once the ACU is connected to the vessel's onboard network, you can use Bonjour to easily connect to the ACU using a PC on the same network, without requiring the IP address. The ACU is displayed in Bonjour as: **hd7-<ACU serial number>**. For more information, visit www.apple.com/support/bonjour.

Figure 32 Connection Options

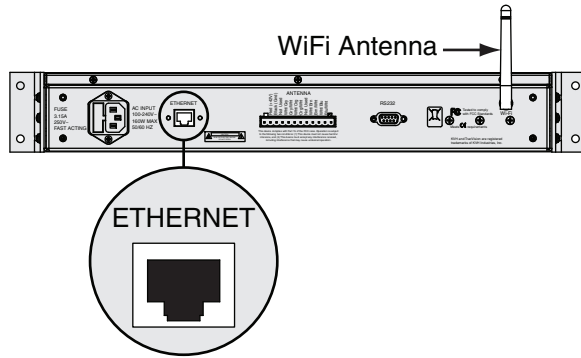

14 Continued Connect the ACU to the Network

Network Connection Options

Choose one of the options below to enable a network connection.

NOTE: You can find the IP address assigned to the ACU in the View Wi-Fi Settings and View Enet Settings menus (see Figure 33).

- Connect to the vessel's onboard network using the ACU's Ethernet port
- Connect to the vessel's onboard network using the ACU's built-in WiFi antenna

Default Ethernet Settings

The ACU's Ethernet port is set up as a DHCP client; the vessel's router can automatically assign an IP address when connected to the ACU's Ethernet port. In this case, you will need to connect your PC to the network, or use an existing PC connected to the network, to access the ACU's web interface.

If there is no Ethernet network onboard the vessel, and/or no DHCP server is on the network, the ACU will assign itself an IP address that begins with 169.254 (i.e. 169.254.x.x). In this case, you can connect your PC directly to the ACU's Ethernet port. If your PC is configured for automatic IP assignment by default, it should also assign a similar IP address on the same IP network.

Default WiFi Settings

The ACU's WiFi adapter is configured for an ad-hoc connection, with security disabled. This allows you to connect a PC directly to the ACU via its wireless antenna.

If you wish to connect the ACU to the vessel's onboard network using the WiFi connection, set the ACU's WiFi State to "Infrastructure" at the ACU's System Settings>Wi-Fi Settings menu.

Figure 33 Viewing Network Settings on the ACU

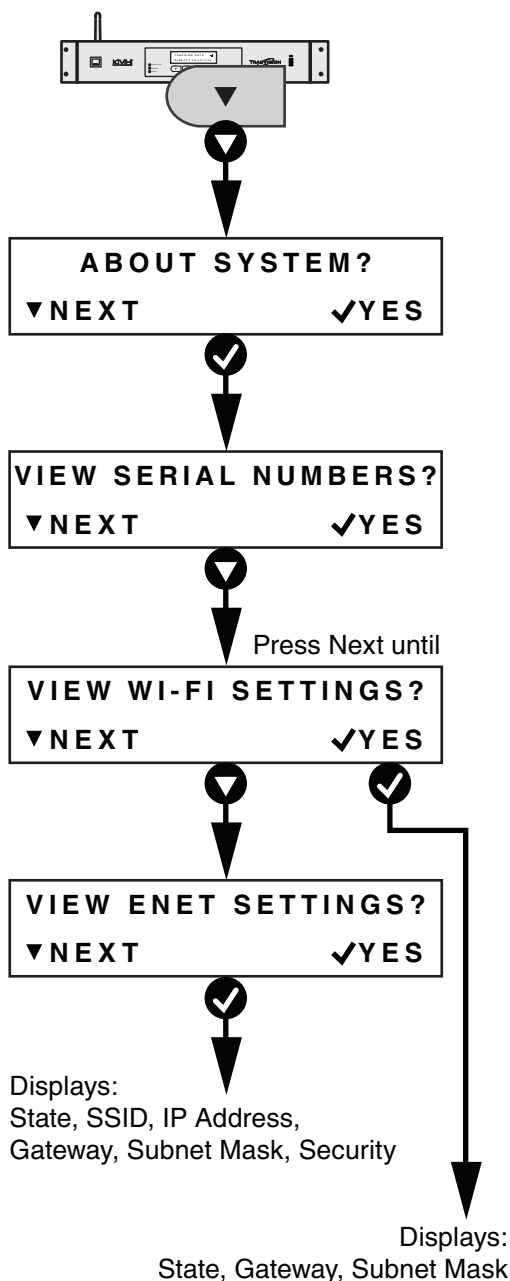

14 Continued Connect the ACU to the Network

Changing Network Settings

Choose one of the methods below if you need to change network settings (such as the IP address or subnet mask):

- Option A - Use the Web Interface (Recommended)
- Option B - Use the ACU Buttons

Option A - Use the Web Interface (Recommended)

Follow the instructions below to use the web browser on your PC to change network settings.

- Using a PC connected to the vessel's network, open the web browser.
- Enter the ACU's IP address into the web browser's address bar (Figure 34).
- Log in to the web interface using the username and password below (see Figure 35).

username: **admin**
password: **password**

- Select the Settings tab. Then choose Edit to modify the desired network settings (see Figure 36).

Figure 34 Entering the IP Address (Example)

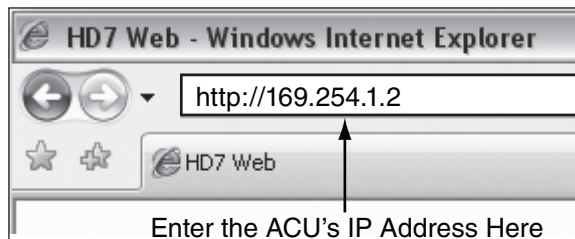

Figure 35 Web Interface Login Screen

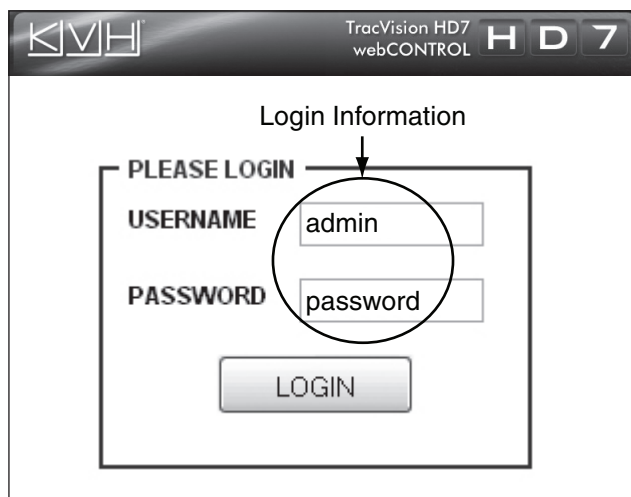
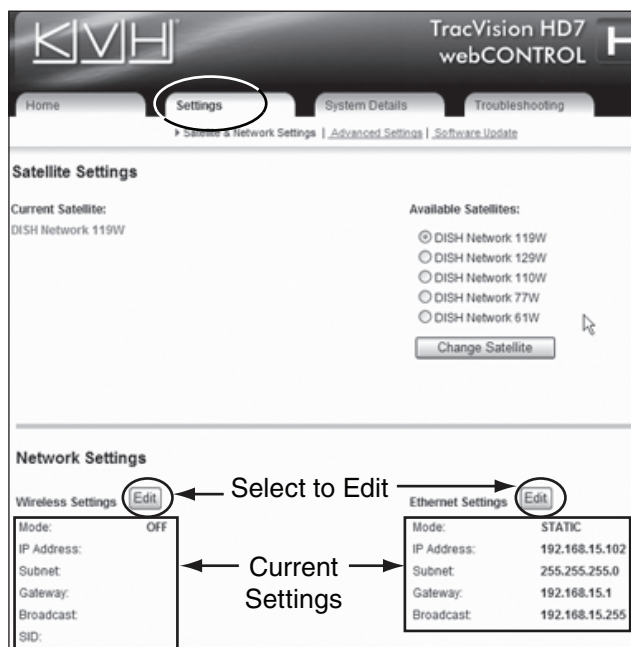

Figure 36 Network Settings on the Web Interface



14 Continued Connect the ACU to the Network

Option B - Use the ACU Buttons

Use the flowchart in [Figure 37](#) to access the Wi-Fi Settings or Ethernet Settings menu and change the desired network settings.

Figure 37 Network Settings Menus

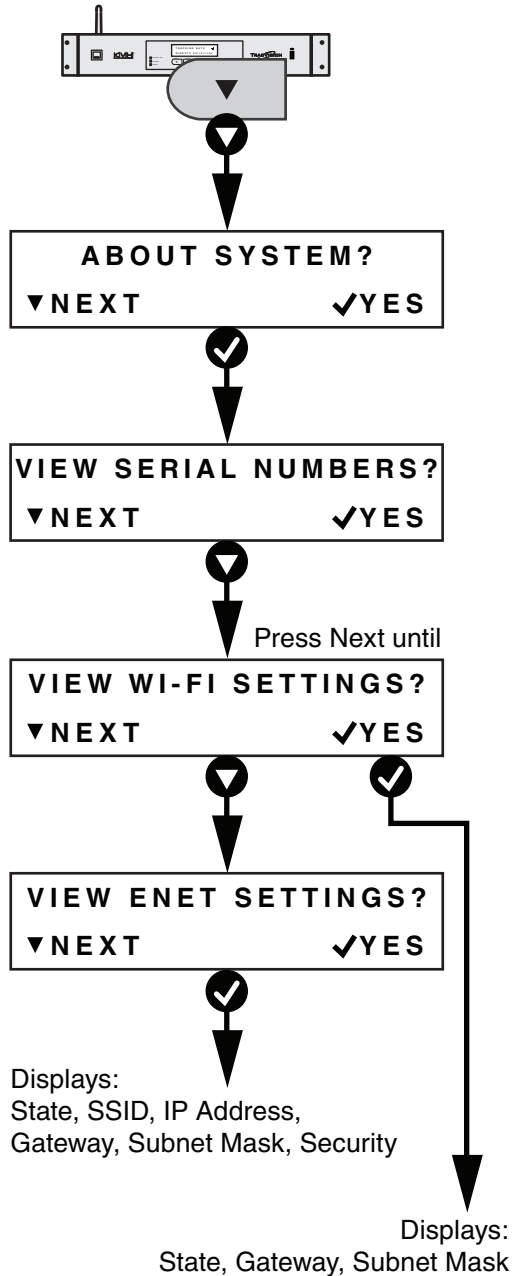

15 Update the Software if Necessary

Choose one of the following options to check for and install software updates.

NOTE: Checking for updates requires Internet access. Be sure to restart the TracVision system before installing updates.

TIP: You can view the ACU's current IP address and other Ethernet settings at any time using the ACU buttons (see [Figure 33](#) on page 20).

Option A - Use the Web Interface

- Enter the ACU's IP address into the address bar of your web browser (see [Figure 34](#) on page 21).
- Log in to the web interface using the username and password below.

username: **admin**
password: **password**

- Select Check for Updates (see [Figure 38](#)). Then follow the onscreen instructions to check for and install available software updates.

Option B - Use a USB Flash Drive

If you already have new software saved on a USB flash drive, just plug the flash drive into the USB port and follow the ACU's onscreen instructions to update the software (see [Figure 39](#)).

Option C - Use the TracVision iPhone® App

If you have the KVH TracVision iPhone/iPod touch application loaded and configured for use with the network, follow the app's onscreen instructions to check for and install new software.

You can download the TracVision iPhone app for free from the Apple iTunes® app store.

Figure 38 Check for Updates on Web Interface

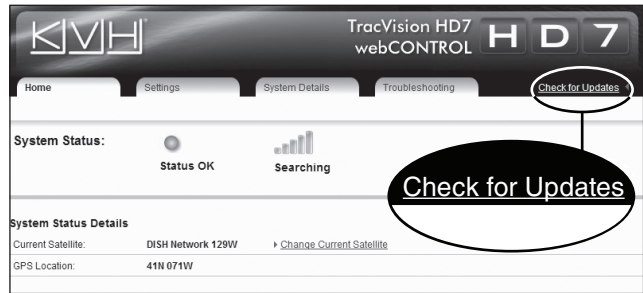
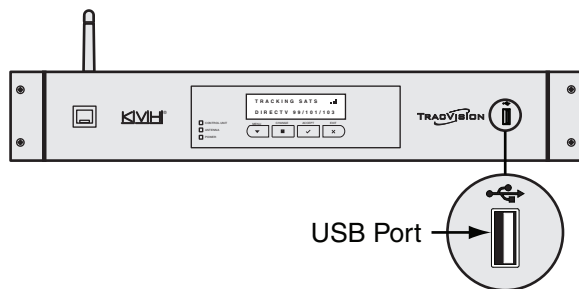

Figure 39 USB Port on ACU



NOTE: The software update (.kvh) file must be located in the USB flash drive's root directory. Be sure to keep only one update file on the flash drive.

16 Educate the Customer

Before you leave the vessel, test the system to ensure the antenna works properly. Then give the Customer Welcome Kit to the customer and explain how to use the system. Ensure the customer understands the following:

- Keep the radome installed on the antenna at all times.
- The antenna must have a clear view of the sky to receive satellite TV. Common causes of blockage include bridges and boat masts.
- Heavy rain or snow might temporarily interrupt reception.
- Clean the radome regularly. Dirt buildup can affect reception.
- The vessel must be located within the satellites' coverage area to receive satellite TV signals. To view satellite coverage information, visit www.kvh.com/footprint.
- Please register the system with KVH. The registration process is quick, easy, online, and ensures the best possible service from KVH. Visit www.kvh.com/register or refer to the Product Registration Form for details.
- You need to activate any connected receivers/DVRs for the desired satellite TV service before you can watch television. KVH can help activate a DIRECTV or DISH Network receiver/DVR; just call KVH's Activation Department at 1-866-551-8004 for DIRECTV or 1-866-399-8509 for DISH Network.
- Refer to the supplied TracVision HD7 User's Guide for operation instructions and troubleshooting information.
- You can use the KVH TracVision iPhone/iPod touch app to communicate with the TracVision system, as long as it is connected to the vessel's onboard network. You can download the app for free at the Apple iTunes store.

Figure 40 Example of Blockage

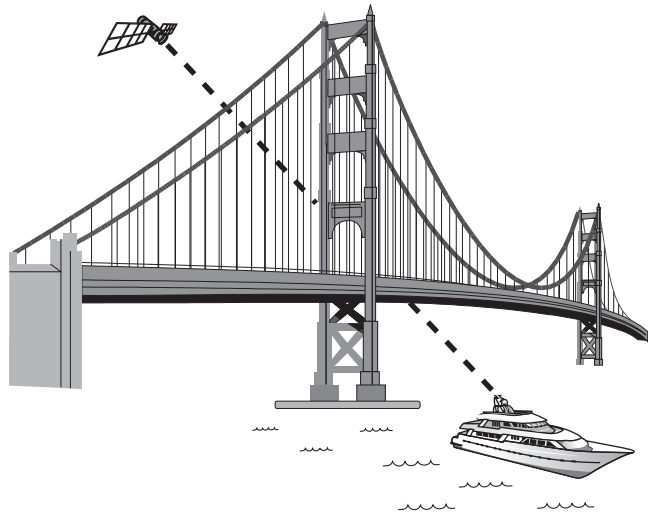
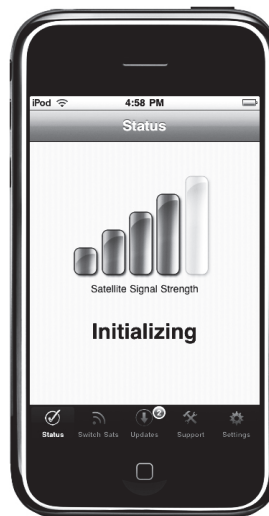

Figure 41 KVH TracVision iPhone/iPod touch App



Appendices

This section provides additional information on receiver compatibility, receiver setup, and custom wiring instructions.

Contents

| | |
|--|----|
| A. Using an Ad-Hoc Connection..... | 27 |
| B. Wiring Non-SWM Receivers..... | 29 |
| C. Configuring Non-SWM Receivers | 33 |
| D. ACU Menu Structure | 35 |

A Using an Ad-Hoc Connection

If the ACU is not connected to an onboard network and you wish to connect your PC to the ACU using an ad-hoc WiFi connection, follow the instructions below to view or modify ad-hoc settings.

NOTE: The ACU is Bonjour[®]-enabled. Once the ACU is connected to the vessel's onboard network, you can use Bonjour to easily connect to the ACU using a PC on the same network, without requiring the IP address. The ACU is displayed in Bonjour as: *hd7-<ACU serial number>*. For more information, visit www.apple.com/support/bonjour.

Viewing Settings

Follow the steps below to view the current WiFi settings.

- a. Use the flowchart in [Figure 42](#) to access the View Wi-Fi Settings menu. Then press "Next" to scroll through the current settings.

NOTE: The WiFi state must be set to "Ad-hoc" to enable an ad-hoc connection (see [Figure 43](#)). If you need to change this setting or other WiFi settings, skip to "[Modifying Settings](#)" on page 28.

- b. If you plan to connect using an ad-hoc connection later, record the following WiFi settings:
 - SSID
 - IP address
 - Password (if WEP is enabled)

Figure 42 View WiFi Settings

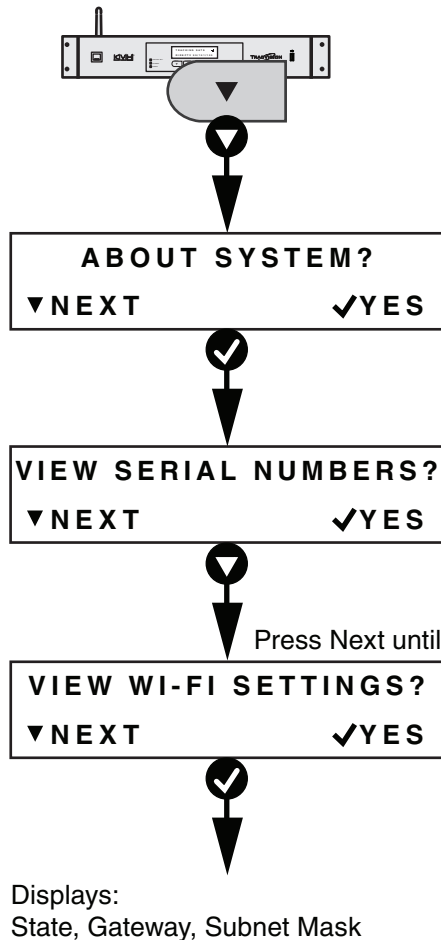

Figure 43 Ad-Hoc WiFi State



A

Continued Using an Ad-Hoc Connection

Modifying Settings

Follow the instructions below to use the web browser on your PC to modify network settings.

NOTE: When setting up a wireless network, be sure to apply security settings, such as encryption, to protect your network from outside intrusion. If your network is not secure, outsiders within range of your wireless network will be able to use your wireless connection without your knowledge.

- a. Using your PC, establish an ad-hoc connection to the ACU.

TIP: Refer to “Viewing Settings” on page 27 for connection information.

- b. Enter the ACU’s IP address into the web browser’s address bar (Figure 44).
- c. Log in to the web interface using the username and password below (see Figure 45).

username: **admin**
password: **password**

- d. Select the Settings tab. Then choose Edit to modify the desired network settings (see Figure 46)

Figure 44 Entering the IP Address (Example)

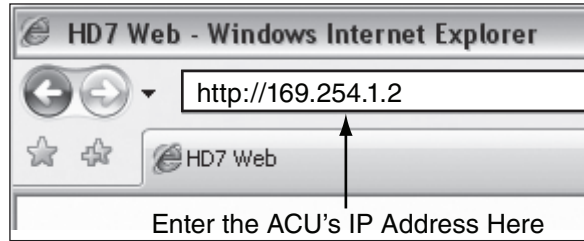

Figure 45 Web Interface Login Screen

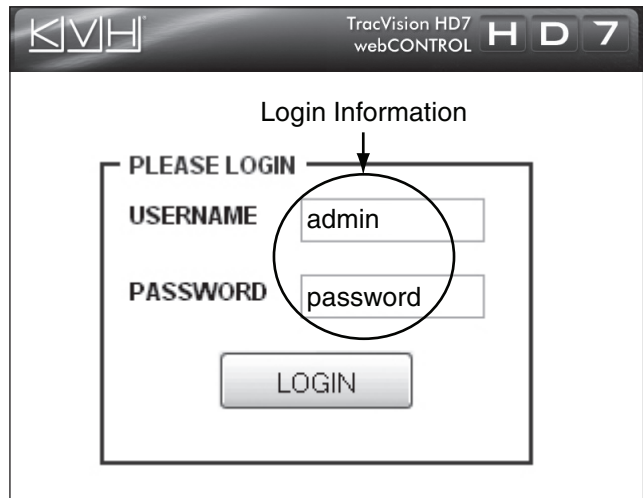
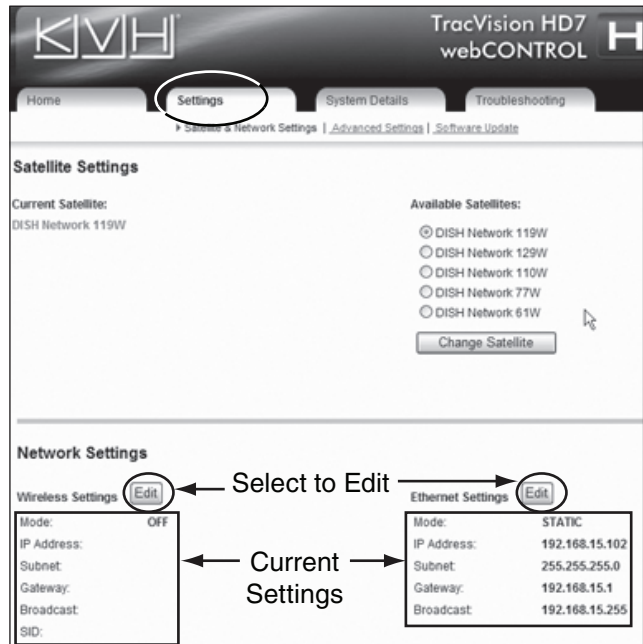

Figure 46 Network Settings on the Web Interface



B Wiring Non-SWM Receivers

.The following wiring diagrams illustrate how to connect non-SWM receivers/DVRs to the TracVision HD7 system. Non-SWM receivers/DVRs include DIRECTV Latin America, DISH Network, Bell TV, and legacy DIRECTV receivers. SWM-compatible receivers/DVRs are listed below.

- HR20
- HR21
- HR21 Pro
- HR22
- HR23
- H20
- H21
- H22
- H23
- R16
- R22
- R23
- D12
- D13

NOTE: Additional SWM-compatible receivers/DVRs might become available at any time. If your receiver or DVR model is not listed here, check the receiver's/DVR's manual to see if it is SWM-compatible.

B Continued Wiring Non-SWM Receivers

Wiring Up to 4 Non-SWM Receivers

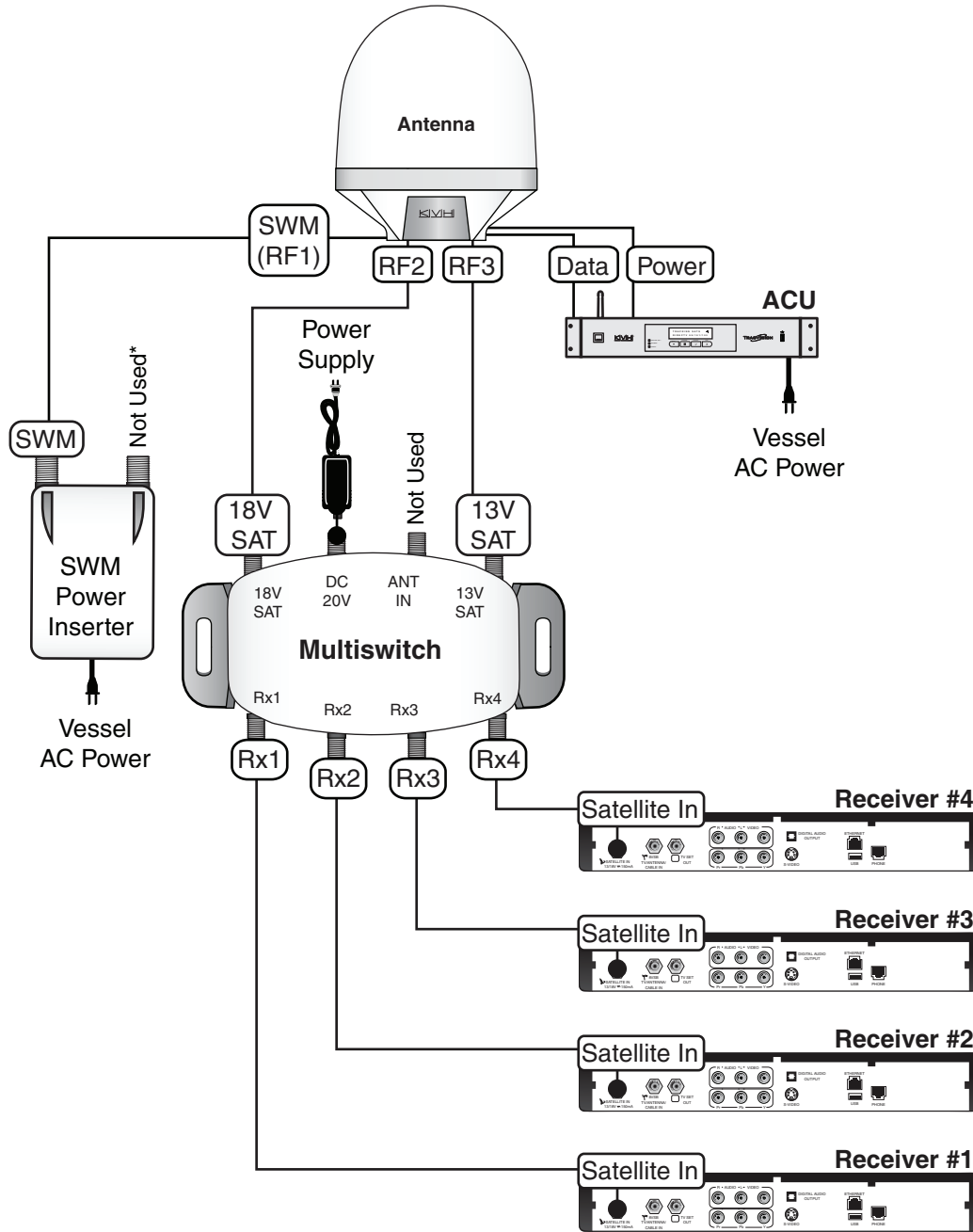

*The supplied SWM power inserter, shown above, is required, since it supplies power to the antenna's LNB. However, this power inserter connector is not used in this configuration; it is reserved for a SWM splitter connection only.

B Continued Wiring Non-SWM Receivers

Wiring Up to 8 Non-SWM Receivers

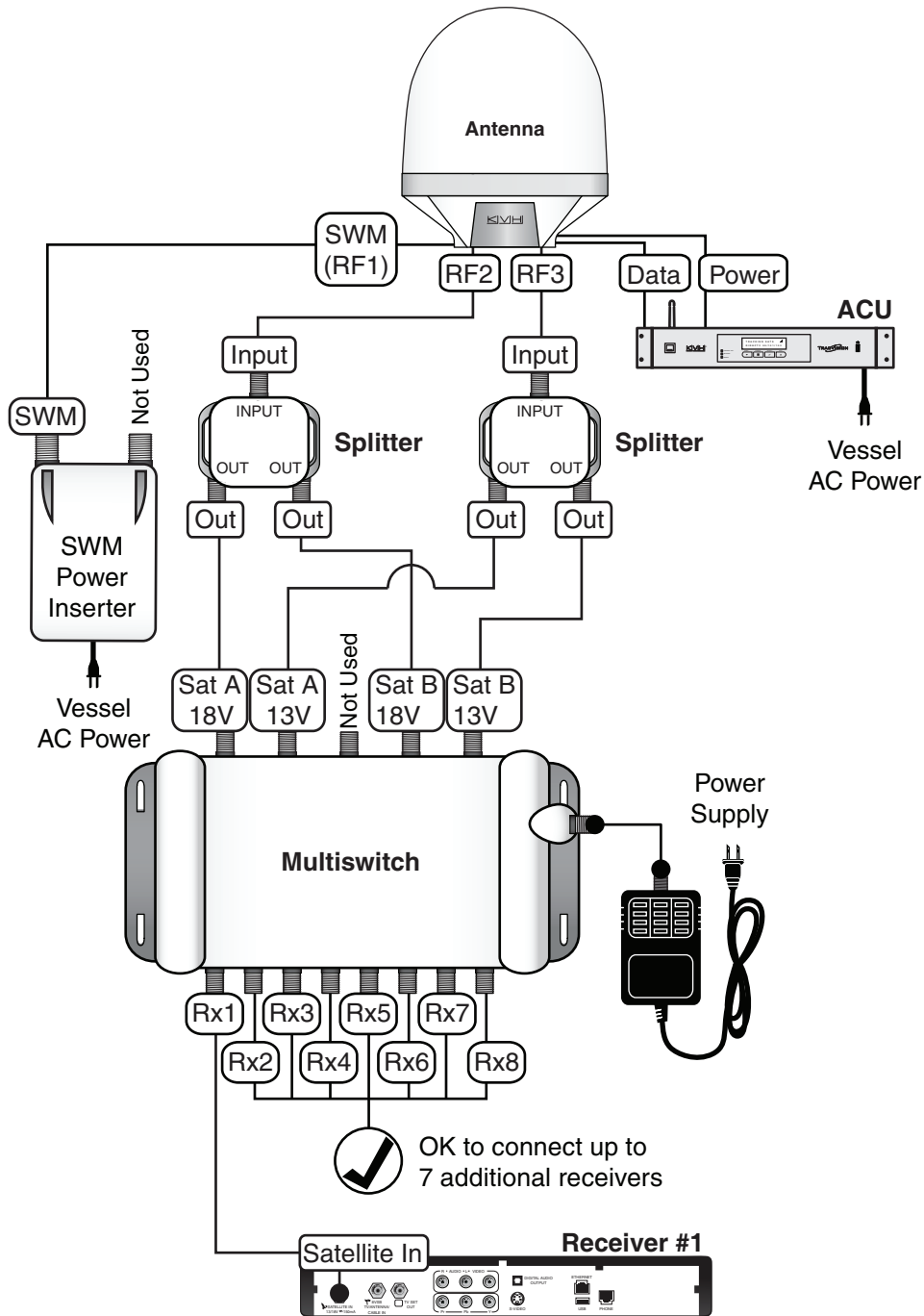

*The supplied SWM power inserter, shown above, is required, since it supplies power to the antenna's LNB. However, this power inserter connector is not used in this configuration; it is reserved for a SWM splitter connection only.

NOTE: If desired, you can connect up to 16 receivers using this wiring diagram and a 16-output multiswitch.

B Continued Wiring Non-SWM Receivers

Wiring SWM and Non-SWM Receivers

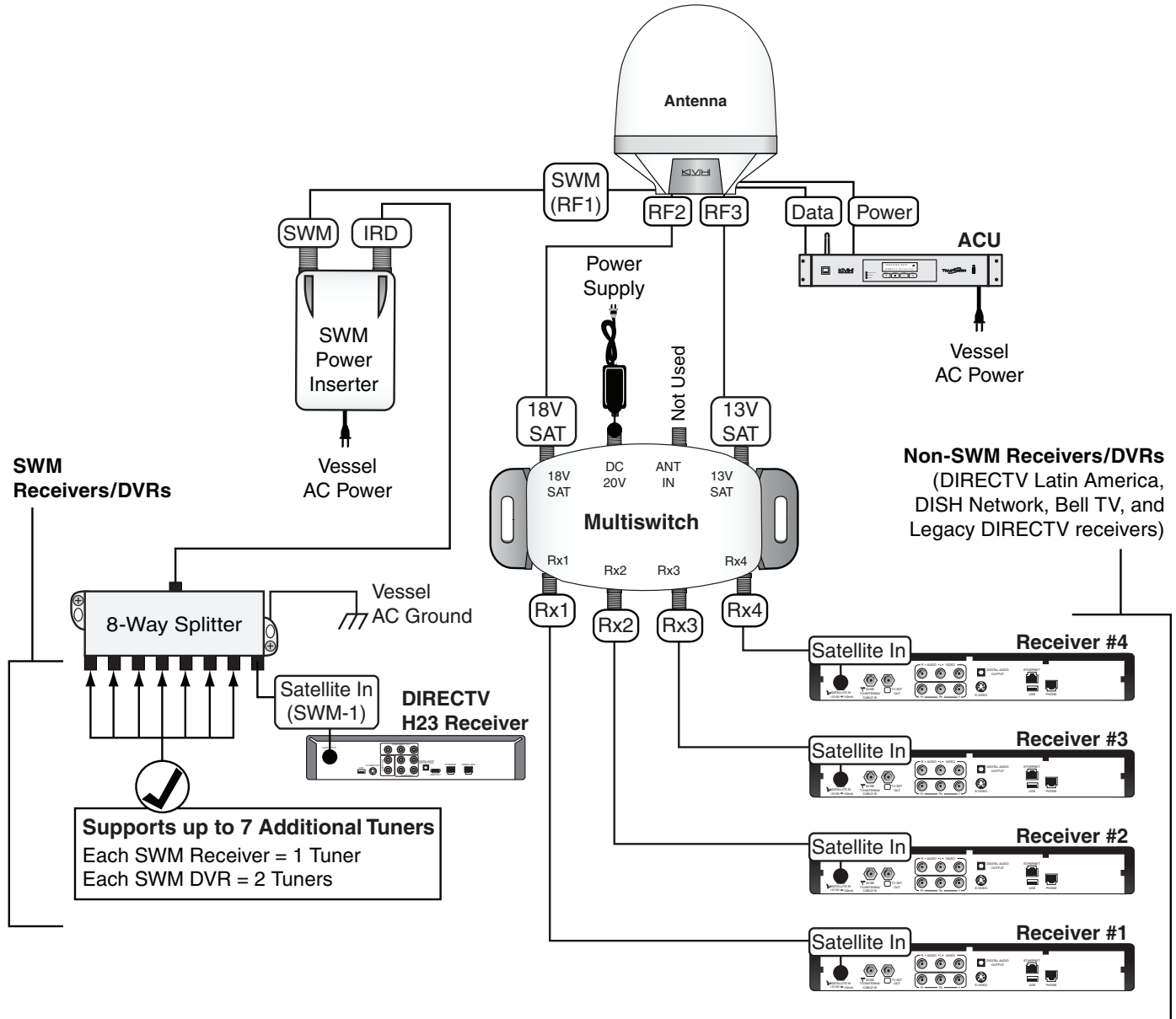

Configuring Non-SWM Receivers

Follow the steps below to set up the TracVision HD7 system to use your selected satellite service, and/or configure the non-SWM receivers for use with the TracVision HD7 system.

Step 1 - Set the Desired Satellite Service

Follow these steps to set up the TracVision HD7 system for the satellite service provider of your choice.

Option A - Use the Web Interface (Recommended)

Follow the instructions below to use the web browser on your PC to select the desired satellite service provider.

- Open your web browser. Ensure the PC is connected to the ACU's network.
- Enter the ACU's IP address into the web browser's address bar. Then press Enter (see [Figure 47](#)).
- Log in to the web interface using the username and password below (see [Figure 48](#)).

username: **admin**
password: **password**

- Select the Settings tab. Then choose Advanced Settings (see [Figure 49](#)).
- Select the desired satellite service provider. Then choose Change Service (see [Figure 49](#)).

Figure 47 Entering the IP Address (Example)

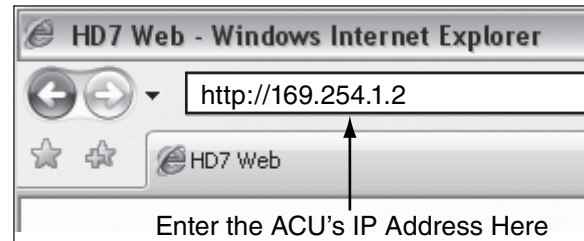

Figure 48 Web Interface Login Screen

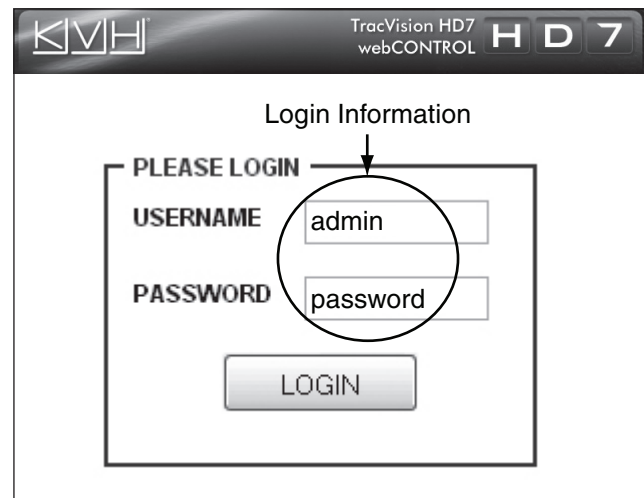

Figure 49 Advanced Settings





Continued Configuring Non-SWM Receivers

Option B - Use the ACU Buttons

Use the flowchart in [Figure 50](#) to access the Change Sat Service menu on the ACU. Then select the desired satellite service provider.

Step 2 - Set Up the Receivers

Follow the steps below to configure the non-SWM receivers.

DISH Network/Bell TV Receivers

Follow the steps below to run one Check Switch test on each connected receiver.

NOTE: Once the receivers are set up, you can switch satellites as needed using the ACU buttons, web interface, or TracVision iPhone/iPod touch app.

- Ensure the antenna has an unobstructed view of the sky.
- Using the receiver's remote control (and a connected television), go to the "Point Dish/Signal Strength" screen (press MENU, 6, 1, 1 on most receiver models).
- Choose Check Switch, then press SELECT.
- Choose Test (DISH Network) or Check (Bell TV), then press SELECT.
- Wait up to 10 minutes for the test to complete and the receiver's Program Guide to load.

TIP: Once complete, the Check Switch displays the current satellite, followed by "OK."

- Using the receiver's remote, select the Program Guide to ensure it has loaded properly.

DIRECTV Latin America/Legacy DIRECTV Receivers

Using the receiver's remote control (and a connected television), set the "Satellite DISH Type" to "Round." If you are configuring a legacy DIRECTV receiver, be sure to also choose "Multiswitch."

Figure 50 Changing Sat Service Menu

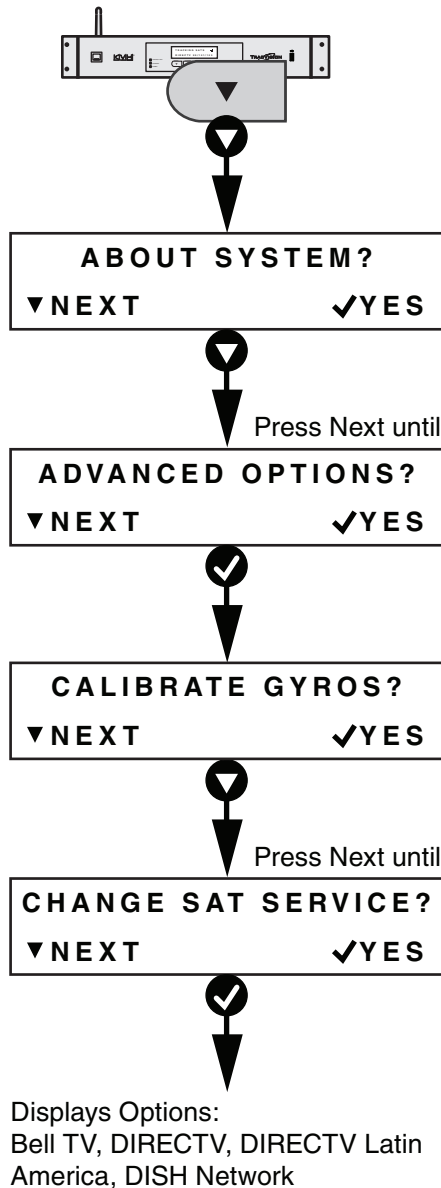

D ACU Menu Structure

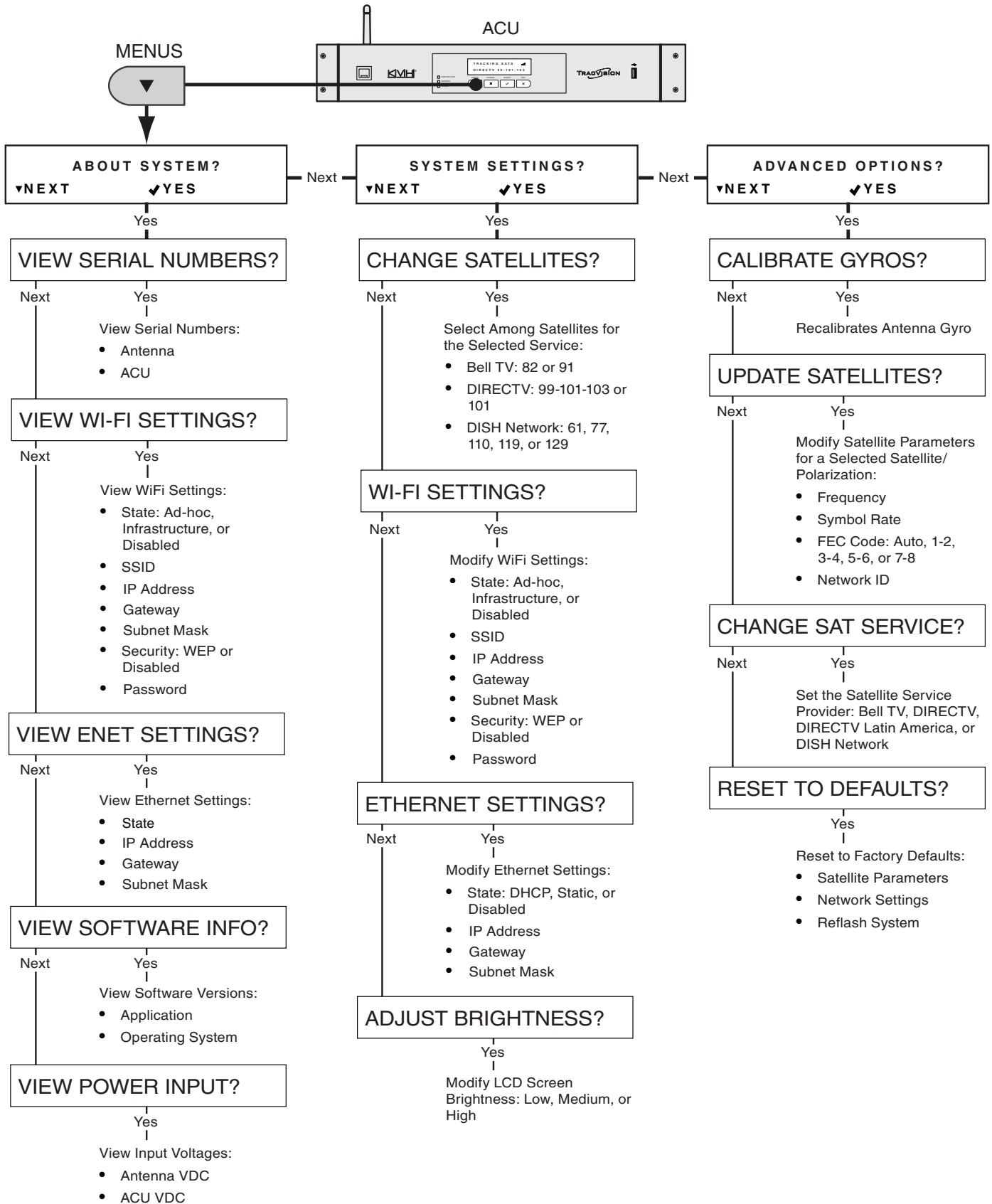



KVH Industries, Inc.

50 Enterprise Center Middletown, RI 02842-5279 U.S.A.
Phone: +1 401 847-3327 Fax: +1 401 849-0045
E-mail: info@kvh.com Internet: www.kvh.com

KVH Europe A/S

Kokkedal Industripark 2B 2980 Kokkedal Denmark
Phone: +45 45 160 180 Fax: +45 45 160 181
E-mail: info@kvh.dk Internet: www.kvh.com