

Tri-Americas™ LNB Installation

TracVision M5 Configuration

These instructions explain how to install the Tri-Americas LNB in your TracVision® system. With the Tri-Americas LNB, you no longer need to climb up to the antenna and change the LNB when you travel between North America, the Caribbean, Central America, and South America.



Depending on the LNB currently installed in the antenna, you might need to bypass the inverter PCB. Follow the guidelines below.

Steps Required

Currently Installed LNB:	Perform Steps:
<ul style="list-style-type: none"> Conventional Circular Galaxy 	<ol style="list-style-type: none"> Initial Steps (page 3) Bypass the Inverter PCB (page 4) Install the Tri-Americas LNB (page 6) Install the Tone Generators (page 9)
<ul style="list-style-type: none"> Compact Circular Linear Dual-output Linear Quad-output 	<ol style="list-style-type: none"> Initial Steps (page 3) Install the Tri-Americas LNB (page 6) Install the Tone Generators (page 9)

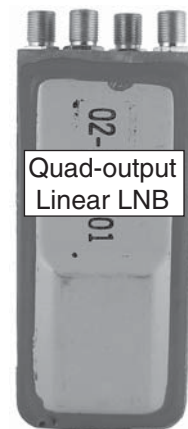
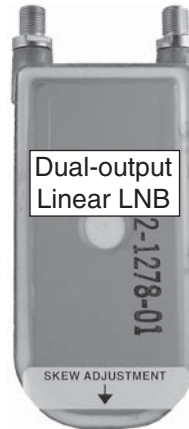
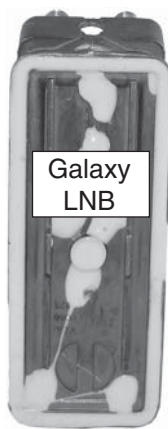

Technical Support

Phone: +1 401 847-3327
 E-mail: techs@kvh.com
 (Mon.-Fri., 9 am-6 pm ET, -5 GMT)
 (Sat., 9 am-2 pm ET, -5 GMT)

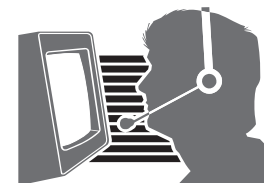

Initial Steps

Follow these steps to begin the LNB installation.

IMPORTANT!

If your TracVision antenna has a serial number earlier than **090500206**, you should have received a PCB upgrade kit in addition to this Tri-Americas LNB kit. Follow the instructions in the PCB upgrade kit first, before installing the Tri-Americas LNB. If you did not receive a PCB upgrade kit, please contact the KVH Sales Team at 401-847-3327.

- a. Gather all of the tools listed below. You will need these tools to complete the process.
- #2 Phillips screwdriver
 - 2 mm allen hex key
 - Wire cutters
 - 7/16" open-end wrench



CAUTION

For your own safety, disconnect power from all system components before you start working on the antenna.

- b. Disconnect power from all system components, including the receiver(s).
- c. Using a #2 Phillips screwdriver, remove the three #10-24 screws securing the radome to the antenna's baseplate (see Figure 1). Remove the radome and set it aside in a safe place.

IMPORTANT!

Avoid causing sharp bends in cables when securing or routing cables. Sharp bends or kinks can degrade antenna performance.

IMPORTANT!

Trim the excess portion of any tie-wraps you install and collect all tie-wrap trimmings to avoid damage when the antenna rotates.

Figure 1: Removing the Radome

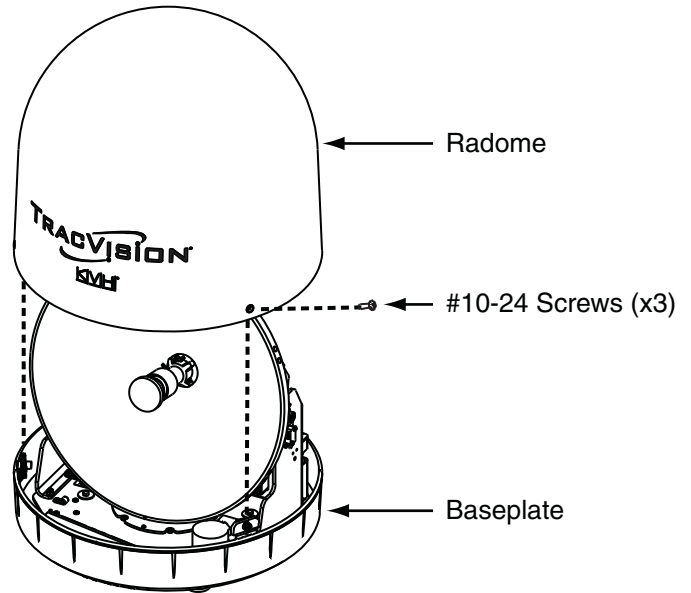

Bypassing the Inverter PCB

If your TracVision system is currently equipped with a **Galaxy** or **conventional circular LNB**, you must first bypass the inverter PCB (see Figure 2).

The following instructions explain how to bypass the inverter PCB.

- a. Using a 7/16" open-end wrench, disconnect and remove the RF cable connecting the inverter PCB to the RF PCB (see Figure 3).
- b. Disconnect the RF cable from the inverter PCB's "RF1 TO LNB" connector and connect it to the RF PCB's "TO LNB" connector (see Figure 4).

Figure 2: Location of Inverter PCB

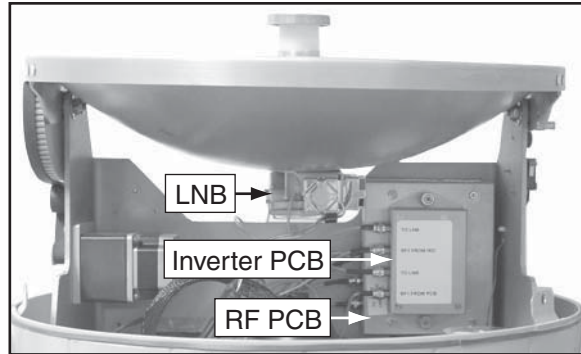

Figure 3: Cable Connecting the Inverter PCB to the RF PCB

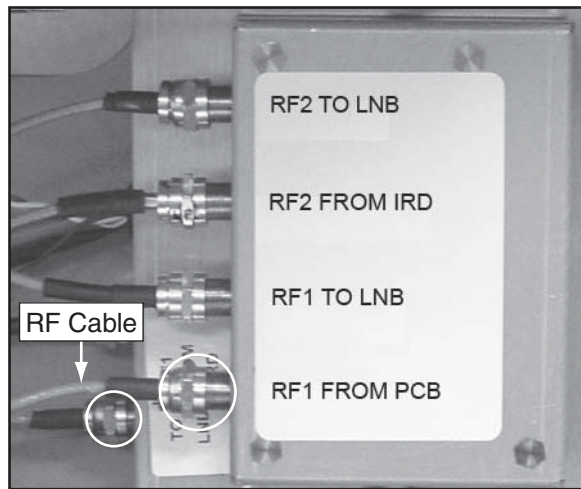
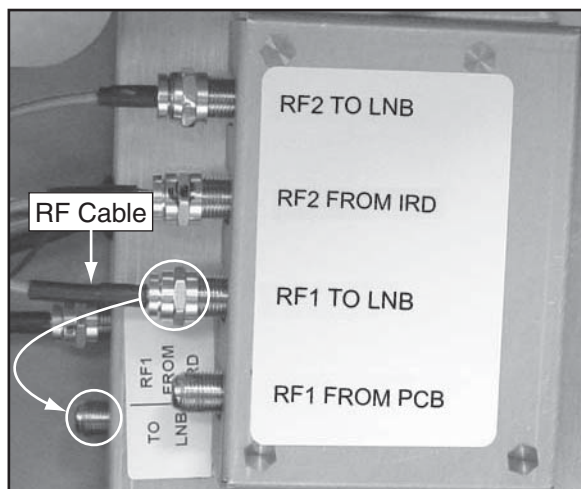

Figure 4: Moving the RF1 Cable



Continued Bypassing the Inverter PCB

- c. Apply an "RF2" label to the RF cable connected to the inverter PCB's "RF2 FROM IRD" connector (see Figure 5).
- d. Disconnect the two remaining RF cables from the inverter PCB (see Figure 5).
- e. Using wire cutters, cut and remove the tie-wrap securing the "RF2"-labeled cable (see Figure 6).
- f. Route the free end of the "RF2"-labeled cable to the LNB.
- g. Disconnect the RF cable from the LNB's RF2 connector (see Figure 7). Remove this cable from the antenna.
- h. Temporarily connect the "RF2"-labeled cable (from step f) to the LNB's RF2 connector.
- i. Apply an "RF1" label to the other RF cable that is connected to the LNB.

Figure 5: RF2 Cables

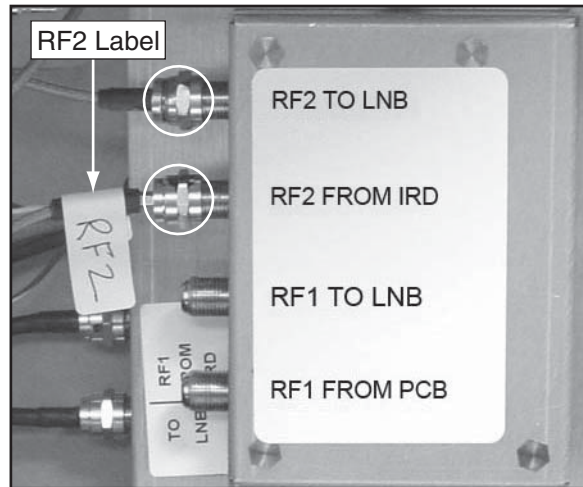

Figure 6: Tie-wrap Securing the "RF2"-labeled Cable

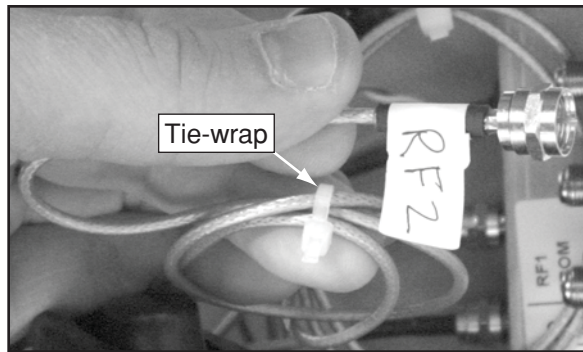
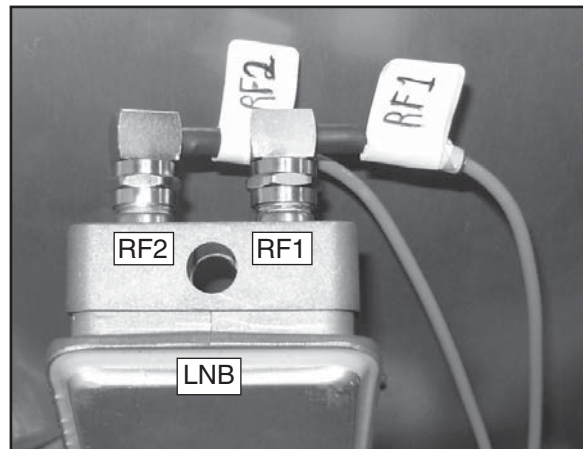

Figure 7: RF Connectors on Old LNB



Installing the Tri-Americas LNB

Follow these steps to disconnect and remove the old LNB and install the new Tri-Americas LNB in its place.

- a. Check the RF cables that are connected to the current LNB. Make sure the cables are labeled as shown in the associated figure (see Figure 8 through Figure 12). Label the cables as necessary.
- b. Disconnect the RF cables from the current LNB.

Figure 8: Linear Dual-output LNB

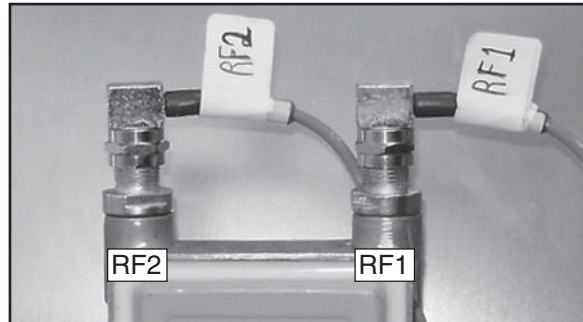

Figure 9: Linear Quad-output LNB

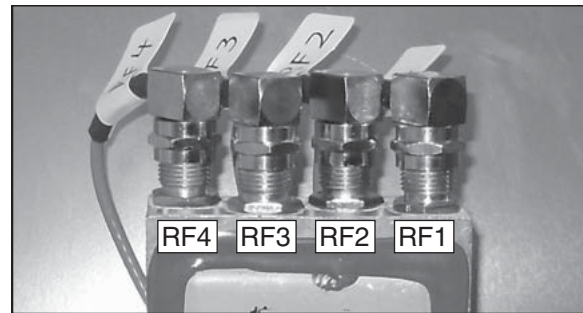

Figure 10: Compact Circular LNB

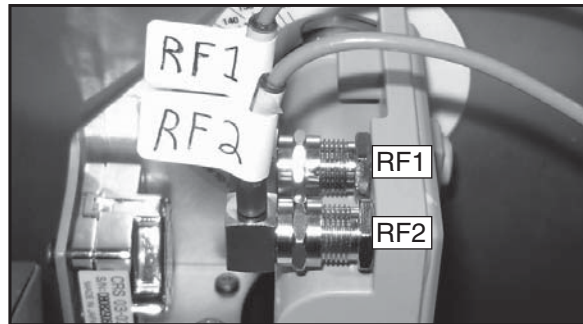

Figure 11: Conventional Circular LNB

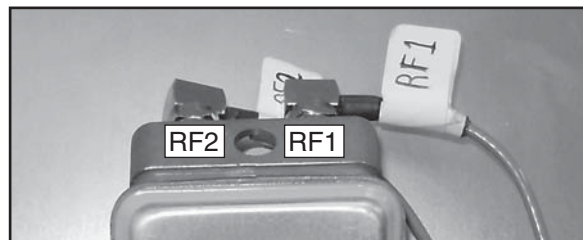
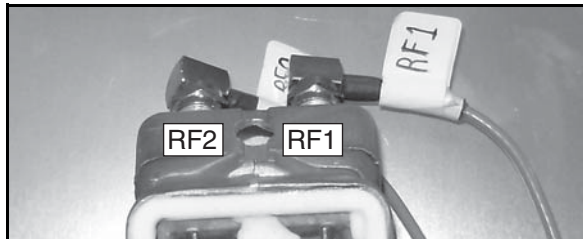

Figure 12: Galaxy LNB



Continued Installing the Tri-Americas LNB

- c. Connect the RF1 and RF2 cables to their corresponding connectors on the Tri-Americas LNB (Figure 13).
- d. **If you are replacing a linear quad-output LNB**, apply rubber caps over the connectors of the unused RF3 and RF4 cables to protect their center conductors (see Figure 13).
- e. **If the antenna has a serial number later than 080200980**: Using a 2 mm allen hex key, loosen the two M4 socket set screws securing the current LNB to the reflector (see Figure 14).
- f. Remove the old LNB.
- g. Insert the new Tri-Americas LNB fully into the choke feed with the connectors aligned upright.
- h. **If the antenna has a serial number later than 080200980**: Tighten the two M4 socket set screws to secure the LNB in place. Apply 9 in-lbs (1 Nm) of torque, if possible.

If your antenna has a serial number earlier than 080200981, loosen the two wing screws securing the current LNB to the reflector (see Figure 15).

Figure 13: Tri-Americas LNB

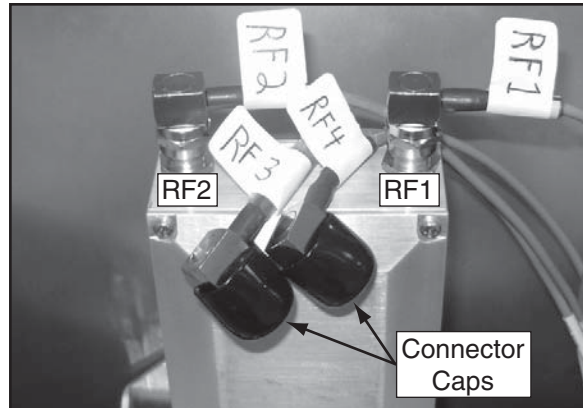

Figure 14: LNB Retaining Screws, Newer Antenna

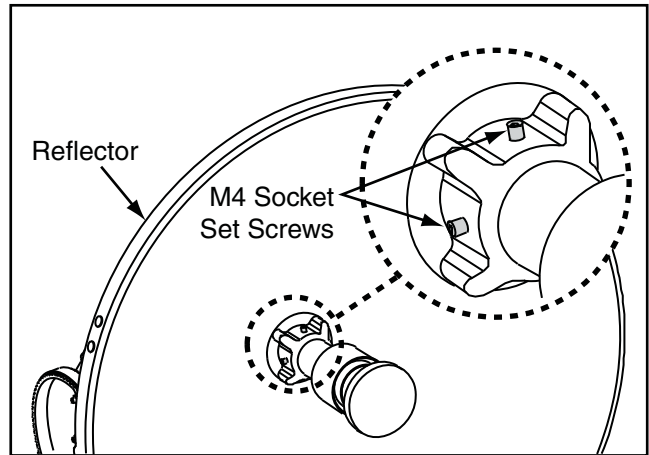
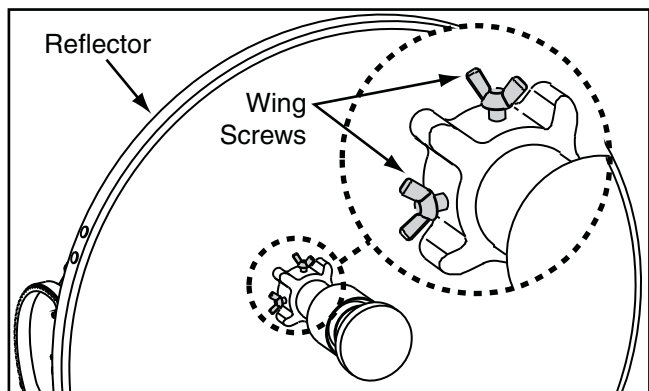

Figure 15: LNB Retaining Screws, Older Antenna



Continued Installing the Tri-Americas LNB

- i. Using four tie-wraps (*supplied in the kit*), secure the RF cables to each other to prevent them from getting snagged when the antenna is in motion (see Figure 16 and Figure 17).
- j. Reattach the radome (see Figure 1 on page 3).

Figure 16: Securing RF Cables

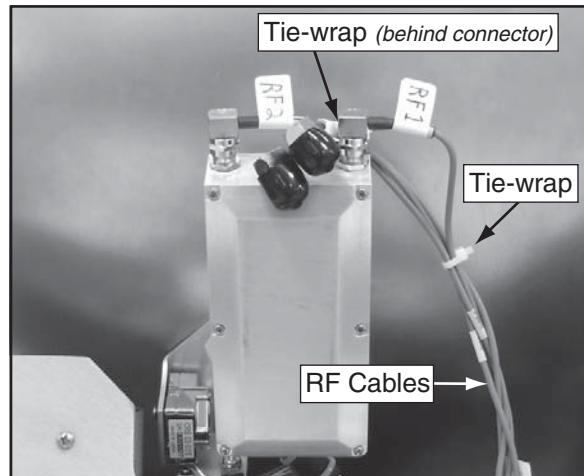
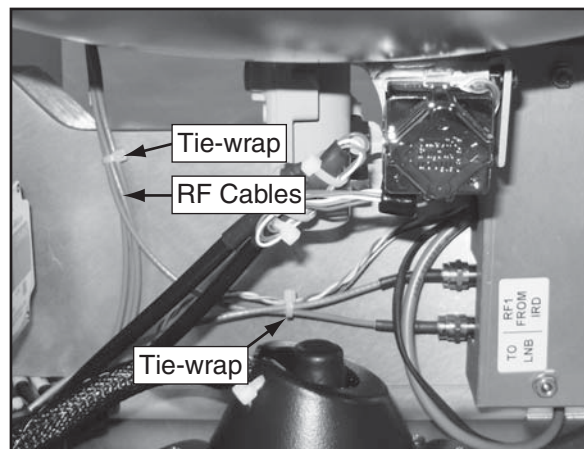

Figure 17: Securing RF Cables, Continued



Installing the Tone Generators

One or Two Receivers

Two 22KHz tone generators are supplied in the kitpack. Install these devices in-line with the antenna's RF cables as explained below. **If a multiswitch is installed, skip to page 10.**

- a. Disconnect the RF1 cable from the primary receiver's "Satellite In" connector.
- b. Connect the RF1 cable to the 22KHz tone generator's "LNB" connector.
- c. Connect a supplied RG-179 RF cable from the 22KHz tone generator's "REC" connector to the primary receiver's "Satellite In" connector.
- d. If you have a second receiver installed, repeat steps a-c to install the second 22KHz tone generator between the secondary receiver and the RF2 cable.
- e. Set the 22KHz tone generator's "22KHz OFF/ON" switch to the proper position for the satellite TV service you wish to receive:
OFF = DIRECTV, DISH Network, ExpressVu
ON = DIRECTV Latin America (Galaxy)
If you have two receivers installed, set the switch on both 22KHz tone generators.
- f. Reconnect power to the TracVision system components.
- g. Turn on the TracVision antenna and configure it to track satellites that are compatible with the Tri-Americas LNB. These include DIRECTV, DISH Network (EchoStar), ExpressVu, or Galaxy. Refer to the *TracVision M5/M7 User's Guide* for details.

Figure 18: Tone Generator Wiring

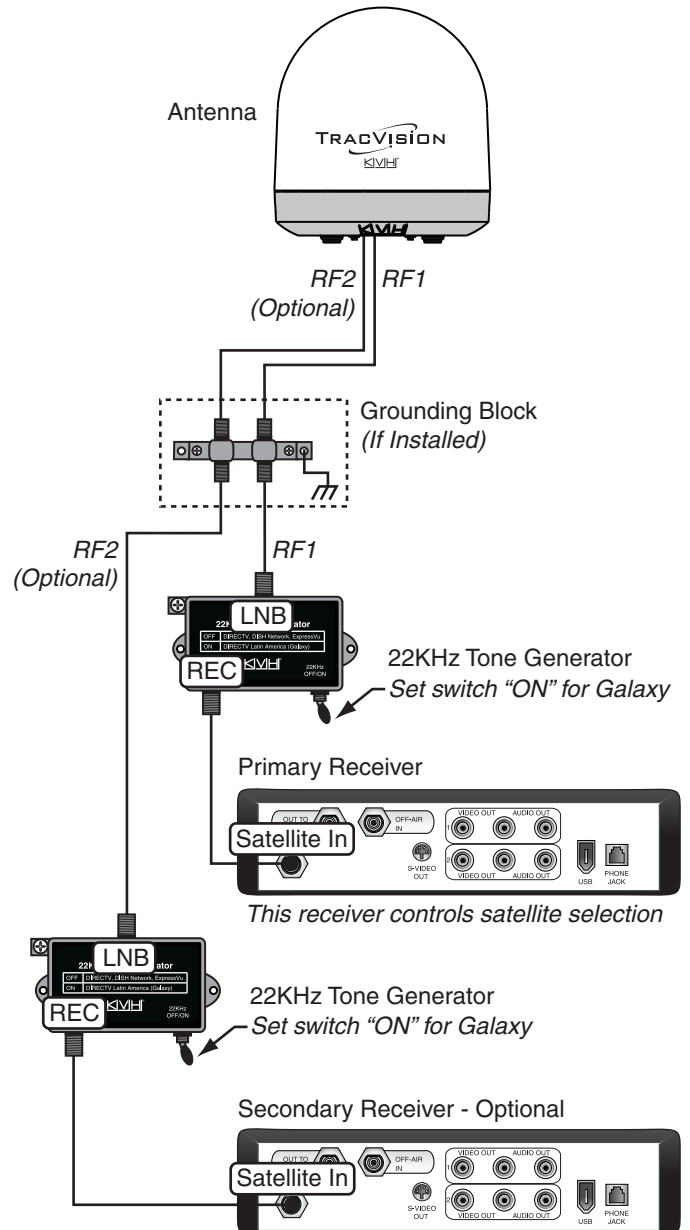

Installing the Tone Generators

Three or More Receivers

If a multiswitch is installed, follow these steps to install the supplied 22KHz tone generators.

- Disconnect the RF1 cable from the multiswitch's "13V" connector.
- Connect the RF1 cable to the 22KHz tone generator's "LNB" connector.
- Connect a supplied RG-179 RF cable from the 22KHz tone generator's "REC" connector to the multiswitch's "13V" connector.
- Disconnect the RF2 cable from the multiswitch's "18V" connector.
- Connect the RF2 cable to the second 22KHz tone generator's "LNB" connector.
- Connect a supplied RG-179 RF cable from the second 22KHz tone generator's "REC" connector to the multiswitch's "18V" connector.
- Set the "22KHz OFF/ON" switch on both 22KHz tone generators to the proper position for the satellite TV service you wish to receive:
OFF = DIRECTV, DISH Network, ExpressVu
ON = DIRECTV Latin America (Galaxy)
- Reconnect power to the TracVision system components.
- Turn on the TracVision antenna and configure it to track satellites that are compatible with the Tri-Americas LNB. These include DIRECTV, DISH Network (EchoStar), ExpressVu, or Galaxy. Refer to the *TracVision M5/M7 User's Guide* for details.

Figure 19: Tone Generator Wiring, Multiswitch Configuration

