

# TracVision® M9 LNB Conversion Instructions

---

## Technical Support

If you need technical assistance, please contact KVH Technical Support:

**North/South America, Australasia:**

Phone: +1 401 847-3327

E-mail: support@kvh.com

**Europe, Middle East, Asia-Pacific, Africa:**

Phone: +45 45 160 180

E-mail: support@emea.kvh.com

These instructions explain how to switch LNB types in a TracVision M9.

---

## Installation/Replacement Steps

1. Remove the Radome, 2
2. Identify LNB Types and Note Conversion Steps, 2
3. Bypass the Inverter PCB, 4
4. Install the Inverter PCB, 6
5. Install the Skew Motor Assembly, 10
6. Install the New Linear LNB, 15
7. Configure the New Linear LNB, 20
8. Install the New Circular LNB (After Bypassing the Inverter PCB), 21
9. Install New Satellites, 29

---

## Tools Required

This procedure requires the following tools:

- #1 Phillips screwdriver
- #2 Phillips screwdriver
- Cutting pliers
- 5/64" hex wrench
- 7/16" open-end wrench
- Digital level (or equivalent)
- PC with the latest version of the Flash Update Wizard installed

***TIP:** The Flash Update Wizard is available to KVH-authorized dealers through the KVH Partner Portal at [www.kvh.com/partners](http://www.kvh.com/partners).*

## Step 1 - Remove the Radome

Follow the steps below to remove the radome.



### CAUTION

For your own safety, be sure to disconnect power from all wired components before performing this procedure.

- Disconnect power from the TracVision system and any connected receivers and/or multiswitch.
- Remove the eight Phillips screws securing the radome to the baseplate. Then set the radome aside in a safe place.

## Step 2 - Identify LNB Types and Note Conversion Steps

There are several LNB types available; conversion procedures vary according to LNB types.

Refer to the table on the following page to determine the steps required for your LNB conversion.

Figure 1 TracVision M9 Radome Screws

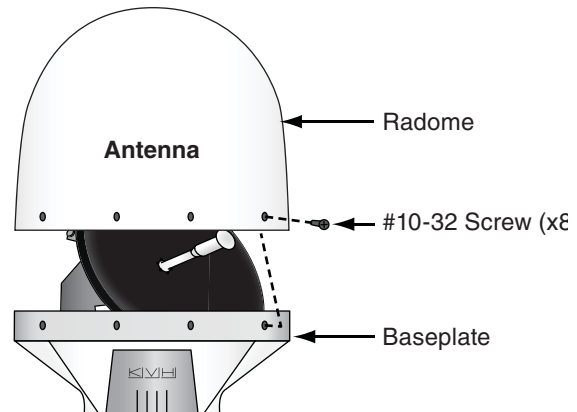
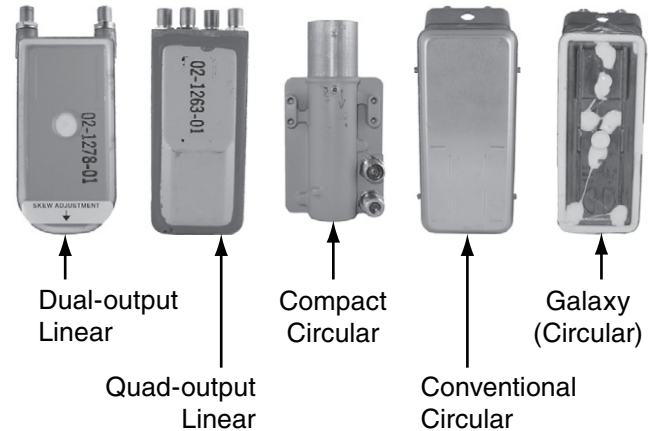

Figure 2 LNB Types



**Table 1: LNB Conversion Matrix**

<b>Convert From:</b>	<b>Convert To:</b>	<b>Complete Steps:</b>
Conventional Circular	Compact Circular	Step 3, pages 4 — 6 Step 8, pages 21 — 23
Conventional Circular	Galaxy	Step 10, pages 27 — 29 Step 11 on page 29
<ul style="list-style-type: none"> <li>• Conventional Circular</li> <li>• Galaxy</li> </ul>	<ul style="list-style-type: none"> <li>• Dual-output Linear</li> <li>• Quad-output Linear</li> </ul>	Step 3, pages 4 — 6 Step 5, pages 10 — 15 Step 6, pages 15 — 20 Step 7 on page 20 Step 11 on page 29
Galaxy	Compact Circular	Step 3, pages 4 — 6 Step 8, pages 21 — 23 Step 11 on page 29
Galaxy	Conventional Circular	Step 10, pages 27 — 29 Step 11 on page 29
<ul style="list-style-type: none"> <li>• Dual-output Linear</li> <li>• Quad-output Linear</li> </ul>	<ul style="list-style-type: none"> <li>• Conventional Circular</li> <li>• Galaxy</li> </ul>	Step 4, pages 6 — 9 Step 9, pages 24 — 26 Step 11 on page 29
<ul style="list-style-type: none"> <li>• Dual-output Linear</li> <li>• Quad-output Linear</li> </ul>	Compact Circular	Step 10, pages 27 — 29 Step 11 on page 29
<ul style="list-style-type: none"> <li>• Dual-output Linear</li> <li>• Quad-output Linear</li> </ul>	<ul style="list-style-type: none"> <li>• Dual-output Linear</li> <li>• Quad-output Linear</li> </ul>	Step 7 on page 20
Compact Circular	Compact Circular	Step 10 on page 27
Compact Circular	<ul style="list-style-type: none"> <li>• Dual-output Linear</li> <li>• Quad-output Linear</li> </ul>	Step 5, pages 10 — 15 Step 6, pages 15 — 20 Step 7 on page 20 Step 11 on page 29
Compact Circular	Galaxy	Step 4, pages 6 — 9 Step 10, pages 27 — 29 Step 11 on page 29

### Step 3 - Bypass the Inverter PCB

The following instructions explain how to bypass the inverter PCB. **Only perform this procedure if indicated in Table 1: LNB Conversion Matrix on page 3.**

- a. Using a 7/16" open-end wrench, disconnect both ends of the RF cable shown in Figure 3. Then remove the cable.
- b. Disconnect the RF cable from the inverter PCB's "RF1 TO LNB" connector and connect it to the RF connector shown in Figure 4.
- c. Using cutting pliers, cut and remove the tie-wrap securing the RF cables to the PCB module (see Figure 4).

Figure 3 "RF1 FROM PCB" RF Cable

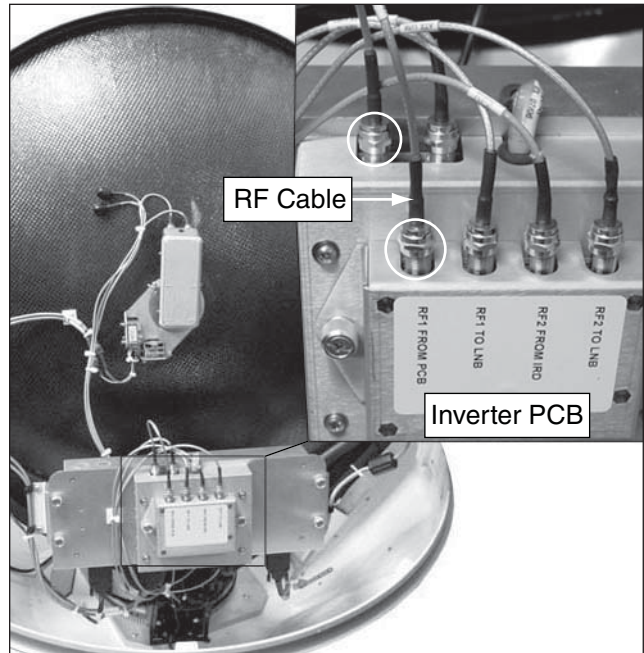
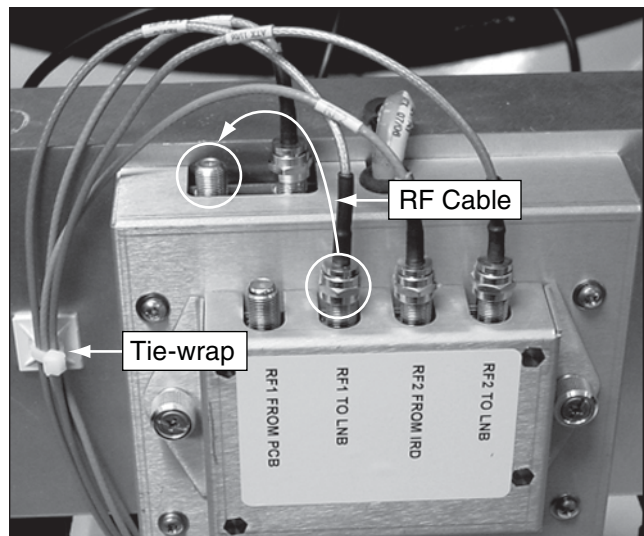

Figure 4 "RF1 TO LNB" RF Cable/Tie-wrap



- d. Disconnect the RF cable from the inverter PCB's "RF2 FROM IRD" connector (see Figure 5).
- e. Label the RF cable "RF2" (see Figure 6).
- f. Cut and remove the tie-wrap shown in Figure 7.

Figure 5 "RF2 FROM IRD" RF Cable

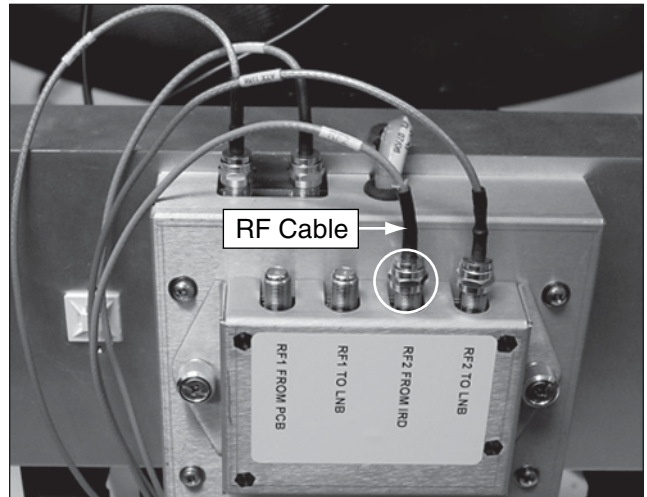

Figure 6 RF2 Label

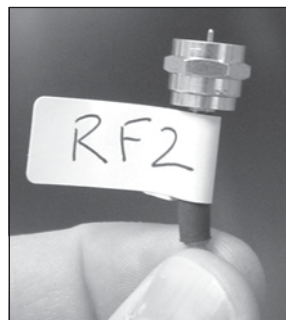
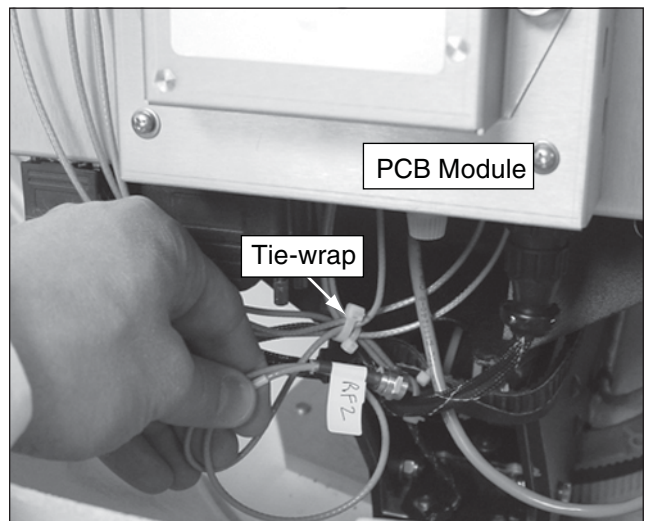

Figure 7 RF Cable/Tie-wrap



- g. Route the cable that you labeled “RF2” (in Step 3e. on page 5) up and behind the PCB module (see Figure 8). Rest the end of the cable on top of the PCB module. You will need to connect this cable to the new LNB later.
- h. Re-secure the remaining three RF cables using a supplied tie-wrap (see Figure 9).

### Step 4 - Install the Inverter PCB

The following instructions explain how to install the inverter PCB. **Only perform this procedure if indicated in Table 1: LNB Conversion Matrix on page 3.**

*NOTE: If the inverter PCB was installed during a previous LNB conversion, skip to Step 4c. on page 7.*

- a. Align the inverter PCB’s tab and retaining screws with the slot and screw holes located on the back of the antenna (see Figure 10).
- b. Using a #2 Phillips screwdriver, tighten the retaining screws to secure the inverter PCB to the mounting surface (see Figure 10).

Figure 8 Cable Routing

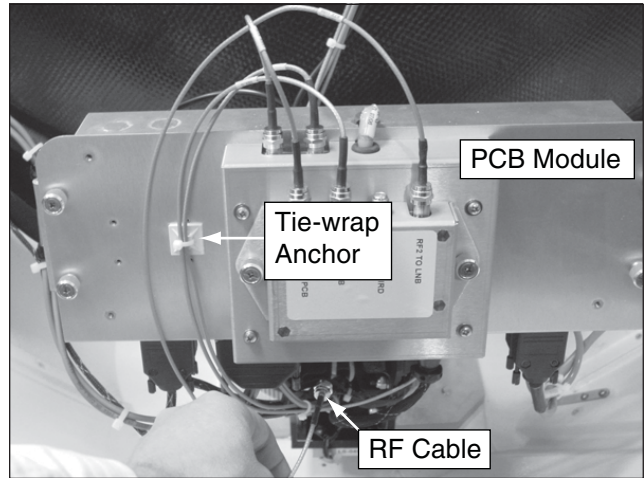

Figure 9 RF Cable Tie-wrap

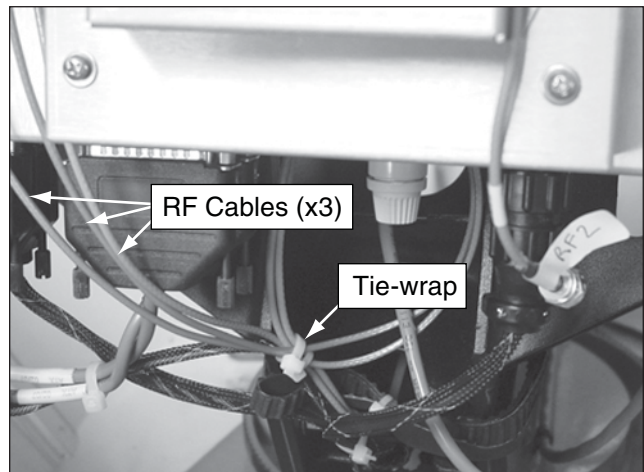
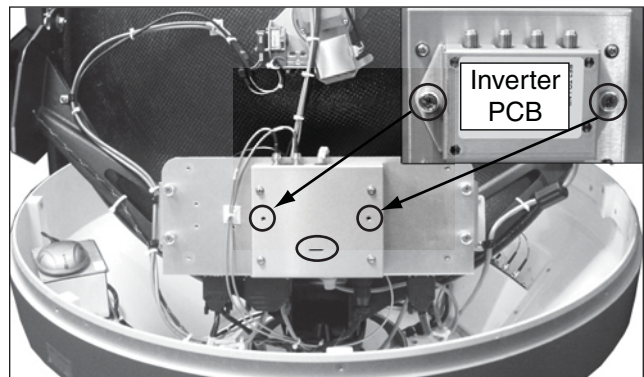

Figure 10 Inverter PCB Mounting



- c. Using a 7/16" open-end wrench, disconnect the RF cable shown in Figure 11. Then connect it to the inverter PCB's "RF1 TO LNB" connector.
- d. Remove the connector caps from the short RF cable supplied in the kitpack (see Figure 12). Then, using a 7/16" open-end wrench, connect the ends of the cable to the RF connectors shown in Figure 13.

Figure 11 "RF1 TO LNB" RF Cable

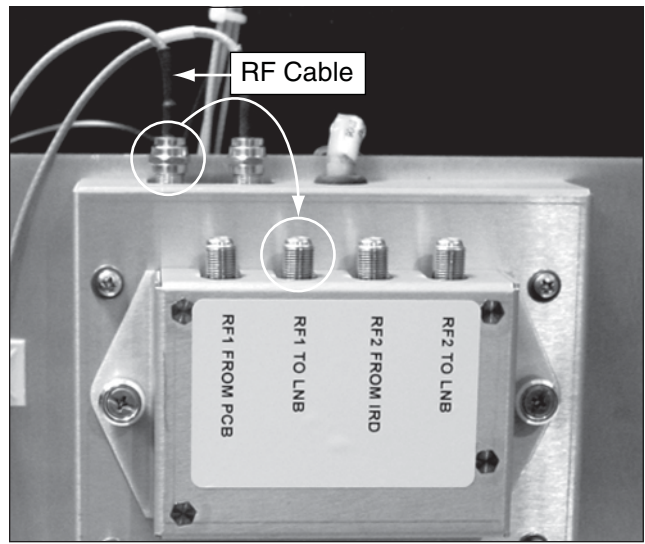

Figure 12 Short RF Cable/Connector Caps

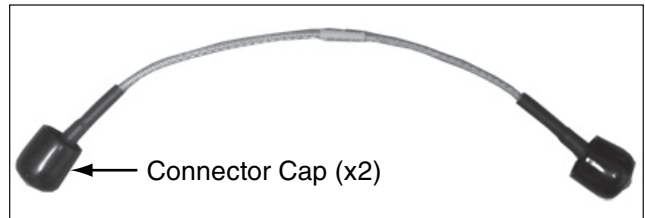
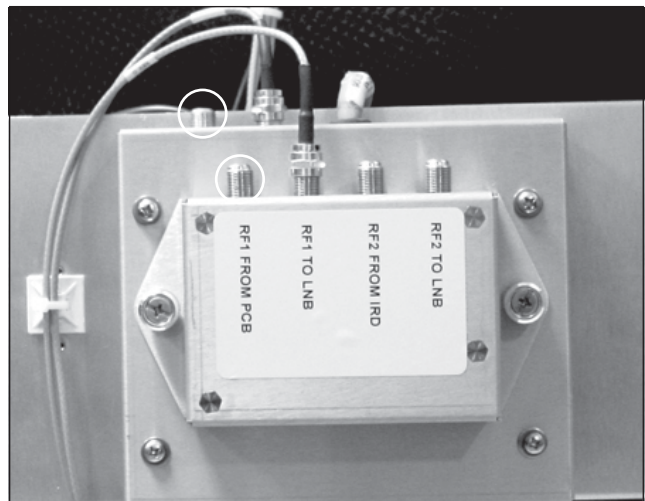

Figure 13 RF Cable Connections



e. Remove the connector caps from the long RF cable supplied in the kitpack (see Figure 14).

f. Connect one end of the long RF cable to the inverter PCB's "RF2 TO LNB" connector (see Figure 15).

*NOTE: If you performed a conversion previously, use the cable you secured previously (see Figure 48 on page 23).*

g. Apply a label to the other end of the cable. Mark the label "RF2" (see Figure 16).

Figure 14 Long RF Cable/Connector Caps

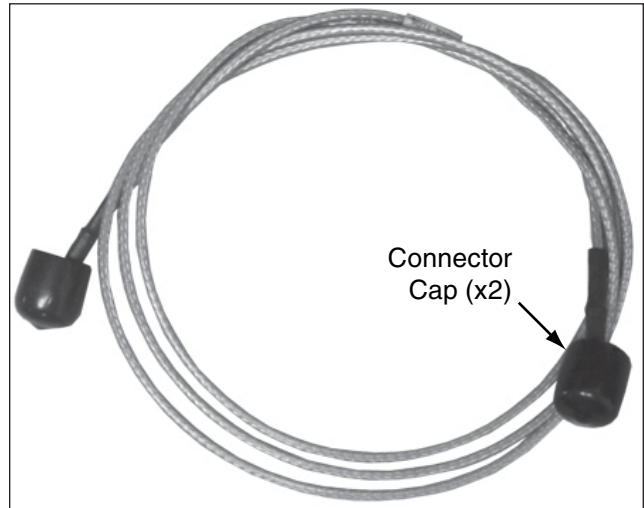

Figure 15 "RF2 TO LNB" Connector

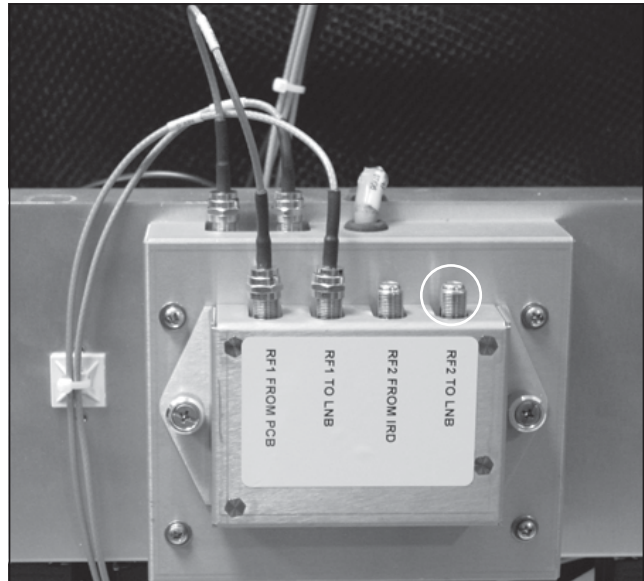
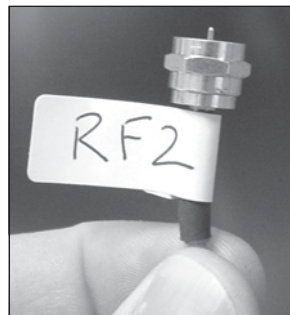

Figure 16 RF2 Label



- h.** Route the end of the cable that you labeled "RF2" along the tie-wrap anchor (located next to the inverter PCB) and under the PCB module (see Figure 17).
- i.** Route the cable behind the PCB module alongside the cable bundle (see Figure 18). Temporarily secure the cable with a tie-wrap on top of the PCB module; you will connect this cable to the RF2 connector on the new LNB later in this procedure.

Figure 17 "RF2 TO LNB" Cable Routing

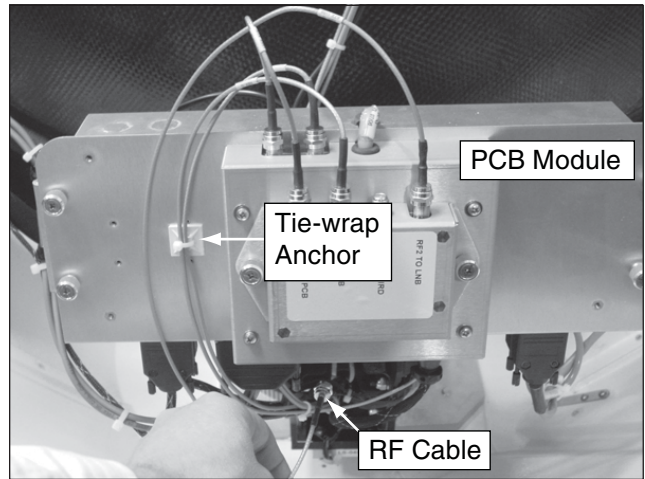
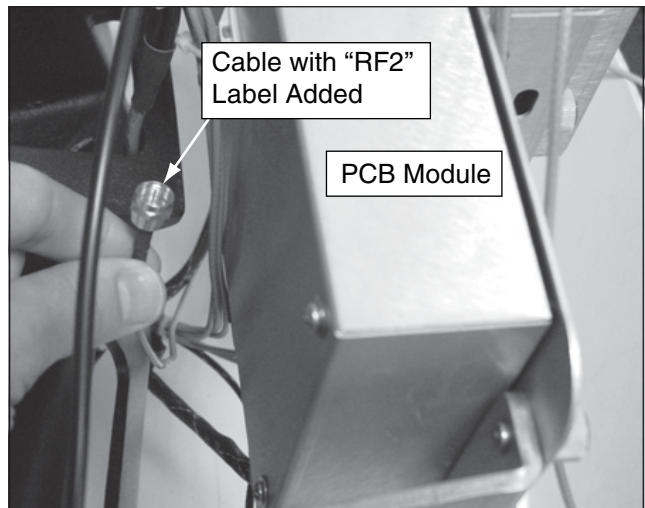

Figure 18 Cable Routing



## Step 5 - Install the Skew Motor Assembly

The following instructions explain how to install the skew motor assembly that is required when converting to a quad-output linear LNB. **Only perform this procedure if indicated in Table 1: LNB Conversion Matrix on page 3.**

- a. Using a 5/64" hex wrench, loosen the three hex screws securing the LNB to the choke feed. Then remove the LNB and set it aside in a safe place (see Figure 19).

*NOTE: Some antennas use wing screws instead of hex screws to secure the LNB to the choke feed.*

*NOTE: Do not disconnect the cables from the LNB at this time. You will remove them later. Be sure not to stress the cables while handling the detached LNB.*

- b. Using a 5/64" hex key, loosen the three hex screws securing the feed tube to the reflector. Then remove the feed tube and set it aside in a safe place (see Figure 20).
- c. Using a #2 Phillips screwdriver, remove the six screws securing the reflector bracket to the reflector (see Figure 20). Be sure to hold the reflector bracket (shown in Figure 19) while removing the screws.

Figure 19 Choke Feed Screws

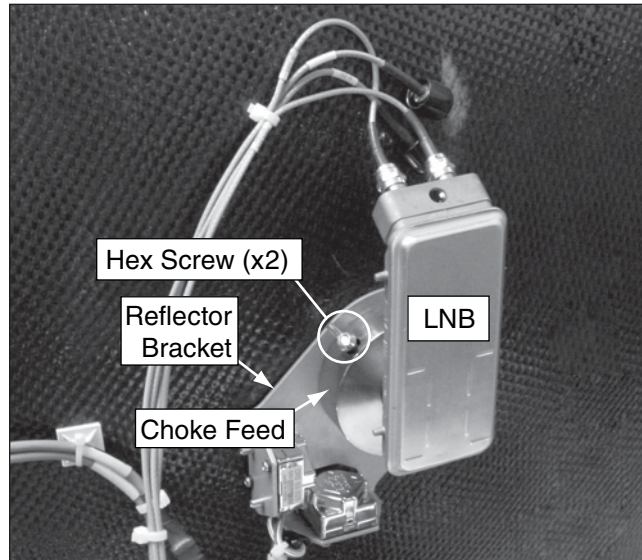
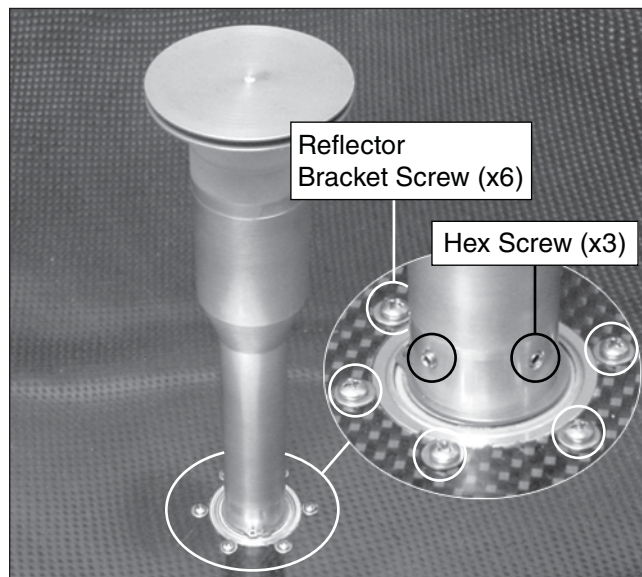

Figure 20 Feed Tube/Reflector Bracket Screws



- d. Using a #1 Phillips screwdriver, remove the screw securing the choke feed to the reflector bracket (see Figure 21). Then remove the choke feed and set it aside in a safe place.
- e. Locate the skew motor assembly supplied in the kitpack. Then mount the skew motor assembly onto the reflector bracket. Be sure to align all seven screw holes (see Figure 22).

Figure 21 Reflector Bracket/Choke Feed Screw

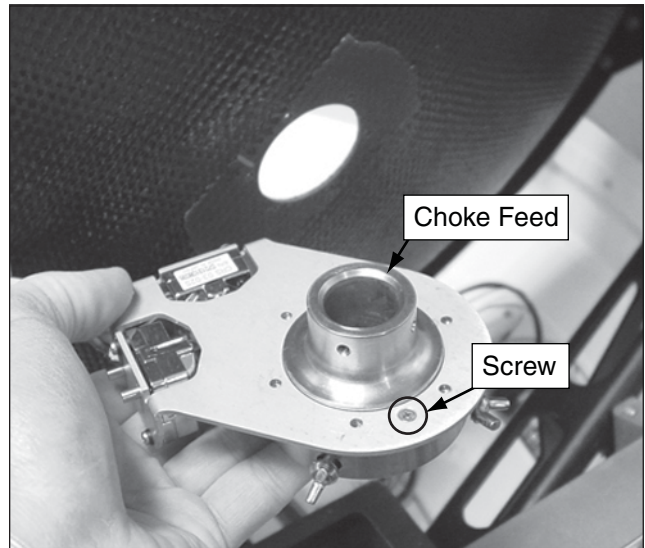
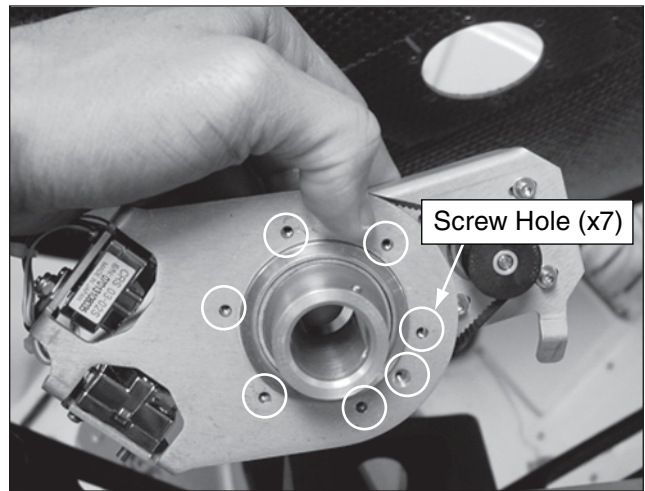

Figure 22 Screw Hole Alignment



- f. Secure the skew motor assembly to the reflector bracket using the screw you removed in Step 5d. on page 11 (see Figure 23).
- g. Insert the reflector bracket into the reflector, as shown in Figure 24.

*NOTE: Be sure to orient the reflector bracket as shown in Figure 24. Failure to properly orient the bracket will impair operation.*

Figure 23 Skew Motor Assembly Mounting Screw

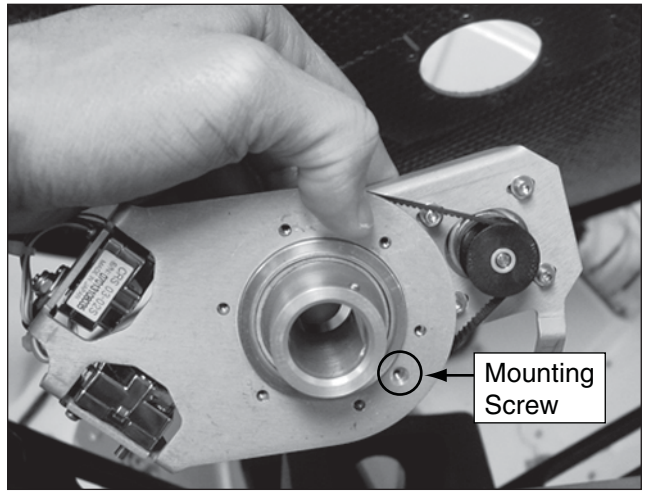
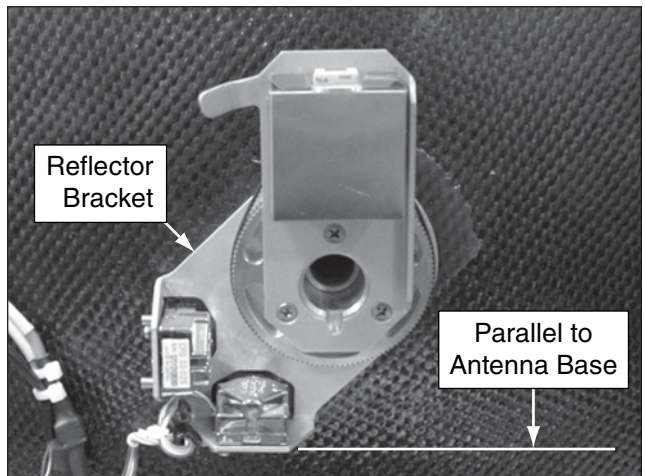

Figure 24 Reflector Bracket Orientation



- h. Secure the reflector bracket in place using the six screws you removed in Step 5c. on page 10 (see Figure 25).
- i. Reinstall the feed tube. Then tighten the two hex screws to secure it in place using a 5/64" hex key (see Figure 25).
- j. Locate the skew assembly cable supplied in the kitpack (see Figure 26).
- k. Connect the skew assembly cable's motor connector to the skew motor (see Figure 27).

Figure 25 Feed Tube/Reflector Bracket Screws

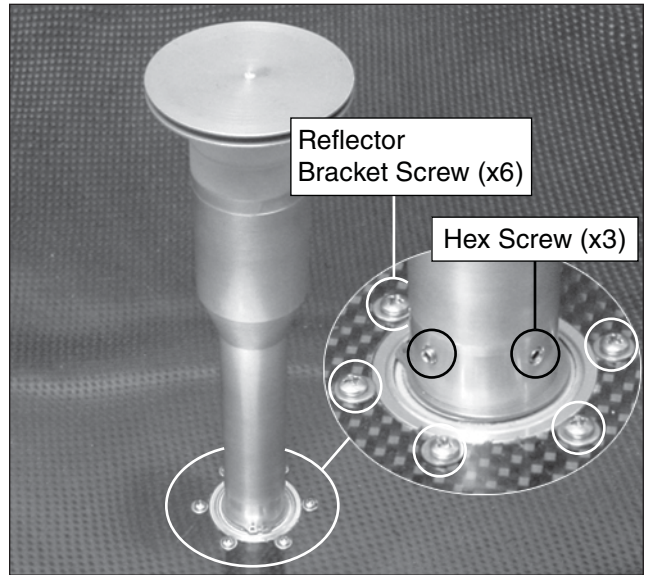

Figure 26 Skew Assembly Cable

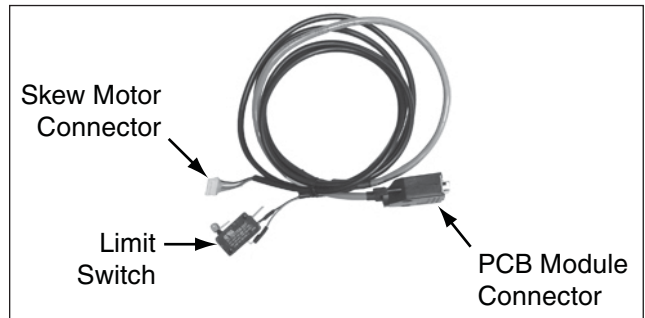
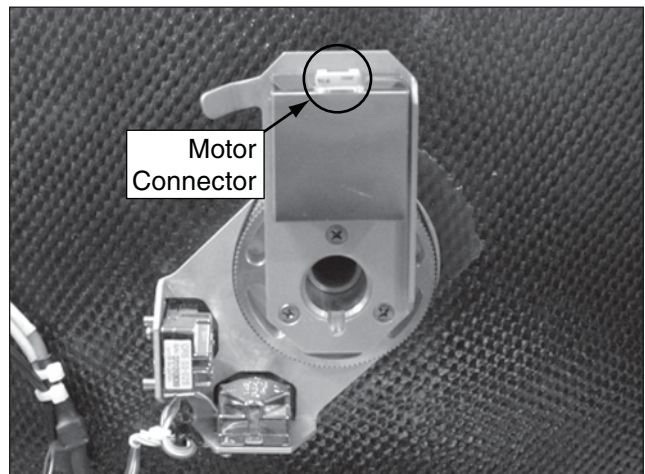

Figure 27 Motor Connector



- l. Mount the skew assembly cable's limit switch onto the standoffs. Ensure washers are installed on both sides of the limit switch screws (see Figure 28).

*NOTE: Be sure to place washers on both sides of the limit switch.*

- m. Using a #1 Phillips screwdriver, tighten the two screws to secure the limit switch to the standoffs.

*NOTE: To avoid damage, do not overtighten the limit switch screws.*

- n. Using four supplied tie-wraps, secure the limit switch cable at tie-wrap locations 1-4. Then cut and remove the tie-wraps at locations A and B (see Figure 29).
- o. Route the PCB module connector-end of the skew assembly cable through the antenna frame's access hole (see Figure 30).

Figure 28 Limit Switch Mounting

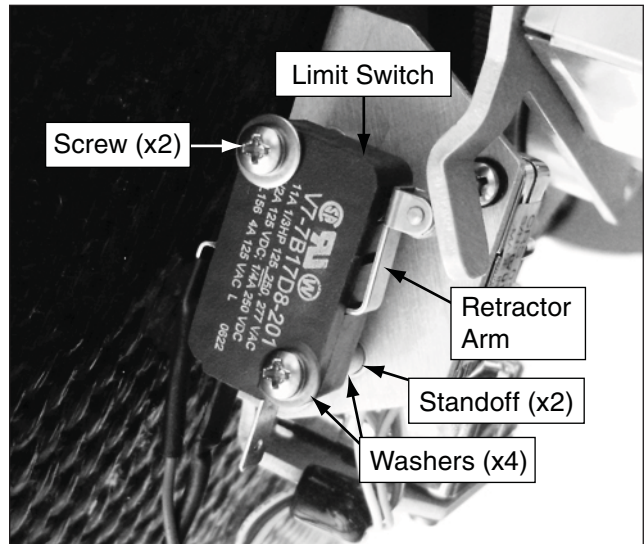

Figure 29 Limit Switch Cable Tie-wraps

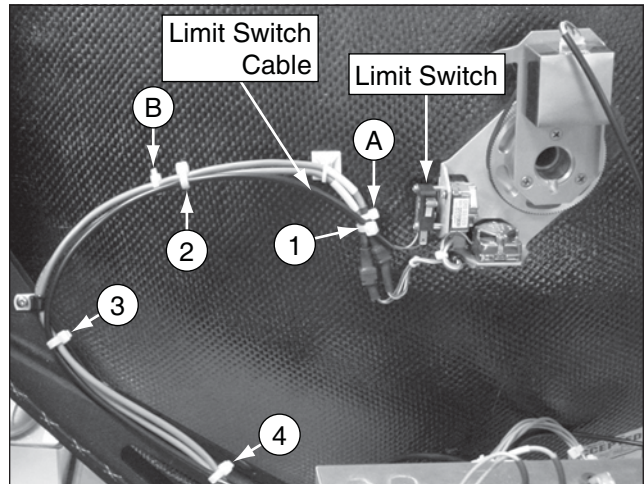
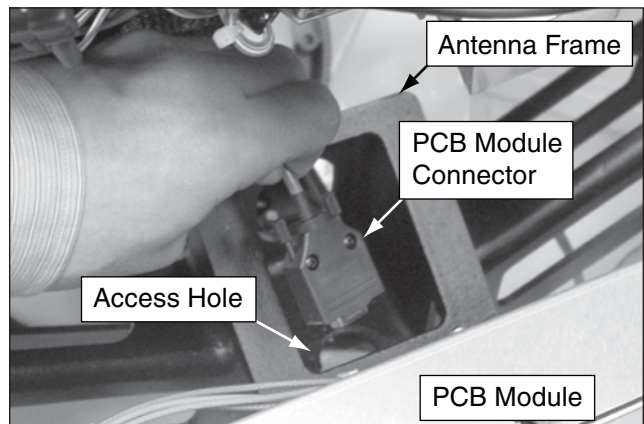

Figure 30 Antenna Frame Access Hole



- p. Connect the skew assembly cable's PCB module connector to the PCB module (see Figure 31).

## Step 6 - Install the New Linear LNB

The following instructions explain how to install a linear LNB. To ensure proper operation, you will need to align the LNB using a digital level (or equivalent). **Only perform this procedure if indicated in Table 1: LNB Conversion Matrix on page 3.**

- a. Insert the linear LNB fully into the choke feed. Then align the LNB with the skew motor surface to ensure proper positioning (see Figure 32).
- b. Using a 5/64" hex key, tighten the choke feed screws to secure the LNB in place.

*NOTE: Some antennas use wing screws instead of hex screws to secure the LNB to the choke feed.*

- c. Rotate the skew assembly counter-clockwise, until the limit switch prevents further rotation, as shown in Figure 32. This will ensure a stable measuring surface in the following step.
- d. Using a digital level, ensure there is no more than a 1° difference between the angle of each measuring surface. Readjust and re-measure the LNB as necessary.
- e. Using a digital level, measure and record the angle of the LNB's measuring surface (see Figure 32).

*NOTE: The digital level always displays positive angles. However, the antenna skew mechanism regards angles clockwise from vertical as negative and counterclockwise from vertical as positive (see Figure 34 on page 16).*

- a. Reconnect power to the TracVision system. Then connect a PC to the TracVision system.

*NOTE: Connection instructions vary. Refer to the Flash Update Wizard's Help file for connection instructions (see Figure 33).*

Figure 31 Skew Assembly Connector

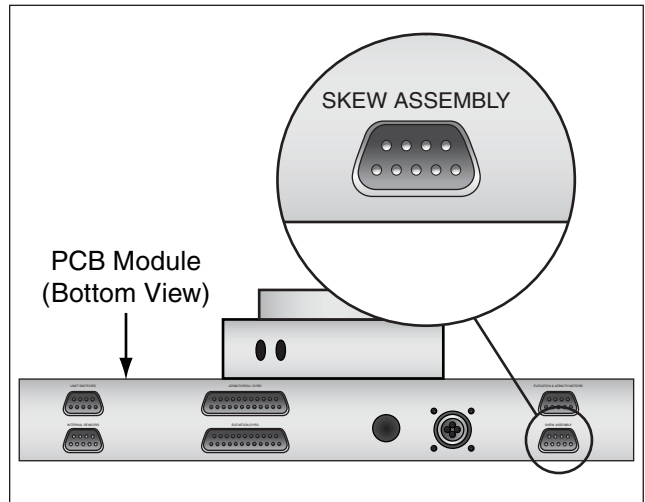

Figure 32 LNB Alignment

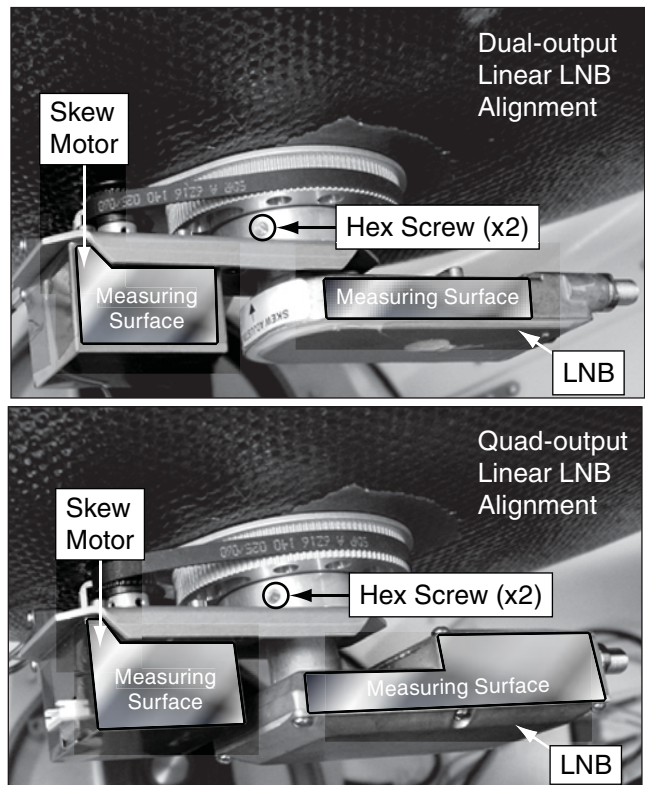

Figure 33 Flash Update Wizard Help



b. Open the Flash Update Wizard. Then turn on the TracVision system.

c. Type the following command into the wizard's "Command" box. Then press Enter.

**=CALSKEW,XX.X**

*NOTE: XX.X = the LNB angle you just recorded.*

*NOTE: If the angle you recorded is a negative number, be sure to use a negative (-) sign when entering the angle. For example, if the digital level measures 10.5°, and it is angled clockwise from vertical, you would type =CALSKEW,-10.5.*

Figure 34 Positive/Negative Skew Angles

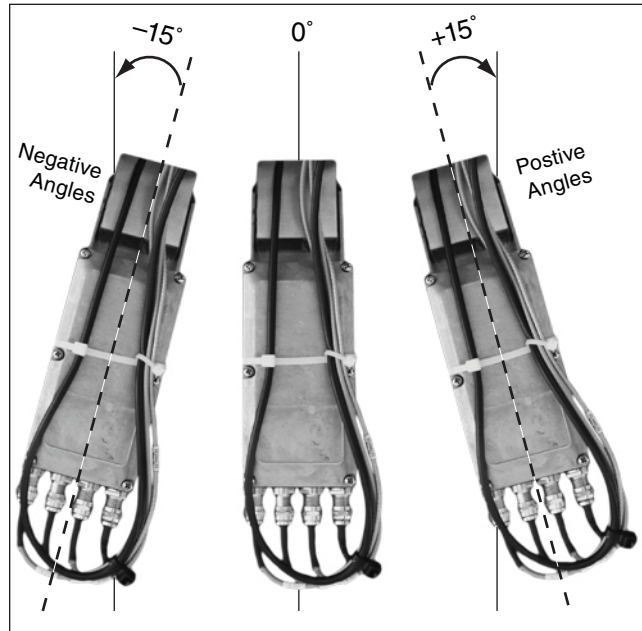

- d. Using a 7/16" open-end wrench, connect the RF cable that you rerouted and labeled "RF2" and rerouted (see Step 3g. on page 6) to the RF2 connector on the new LNB (see Figure 35).
- e. Disconnect the RF cable connected to the original LNB's RF1 connector and connect it to the new LNB's RF1 connector (see Figure 35).

Figure 35 Cable Transfers from Old LNB to New LNB

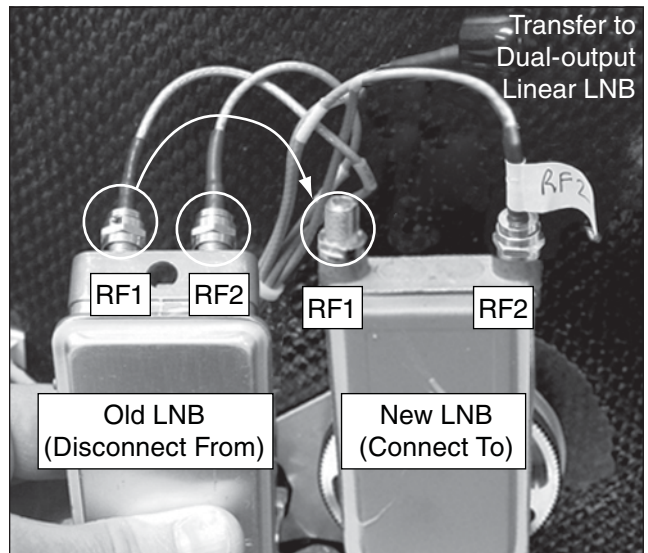
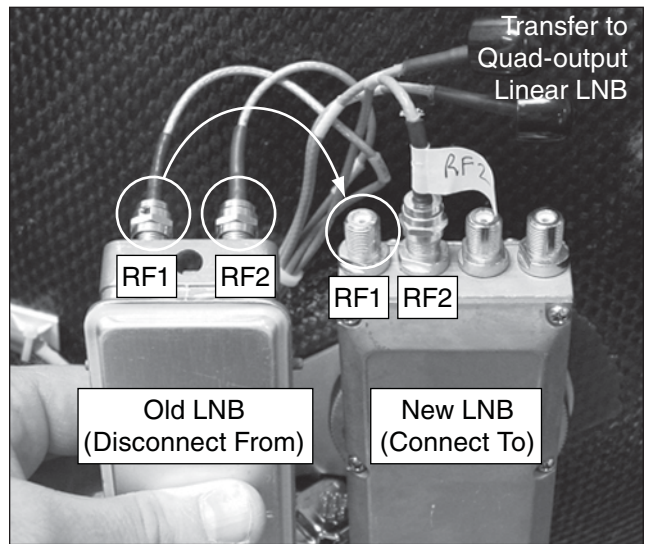

- f. Disconnect the RF cable connected to the original LNB's "RF2" connector (see Figure 35 on page 17). Add a connector cap onto the end of the cable. Then, using a tie-wrap, secure the cable to the cable bundle (see Figure 36).
- g. If you are connecting to a quad-output linear LNB, remove the connector caps from the RF3 and RF4 cables (see Figure 36). Then connect the cables to the LNB's RF3 and RF4 connectors.

**TIP:** The RF3 and RF4 cables are already labeled.

**TIP:** For storage purposes, connect both ends of the short RF cable (removed in Step 3d. on page 5) to the original LNB's connectors, as shown in Figure 37. Then store the LNB and cable in a safe place.

Figure 36 Cable Connections/Tie-wrap

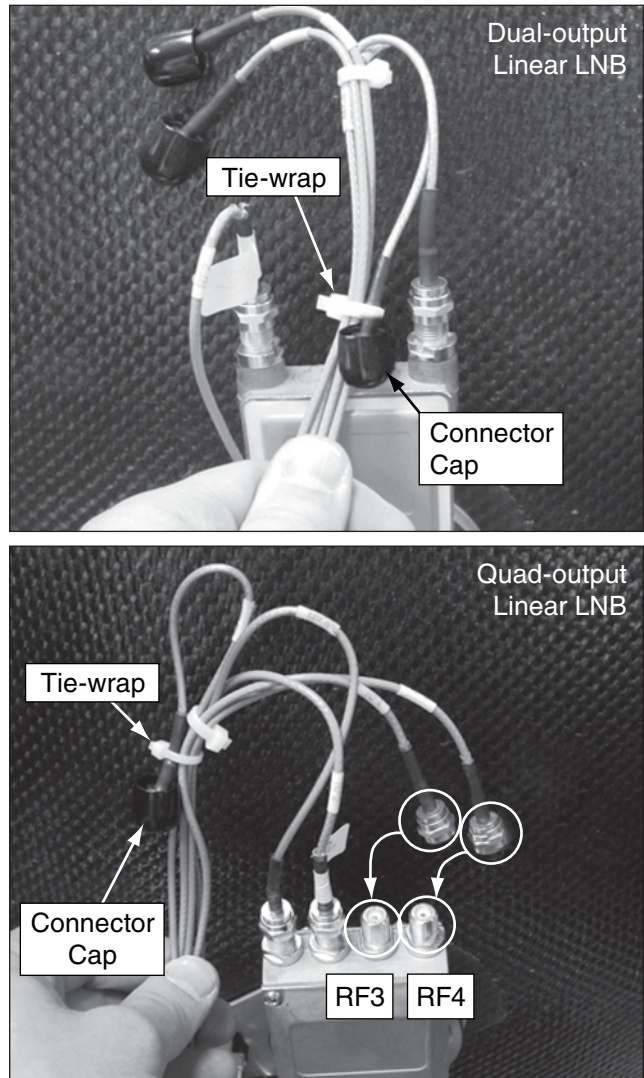
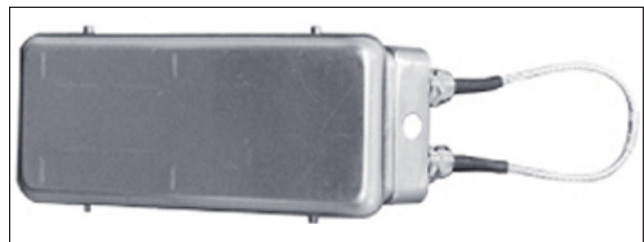
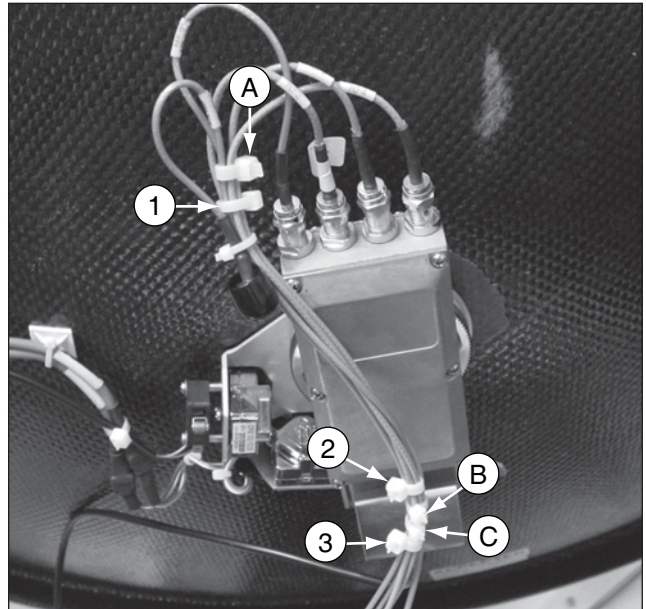

Figure 37 Original LNB/Cable Storage



- h.** Using three supplied tie-wraps, secure the RF2 cable to the cable bundle at tie-wrap locations 1-3 (see Figure 38). Then, using cutting pliers, cut and remove the original tie-wraps (locations A-C).
- i.** Using a large supplied tie-wrap, secure the skew assembly cable and the cable bundle to the LNB as shown in Figure 39.

**Figure 38 Quad-output Linear LNB Tie-wraps**



**Figure 39 Cables/Tie-wrap**

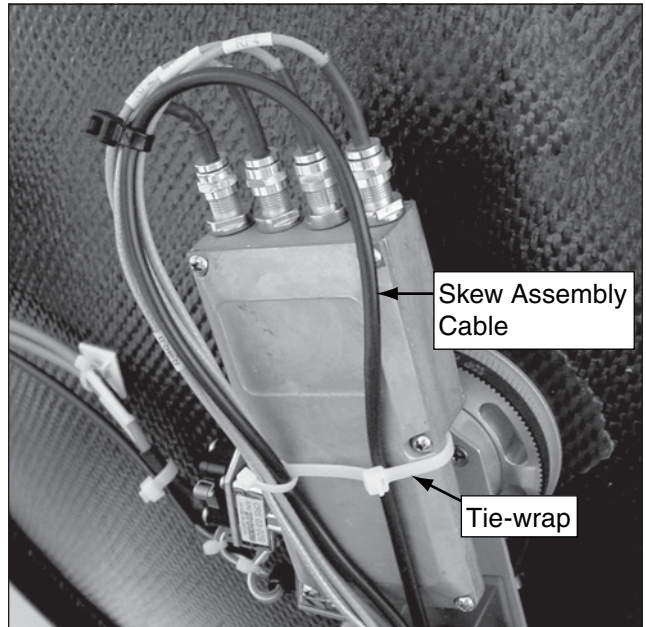

- j. Using two supplied tie-wraps, secure the limit switch cable and RF2 cable to the cable bundle at location 1 and secure the three RF cables at location 2. Then cut and remove the tie-wrap at location A.
- k. Reinstall the radome.

## Step 7 - Configure the New Linear LNB

The following instructions explain how to configure the antenna to use the new linear LNB. **Only perform this procedure if indicated in Table 1: LNB Conversion Matrix on page 3.**

- a. Reconnect power to the TracVision system. Then connect a PC to the TracVision system.

*NOTE: Connection instructions vary. Refer to the Flash Update Wizard's Help file for connection instructions (see Figure 41).*

- b. Open the Flash Update Wizard. Then turn on the TracVision system. Wait two minutes for system startup.
- c. Type the following commands into the wizard's "Command" box. Press Enter after each command.

**HALT  
DEBUGON  
SKEWMTRON  
ZAP**

- d. The antenna will restart. Wait two minutes for system startup.
- e. Type the following commands into the wizard's "Command" box. Press Enter after each command.

**HALT  
DEBUGON  
EL,0  
SKEW,0**

Figure 40 Tie-wrap Locations

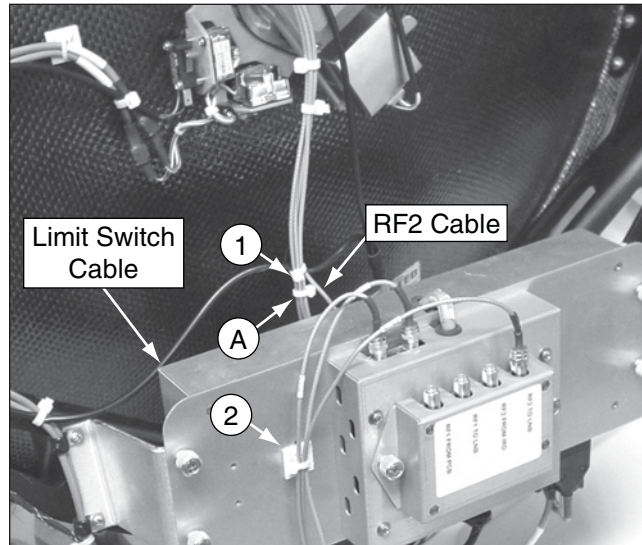
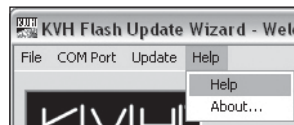

Figure 41 Flash Update Wizard Help



## Step 8 - Install the New Circular LNB (After Bypassing the Inverter PCB)

The following instructions explain how to install a compact circular LNB. **Only perform this procedure if indicated in Table 1: LNB Conversion Matrix on page 3.**

- a. Reconnect power to the TracVision system. Then connect a PC to the TracVision system.

*NOTE: Connection instructions vary. Refer to the Flash Update Wizard's Help file for connection instructions (see Figure 42).*

- b. Open the Flash Update Wizard. Then turn on the TracVision system. Wait two minutes for system startup.
- c. Type the following commands into the wizard's "Command" box. Press Enter after each command.

**HALT  
DEBUGON  
SKEWMTROFF  
ZAP**

### **IMPORTANT!**

Failure to enter these antenna commands can cause serious damage to the antenna.

- d. The antenna will restart. Wait two minutes for system startup.
- e. Disconnect power from the TracVision system and any connected receivers and/or multiswitch.
- f. Using a 7/16" open-end wrench, connect the RF cable (shown in Figure 43) that you rerouted and labeled "RF2" (see Step 3g. on page 6) to the RF2 connector on the new LNB (see Figure 44).
- g. Disconnect the RF cable connected to the original LNB's RF1 connector and connect it to the RF1 connector on the new LNB (see Figure 44).

Figure 42 Flash Update Wizard Help

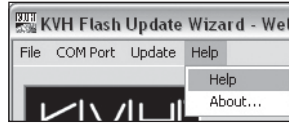

Figure 43 RF2 Cable Connection From Installed or Bypassed Inverter PCB

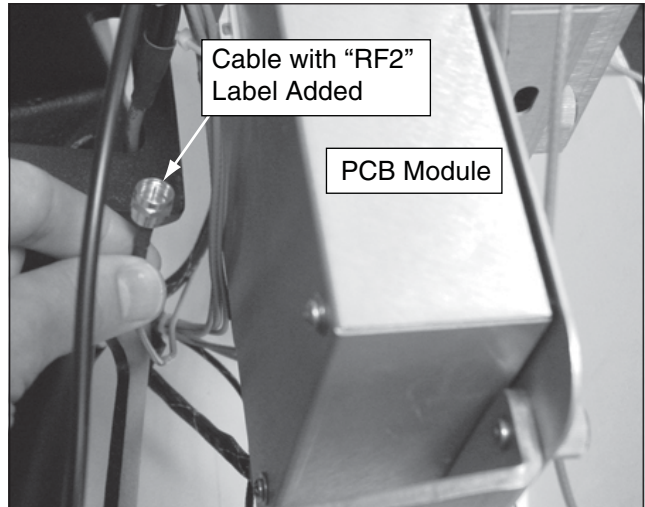
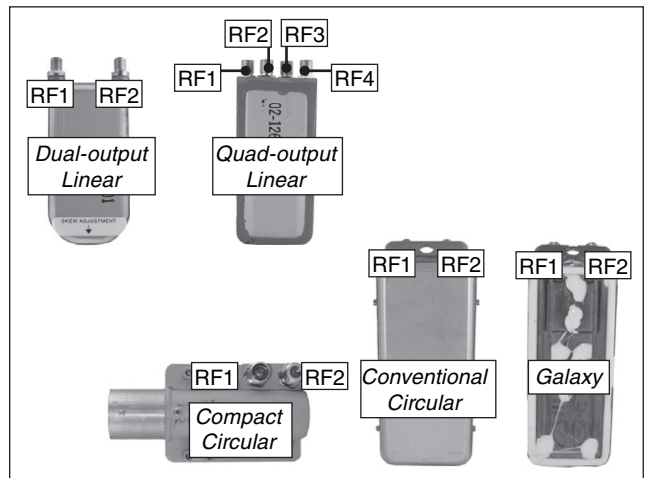

Figure 44 LNB Cable Connections



- h. Disconnect the original LNB's RF2 cable. Then secure the cable to the cable bundle, as shown in Figure 45.
- i. Using a 5/64" hex key, loosen the two hex screws securing the LNB to the choke feed (see Figure 46).

*NOTE: Some antennas use wing screws instead of hex screws to secure the LNB to the choke feed.*

- j. Remove the original LNB and store it in a safe place.
- k. Insert the new LNB fully into the choke feed. Then tighten the two hex screws on the choke feed to secure the LNB in place (see Figure 46).

Figure 45 RF Cable Tie-wrap

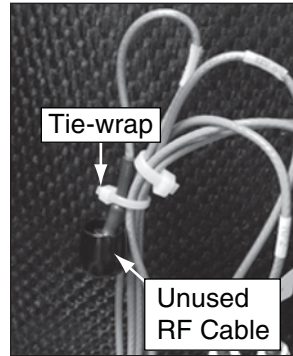
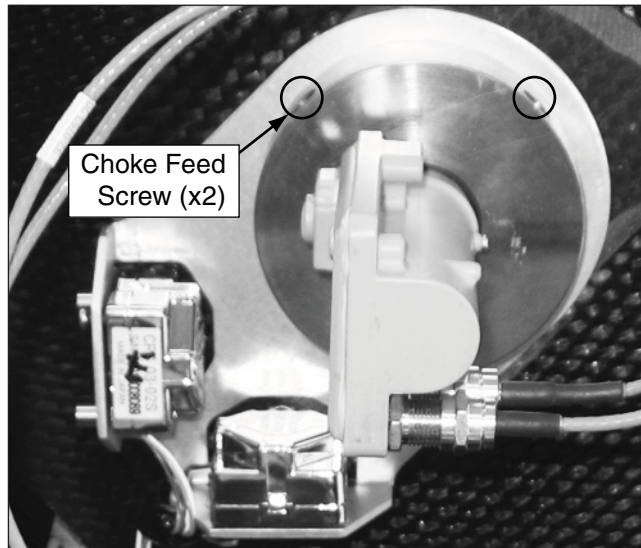

Figure 46 Choke Feed Screws



- l. Secure the RF cables using three tie-wraps, as shown in Figure 47.
- m. Create a cable loop to eliminate excess slack in the unused RF cables that you disconnected from the original LNB. Then secure the RF cables with a tie-wrap to the PCB module (see Figure 48).
- n. Gently tilt the antenna reflector up and down to ensure enough cable slack is present to allow unhindered vertical travel.

Figure 47 Compact Circular Tie-wrap Locations

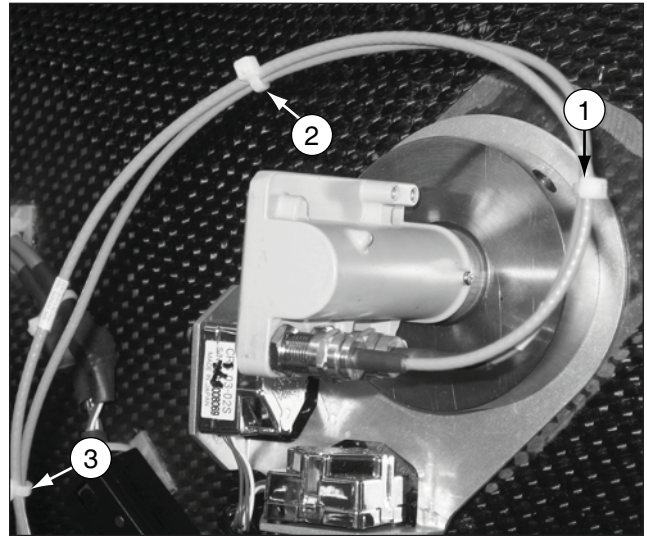
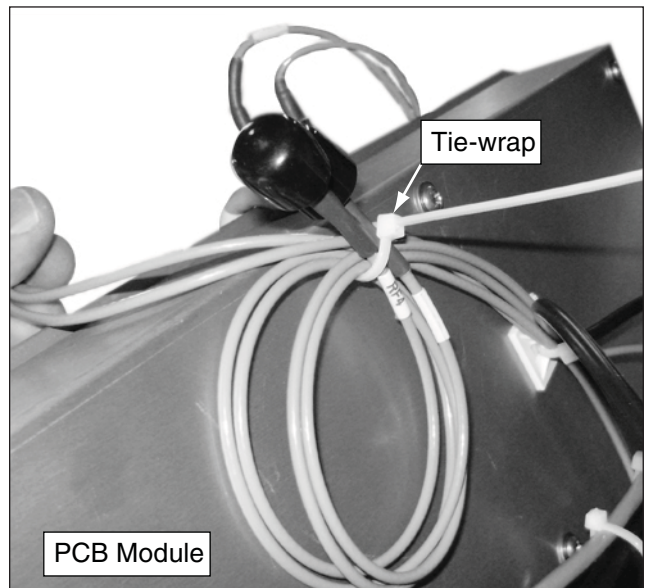

Figure 48 Excess Cable



## Step 9 - Install the New Circular LNB (After Installing the Inverter PCB)

The following instructions explain how to install a galaxy or conventional circular LNB. **Only perform this procedure if indicated in Table 1: LNB Conversion Matrix on page 3.**

- a. Reconnect power to the TracVision system. Then connect a PC to the TracVision system.

*NOTE: Connection instructions vary. Refer to the Flash Update Wizard's Help file for connection instructions (see Figure 49).*

- b. Open the Flash Update Wizard. Then turn on the TracVision system. Wait two minutes for system startup.
- c. Type the following commands into the wizard's "Command" box. Press Enter after each command.

**HALT  
DEBUGON  
SKEWMTROFF  
ZAP**

### **IMPORTANT!**

Failure to enter these antenna commands can cause serious damage to the antenna.

- d. The antenna will restart. Wait two minutes for system startup.
- e. Disconnect power from the TracVision system and any connected receivers and/or multiswitch.
- f. Using a 7/16" open-end wrench, connect the RF cable that you rerouted and labeled "RF2" (see Step 3g. on page 6 and Step 4i. on page 9) to the RF2 connector on the new LNB (see Figure 51).

Figure 49 Flash Update Wizard Help

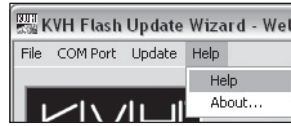

Figure 50 RF2 Cable Connection From Installed or Bypassed Inverter PCB

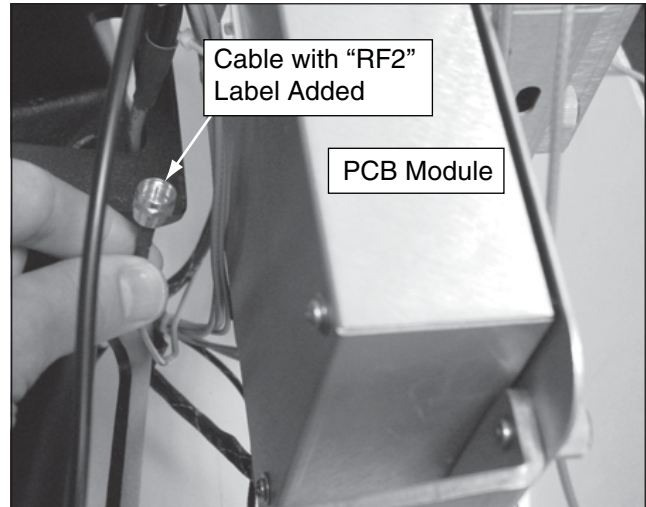
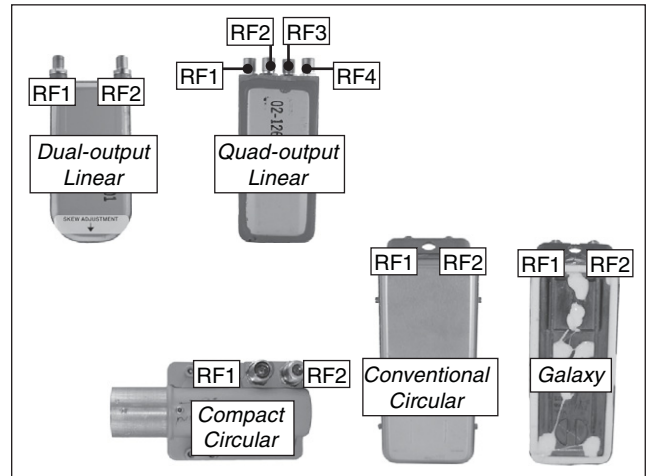

Figure 51 LNB Cable Connections



- g. Disconnect the RF cable connected to the original LNB's RF1 connector and connect it to the RF1 connector on the new LNB (see Figure 51 on page 24).
- h. Remove any tie-wraps and disconnect the RF cable connected to the original LNB's RF2 connector. Connect the RF cable to the inverter PCB's "RF2 FROM IRD" connector (see Figure 52).
- i. Using a 5/64" hex key, loosen the two hex screws securing the original LNB to the choke feed (see Figure 53).

*NOTE: Some antennas use wing screws instead of hex screws to secure the LNB to the choke feed.*

- j. Remove the original LNB and store it in a safe place.
- k. Insert the new LNB fully into the choke feed. Then tighten the two hex screws on the choke feed to secure the LNB in place (see Figure 54).
- l. **If you are switching from a linear LNB,** secure the skew motor cable to the LNB using a large tie-wrap, as shown in Figure 54.

*NOTE: Be sure to position the tie-wrap and the skew motor cable as shown in Figure 54.*

Figure 52 RF2 to "RF2 From IRD"

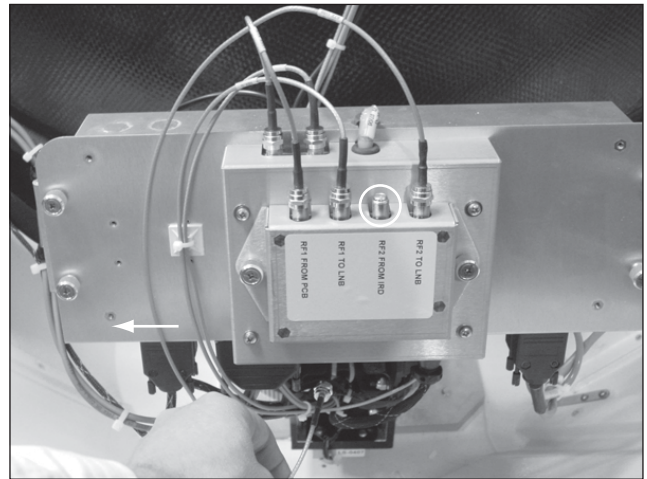

Figure 53 Choke Feed Screws

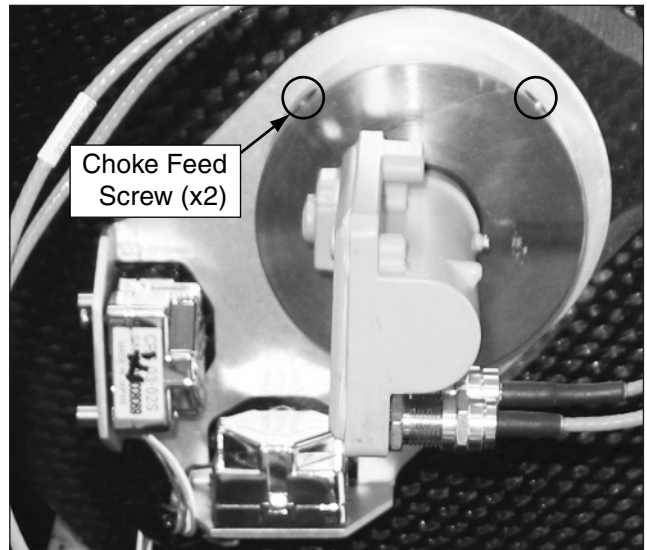
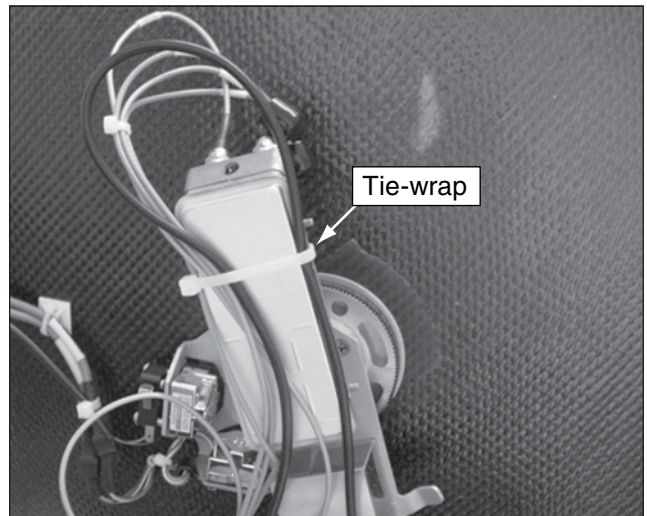

Figure 54 Galaxy/Conventional Circular LNB Tie-wrap Location



m. Secure the RF cables connected to the LNB with five tie-wraps at the locations shown in Figure 55.

n. Create a cable loop to eliminate excess slack in the RF cable connected to the inverter PCB's "RF2 FROM IRD" connector. Then secure the RF cable with a tie-wrap at location 1 as shown in Figure 56.

**If the original LNB was a quad-output linear LNB**, capture the RF3 and RF4 cables in the same tie-wrap at location 1.

o. **If the original LNB was a quad-output linear LNB**, create a second cable loop to eliminate excess slack in the unused RF3 and RF4 cables that you disconnected. Then secure the RF3 and RF4 cables with three tie-wraps at locations 2-4 as shown in Figure 56. (The RF3 and RF4 cables should have already been secured at location 1 in step n).

p. Gently tilt the antenna reflector up and down to ensure enough cable slack is present to allow unhindered vertical travel.

Figure 55 RF2 to "RF2 FROM IRD" Connector and Tie-Wraps

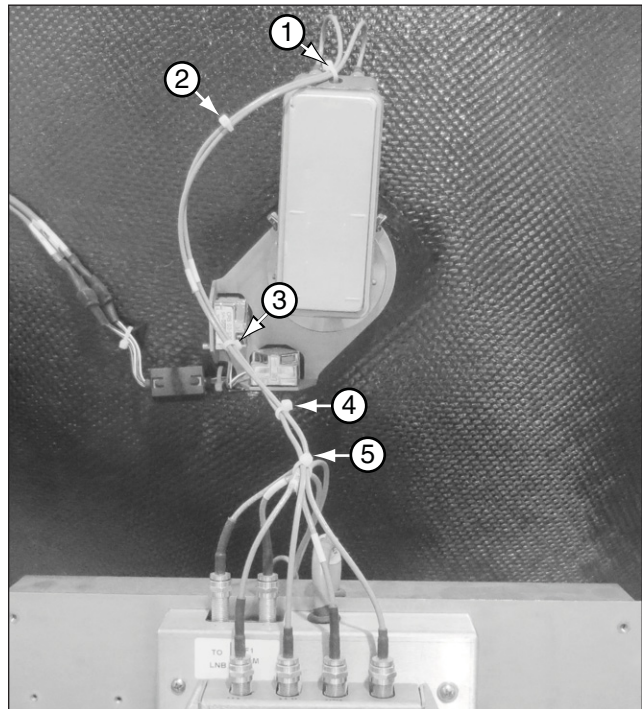
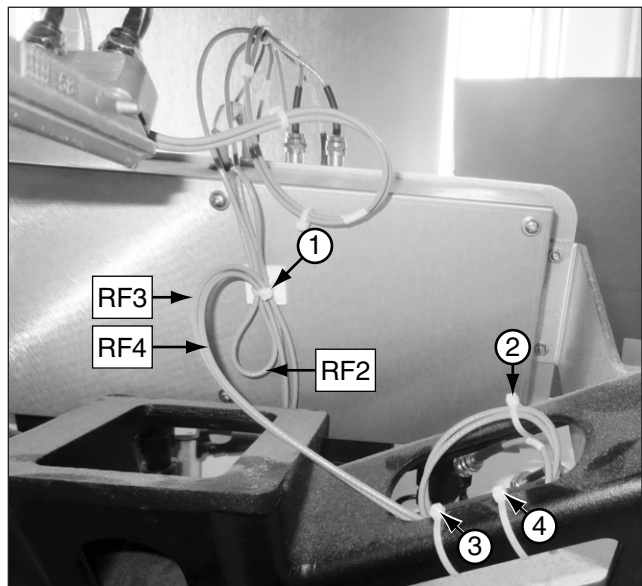

Figure 56 RF2, RF3, and RF4 Cable Loops and Tie-wraps



## Step 10 - Install the New Circular LNB (An Inverter PCB Was Not Installed/Modified)

The following instructions explain how to install a circular LNB. **Only perform this procedure if indicated in Table 1: LNB Conversion Matrix on page 3.**

- a. Reconnect power to the TracVision system. Then connect a PC to the TracVision system.

*NOTE: Connection instructions vary. Refer to the Flash Update Wizard's Help file for connection instructions (see Figure 57).*

- b. Open the Flash Update Wizard. Then turn on the TracVision system. Wait two minutes for system startup.
- c. Type the following commands into the wizard's "Command" box. Press Enter after each command.

**HALT  
DEBUGON  
SKEWMTROFF  
ZAP**

### **IMPORTANT!**

Failure to enter these antenna commands can cause serious damage to the antenna.

- d. The antenna will restart. Wait two minutes for system startup.
- e. Disconnect power from the TracVision system and any connected receivers and/or multiswitch.
- f. Disconnect the RF1 and RF2 cables from the original LNB and connect the RF cables to the corresponding connectors on the new LNB (see Figure 58).
- g. If the original LNB is a quad-output linear LNB, disconnect the RF3, and RF4 cables from the quad-output linear LNB. Then apply connector caps on the ends of the cables (see Figure 59).

Figure 57 Flash Update Wizard Help

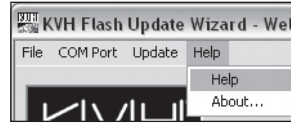

Figure 58 LNB Cable Connections

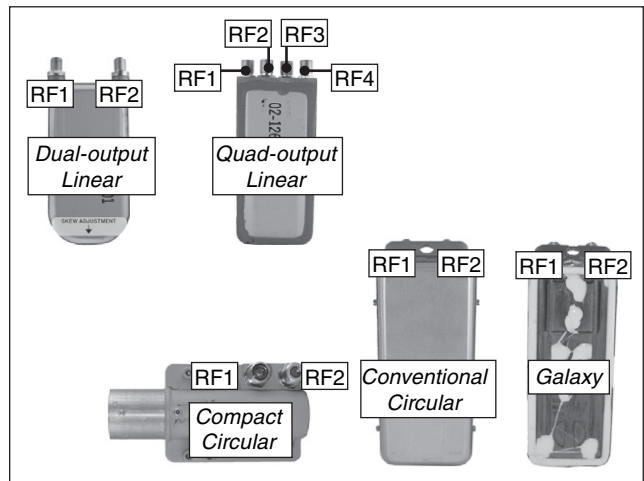
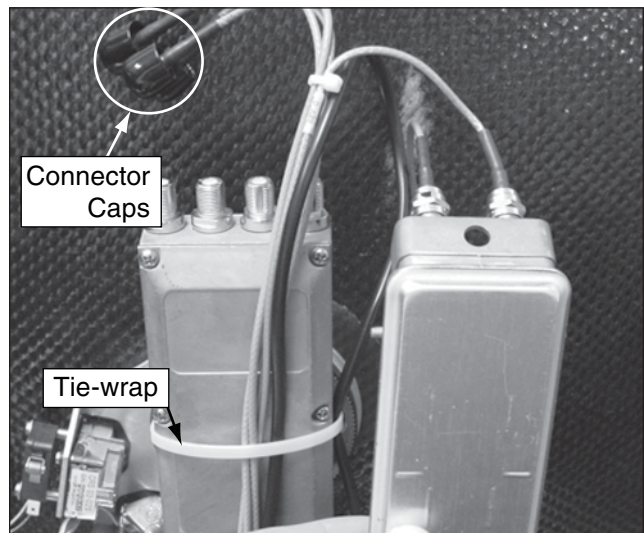

Figure 59 RF Cables/Connector Caps/Tie-wrap



- h. If a tie-wrap is securing the skew motor cable and cable bundle to the LNB, cut and remove the tie-wrap (see Figure 59 on page 27).
- i. Using a 5/64" hex key, loosen the two hex screws securing the LNB to the choke feed (see Figure 60).

*NOTE: Some antennas use wing screws instead of hex screws to secure the LNB to the choke feed.*

- j. Remove the original LNB and store it in a safe place.
- k. Insert the new LNB fully into the choke feed. Then tighten the two hex screws on the choke feed to secure the LNB in place (see Figure 60).
- l. **If the new LNB is a Galaxy LNB or a conventional circular LNB**, secure the skew motor cable to the LNB using a large tie-wrap, as shown in Figure 61.

*NOTE: Be sure to position the tie-wrap and the skew motor cable as shown in Figure 61.*

Figure 60 Choke Feed Screws

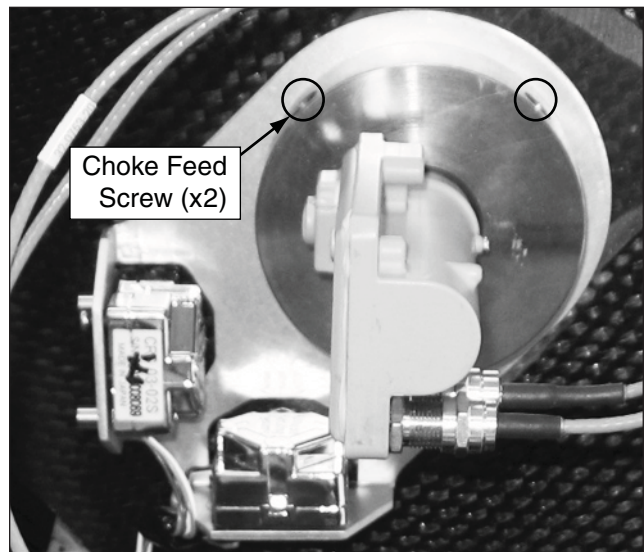
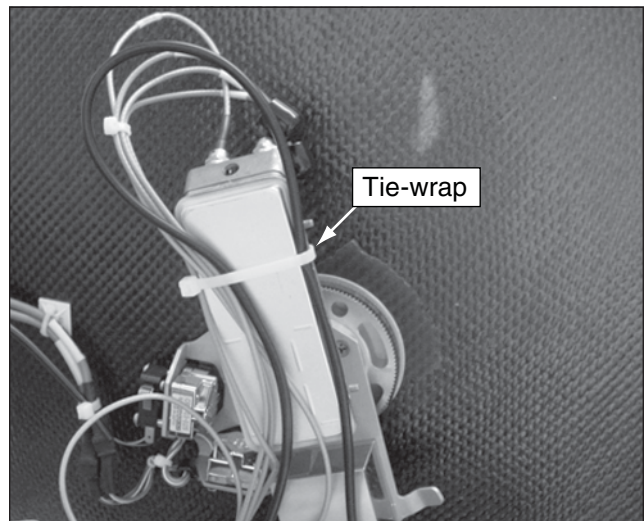

Figure 61 Galaxy/Conventional Circular LNB Tie-wrap Location



- m. If the new LNB is a compact circular LNB, secure the RF cables using three tie-wraps, as shown in Figure 62.
- n. Create a cable loop to eliminate excess slack in the unused RF cables that you disconnected from the original LNB. Then secure the RF cables with a tie-wrap to the PCB module (see Figure 63).
- o. Gently tilt the antenna reflector up and down to ensure enough cable slack is present to allow unhindered vertical travel.

### Step 11 - Install New Satellites

The TracVision M9 system must now be set to track new satellite(s) due to the LNB change. Follow the instructions provided in the TracVision M9 User's Guide to set the system to track the satellites of your choice.

The process is complete!

Figure 62 Compact Circular Tie-wrap Locations

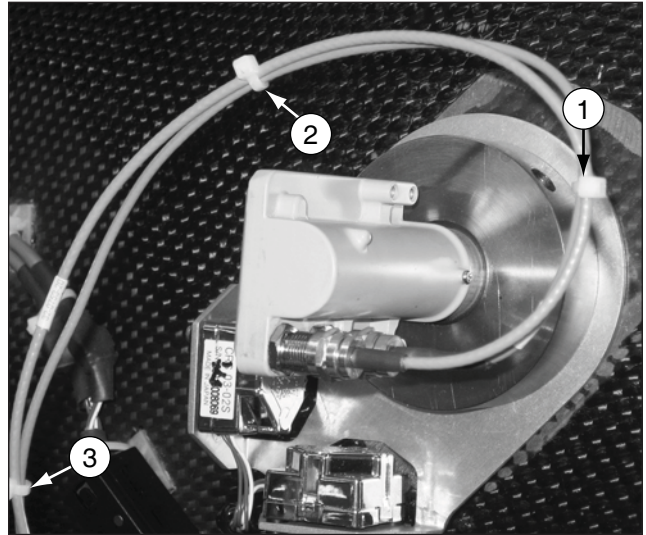

Figure 63 Excess Cable

