

TracVision® R5SL/R4SL Installation Guide

These instructions explain how to install the TracVision R5SL/R4SL on an RV or motor coach. Complete instructions on how to use the system are provided in the *User's Guide*.

Installation Steps

- | | | | |
|--------------------------------------|---|-------------------------------------|----|
| 1. Inspect Parts and Get Tools | 3 | 8. Wire the Receiver(s) | 10 |
| 2. Plan the Installation..... | 4 | 9. Ground the System..... | 11 |
| 3. Remove the Restraints | 5 | 10. Wire the Switchplate | 12 |
| 4. Mount the Antenna | 6 | 11. Install Service Key(s)..... | 13 |
| 5. Cut Out the Switchplate Hole..... | 7 | 12. Mount the Switchplate..... | 14 |
| 6. Wire the Antenna | 8 | 13. Set Up and Test the System..... | 15 |
| 7. Seal the Cable Access Hole..... | 9 | 14. Educate the Customer..... | 16 |

Who Should Install the System?

To ensure a safe and effective installation, KVH recommends that a KVH-authorized technician install the TracVision R5SL/R4SL system. To find a technician near you, please visit www.kvh.com/wheretogetservice. If you purchased the product and decide to install it yourself, please see the enclosed warranty statement for warranty implications.

Related Documentation

The following additional documents are provided with the TracVision R5SL/R4SL system:

Document	Description
User's Guide	Operation, setup, and troubleshooting information
Product Registration Form	Details on registering the product with KVH
Warranty Statement	Warranty terms and conditions
Contents List	List of every part supplied in the kit

Technical Support

If you need technical assistance, please contact KVH Technical Support:

Phone: +1 401 847-3327

E-mail: techs@kvh.com

(Mon.-Fri., 9 am-6 pm ET; Sat. 9 am-2 pm ET)

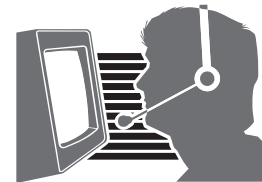

1 Inspect Parts and Get Tools

Before you begin, follow these steps to make sure you have everything you need to complete the installation.

IMPORTANT!

Always lift the antenna by the baseplate, never by the radome (see Figure 1).

- a. Unpack the box and ensure it contains everything shown on the supplied Contents List. Cables are stored beneath the antenna unit during shipping.
- b. Carefully examine all of the supplied parts to ensure nothing was damaged in shipment.
- c. Gather all of the tools and materials listed below. You will need these items to complete the installation.
 - Electric drill
 - 3/16" (5 mm), 5/32" (4 mm), and 3/32" (2.5 mm) drill bits
 - 3/4" (19 mm) hole saw and auger bit
 - Phillips and flat-head screwdrivers
 - Cutting pliers
 - RG-6 or RG-11 (75 ohms) RF cable, if installing two or more receivers
 - Silicone sealant, RTV, or equivalent
 - 7/16" open-end wrench
 - Construction adhesive suitable for the roof
 - Fasteners suitable for mounting the antenna to the roof
 - Augat IT1000 connector installation tool (KVH part #19-0242)
 - Satellite TV receiver(s) for your desired service (see Figure 2 for a list of validated receivers; for information on connecting different receiver models, contact KVH Technical Support at 401-847-3327)

Figure 1: TracVision R5SL/R4SL Antenna

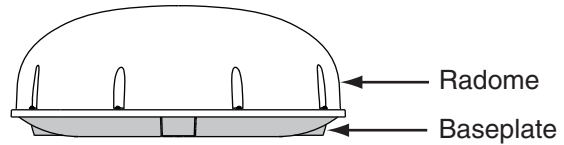

Figure 2: Receivers Validated for Use with TracVision R5SL/R4SL

Standard-definition models		
DIRECTV	DISH	Bell TV
D12	311	3100
D11	211k	4100
D10	211	
High-definition models		
DIRECTV	DISH	Bell TV
HD not supported	211k 211	6100 6131

2 Plan the Installation

Before you begin, consider the following installation guidelines:

- Minimize blockage. The antenna requires a clear view of the southern sky to receive satellite TV. Use the guidelines in Figure 3 to mount the antenna a suitable distance away from obstructions on the roof, such as air conditioners.
- Ensure the mounting surface is flat and strong enough to support the antenna's weight (28 lbs).

IMPORTANT!

When placed on the mounting surface, all three mounting plates must lay flat against the roof (within 7/16") to avoid warping the base and damaging the antenna.

- Select an antenna mounting location on the centerline of the vehicle with the antenna's cable connectors facing the rear of the vehicle (see Figure 4).
- Identify a safe location for the 3/4" (19 mm) cable access hole in the roof. The cable access hole should be located at least 6" (15 cm) away from the antenna's baseplate connectors (see Figure 4). Make sure you will not drill into any existing wires or aesthetic structures inside the vehicle.
- Choose a dry, flat location for the switchplate that will be easily accessible to the user. Take into account the 28-foot length of the power/data cable that connects from the antenna to the switchplate, the power supply's six-foot power cord, as well as accessibility to the equipment after installation.

NOTE: If you need a longer power/data cable, KVH offers 45-foot (KVH part #32-0730-45) and 60-foot (KVH part #32-0730-60) cables.

- Identify a location for the grounding block within 27 feet of the antenna, within 5 feet of the receiver(s), and within 25 feet of a suitable chassis ground location.

Figure 3: Blockage from Obstruction

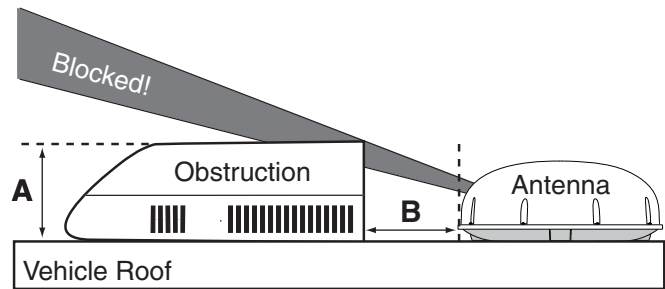

Obstruction Height (A)	Min. Distance from Antenna (B)
8"	6"
10"	12"
12"	17"
14"	23"
16"	28"

Figure 4: Antenna Orientation

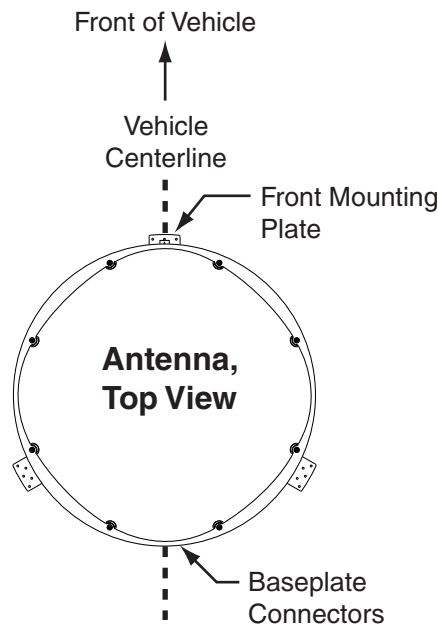

3 Remove the Restraints

At the bottom of the antenna, two tie-wraps prevent the internal antenna assembly from moving during shipment. Follow the steps below to remove these shipping restraints.

- a. Carefully carry the antenna to the roof of the vehicle.
- b. Using cutting pliers, cut and remove the two tie-wrap shipping restraints, located on the bottom of the antenna's baseplate (see Figure 5). **You do not need to remove the radome.**

IMPORTANT!

Once you have removed the restraints, keep the antenna level as much as possible and handle the antenna unit carefully. Improper handling might damage the unit.

- c. After removing the tie-wraps, seal the four tie-wrap holes and two additional holes in the bottom of the baseplate with the plugs provided in the kitpack (see Figure 6).

Figure 5: Removing the Shipping Restraints



Figure 6: Hole Locations

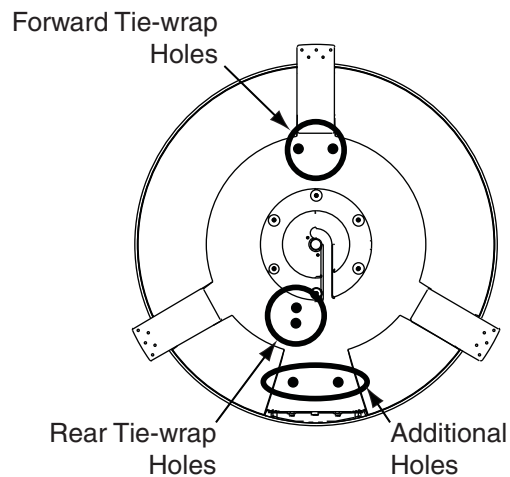

4 Mount the Antenna

Follow the steps below to mount the antenna to the vehicle's roof.

- a. Apply appropriate construction adhesive to the bottom of the antenna's three mounting plates across all of the holes.
- b. At the mounting location you chose in [“Plan the Installation”](#) on page 4, place the antenna on the centerline of the roof, so that the arrow on the antenna's front mounting plate points towards the front of the vehicle (see Figure 7).
- c. Attach the three antenna mounting plates to the roof using 15 fasteners appropriate for the roof's construction (see Figure 8).

IMPORTANT!

Due to the variation in RV roof construction, consult with the RV manufacturer to determine the safest fastening method.

- d. Seal all fasteners with silicone sealant or equivalent (see Figure 9).

Figure 7: Antenna Orientation

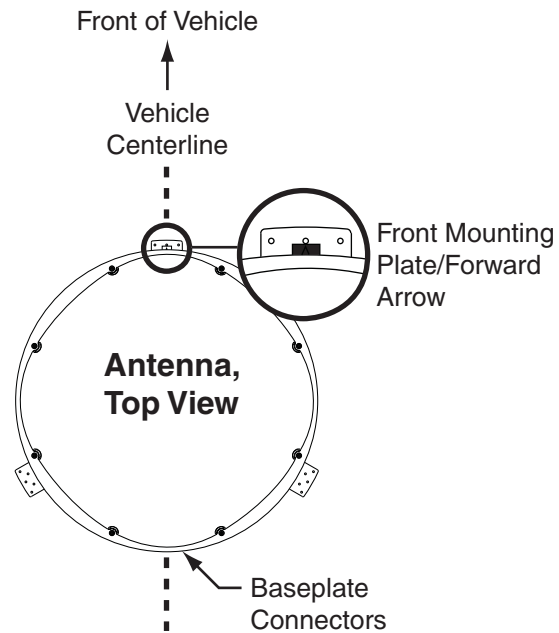

Figure 8: Attaching the Mounting Plates

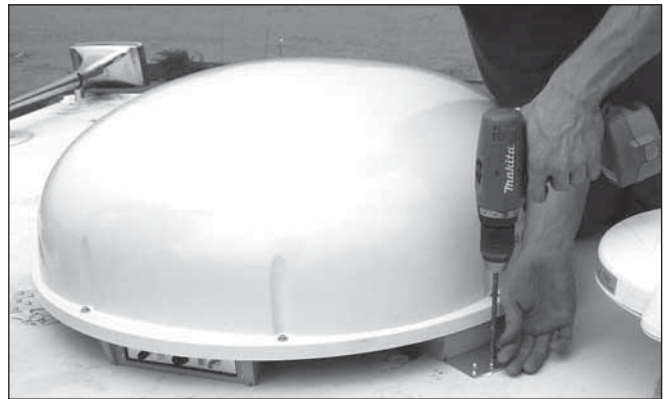

Figure 9: Sealing the Fasteners



5 Cut Out the Switchplate Hole

Follow the steps below to cut out the switchplate mounting hole.

- Using the switchplate mounting template supplied in [Appendix C on page 21](#), mark and cut out a hole in the mounting surface to accommodate the switchplate (see Figure 10).
- Using the same template, mark the locations for the four switchplate mounting holes.
- Drill a $\frac{3}{32}$ " (2.25 mm) hole at the four mounting hole locations. Later, you will mount the switchplate using four #6 screws.

Figure 10: Switchplate Cutout Dimensions

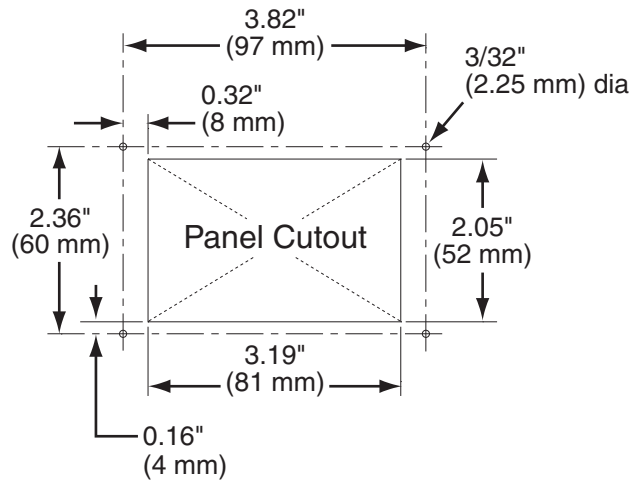

6 Wire the Antenna

Follow the steps below to wire the antenna.

- a. At the location you chose in “Plan the Installation” on page 4, use a 3/4" (19 mm) hole saw to cut out a cable access hole in the vehicle’s roof (see Figure 11).
- b. Smooth the edges of the hole to protect the cables.
- c. If you plan to connect multiple receivers, label both ends of two RF cables for later reference. Label one cable “RF1” and the other “RF2.”
- d. Route the power/data cable and the RF cable(s) down through the cable access hole in the roof. Be sure to maintain a service loop on the roof (approximately 8" (20 cm)).

NOTE: Ensure the rubber sealing boot on the RF cable is located on the end of the cable closest to the antenna’s baseplate connectors.

- e. Connect an RF cable to the antenna’s “RF1” connector. Hand-tighten first, then tighten with a 7/16" wrench for 1/4 turn.

NOTE: Leave the protective cap installed on the RF2 connector unless you are connecting a second RF cable.

- f. If you plan to connect multiple receivers, connect a second RF cable to the “RF2” connector.
- g. Connect the power/data cable to the antenna’s center connector and lock in place (see Figure 12).
- h. Slide the rubber sealing boot up the RF cable until it covers the connector. This boot will help protect the connector from the elements.

Figure 11: Drilling the Cable Access Hole



Figure 12: Wiring the Antenna

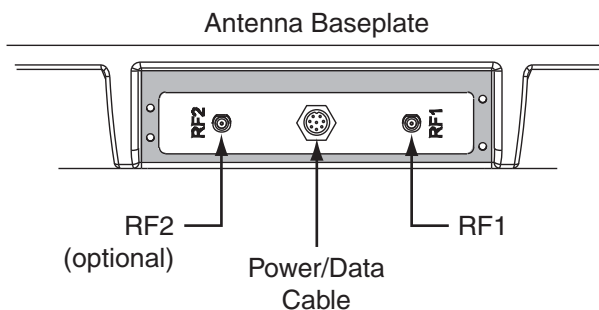

7 Seal the Cable Access Hole

Follow the steps below to seal the cable access hole.

- a. Seal the cable access hole on the roof with a liberal amount of silicone sealant, RTV, or equivalent to protect against leakage.
- b. Install the clamshell ventilator, supplied in the kitpack, over the cable access hole using three of the supplied #6 screws (see Figure 13).
- c. Route the RF cable(s) to the grounding block location you chose in [“Plan the Installation” on page 4](#).
- d. Route the power/data cable through the switchplate cutout you made in [“Cut Out the Switchplate Hole” on page 7](#).

Figure 13: Installing the Clamshell Ventilator

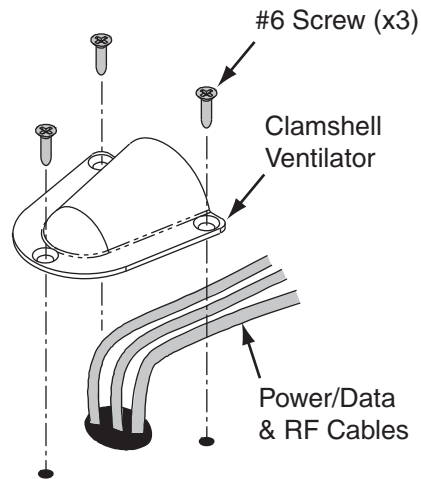

8 Wire the Receiver(s)

Follow the steps below to wire your receiver(s).

IMPORTANT!

If you cut the RF cable(s) or used additional RF cabling, be sure to terminate all RF cables with Snap-N-Seal® F-connectors using an Augat IT1000 connector installation tool (KVH part #19-0242). Screw-on, push-on, twist-on, and other low-quality connectors will degrade system performance.

- a. Connect the RF1 cable from the antenna to the grounding block, as shown in Figure 15. Label this grounding block connector “RF1.”
- b. If you connected an RF2 cable in “Wire the Antenna” on page 8, connect the RF2 cable from the antenna to the grounding block. Label this connector “RF2.”

NOTE: If you need to connect three or more receivers, refer to [Appendix A on page 19](#).

- c. If you are connecting two receivers to the TracVision system, decide which receiver will be the primary receiver. The primary receiver controls satellite selection.

NOTE: Unless a KVH Master Receiver Selector is installed, the secondary receiver will only be able to select channels carried on the satellite that is currently selected by the primary receiver.

- d. Connect the supplied 5-foot RF cable from the “RF1” connector on the grounding block to the “Satellite In” connector on the primary receiver (see Figure 15).
- e. If you are connecting a second receiver, connect an RF cable from the “RF2” connector on the grounding block to the “Satellite In” connector on the secondary receiver.
- f. Connect the receiver(s) to the customer’s television(s). Follow the instructions in the receiver’s manual.

Figure 14: Augat IT1000 Connector Installation Tool

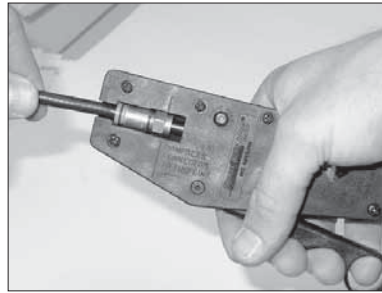
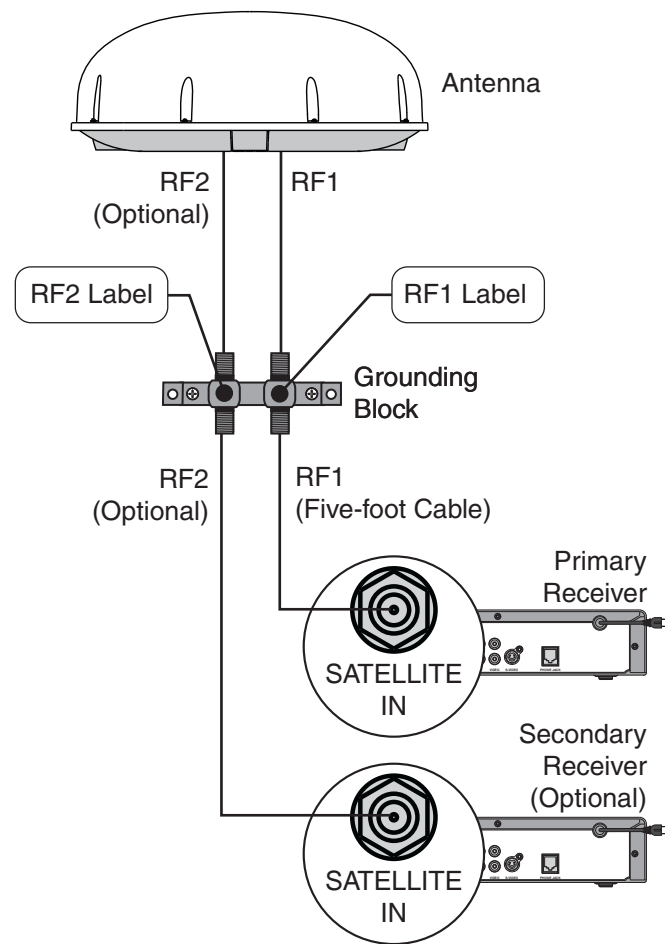

Figure 15: Grounding Block and Receiver Wiring



9 Ground the System

To ensure proper operation, follow the steps below to ground your TracVision system.

- a. Attach the supplied ground wire to either grounding screw on the grounding block (see Figure 16). Connect the other end of the wire to a suitable vehicle AC ground.
- b. Using the two #6 screws supplied with the grounding block, mount the grounding block at the location you chose in [“Plan the Installation”](#) on page 4.

Figure 16: Grounding Block Mounting and Grounding

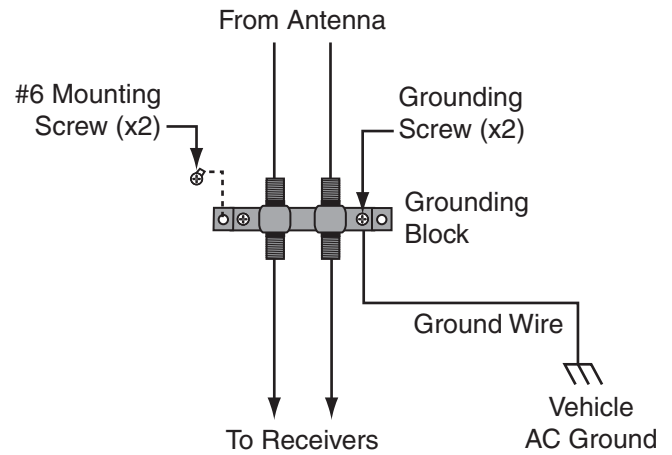

10 Wire the Switchplate

Follow the steps below to wire the switchplate.



CAUTION

For your own safety, shut down vehicle power before you connect wires. Test the circuit to ensure no power is present.

- a. Connect the antenna's power/data cable to the switchplate's power/data connector and lock in place (see Figure 17).
- b. Crimp the supplied terminal connectors onto the 15 VDC power supply's DC power wires.
- c. Carefully push the connectors onto the switchplate's input power terminals (see Figure 17).

NOTE: Strain-relieve the wires to ensure a reliable connection.

- d. Connect the AC power cord to the power supply. Then plug the power cord into the vehicle's AC power.

Figure 17: Switchplate Wiring

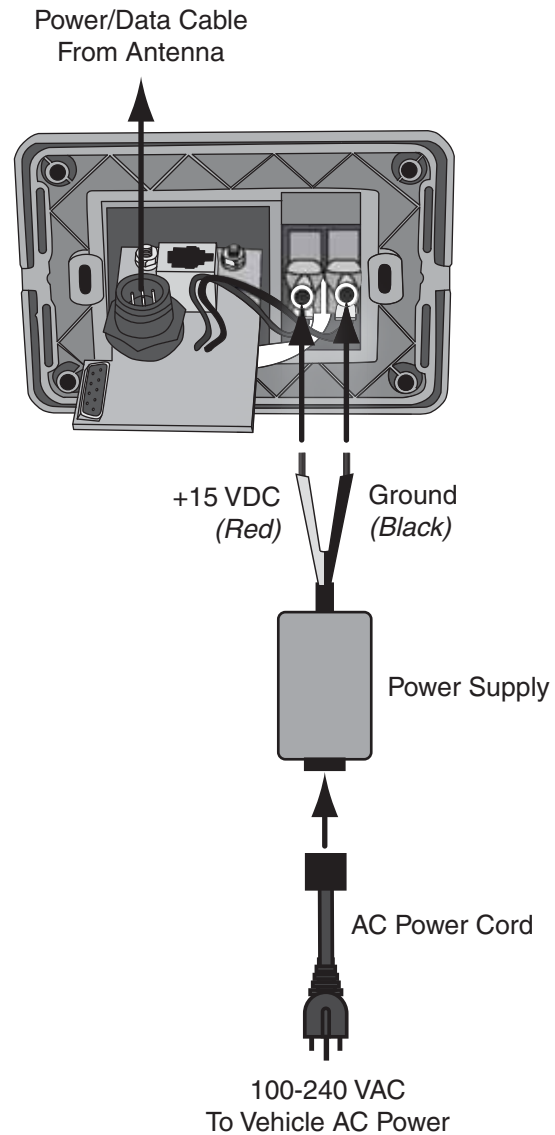

11 Install Service Key(s)

Find your satellite TV service below to determine which service key(s), if any, you need to install. Store any unused service keys in the TracVision system's Welcome Kit.

DIRECTV

The system is already set up from the factory for DIRECTV service. No service keys are required to track the DIRECTV 101 and 119 satellites.

DISH Network

Choose from among three DISH Network modes:

Mode	Satellites
DISH 1000/129*	110, 119, and 129
DISH 1000/61	110, 119, and 61
DISH 500	110 and 119

* Optional Master Receiver Selector (KVH part #72-0412) required for automatic satellite switching while the vehicle is in motion (R5SL).

Select a DISH 1000 mode for DISH Network's TurboHD service. Use the map in Figure 18 to determine the best mode for your region. Check with DISH Network regarding local channels.

DISH 1000/129

No service keys are required.

DISH 1000/61

Connect service key "A" to the front of the switchplate (see Figure 20).

DISH 500

Connect both service keys to the switchplate (see Figure 20 and Figure 21).

Bell TV (Formerly ExpressVu)

Connect service key "B" to the back of the switchplate to set up the system to track the Bell TV 91 and 82 satellites (see Figure 21).

NOTE: If you wish to set up the system to track satellites not listed above, do not connect any service keys. Refer to [Appendix B on page 20](#).

If Necessary - See Below

Figure 18: Recommended DISH 1000 Satellites

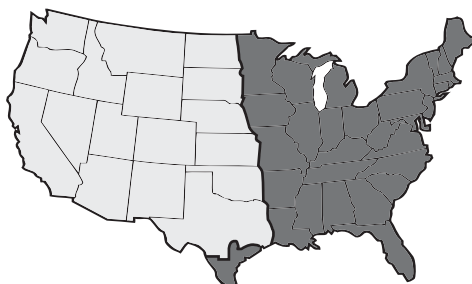

- = DISH 129 Satellite Recommended
- = DISH 61 Satellite Recommended

Figure 19: Service Keys Usage

Mode	Key A	Key B
DISH 1000/129	-	-
DISH 1000/61	Connect	-
DISH 500	Connect	Connect
Bell TV	-	Connect

Figure 20: Connecting Service Key A (Front of Switchplate)

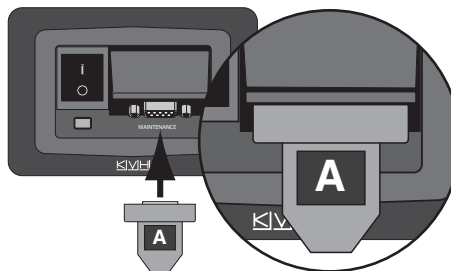
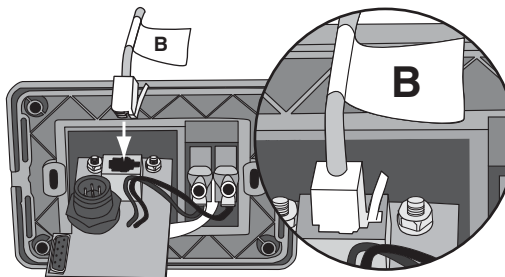

Figure 21: Connecting Service Key B (Back of Switchplate)



12 Mount the Switchplate

Follow the steps below to mount the switchplate.

- a. Fit the switchplate flush into the panel cutout you made in [“Cut Out the Switchplate Hole” on page 7](#).
- b. Drill out four $5/32$ " (4 mm) mounting holes in the switchplate's screw cavities (see Figure 22).
- c. Mount the switchplate to the mounting surface using four #6 screws.
- d. Gently snap the switchplate cover onto the front of the switchplate to conceal the mounting screws.

Figure 22: Switchplate Mounting

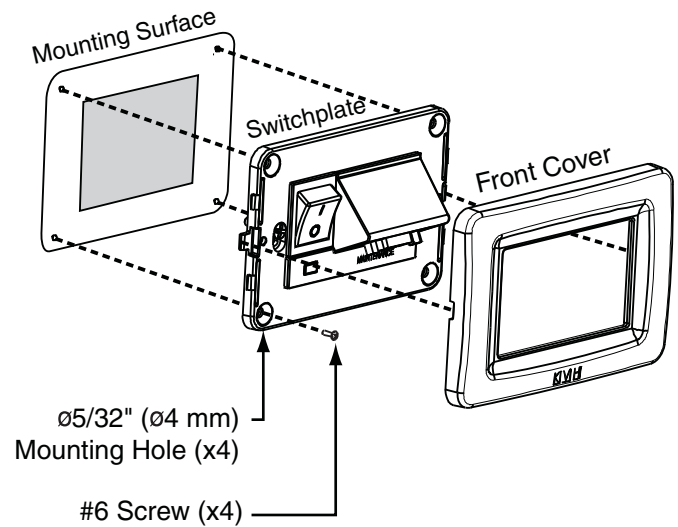

13 Set Up and Test the System

Follow the steps below to set up the system for your desired satellite TV service and test the system for proper operation.

- a. Park the vehicle in a blockage-free area. The antenna requires an unobstructed view of the southern sky to receive satellite signals.
- b. **DISH Network or Bell TV only:** Follow the step-by-step setup instructions provided in the *User's Guide* to configure your DISH Network or Bell TV receiver(s) for your selected TracVision mode.

IMPORTANT!

Each DISH Network or Bell TV receiver must be configured to work with the TracVision system, as explained in the *User's Guide*.

- c. Turn on the receiver(s) and TV(s). For details on operating the receiver, refer to your selected receiver's user manual.
- d. Set the switchplate's POWER switch to the ON (|) position (see Figure 23). Within a few minutes, a picture should appear on the TV.
- e. **TracVision R5SL only** - Take a road test to verify the antenna tracks the satellite while the vehicle is moving.
- f. When you have finished testing, set the switchplate's POWER switch to the OFF (O) position. Be sure to leave the Welcome Kit inside the vehicle for the customer, and place any unused service keys inside the kit.

Figure 23: Switchplate ON/OFF Switch

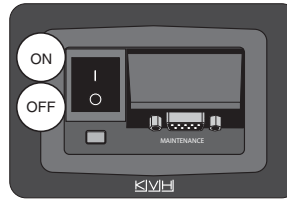

14 Educate the Customer

Give the Welcome Kit to the customer and explain how to use the product. Also be sure the customer understands the following:

- The receiver(s) must be activated before it can decode satellite TV signals (see Figure 24).
- The antenna must have a clear view of the southern sky to receive satellite TV. Common causes of blockage include trees, buildings, overpasses, and mountains (see Figure 25). The system will not work inside a garage.
- Keep the radome installed on the antenna at all times. The radome protects the antenna's moving parts from wind, rain, and debris.
- Heavy rain or snow might temporarily interrupt satellite reception.
- Clean the antenna periodically. Dirt buildup can affect satellite TV reception.
- **(DISH 1000 modes)** You may need to change the operating mode when traveling between regions (see “Install Service Key(s)” on page 13).
- **(DISH 1000/129 mode)** If you don't have a Master Receiver Selector installed, DISH 1000/129 mode is limited to stationary use only. Also, before you turn on the antenna, you must first select satellite 119 and transponder 17 at the receiver's “Point Dish/Signal Strength” screen (press MENU, 6, 1, 1).
- Please register the system with KVH. The registration process is quick, easy, online, and ensures the best possible service from KVH. Visit www.kvh.com/register or refer to the Product Registration Form for details.
- The vehicle must be located within the selected satellite's footprint in order to receive its signals. To view satellite coverage maps, visit www.kvh.com/footprint.
- If you need to paint the radome, use only non-metallic automotive paint without a primer coat. Paint containing metal will block satellite signals and impair reception.
- Refer to the *User's Guide* for complete operation and troubleshooting information.

Figure 24: Receiver Activation

Service:	Call to Activate:
DIRECTV	1-866-551-8004 (24 hours, 7 days a week)
DISH Network	1-866-399-8509 (Mon.-Fri., 8:30am - 5pm ET)
Bell TV	1-888-759-3474 (SKY-DISH) (24 hours, 7 days a week)

Figure 25: Blockage Example

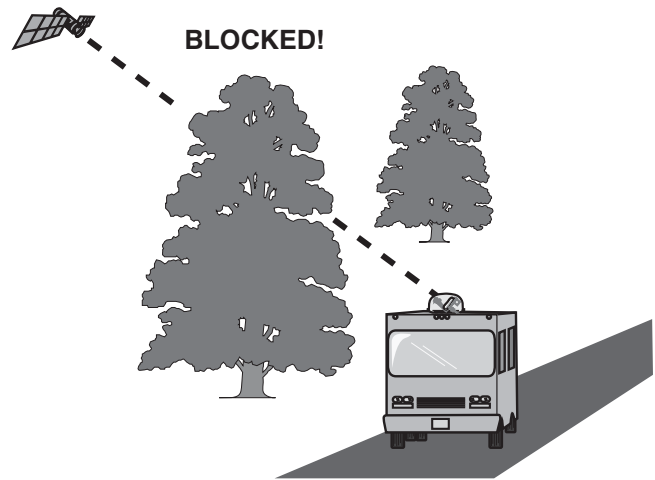

Appendices

This section includes the switchplate mounting template and provides supplemental instructions for special or advanced configurations.

Contents

- A. [Connecting 3 or More Receivers](#) 19
- B. [Choosing Alternate Satellites](#)..... 20
- C. [Switchplate Template](#) 21

A Connecting 3 or More Receivers

If you need to connect three or more receivers, install an active (powered) multiswitch or Master Receiver Selector between the grounding block and the receivers, as shown in Figure A-1.

NOTE: If you need to connect more than four receivers, please contact KVH Technical Support.

Active Multiswitch

The optional Eagle Aspen multiswitch with AC/DC power supply (KVH part #72-0310) allows you to connect three or four receivers to the TracVision system. However, since a multiswitch interrupts satellite switching communications between the receiver and the antenna, you will need to manually switch between your selected satellites.

With the TV/SAT Switch (KVH part #01-0245) installed, you can manually switch between a pair of satellites at the press of a single button. For alternative manual switching options, such as typing switch commands via a PC, please contact KVH Technical Support.

IMPORTANT!

The TV/SAT Switch only supports dual-satellite configurations, so it cannot be used with three-satellite DISH 1000 modes. If you need to connect three or more receivers in a DISH 1000 mode, the best option is the Master Receiver Selector (see below).

Master Receiver Selector

The optional KVH Master Receiver Selector (KVH part #72-0412) is an enhanced multiswitch that provides the following capabilities:

- Automatic satellite switching in any operating mode, including DISH 1000/129.
- (R5SL only) In-motion operation in any mode, including DISH 1000/129.
- Support for three or more receivers.
- Capability for the user to select, at any time, which receiver controls satellite selection. Simply turn the knob!

Figure A-1: Wiring 3 or 4 Receivers

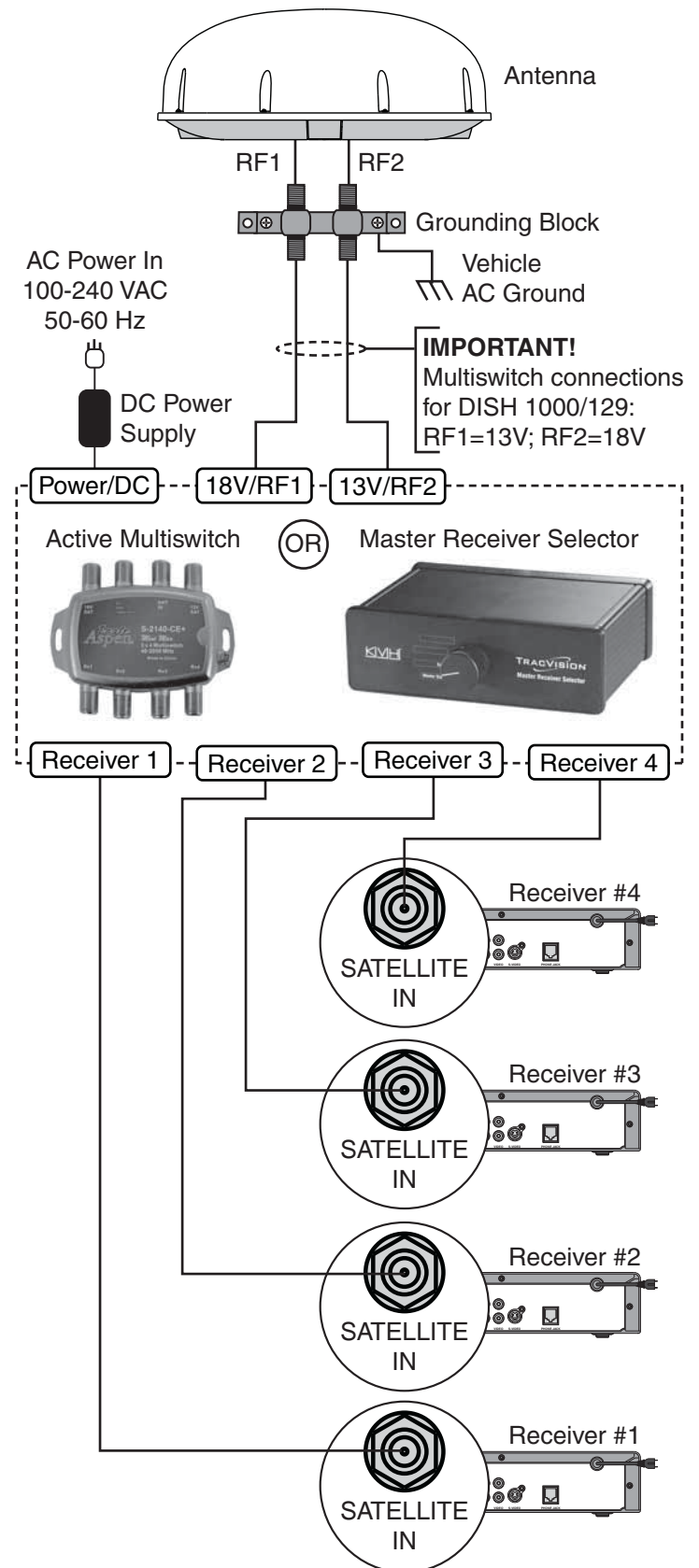

B Choosing Alternate Satellites

Although most installations do not require different satellites than those listed in “Install Service Key(s)” on page 13, you may set up your TracVision R5SL/R4SL to track a pair of alternate satellites.

To do so, you need to connect a PC to the antenna and use the KVH Flash Update Wizard to install your alternate satellites. The TracVision R5SL/R4SL system includes a satellite library that contains the most commonly used satellites. Follow the steps below to configure the system to track satellites from this satellite library.

NOTE: The Flash Update Wizard is available to KVH-authorized dealers through the KVH Partner Portal.

- a. Connect a PC to your TracVision system, as described in the Flash Update Wizard’s Help file. Then enter the commands below into the Wizard’s “Antenna Comms” window.

NOTE: For details on entering antenna commands, refer to the Flash Update Wizard’s Help file.

- b. Type **HALT** then press Enter.
- c. Choose your desired satellites from the satellite library (see Figure B-1).
- d. Type the following command then press Enter. Be sure to use the proper install name(s) for your selected satellite(s).

**SATINSTALL,<SAT_A_NAME>,
<SAT_B_NAME>**

NOTE: Select the satellite you want to track first as “SAT_A”. Once the procedure is complete, the TracVision R5SL/R4SL system will begin tracking that satellite.

- e. Type **ZAP** then press Enter to restart the antenna. Wait two minutes for system startup.

Figure B-1: TracVision Satellite Library

Service	Satellite	Install Name
DIRECTV	72° W	DSS_72
	101° W	DSS_101
	110° W	DSS_110
	119° W	DSS_119
DISH Network	61° W	ECHO_61
	110° W	ECHO_110
	119° W	ECHO_119
	129° W*	ECHO_129
Bell TV (ExpressVu)	82° W	EXPRESSVU
	91° W	EXPRESSTV
None	-	NONE

* KVH Master Receiver Selector (KVH part #72-0412) required for DISH Network’s 129 satellite.

Figure B-2: Example of Choosing an Alternate Satellite

Installing DISH Network 119° W Only
HALT SATINSTALL,ECHO_119,NONE ZAP



Switchplate Template

