

KVH Industries, Inc.

TracVision® M5/M7

Control Panel Configuration



User's Guide

PLEASE READ!

Important Addendum to the Product Manuals

This addendum applies to systems having the following serial number or later:

M5: 131000890

M7: 131000307

Your TracVision[®] M5/M7 antenna is equipped with a new RF7 board, which expands the satellite tracking capabilities of the system.

Supported Decoding Types

In addition to legacy QPSK DSS and DVB satellite signals, the RF7 board adds the capability to decode the following types of signals:

- Turbo QPSK (DISH DVB-S2)
- QPSK DCII (DigiCipher 2)
- Turbo 8PSK (DISH DVB-S2)
- LDPC 8PSK (standard DVB-S2)
- LDPC QPSK (standard DVB-S2)

The procedure for configuring user-defined satellites has been updated to include these new decoding types. Refer to the attached application note for details.

Supported FEC Codes

The RF7 board adds the capability to decode satellite signals that use the following FEC (forward error correction) codes:

- 3/5
- 4/5
- 8/9
- 5/11
- 9/10

The procedure for configuring user-defined satellites has been updated to include these new FEC codes. Refer to the attached application note for details.

NOTE: The RF7 board also continues to support the following FEC codes: 1/2, 2/3, 3/4, 5/6, 6/7, 7/8, and 99 (auto).

Signal Quality

The RF7 board now reports SNR (signal-to-noise ratio) rather than BER (bit error rate) to indicate the quality of the received satellite signal.

Control Panel Configuration: To view the SNR on the MCP front panel, select *Operations Mode > Get Antenna Status > Get SNR*.

GyroTrac Configuration: To view the SNR on the ADCU, select *Get Antenna Status > Get SNR*.

Switchplate Configuration: To view the SNR on your laptop connected to the antenna, enter the **@SNR** command in either HyperTerminal or the Flash Update Wizard.

Satellite Library

The following satellites have been added to the RF7 board's satellite library:

Satellite Name	Satellite Position	Installation Name	LNB Type
Astra 3	23.5° E	ASTRA3	Linear

The following satellite data have been updated in the RF7 board's satellite library:

Satellite Name	Satellite Position	Installation Name	LNB Type
Optus D1	160.0° E	OPTUS_D1	Linear
Optus C1	156.0° E	OPTUS_C1	Linear

Configuring User-Defined Satellite(s)

To configure a user-defined satellite, you will need to enter satellite tracking information into the antenna. This procedure requires a Windows-based PC with the most current version of the KVH Flash Update Wizard installed. You will use the Flash Update Wizard to enter the following information:

- Satellite name
- Satellite longitudinal position
- Transponder information for all applicable combinations of polarization/band:
 - Frequency
 - Symbol rate
 - FEC code
 - Network ID
- Decoding type

Circular satellites use the following polarizations:

- Left
- Right

Linear satellites use the following polarizations and bands:

- Vertical high (11700 – 12750 MHz)
- Vertical low (10700 – 11700 MHz)
- Horizontal high (11700 – 12750 MHz)
- Horizontal low (10700 – 11700 MHz)

NOTE: A 22 KHz tone must be present on the TracVision system's coaxial cable to enable switching to high band channels.

TIP: You can find satellite information on the web at www.lyngsat.com (not affiliated with KVH).

Step 1 – Connect Your PC to the TracVision System

Follow the instructions provided in the Flash Update Wizard's Help file to connect your PC to the TracVision system.

Step 2 – Define the Satellite(s)

Now you need to enter the following commands into the Flash Update Wizard's "Command Line" box.

NOTE: Variables are shown in *bold italics*.

1. Enter **HALT**.
2. Enter **DEBUGON**.
3. Using the table below, enter the following SATCONFIG command:

SATCONFIG,a,b,c,d,e

Field	Description
a	User-defined satellite stored in the antenna library: USER1 = User-defined Satellite 1 USER2 = User-defined Satellite 2
b	Longitude: 0-180
c	E (East) or W (West)
d	Decoding type: 0 = Turbo QPSK (DISH DVB-S2)* 1 = QPSK DCII (DigiCipher 2)* 2 = QPSK DTV (Legacy DSS) 3 = QPSK DVB (Legacy DVB) 4 = Turbo 8PSK (DISH DVB-S2)* 5 = LDPC 8PSK (Standard DVB-S2)* 6 = LDPC QPSK (Standard DVB-S2)*
e	Polarization: L = Linear C = Circular

* RF7 board required

Step 3 – Install the User-defined Satellite(s)

Follow the steps in the TracVision system's manual to select your new user-defined satellite(s) for tracking. Be sure to use the following installation names for your user-defined satellite(s):

Satellite	Installation Name
User-defined Satellite 1	USER1
User-defined Satellite 2	USER2

Step 4 – Configure the RF Tracking Parameters

Follow the steps below to set up the tracking parameters of the user-defined satellite(s).

1. Enter **@DEBUGON**.
2. Using the table below, enter the following **@SATCONFIG** command:

@SATCONFIG,a,b,c,d,e,f,g,h,i

Field	Description
a	User-defined satellite position stored in antenna library: A = satellite position A B = satellite position B
b	User-defined satellite stored in antenna library: 98 = User1 99 = User2
c	Frequency, MHz (00000 or 10700-12750)
d	Symbol rate, kilosymbols per second (10000-45000; 33000 max if DVB-S2)
e	FEC code: 12, 23, 34, 35*, 45*, 56, 67, 78, 89*, 51 (5/11)*, 91 (9/10)*, or 99 (auto)
f	Network ID, hexadecimal (0x####)
g	Polarization: V = Vertical H = Horizontal R = Right L = Left
h	LNB down conversion frequency: U = USA (DBS) (LO=11250 MHz) L = Low (LO=9750 MHz) H = High (LO=10600 MHz) G = Latin America (LO=10500 MHz) S = Sinosat (LO=11300 MHz)
i	Decoding type: 0 = Turbo QPSK (DISH DVB-S2)* 1 = QPSK DCII (DigiCipher 2)* 2 = QPSK DTV (Legacy DSS) 3 = QPSK DVB (Legacy DVB) 4 = Turbo 8PSK (DISH DVB-S2)* 5 = LDPC 8PSK (Standard DVB-S2)* 6 = LDPC QPSK (Standard DVB-S2)*

* RF7 board required



3. Repeat Step 2 for each applicable polarization/band shown below.

- Linear systems:
 - Vertical high
 - Vertical low
 - Horizontal high
 - Horizontal low
- Circular systems:
 - Right
 - Left

If your selected satellite does not have information for one or more of these transponder categories, you can enter the following default values instead:

Transponder Data	Default Value
Frequency	00000
Symbol rate	27500
FEC code	Same value as other transponders with valid data
Network ID	0x0000

4. Enter **ZAP**.
5. The antenna will restart. Wait two minutes for system startup.
6. Repeat this procedure if you wish to program a second user-defined satellite.

Example – Linear Satellite

The following is an example of programming the fictional “YOURSAT 7” as the USER1 user-defined satellite.

YOURSAT 7 AT 7°W, legacy DVB decoder, linear polarization

Transponder Data	Value
<i>Horizontal High</i>	
Frequency	11.966 GHz
Symbol rate	27500
FEC code	3/4
Network ID	2048 (dec) = 0x0800
<i>Vertical High</i>	
Frequency	11.823 GHz
Symbol rate	27500
FEC code	3/4
Network ID	2048 (dec) = 0x0800
<i>Vertical Low</i>	
No data listed	
<i>Horizontal Low</i>	
No data listed	

Based on the above information, you would enter the following commands:

```

HALT
DEBUGON
SATCONFIG,USER1,7,W,3,L
SATINSTALL,USER1,NONE
@DEBUGON
@SATCONFIG,A,98,11966,27500,34,0X0800,H,H,3
@SATCONFIG,A,98,11823,27500,34,0X0800,V,H,3
@SATCONFIG,A,98,00000,27500,34,0X0000,V,L,3
@SATCONFIG,A,98,00000,27500,34,0X0000,H,L,3
ZAP

```



Example – Circular Satellite

The following is an example of programming the fictional “YOURSAT 122” as the USER2 user-defined satellite.

YOURSAT 122 AT 122°W, standard DVB-S2 8PSK decoder, circular polarization

Transponder Data	Value
Right	
Frequency	12.225 GHz
Symbol rate	20000
FEC code	5/6
Network ID	4100 (dec) = 0x1004
Left	
Frequency	12.456 GHz
Symbol rate	20000
FEC code	5/6
Network ID	4100 (dec) = 0x1004

Based on the above information, you would enter the following commands:

```

HALT
DEBUGON
SATCONFIG,USER2,122,W,5,C
SATINSTALL,USER2,NONE
@DEBUGON
@SATCONFIG,A,99,12225,20000,56,0X1004,R,U,5
@SATCONFIG,A,99,12456,20000,56,0X1004,L,U,5
ZAP

```



Important Information About Your TracVision® M7 System with Auto Skew

Note: Not all TracVision M7 systems include Auto Skew. If you are unsure whether your linear TracVision M7 system includes automatic or manual skew adjustment, please refer to the documentation supplied with your system.

Congratulations! Your TracVision M7 system has Auto Skew capability, which provides automatic skew angle adjustment for your selected satellite(s), and an internal GPS antenna. These added features are not cited in the product manuals.

You Do Not Need to Adjust the LNB Skew Angle.

Your TracVision system includes an Auto Skew mechanism, which automatically adjusts the skew angle of the antenna's LNB. Therefore, disregard any instructions in the manuals that direct you to modify the LNB's skew angle. No manual adjustment is necessary.

TIP: For more information on how skew works, please refer to the TracVision M7 User's Guide.

You Do Not Need to Enter Your Latitude and Longitude.

Your TracVision M7 system includes a GPS antenna, which provides constantly updated location information to the TracVision system. Therefore, disregard any instructions in the manuals that direct you to manually enter the vessel's latitude and longitude.

MultiSat Control Panel Menu Quick Reference Guide

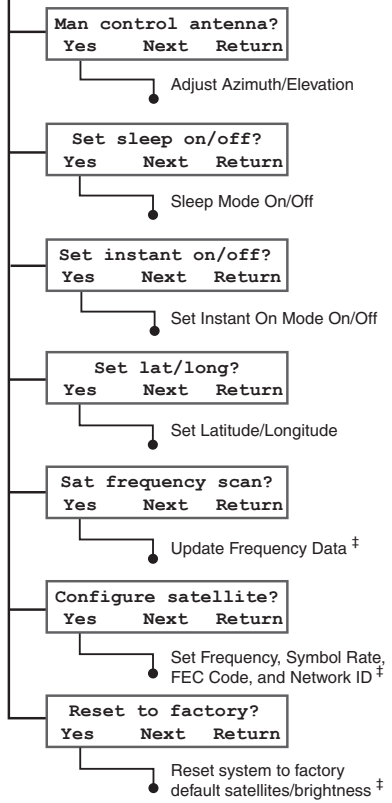
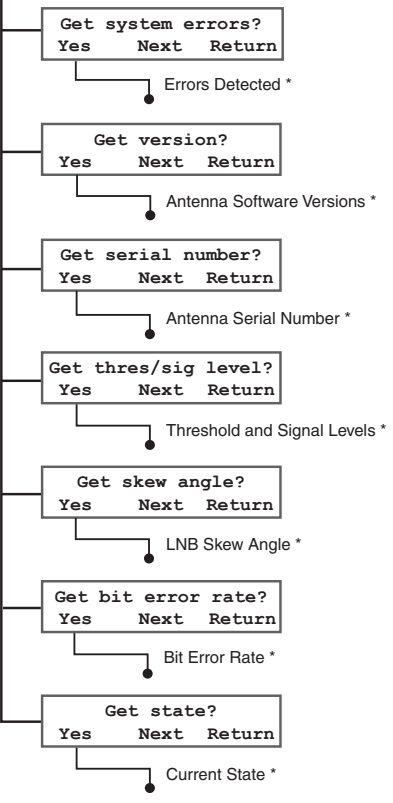
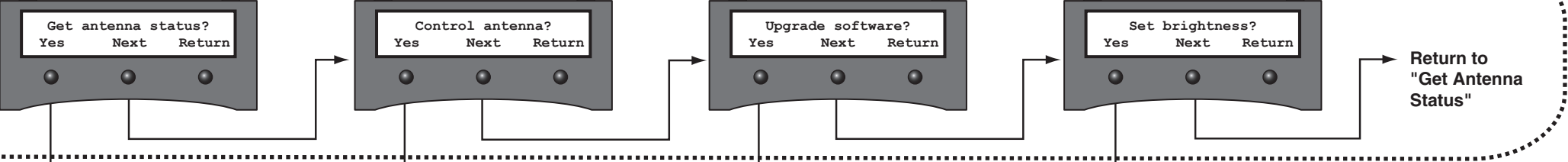
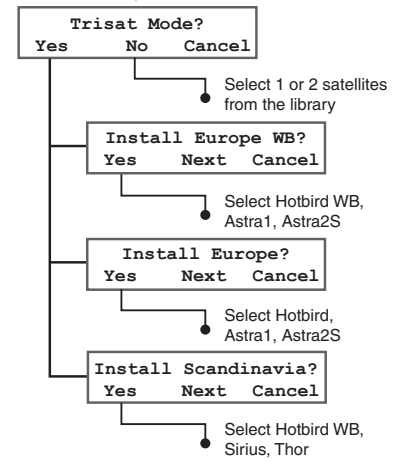
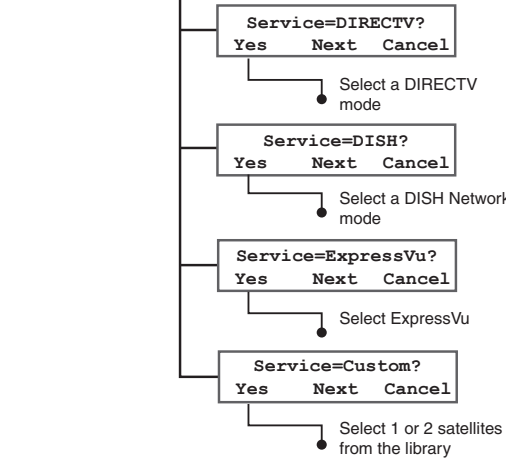
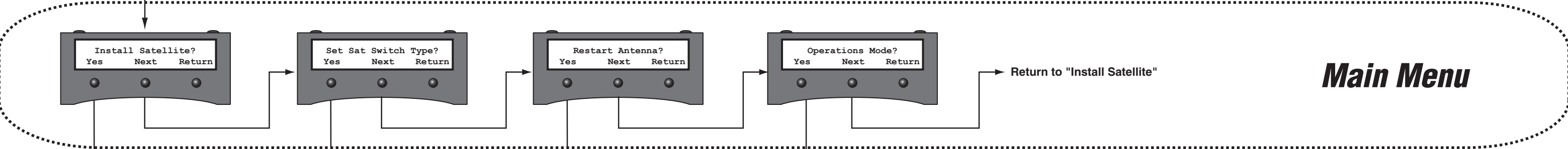

Use the latest version of the KVH Flash Update Wizard to upgrade the software

* Press any button to return

† TracVision M5/M7/M9 only

TracVision M5/M7

MultiSat Control Panel Configuration

User's Guide

This user's guide provides all of the basic information you need to operate, set up, and troubleshoot the TracVision M5/M7 satellite TV antenna system. For detailed installation information, please refer to the TracVision M5/M7 Installation Guide.



Please direct questions, comments, or suggestions to:

KVH Industries, Inc.

50 Enterprise Center
Middletown, RI 02842-5279 USA
Tel: +1 401 847-3327
Fax: +1 401 849-0045
E-mail: info@kvh.com
Internet: www.kvh.com

KVH Europe A/S

Kokkedal Industripark 2B
2980 Kokkedal, Denmark
Tel: +45 45 160 180
Fax: +45 45 160 181
E-mail: info@kvh.dk
Internet: www.kvh.com

If you have any comments regarding this manual, please e-mail them to manuals@kvh.com. Your input is greatly appreciated!



KVH Part # 54-0419-02 Rev. D
© 2007-2009, KVH Industries, Inc., All rights reserved.
U.S. Patents Pending



TracVision and KVH are registered trademarks of KVH Industries, Inc.

The unique light-colored dome with dark contrasting base is a registered trademark of KVH Industries, Inc.

DVB (Digital Video Broadcasting) is a registered trademark of the DVB Project.

DIRECTV is an official trademark of DIRECTV, Inc.

DISH Network is an official trademark of EchoStar Communications Corporation.

ExpressVu is a property of Bell ExpressVu, a wholly owned subsidiary of Bell Satellite Services.

All other trademarks are the property of their respective owners.



Table of Contents

1	Introduction	
	Using this Manual	3
	System Overview	5
	Circular and Linear Versions.....	8
2	Operation	
	Receiving Satellite TV Signals	13
	Turning the System On/Off	14
	Changing Channels and Switching Between Satellites (Circular Versions)	15
	Changing Channels and Switching Between Satellites (Linear Versions).....	21
	Receiver Requirements	24
	Product Care	26
3	Settings	
	Updating Latitude and Longitude Data	29
	Displaying the Calculated Skew Angle	30
	Adjusting the Skew Angle (Linear Versions).....	31
	Setting Sleep Mode	35
	Setting Instant On.....	36
	Adjusting Display Brightness	37
	DISH Network/ExpressVu Setup	38
	DIRECTV Dual-Sat Mode Setup.....	44
	Circular Custom Dual-Sat Setup.....	45

3	Settings (Continued)	
	European Tri-Sat Mode Setup.....	48
	Linear Dual-Sat Mode Setup.....	50
	Selecting Automatic or Manual Satellite Switching.....	53
	Resetting to Factory Default Settings.....	54
	Restarting the TracVision System.....	55
4	Troubleshooting	
	Five Simple Checks.....	59
	Troubleshooting Matrix.....	60
	Causes and Remedies for Operational Issues.....	61
	Technical Support.....	65
A	Advanced Settings and Functions	
	Manually Controlling the Antenna.....	69
	Updating Satellite Frequency Data.....	70
	Configuring Satellite Settings.....	72
	Displaying Software Version Information.....	73
	Displaying the Antenna Serial Number.....	74
B	Position Grids	
	European Position Grid.....	77
	North American Position Grid.....	78
C	Wiring Diagrams	
	Wiring Diagram for One or Two Receivers.....	81
	Wiring Diagram for Three or Four Receivers (Circular Versions)*.....	82
	Wiring Diagram for Three or Four Receivers (Linear Quad-output Versions).....	83



1. Introduction

This chapter provides a basic overview of this manual and your TracVision system.

Contents

Using this Manual 3
System Overview 5
Circular and Linear Versions..... 8

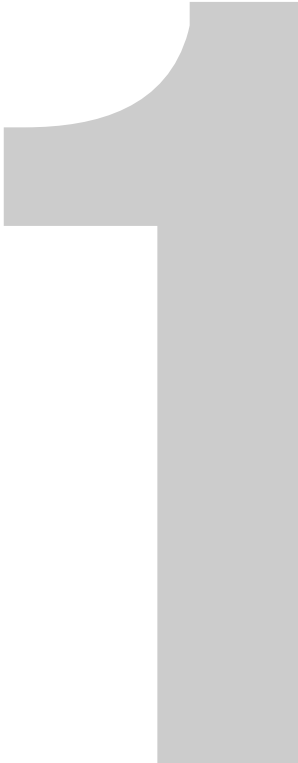



Using this Manual

This manual provides complete operation, setup, and troubleshooting information for your TracVision system, as well as wiring diagrams for various TracVision M5/M7 system configurations.

Who Should Use This Manual

The **user** should refer to the “Operation” chapter to learn how to operate the system.

The **user, installer, or servicing technician** should refer to the “Settings” chapter for information on configuring the system and the “Wiring Diagrams” appendix for information on connecting additional receivers.

The **user and/or servicing technician** should refer to the “Troubleshooting” chapter to help identify the cause of a system problem.

Notifications Used in this Manual

This manual uses the following notifications to call attention to important information:

	CAUTION
This is a danger, warning, or caution notice. Be sure to read these carefully to avoid injury!	

<i>IMPORTANT!</i>
This is an important notice. Be sure to read these carefully to ensure proper operation and configuration of your TracVision system.

NOTE: Notes contain useful information about system settings.

TIP: Tips contain helpful information, allowing you to get the most out of your TracVision system.

Typographical Conventions

This manual uses the following typographical conventions:

Text Example	Description
<SAT NAME> ###	Text in brackets or the pound sign (#) indicates a variable portion of the MultiSat Control Panel (MCP) display

MultiSat Control Panel (MCP) Interface Conventions

When instructions indicate to select a specific MCP menu option, press the MCP button located directly beneath the menu option.

Figure 1-1 Example of MCP Menu Option and Corresponding Button

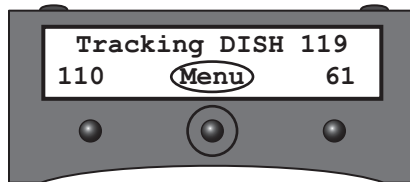

Related Documentation

In addition to this User's Guide, the following documents are provided with your TracVision system:

Document	Description
Installation Guide	Complete product installation instructions
Product Registration Form	Details on registering the product
Warranty Statement	Warranty terms and conditions
Contents List	List of every part supplied in the kit

System Overview

Your TracVision M5/M7 system is a state-of-the-art, actively stabilized antenna system that delivers live satellite TV to your vessel's audio/video entertainment system. A basic system is illustrated below.

Figure 1-2 TracVision System Diagram (Typical Installation)

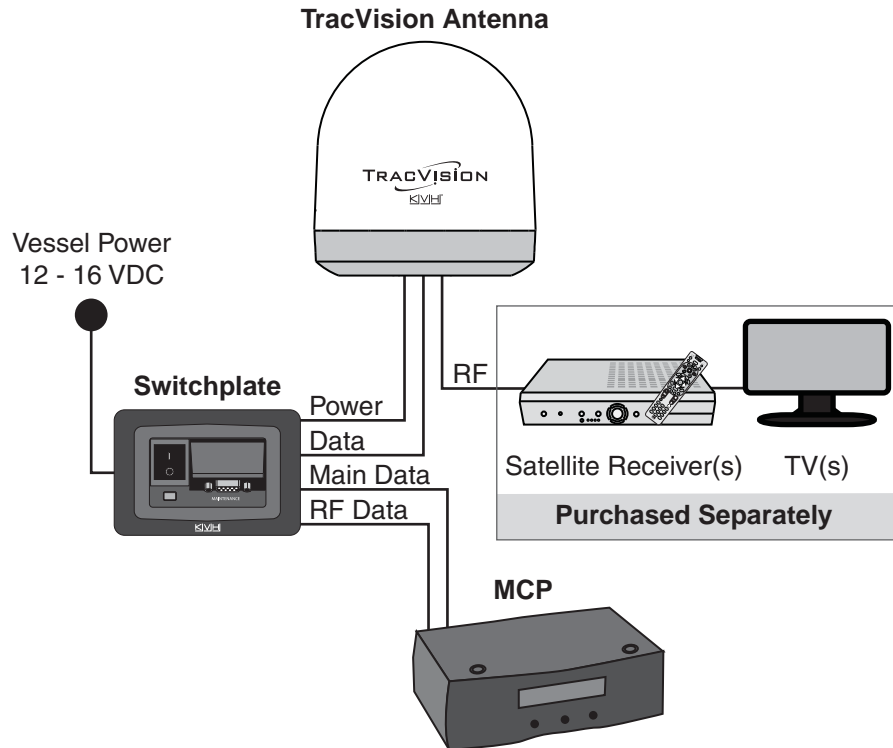

TIP: Receiver wiring diagrams are provided in Appendix C on page 79.

System Components

The TracVision M5/M7 system includes the following components:

Antenna Unit

The antenna unit houses the antenna positioning mechanism, LNB (low noise block), and control elements within a radome. Weathertight connectors join the power, signal, and control cabling from the belowdecks units.

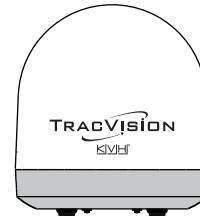

Switchplate

The switchplate controls power to the antenna via the On/Off switch.



MCP (MultiSat Control Panel)

The MCP is the system's user interface, providing access to the system and its functions through an LCD with three buttons. The MCP serves as the system's junction box, and allows you to configure and operate the antenna.

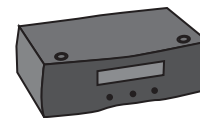



System Features

Your TracVision M5/M7 system uses integrated DVB technology to quickly acquire and track the correct satellite, switch between your selected satellites, and send TV signals to the receiver.

In-motion Tracking

The TracVision system uses a state-of-the-art actively stabilized antenna. Once the satellite is acquired, the antenna's internal gyros and control system continuously measure the heading, pitch, and roll of your vessel, keeping the antenna pointed at the satellite at all times - even while you're on the move!

Satellite Tracking and Switching

Your TracVision M5/M7 system tracks your selected satellites as long as the vessel is located within the selected satellites' coverage area. During installation, your TracVision system should have been set up to track your desired satellites, allowing you to switch between them quickly and easily.

Satellite Library

The TracVision M5/M7 system includes a pre-programmed satellite library of the most popular satellite services, offering a wide variety of satellite services to choose from. For complete information on the satellite library, see Chapter 3 "Settings" on page 27.

TIP: You can add two more satellites of your choice to the satellite library. For complete information on adding satellites to the library, refer to the associated Application Note on the KVH Partner Portal (KVH-authorized technicians only).

Circular and Linear Versions

Your TracVision system is configured to receive either circularly polarized satellite signals (e.g., North America) or linearly polarized satellite signals (e.g., Europe or Latin America). Figure 1-3 illustrates the difference between these two polarizations.

Figure 1-3 Polarizations of Satellite Signals

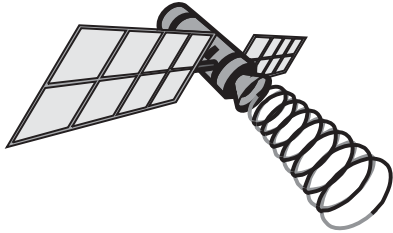
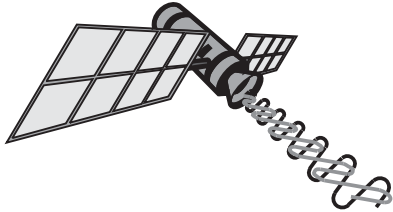
Circular	Linear
	
<p>Signals transmitted in two "corkscrew" patterns, one running clockwise and one running counter-clockwise</p>	<p>Signals transmitted in vertical and horizontal "waves" offset exactly 90° from each other</p>

LNB Skew Angle

Since linear satellite signals are oriented in a precise cross pattern, the TracVision antenna's receiving element, called an LNB (low-noise block), must be oriented in the same way to optimize reception. This orientation adjustment is referred to as the LNB's "skew angle." Figure 1-4 illustrates how skew determines the amount of a linear signal that the LNB collects. The more signal, the better the reception.

Figure 1-4 How Skew Works

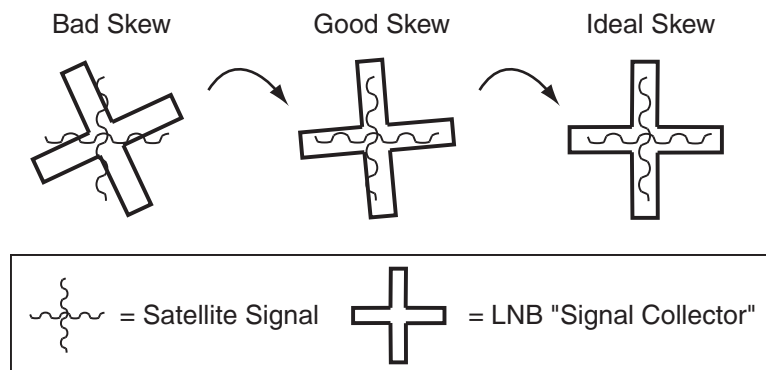

The correct skew setting varies depending on your geographic location, since the orientation of your antenna to the satellite changes as you move. For example, if your antenna is tracking the PAS 9 satellite for Sky Mexico programming, the ideal skew setting ranges from +30 to +70, depending upon your location within the satellite's coverage area (see Figure 1-5).

Figure 1-5 Approximate Skew Settings for the PAS 9 Satellite

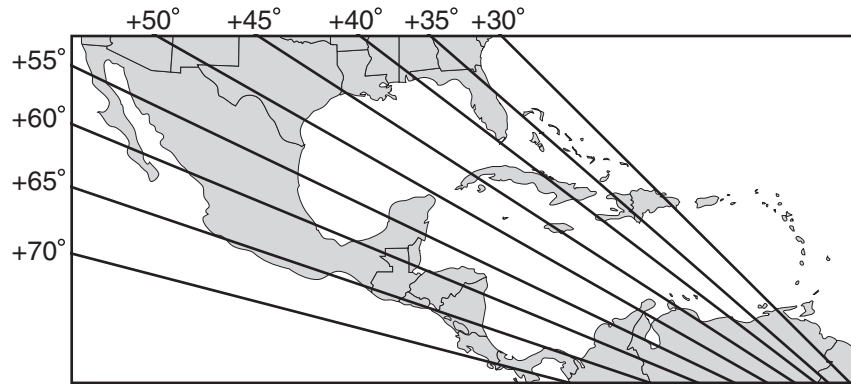

For complete details about adjusting the LNB's skew, see "Adjusting the Skew Angle (Linear Versions)" on page 31.



2. Operation

This chapter explains everything you need to know to operate the TracVision system.

Contents

Receiving Satellite TV Signals	13
Turning the System On/Off	14
Changing Channels and Switching Between Satellites (Circular Versions)	15
Changing Channels and Switching Between Satellites (Linear Versions)	21
Receiver Requirements	24
Product Care	26



Receiving Satellite TV Signals

Television satellites are located in fixed positions above the Earth's equator and beam TV signals down to certain regions of the planet (not worldwide). To receive TV signals from a satellite, you must be located within that satellite's unique coverage area.

TIP: For your convenience, KVH provides links to several websites that offer satellite coverage information. Simply visit our website at www.kvh.com/footprint.

Figure 2-1 Location and Coverage Area of DIRECTV 101 Satellite



In addition, since TV satellites are located above the equator, the TracVision antenna must have a clear view of the sky to receive satellite TV signals. Anything that stands between the antenna and the satellite can block the signal, resulting in lost reception. Common causes of blockage include boat masts, trees, buildings, and bridges. Heavy rain, ice, or snow might also temporarily interrupt satellite signals.

Figure 2-2 Example of Satellite Blockage

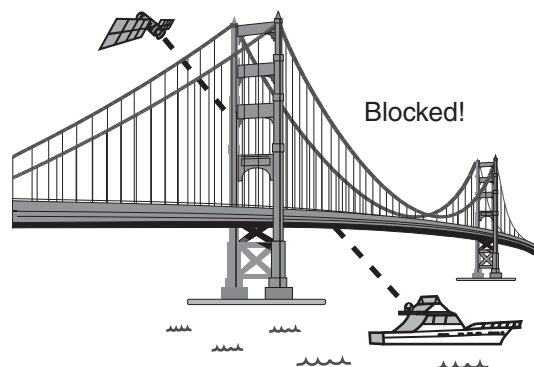

Turning the System On/Off

You can turn the system on or off using the switchplate.

Turning On the System

Follow the steps below to turn on your TracVision system.

IMPORTANT!

Avoid turning the vessel or changing channels for one minute after turning on the system.

1. Make sure the antenna has a clear view of the sky.
2. Turn on your satellite TV receiver and TV.
3. Set the switchplate's Power switch to the On (|) position.

Figure 2-3 Switchplate Power Switch

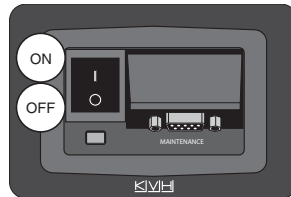

4. Wait one minute for system startup.

Turning Off the System

Follow the steps below to turn off your TracVision system.

1. Set the switchplate's Power switch to the Off (O) position.
2. Turn off your satellite TV receiver and TV.

Changing Channels and Switching Between Satellites (Circular Versions)

During installation, your TracVision system should have been set up to track the satellite(s) of your choice and the channel guides for your selected satellite service should have been downloaded.

Since some channels might be located on another satellite, changing channels might require switching between satellites. With most TracVision configurations, satellite switching occurs automatically while you change channels using the primary receiver's remote control. Find your selected service and configuration in the following sections for complete details.

TIP: *The primary receiver is the receiver connected to the antenna's RF1 connector.*

DISH 1000 (Required for TurboHD Service)

When the TracVision M5/M7 system is configured for DISH 1000, you can view the DISH HDTV programming for your geographic area. The system can be configured for either DISH 1000/61 or DISH 1000/129 use.

Figure 2-4 DISH 1000 Configurations

Configuration	Satellites Tracked
DISH 1000/61	DISH 110, 119, and 61
DISH 1000/129	DISH 110, 119, and 129

During installation, your TracVision system should have been set to the DISH 1000 configuration that best suits your geographic location (see Figure 2-5) and local channels requirements. If you change satellite coverage areas, refer to "DISH Network/ExpressVu Setup" on page 38 to change your DISH 1000 configuration.

Figure 2-5 Regional DISH 1000 Configuration Recommendations

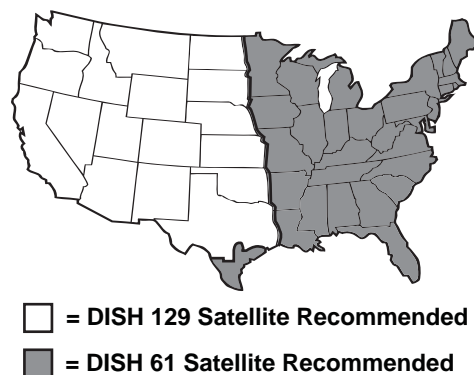

DISH 1000 Automatic Mode - Preferred for One or Two Receivers

The antenna switches between satellites automatically as you change channels using the primary receiver's remote control. The primary receiver is the receiver connected to RF1 (see Figure 2-6 and Figure 2-7). If an optional secondary receiver is connected, you can use its remote control to switch between the channels on the currently selected satellite.

Figure 2-6 DISH 1000 Automatic Mode - Receiver Controls

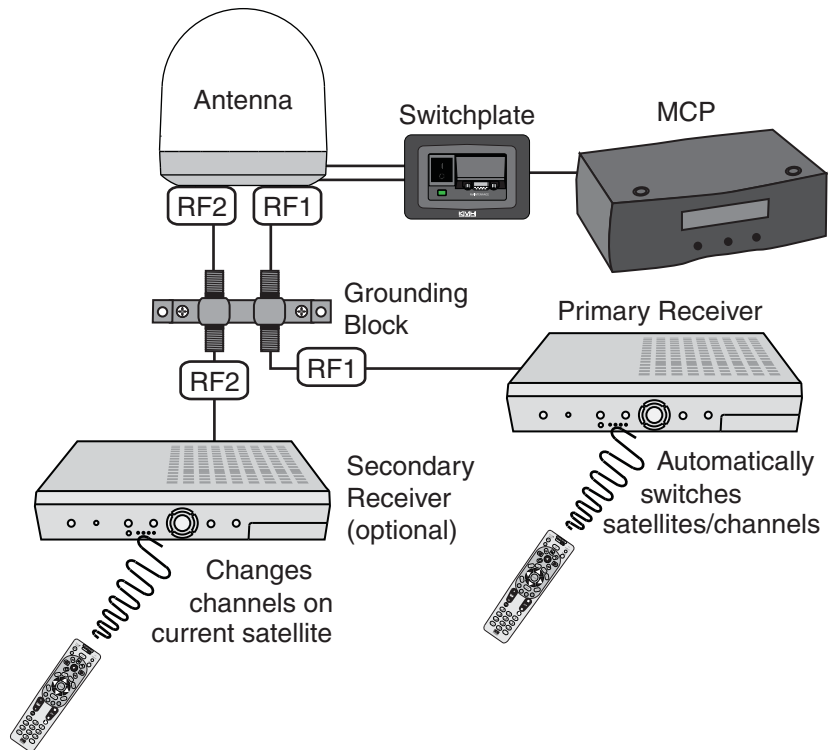
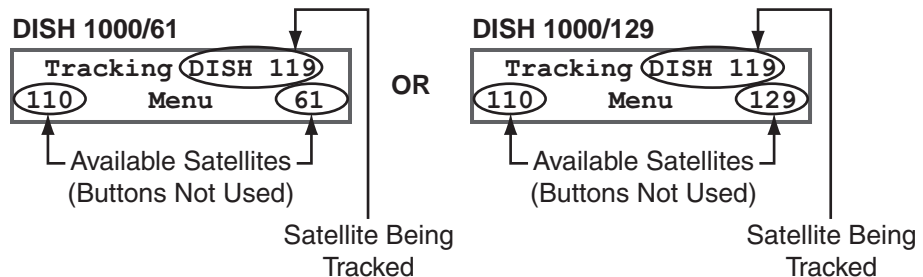

Figure 2-7 DISH 1000 Automatic Mode - MCP Displays



DISH 1000 Manual Mode - Required for Three or More Receivers

Since multiswitches interfere with communications between the receivers and the antenna, the system must be set up in Manual mode when three or more receivers are installed. When Manual mode is enabled, you can switch between your selected satellites using the buttons on the front of the MCP (see Figure 2-8 and Figure 2-9). You can use the receivers' remote controls to switch between the channels on the currently selected satellite.

Figure 2-8 DISH 1000 Manual Mode - Receiver/MCP Controls

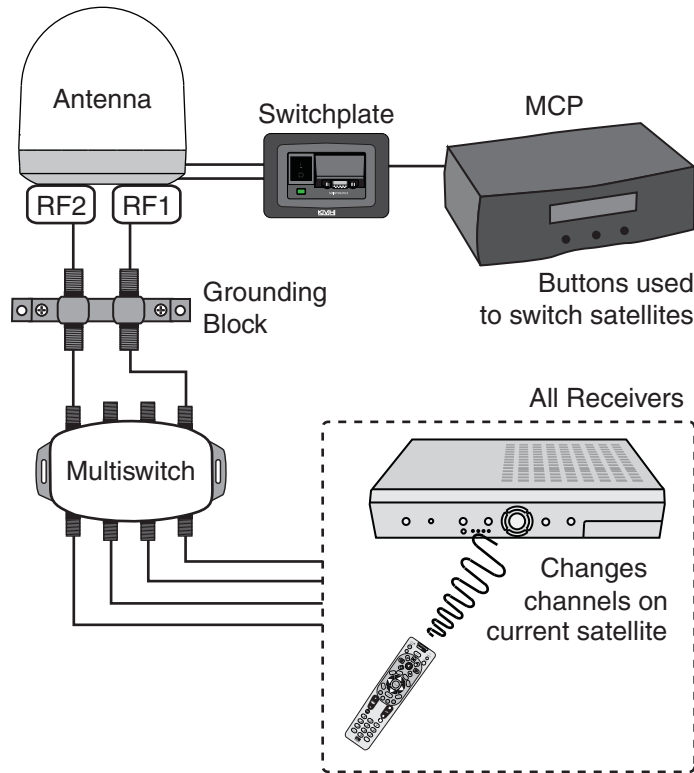
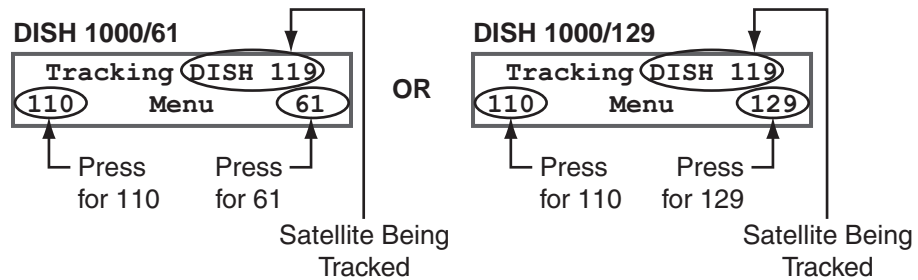

Figure 2-9 DISH 1000 Manual Mode - MCP Displays



Dual-Sat Mode - Required for all DISH 500, ExpressVu, DIRECTV, and Custom Dual-Sat Setups

Dual-Sat Mode is used with several service configurations. Figure 2-10 lists each Dual-Sat service configuration, the satellites tracked for each service, and available satellite switching modes.

Figure 2-10 Dual-Sat Modes

Service	Satellites Tracked	Available Switching Mode(s)
DIRECTV	DIRECTV 101 and 119	Auto or Manual
DISH 500	DISH 119 and 110	Auto or Manual
ExpressVu	ExpressVu 91 and 82	Auto or Manual
Custom	Selected by user	Manual

Dual-Sat Automatic Mode - Preferred Mode for One or Two Receivers*

The antenna switches between satellites automatically while you change channels using the primary receiver's remote control. The primary receiver is the receiver connected to the antenna's RF1 cable (see Figure 2-11 and Figure 2-12). If an optional secondary receiver is connected, you can use its remote control to switch between the channels on the currently selected satellite.

***NOTE:** Custom Dual-Sat configurations must use Manual mode.

Figure 2-11 Dual-Sat Automatic Mode - Receiver Controls

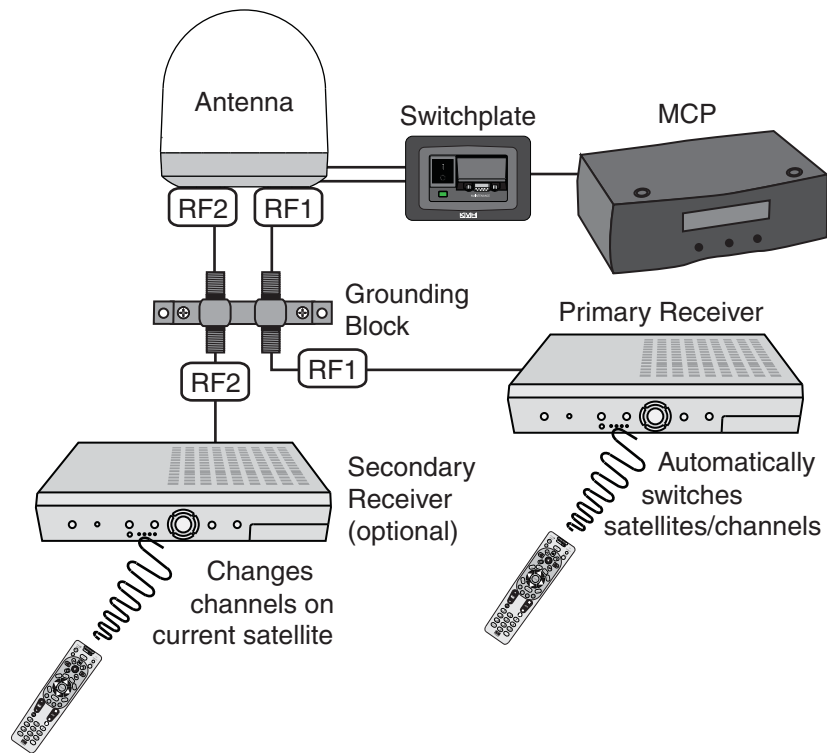
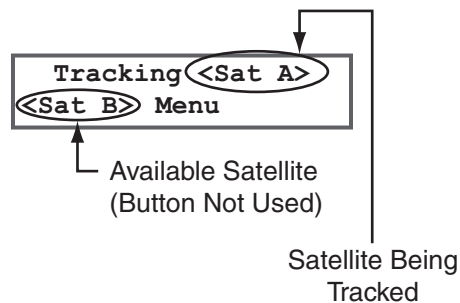

Figure 2-12 Dual-Sat Automatic Mode - MCP Display



Dual-Sat Manual Mode - Required for Three or More Receivers and All Custom Dual-Sat Setups

Circular TracVision M5/M7 systems with three or more receivers require the use of a multiswitch. Since multiswitches interfere with communications between the receivers and the antenna, the system must be set up in Manual mode. When manual mode is enabled, you can use the receiver's remote control to change channels on the currently selected satellite. If you need to switch satellites, simply use the buttons on the front of the MCP (see Figure 2-13 and Figure 2-14). You can use the receivers' remote controls to switch between the channels on the currently selected satellite.

Figure 2-13 Dual-Sat Manual Mode - Receiver/MCP Controls

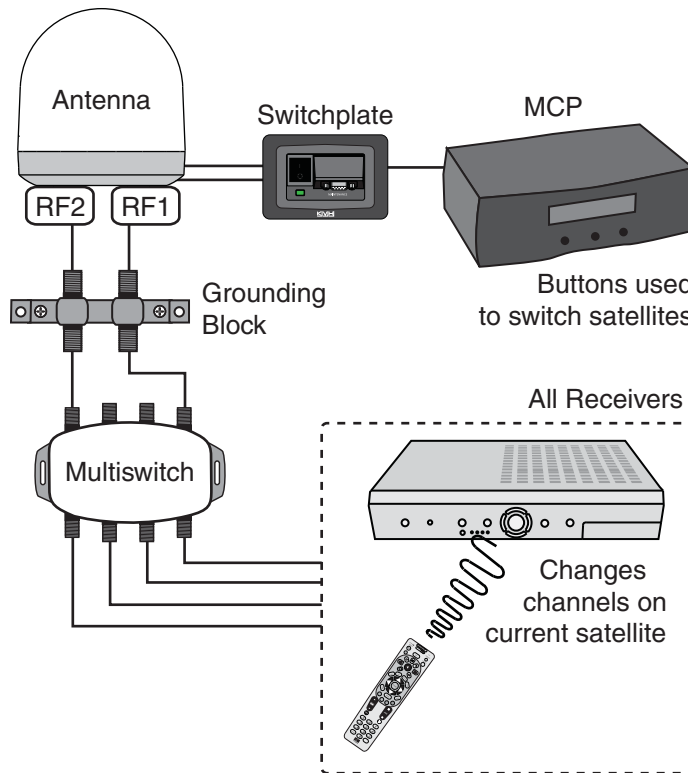
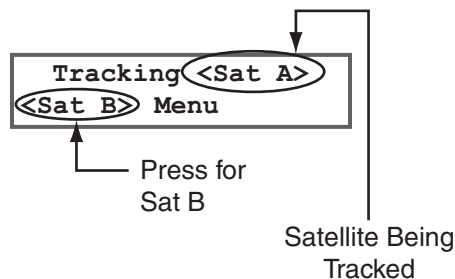

Figure 2-14 Dual-Sat Manual Mode - MCP Display





Changing Channels and Switching Between Satellites (Linear Versions)

During installation, your TracVision system should have been set up to track the satellite(s) of your choice and the channel guides for your selected satellite service should have been downloaded.

Since some channels might be located on another satellite, changing channels might require switching between satellites. Switching satellites occurs automatically with most TracVision system configurations. However, if the TracVision system includes a multiswitch, manual satellite switching is required.

NOTE: *To enable automatic switching, the receiver must be properly configured (see “Linear Receiver Configuration” on page 25 for more information).*

Automatic Satellite Switching

The TracVision system can switch between satellites automatically as long as the primary receiver is set up for DiSEqC communications and a multiswitch is not installed. With DiSEqC set up, the primary receiver sends satellite switching commands to the antenna as necessary when you change channels using the primary receiver's remote control. The primary receiver is the receiver connected to the antenna's RF1 cable (see Figure 2-15). If an optional secondary receiver is connected, you can use its remote control to switch between the channels on the currently selected satellite.

Figure 2-15 Primary/Secondary Receiver Control (Dual-output version shown)

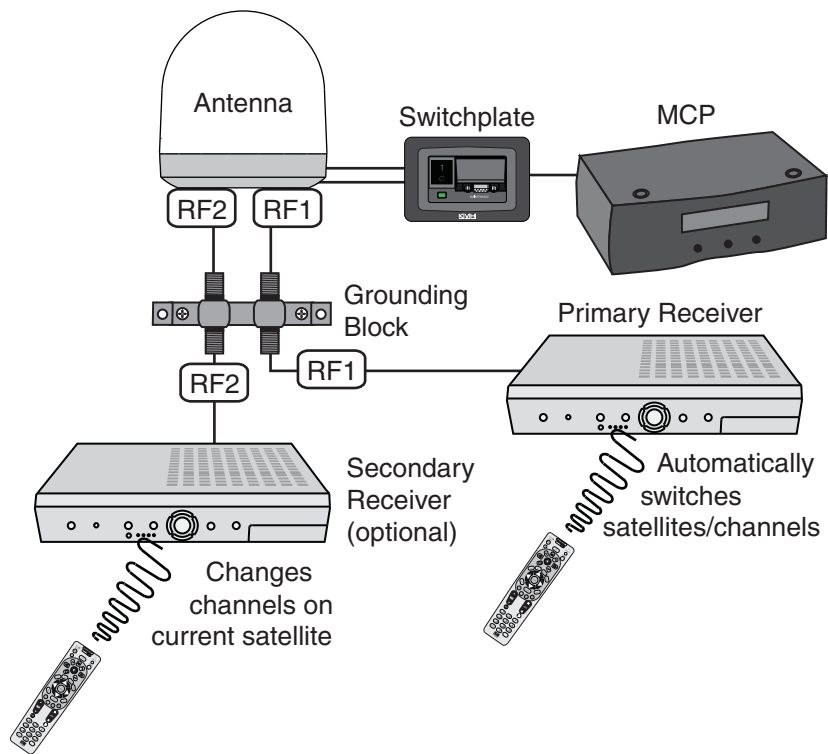
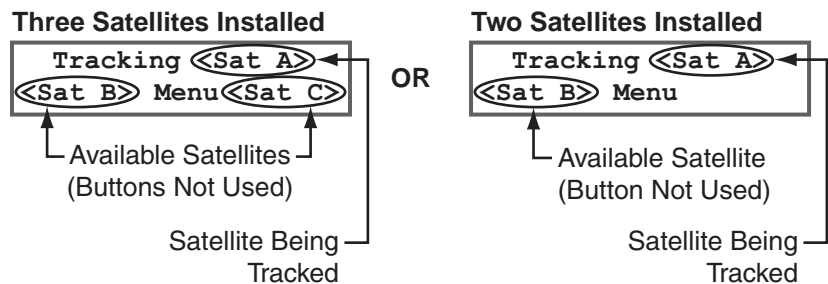

Figure 2-16 Automatically Switching Between Satellites - MCP Displays



Manual Satellite Switching

If the TracVision system includes a multiswitch, you can use the receivers' remote controls to change channels on the currently selected satellite. If you need to switch satellites, simply use the buttons on the front of the MCP (see Figure 2-17 and Figure 2-18).

Figure 2-17 Manual Satellite Switching - Receiver/MCP Controls (Quad-output version shown)

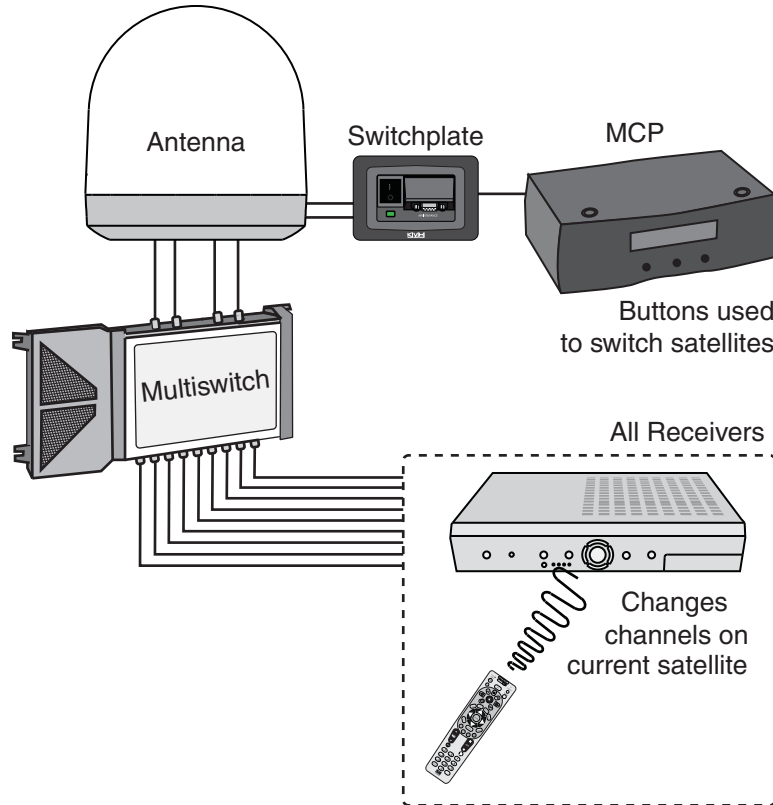
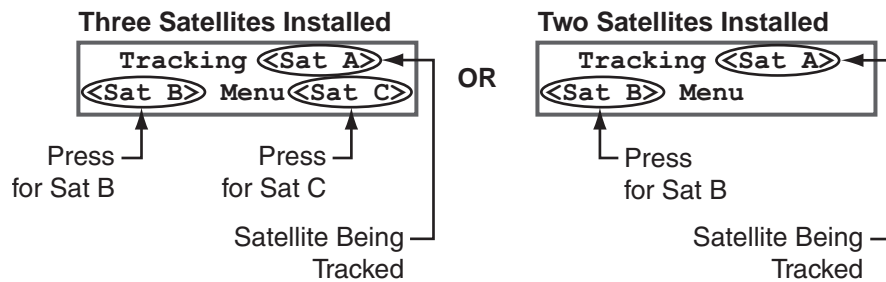

Figure 2-18 Manually Switching Between Satellites - MCP Displays



Receiver Requirements

This section lists U.S. and Canadian circular receiver models that are compatible with the TracVision M5/M7 system and explains linear and circular receiver setup requirements.

Circular Receiver Compatibility

To ensure compatibility with your TracVision M5/M7 system, be sure to use a KVH-validated receiver for your selected service type (see Figure 2-19).

Figure 2-19 KVH-Validated U.S. and Canadian Receivers

Standard-definition receivers		
DIRECTV	DISH	ExpressVu
D12	311	4100
D11		3100
D10		
High-definition receivers		
DIRECTV	DISH	ExpressVu
HD not supported	211k 211	6100

NOTE: For information on connecting different receiver models, contact KVH Technical Support at 1-401-847-3327.

DISH Network/ExpressVu Receiver Configuration

If your TracVision M5/M7 system is set up for DISH Network or ExpressVu service, your receiver(s) should have also been configured during installation. In most cases, you do not need to reconfigure your receiver(s). However, Figure 2-20 lists special scenarios that require DISH Network/ExpressVu receiver configuration.

Figure 2-20 Receiver Configuration Requirements

Receiver Configuration is Required When...
<ul style="list-style-type: none"> • DISH 1000 only - You change satellite coverage areas (see Figure 2-5 on page 15) • You add a receiver • You have reconfigured a receiver for home use

If you need to configure a receiver(s) for DISH Network/ExpressVu use, follow the instructions for configuring the receiver for your selected service type in Chapter 3 "Settings" on page 27.

Linear Receiver Configuration

If the TracVision system does not include a multiswitch, you can configure the receiver(s) to enable automatic satellite switching. TracVision systems with a multiswitch installed require switching satellites using the MCP, which does not require receiver configuration.

To configure the receivers for automatic switching, the satellites must be set up in the receiver in the same order they were set up in the TracVision system (see Figure 2-21).

Figure 2-21 Antenna/Receiver Synchronization Settings

TracVision Satellite	Receiver Satellite	DiSEqC Setting
Satellite A	Alternative 1 or A	DiSEqC 1
Satellite B	Alternative 2 or B	DiSEqC 2
Satellite C*	Alternative 3 or C	DiSEqC 3

**NOTE: Only European Tri-Sat configurations track three satellites.*

Product Care

Please consider the following antenna care guidelines for maintaining peak performance:

- Periodically wash the exterior of the antenna dome with fresh water and mild detergent. Avoid harsh cleansers and volatile solvents (such as acetone) and do not spray the dome directly with high-pressure water.
- If you wish to paint the dome, use only non-metallic automotive paint without a primer coat. Any paint that contains metal will block satellite signals and impair reception.



3. Settings

This chapter contains information on system settings and how to modify them.

Contents

Updating Latitude and Longitude Data	29
Displaying the Calculated Skew Angle	30
Adjusting the Skew Angle (Linear Versions).....	31
Setting Sleep Mode	35
Setting Instant On	36
Adjusting Display Brightness.....	37
DISH Network/ExpressVu Setup	38
DIRECTV Dual-Sat Mode Setup.....	44
Circular Custom Dual-Sat Setup	45
European Tri-Sat Mode Setup	48
Linear Dual-Sat Mode Setup.....	50
Setting Manual or Automatic Switching.....	53
Resetting to Factory Default Settings.....	54
Restarting the TracVision System	55

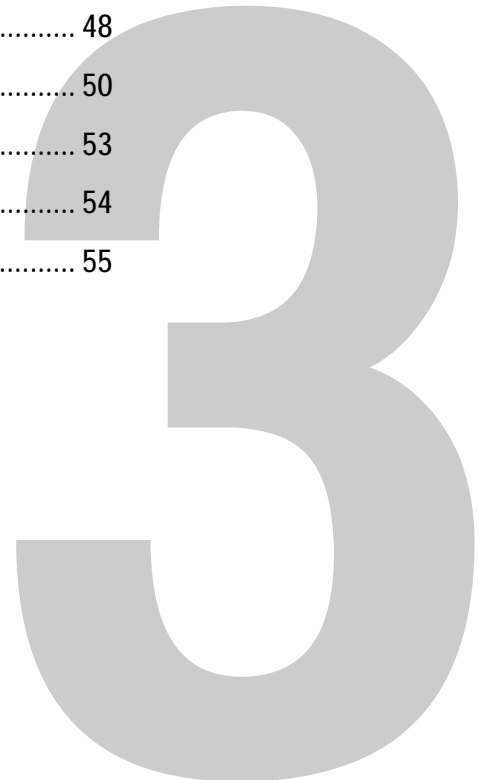

Updating Latitude and Longitude Data

Use the flowchart in Figure 3-1 if you wish to update your latitude and longitude data.

TIP: For your convenience, you can determine your approximate latitude and longitude using the Position Grids provided in Appendix B on page 75.

Figure 3-1 Updating Latitude and Longitude Data

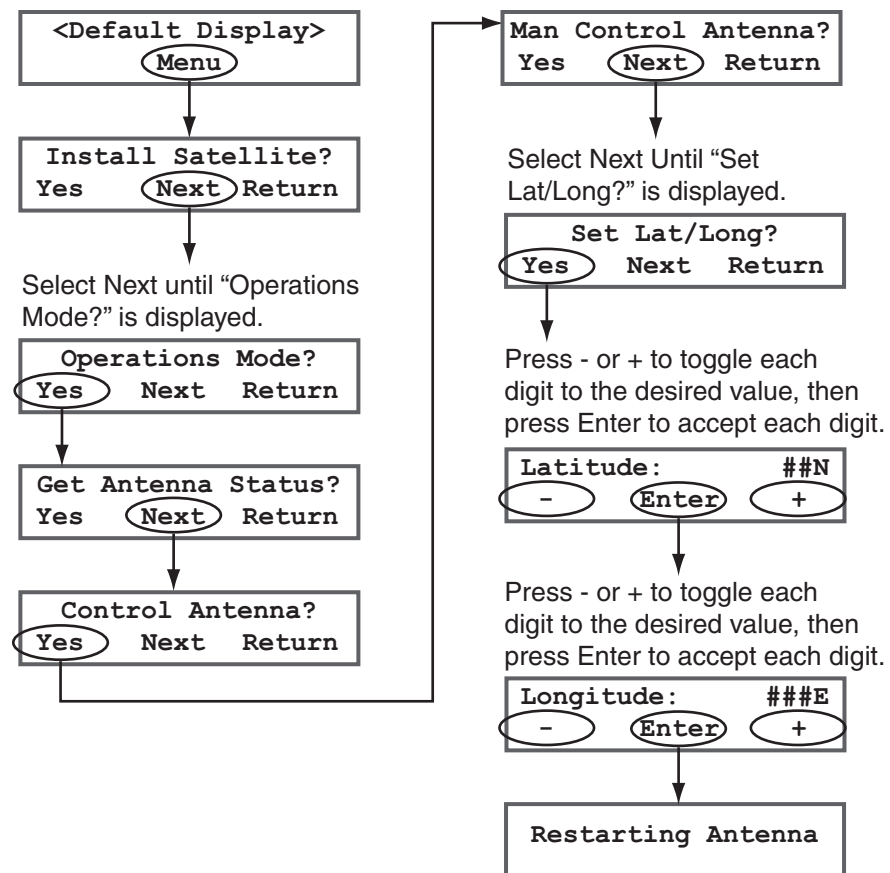

Displaying the Calculated Skew Angle

Use the flowchart in Figure 3-2 to display the average skew angle for your selected satellites. If just one satellite is configured for tracking, that satellite's skew angle is displayed.

IMPORTANT!

An accurate skew angle reading requires current latitude and longitude data. If necessary, be sure to update the latitude and longitude data before proceeding (see "Updating Latitude and Longitude Data" on page 29 for more information).

Figure 3-2 Displaying the Calculated Skew Angle

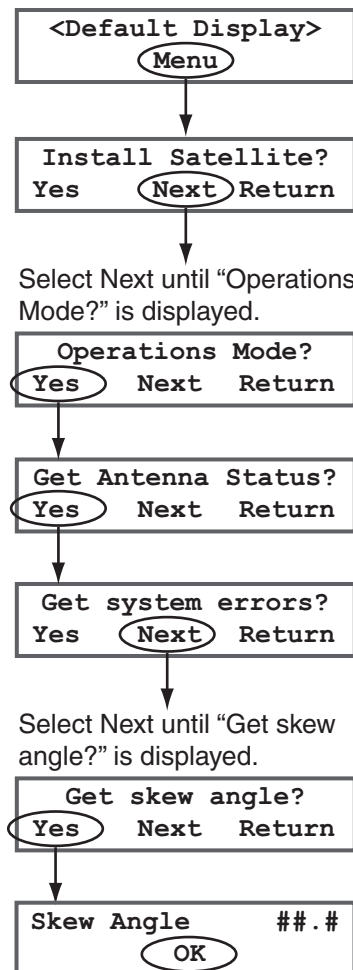

Adjusting the Skew Angle (Linear Versions)

Once you have determined the proper skew angle, follow the steps below to adjust the antenna's LNB skew angle.

TIP: Refer to "Displaying the Calculated Skew Angle" on page 30 to determine the skew angle for the currently selected satellite. If you wish to determine the average skew angle for two or three satellites, see "European Tri-Sat Mode Setup" on page 48 or "Linear Dual-Sat Mode Setup" on page 50.

TIP: For information on how skew works, see "LNB Skew Angle" on page 8.



CAUTION

To avoid bodily injury, be sure to turn off the antenna and disconnect power to all wired components.

1. Using a Phillips-head screwdriver, remove the screws securing the radome. Then remove the radome and set it aside in a safe place.
2. Locate the LNB assembly on the back of the antenna reflector.

Figure 3-3 Location of LNB on Back of Antenna Reflector

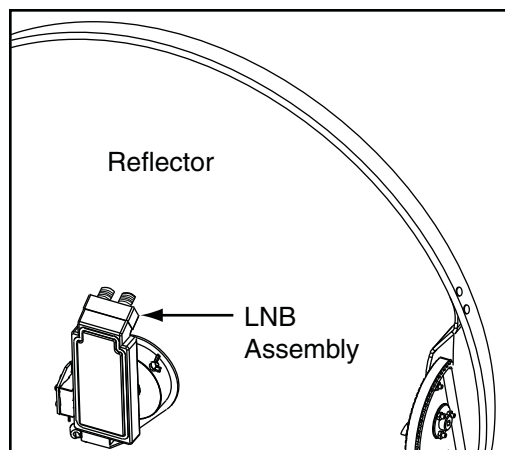

- Using a 2 mm allen hex key, loosen the two M4 socket set screws securing the LNB. The location of the screws varies according to TracVision model; refer to Figure 3-4 or Figure 3-5.

Figure 3-4 TracVision M5 Set Screws

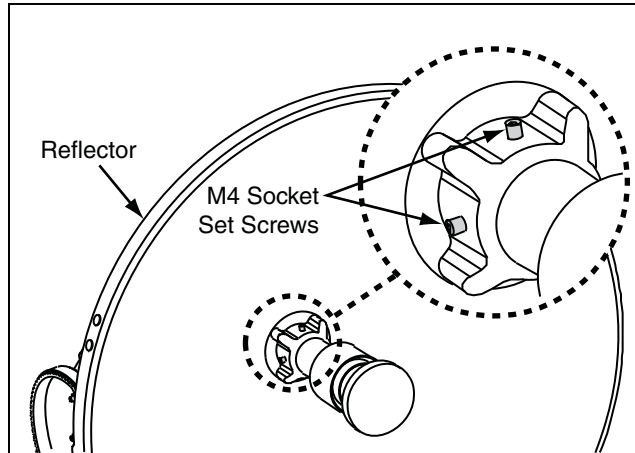
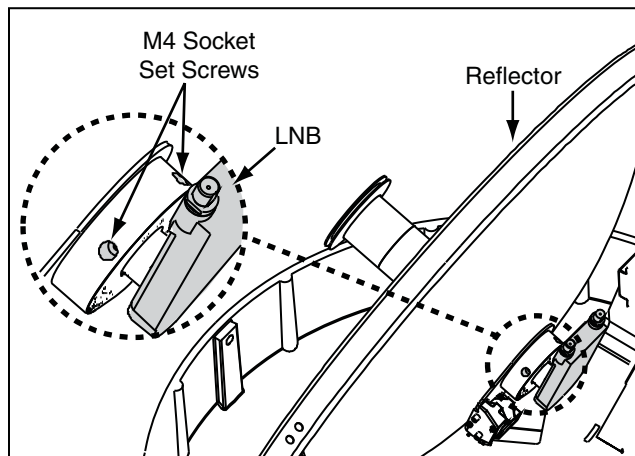

Figure 3-5 TracVision M7 Set Screws



- 4a. TracVision M5 Only** - Adjust the LNB clockwise or counter-clockwise, until the skew arrow on the LNB points to the skew angle that you determined earlier. Due to label constraints, if the skew angle is greater than $+15^\circ$, you need to subtract 180 to get the equivalent negative skew angle and set the LNB to that angle instead. For example, if the skew angle is determined to be $+30^\circ$, set the skew to -150° .

IMPORTANT!

Be sure to keep the LNB fully inserted in the choke feed to ensure optimum performance.

Figure 3-6 TracVision M5 LNB Skew Angle Adjustment

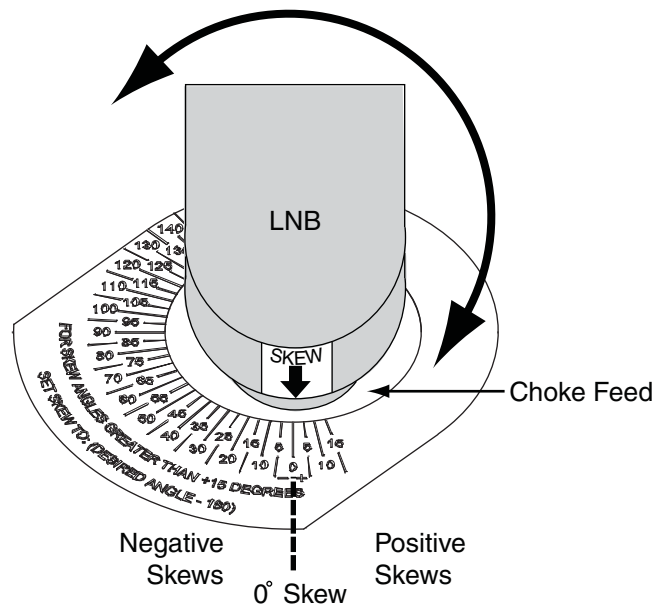

4b. TracVision M7 Only - Adjust the LNB clockwise or counter-clockwise, until the skew arrow on the LNB points to the skew angle that you determined earlier.

IMPORTANT!

Be sure to keep the LNB fully inserted in the choke feed to ensure optimum performance.

Figure 3-7 TracVision M7 LNB Skew Angle Adjustment

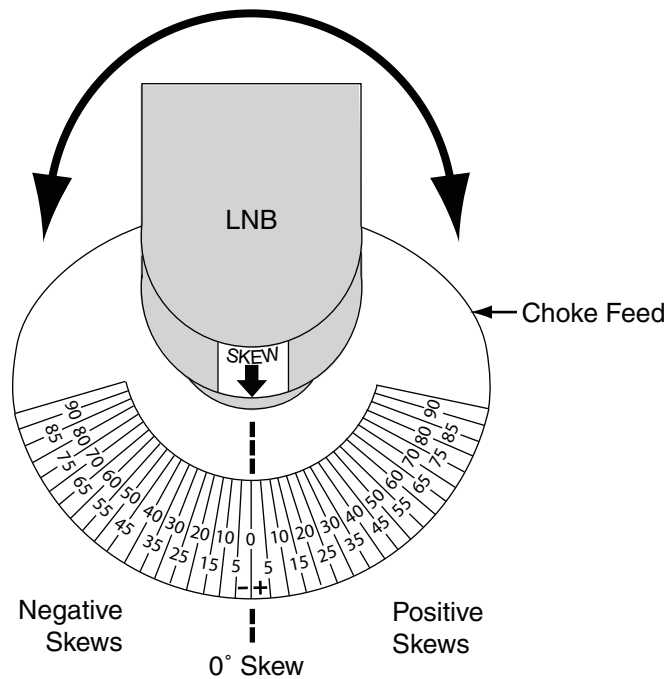

5. Tighten the two M4 socket set screws to secure the LNB in place. Apply 9 in-lbs (1 Nm) of torque, if possible.
6. Reinstall the radome.
7. Restore power to the TracVision system.

Setting Sleep Mode

When the vessel has come to a stop and holds its position for one minute (e.g., at a dock), the antenna unit enters Sleep Mode, which locks the antenna in place to conserve power. As soon as the vessel moves beyond a 1° - 2° window or the signal level changes significantly, Sleep Mode automatically turns off and the system begins tracking the satellite again (or enters Search Mode to find the satellite).

Use the flowchart in Figure 3-8 if you wish to disable Sleep Mode, or if you wish to restore the original Sleep Mode setting.

Figure 3-8 Setting Sleep Mode On/Off

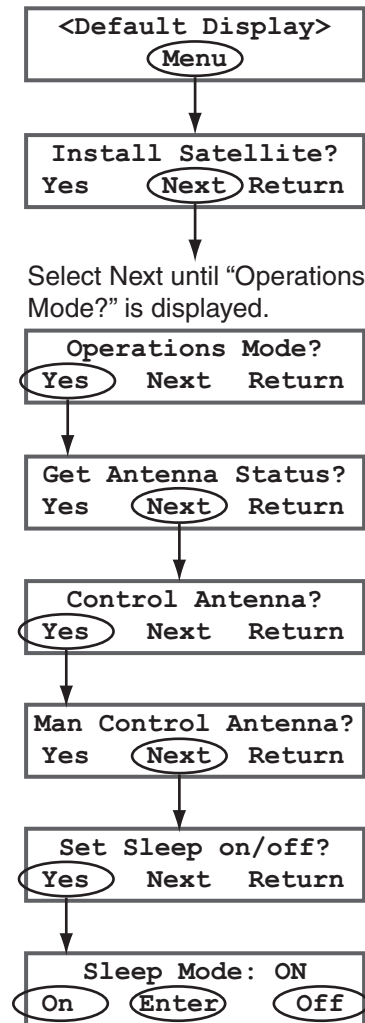

Select On or Off as required, then select Enter.

Setting Instant On

When Instant On is enabled, the antenna can immediately receive signals if the vessel has not moved since the antenna was last shut off. However, if the system is turned off, and then the vessel moves after last acquiring the satellite via Instant On, the antenna will undergo its standard initialization process once it is turned back on. This results in a brief delay.

NOTE: *Instant On is disabled by default and is not recommended for DISH Network and ExpressVu configurations.*

Use the flowchart in Figure 3-9 if you wish to enable Instant On, or if you wish to restore the original setting.

Figure 3-9 Enabling/Disabling Instant On

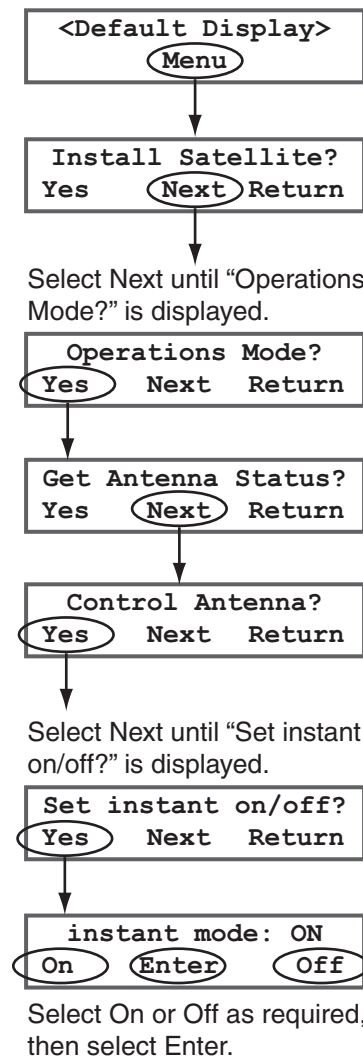

Adjusting Display Brightness

You can adjust the brightness of the MCP's LCD screen to suit your preferences. Use the flowchart in Figure 3-10 if you wish to adjust the display brightness.

Figure 3-10 Setting Display Brightness

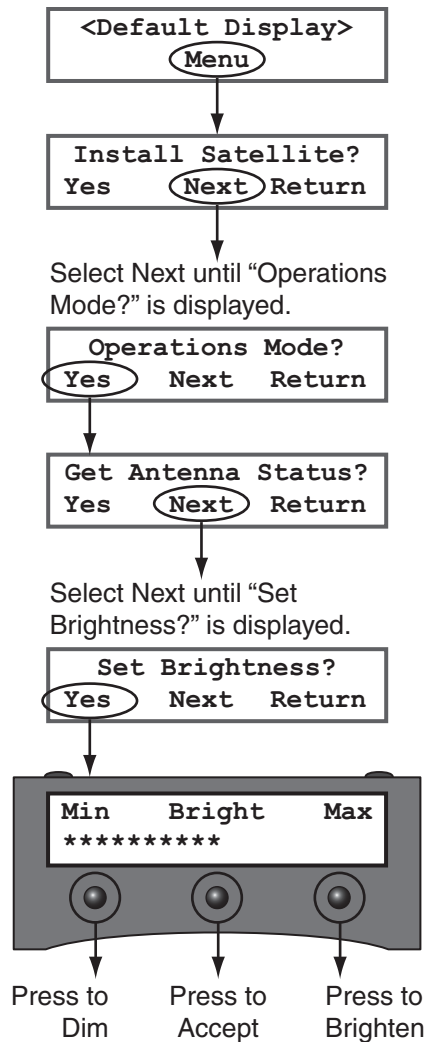

DISH Network/ExpressVu Setup

This section explains how to configure the TracVision system for DISH 1000, DISH 500, or ExpressVu use. For operation instructions and additional information on DISH modes, refer to “Changing Channels and Switching Between Satellites (Circular Versions)” on page 15.

Step 1 - Configure the TracVision System

Use the flowchart in Figure 3-11 on page 39 to configure the TracVision system for DISH Network service. If you need to configure the system for ExpressVu service, see Figure 3-12 on page 40.

IMPORTANT!

This procedure must be performed while the vessel is docked in calm water.

NOTE: For your convenience, you can determine your approximate latitude and longitude using the Position Grids provided in Appendix B on page 75.

Figure 3-11 Configuring DISH Network

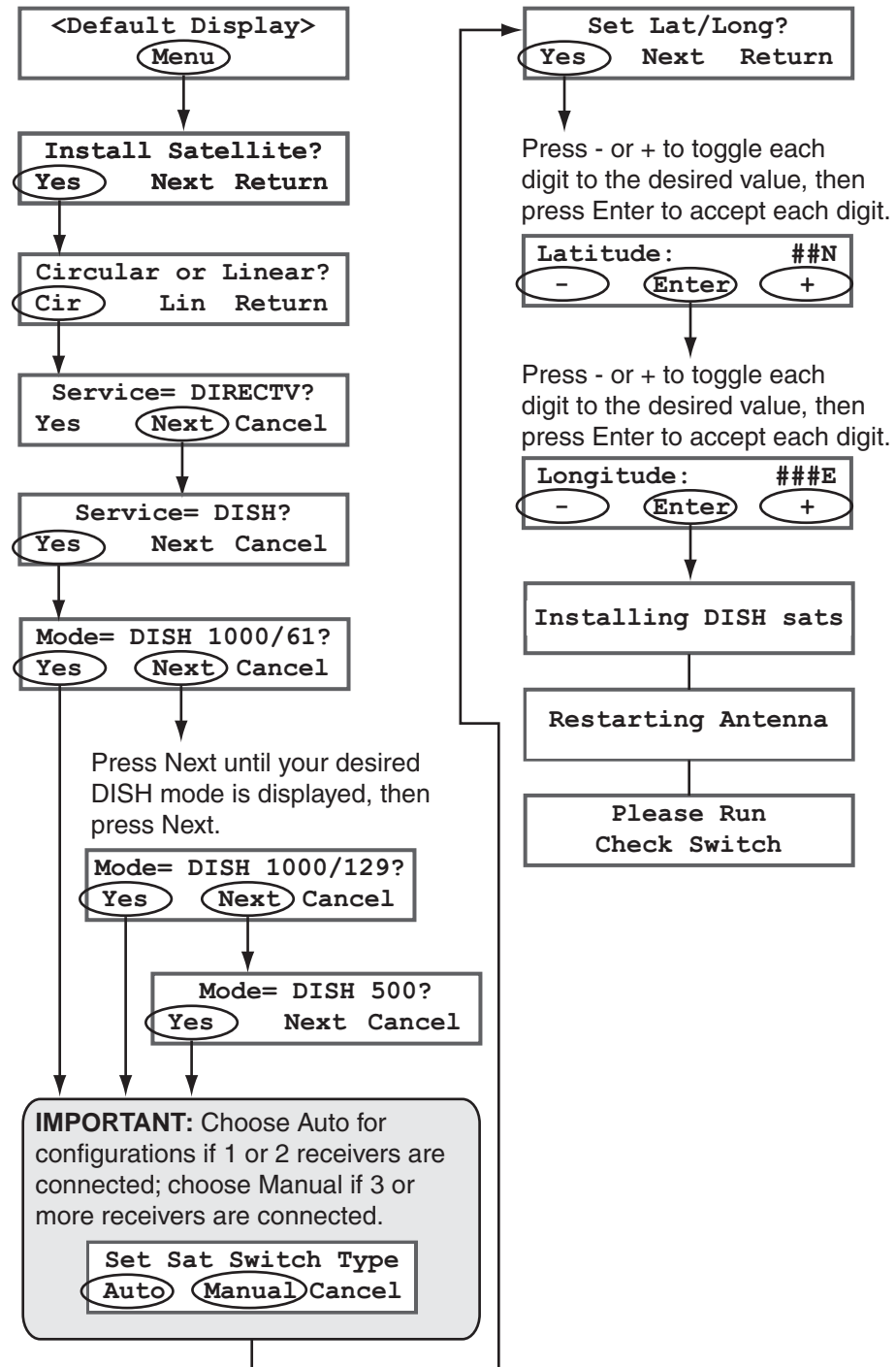
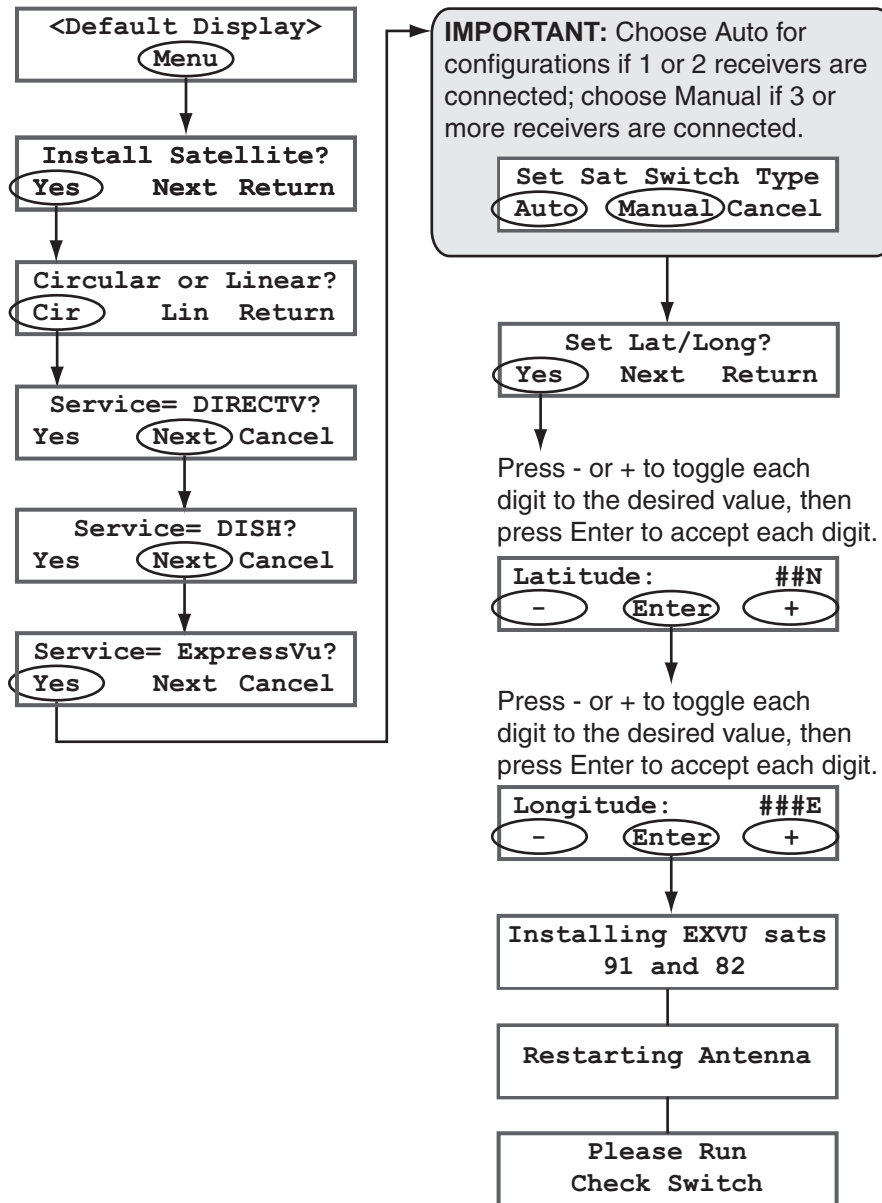

Figure 3-12 Configuring ExpressVu



Step 2 - Configure the Receiver(s)

NOTE: *If you are connecting multiple receivers, repeat this process for each additional receiver. You will need to connect each receiver, one at a time, to the RF1 cable and perform the steps below. Then, once you have completed this process for each receiver, you can reconnect them as desired.*

1. Ensure the receiver you wish to configure is connected to the TracVision system's RF1 cable.
2. Turn on the TV(s) and receiver(s).
3. Using the receiver's remote, go to the "Point Dish/Signal Strength" screen (press MENU, 6, 1, 1 on most models).
4. Choose **Check Switch**, then press SELECT.
5. Choose **Test**, then press SELECT. The MCP displays the "Check Switch Running" screen (see Figure 3-13).

Figure 3-13 Check Switch Running Screen

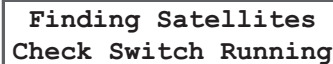

Finding Satellites
Check Switch Running

6. After waiting 15 minutes, check the MCP display. If the "Please Run Check Switch" screen is displayed, repeat Steps 3-5.

IMPORTANT!

Please be patient. The Check Switch test takes approximately 15 minutes to complete. Disregard any messages on the TV stating the test is complete; the antenna must perform additional operations before proceeding.

Figure 3-14 Please Run Check Switch Screen



Please Run
Check Switch

7. Refer to the tables in Figures 3-15 through Figure 3-18 (on the following page) to verify the values on your TV screen match those required for your selected satellite TV service. If your values do not match, turn off the TracVision system, then turn it back on and repeat Steps 3-6.

Figure 3-15 DISH 1000/61 Expected Check Switch Results on TV Screen

Port	1	2	3
Satellite	119	110	61
Trans	OK	OK	OK
Status	Reception Verified		
Switch	SW64		

Figure 3-16 DISH 1000/129 Expected Check Switch Results on TV Screen

Port	1	2	3
Satellite	119	110	129
Trans	OK	OK	OK
Status	Reception Verified		
Switch	SW64		

Figure 3-17 DISH 500 Expected Check Switch Results on TV Screen

Port	1	1	2	2
Satellite	119	119	110	110
Trans	Odd	Even	Odd	Even
Status	Reception Verified			
Switch	SW42			

Figure 3-18 ExpressVu Expected Check Switch Results on TV Screen*

Port	1	1	2	2
Satellite	91	91	82	82
Trans	Odd	Even	Odd	Even
Status	Reception Verified			
Switch	SW21			

****NOTE:** If you installed just one ExpressVu satellite, the TV screen will display an error message instead; this is normal.*

- 8.** Exit the menu and allow the receiver to download the program guide.

***NOTE:** You do not need to configure the receiver again unless you add another receiver, you reconfigure a receiver for home use, or you move to a different DISH 1000 satellite coverage area (see "DISH 1000 (Required for TurboHD Service)" on page 15).*

DIRECTV Dual-Sat Mode Setup

This section explains how to configure the TracVision system to track the DIRECTV 101 and 119 satellites. Use the flowchart in Figure 3-19 to configure the TracVision system for DIRECTV Dual-Sat Mode. For operation instructions, refer to “Changing Channels and Switching Between Satellites (Circular Versions)” on page 15.

NOTE: For your convenience, you can determine your approximate latitude and longitude using the Position Grids provided in Appendix B on page 75.

Figure 3-19 Configuring DIRECTV Dual-Sat Mode

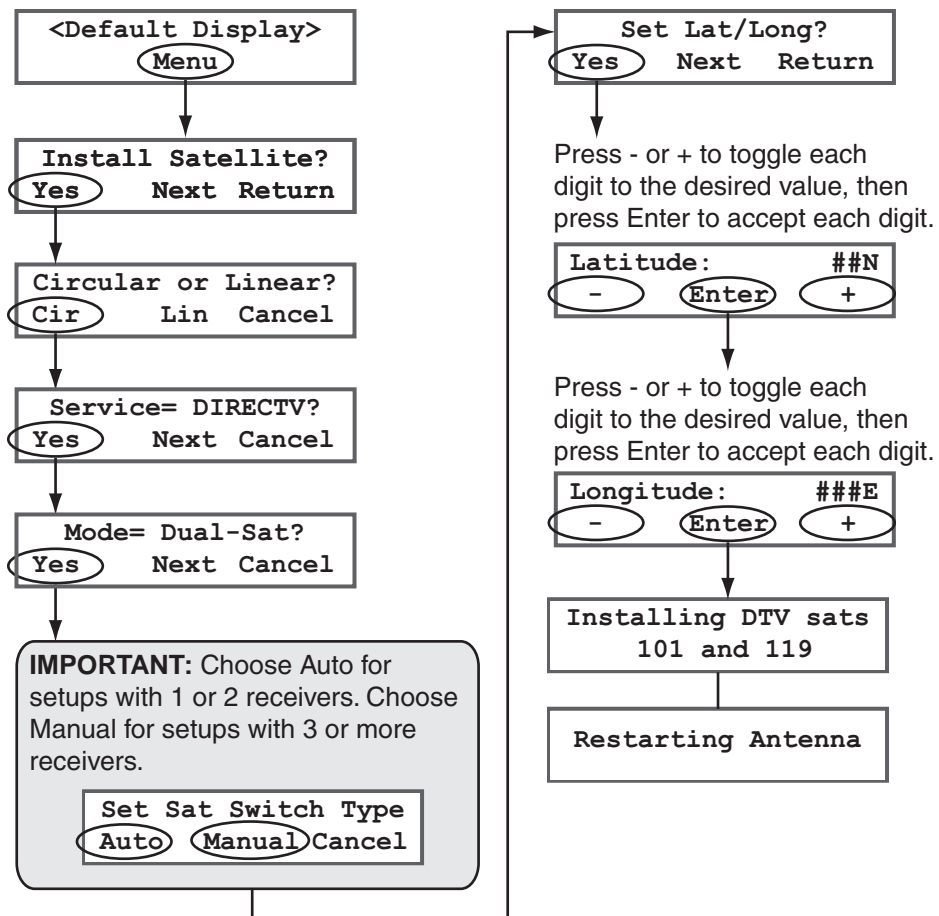

Circular Custom Dual-Sat Setup

The following instructions explain how to configure the TracVision system to track any two satellites of your choice from the circular antenna's circular satellite library (shown in Figure 3-20 on page 46). For operation instructions, refer to "Changing Channels and Switching Between Satellites (Circular Versions)" on page 15.

IMPORTANT!

Most DIRECTV, DISH Network, and ExpressVu subscribers should refer to the previous sections for setup information. The TracVision system should only be configured for Custom Dual-Sat Mode if you wish to install just one satellite or install different satellites than those specified for your satellite service. Refer to "DISH Network/ExpressVu Setup" on page 38 or "DIRECTV Dual-Sat Mode Setup" on page 44 for more information.

NOTE: Be sure to only install satellites that your TracVision M5/M7 system can track in your geographic location. For your convenience, KVH provides links to several websites that offer satellite coverage information. Simply visit our website at www.kvh.com/footprint.

Figure 3-20 Circular Satellite Library

Satellite Service	Satellite Location	Installation Name
AsiaSat 4	122.2° E	ASIASAT*
DIRECTV	72.0° W	DSS_72
	101.0° W	DSS_101
	110.0° W	DSS_110*
	119.0° W	DSS_119
DIRECTV Latin America	95.0° W	GALAXY3CN*
DISH Network	61.5° W	ECHO_61
	110.0° W	ECHO_110
	119.0° W	ECHO_119
	129.0° W	ECHO_129
ExpressVu	91.0° W	EXPRESSTV
	82.0° W	EXPRESSVU

**NOTE: Reception of these satellites requires special hardware. Please contact your local KVH-authorized dealer or KVH Technical Support for details.*

Use the flowchart in Figure 3-21 to configure the TracVision system for your custom pair of satellites (or single satellite).

Figure 3-21 Configuring Custom Dual-Sat Mode

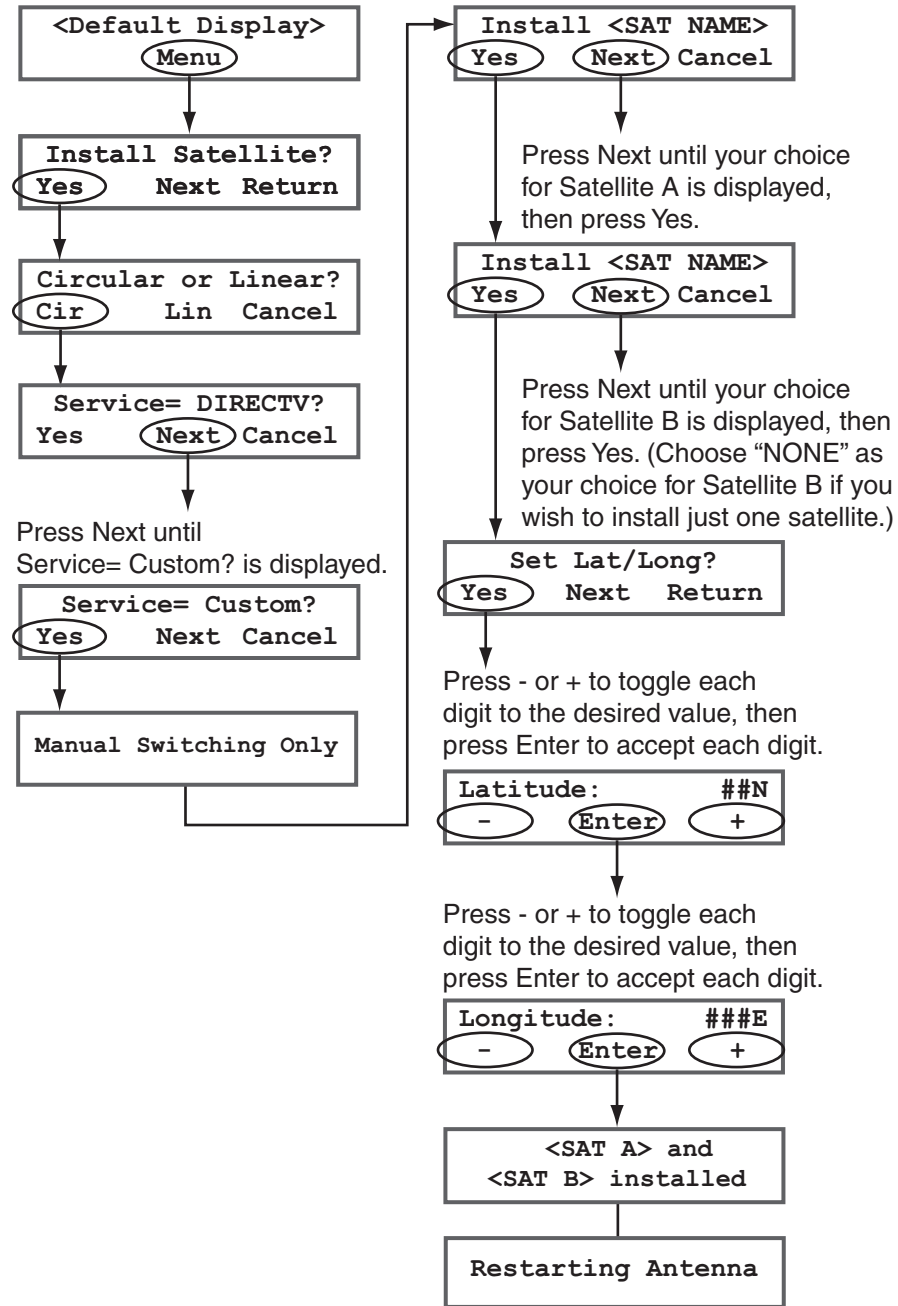

European Tri-Sat Mode Setup

This section explains how to configure the TracVision system to track three satellites within predefined linear satellite groups for use in European locations (see Figure 3-22). For operation instructions, refer to “Changing Channels and Switching Between Satellites (Linear Versions)” on page 21.

Figure 3-22 European Tri-Sat Groups - Satellites/TracVision Position

Group Name	Satellites	Position
Europe WB	Hotbird WB	A
	Astra 1	B
	Astra 2S	C
Europe	Hotbird	A
	Astra 1	B
	Astra 2S	C
Scandinavia	Hotbird WB	A
	Sirius	B
	Thor	C

NOTE: To enable automatic switching, the receiver must be set up to match the TracVision system's satellite position settings (A, B, or C). Refer to “Linear Receiver Configuration” on page 25 for more information.

Step 1 - Configure the European Tri-Sat Group

Use the flowchart in Figure 3-23 on page 49 if you need to configure the TracVision system for European Tri-Sat Mode.

NOTE: Be sure to record the skew angle (the average skew for all three satellites) that is displayed during this procedure. You will need this information to adjust the TracVision system's skew angle. See “Adjusting the Skew Angle (Linear Versions)” on page 31 for more information on setting the skew angle.

Figure 3-23 Configuring European Tri-Sat Mode

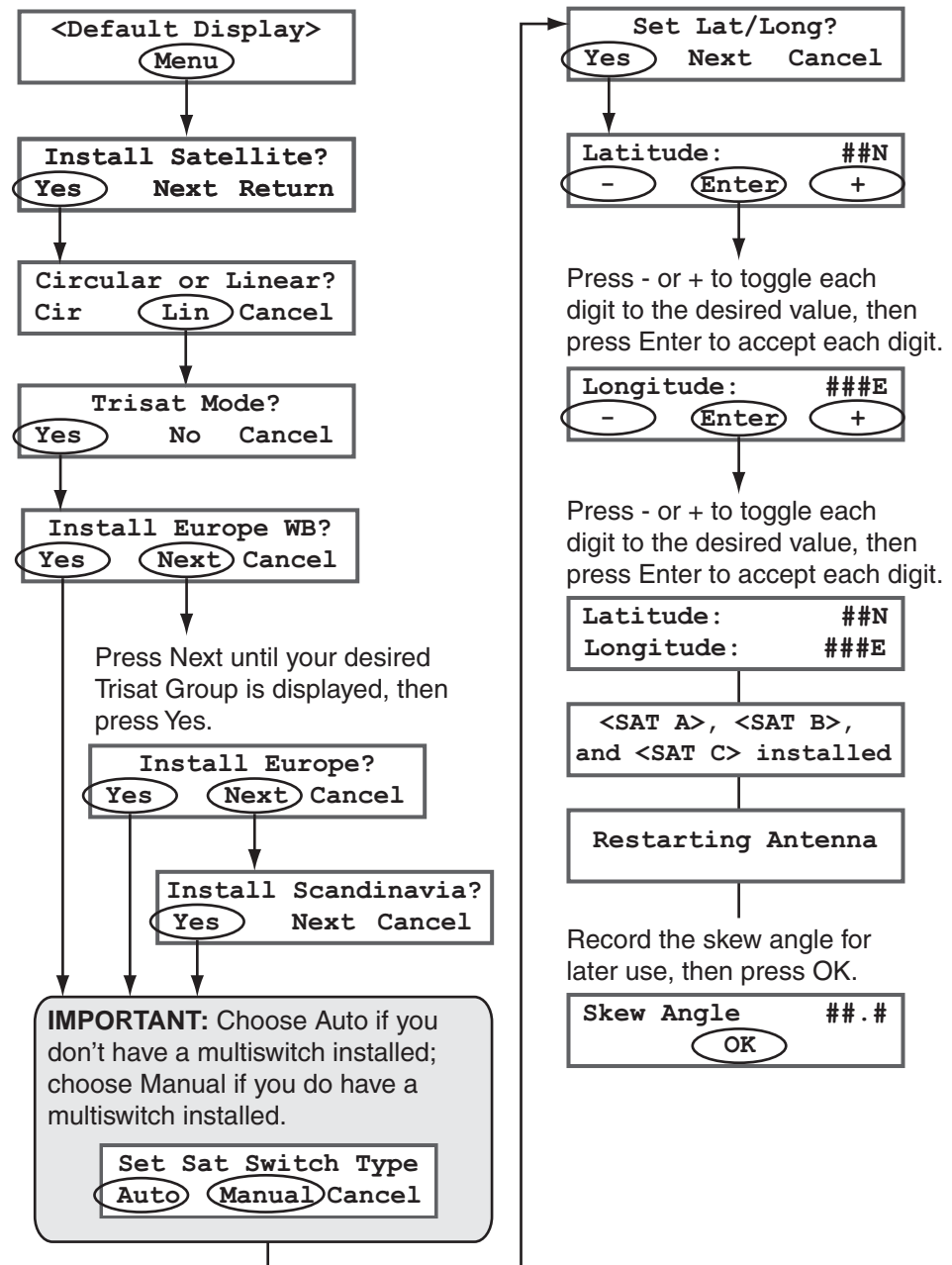

Step 2 - Adjust the LNB Skew Angle

Now that you have installed the desired Tri-Sat group and recorded the skew angle for the Tri-Sat group, you need to adjust the antenna's LNB skew angle to optimize signal reception. Follow the instructions in "Adjusting the Skew Angle (Linear Versions)" on page 31 to adjust the skew angle.

Linear Dual-Sat Mode Setup

This section explains how to configure the TracVision system to track any two satellites from the antenna's linear satellite library (shown in Figure 3-24). For operation instructions, refer to "Changing Channels and Switching Between Satellites (Linear Versions)" on page 21.

Figure 3-24 Linear Satellite Library

Satellite Location	Satellite	Installation Name
26.0° E	Arabsat	ARABSAT
19.2° E	Astra 1	ASTRA1
28.2° E	Astra 2N	ASTRA2N
28.2° E	Astra 2S	ASTRA2S
7.0° E	Eutelsat W3A	EUTEL_W3A
30.0° W	Hispasat	HISPASAT
13.0° E	Hotbird	HOTBIRD
13.0° E	Hotbird WB	HOTBIRDWB
7.0° W	Nilesat	NILESAT
160.0° E	Optus D1	OPTUSD1*
156.0° E	Optus C1	OPTUSC1
58.0°W	Pas 9	PAS_9
110.5° E	Sinosat 1	SINOSAT*
5.0° E	Sirius	SIRIUS
0.8° W	Thor	THOR
42.0° E	Turksat 1C	TURKSAT1C

***NOTE:** Reception of these satellites requires special hardware. Please contact your local KVH-authorized dealer/distributor or KVH Technical Support for details.

Step 1 - Configure the Satellites

Use the flowchart in Figure 3-25 to configure the TracVision system for linear Dual-Sat Mode.

NOTE: Be sure to record the skew angle (the average skew for both satellites) reported during this procedure. You will need this information to adjust the TracVision system's skew angle.

Figure 3-25 Configuring Linear Dual-Sat Mode

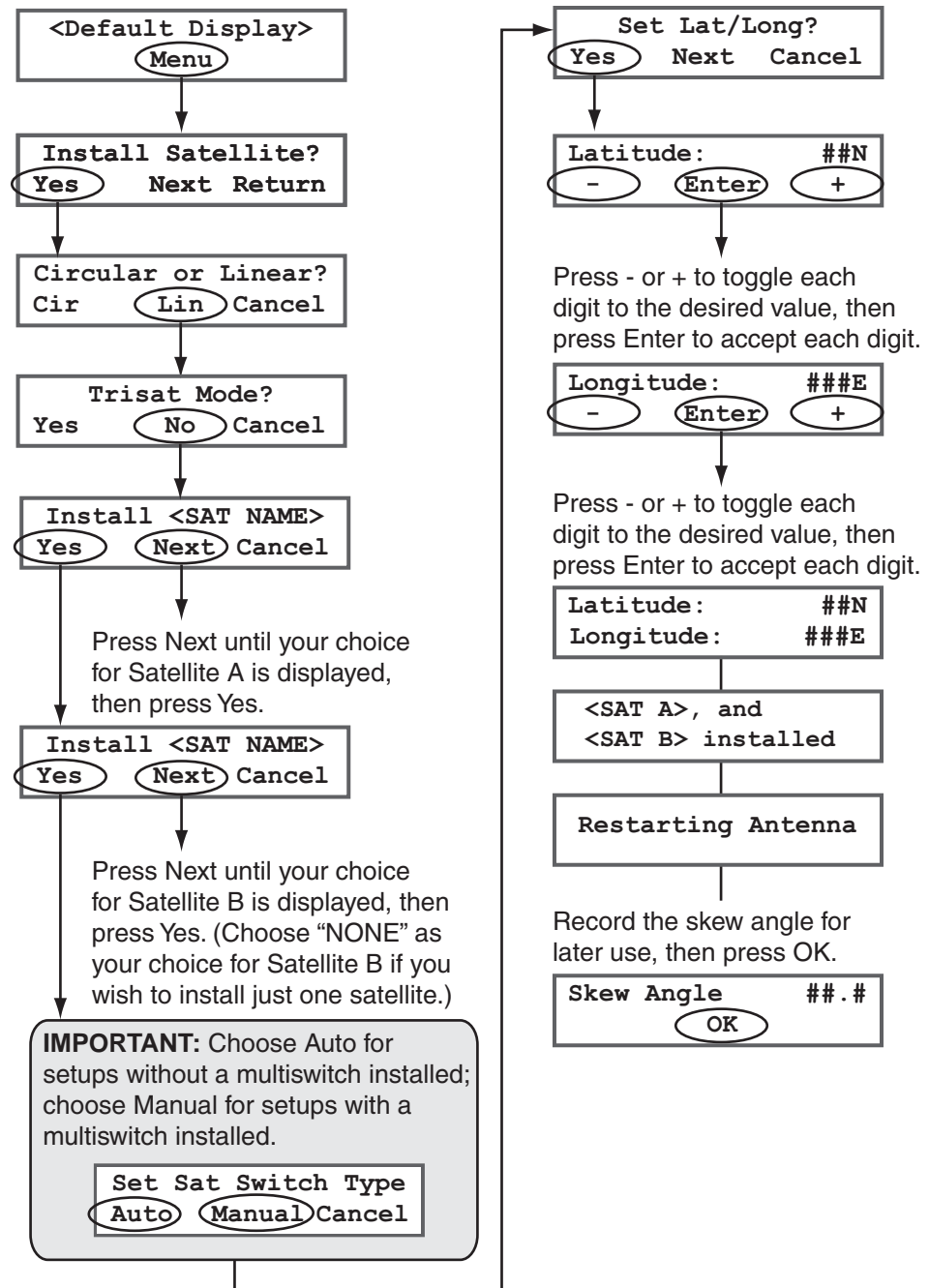

Step 2 - Adjust the LNB Skew Angle

Now that you have installed the desired satellites and recorded the skew angle, you need to adjust the antenna's LNB skew angle to optimize signal reception. Follow the instructions in "Adjusting the Skew Angle (Linear Versions)" on page 31 to adjust the skew angle.

NOTE: To enable automatic satellite switching, the receiver must be set up to match the TracVision system's satellite settings. Refer to "Linear Receiver Configuration" on page 25 for more information.

Selecting Automatic or Manual Satellite Switching

When your TracVision system was configured, the satellite switching method (automatic or manual) was also selected. However, you can use the flowchart in Figure 3-26 to change the satellite switching method for your selected service, if desired.

NOTE: While most TracVision configurations support automatic switching, Custom Dual-Sat configurations and any configurations with a multiswitch installed require manual switching. For more information on satellite switching options for your selected configuration, refer to the applicable service setup instructions in this chapter.

Figure 3-26 Setting the Satellite Switching Method

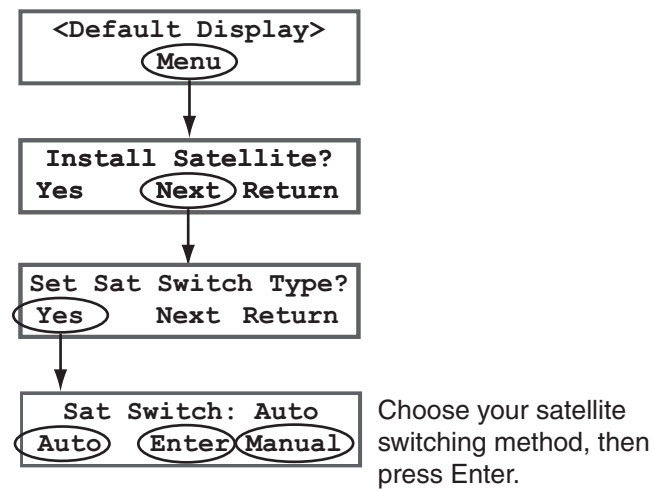

Resetting to Factory Default Settings

Use the flowchart in Figure 3-27 if you wish to reset the TracVision system to the factory default satellite service (DIRECTV Dual-Sat Mode) and LCD brightness settings.

Figure 3-27 Resetting to Factory Default Settings

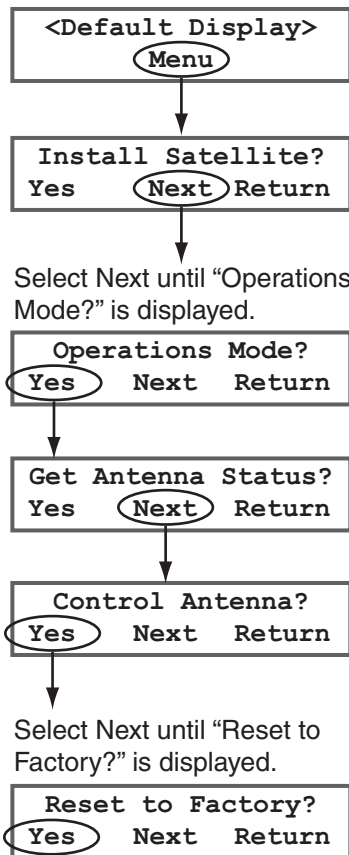

Restarting the TracVision System

Use the flowchart in Figure 3-28 if you wish to restart the TracVision system.

Figure 3-28 Restarting the TracVision System

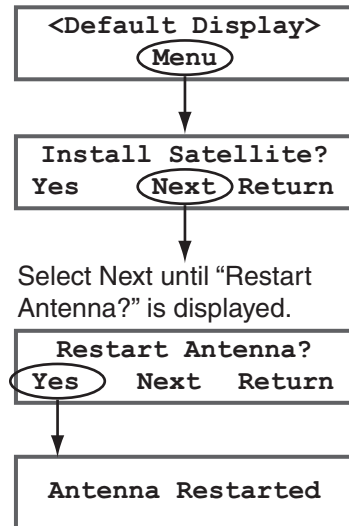



4. Troubleshooting

This chapter identifies potential basic problems along with their possible causes and solutions. It also explains how to get technical support.

Contents

- Five Simple Checks 59
- Troubleshooting Matrix..... 60
- Causes and Remedies for Operational Issues 61
- Technical Support..... 65





Five Simple Checks

If you are experiencing a problem receiving satellite TV with your TracVision system, perform the five simple checks below.

***TIP:** You can also try resetting the satellite TV receiver. Turn off and unplug the receiver, wait one minute, then plug it back in and turn it back on.*

Can the antenna see the satellite?

The antenna requires an unobstructed view of the sky to receive satellite TV signals. Common causes of blockage include trees, buildings, bridges, and mountains.

Is there excessive dirt or moisture on the antenna dome?

Dirt buildup or moisture on the dome can reduce satellite reception. Clean the exterior of the dome periodically.

Is it raining heavily?

Heavy rain or snow can weaken satellite TV signals. Reception should improve once the inclement weather subsides.

Is everything turned on and connected properly?

Make sure your TV and receiver are both turned on and set up for the satellite input. Finally, check any connecting cables to ensure none have come loose.

(Linear Versions Only) Is the antenna's LNB set to the correct skew angle?

To optimize reception, the antenna's LNB needs to be set to the correct skew angle for the satellite(s) you want to track. See "Adjusting the Skew Angle (Linear Versions)" on page 31 for details.

Troubleshooting Matrix

The troubleshooting matrix in Figure 4-1 identifies potential operational symptoms and their causes and remedies. “Causes and Remedies for Operational Issues” on page 61 contains detailed information on the causes and remedies listed below.

Figure 4-1 Troubleshooting Matrix

SYMPTOM	CAUSES AND REMEDIES										
	Receiver fault or improper receiver configuration	Satellite coverage issue	Satellite signal blocked	Radar interference	Satellite frequency	Vessel turning during data changed	Insufficient power	Improper wiring	Loose RF connectors	Type of multiswitch used	Cable unwrap
Antenna non-functional							x	x			
Antenna not switching satellites	x	x	x				x	x	x	x	
No picture on TV set	x	x	x	x	x			x	x	x	
Certain channels do not work	x	x	x		x		x	x	x		
Intermittent picture for short intervals		x	x	x		x			x	x	x
System works at dock but not on the move			x			x					
System will not find satellite	x	x	x	x	x	x	x	x	x	x	
Snowy television picture	x						x	x	x		
Pixelating television picture	x	x	x	x		x	x	x	x		



Causes and Remedies for Operational Issues

This section addresses the most common operational issues that can affect the performance of the TracVision M5/M7 system. If your TracVision system requires service, you can visit any KVH-authorized dealer or distributor for assistance. To find a KVH-authorized dealer near you, visit www.kvh.com/wheretogetservice.

Receiver Fault or Improper Receiver Configuration

Receiver Fault

Your satellite TV receiver might be set up incorrectly or defective. First check the receiver's configuration to ensure it is set up for the desired programming. In the case of a faulty receiver, refer to your selected receiver's user manual for service and warranty information.

Improper Receiver Configuration (Linear Versions Only)

To enable automatic satellite switching, the receiver(s) must be set up for the same satellites, and in the same order, they are set up in the antenna.

***NOTE:** Linear TracVision systems with a multiswitch installed require switching satellites using the MCP, which does not require receiver configuration.*

TracVision Satellite	Receiver Satellite	DiSEqC Setting
Satellite A	Alternative 1 or A	DiSEqC 1
Satellite B	Alternative 2 or B	DiSEqC 2
Satellite C	Alternative 3 or C	DiSEqC 3

Satellite Coverage Issue

Television satellites are located in fixed positions above the Earth's equator and beam TV signals down to certain regions of the planet (not worldwide). To receive TV signals from a satellite, you must be located within that satellite's unique coverage area.

TIP: For your convenience, KVH provides links to several websites that offer satellite coverage information. Simply visit our website at www.kvh.com/footprint.

Figure 4-2 Location and Coverage Area of DIRECTV 101 Satellite



Satellite Signal Blocked

Since TV satellites are located above the equator, the TracVision antenna must have a clear view of the sky to receive satellite TV signals. Anything that stands between the antenna and the satellite can block the signal, resulting in lost reception. Common causes of blockage include boat masts, trees, buildings, and bridges. Heavy rain, ice, or snow might also temporarily interrupt satellite signals.

Figure 4-3 Example of Satellite Blockage

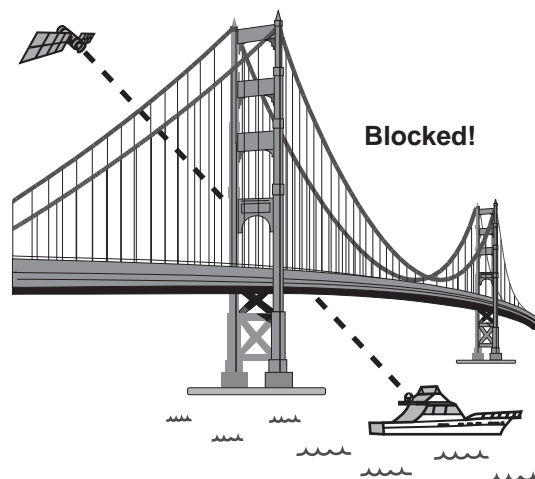



Radar Interference

The TracVision M5/M7 antenna must be kept out of line with nearby radars, as their energy levels might overload the antenna's front-end circuits. Refer to the TracVision M5/M7 Installation Guide for details, or visit any KVH-authorized dealer or distributor for assistance. To find a KVH-authorized dealer near you, visit www.kvh.com/wheretogetservice.

Satellite Frequency Data Changed

If some channels work, while one or more other channels do not, or if the antenna cannot find the selected satellite, the satellite's frequency data might have changed. You can visit any KVH-authorized dealer or distributor for assistance. To find a KVH-authorized dealer near you, visit www.kvh.com/wheretogetservice.

Vessel Turning During Startup

If you turn the vessel during the first minute after system startup, the gyro calibration that occurs during startup might be invalid, causing the TracVision M5/M7 system to track improperly. To solve this problem, simply turn off the TracVision M5/M7 system for at least ten seconds. Then turn on the TracVision system, ensuring the vessel is either motionless or traveling in a straight line for the first minute after startup.

Insufficient Power

If the power cable to the antenna unit is more than 50 ft (15 m) long, the power level can decrease over the length of the cable, resulting in a voltage level at the antenna that is too low to power the system. Refer to the TracVision M5/M7 Installation Guide for details on supplying adequate power to the antenna, or visit any KVH-authorized dealer or distributor for assistance. To find a KVH-authorized dealer near you, visit www.kvh.com/wheretogetservice.

Improper Wiring

If the system has been improperly wired, the antenna will not operate correctly. Refer to the TracVision M5/M7 Installation Guide for complete system wiring information, or visit any KVH-authorized dealer or distributor for assistance. To find a KVH-authorized dealer near you, visit www.kvh.com/wheretogetservice.

Loose RF Connectors

KVH recommends periodically checking the system's cable connections. A loose RF connector can reduce signal quality or prevent automatic satellite switching using the receiver's remote control. Refer to the TracVision M5/M7 Installation Guide for complete system wiring information, or visit any KVH-authorized dealer or distributor for assistance. To find a KVH-authorized dealer near you, visit www.kvh.com/wheretogetservice.

Type of Multiswitch Used

If your TracVision system's configuration requires a multiswitch, an active (powered) multiswitch must be used to ensure proper antenna performance. Refer to the wiring diagrams in Appendix C on page 79 for detailed information.

Cable Unwrap

If your vessel makes several consecutive circles in the same direction, the antenna will rotate 720° before reaching the end of its internal cable. If this occurs, the system will automatically unwrap the cable by quickly rotating the antenna dish in the opposite direction. During this time, your TV picture will freeze momentarily.

Technical Support

The TracVision M5/M7 antenna is a sophisticated electronic device. KVH-authorized technicians have the specialized tools and expertise necessary to diagnose and repair a system fault. Therefore, if you experience any operating problem or require technical assistance, please call or visit your local authorized TracVision dealer or distributor. To find a KVH-authorized dealer near you, visit www.kvh.com/wheretogetservice.

If you need help finding an authorized technician, please contact KVH Technical Support:

North/South America, Australia:

Phone: +1 401 847-3327

E-mail: techs@kvh.com

(Mon.-Fri., 9 am-6 pm ET, -5 GMT)

(Sat., 9 am-2 pm ET, -5 GMT)

Europe, Middle East, Asia:

Phone: +45 45 160 180

E-mail: support@kvh.dk

(Mon.-Fri., 8 am-4:30 pm, +1 GMT)

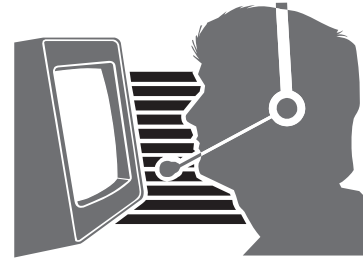

Please have your antenna serial number handy before you call (see “Displaying the Antenna Serial Number” on page 74 for more information).



Appendix A Advanced Settings and Functions

This appendix contains information on advanced settings and functions.
This information should only be utilized by KVH-authorized technicians.

Contents

Manually Control the Antenna	69
Updating Satellite Frequency Data	70
Configuring Satellite Settings	72
Displaying Software Version Information	73
Displaying the Antenna Serial Number	74

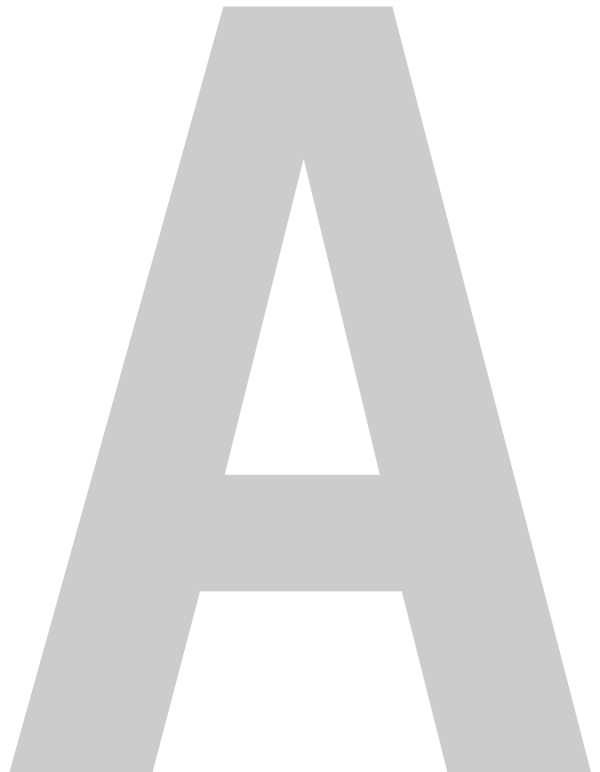

Manually Controlling the Antenna

Use the flowchart in Figure A-1 if you wish to control the antenna manually.

NOTE: If you are performing this procedure as part of the satellite frequency scan update procedure, be sure to select "NO" at the "Make Antenna Track?" screen.

NOTE: Azimuth is referenced to forward, not a true compass heading.

TIP: Once you have finished positioning the antenna, the system will revert to automatic control.

Figure A-1 Manually Controlling the Antenna

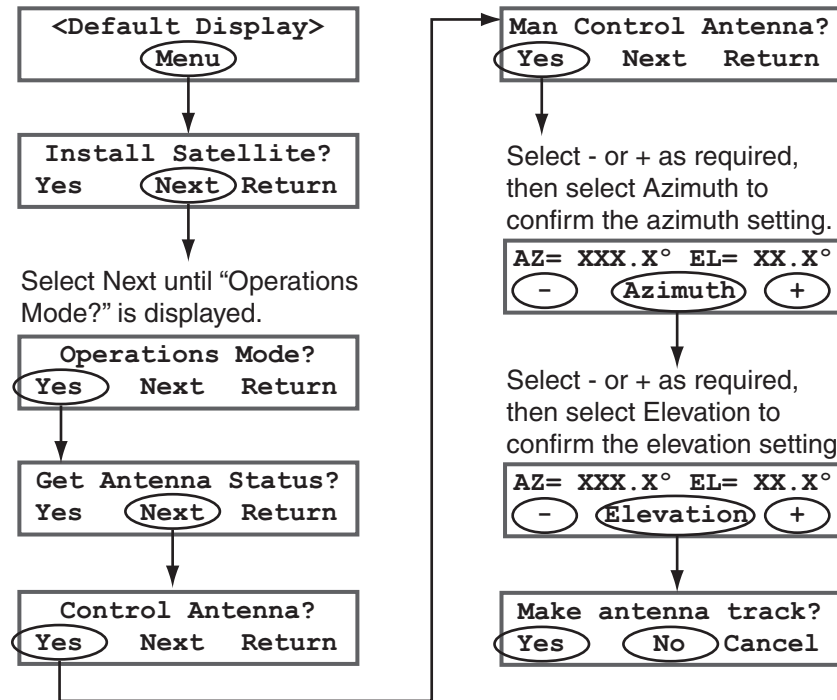

Updating Satellite Frequency Data

If the antenna is unable to find a satellite, or if you are unable to receive certain channels, the satellite's frequency data might have changed. The satellite frequency scan feature allows you to update the frequency data of any satellite stored in the system's library.

With the desired satellite, band, and polarization selected, the system will automatically search for the frequency with the strongest signal. The system will then update that satellite's programmed data with the new frequency (and associated network ID) and store it in the satellite library.

You will need to enter the following information:

- Symbol rate
- FEC code

TIP: You can find satellite information on the web at www.lyngsat.com or www.satcodx.com (neither website is affiliated with KVH).

To update the satellite frequency data, follow the steps below.

IMPORTANT!

The vessel must remain stationary throughout this procedure.

1. Track the satellite you wish to update by choosing a valid polarization/band.
2. Set your satellite receiver to signal meter mode. Refer to your selected receiver's user manual for details.
3. Ensure your TV signal meter indicates that you have a strong signal.
4. Using the receiver, select the desired polarization and band you wish to update. Refer to your selected receiver's user manual for details.

- Use the flowchart in Figure A-2 to scan the frequency data of the selected satellites.

TIP: If you know the satellite configuration data, you can configure the satellite without scanning frequency data (see “Configuring Satellite Settings” on page 72).

TIP: Scanning satellite frequencies might take up to 10 minutes.

Figure A-2 Scanning Frequency Data

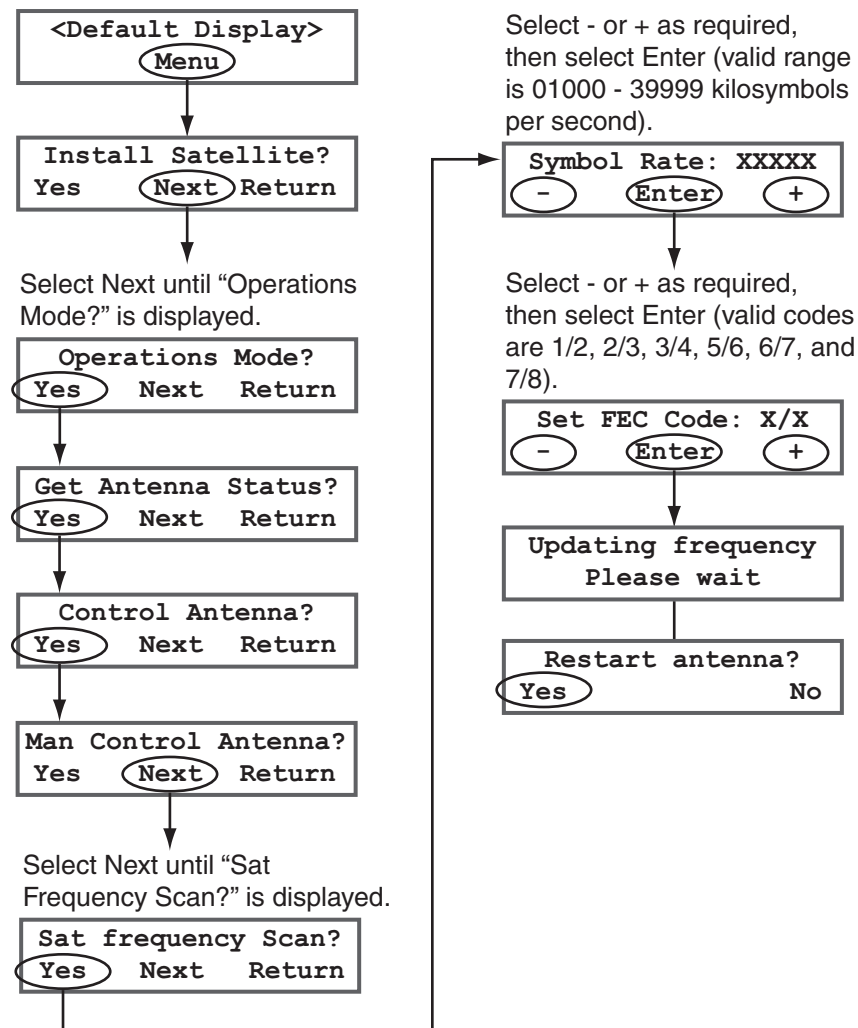

Configuring Satellite Settings

Use the flowchart in Figure A-3 to configure one of the satellites selected for tracking.

TIP: Linear satellites use the following polarization/band combinations: vertical high, vertical low, horizontal high, and horizontal low. Circular satellites use the following polarization/band combinations: right and left.

Figure A-3 Configuring Satellite Settings

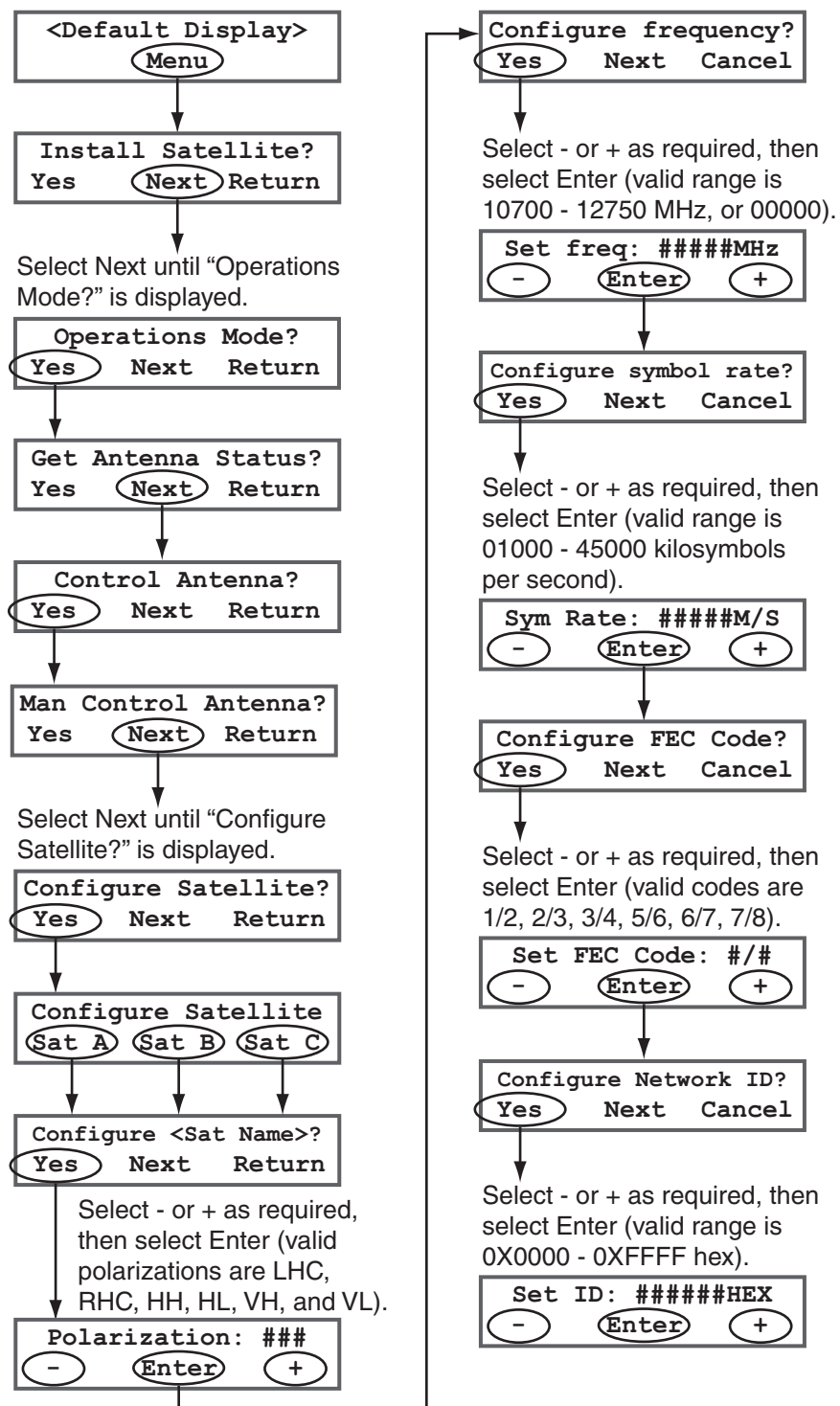

Displaying Software Version Information

Use the flowchart in Figure A-4 if you wish to display software version information.

Figure A-4 Displaying Software Version Information

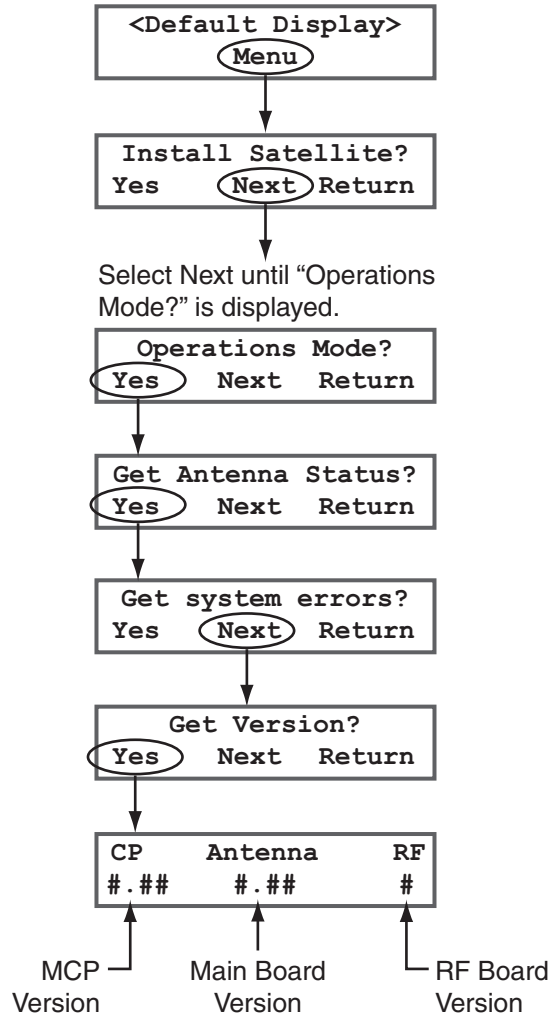

Displaying the Antenna Serial Number

Use the flowchart in Figure A-5 if you wish to view the antenna serial number.

Figure A-5 Displaying Antenna Serial Number

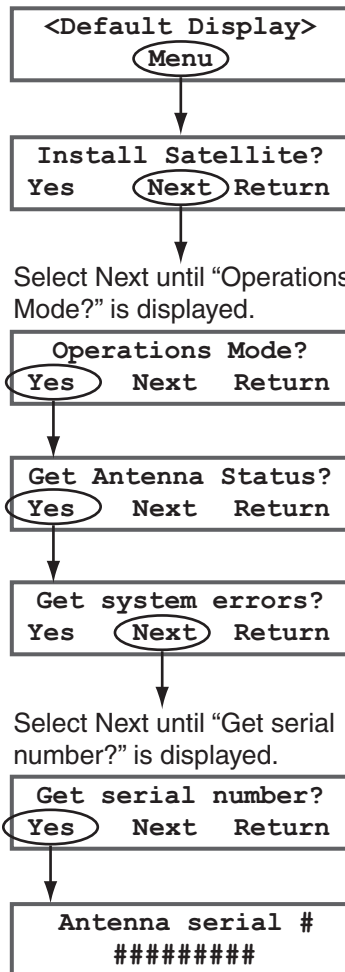



Appendix B Position Grids

This appendix contains European and North American position grids for determining your approximate latitude and longitude.

Contents

European Position Grid 77
North American Position Grid 78



European Position Grid

If you wish to determine your approximate latitude and longitude, use the position grid and table in Figure B-1.

Figure B-1 Approximate Latitude and Longitude

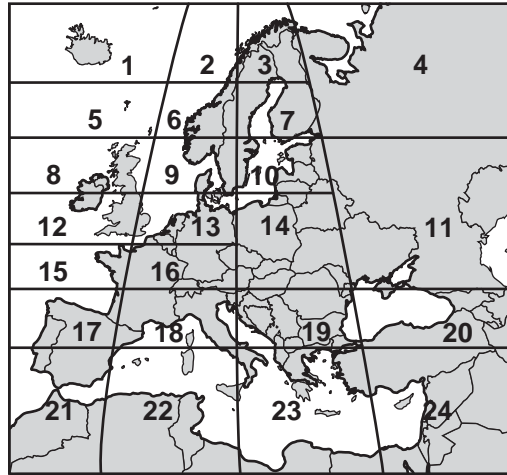

Grid #	Latitude	Longitude
1	67° N	7° W
2	67° N	7° E
3	67° N	22° E
4	65° N	45° E
5	63° N	7° W
6	63° N	7° E
7	63° N	22° E
8	57° N	7° W
9	57° N	7° E
10	57° N	22° E
11	55° N	40° E
12	53° N	7° W
13	53° N	7° E
14	50° N	22° E
15	47° N	7° W
16	47° N	7° E
17	43° N	7° W
18	43° N	7° E
19	43° N	22° E
20	43° N	37° E
21	36° N	7° W
22	36° N	7° E
23	36° N	22° E
24	36° N	37° E

North American Position Grid

If you wish to determine your approximate latitude and longitude, use the position grid and table in Figure B-2.

Figure B-2 Approximate Latitude and Longitude

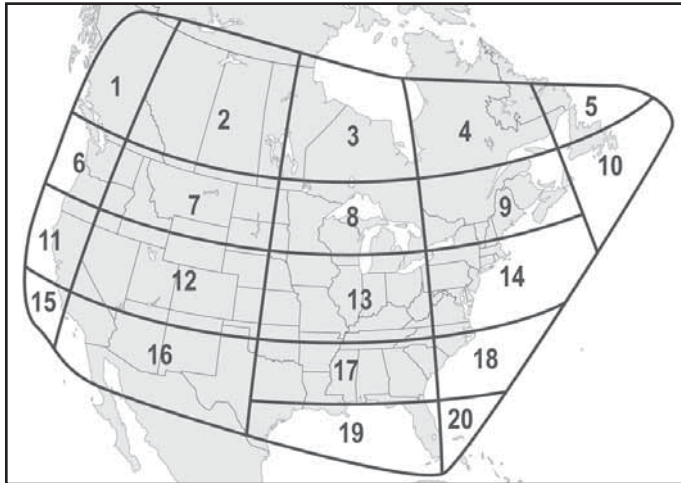

Grid #	Latitude	Longitude
1	55° N	125° W
2	55° N	110° W
3	55° N	90° W
4	55° N	70° W
5	55° N	55° W
6	45° N	125° W
7	45° N	110° W
8	45° N	90° W
9	45° N	70° W
10	45° N	50° W
11	40° N	125° W
12	40° N	110° W
13	40° N	90° W
14	40° N	70° W
15	32° N	125° W
16	32° N	110° W
17	32° N	90° W
18	32° N	75° W
19	27° N	83° W
20	27° N	78° W



Appendix C

Wiring Diagrams

This appendix provides receiver wiring diagrams for basic configurations. Wiring diagrams vary according to the number of receivers installed and the TracVision system configuration (circular/linear and dual/quad-output). For installation instructions, refer to the TracVision M5/M7 Installation Guide.

Contents

Wiring Diagram for One or Two Receivers	81
Wiring Diagram for Three or Four Receivers (Circular Versions)	82
Wiring Diagram for Three or Four Receivers (Linear Quad-output Versions).....	83

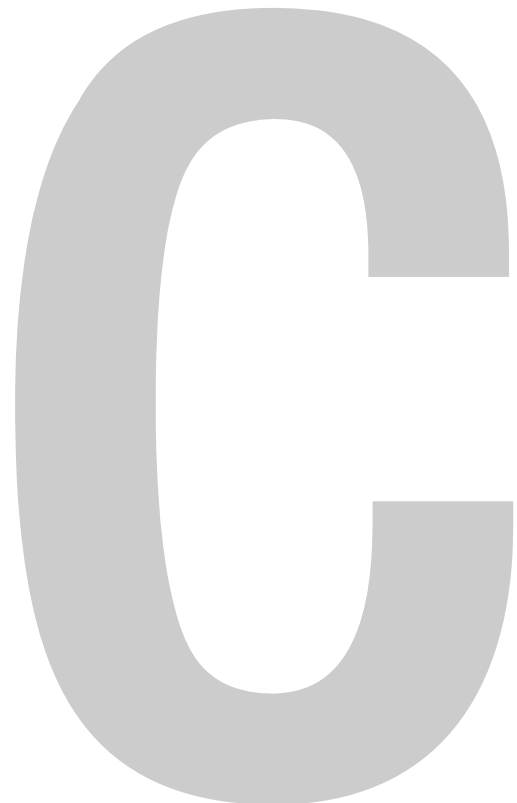

Wiring Diagram for One or Two Receivers

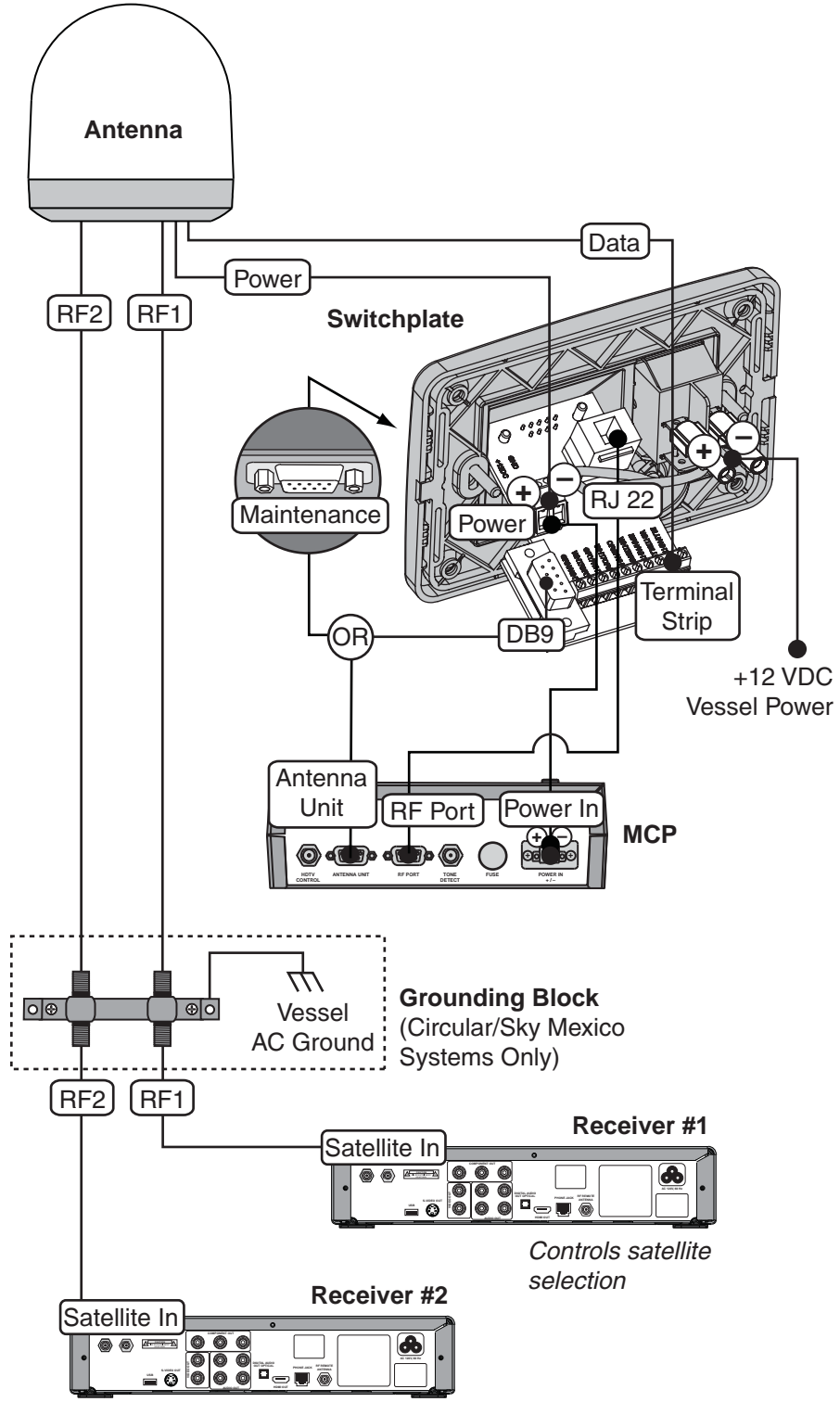

Wiring Diagram for Three or Four Receivers (Circular Versions)*

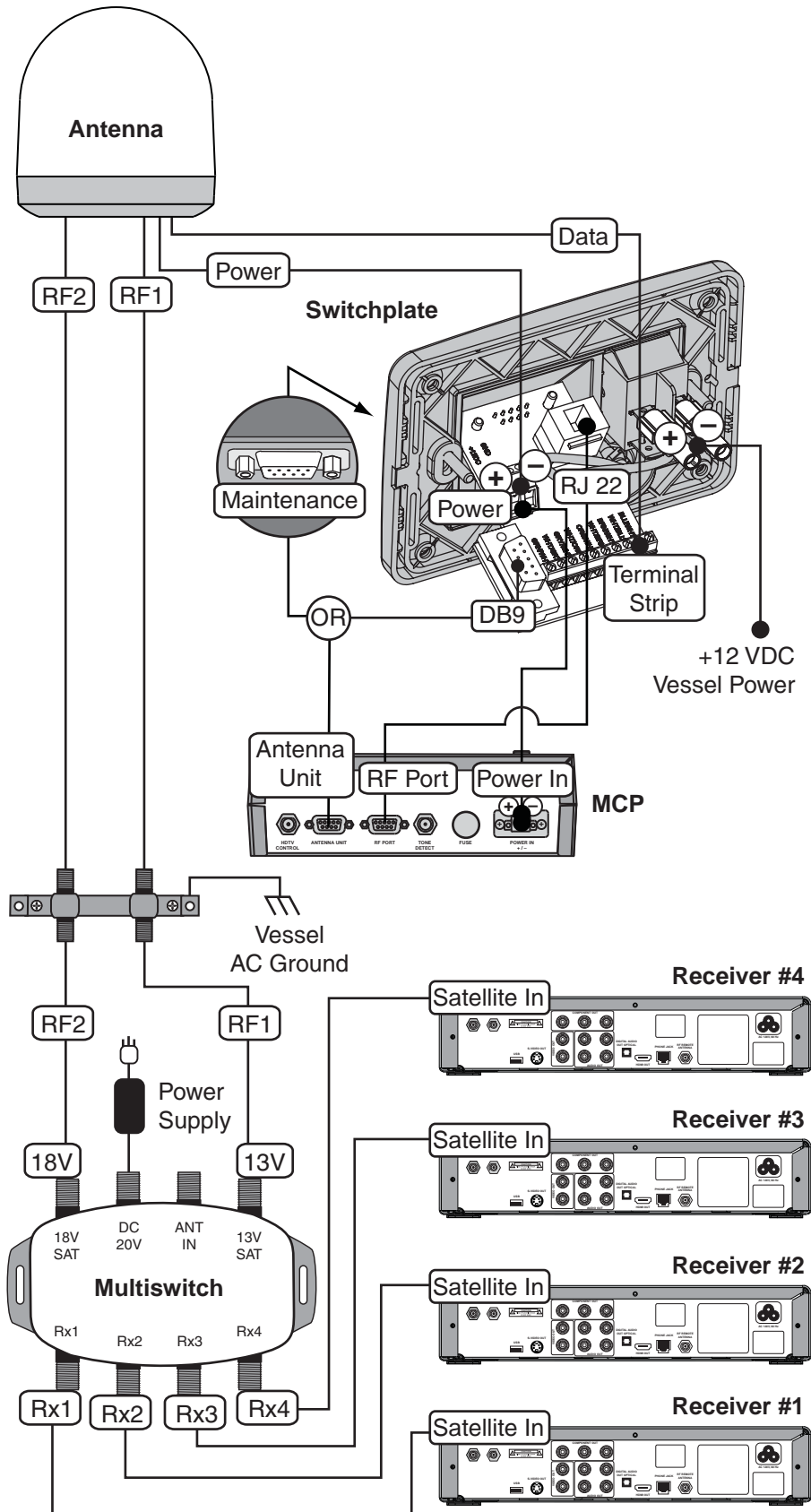

*NOTE: Only the Eagle Aspen multiswitch (KVH Part #72-0310) is approved for this configuration.

Wiring Diagram for Three or Four Receivers (Linear Quad-output Versions)

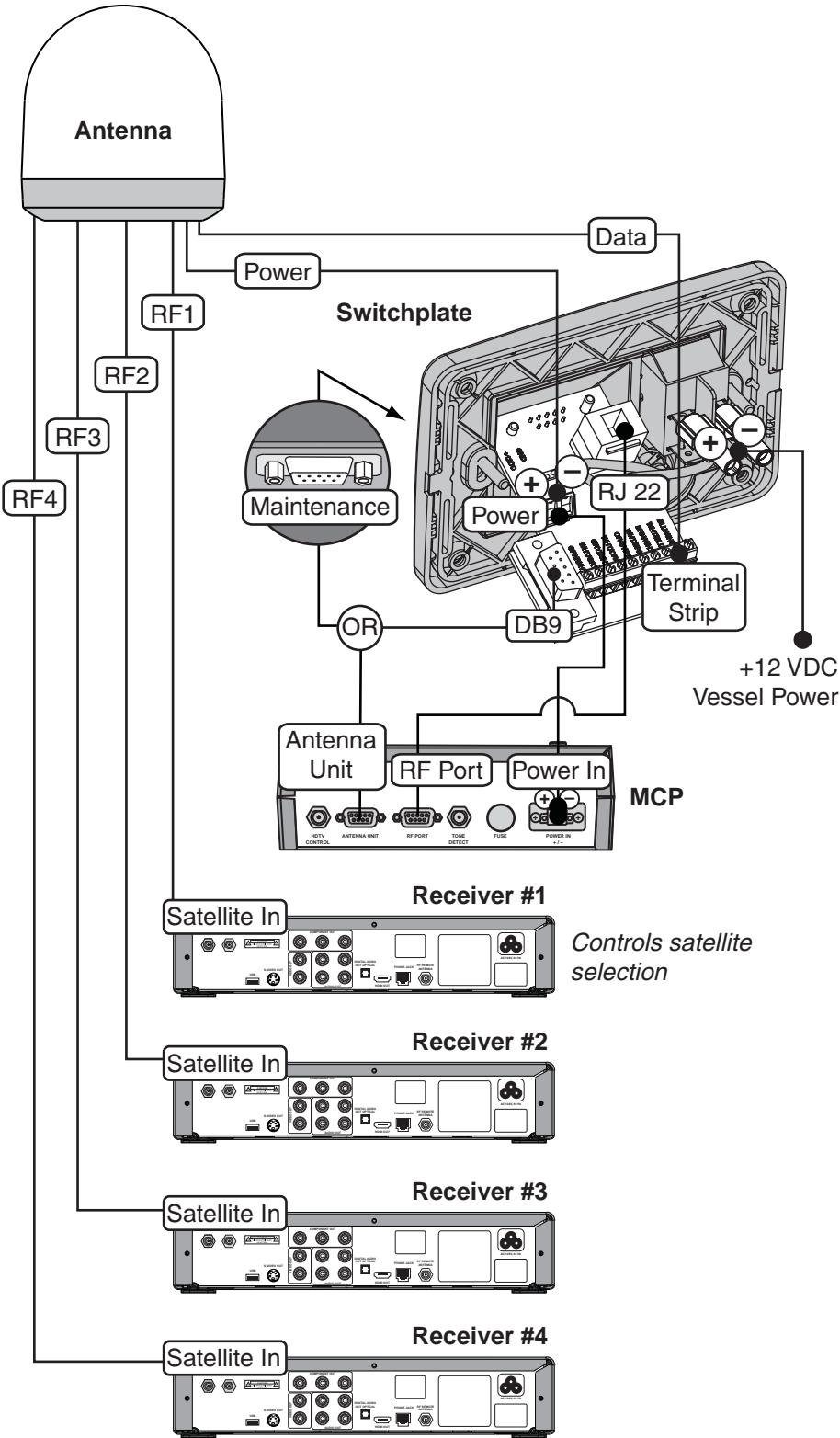

Linear Quad-output Versions Only

NOTE: If you wish to connect more than four receivers, you will need to install an active (powered) multiswitch, such as Spaun model 5602NF. You can purchase this multiswitch from KVH (KVH Part #19-0413).



www.kvh.com



KVH Industries A/S
EMEA Headquarters
Kokkedal, Denmark
Tel: +45 45 160 180 Fax: +45 45 160 181
E-mail: info@emea.kvh.com

KVH Industries, Inc.
World Headquarters
Middletown, RI U.S.A.
Tel: +1 401 847 3327 Fax: +1 401 849 0045
E-mail: info@kvh.com

KVH Industries Pte Ltd.
Asia-Pacific Headquarters
Singapore
Tel: +65 6513 0290 Fax: +65 6472 3469
E-mail: info@apac.kvh.com