

KVH Industries, Inc.

TracVision® M5/M7

GyroTrac™ Configuration



User's Guide

PLEASE READ!

Important Addendum to the Product Manuals

This addendum applies to systems having the following serial number or later:

M5: 131000890

M7: 131000307

Your TracVision[®] M5/M7 antenna is equipped with a new RF7 board, which expands the satellite tracking capabilities of the system.

Supported Decoding Types

In addition to legacy QPSK DSS and DVB satellite signals, the RF7 board adds the capability to decode the following types of signals:

- Turbo QPSK (DISH DVB-S2)
- QPSK DCII (DigiCipher 2)
- Turbo 8PSK (DISH DVB-S2)
- LDPC 8PSK (standard DVB-S2)
- LDPC QPSK (standard DVB-S2)

The procedure for configuring user-defined satellites has been updated to include these new decoding types. Refer to the attached application note for details.

Supported FEC Codes

The RF7 board adds the capability to decode satellite signals that use the following FEC (forward error correction) codes:

- 3/5
- 4/5
- 8/9
- 5/11
- 9/10

The procedure for configuring user-defined satellites has been updated to include these new FEC codes. Refer to the attached application note for details.

NOTE: The RF7 board also continues to support the following FEC codes: 1/2, 2/3, 3/4, 5/6, 6/7, 7/8, and 99 (auto).

Signal Quality

The RF7 board now reports SNR (signal-to-noise ratio) rather than BER (bit error rate) to indicate the quality of the received satellite signal.

Control Panel Configuration: To view the SNR on the MCP front panel, select *Operations Mode > Get Antenna Status > Get SNR*.

GyroTrac Configuration: To view the SNR on the ADCU, select *Get Antenna Status > Get SNR*.

Switchplate Configuration: To view the SNR on your laptop connected to the antenna, enter the **@SNR** command in either HyperTerminal or the Flash Update Wizard.

Satellite Library

The following satellites have been added to the RF7 board's satellite library:

Satellite Name	Satellite Position	Installation Name	LNB Type
Astra 3	23.5° E	ASTRA3	Linear

The following satellite data have been updated in the RF7 board's satellite library:

Satellite Name	Satellite Position	Installation Name	LNB Type
Optus D1	160.0° E	OPTUS_D1	Linear
Optus C1	156.0° E	OPTUS_C1	Linear

Configuring User-Defined Satellite(s)

To configure a user-defined satellite, you will need to enter satellite tracking information into the antenna. This procedure requires a Windows-based PC with the most current version of the KVH Flash Update Wizard installed. You will use the Flash Update Wizard to enter the following information:

- Satellite name
- Satellite longitudinal position
- Transponder information for all applicable combinations of polarization/band:
 - Frequency
 - Symbol rate
 - FEC code
 - Network ID
- Decoding type

Circular satellites use the following polarizations:

- Left
- Right

Linear satellites use the following polarizations and bands:

- Vertical high (11700 – 12750 MHz)
- Vertical low (10700 – 11700 MHz)
- Horizontal high (11700 – 12750 MHz)
- Horizontal low (10700 – 11700 MHz)

NOTE: A 22 KHz tone must be present on the TracVision system's coaxial cable to enable switching to high band channels.

TIP: You can find satellite information on the web at www.lyngsat.com (not affiliated with KVH).

Step 1 – Connect Your PC to the TracVision System

Follow the instructions provided in the Flash Update Wizard's Help file to connect your PC to the TracVision system.

Step 2 – Define the Satellite(s)

Now you need to enter the following commands into the Flash Update Wizard's "Command Line" box.

NOTE: Variables are shown in *bold italics*.

1. Enter **HALT**.
2. Enter **DEBUGON**.
3. Using the table below, enter the following SATCONFIG command:

SATCONFIG,a,b,c,d,e

Field	Description
a	User-defined satellite stored in the antenna library: USER1 = User-defined Satellite 1 USER2 = User-defined Satellite 2
b	Longitude: 0-180
c	E (East) or W (West)
d	Decoding type: 0 = Turbo QPSK (DISH DVB-S2)* 1 = QPSK DCII (DigiCipher 2)* 2 = QPSK DTV (Legacy DSS) 3 = QPSK DVB (Legacy DVB) 4 = Turbo 8PSK (DISH DVB-S2)* 5 = LDPC 8PSK (Standard DVB-S2)* 6 = LDPC QPSK (Standard DVB-S2)*
e	Polarization: L = Linear C = Circular

* RF7 board required

Step 3 – Install the User-defined Satellite(s)

Follow the steps in the TracVision system's manual to select your new user-defined satellite(s) for tracking. Be sure to use the following installation names for your user-defined satellite(s):

Satellite	Installation Name
User-defined Satellite 1	USER1
User-defined Satellite 2	USER2

Step 4 – Configure the RF Tracking Parameters

Follow the steps below to set up the tracking parameters of the user-defined satellite(s).

1. Enter **@DEBUGON**.
2. Using the table below, enter the following **@SATCONFIG** command:

@SATCONFIG,a,b,c,d,e,f,g,h,i

Field	Description
a	User-defined satellite position stored in antenna library: A = satellite position A B = satellite position B
b	User-defined satellite stored in antenna library: 98 = User1 99 = User2
c	Frequency, MHz (00000 or 10700-12750)
d	Symbol rate, kilosymbols per second (10000-45000; 33000 max if DVB-S2)
e	FEC code: 12, 23, 34, 35*, 45*, 56, 67, 78, 89*, 51 (5/11)*, 91 (9/10)*, or 99 (auto)
f	Network ID, hexadecimal (0x####)
g	Polarization: V = Vertical H = Horizontal R = Right L = Left
h	LNB down conversion frequency: U = USA (DBS) (LO=11250 MHz) L = Low (LO=9750 MHz) H = High (LO=10600 MHz) G = Latin America (LO=10500 MHz) S = Sinosat (LO=11300 MHz)
i	Decoding type: 0 = Turbo QPSK (DISH DVB-S2)* 1 = QPSK DCII (DigiCipher 2)* 2 = QPSK DTV (Legacy DSS) 3 = QPSK DVB (Legacy DVB) 4 = Turbo 8PSK (DISH DVB-S2)* 5 = LDPC 8PSK (Standard DVB-S2)* 6 = LDPC QPSK (Standard DVB-S2)*

* RF7 board required

3. Repeat Step 2 for each applicable polarization/band shown below.

- Linear systems:
 - Vertical high
 - Vertical low
 - Horizontal high
 - Horizontal low
- Circular systems:
 - Right
 - Left

If your selected satellite does not have information for one or more of these transponder categories, you can enter the following default values instead:

Transponder Data	Default Value
Frequency	00000
Symbol rate	27500
FEC code	Same value as other transponders with valid data
Network ID	0x0000

4. Enter **ZAP**.
5. The antenna will restart. Wait two minutes for system startup.
6. Repeat this procedure if you wish to program a second user-defined satellite.

Example – Linear Satellite

The following is an example of programming the fictional “YOURSAT 7” as the USER1 user-defined satellite.

YOURSAT 7 AT 7°W, legacy DVB decoder, linear polarization

Transponder Data	Value
<i>Horizontal High</i>	
Frequency	11.966 GHz
Symbol rate	27500
FEC code	3/4
Network ID	2048 (dec) = 0x0800
<i>Vertical High</i>	
Frequency	11.823 GHz
Symbol rate	27500
FEC code	3/4
Network ID	2048 (dec) = 0x0800
<i>Vertical Low</i>	
No data listed	
<i>Horizontal Low</i>	
No data listed	

Based on the above information, you would enter the following commands:

```

HALT
DEBUGON
SATCONFIG,USER1,7,W,3,L
SATINSTALL,USER1,NONE
@DEBUGON
@SATCONFIG,A,98,11966,27500,34,0X0800,H,H,3
@SATCONFIG,A,98,11823,27500,34,0X0800,V,H,3
@SATCONFIG,A,98,00000,27500,34,0X0000,V,L,3
@SATCONFIG,A,98,00000,27500,34,0X0000,H,L,3
ZAP

```



Example – Circular Satellite

The following is an example of programming the fictional “YOURSAT 122” as the USER2 user-defined satellite.

YOURSAT 122 AT 122°W, standard DVB-S2 8PSK decoder, circular polarization

Transponder Data	Value
Right	
Frequency	12.225 GHz
Symbol rate	20000
FEC code	5/6
Network ID	4100 (dec) = 0x1004
Left	
Frequency	12.456 GHz
Symbol rate	20000
FEC code	5/6
Network ID	4100 (dec) = 0x1004

Based on the above information, you would enter the following commands:

```

HALT
DEBUGON
SATCONFIG,USER2,122,W,5,C
SATINSTALL,USER2,NONE
@DEBUGON
@SATCONFIG,A,99,12225,20000,56,0X1004,R,U,5
@SATCONFIG,A,99,12456,20000,56,0X1004,L,U,5
ZAP

```





Important Information About Your TracVision® M7 System with Auto Skew

Note: Not all TracVison M7 systems include Auto Skew. If you are unsure whether your linear TracVision M7 system includes automatic or manual skew adjustment, please refer to the documentation supplied with your system.

Congratulations! Your TracVision M7 system has Auto Skew capability, which provides automatic skew angle adjustment for your selected satellite(s), and an internal GPS antenna. These added features are not cited in the product manuals.

You Do Not Need to Adjust the LNB Skew Angle.

Your TracVision system includes an Auto Skew mechanism, which automatically adjusts the skew angle of the antenna's LNB. Therefore, disregard any instructions in the manuals that direct you to modify the LNB's skew angle. No manual adjustment is necessary.

TIP: For more information on how skew works, please refer to the TracVision M7 User's Guide.

You Do Not Need to Enter Your Latitude and Longitude.

Your TracVision M7 system includes a GPS antenna, which provides constantly updated location information to the TracVision system. Therefore, disregard any instructions in the manuals that direct you to manually enter the vessel's latitude and longitude.

TracVision M5/M7

GyroTrac Configuration

User's Guide

This user's guide provides all of the basic information you need to operate, set up, and troubleshoot the TracVision M5/M7 satellite TV antenna system. For detailed installation information, please refer to the TracVision M5/M7 Installation Guide.



Please direct questions, comments, or suggestions to:

KVH Industries, Inc.

50 Enterprise Center
Middletown, RI 02842-5279 USA
Tel: +1 401 847-3327
Fax: +1 401 849-0045
E-mail: info@kvh.com
Internet: www.kvh.com

KVH Europe A/S

Kokkedal Industripark 2B
2980 Kokkedal, Denmark
Tel: +45 45 160 180
Fax: +45 45 160 181
E-mail: info@kvh.dk
Internet: www.kvh.com

If you have any comments regarding this manual, please e-mail them to manuals@kvh.com. Your input is greatly appreciated!



KVH Part # 54-0419-01 Rev. D
© 2007-2009, KVH Industries, Inc., All rights reserved.
U.S. Patents Pending



TracVision and KVH are registered trademarks of KVH Industries, Inc.

The unique light-colored dome with dark contrasting base is a registered trademark of KVH Industries, Inc.

DVB (Digital Video Broadcasting) is a registered trademark of the DVB Project.

DIRECTV is an official trademark of DIRECTV, Inc.

DISH Network is an official trademark of EchoStar Communications Corporation.

ExpressVu is a property of Bell ExpressVu, a wholly owned subsidiary of Bell Satellite Services.

All other trademarks are the property of their respective owners.



Table of Contents

1	Introduction	
	Using this Manual	3
	System Overview	6
	Circular and Linear Versions.....	9
2	Operation	
	Receiving Satellite TV Signals	13
	Turning the System On/Off	14
	Changing Channels and Switching Between Satellites (Circular Versions)	15
	Changing Channels and Switching Between Satellites (Linear Versions).....	21
	Receiver Requirements	24
	ADCU Display Types.....	26
	Product Care	29
3	Settings	
	Manually Setting Latitude and Longitude	33
	Setting the LNB Skew Angle (Linear Versions Only)	34
	Connecting a PC	40
	DISH 1000 Setup.....	42
	Dual-Sat or Single Satellite Setups	46
	European Tri-Sat Mode Setup	52
	Setting Instant On Mode	55
	Setting Sleep Mode	56
	Adjusting Display Brightness.....	57
	Restarting the TracVision System.....	58

4	Troubleshooting	
	Five Simple Checks.....	61
	Error Messages.....	62
	Troubleshooting Matrix.....	64
	Causes and Remedies for Operational Issues.....	65
	Technical Support.....	69
A	Advanced Settings and Functions	
	Data Output Settings.....	73
	Setting the Heading Reference Source.....	77
	Manually Controlling the Antenna.....	78
	Updating Satellite Frequency Data.....	79
	Displaying the Calibration Score.....	81
	Displaying the Antenna Software Version.....	82
	Displaying the Antenna Serial Number.....	83
B	Recalibration	
	Recalibrating the System.....	87
	Setting the Sensor Offset Values.....	94
C	Receiver Wiring Diagrams	
	Wiring Diagram for One or Two Receivers.....	99
	Wiring Diagram for Three or Four Receivers (Circular Versions)*.....	100
	Wiring Diagram for Three or Four Receivers (Linear Quad-output Versions)*.....	101
D	ADCU Wiring Diagrams	
	ADCU Wiring Diagram (Required).....	105
	ADCU Wiring Diagram (Optional Equipment).....	106
E	Position Grids	
	European Position Grid.....	109
	North American Position Grid.....	110



1. Introduction

This chapter provides a basic overview of this manual and your TracVision system.

Contents

- Using this Manual 3
- System Overview 6
- Circular and Linear Versions..... 9

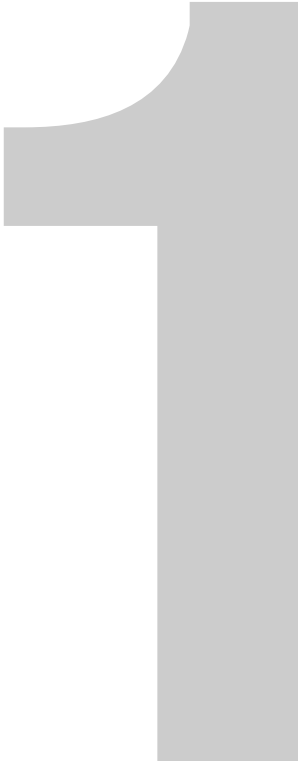



Using this Manual

This manual provides complete operation, setup, and troubleshooting information for your TracVision system, as well as wiring diagrams for various TracVision M5/M7 configurations.

Who Should Use This Manual

The **user** should refer to the “Operation” chapter to learn how to operate the system.

The **user**, **installer**, or **servicing technician** should refer to the “Settings” chapter for information on configuring the system and the “Receiver Wiring Diagrams” appendix for information on connecting additional receivers.

The **user** and/or **servicing technician** should refer to the “Advanced Settings and Functions” appendix for information on advanced settings and operational procedures.

The **user** and/or **servicing technician** should refer to the “Troubleshooting” chapter to help identify the cause of a system problem.

Notifications Used in this Manual

This manual uses the following notifications to call attention to important information:



CAUTION

This is a danger, warning, or caution notice. Be sure to read these carefully to avoid injury!

IMPORTANT!

This is an important notice. Be sure to read these carefully to ensure proper operation and configuration of your TracVision system.

NOTE: Notes contain useful information about system settings.

TIP: Tips contain helpful information, allowing you to get the most out of your TracVision system.

Typographical Conventions

This manual uses the following typographical conventions:

Text Example	Description
<SAT NAME> ###	Text in brackets or the pound sign (#) indicates a variable portion of the Advanced Digital Control Unit (ADCU) display
HALT	Bold text in capital letters indicates a command to be entered via a PC
<i>X</i>	Bold text in <i>italicized</i> capital letters indicates a variable portion of a command to be entered via a PC

ADCU (Advanced Digital Control Unit) Interface Conventions

When instructions indicate to select a specific ADCU menu option, press the ADCU button located directly beneath the menu option.

Figure 1-1 Example of ADCU Menu Option and Corresponding Button

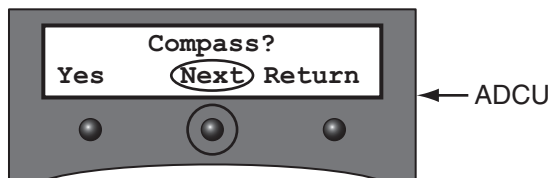



Related Documentation

In addition to this User's Guide, the following documents are provided with your TracVision system:

Document	Description
Installation Guide	Complete product installation instructions
Product Registration Form	Details on registering the product
Warranty Statement	Warranty terms and conditions
Contents List	List of every part supplied in the kit

System Overview

Your TracVision M5/M7 is a state-of-the-art, actively stabilized antenna system that delivers live satellite TV to your vessel's audio/video entertainment system. A basic system is illustrated below.

Figure 1-2 TracVision System Diagram (Typical Installation)

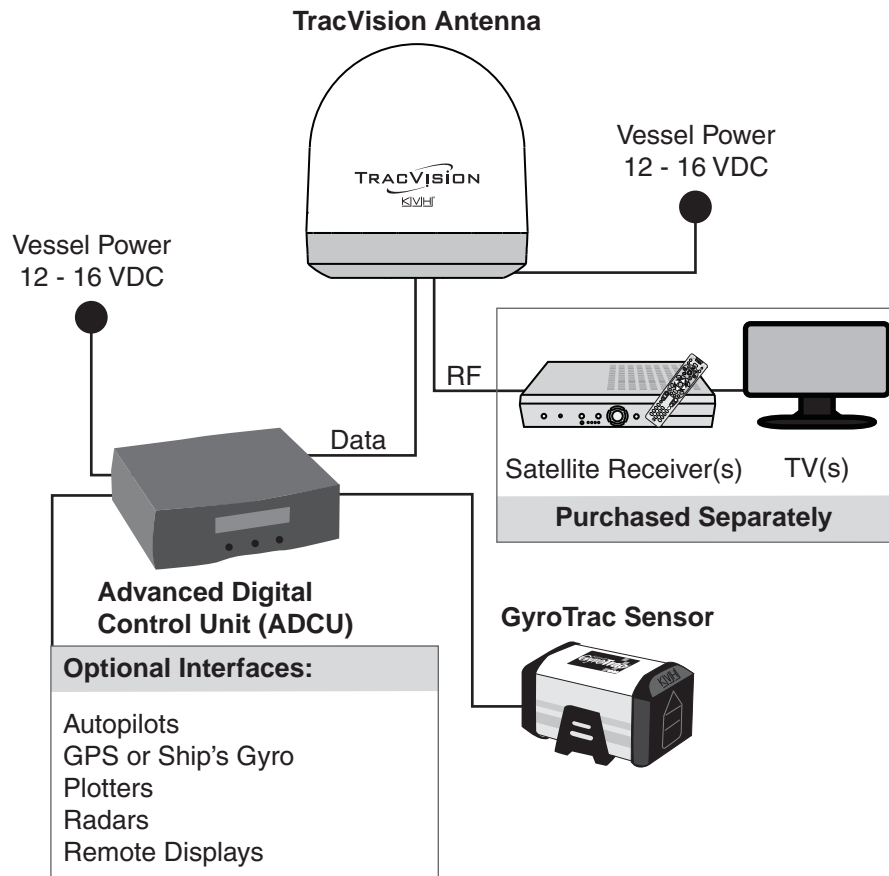

TIP: TracVision receiver wiring diagrams are provided in Appendix C on page 97. ADCU wiring diagrams are provided in Appendix D on page 103.

System Components

The TracVision M5/M7 includes the following components:

Antenna Unit

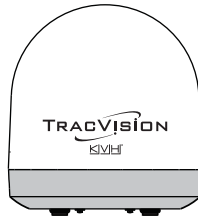

The antenna unit houses the antenna positioning mechanism, LNB (low noise block), and control elements within a radome. Weathertight connectors join the power, signal, and control cabling from the belowdecks units.

GyroTrac Sensor



The GyroTrac digital magnetic compass sensor provides a three-axis gyro-stabilized heading reference - allowing superior open water performance in any sea condition. It is also compliant with the IP67 standard; the unit is waterproof to a depth of 1 meter.

ADCU (Advanced Digital Control Unit)



The ADCU is the system's user interface, providing access to the system and its functions through an LCD with three buttons. The ADCU also serves as the system's junction box, allowing the system to interface with the GyroTrac sensor, and supply and receive data to/from the TracVision M5/M7 and other onboard equipment.

System Features

Your TracVision M5/M7 uses integrated DVB technology to quickly acquire and track the correct satellite, switch between your selected satellites, and send TV signals to the receiver.

In-motion Tracking

The TracVision system uses a state-of-the-art, actively stabilized antenna. Once the satellite is acquired, the antenna's internal gyros continuously measure the heading, pitch, and roll of your vessel and send commands to the antenna motors, keeping the antenna pointed at the satellite at all times - even while you're on the move!

Satellite Tracking and Switching

Your TracVision system tracks your selected satellites as long as the vessel is located within the selected satellites' coverage area. During installation, your TracVision system should have been set up to track your desired satellites, allowing you to switch between them quickly and easily.

Satellite Library

The TracVision M5/M7 includes a pre-programmed satellite library of the most popular satellite services, offering a wide variety of satellite services to choose from. For complete information on the satellite library, see "Settings" on page 31.

TIP: *You can add two more satellites of your choice to the satellite library. For complete information on adding satellites to the library, refer to the associated Application Note on the KVH Partner Portal (KVH-authorized technicians only).*

Navigational Data

Besides displaying satellite tracking information, the ADCU can also display navigational data, including magnetic heading, true heading, pitch, roll, yaw, rate of turn, and latitude and longitude position data.

NOTE: *Some displays require an active GPS connection. For more information on display types, see "ADCU Display Types" on page 26.*

Circular and Linear Versions

Your TracVision system is configured to receive either circularly polarized satellite signals (e.g., North America) or linearly polarized satellite signals (e.g., Europe or Latin America). Figure 1-3 illustrates the difference between these two polarizations.

Figure 1-3 Polarizations of Satellite Signals

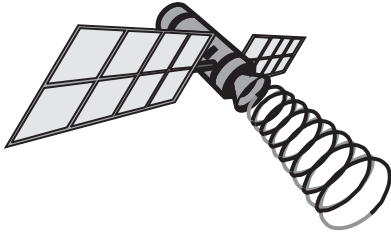
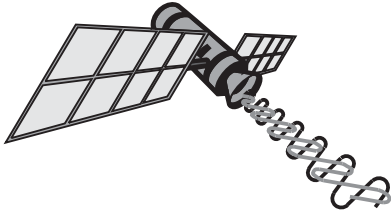
Circular	Linear
	
<p>Signals transmitted in two "corkscrew" patterns, one running clockwise and one running counter-clockwise</p>	<p>Signals transmitted in vertical and horizontal "waves" offset exactly 90° from each other</p>

LNB Skew Angle

Since linear satellite signals are oriented in a precise cross pattern, the TracVision antenna's receiving element, called an LNB (low-noise block), must be oriented in the same way to optimize reception. This orientation adjustment is referred to as the LNB's "skew angle." Figure 1-4 illustrates how skew determines the amount of a linear signal that the LNB collects. The more signal, the better the reception.

Figure 1-4 How Skew Works

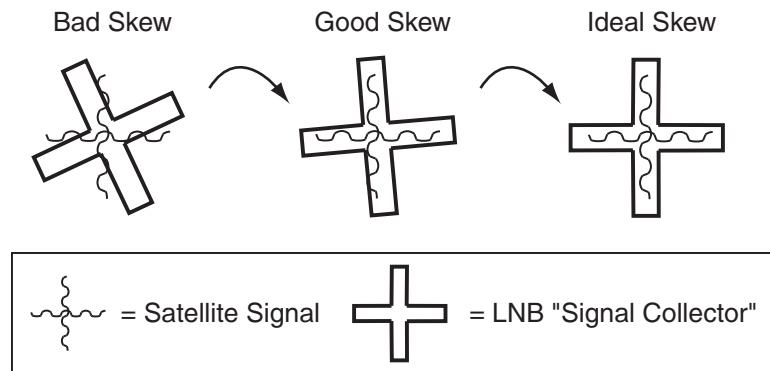

The correct skew setting varies depending on your geographic location, since the orientation of your antenna to the satellite changes as you move. For example, if your antenna is tracking the PAS 9 satellite for Sky Mexico programming, the ideal skew setting ranges from +30 to +70, depending upon your location within the satellite's coverage area (see Figure 1-5).

Figure 1-5 Approximate Skew Settings for the PAS 9 Satellite

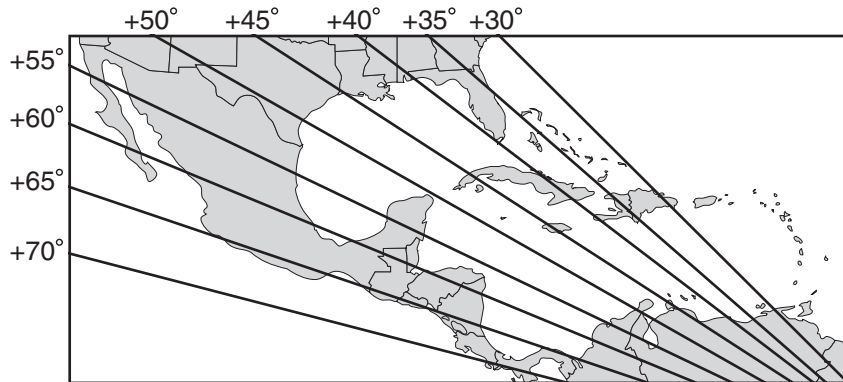

For complete details about adjusting the LNB's skew, see "Setting the LNB Skew Angle (Linear Versions Only)" on page 34.



2. Operation

This chapter explains everything you need to know to operate the TracVision system.

Contents

Receiving Satellite TV Signals	13
Turning the System On/Off	14
Changing Channels and Switching Between Satellites (Circular Versions)	15
Changing Channels and Switching Between Satellites (Linear Versions).....	21
Receiver Requirements	24
ADCU Display Types.....	26
Product Care.....	29



Receiving Satellite TV Signals

Television satellites are located in fixed positions above the Earth's equator and beam TV signals down to certain regions of the planet (not worldwide). To receive TV signals from a satellite, you must be located within that satellite's unique coverage area.

TIP: For your convenience, KVH provides links to several websites that offer satellite coverage information. Simply visit our website at www.kvh.com/footprint.

Figure 2-1 Location and Coverage Area of DIRECTV 101 Satellite

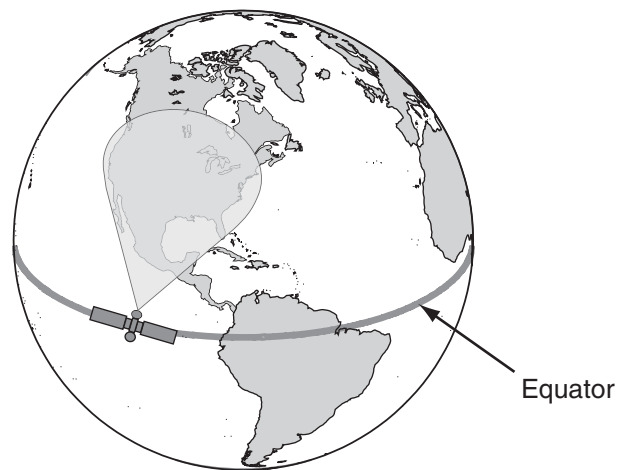

In addition, since TV satellites are located above the equator, the TracVision antenna must have a clear view of the sky to receive satellite TV signals. Anything that stands between the antenna and the satellite can block the signal, resulting in lost reception. Common causes of blockage include boat masts, trees, buildings, and bridges. Heavy rain, ice, or snow might also temporarily interrupt satellite signals.

Figure 2-2 Example of Satellite Blockage

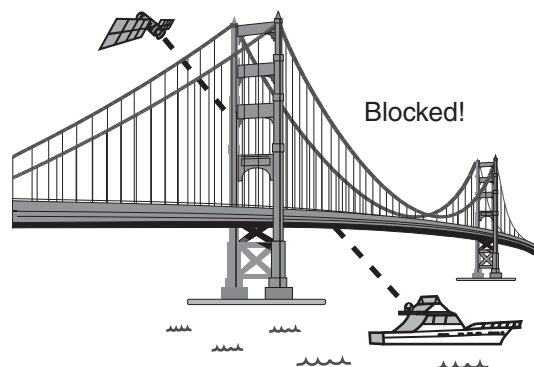

Turning the System On/Off

Since power to the TracVision system is controlled by the vessel power, you can turn the system on or off by applying/removing vessel power.

Turning On the System

Follow the steps below to turn on your TracVision system.

IMPORTANT!

Avoid turning the vessel or changing channels for one minute after turning on the system.

1. Make sure the antenna has a clear view of the sky.
2. Turn on your satellite TV receiver and TV.
3. If a GPS is connected, ensure the GPS receiver has obtained an accurate position.
4. Apply operating power to the TracVision system.

TIP: When operating power is applied to the ADCU, the ADCU initiates a startup sequence. The LCD updates as diagnostic tests are performed.

5. Wait one minute for system startup. The ADCU will display the Tracking Satellite screen after system self testing is complete.

Figure 2-3 Tracking Satellite Screen

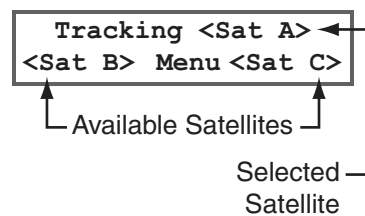

Turning Off the System

Follow the steps below to turn off your TracVision system.

1. Remove operating power from the TracVision system.
2. Turn off your satellite TV receiver and TV.

Changing Channels and Switching Between Satellites (Circular Versions)

During installation, your TracVision system should have been set up to track the satellite(s) of your choice and the channel guides for your selected satellite service should have been downloaded.

Since some channels might be located on another satellite, changing channels might require switching between satellites. With most TracVision configurations, satellite switching occurs automatically while you change channels using the primary receiver's remote control. Find your selected service and configuration in the following sections for complete details.

TIP: *The primary receiver is the receiver connected to the antenna's RF1 connector.*

DISH 1000 (Required for TurboHD Service)

When the TracVision M5/M7 system is configured for DISH 1000, you can view the DISH HDTV programming for your geographic area. You can configure the system for either DISH 1000/61 or DISH 1000/129 use.

Figure 2-4 DISH 1000 Configurations

Configuration	Satellites Tracked
DISH 1000/61	DISH 110, 119, and 61
DISH 1000/129	DISH 110, 119, and 129

During installation, your TracVision system should have been set to the DISH 1000 configuration that best suits your geographic location (see Figure 2-5) and local channels requirements. If you change satellite coverage areas, refer to "DISH 1000 Setup" on page 42 to change your DISH 1000 configuration.

Figure 2-5 Regional DISH 1000 Configuration Recommendations

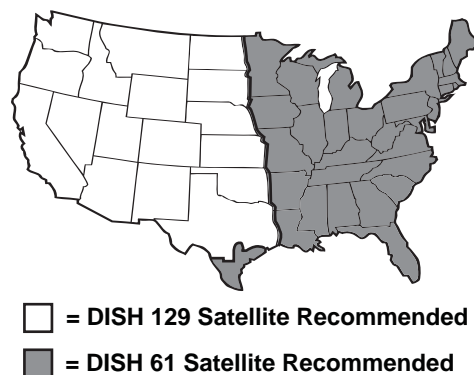

DISH 1000 Automatic Mode - Preferred for One or Two Receivers

The antenna switches between satellites automatically as you change channels using the primary receiver's remote control. The primary receiver is the receiver connected to the antenna's RF1 cable (see Figure 2-6 and Figure 2-7). If an optional secondary receiver is connected, you can use its remote control to switch between the channels on the currently selected satellite.

Figure 2-6 DISH 1000 Automatic Mode - Receiver Controls

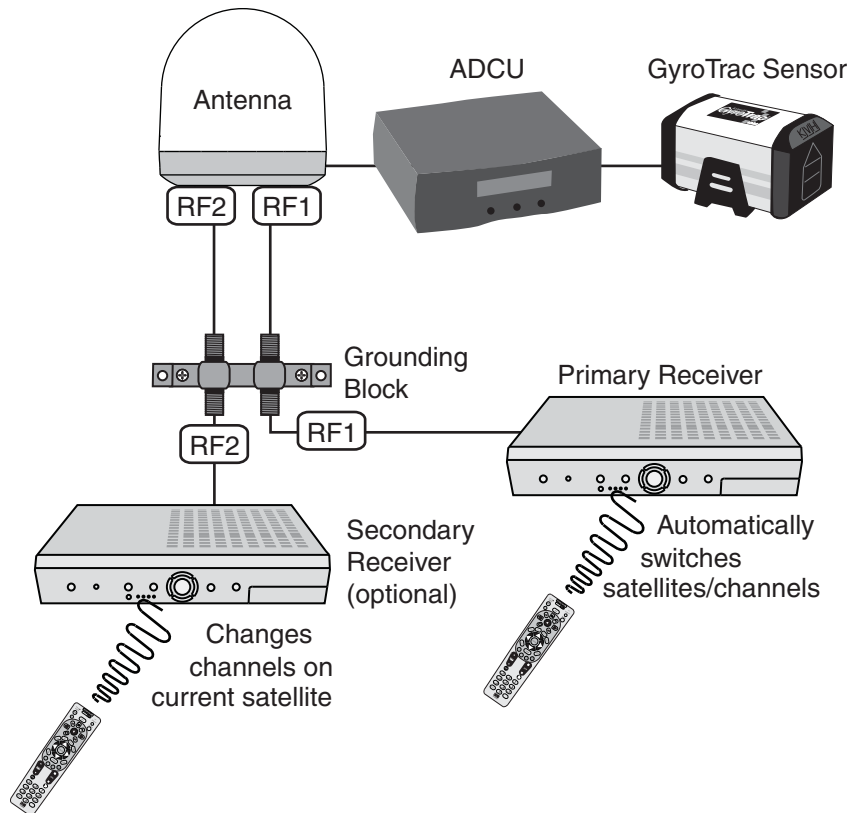
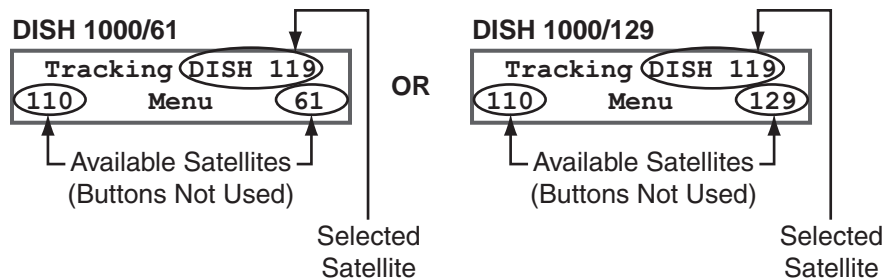

Figure 2-7 DISH 1000 Automatic Mode - ADCU Displays



DISH 1000 Manual Mode - Required for Three or More Receivers

Since multiswitches interfere with communications between the receivers and the antenna, the system must be set up in Manual mode when three or more receivers are installed. When Manual mode is enabled, you can switch between your selected satellites using the buttons on the front of the ADCU (see Figure 2-8 and Figure 2-9). You can use the receivers' remote controls to switch between the channels on the currently selected satellite.

Figure 2-8 DISH 1000 Manual Mode - Receiver/ADCU Controls

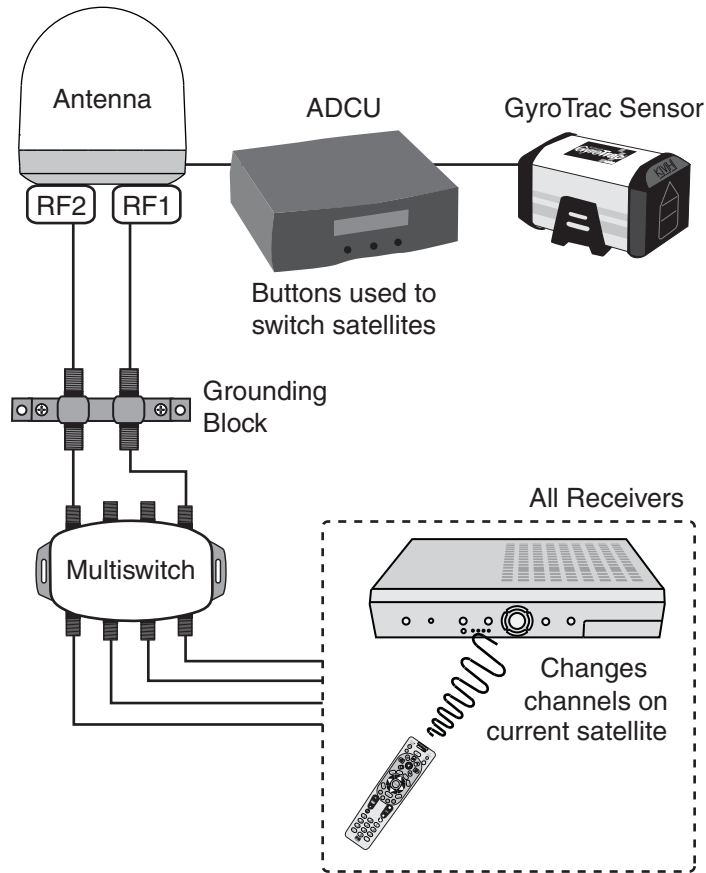
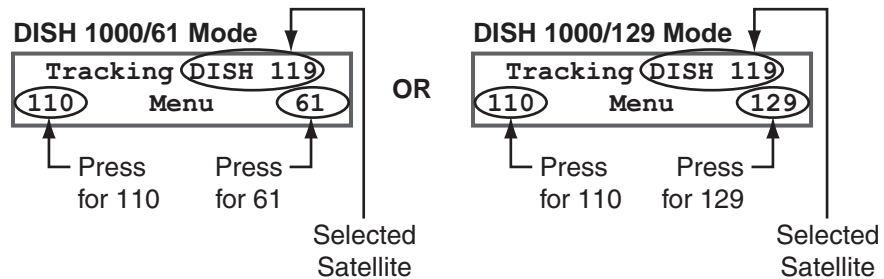

Figure 2-9 DISH 1000 Manual Mode - ADCU Displays



Dual-Sat Mode - DISH 500, ExpressVu, DIRECTV, and Custom Dual-Sat Setups

Dual-Sat Mode is used with several service configurations. Figure 2-10 lists each Dual-Sat service configuration, the satellites tracked for each service, and the available satellite switching modes.

Figure 2-10 Dual-Sat Modes

Service	Satellites Tracked	Available Switching Mode(s)
DIRECTV	DIRECTV 101 and 119	Auto or Manual
DISH 500	DISH 119 and 110	Auto or Manual
ExpressVu	ExpressVu 91 and 82	Auto or Manual
Custom	Selected by user	Manual

Dual-Sat Automatic Mode - Preferred Mode for One or Two Receivers*

The antenna switches between satellites automatically while you change channels using the primary receiver's remote control. The primary receiver is the receiver connected to the antenna's RF1 cable (see Figure 2-11 and Figure 2-12). If an optional secondary receiver is connected, you can use its remote control to switch between the channels on the currently selected satellite.

***NOTE:** Custom Dual-Sat configurations must use Manual mode.

Figure 2-11 Dual-Sat Automatic Mode - Receiver Controls

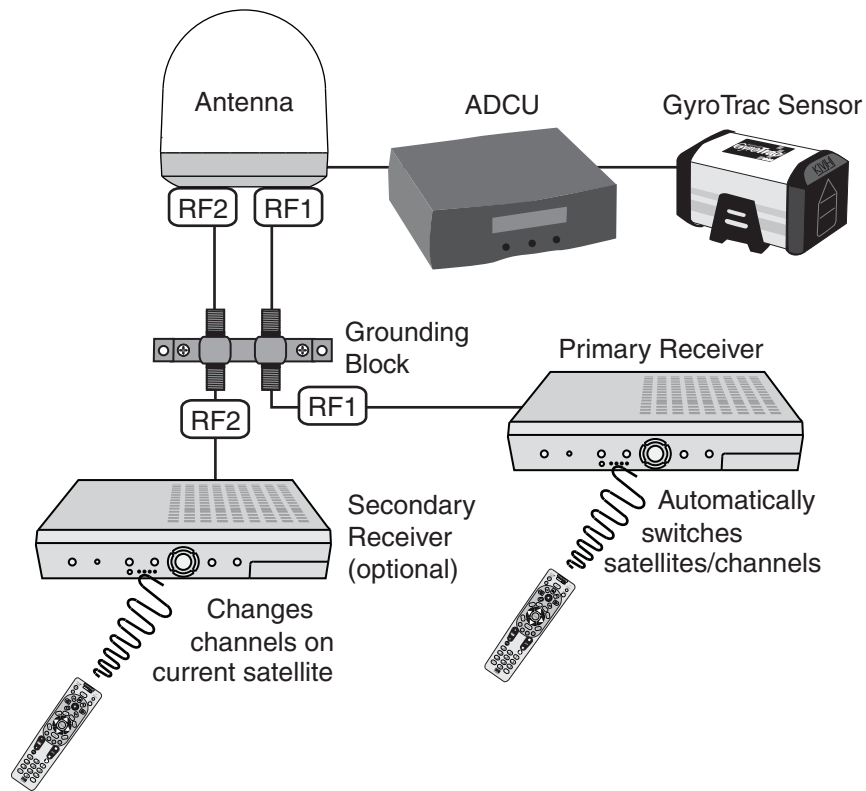
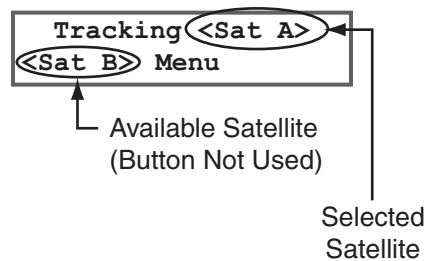

Figure 2-12 Dual-Sat Automatic Mode - ADCU Display



Dual-Sat Manual Mode - Required for Three or More Receivers and All Custom Dual-Sat Setups

Circular TracVision M5/M7 systems with three or more receivers require the use of a multiswitch. Since multiswitches interfere with communications between the receivers and the antenna, the system must be set up in Manual mode. When manual mode is enabled, you can use the receiver's remote control to change channels on the currently selected satellite. If you need to switch satellites, simply use the buttons on the front of the ADCU (see Figure 2-13 and Figure 2-14). You can use the receivers' remote controls to switch between the channels on the currently selected satellite.

Figure 2-13 Dual-Sat Manual Mode - Receiver/ADCU Controls

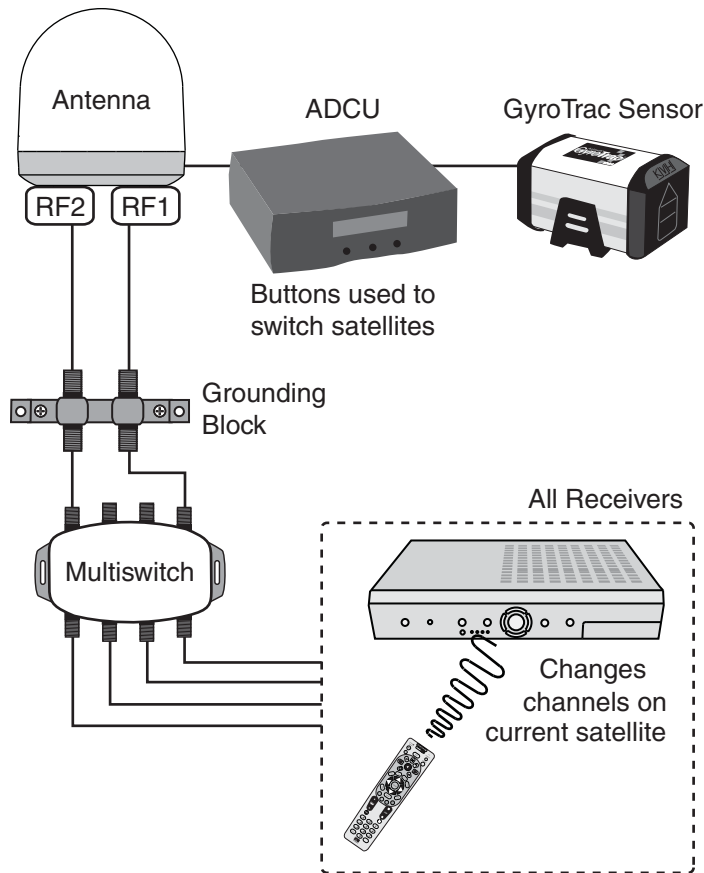
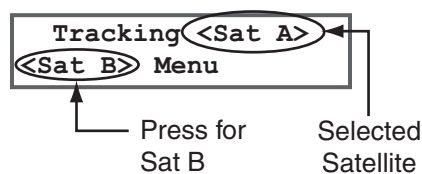

Figure 2-14 Dual-Sat Manual Mode - ADCU Display





Changing Channels and Switching Between Satellites (Linear Versions)

During installation, your TracVision system should have been set up to track the satellite(s) of your choice and the channel guides for your selected satellite service should have been downloaded.

Since some channels might be located on another satellite, changing channels might require switching between satellites. Switching satellites occurs automatically with most TracVision system configurations. However, if the TracVision system includes a multiswitch, manual satellite switching is required.

NOTE: *To enable automatic switching, the receiver must be properly configured (see “Linear Receiver Configuration” on page 25 for more information).*

Automatic Satellite Switching

The TracVision system can switch between satellites automatically as long as the primary receiver is set up for DiSEqC communications and a multiswitch is not installed. With DiSEqC set up, the primary receiver sends satellite switching commands to the antenna as necessary when you change channels using the primary receiver's remote control. The primary receiver is the receiver connected to the antenna's RF1 cable (see Figure 2-15). If an optional secondary receiver is connected, you can use its remote control to switch between the channels on the currently selected satellite.

Figure 2-15 Primary/Secondary Receiver Control (Dual-output version shown)

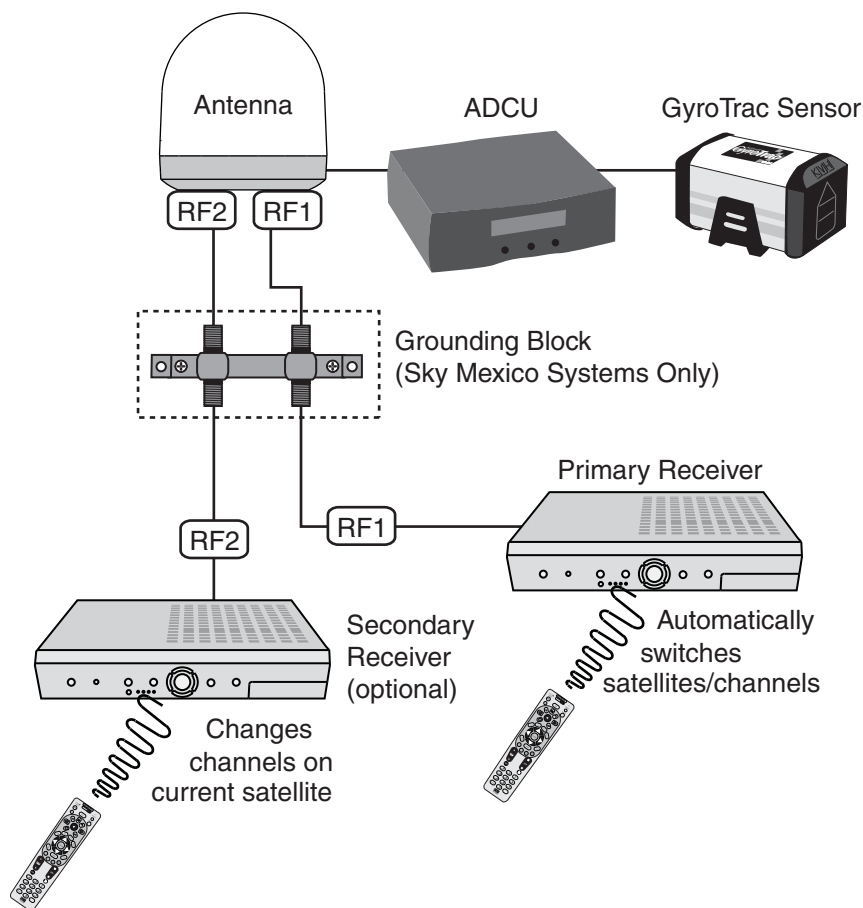
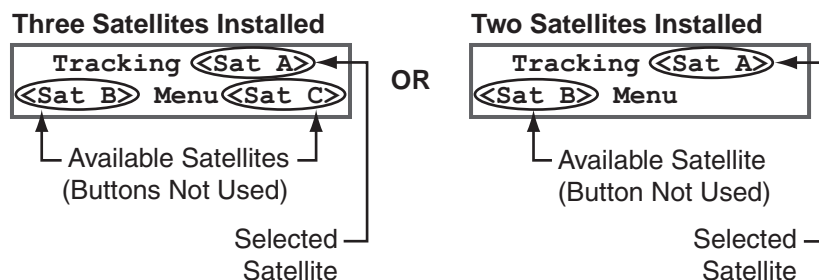

Figure 2-16 Automatically Switching Between Satellites - ADCU Display



Manual Satellite Switching

If the TracVision system includes a multiswitch, you can use the receivers' remote controls to change channels on the currently selected satellite. If you need to switch satellites, simply use the buttons on the front of the ADCU (see Figure 2-17 and Figure 2-18).

IMPORTANT!

Pressing a button on the ADCU to manually switch satellites disables DiSEqC monitoring for automatic switching. The antenna must be turned off, then back on, to restore DiSEqC communications.

Figure 2-17 Manual Satellite Switching - Receiver/ADCU Controls (Quad-output LNB Version Shown)

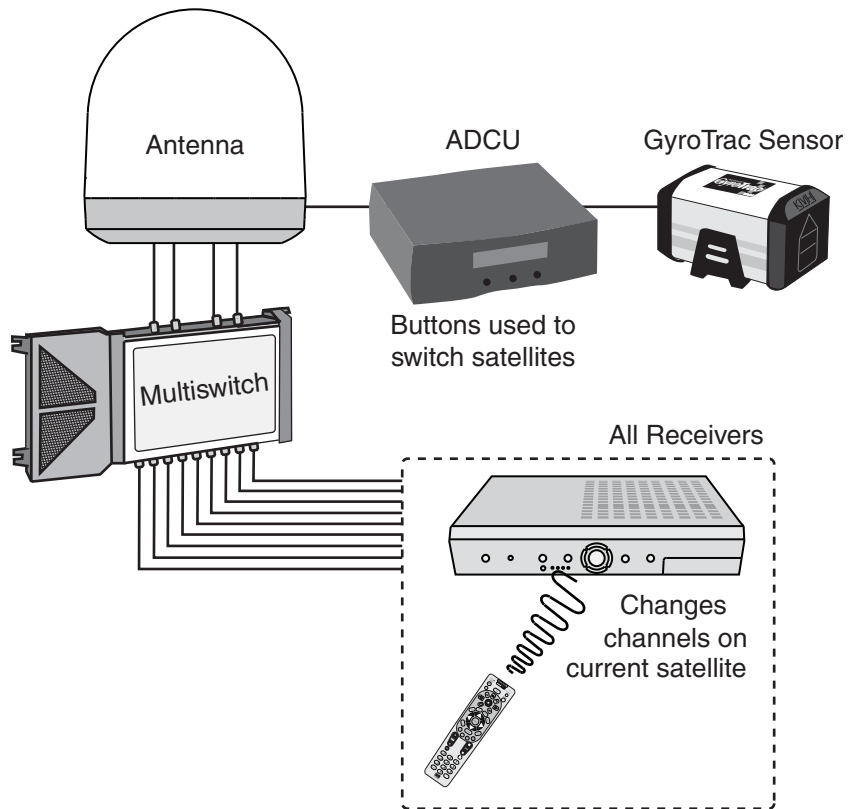
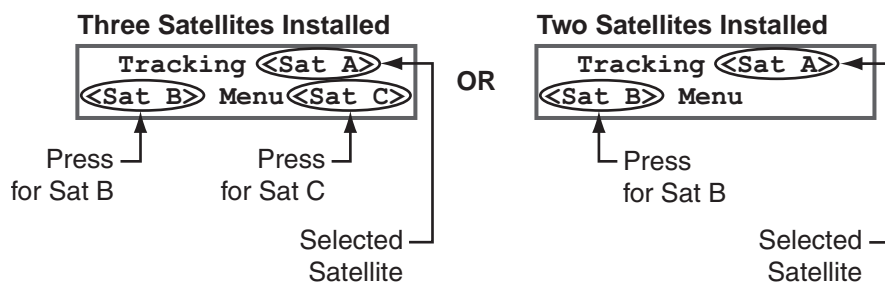

Figure 2-18 Manually Switching Between Satellites - ADCU Displays



Receiver Requirements

This section lists U.S. and Canadian circular receiver models that are compatible with the TracVision M5/M7 system and explains linear and circular receiver setup requirements.

Circular Receiver Compatibility

To ensure compatibility with your TracVision M5/M7 system, be sure to use a KVH-validated receiver for your selected service type (see Figure 2-19).

Figure 2-19 KVH-Validated U.S. and Canadian Receivers

Standard-definition receivers		
DIRECTV	DISH	ExpressVu
D12	311	4100
D11		3100
D10		
High-definition receivers		
DIRECTV	DISH	ExpressVu
HD not supported	211k 211	6100

NOTE: For information on connecting different receiver models, contact KVH Technical Support at 1-401-847-3327.

DISH Network/ExpressVu Receiver Configuration

If your TracVision M5/M7 system is set up for DISH Network or ExpressVu service, your receiver(s) should have also been configured during installation. In most cases, you do not need to reconfigure your receiver(s). However, Figure 2-20 lists special scenarios that require DISH Network/ExpressVu receiver configuration.

Figure 2-20 Receiver Configuration Requirements

Receiver Configuration is Required When...
<ul style="list-style-type: none"> • DISH 1000 only - You change satellite coverage areas (see Figure 2-5 on page 15) • You add a receiver • You have reconfigured a receiver for home use

If you need to configure a receiver(s) for DISH Network/ExpressVu service, follow the instructions for your selected service type in Chapter 3, "Settings" on page 31.

Linear Receiver Configuration

If the TracVision system does not include a multiswitch, you can configure the receiver(s) to enable automatic satellite switching. TracVision systems with a multiswitch installed require switching satellites manually using the ADCU, which does not require receiver configuration.

To configure the receivers for automatic switching, set up the satellites in the receiver in the same order they were set up in the TracVision system (see Figure 2-21).

Figure 2-21 Antenna/Receiver Synchronization Settings

TracVision Satellite	Receiver Satellite	DiSEqC Setting
Satellite A	Alternative 1 or A	DiSEqC 1
Satellite B	Alternative 2 or B	DiSEqC 2
Satellite C*	Alternative 3 or C	DiSEqC 3

**NOTE: Only European Tri-Sat configurations track three satellites.*

ADCU Display Types

The ADCU has several display types. The default antenna display type displays satellite tracking information. The ADCU can also display navigational data when one of the following display types is selected: compass; pitch; roll and yaw; rate of turn; and latitude/longitude.

Display Type Data

This section describes each display type and the data displayed. If you wish to change the display type, refer to “Changing Display Types” on page 28.

Antenna

The antenna display type is the TracVision M5/M7 system’s default display type. When the ADCU is set to the antenna display type, satellite tracking information is displayed.

Figure 2-22 Tracking Satellite Screen

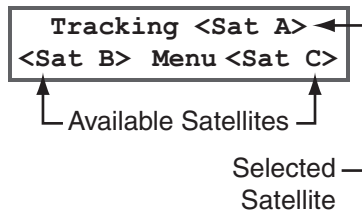

Compass

The compass display type displays the vessel’s heading information. If GPS is not connected or if GPS is connected but was not properly initialized prior to turning on the TracVision system, the Compass screen displays the magnetic heading value (see “Turning the System On/Off” on page 14 for details on GPS initialization).

Figure 2-23 Compass Screen with Magnetic Heading

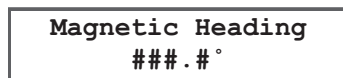

When GPS is connected and is properly initialized, the Compass screen displays both magnetic heading and true heading values.

Figure 2-24 Compass Screen with Magnetic and True Heading

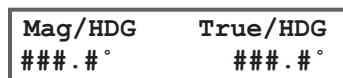

Pitch, Roll, and Yaw

The pitch, roll, and yaw display type displays the vessel's pitch, roll, and yaw values.

Figure 2-25 Pitch, Roll, and Yaw Screen

Pitch	Roll	Yaw
#.#°	#.#°	#.#°

Rate of Turn

The rate of turn display type displays the vessel's magnetic heading and rate of turn values.

Figure 2-26 Rate of Turn Screen

Mag/HDG	Rate/sec
###.#°	###.#°

Latitude/Longitude

When GPS is connected and is properly initialized, the Latitude/Longitude screen displays the vessel's latitude and longitude values (see "Turning the System On/Off" on page 14 for details on GPS initialization).

Figure 2-27 Latitude/Longitude Screen

Latitude:	##N
Longitude:	###E

Changing Display Types

Use the flowchart in Figure 2-28 if you wish to change the display type.

Figure 2-28 Changing Display Types

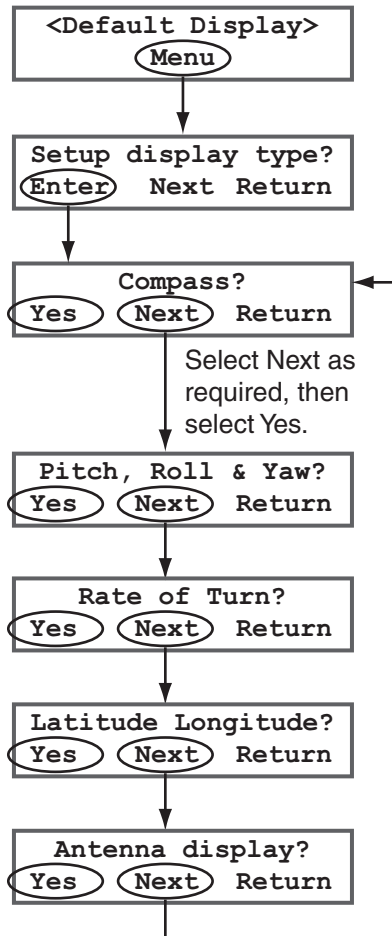



Product Care

Please consider the following antenna care guidelines for maintaining peak performance:

- Periodically wash the exterior of the antenna dome with fresh water and mild detergent. Avoid harsh cleansers and volatile solvents (such as acetone) and do not spray the dome directly with high-pressure water.
- If you wish to paint the dome, use only non-metallic automotive paint without a primer coat. Any paint that contains metal will block satellite signals and impair reception.



3. Settings

This chapter contains information on system settings and how to modify them using the ADCU.

Contents

Manually Setting Latitude and Longitude	33
Setting the LNB Skew Angle (Linear Versions Only)	34
Connecting a PC	40
DISH 1000 Setup	42
Dual-Sat or Single Satellite Setups	46
European Tri-Sat Mode Setup	52
Setting Instant On Mode	55
Setting Sleep Mode	56
Adjusting Display Brightness	57
Restarting the TracVision System	58



Manually Setting Latitude and Longitude

When a GPS receiver is detected, the TracVision system does not require manually set latitude and longitude values. However, if an active GPS is not connected, you can use the flowchart in Figure 3-1 to manually set the latitude and longitude values in the antenna, which will speed up satellite acquisition.

TIP: For your convenience, you can determine your approximate latitude and longitude using the Position Grids provided in Appendix E on page 107.

Figure 3-1 Setting Latitude and Longitude Manually

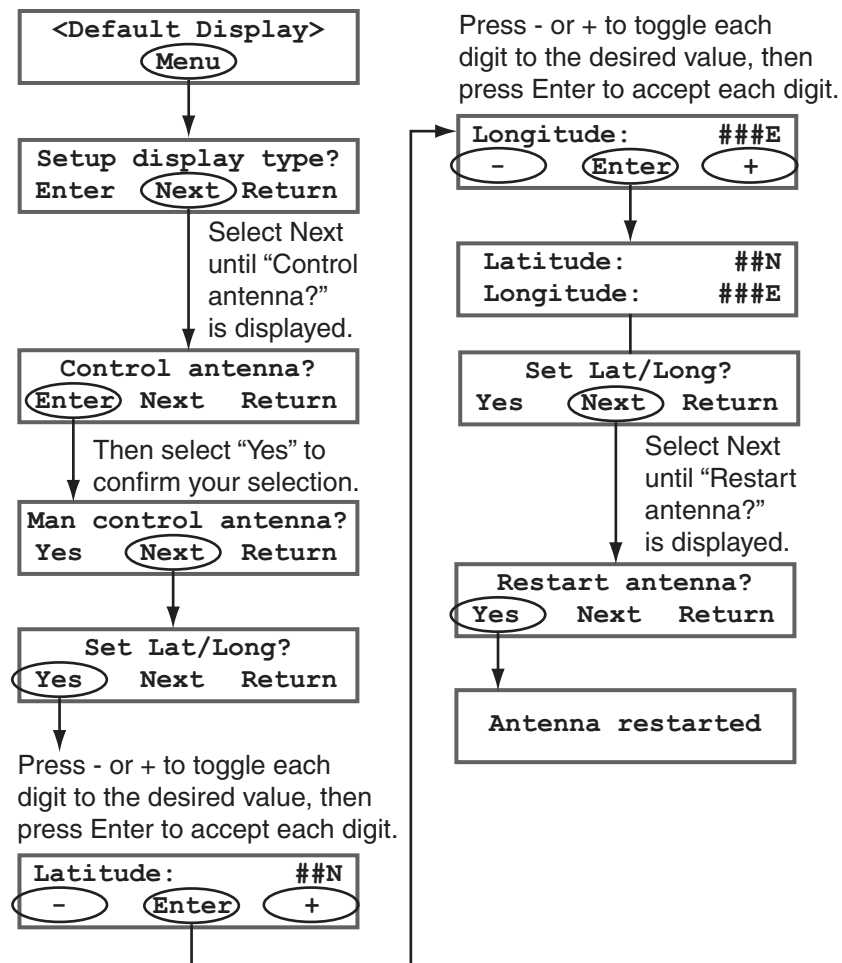

Setting the LNB Skew Angle (Linear Versions Only)

To optimize satellite signal reception, you need to adjust the skew angle on the LNB whenever you change your geographic location or change which satellites are set up for tracking.

IMPORTANT!

If an active GPS is not connected, be sure to enter your latitude and longitude manually before performing this procedure (see “Manually Setting Latitude and Longitude” on page 33).

TIP: For information on how skew works, see “Circular and Linear Versions” on page 9.

Determining the Skew Angle

Use the flowchart in Figure 3-2 to determine the skew angle of the currently selected satellite using the ADCU.

NOTE: If you wish to determine the average skew for two or three satellites, determine the skew angle for each satellite by performing the procedure below, then divide by the number of installed satellites.

TIP: Sky Mexico subscribers can also refer to Figure 1-5 on page 10 for approximate skew settings for the PAS-9 satellite.

Figure 3-2 Determining the Skew Angle Using the ADCU

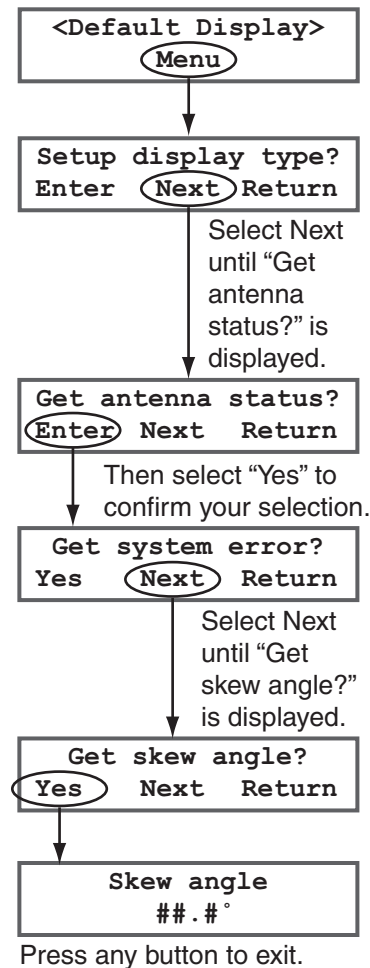

Adjusting the Skew Angle

Once you have determined the proper skew angle, follow the steps below to adjust the antenna's LNB skew angle.



CAUTION

To avoid bodily injury, be sure to turn off the antenna and disconnect power to all wired components.

1. Using a Phillips-head screwdriver, remove the screws securing the radome. Then remove the radome and set it aside in a safe place.
2. Locate the LNB assembly on the back of the antenna reflector (see Figure 3-3).

Figure 3-3 Location of LNB on Back of Antenna Reflector

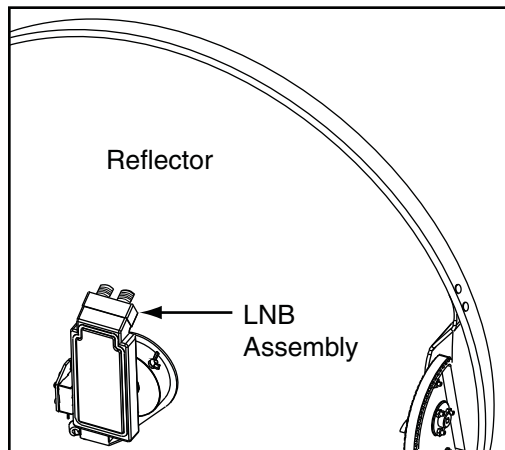

- Using a 2 mm allen hex key, loosen the two M4 socket set screws securing the LNB. The location of the screws varies according to TracVision model; refer to Figure 3-4 or Figure 3-5.

Figure 3-4 TracVision M5 Set Screws

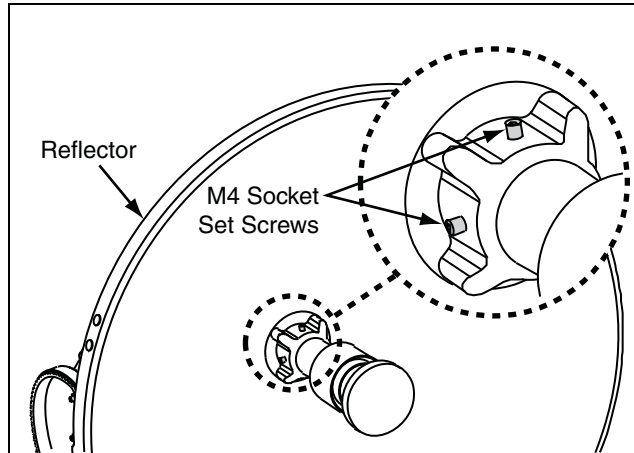
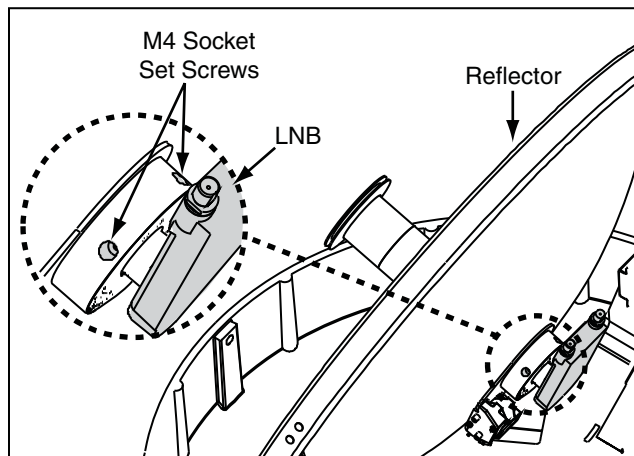

Figure 3-5 TracVision M7 Set Screws



- 4a. TracVision M5 Only** - Adjust the LNB clockwise or counter-clockwise, until the skew arrow on the LNB points to the skew angle that you determined earlier. Due to physical constraints, if the skew angle is greater than $+15^\circ$, you need to subtract 180 to get the equivalent negative skew angle and set the LNB to that angle instead. For example, if the skew angle is determined to be $+30^\circ$, set the skew to -150° .

IMPORTANT!

Be sure to keep the LNB fully inserted in the choke feed to ensure optimum performance.

Figure 3-6 TracVision M5 LNB Skew Angle Adjustment

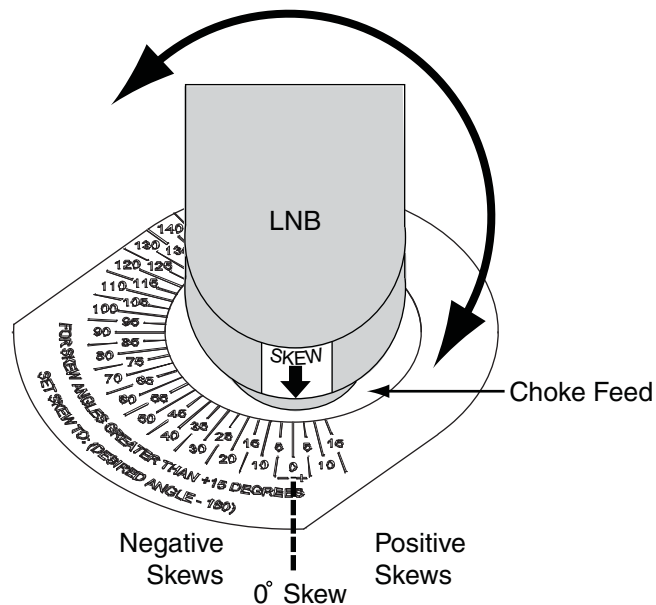

4b. TracVision M7 Only - Adjust the LNB clockwise or counter-clockwise, until the skew arrow on the LNB points to the skew angle that you determined earlier.

IMPORTANT!

Be sure to keep the LNB fully inserted in the choke feed to ensure optimum performance.

Figure 3-7 TracVision M7 LNB Skew Angle Adjustment

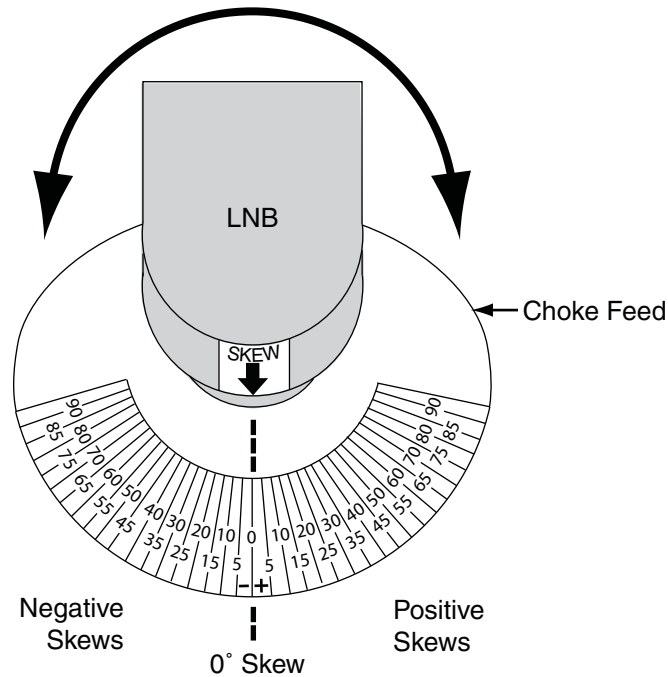

5. Tighten the two M4 socket set screws to secure the LNB in place. Apply 9 in-lbs (1 Nm) of torque, if possible.
6. Reinstall the radome.
7. Restore power to the TracVision system.

Connecting a PC

Follow the instructions below if you need to connect a PC to the TracVision M5/M7 system. This procedure requires a PC with Windows HyperTerminal (or equivalent) and a serial data cable.

TIP: *If you are a KVH-authorized technician, you can use the KVH Flash Update Wizard instead of HyperTerminal. Enter commands in the Wizard's "TracVision Antenna Comms" window. You do not need to flash the antenna to enter commands.*

1. Connect a serial data cable from the maintenance port (DB9 connector) located on the back of the ADCU to the serial port on your PC.

Figure 3-8 Connecting a PC to the ADCU

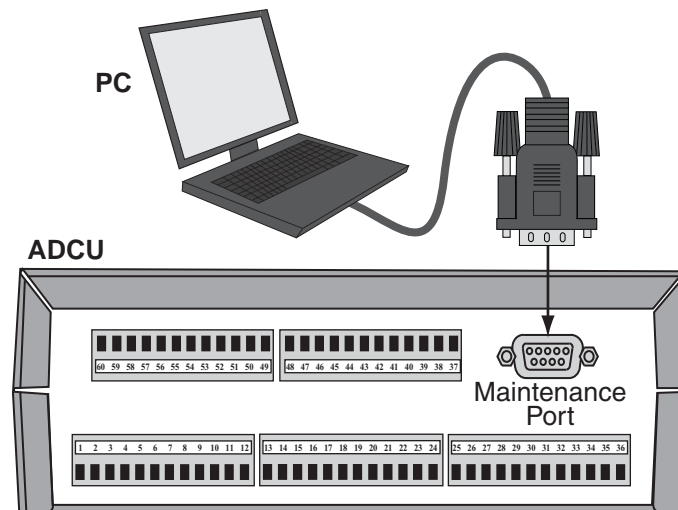

TIP: *If your computer does not have a DB9 serial COM port, you can use the following USB-to-RS232 adapters: IO Gear Part # GUC232A (visit www.iogear.com), Belkin Part # F5U109, or Belkin Part # F5U409 (visit www.belkin.com).*

2. Open HyperTerminal and establish the following settings:

- Bits per second: 9600
- Data bits: 8
- Parity: None
- Stop Bits: 1
- Flow Control: None

Figure 3-9 HyperTerminal Settings



TIP: To view characters on the screen as you type, set up HyperTerminal to echo typed characters. Select "Properties" from the File menu; select "ASCII Setup" at the Settings tab; then select "Echo typed characters locally" at the ASCII Setup window.

DISH 1000 Setup

This section explains how to configure the TracVision system for DISH Network's three-satellite service (e.g., TurboHD). For operation instructions and additional information on DISH modes, refer to "Changing Channels and Switching Between Satellites (Circular Versions)" on page 15.

Step 1 - Configure the System

1. Stop the vessel in a blockage-free area.
2. Connect a PC to the TracVision system as described in "Connecting a PC" on page 40. You will enter the following PC commands into the HyperTerminal window. (An example is provided in Figure 3-10.)
3. Apply operating power to the TracVision system. Turn on the TV(s) and receiver(s).
4. Type **HALT** then press Enter.
5. Type the appropriate **SATINSTALL** command from the table below, then press Enter.

To Configure:	Type:
DISH 1000/61	SATINSTALL,TRISAT,DISH61
DISH 1000/129	SATINSTALL,TRISAT,DISH

***TIP:** Be sure to select the appropriate DISH 1000 configuration for your geographic area. Refer to "DISH 1000 (Required for TurboHD Service)" on page 15 for more information.*

6. Type **ZAP** then press Enter to restart the antenna. Wait one minute for system startup.

Figure 3-10 Example, Configuring DISH 1000/61

```
HALT
SATINSTALL,TRISAT,DISH61
ZAP
```

Step 2 - Update Latitude and Longitude Data (if necessary)

If you do not have a GPS connected to the ADCU, you need to enter your vessel's latitude and longitude into the system.

Use the flowchart in Figure 3-11 to manually set the latitude and longitude values. When the TracVision system uses current latitude and longitude data, satellite acquisition time is minimized.

TIP: For your convenience, you can determine your approximate latitude and longitude using the Position Grids provided in Appendix E on page 107.

Figure 3-11 Setting Latitude and Longitude Manually

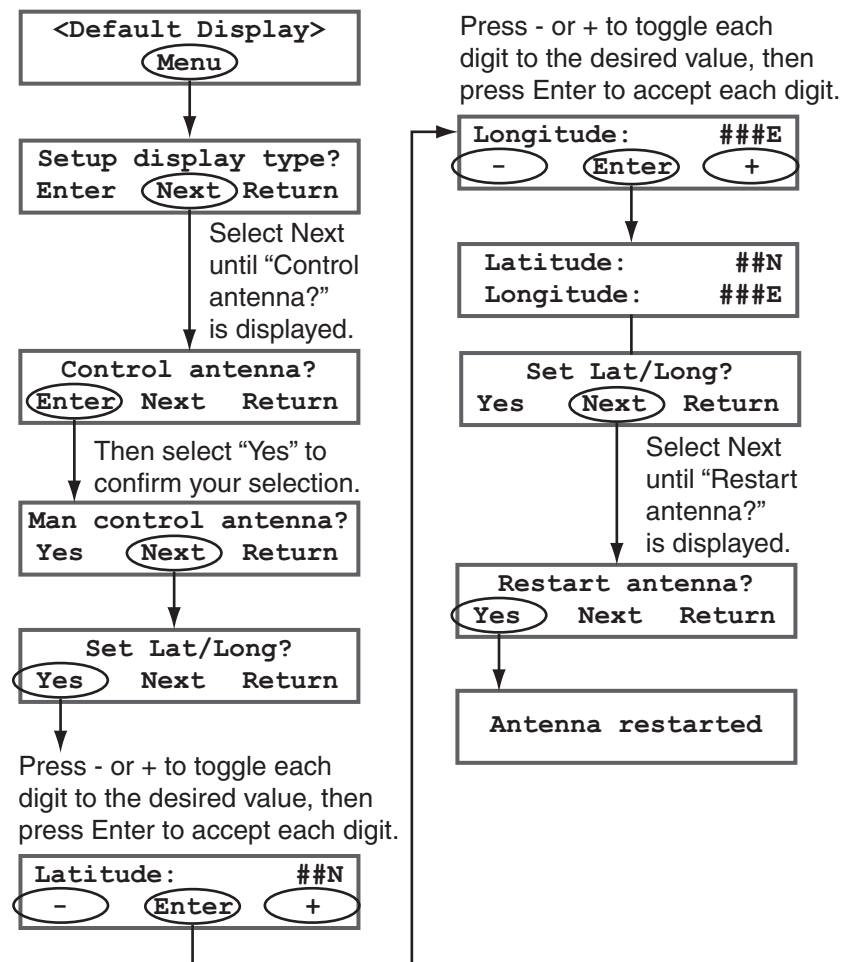

Step 3 - Configure the Receiver(s)

NOTE: *If you are connecting multiple receivers, repeat this process for each additional receiver. You will need to connect each receiver, one at a time, to the RF1 cable and perform the steps below. Then, once you have completed this process for each receiver, you can reconnect them as desired.*

IMPORTANT!

This procedure must be performed while the vessel is stopped in calm waters.

1. Ensure the receiver you wish to configure is connected to the TracVision system's RF1 cable.
2. Turn on the TV and receiver.
3. Apply power to the TracVision system. Wait until the tracking screen for your selected DISH 1000 configuration is displayed.

Figure 3-12 Tracking Screens

DISH 1000/61 Mode	Tracking DISH 119 110 Menu 61
DISH 1000/129 Mode	Tracking DISH 119 110 Menu 129

4. Using the receiver's remote, go to the "Point Dish/Signal Strength" screen (press MENU, 6, 1, 1 on most models).
5. Choose **Check Switch**, then press SELECT.
6. Choose **Test**, then press SELECT.
7. Wait at least 15 minutes before proceeding. Disregard messages on the TV stating the test is complete; you must wait 15 minutes before proceeding.

IMPORTANT!

Please be patient. The Check Switch test takes approximately 15 minutes to complete. Disregard any messages on the TV stating the test is complete; the antenna must perform additional operations before proceeding.

8. After waiting 15 minutes, repeat Steps 4-6 to run a second Check Switch test.
9. Verify the values on your TV match those required for your selected DISH 1000 configuration (see Figure 3-13 and Figure 3-14). If your values do not match, turn off the antenna, then turn it back on and repeat Steps 4-8.

Figure 3-13 DISH 1000/61 Second Check Switch Results on TV Screen

Port	1	2	3
Satellite	119	110	61
Trans	OK	OK	OK
Status	Reception Verified		
Switch	SW64		

Figure 3-14 DISH 1000/129 Second Check Switch Results on TV Screen

Port	1	2	3
Satellite	119	110	129
Trans	OK	OK	OK
Status	Reception Verified		
Switch	SW64		

10. Exit the menu and allow the receiver to download the program guide.

NOTE: *You do not need to perform this procedure again unless you add another receiver, you reconfigure a receiver(s) for home use, or you move to a different DISH 1000 satellite coverage area (see "DISH 1000 (Required for TurboHD Service)" on page 15).*

Dual-Sat or Single Satellite Setups

The following instructions explain how to configure the TracVision system to track one or two satellites of your choice from the antenna's satellite library. For operation instructions, refer to "Operation" on page 11.

IMPORTANT!

Be sure to stop the vessel in a blockage-free area before performing this procedure. Excessive motion or satellite blockage can prevent proper configuration.

NOTE: Be sure to only install satellites that your TracVision M5/M7 system can track in your geographic location. For your convenience, KVH provides links to several websites that offer satellite coverage information. Simply visit our website at www.kvh.com/footprint.

Step 1 - Select Satellites

You can select up to two satellites from either the circular satellite library (see Figure 3-15) or the linear satellite library (see Figure 3-16 on page 48).

Figure 3-15 Circular Satellite Library

Satellite Service	Satellite Location	Installation Name
AsiaSat 4	122.2° E	ASIASAT*
DIRECTV	72.0° W	DSS_72
	101.0° W	DSS_101
	110.0° W	DSS_110*
	119.0° W	DSS_119
DIRECTV Latin America	95.0° W	GALAXY3CN*
DISH Network	61.5° W	ECHO_61
	110.0° W	ECHO_110
	119.0° W	ECHO_119
	129.0° W	ECHO_129
ExpressVu	91.0° W	EXPRESSTV
	82.0° W	EXPRESSVU

***NOTE:** Reception of these satellites requires special hardware. Please contact your local KVH-authorized dealer or KVH Technical Support for details.

NOTE: If you wish to track only one of the satellites listed above, type "NONE" to substitute the second satellite. For example, ExpressVu subscribers who wish to track just the 91 satellite should type "SATINSTALL,EXPRESSTV,NONE".

Figure 3-16 Linear Satellite Library

Satellite Location	Satellite	Installation Name
26.0° E	Arabsat	ARABSAT
19.2° E	Astra 1	ASTRA1
28.2° E	Astra 2N	ASTRA2N
28.2° E	Astra 2S	ASTRA2S
7.0° E	Eutelsat W3A	EUTEL_W3A
30.0° W	Hispasat	HISPASAT
13.0° E	Hotbird	HOTBIRD
13.0° E	Hotbird WB	HOTBIRDWB
7.0° W	Nilesat	NILESAT
160.0° E	Optus D1	OPTUS_D1
156.0° E	Optus C1	OPTUS_C1
58.0°W	Pas 9	PAS_9
110.5° E	Sinosat 1	SINOSAT*
5.0° E	Sirius	SIRIUS
0.8° W	Thor	THOR
42.0° E	Turksat 1C	TURKSAT1C

***NOTE:** Reception of this satellite requires special hardware. Please contact your local KVH-authorized dealer/distributor or KVH Technical Support for details.

NOTE: If you wish to only track one of the satellites listed above, type "NONE" to substitute the second satellite. For example, to install only the Astra 1 satellite, type "SATINSTALL,ASTRA1,NONE".

Step 2 - Configure the TracVision System

Now you need to configure the TracVision system to track your selected satellites. Use the flowchart in Figure 3-17 to configure your selected satellite(s).

TIP: For your convenience, you can determine your approximate latitude and longitude using the Position Grids provided in Appendix E on page 107.

Figure 3-17 Dual-Sat or Single Satellite Setup

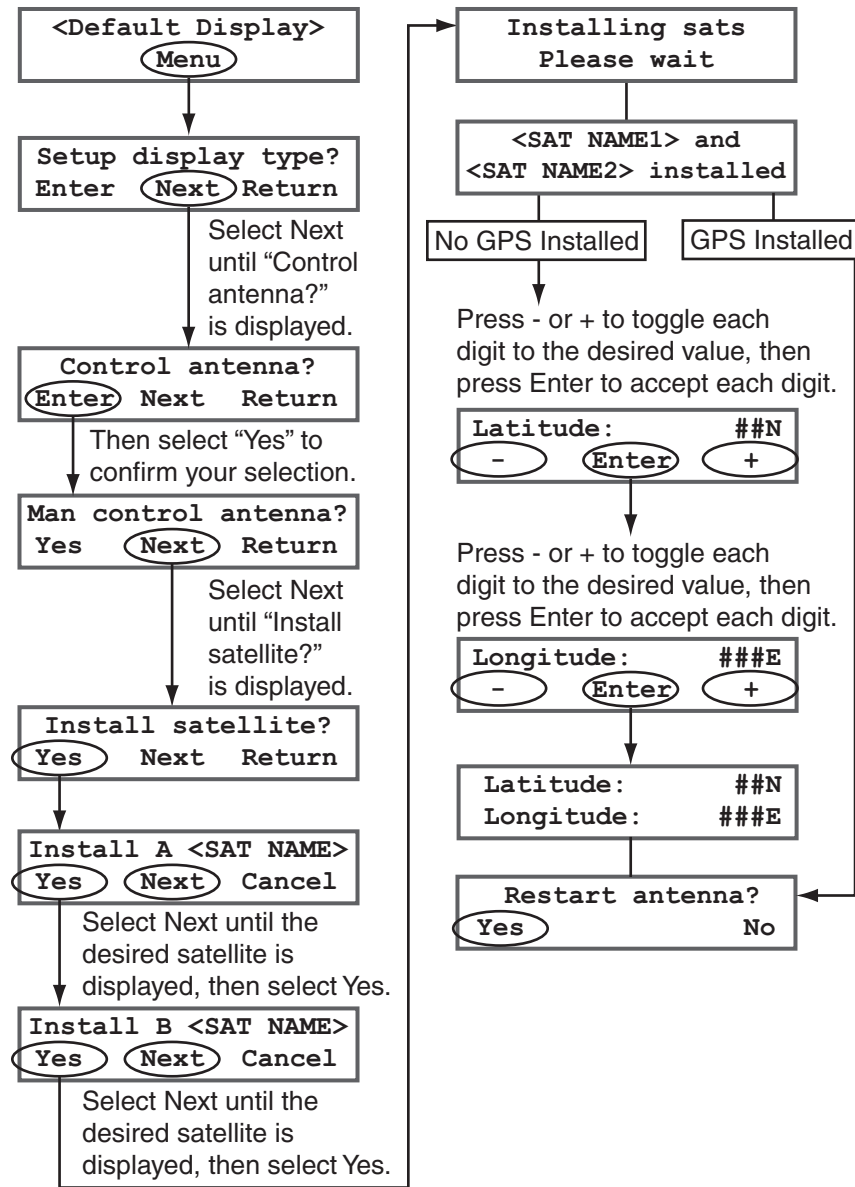

Step 3 - Configure the Receiver(s) (if required)

Linear configurations without a multiswitch, DISH Network, and ExpressVu subscribers require receiver configuration. The following sections explain how to configure the receiver(s) for TracVision use.

Linear Configurations

If your TracVision system does not include a multiswitch, you can configure the receivers to enable automatic switching. See “Linear Receiver Configuration” on page 25 for more information.

Circular Configurations

This section explains how to configure the TracVision system for DISH 500 or ExpressVu use. For operation instructions and additional information on DISH modes, refer to “Changing Channels and Switching Between Satellites (Circular Versions)” on page 15.

NOTE: *If you are connecting multiple receivers, repeat this process for each additional receiver. You will need to connect each receiver, one at a time, to the RF1 cable and perform the steps below. Then, once you have completed this process for each receiver, you can reconnect them as desired.*

1. Ensure the receiver you wish to configure is connected to the TracVision system's RF1 cable.
2. Apply operating power to the TracVision system. Then turn on the TV(s) and receiver(s). Wait until the tracking screen for your selected configuration is displayed.

Figure 3-18 Tracking Screen

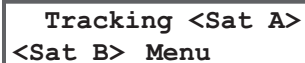
A rectangular box representing a tracking screen. The text inside the box is arranged in two lines: the first line reads "Tracking <Sat A>" and the second line reads "<Sat B> Menu".

```
Tracking <Sat A>
<Sat B> Menu
```

3. Using the receiver's remote, go to the “Point Dish/Signal Strength” screen (press MENU, 6, 1, 1 on most models).
4. Choose **Check Switch**, then press SELECT.
5. Choose **Test**, then press SELECT.

6. Wait at least 15 minutes before proceeding. Disregard messages on the TV stating the test is complete; you must wait 15 minutes before proceeding.

IMPORTANT!

Please be patient. The Check Switch test takes approximately 15 minutes to complete. Disregard any messages on the TV stating the test is complete; the antenna must perform additional operations before proceeding.

7. After waiting 15 minutes, repeat Steps 3-5 to run a second Check Switch test.

NOTE: Each Check Switch test takes approximately 15 minutes.

8. Verify the values on your TV match those required for your selected configuration (see Figures 3-19 and 3-20). If your values do not match, turn off the antenna, then turn it back on and repeat Steps 4-7.

Figure 3-19 DISH 500 Second Check Switch Results on TV Screen

Port	1	1	2	2
Satellite	119	119	110	110
Trans	Odd	Even	Odd	Even
Status	Reception Verified			
Switch	SW42			

Figure 3-20 ExpressVu Second Check Switch Results on TV Screen

Port	1	1	2	2
Satellite	91	91	82	82
Trans	Odd	Even	Odd	Even
Status	Reception Verified			
Switch	SW21			

9. Exit the menu and allow the receiver to download the program guide.

NOTE: You do not need to perform this procedure again unless you add another receiver or you reconfigure a receiver for home use.

European Tri-Sat Mode Setup

This section explains how to configure the TracVision system to track three satellites within predefined linear satellite groups for European locations (see Figure 3-21). For operation instructions, refer to “Changing Channels and Switching Between Satellites (Linear Versions)” on page 21.

Figure 3-21 European Tri-Sat Groups - Satellites/TracVision Position

Group Name	Satellites	Position
Europe WB	Hotbird WB	A
	Astra 1	B
	Astra 2S	C
Europe	Hotbird	A
	Astra 1	B
	Astra 2S	C
Scandinavia	Hotbird WB	A
	Sirius	B
	Thor	C

NOTE: To enable automatic switching, the receiver must be set up to match the TracVision system's satellite position settings (A, B, or C). Refer to “Linear Receiver Configuration” on page 25 for more information.

Step 1 - Configure the TracVision System

Follow the steps below to set up the TracVision system for your desired European Tri-Sat Mode. You will enter PC commands into the HyperTerminal window. An example is provided in Figure 3-22.

1. Connect a PC to the maintenance port, as described in "Connecting a PC" on page 40. You will enter the following PC commands into the HyperTerminal window.
2. Type **HALT** then press Enter.
3. Use the table below to enter the following **SATINSTALL** command then press Enter.

For Group:	Type:
Europe WB	SATINSTALL,TRISAT,EWB
Europe	SATINSTALL,TRISAT,EUR
Scandinavia	SATINSTALL,TRISAT,SCN

4. Type **ZAP** then press Enter to restart the antenna. Wait one minute for system startup.

Figure 3-22 Example, European Tri-Sat Mode - Europe WB Group

```

HALT
SATINSTALL,TRISAT,EWB
ZAP
    
```

Step 2 - Update Latitude and Longitude Data (if necessary)

If you do not have a GPS connected to the ADCU, you need to enter your vessel's latitude and longitude into the system.

Use the flowchart in Figure 3-23 to manually set the latitude and longitude values.

TIP: For your convenience, you can determine your approximate latitude and longitude using the Position Grids provided in Appendix E on page 107.

Figure 3-23 Setting Latitude and Longitude Manually

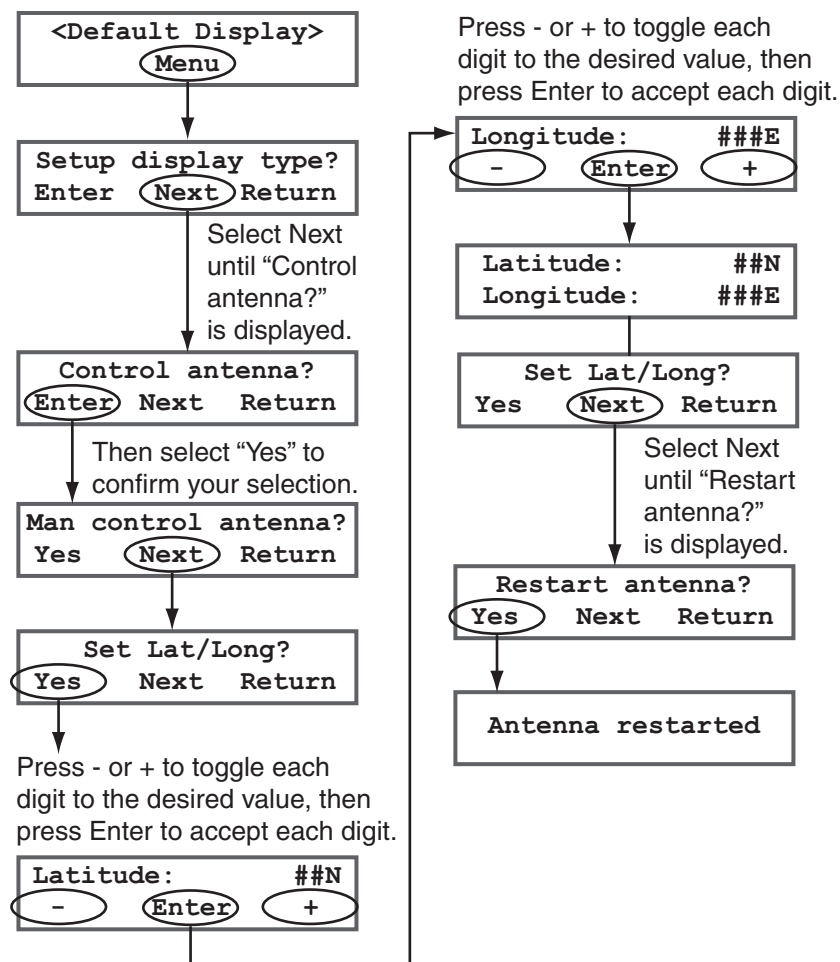

Step 3 - Adjust the LNB Skew Angle

Now that you have installed the desired Tri-Sat group, you need to adjust the antenna's LNB skew angle to optimize signal reception. Follow the instructions in "Setting the LNB Skew Angle (Linear Versions Only)" on page 34 to adjust the skew angle.

Setting Instant On Mode

When Instant On mode is enabled, the antenna can immediately receive signals on startup if the vessel has not moved since the antenna was last shut off. However, if the system is turned off, then the vessel moves after last acquiring the satellite via Instant On, the antenna will undergo its standard initialization process once it is turned back on, resulting in a brief delay.

NOTE: *Instant On is disabled by default and is not recommended for DISH Network or ExpressVu configurations.*

Use the flowchart in Figure 3-24 if you wish to enable Instant On mode, or if you wish to restore the original setting.

Figure 3-24 Enabling/Disabling Instant On Mode

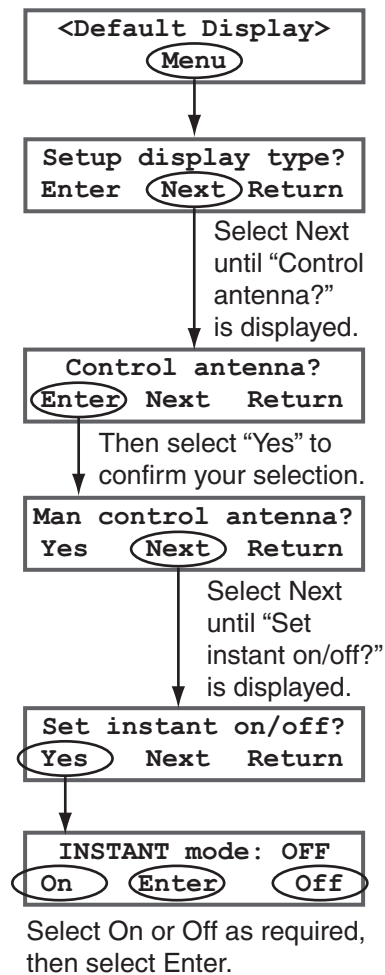

Setting Sleep Mode

When the vessel has come to a stop and holds its position for one minute (e.g., at a dock), the antenna unit enters Sleep Mode, which locks the antenna in place to conserve power. As soon as the vessel moves beyond a 1° - 2° window or the signal level changes significantly, Sleep Mode automatically turns off and the system begins tracking the satellite again (or enters Search Mode to find the satellite).

Use the flowchart in Figure 3-25 if you wish to disable Sleep Mode, or if you wish to restore the original Sleep Mode setting.

Figure 3-25 Setting Sleep Mode On/Off

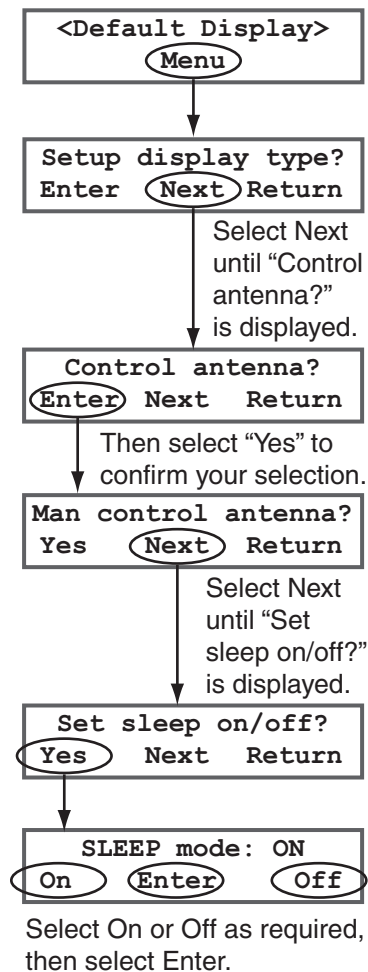

Adjusting Display Brightness

You can adjust the brightness of the ADCU's LCD screen to suit your preferences. Use the flowchart in Figure 3-26 if you wish to adjust the display brightness.

Figure 3-26 Setting Display Brightness

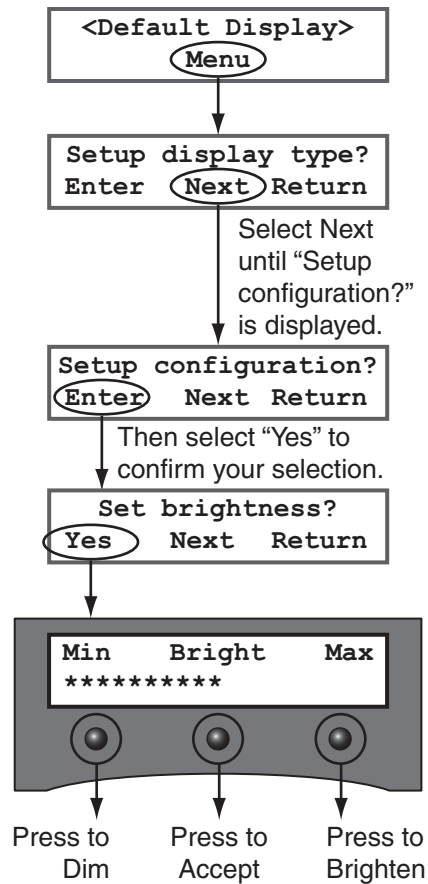

Restarting the TracVision System

Use the flowchart in Figure 3-27 if you wish to restart the TracVision system.

Figure 3-27 Restarting the TracVision System

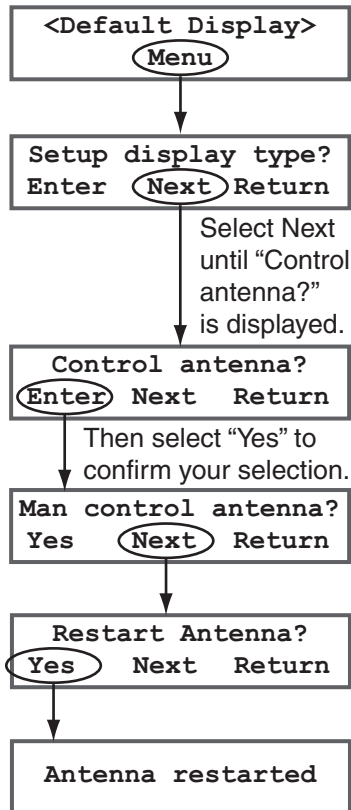



4. Troubleshooting

This chapter identifies potential basic problems along with their possible causes and solutions. It also explains how to get technical support.

Contents

Five Simple Checks	61
Error Messages	62
Troubleshooting Matrix.....	64
Causes and Remedies for Operational Issues	65
Technical Support.....	69





Five Simple Checks

If you are experiencing a problem receiving satellite TV with your TracVision system, perform the five simple checks below.

***TIP:** You can also try resetting the satellite TV receiver. Turn off and unplug the receiver, wait one minute, then plug it back in and turn it back on.*

Can the antenna see the satellite?

The antenna requires an unobstructed view of the sky to receive satellite TV signals. Common causes of blockage include boat masts, trees, buildings, bridges, and mountains.

Is there excessive dirt or moisture on the antenna dome?

Dirt buildup or moisture on the dome can reduce satellite reception. Clean the exterior of the dome periodically.

Is it raining heavily?

Heavy rain or snow can weaken satellite TV signals. Reception should improve once the inclement weather subsides.

Is everything turned on and connected properly?

Make sure your TV and receiver are both turned on and set up for the satellite input. Finally, check any connecting cables to ensure none have come loose.

(Linear Versions Only) Is the antenna's LNB set to the correct skew angle?

To optimize reception, the antenna's LNB needs to be set to the correct skew angle for the satellite(s) you want to track. See "Setting the LNB Skew Angle (Linear Versions Only)" on page 34 for details.

Error Messages

This section describes potential error messages displayed on the ADCU.

No GPS Data While System Powerup

The “No GPS data while system powerup” message is not a true error message. This indicates that no GPS was detected during TracVision M5/M7 initialization. If no GPS receiver is connected, or if the GPS receiver was not initialized prior to turning on the TracVision system, some navigational display types will be unavailable.

***TIP:** For information on ADCU display types, refer to “ADCU Display Types” on page 26.*

If a GPS receiver is connected but was not initialized prior to turning on the TracVision system, simply turn off the TracVision system, initialize the GPS receiver, then turn the TracVision system back on. The TracVision system will detect the GPS sensor during initialization. Refer to “Turning the System On/Off” on page 14 for more information.

Antenna Response Incorrect

The “Antenna response incorrect” error message indicates that the ADCU received an incorrect response from the antenna when requesting data. To correct this, simply repeat the requested operation.

Antenna Not Responding

The “Antenna not responding” error message indicates a communication failure between the ADCU and the antenna. This is usually the result of either the antenna being disconnected from the ADCU or the antenna not being turned on. If the antenna is intentionally turned off, switch to one of the navigational display types to use the navigational displays.

***TIP:** For information on ADCU display types, refer to “ADCU Display Types” on page 26.*



TV Comms is Off No Data from Antenna

The “TV comms is off no data from antenna” error message indicates a communication failure between the ADCU and the antenna. This is usually the result of either the antenna being disconnected from the ADCU or the antenna not being turned on. If the antenna is not intentionally turned off, check for loose cable connections or restart the system. For more information on restarting the system, refer to “Restarting the TracVision System” on page 58.

Troubleshooting Matrix

The troubleshooting matrix in Figure 4-1 identifies potential operational symptoms and their causes and remedies. “Causes and Remedies for Operational Issues” on page 65 contains detailed information on the causes and remedies listed below.

Figure 4-1 Troubleshooting Matrix

SYMPTOM	CAUSES AND REMEDIES										
	Receiver fault or improper receiver configuration	Satellite coverage issue	Satellite signal blocked	Radar interference	Satellite frequency	Vessel turning during startup	Insufficient power	Improper wiring	Loose RF connectors	Type of multiswitch used	Cable unwrap
Antenna non-functional							x	x			
Antenna not switching satellites	x	x	x				x	x	x	x	
No picture on TV set	x	x	x	x	x			x	x	x	
Certain channels do not work	x	x	x		x		x	x	x		
Intermittent picture for short intervals		x	x	x		x			x	x	x
System works at dock but not on the move			x			x					
System will not find satellite	x	x	x	x	x	x	x	x	x	x	
Snowy television picture	x						x	x	x		
Pixelating television picture	x	x	x	x		x	x	x	x		

Causes and Remedies for Operational Issues

This section addresses the most common operational issues that can affect the performance of the TracVision M5/M7 system. If your TracVision system requires service, you can visit any KVH-authorized dealer or distributor for assistance. To find a KVH-authorized dealer near you, visit www.kvh.com/wheretogetservice.

Receiver Fault or Improper Receiver Configuration

Receiver Fault

Your satellite TV receiver might be set up incorrectly or defective. First check the receiver's configuration to ensure it is set up for the desired programming. In the case of a faulty receiver, refer to your selected receiver's user manual for service and warranty information.

Improper Receiver Configuration (Linear Versions Only)

To enable automatic satellite switching, the receiver(s) must be set up for the same satellites, and in the same order, they are set up in the antenna.

NOTE: Linear TracVision systems with a multiswitch installed require manually switching satellites using the ADCU, which does not require receiver configuration.

TracVision Satellite	Receiver Satellite	DiSEqC Setting
Satellite A	Alternative 1 or A	DiSEqC 1
Satellite B	Alternative 2 or B	DiSEqC 2
Satellite C*	Alternative 3 or C	DiSEqC 3

***NOTE:** Only European Tri-Sat configurations track three satellites.

Satellite Coverage Issue

Television satellites are located in fixed positions above the Earth's equator and beam TV signals down to certain regions of the planet (not worldwide). To receive TV signals from a satellite, you must be located within that satellite's unique coverage area.

TIP: For your convenience, KVH provides links to several websites that offer satellite coverage information. Simply visit our website at www.kvh.com/footprint.

Figure 4-2 Location and Coverage Area of DIRECTV 101 Satellite

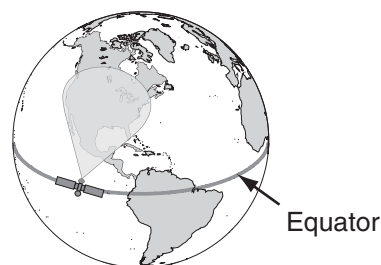

Satellite Signal Blocked

Since TV satellites are located above the equator, the TracVision antenna must have a clear view of the sky to receive satellite TV signals. Anything that stands between the antenna and the satellite can block the signal, resulting in lost reception. Common causes of blockage include boat masts, trees, buildings, and bridges. Heavy rain, ice, or snow might also temporarily interrupt satellite signals.

Figure 4-3 Example of Satellite Blockage

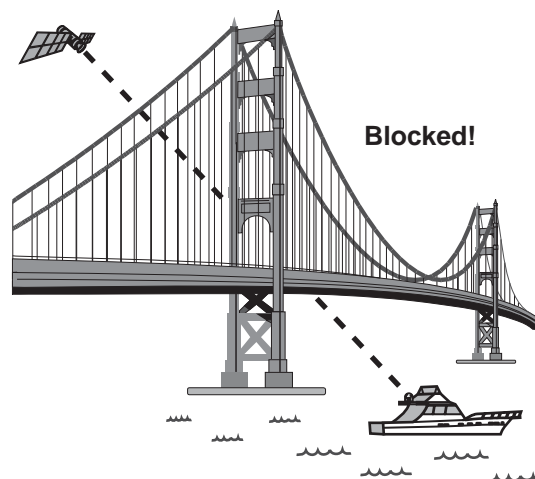



Radar Interference

The TracVision M5/M7 antenna must be kept out of line with nearby radars, as their energy levels might overload the antenna's front-end circuits. Refer to the TracVision M5/M7 Installation Guide for details, or visit any KVH-authorized dealer or distributor for assistance. To find a KVH-authorized dealer near you, visit www.kvh.com/wheretogetservice.

Satellite Frequency Data Changed

If some channels work, while one or more other channels do not, or if the antenna cannot find the selected satellite, the satellite's frequency data might have changed. You can visit any KVH-authorized dealer or distributor for assistance. To find a KVH-authorized dealer near you, visit www.kvh.com/wheretogetservice.

Vessel Turning During Startup

If you turn the vessel during the first minute after system startup, the gyro calibration that occurs during startup might become invalid, causing the TracVision M5/M7 system to track improperly. To solve this problem, simply turn off the TracVision M5/M7 system for at least ten seconds. Then turn on the TracVision system, ensuring the vessel is either motionless or traveling in a straight line for the first minute after startup.

Insufficient Power

If the power cable to the antenna unit is more than 50 ft (15 m) long, the power level can decrease over the length of the cable, resulting in a voltage level at the antenna that is too low to power the system. Refer to the TracVision M5/M7 Installation Guide for details on supplying adequate power to the antenna, or visit any KVH-authorized dealer or distributor for assistance. To find a KVH-authorized dealer near you, visit www.kvh.com/wheretogetservice.

Improper Wiring

If the system has been improperly wired, the antenna will not operate correctly. Refer to the wiring diagrams provided in Appendix C on page 97. You can also refer to the TracVision M5/M7 Installation Guide for complete system wiring information, or visit any KVH-authorized dealer or distributor for assistance. To find a KVH-authorized dealer near you, visit www.kvh.com/wheretogetservice.

Loose RF Connectors

KVH recommends that you periodically check the system's cable connections. A loose RF connector can reduce signal quality or prevent automatic satellite switching using the receiver's remote control. Refer to the TracVision M5/M7 Installation Guide for complete system wiring information, or visit any KVH-authorized dealer or distributor for assistance. To find a KVH-authorized dealer near you, visit www.kvh.com/wheretogetservice.

Type of Multiswitch Used

If your TracVision system's configuration requires a multiswitch, an active (powered) multiswitch must be used to ensure proper antenna performance. Refer to the wiring diagrams in Appendix C on page 97 for detailed information.

Cable Unwrap

If your vessel makes several consecutive circles in the same direction, the antenna will rotate 720° before reaching the end of its internal cable. If this occurs, the system will automatically unwrap the cable by quickly rotating the antenna dish in the opposite direction. During this time, your TV picture will freeze momentarily.

Technical Support

The TracVision M5/M7 antenna is a sophisticated electronic device. KVH-authorized technicians have the specialized tools and expertise necessary to diagnose and repair a system fault. Therefore, if you experience any operating problem or require technical assistance, please call or visit your local authorized TracVision dealer or distributor. To find a KVH-authorized dealer near you, visit www.kvh.com/wheretogetservice.

If you need help finding an authorized technician, please contact KVH Technical Support:

North/South America, Australia:

Phone: +1 401 847-3327

E-mail: techs@kvh.com

(Mon.-Fri., 9 am-6 pm ET, -5 GMT)

(Sat., 9 am-2 pm ET, -5 GMT)

Europe, Middle East, Asia:

Phone: +45 45 160 180

E-mail: support@kvh.dk

(Mon.-Fri., 8 am-4:30 pm, +1 GMT)

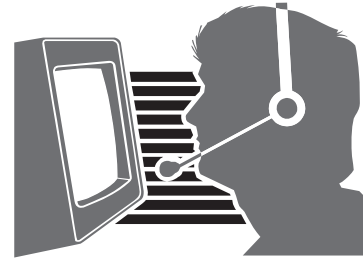

Please have your antenna serial number handy before you call (see “Displaying the Antenna Serial Number” on page 83 for more information).



Appendix A Advanced Settings and Functions

This appendix contains information on advanced settings and functions.
This information should only be utilized by KVH-authorized technicians.

Contents

Data Output Settings	73
Setting the Heading Reference Source	77
Manually Controlling the Antenna	78
Updating Satellite Frequency Data	79
Displaying the Calibration Score	81
Displaying the Antenna Software Version	82
Displaying the Antenna Serial Number	83



Data Output Settings

This section explains how to modify the GyroTrac sensor's data output settings.

Overview

The TracVision system's GyroTrac sensor transmits up to five selectable message types simultaneously to external navigation devices connected to the ADCU. One output port is dedicated to the sine/cosine signal format. Three serial ports allow outputs of NMEA 0183, KVH RS-422, and Cetrek proprietary signal formats. Each of these message formats are described in the following sections.

Sine/Cosine Data Output

The TracVision system's GyroTrac sensor can be configured to provide either 3-wire or 4-wire sine/cosine output, but not both. The sine/cosine output is commonly used in ComNav[®], Robertson[®], and other autopilot systems.

TIP: *The B&G 4-wire sine/cosine output (also known as the "differential sine/cosine") is a substitute of the Halcyon compass output. The reference voltage should be set to 3.5 volts.*

NOTE: *The maximum current that can be drawn from the sine/cosine output is 10 mA.*

Sine/cosine setup requires the following to be selected:

- Magnetic or true heading
- Reference voltage (valid range is 0 - 6.5 volts, default value is 2.5 volts)
- Swing voltage (valid range is 0 - 6.5 volts, default value is ± 1.67 volts)

Use the flowchart in Figure A-1 to modify the sine/cosine data output settings, or restore the original sine/cosine settings.

NOTE: If an active GPS connection is not detected, "Only Mag Available" is displayed. If the ADCU is receiving data from an external gyro, all compass outputs are automatically configured as True North, causing "Only True Available" to be displayed.

Figure A-1 Sine/Cosine Data Output Settings

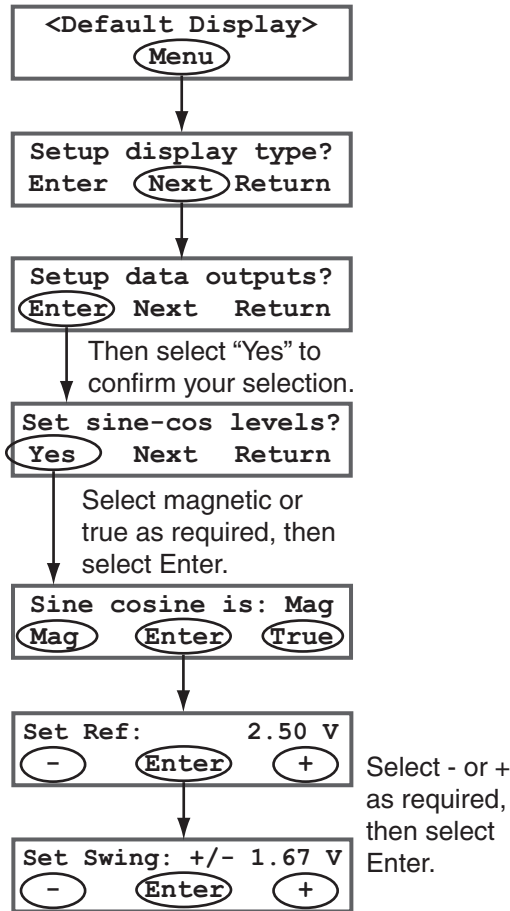

Serial Port Outputs

Serial ports 1 and 2 can be individually programmed to output any of the message formats described in this section (serial port 3 is disabled when a TracVision system is connected to the ADCU). Up to four NMEA 0183 listening devices can be connected to each of the serial ports. Serial port 1 also has a pass-through duplicate port.

Each serial port can be independently programmed to output data at a rate from 1 Hz to 20 Hz, selectable in 1 Hz increments. The default data rate is 10 Hz.

***NOTE:** Serial port 3 is disabled. If serial port 3 is selected, the “No Port 3 TV Setup” screen will be displayed. Press any key to exit the screen.*

Message Formats

NMEA

The NMEA message format conforms to the NMEA 0183 version 2.20 standard for message structure. The following NMEA outputs can be selected: BWC, GGA, GLL, HDG, HDM, HDT, VTG, and XTE.

***NOTE:** The data rate of serial port 1 is 4800 baud; the default data rate of serial port 2 is 9600 baud. However, if serial port 2 is selected for NMEA output, the baud rate is automatically changed to 4800 baud.*

KVH RS-422

The KVH message format is an RS-422 message format giving stabilized pitch, roll, and yaw data. Data output from port 1 will be 4800 baud, while data port 2 will be 9600 baud; this message can be used for any device that is able to receive this data rate.

Cetrek Proprietary

The Cetrek proprietary message format is a stabilized heading output for use with Cetrek autopilot systems. If an active GPS connection is detected, you can select either magnetic or true heading.

Use the flowchart in Figure A-2 to modify the serial output settings, or if you wish to restore the original output settings.

Figure A-2 Serial Output Settings

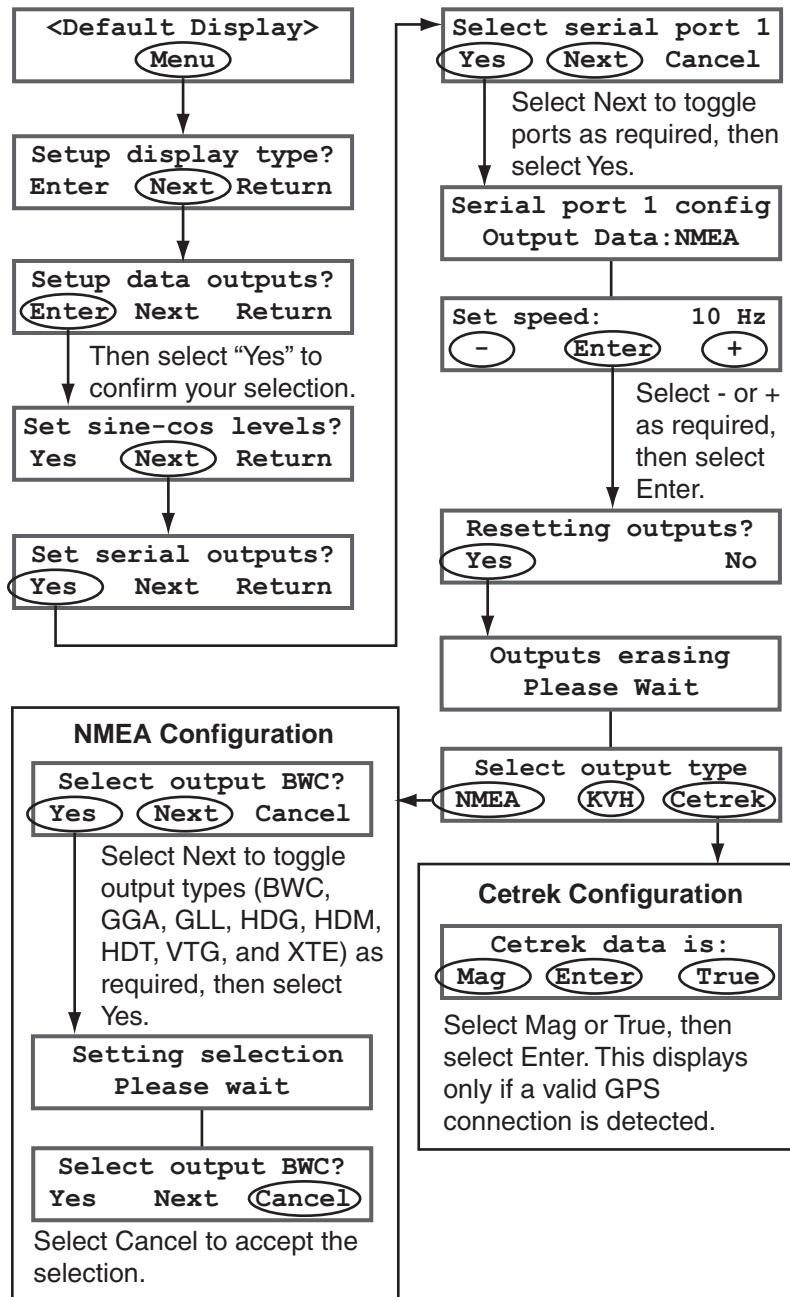

Setting the Heading Reference Source

You can set the heading reference source to internal (default) or external. When internal heading data is selected, the system receives heading data from the GyroTrac's sensor. You can select external heading data if an external compass is connected to the system.

Use the flowchart in Figure A-3 to modify the heading reference source.

Figure A-3 Setting the Heading Reference Source

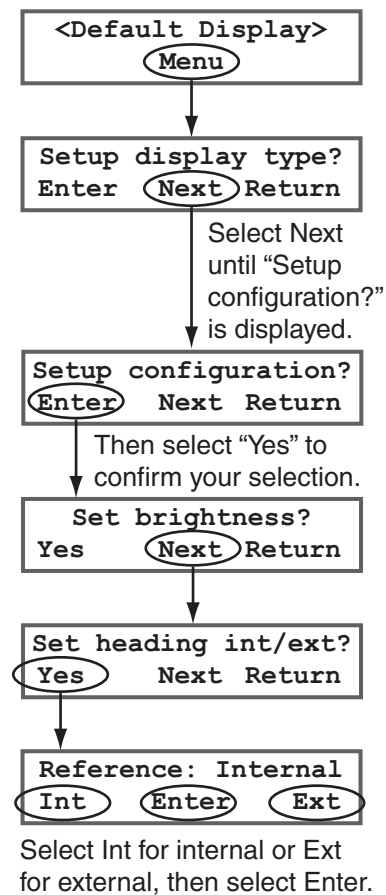

Manually Controlling the Antenna

Use the flowchart in Figure A-4 if you wish to manually control the antenna.

NOTE: If you are performing this procedure as part of a satellite frequency scan update procedure, be sure to select "NO" at the "Make Antenna Track" screen.

TIP: Once you have finished positioning the antenna, the system will revert to automatic control.

Figure A-4 Manually Controlling the Antenna

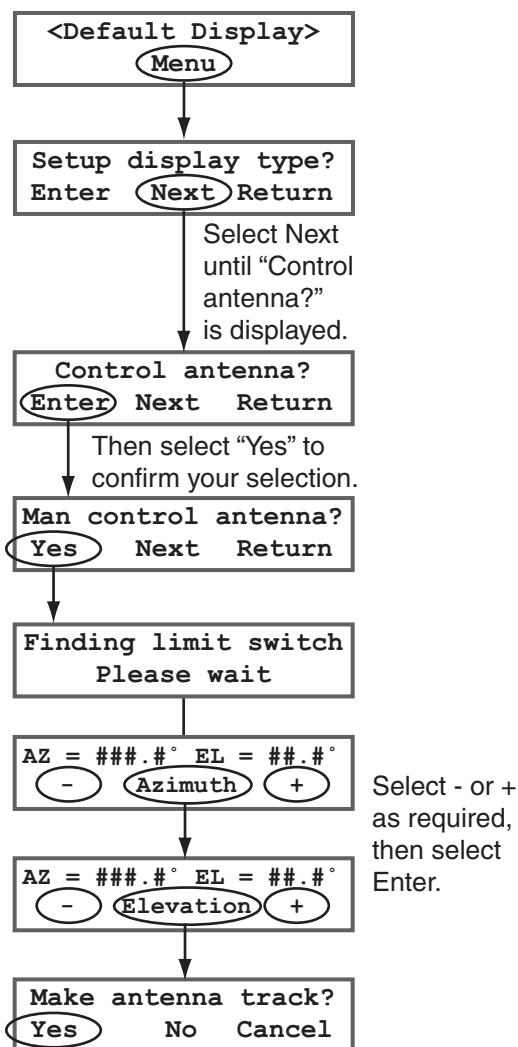

Updating Satellite Frequency Data

If the antenna is unable to find a satellite, or if you are unable to receive certain channels, the satellite's frequency data might have changed. The satellite frequency scan feature allows you to update the frequency data of any satellite stored in the system's library.

With the desired satellite, band, and polarization selected, the system will automatically search for the frequency with the strongest signal. The system will then update that satellite's programmed data with the new frequency (and associated network ID) and store it in the satellite library.

You will need to enter the following information:

- Symbol rate
- FEC code

TIP: You can find satellite information on the web at www.lyngsat.com or www.satcodx.com (neither website is affiliated with KVH).

To update the satellite frequency data, follow the steps below.

IMPORTANT!

The vessel must remain stationary throughout this procedure.

1. Track the satellite you wish to update by choosing a valid polarization/band.
2. Set your satellite receiver to signal meter mode. Refer to your selected receiver's user manual for details.
3. Ensure your TV signal meter indicates that you have a strong signal.
4. Using the receiver, select the desired polarization and band you wish to update. Refer to your selected receiver's user manual for details.

- Use the flowchart in Figure A-5 to scan the frequency data of the selected satellites.

TIP: Scanning satellite frequencies might take up to 10 minutes.

Figure A-5 Scanning Frequency Data

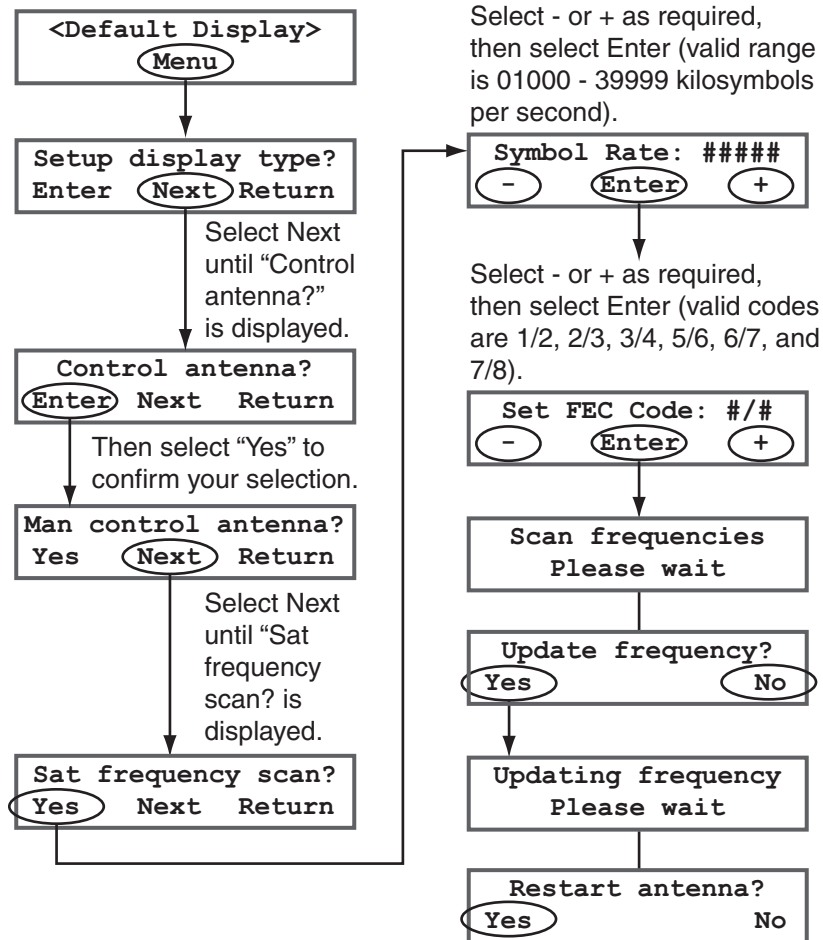

Displaying the Calibration Score

Use the flowchart in Figure A-6 to display the calibration score. For information on interpreting the calibration score, see “Interpreting the Calibration Score” on page 92.

IMPORTANT!

If the system is currently configured to use an external compass, you must set the TracVision system to use an internal heading reference before performing this procedure. See “Setting the Heading Reference Source” on page 77 for more information.

Figure A-6 Displaying the Calibration Score

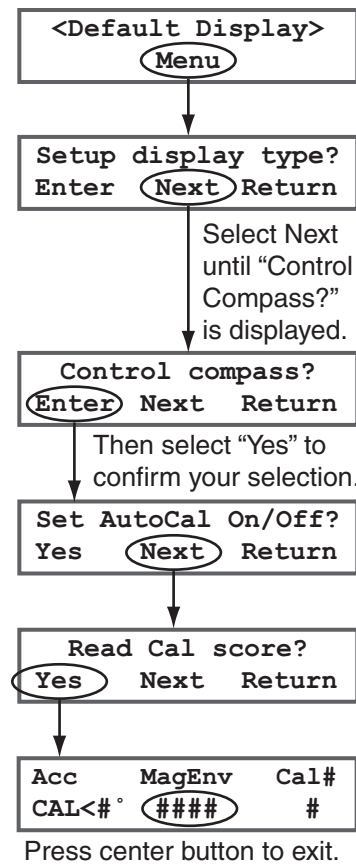

Displaying the Antenna Software Version

Use the flowchart in Figure A-7 if you wish to display the antenna software version.

Figure A-7 Displaying the Antenna Software Version

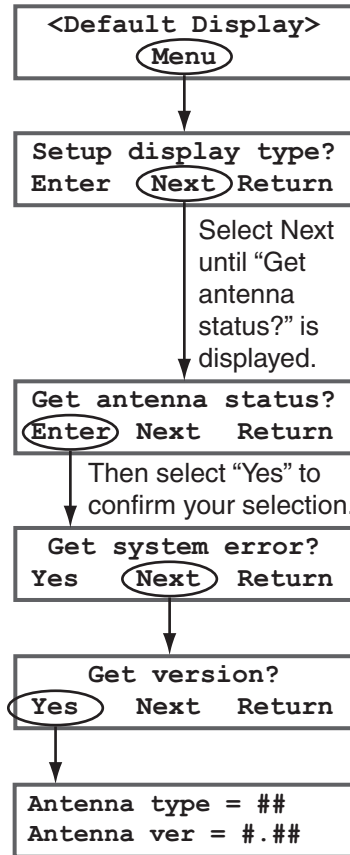

Displaying the Antenna Serial Number

Use flowchart in Figure A-8 if you wish to display the antenna serial number.

Figure A-8 Displaying the Antenna Serial Number

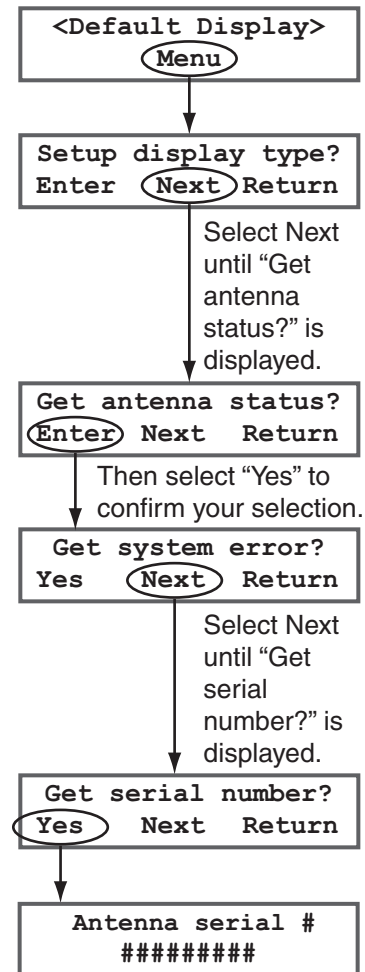



Appendix B Recalibration

This appendix explains how to recalibrate the system and set gyro offset values. This information should only be utilized by KVH-authorized technicians.

Contents

Recalibrating the System	87
Setting the Sensor Offset Values	94





Recalibrating the System

During installation, the TracVision M5/M7 system should have been properly calibrated. However, if the GyroTrac sensor is moved to another location, or if additional metallic equipment is installed or removed near the GyroTrac sensor, KVH recommends recalibrating the system. This section explains how to recalibrate the system.

To perform this procedure, you will need to perform the following:

- Clear the existing calibration score
- Turn on autocalibration
- Recalibrate the system
- Verify the calibration score
- Turn off autocalibration

IMPORTANT!

If the system is currently configured to use an external compass, you must set the TracVision system to use an internal heading reference before performing this procedure. See “Setting the Heading Reference Source” on page 77 for more information.

Step 1 - Clear the Existing Calibration Score

Use the flowchart in Figure B-1 to clear the existing calibration score.

NOTE: If the “System Halted Power System Off/On” message is displayed during this procedure, turn the system off, wait 10 seconds, then turn the system on. Wait one minute for initialization before restarting the procedure.

NOTE: Be sure to turn the system off after completing this procedure. Wait 10 seconds, then turn the system on.

Figure B-1 Clearing the Existing Calibration Score

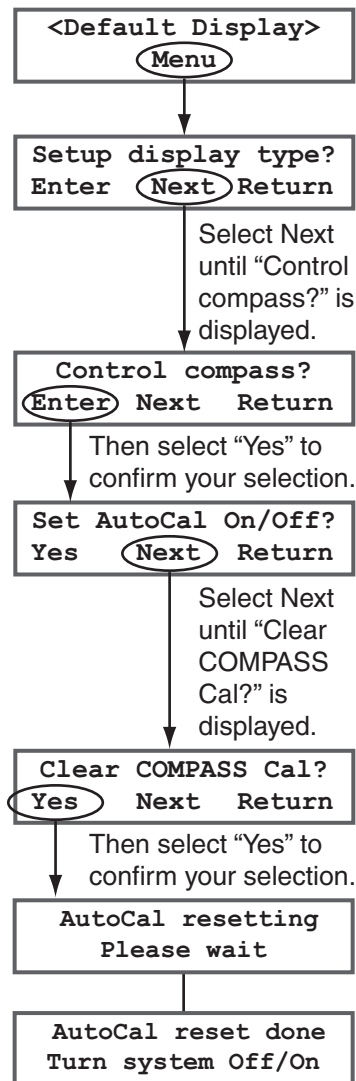

Step 2 - Set Autocalibration to On

Use the flowchart in Figure B-2 to turn on autocalibration.

Figure B-2 Setting Autocalibration to On

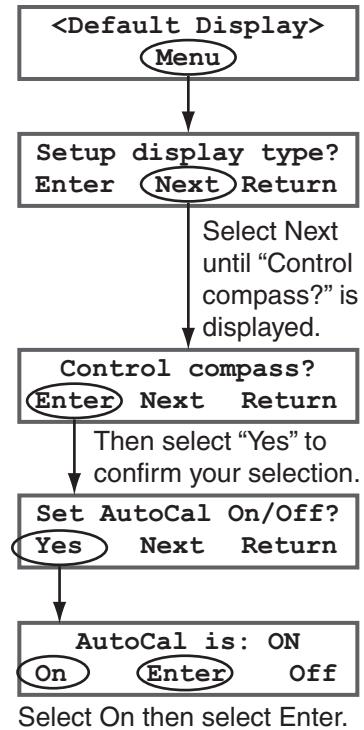

Step 3 - Recalibrate the System

- a. Select a calm day and a clear area. Excessive pitching and rolling can distort calibration data.
- b. Write down your approximate heading. You will use this information later in this procedure.
- c. Steer the vessel at a slow, steady speed through two full circles that take at least two minutes each to complete. Use the heading information you recorded earlier to confirm that you completed each full circle (see Figure B-3).

TIP: The circles do not have to be perfectly round, but ensure that you have turned 360° for each circle.

Figure B-3 Timing Calibration Circles

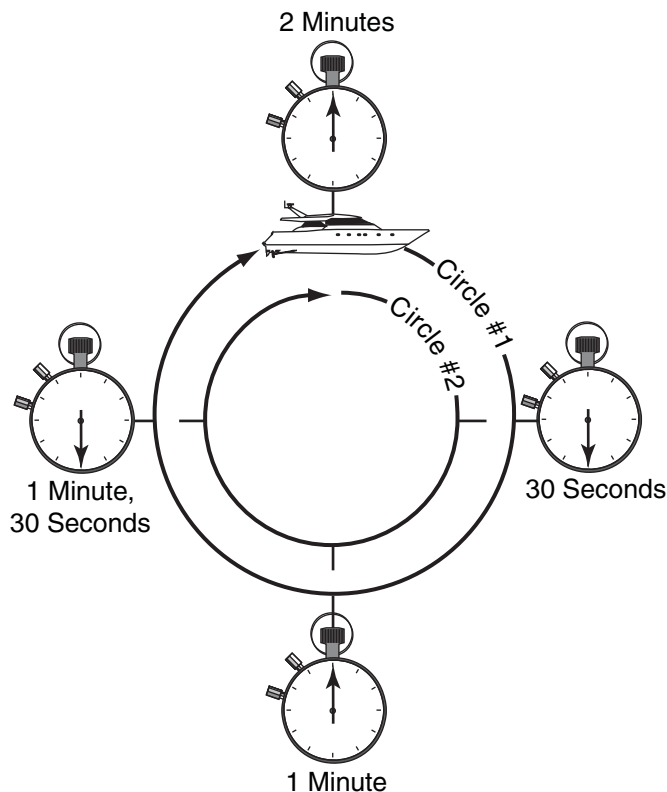

Step 4 - Verify the Calibration Score

This section explains how to display and interpret the calibration score. Be sure to verify that the calibration yielded acceptable results. If the calibration did not yield acceptable results, you will need to restart recalibration.

Displaying the Calibration Score

Use the flowchart in Figure B-4 to display the calibration score.

Figure B-4 Displaying the Calibration Score

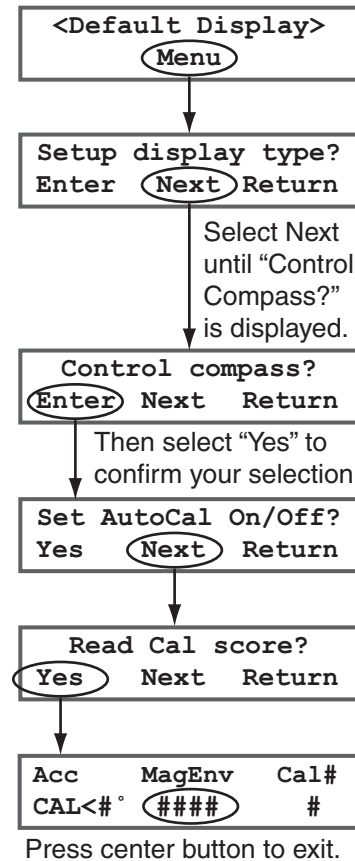

Interpreting the Calibration Score

Each calibration results in a calibration score that is stored in the system's memory. The calibration score contains an accuracy rating, a magnetic environment rating, and the number of calibrations performed.

Figure B-5 Calibration Score Screen

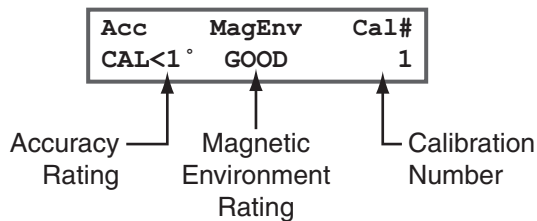

Accuracy Rating

The accuracy rating indicates the degree of accuracy the GyroTrac will provide based on the quality of the last calibration. Figure B-6 lists five possible accuracy rating levels.

Figure B-6 Accuracy Rating Levels

Accuracy Rating	Accuracy
<1°	Better than 1°
<2°	Better than 2°
<4°	Better than 4°
<8°	Better than 8°
BAD CAL	Recalibrate

Magnetic Environment

The magnetic environment rating (GOOD, POOR, BAD) indicates the quality of the installation location. If the quality is POOR or BAD, the GyroTrac sensor should be moved to a more favorable magnetic environment and recalibration should be restarted.

Calibration Number

The calibration number indicates the number of times the sensor has been calibrated. This is primarily used to verify that a new calibration has been accepted by the system.

Step 5 - Set Autocalibration to Off

Use the flowchart in Figure B-7 to turn off autocalibration.

Figure B-7 Setting Autocalibration to Off

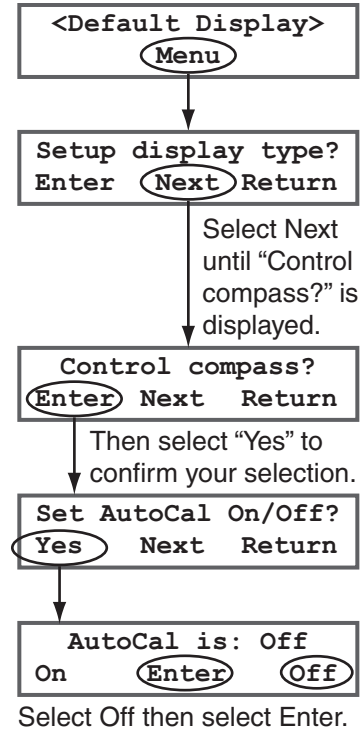

Setting the Sensor Offset Values

The GyroTrac sensor must be mounted as close to level in pitch and roll as possible, with its long axis parallel to the vessel's centerline. If the GyroTrac sensor was not mounted according to the guidelines in the Installation Guide, you need to adjust the sensor offset values to compensate for variances when pitch, roll, and azimuth references cannot be met.

NOTE: The maximum offset values for pitch and roll are $\pm 45^\circ$; the maximum offset value for azimuth is $\pm 180^\circ$.

NOTE: Pitch, roll, and yaw settings are determined by the GyroTrac sensor, not external hardware.

Step 1 - Zero All Offset Values

Use the flowchart in Figure 3 on page 95 to enter zeros for all measurements.

Step 2 - Record the Difference in Offset Values

Now you need to record the difference in the offset values displayed. Navigate to the Pitch, Roll, and Yaw display. Then record the values displayed for pitch, roll, and yaw (see "Pitch, Roll, and Yaw" on page 27 for more information).

Step 3 - Enter Inverse Offset Values

Use the flowchart in Figure 3 on page 95 to enter the inverse values for the measurements you recorded earlier (positive becomes negative, negative becomes positive). An example of offset value compensation is provided in Figure B-8.

Figure B-8 Example of Offset Compensation

For Recorded Offset:	Enter Offset:
-10.0°	10.0°
12.6°	-12.6°

Figure 3 Setting Sensor Offset Values

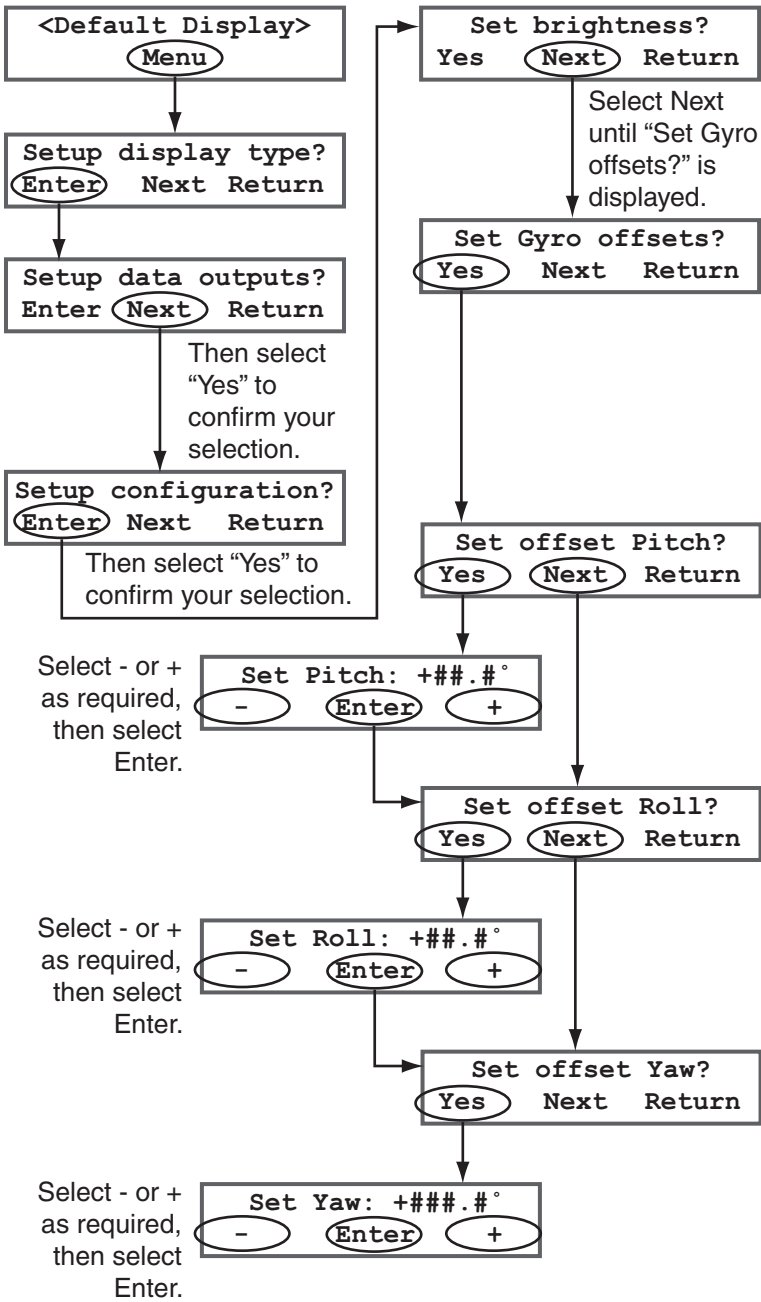



Appendix C

Receiver Wiring Diagrams

This appendix provides receiver wiring diagrams for basic configurations. Wiring diagrams vary according to the number of receivers installed and the TracVision system configuration (circular/linear and dual/quad-output). For installation instructions, refer to the Installation Guide.

Contents

Wiring Diagram for One or Two Receivers	99
Wiring Diagram for Three or Four Receivers (Circular Versions)	100
Wiring Diagram for Three or Four Receivers (Linear Quad-output Versions).....	101

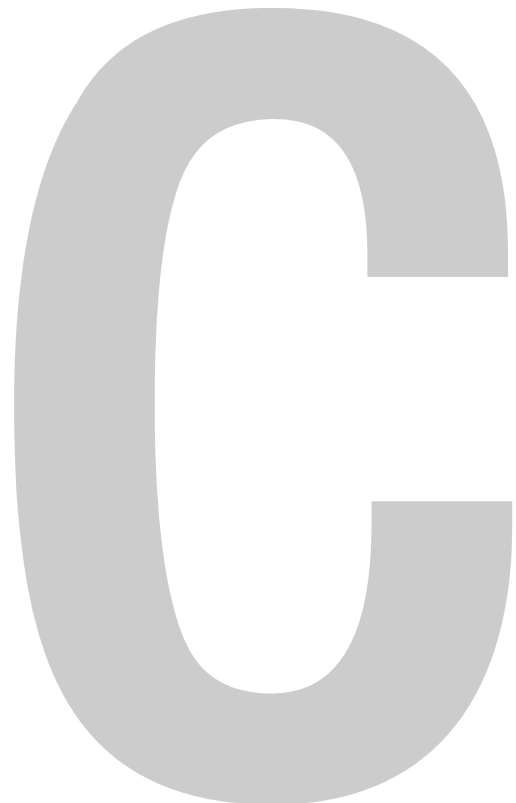

Wiring Diagram for One or Two Receivers

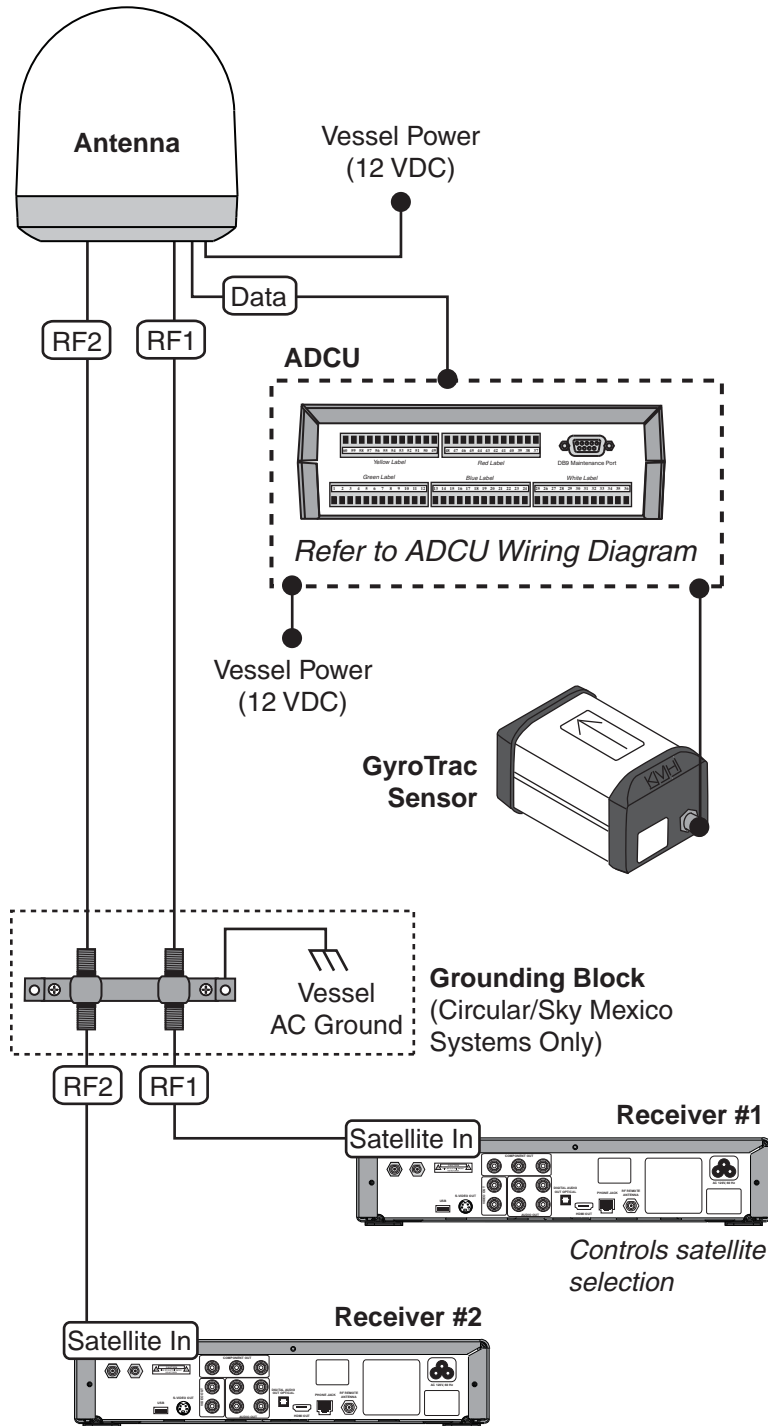

Circular Versions Only

Wiring Diagram for Three or Four Receivers (Circular Versions)*

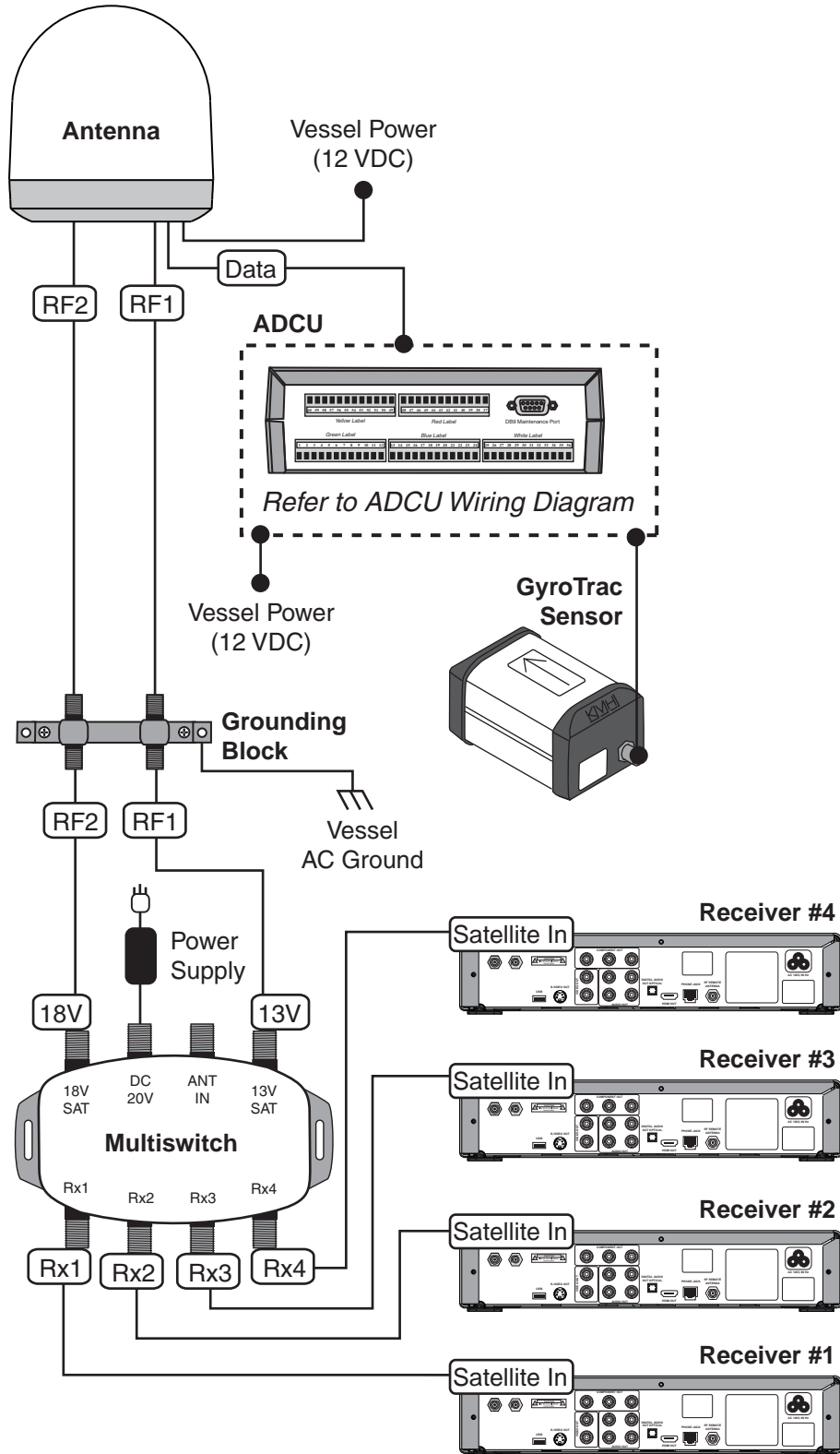

***NOTE:** Only the Eagle Aspen multiswitch (KVH Part #72-0310) is approved for this configuration.

Wiring Diagram for Three or Four Receivers (Linear Quad-output Versions)*

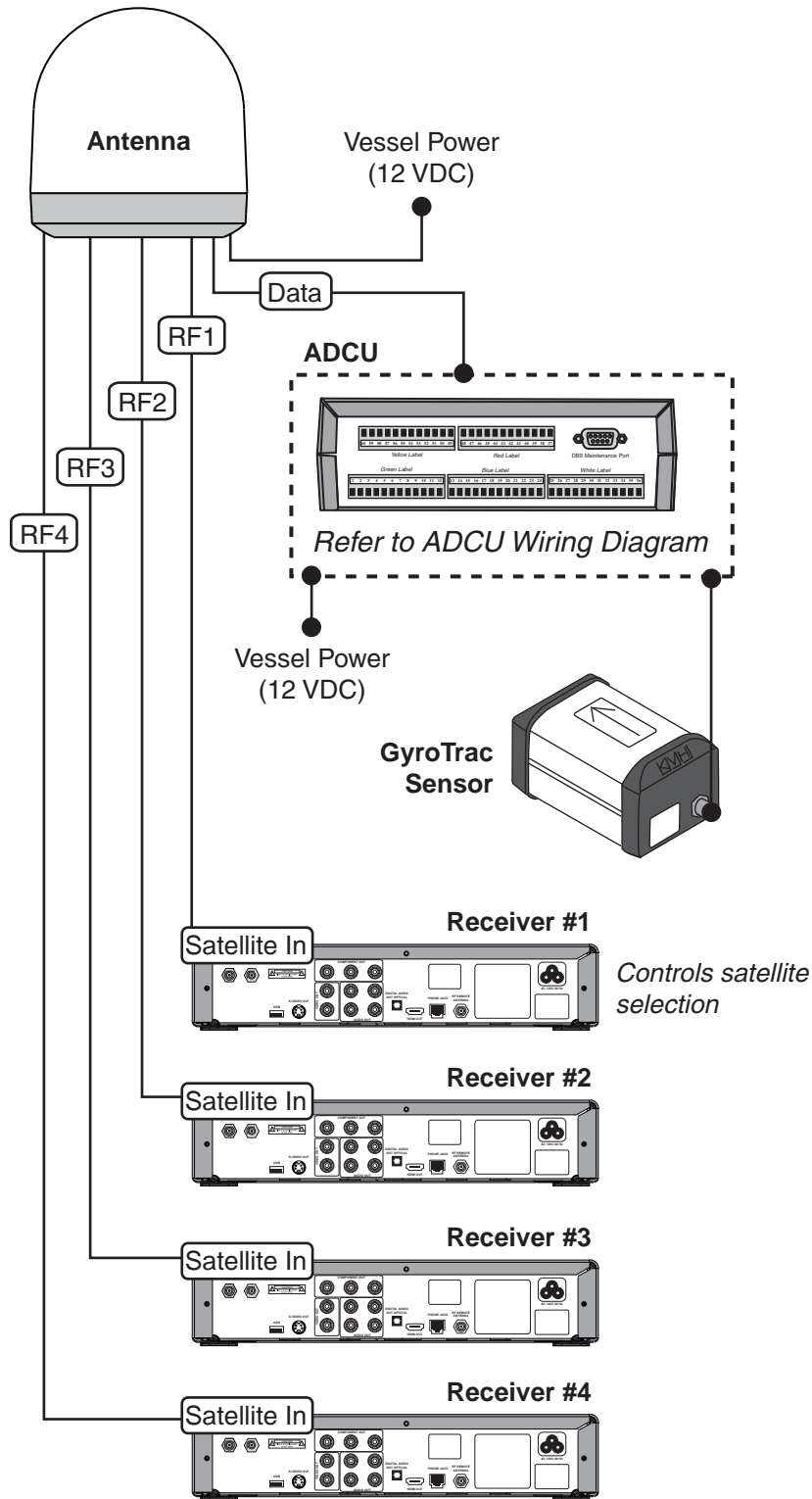

Linear Quad-output Versions Only

***NOTE:** If you wish to connect more than four receivers, you will need to install an active (powered) multiswitch, such as Spaun model SMS5602 NF. You can purchase this multiswitch from KVH (KVH Part #19-0413).



Appendix D

ADCU Wiring Diagrams

This appendix provides ADCU wiring diagrams for both required and optional equipment. For installation instructions, refer to the Installation Guide.

Contents

ADCU Wiring Diagram (Required)	105
ADCU Wiring Diagram (Optional Equipment)	106



ADCU Wiring Diagram (Required)

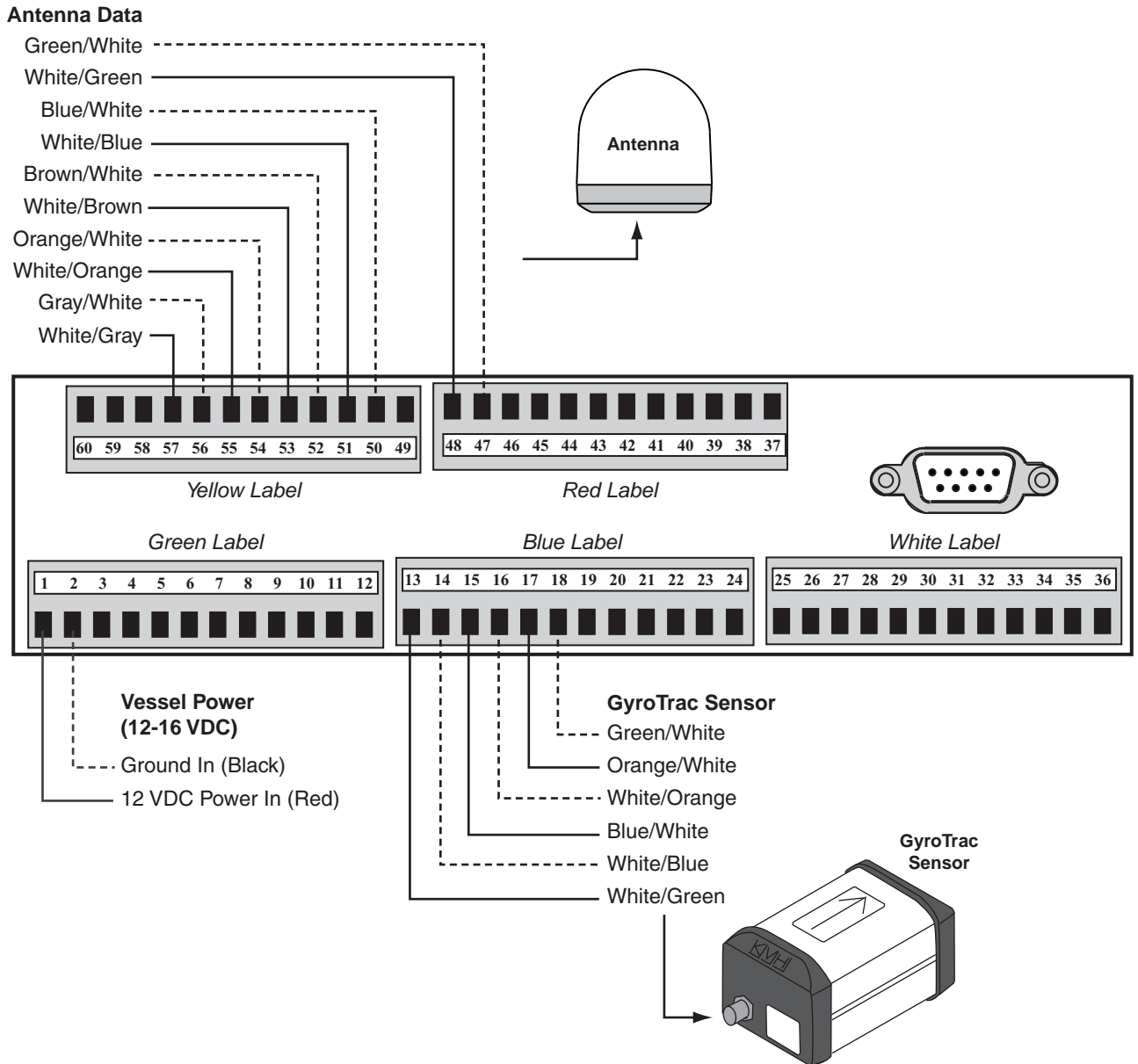

ADCU Wiring Diagram (Optional Equipment)

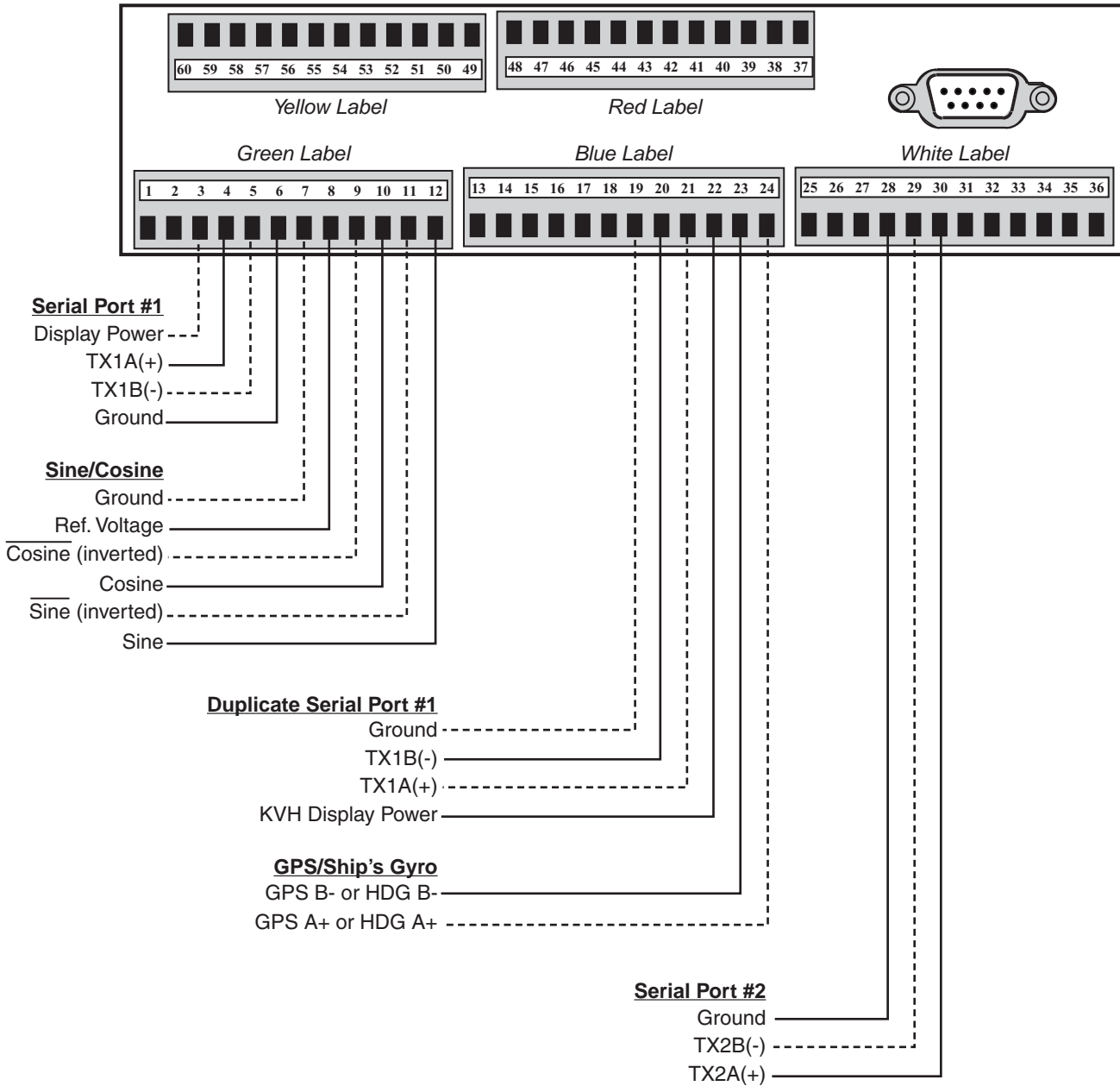



Appendix E Position Grids

This appendix contains European and North American position grids for determining your approximate latitude and longitude.

Contents

European Position Grid 109
North American Position Grid 110



European Position Grid

If you wish to determine your approximate latitude and longitude, use the position grid and table in Figure E-1.

Figure E-1 Approximate Latitude and Longitude

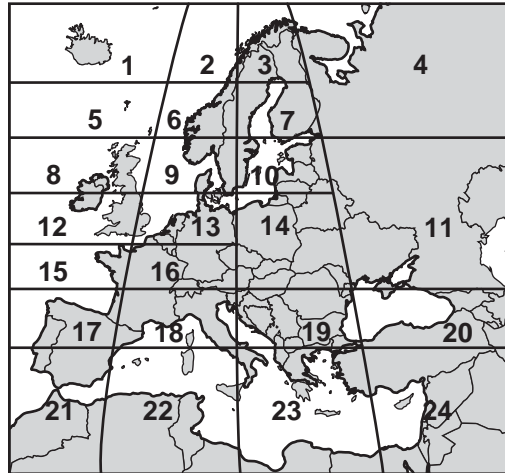

Grid #	Latitude	Longitude
1	67° N	7° W
2	67° N	7° E
3	67° N	22° E
4	65° N	45° E
5	63° N	7° W
6	63° N	7° E
7	63° N	22° E
8	57° N	7° W
9	57° N	7° E
10	57° N	22° E
11	55° N	40° E
12	53° N	7° W
13	53° N	7° E
14	50° N	22° E
15	47° N	7° W
16	47° N	7° E
17	43° N	7° W
18	43° N	7° E
19	43° N	22° E
20	43° N	37° E
21	36° N	7° W
22	36° N	7° E
23	36° N	22° E
24	36° N	37° E

North American Position Grid

If you wish to determine your approximate latitude and longitude, use the position grid and table in Figure E-2.

Figure E-2 Approximate Latitude and Longitude

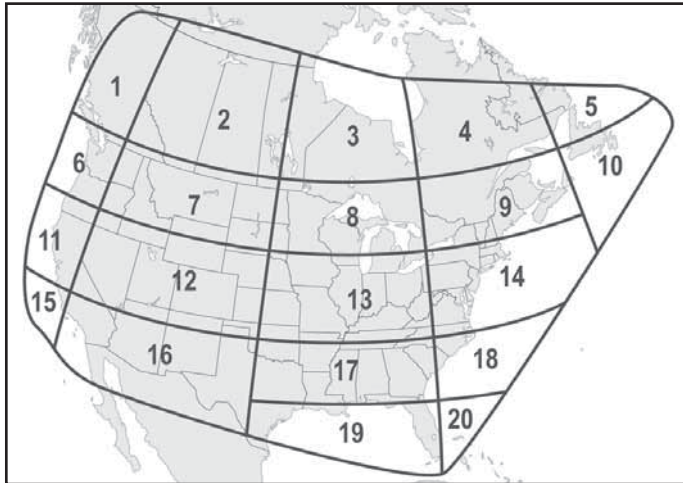

Grid #	Latitude	Longitude
1	55° N	125° W
2	55° N	110° W
3	55° N	90° W
4	55° N	70° W
5	55° N	55° W
6	45° N	125° W
7	45° N	110° W
8	45° N	90° W
9	45° N	70° W
10	45° N	50° W
11	40° N	125° W
12	40° N	110° W
13	40° N	90° W
14	40° N	70° W
15	32° N	125° W
16	32° N	110° W
17	32° N	90° W
18	32° N	75° W
19	27° N	83° W
20	27° N	78° W



www.kvh.com



KVH Industries A/S
EMEA Headquarters
Kokkedal, Denmark
Tel: +45 45 160 180 Fax: +45 45 160 181
E-mail: info@emea.kvh.com

KVH Industries, Inc.
World Headquarters
Middletown, RI U.S.A.
Tel: +1 401 847 3327 Fax: +1 401 849 0045
E-mail: info@kvh.com

KVH Industries Pte Ltd.
Asia-Pacific Headquarters
Singapore
Tel: +65 6513 0290 Fax: +65 6472 3469
E-mail: info@apac.kvh.com