



# TracVision M5/M7 Switchplate Configuration



**TracVision M5/M7 User's Guide**

# TracVision M5/M7

## Switchplate Configuration

## User's Guide

This user's guide provides all of the basic information you need to operate, set up, and troubleshoot the TracVision M5/M7 satellite TV antenna system. For detailed installation information, please refer to the *TracVision M5/M7 Installation Guide*.



Please direct questions, comments, or suggestions to:

**KVH Industries, Inc.**

50 Enterprise Center  
 Middletown, RI 02842-5279 USA  
 Tel: +1 401 847-3327  
 Fax: +1 401 849-0045  
 E-mail: [info@kvh.com](mailto:info@kvh.com)  
 Internet: [www.kvh.com](http://www.kvh.com)

**KVH Europe A/S**

Kokkedal Industripark 2B  
 2980 Kokkedal, Denmark  
 Tel: +45 45 160 180  
 Fax: +45 45 160 181  
 E-mail: [info@kvh.dk](mailto:info@kvh.dk)  
 Internet: [www.kvh.com](http://www.kvh.com)

**If you have any comments regarding this manual, please e-mail them to [manuals@kvh.com](mailto:manuals@kvh.com). Your input is greatly appreciated!**



KVH Part # 54-0419 Rev. A  
 © 2007, KVH Industries, Inc., All rights reserved.  
 U.S. Patents Pending



TracVision and KVH are registered trademarks of KVH Industries, Inc.

The unique light-colored dome with dark contrasting base is a registered trademark of KVH Industries, Inc.

DVB (Digital Video Broadcasting) is a registered trademark of the DVB Project.

DIRECTV is an official trademark of DIRECTV, Inc.

DISH Network is an official trademark of EchoStar Communications Corporation.

ExpressVu is a property of Bell ExpressVu, a wholly owned subsidiary of Bell Satellite Services.

All other trademarks are the property of their respective owners.



# Table of Contents

<b>1</b>	<b>Introduction</b>	
	Using this Manual .....	3
	System Overview .....	5
	Circular and Linear Versions.....	7
<b>2</b>	<b>Operation</b>	
	Receiving Satellite TV Signals .....	11
	Turning the System On/Off .....	12
	Changing Channels and Switching Between Satellites .....	13
	Product Care .....	16
<b>3</b>	<b>Settings</b>	
	Connecting a PC to the Maintenance Port .....	19
	Setting Sleep Mode .....	21
	Setting Latitude and Longitude.....	22
	Programming the Antenna to Track Different Satellites .....	23
	Setting the LNB Skew Angle (Linear Version Only).....	26
<b>4</b>	<b>Troubleshooting</b>	
	Five Simple Checks .....	33
	Troubleshooting Matrix.....	34
	Causes and Remedies for Operational Issues .....	35
	Technical Support.....	39
	Field Replaceable Units .....	40

<b>A</b>	<b>TracVision M5 Wiring Diagrams</b>	
	TracVision M5 Wiring Diagram for One or Two Receivers .....	45
	TracVision M5 Wiring Diagram for Three or Four Receivers (Circular Version Only) .....	46
<b>B</b>	<b>TracVision M7 Wiring Diagrams</b>	
	TracVision M7 Wiring Diagram for One or Two Receivers .....	49
	TracVision M7 Wiring Diagram for Three or Four Receivers (Circular Version Only) .....	50
	TracVision M7 Wiring Diagram for Three or Four Receivers (Linear Quad-output Version Only) .....	51
<b>C</b>	<b>Optional PC Functions</b>	
	Connecting a PC to the Maintenance Port .....	55
	Programming Your User-defined Satellite(s) .....	57
	Using a PC to Switch Between Satellites .....	62
<b>D</b>	<b>Position Grids</b>	
	European Position Grid.....	65
	North American Position Grid.....	66



# 1. Introduction

This chapter provides a basic overview of this manual and your TracVision system.

## Contents

- Using this Manual ..... 3
- System Overview ..... 5
- Circular and Linear Versions..... 7





## Using this Manual

This manual provides complete operation, setup, and troubleshooting information for your TracVision system, as well as wiring diagrams for various TracVision M5/M7 configurations.

### Who Should Use This Manual

The **user** should refer to the "Operation" chapter to learn how to operate the system.

The **user**, **installer**, or **servicing technician** should refer to the "Settings" chapter for information on configuring the system and the "Wiring Diagrams" appendices for information on connecting additional receivers.

The **user** and/or **servicing technician** should refer to the "Troubleshooting" chapter to help identify the cause of a system problem.

### Notifications Used in this Manual

This manual uses the following notifications to call attention to important information:



#### **CAUTION**

This is a danger, warning, or caution notice. Be sure to read these carefully to avoid injury!

#### ***IMPORTANT!***

This is an important notice. Be sure to read these carefully to ensure proper operation and configuration of your TracVision system.

**NOTE:** *This is a Note. Notes contain useful information about system settings.*

**TIP:** *This is a Tip. These contain helpful information, allowing you to get the most out of your TracVision system.*

## Typographical Conventions

This manual uses the following typographical conventions:

Text Example	Description
<b>HALT</b>	Bold text in capital letters indicates a command to be entered via a PC
<b>X</b>	Bold text in <i>italicized</i> capital letters indicates a variable portion of a command to be entered via a PC
<i>"Turning the System On/Off" on page 12.</i>	Cross-reference to another chapter in the manual or to a website

## Related Documentation

In addition to this User's Guide, the following documents are provided with your TracVision system:

Document	Description
Installation Guide	Complete product installation instructions
Product Registration Form	Details on registering the product
Warranty Statement	Warranty terms and conditions
Contents List	List of every part supplied in the kit

## System Overview

Your TracVision M5/M7 is a state-of-the-art, actively stabilized antenna system that delivers live satellite TV to your vessel's audio/video entertainment system. A basic system is illustrated below. TracVision M5 receiver wiring diagrams are provided in *"Appendix A" on page 43*. TracVision M7 receiver wiring diagrams are provided in *"Appendix B" on page 47*.

Figure 1-1 TracVision System Diagram (Typical Installation)

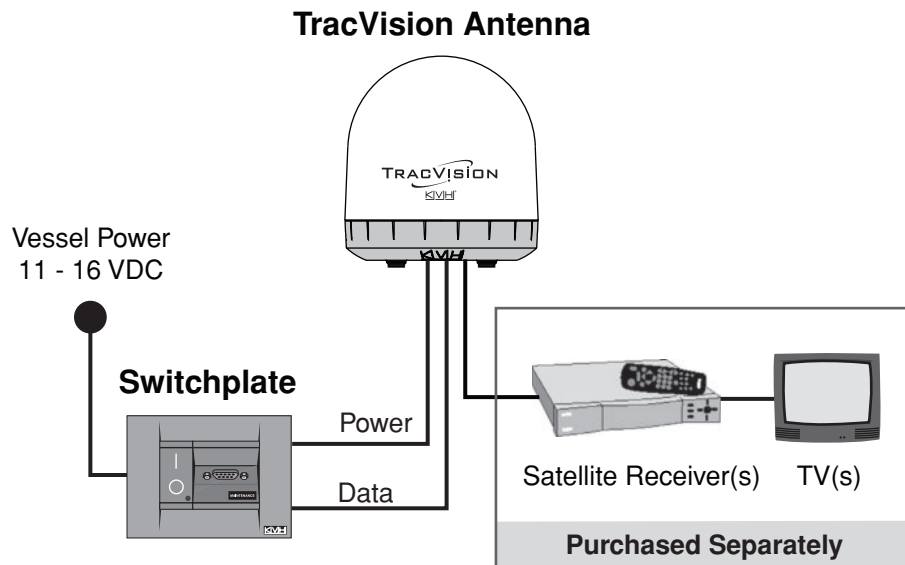

### Antenna Unit

The antenna unit houses the antenna positioning mechanism, LNB (low noise block), and control elements within a radome. Weathertight connectors join the power, signal, and control cabling from the belowdecks units.

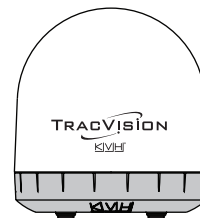

### Switchplate

The switchplate controls power to the antenna via the On/Off switch. The switchplate includes a maintenance port (DB9 connector), allowing the connection of a PC or an optional TV/SAT switch.



## System Features

Your TracVision M5/M7 system uses integrated DVB technology to quickly acquire and track the correct satellite, switch between your selected satellites, and send TV signals to the receiver.

### In-motion Tracking

The TracVision M5/M7 system uses a state-of-the-art actively stabilized antenna system. Once the satellite is acquired, the antenna's internal gyros continuously measure the heading, pitch, and roll of your vessel and send commands to the antenna motors, keeping the antenna pointed at the satellite at all times - even while you're on the move!

### Dual Satellite Tracking

Your TracVision M5/M7 is capable of tracking two selected satellites, as long as the antenna is located within the selected satellites' coverage area. During installation, your TracVision system should have been set up to track your desired pair of satellites, allowing you to switch between your selected pair of satellites quickly and easily.

### Satellite Library

The TracVision M5/M7 includes a pre-programmed satellite library of the most popular satellite services, offering a wide variety of satellite services to choose from. Using a PC, you can also add up to two additional satellites of your choice to the satellite library.

***TIP:** For complete information on the satellite library, see "[Programming the Antenna to Track Different Satellites](#)" on page 24. For complete information on adding satellites to the library, see "[Appendix C](#)" on page 53.*

## Circular and Linear Versions

Your TracVision system is configured for either circularly polarized satellite signals (North America) or linearly polarized satellite signals (Europe or Latin America). *Figure 1-2* illustrates the difference between these two polarizations.

Figure 1-2 Polarizations of Satellite Signals

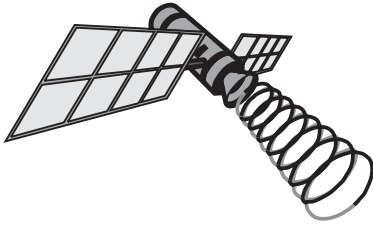
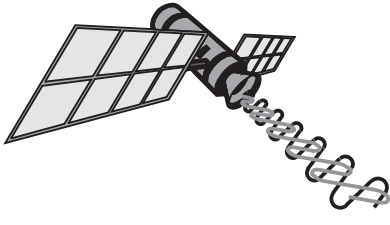
Circular	Linear
	
<p>Signals transmitted in two "corkscrew" patterns, one running clockwise and one running counter-clockwise</p>	<p>Signals transmitted in vertical and horizontal "waves" offset exactly 90° from each other</p>

## LNB Skew Angle

Since linear satellite signals are oriented in a precise cross pattern, the TracVision antenna's receiving element, called an LNB (low-noise block) must be oriented in the same way to optimize reception. This orientation adjustment is referred to as the LNB's "skew angle."

*Figure 1-3* illustrates how skew determines the amount of signal the LNB collects. The more signal, the better the reception.

Figure 1-3 How Skew Works

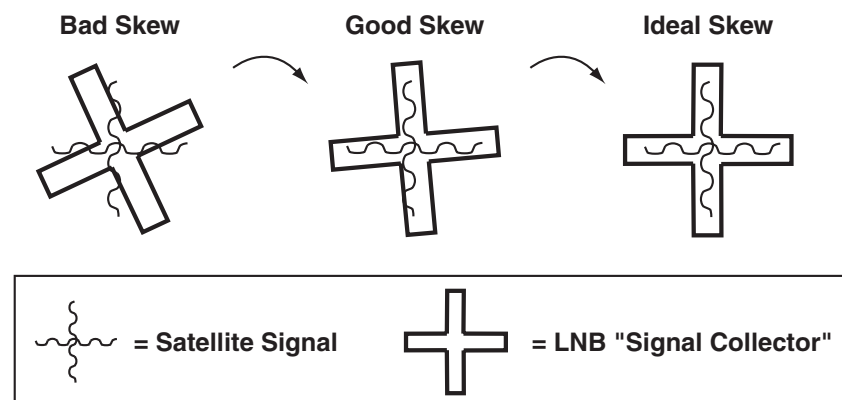

The correct skew setting varies depending on your geographic location, since the orientation of your antenna to the satellite changes as you move. For example, as shown in the figure below, if your antenna is tracking the PAS 9 satellite for Sky Mexico programming, the ideal skew setting ranges from +30 to +70, depending upon your location within the satellite's coverage area.

**Figure 1-4 Approximate Skew Settings for the PAS 9 Satellite**

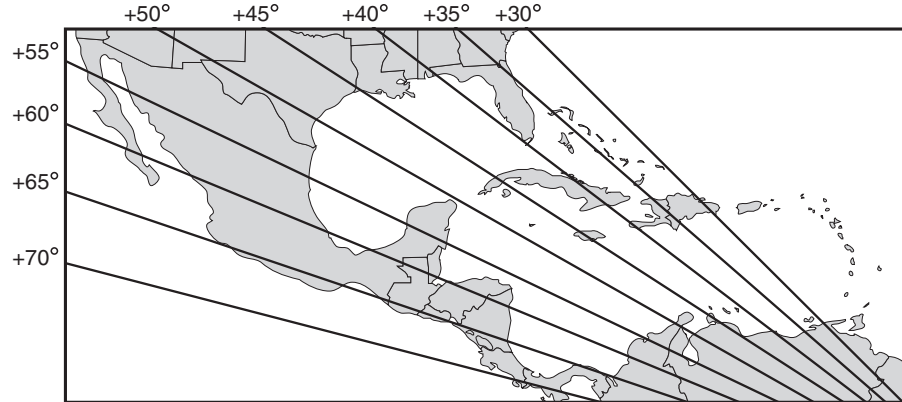

For complete details about adjusting the LNB's skew, see ["Setting the LNB Skew Angle \(Linear Systems Only\)"](#) on page 27.



# 2. Operation

This chapter explains everything you need to know to operate the TracVision system.

## Contents

Receiving Satellite TV Signals .....	11
Turning the System On/Off .....	12
Changing Channels and Switching Between Satellites.....	13
Product Care.....	16



## Receiving Satellite TV Signals

Television satellites are located in fixed positions above the Earth's equator and beam TV signals down to certain regions of the planet (not worldwide). To receive TV signals from a satellite, you must be located within that satellite's unique coverage area.

***TIP:** For your convenience, KVH provides links to several websites that offer satellite coverage information. Simply visit our website at [www.kvh.com/footprint](http://www.kvh.com/footprint).*

Figure 2-1 Location and Coverage Area of DIRECTV 101 Satellite

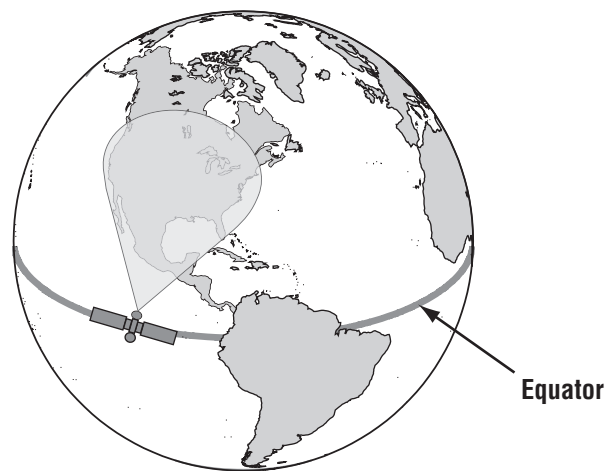

In addition, since TV satellites are located above the equator, the TracVision antenna must have a clear view of the sky to receive satellite TV signals. Anything that stands between the antenna and the satellite can block the signal, resulting in lost reception. Common causes of blockage include boat masts, trees, buildings, and bridges. Heavy rain, ice, or snow might also temporarily interrupt satellite signals.

Figure 2-2 Example of Satellite Blockage

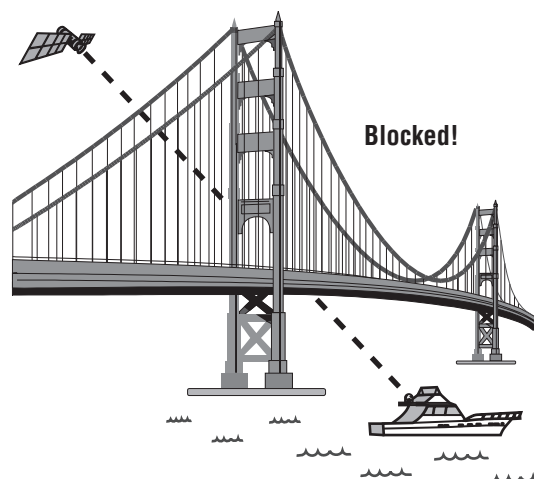

## Turning the System On/Off

Since power to the TracVision system is controlled by the switchplate, you can turn the system on or off using the switchplate.

### Turning On the System

Follow the steps below to turn on your TracVision system.

1. Make sure the antenna has a clear view of the sky.
2. Turn on your satellite TV receiver and TV.

**IMPORTANT!**

Avoid turning the vessel or changing channels for one minute after turning on the system.

3. Set the switchplate's Power switch to the ON (up) position.

Figure 2-3 Switchplate Power Switch

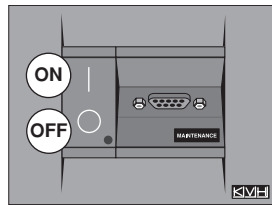

4. Wait one minute for system startup.

### Turning Off the System

Follow the steps below to turn off your TracVision system.

1. Set the switchplate's Power switch to the OFF (down) position.
2. Turn off your satellite TV receiver and TV.

## Changing Channels and Switching Between Satellites

During installation, your TracVision system should have been set up to track the satellite(s) of your choice and the channel guides for your selected satellite service should have been downloaded. Your TracVision system is programmed to track up to two satellites, stored in memory as Satellite A and Satellite B.

### **IMPORTANT!**

**(Linear systems only)** To ensure proper operation, the receiver(s) must be set up for the same satellites, and in the same order, they are set up in the antenna:

Antenna Satellite	Receiver Satellite	DiSEqC Setting
Sat. A	Alternative 1 or A	DiSEqC 1
Sat. B	Alternative 2 or B	DiSEqC 2

Since some channels might be located on another satellite, changing channels might require switching to the second selected satellite. Most TracVision M5/M7 configurations allow automatic switching between the selected satellites by simply using the primary receiver's remote control. However, some TracVision M5/M7 configurations require using an optional TV/SAT Switch or a PC. Refer to the appendices for more information on configuration requirements.

***NOTE:** At this time, DISH Network supports only the standard-definition model 311 receiver for mobile use. All other receiver models have been designated for home use only. DISH Network subscribers must use the optional TV/SAT Switch (KVH Part # 01-0245) to change satellites.*

***TIP:** The primary receiver is the receiver connected to the antenna's RF1 connector. The primary receiver controls satellite selection; all other receivers can only receive channels carried on the satellite selected by the primary receiver.*

### Using the Receiver Remote Control to Switch Between Satellites

With most TracVision M5/M7 configurations, switching between the selected satellites occurs automatically while changing channels using the primary receiver's remote control.

***NOTE:** Be sure to use a single-input receiver as the primary receiver.*

## Using the TV/SAT Switch to Switch Between Satellites - Optional

Switching between your selected satellites using the optional TV/SAT Switch (KVH Part # 01-0245) is as easy as pressing a single button.

Figure 2-4 TV/SAT Switch

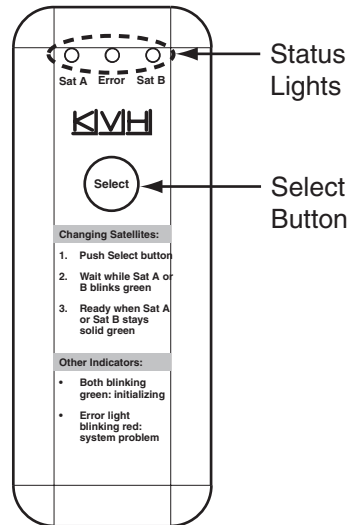

The Select button is used for all operator controls. The TV/SAT Switch also has three status lights that show its current status. [Figure 2-5](#) explains the function of each indicator.

Figure 2-5 Status Light Functions

Light	Status	Meaning
Sat A	Blinking green	Wait - searching for satellite
	Solid green	Tracking Satellite A
Error	Blinking red	System problem - refer to <i>"Troubleshooting" on page 33.</i>
Sat B	Blinking green	Wait - searching for satellite
	Solid green	Tracking Satellite B

## Connect the TV/SAT Switch

To use the TV/SAT Switch, you must first connect it to the maintenance port on the switchplate.

### **IMPORTANT!**

To ensure proper operation, be sure to turn off the TracVision system before connecting the TV/SAT Switch.

1. Set the switchplate's power switch to the Off position.
2. Connect the TV/SAT Switch's data cable to the maintenance port (DB9 connector) located on the switchplate.

Figure 2-6 Switchplate DB9 Connector

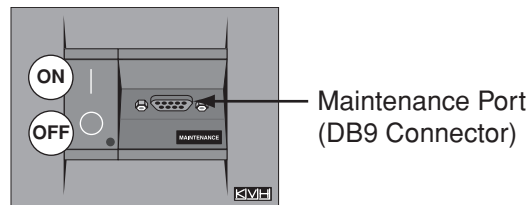

3. Set the switchplate's power switch to the On (up) position. Wait one minute for the system to initialize.

*NOTE: The Sat A and Sat B status lights on the TV/SAT Switch blink while the system initializes.*

4. Either the Sat A or Sat B status light will turn solid green - depending on which satellite is currently being tracked (see [Figure 2-5 on page 14](#)).

## Switching Between Satellites

Perform the following steps to switch to the second satellite:

1. Press the Select button on the TV/SAT Switch.
2. The status light for the currently tracked satellite (Sat A or Sat B) extinguishes, while the status light for the second satellite begins blinking.
3. Once the status light for the second satellite turns solid green, the TracVision system has begun tracking the second satellite. You can now use your receiver remote control to change channels on the new satellite.

## Product Care

Please consider the following antenna care guidelines for maintaining peak performance:

- Periodically wash the exterior of the antenna dome with fresh water and mild detergent. Avoid harsh cleansers and volatile solvents (such as acetone) and do not spray the dome directly with high-pressure water.
- If you wish to paint the dome, use only non-metallic automotive paint without a primer coat. Any paint that contains metal will block satellite signals and impair reception.



# 3. Settings

This chapter contains information on system settings and how to modify them.

## Contents

Connecting a PC to the Maintenance Port.....	19
Setting Sleep Mode .....	21
Setting Latitude and Longitude .....	22
Programming the Antenna to Track Different Satellites.....	23
Setting the LNB Skew Angle (Linear Version Only).....	26



## Connecting a PC to the Maintenance Port

In order to modify system settings, you first need to connect a PC to the TracVision M5/M7 system. The section explains how to connect a PC to the TracVision system. This procedure requires a PC with Windows HyperTerminal and a straight serial data cable.

**TIP:** If you are a KVH-authorized technician, you can use the KVH Flash Update Wizard instead of HyperTerminal. Enter commands in the wizard's "Antenna Comms" window. You do not need to flash the antenna to enter commands.

1. Set the switchplate's power switch to the Off (down) position.

Figure 3-1 Switchplate Power Switch and Maintenance Port

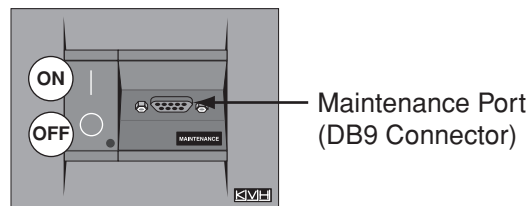

2. Connect one end of a straight serial data cable to the maintenance port (DB9 connector) located on the switchplate. Connect the other end of the data cable to the serial port on you PC.

**TIP:** If your computer does not have a DB9 serial COM port, you can use the following USB-to-RS232 adapters: IO Gear Part # GUC232A (visit [www.iogear.com](http://www.iogear.com)) or Belkin Part # F5U109 (visit [www.belkin.com](http://www.belkin.com)).

3. Open HyperTerminal and establish the following settings:
  - Bits per second: 9600
  - Data bits: 8
  - Parity: None
  - Stop Bits: 1
  - Flow Control: None

Figure 3-2 HyperTerminal Settings

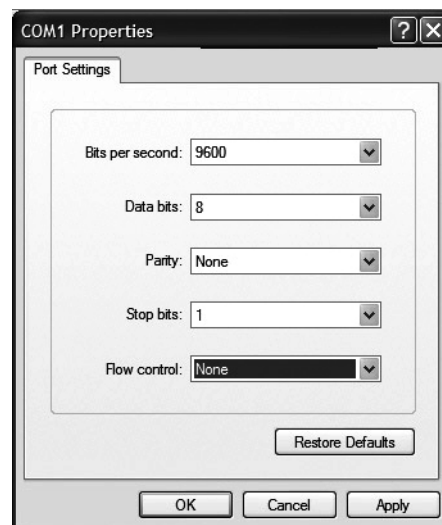

***TIP:** To view characters on the screen as you type, set up HyperTerminal to echo typed characters. Select "Properties" from the File menu; select "ASCII Setup" at the Settings tab; then select "Echo typed characters locally" at the ASCII Setup window.*

4. Set the switchplate's power switch to the On (up) position. Wait one minute for the system to initialize.

## Setting Sleep Mode

When the vessel has come to a stop and holds its position for one minute (e.g., at a dock), the antenna unit enters Sleep Mode, which locks the antenna in place to conserve power. As soon as the vessel moves beyond a 1° - 2° window or the signal level changes significantly, Sleep Mode automatically turns off and the system begins tracking the satellite again (or enters Search Mode to find the satellite).

KVH recognizes that some customers might not want to take advantage of this convenient feature. In this case, it is possible to disable Sleep Mode.

Follow the instructions below if you wish to disable Sleep Mode, or if you wish to restore the original Sleep Mode setting.

1. Connect a PC to the maintenance port, as described in *["Connecting a PC to the Maintenance Port" on page 19.](#)* Then type the following commands in the HyperTerminal window.
2. Type **HALT** then press Enter.
3. Type **DEBUGON** then press Enter.
- 4a. To disable Sleep Mode:  
Type **SLEEPOFF** then press Enter.
- 4b. To enable Sleep Mode:  
Type **SLEEPON** then press Enter.
5. Type **ZAP** then press Enter to restart the antenna. Wait one minute for the antenna to initialize.

## Setting Latitude and Longitude

Follow the instructions below if you wish to set your latitude and longitude data.

*TIP: For your convenience, you can determine your approximate latitude and longitude using the Position Grids provided in ["Appendix D" on page 63](#).*

1. Connect a PC to the maintenance port, as described in ["Connecting a PC to the Maintenance Port" on page 19](#). Then type the following commands in the HyperTerminal window.
2. Type **HALT** then press Enter.
3. Type the following **GPS** command then press Enter.

### **GPS,XX,D,YYY,Z**

Field	Description
XX	Your latitude (0-90)
D	S (South) or N (North)
YYY	Your longitude (0-180)
Z	E (East) or W (West)

4. Type **ZAP** then press Enter to restart the antenna. Wait one minute for the antenna to initialize.

## Programming the Antenna to Track Different Satellites

You can change which satellites your TracVision M5/M7 system tracks by choosing up to two satellites from the appropriate satellite library (your TracVision M5/M7 system is configured for either circular satellite reception or linear satellite reception). This procedure requires a PC with Windows HyperTerminal and a straight serial data cable.

***NOTE:** If the satellite you wish to track is not listed, you can set up one or two special user-defined satellites. See “Appendix C” on page 53 for details.*

***TIP:** Be sure to only install satellites that your TracVision M5/M7 can track in your geographic location. For your convenience, KVH provides links to several websites that offer satellite coverage information. Simply visit our website at [www.kvh.com/footprint](http://www.kvh.com/footprint).*

**Figure 3-3 Circular Satellite Library**

Satellite Service	Satellite Location	Installation Name
AsiaSat 4	122.2° E	ASIASAT*
DIRECTV	72.0° W	DSS_72
	101.0° W	DSS_101
	110.0° W	DSS_110*
	119.0° W	DSS_119
DIRECTV Latin America	95.0° W	GALAXY3CN*
DISH Network	61.5° W	ECHO_61
	110.0° W	ECHO_110
	119.0° W	ECHO_119
	148.0° W	ECHO_148
ExpressVu	82.0° W	EXPRESSVU
	91.0° W	EXPRESSTV

*\*NOTE: Reception of these satellites requires additional hardware. Please contact your local KVH-authorized dealer or KVH Technical Support for details.*

Figure 3-4 Linear Satellite Library

Satellite Location	Installation Name
26.0° E	ARABSAT
19.2° E	ASTRA1
28.2° E	ASTRA2N
28.2° E	ASTRA2S
7.0° E	EUTEL_W3A
30.0° W	HISPASAT
13.0° E	HOTBIRD
13.0° E	HOTBIRDWB
7.0° W	NILESAT
160.0° E	OPTUSB1*
156.0° E	OPTUSC1
58.0°W	PAS_9
110.5° E	SINOSAT*
5.0° E	SIRIUS
0.8° W	THOR
42.0° E	TURKSAT1C

*\*NOTE: Reception of these satellites requires additional hardware. Please contact your local KVH-authorized dealer or KVH Technical Support for details.*

**IMPORTANT!**

**Linear Systems Only** - For optimal performance, you might need to adjust the skew angle if you change satellites. For information on setting the skew angle, see "[Setting the LNB Skew Angle \(Linear Version Only\)](#)" on page 26.

## Program the New Satellites to be Tracked

1. Connect a PC to the maintenance port, as described in *"Connecting a PC to the Maintenance Port" on page 19*. Then type the following commands in the HyperTerminal window.
2. Type **HALT** then press Enter.
3. Type the following **SATINSTALL** command then press Enter.

### **SATINSTALL,X,Y**

Field	Description
X	The installation name of your choice for Satellite A
Y	The installation name of your choice for Satellite B

#### **IMPORTANT!**

**(Linear systems only)** To ensure proper operation, the receiver(s) must be set up for the same satellites, and in the same order, they are set up in the antenna:

Antenna Satellite	Receiver Satellite	DiSEqC Setting
Sat. A	Alternative 1 or A	DiSEqC 1
Sat. B	Alternative 2 or B	DiSEqC 2

4. Type **ZAP** then press Enter to restart the antenna. Wait one minute for the antenna to initialize.

#### **Example**

To select EUTELW3A (as your choice for Satellite A) and HOTBIRD (as your choice for Satellite B) for tracking, you would enter the following commands into the antenna via your HyperTerminal connection:

```
HALT
SATINSTALL,EUTEL_W3A,HOTBIRD
ZAP
```

## Setting the LNB Skew Angle (Linear Version Only)

To optimize satellite signal reception, you need to adjust antenna's LNB (low-noise block) skew angle whenever you change your geographic location or change which satellites are set up for tracking. Before setting the skew angle, be sure to determine the correct skew angle for your selected satellite(s).

*TIP: Sky Mexico subscribers can also refer to [Figure 1-4 on page 8](#) for approximate skew setting for the PAS\_9 satellite.*

### Determining the Skew Angle

Follow the steps below to determine the skew angle for the selected satellite(s).

1. Connect a PC to the maintenance port, as described in ["Connecting a PC to the Maintenance Port" on page 19](#). Then type the following commands in the HyperTerminal window.
2. Type **HALT** then press Enter.
3. Type **DEBUGON** then press Enter.
4. Determine your latitude and longitude.

*TIP: For your convenience, you can determine your approximate latitude and longitude using the Position Grids provided in ["Appendix D" on page 63](#).*

5. Type the following **GPS** command then press Enter.

**GPS,XX,D,YYY,Z**

Field	Description
XX	Your latitude (0-90)
D	S (South) or N (North)
YYY	Your longitude (0-180)
Z	E (East) or W (West)

6. Type **SKEWANGLE** then press Enter. The skew for the selected satellite is displayed. Write the skew value down for later use.
7. Skip to *"Adjusting the Skew Angle" on page 27.*

## Adjusting the Skew Angle

Once you have determined the proper skew angle, follow the steps below to adjust the antenna's LNB skew angle.



### CAUTION

To avoid bodily injury, be sure to turn off the antenna and disconnect power to all wired components.

1. Turn off the antenna and disconnect power to all wired components.
2. Using a Phillips-head screwdriver, remove the screws securing the radome. Then remove the radome and set it aside in a safe place.
3. Locate the LNB assembly on the back of the antenna reflector.

Figure 3-5 Location of LNB on Back of Antenna Reflector

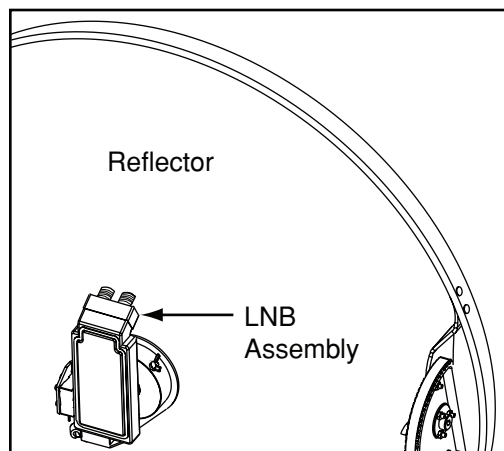

4. Loosen the two choke feed wing screws. The location of the wing screws varies according to TracVision model. Refer to [Figure 3-6](#) and [Figure 3-7](#).

Figure 3-6 TracVision M5 Wing Screws

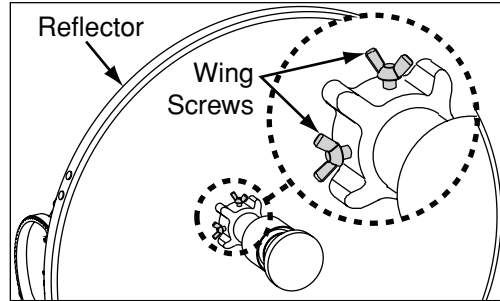
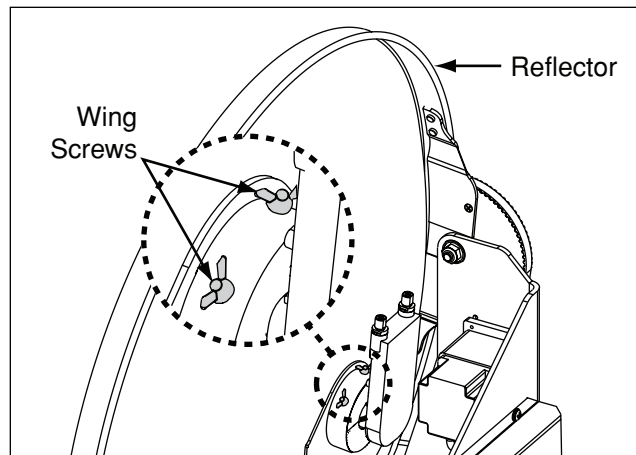

Figure 3-7 TracVision M7 Wing Screws



- 5a. **TracVision M5 Only** - Adjust the LNB clockwise or counter-clockwise, until the skew arrow on the LNB points to the skew angle that you determined earlier. If the skew angle is greater than +15° subtract 180 to get the equivalent negative skew angle and set the LNB to that angle instead.

**IMPORTANT!**

Be sure to keep the LNB fully inserted into the choke feed to ensure optimum performance.

Figure 3-8 TracVision M5 LNB Skew Angle Adjustment

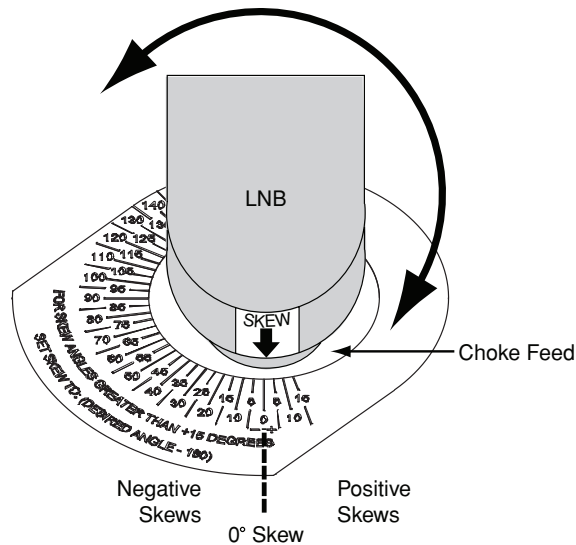

- 5b. **TracVision M7 Only** - Adjust the LNB clockwise or counter-clockwise, until the skew arrow on the LNB points to the skew angle that you determined earlier.

**IMPORTANT!**

Be sure to keep the LNB fully inserted into the choke feed to ensure optimum performance.

Figure 3-9 TracVision M7 LNB Skew Angle Adjustment

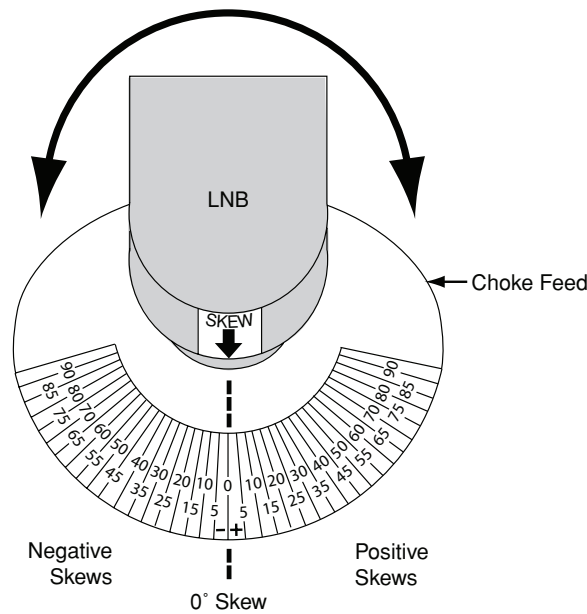

6. Tighten the wing screws.
7. Reinstall the radome.

**NOTE:** For more information about how skew works, see [“Circular and Linear Versions”](#) on page 7.



# 4. Troubleshooting

This chapter identifies potential basic problems along with their possible causes and solutions. It also explains how to get technical support.

## Contents

- Five Simple Checks ..... 33
- Troubleshooting Matrix..... 34
- Causes and Remedies for Operational Issues ..... 35
- Technical Support..... 39
- Field Replaceable Units ..... 40





## Five Simple Checks

If you are experiencing a problem receiving satellite TV with your TracVision system, perform the five simple checks below.

*TIP: You can also try resetting the satellite TV receiver. Turn off and unplug the receiver, wait one minute, then plug it back in and turn it back on.*

### Can the antenna see the satellite?

The antenna requires an unobstructed view of the sky to receive satellite TV signals. Common causes of blockage include trees, buildings, bridges, and mountains.

### Is there excessive dirt or moisture on the antenna dome?

Dirt buildup or moisture on the dome can reduce satellite reception. Clean the exterior of the dome periodically.

### Is it raining heavily?

Heavy rain or snow can weaken satellite TV signals. Reception should improve once the inclement weather subsides.

### Is everything turned on and connected properly?

Make sure your TV and receiver are both turned on and set up for the satellite input. Finally, check any connecting cables to ensure none have come loose.

### Is the antenna's LNB set to the correct skew angle? (Linear Systems Only)

To optimize reception, the antenna's LNB needs to be set to the correct skew angle for the satellite(s) you want to track. See "[Setting the LNB Skew Angle \(Linear Version Only\)](#)" on page 26 for details.

# Troubleshooting Matrix

The troubleshooting matrix identifies potential operational symptoms and their causes and remedies. *“Causes and Remedies for Operational Issues” on page 35* contains detailed information on the causes and remedies listed below.

Figure 4-1 Troubleshooting Matrix

SYMPTOM	CAUSES AND REMEDIES										
	Receiver fault or improper receiver configuration	Satellite coverage issue	Satellite signal blocked	Radar interference	Satellite frequency	Vessel turning frequency data changed	Insufficient power	Improper wiring	Loose RF connectors	Type of multiswitch used	Cable unwrap
Antenna non-functional							x	x			
Antenna not switching satellites	x	x	x				x	x	x	x	
No picture on TV set	x	x	x	x	x				x	x	
Certain channels do not work	x	x	x		x		x	x	x		
Intermittent picture for short intervals		x	x	x		x			x	x	x
System works at dock but not on the move			x								
System will not find satellite	x	x	x	x	x	x	x	x	x	x	
Snowy television picture	x						x	x	x		
Pixelating television picture	x		x	x			x	x	x		

## Causes and Remedies for Operational Issues

This section addresses the most common operational issues that can affect the performance of the TracVision M5/M7. If your TracVision system requires service, you can visit any KVH-authorized dealer or distributor for assistance. To find a KVH-authorized dealer near you, visit [www.kvh.com/wheretogetservice](http://www.kvh.com/wheretogetservice).

### Receiver Fault or Improper Receiver Configuration

#### Receiver Fault

Your satellite TV receiver might be set up incorrectly or defective. First check the receiver's configuration to ensure it is set up for the desired programming. In the case of a faulty receiver, refer to your selected receiver's user manual for service and warranty information.

#### Improper Receiver Configuration (Linear Systems Only)

To ensure proper operation, the receiver(s) must be set up for the same satellites, and in the same order, they are set up in the antenna:

Antenna Satellite	Receiver Satellite	DiSEqC Setting
Sat. A	Alternative 1 or A	DiSEqC 1
Sat. B	Alternative 2 or B	DiSEqC 2

## Satellite Coverage Issue

Television satellites are located in fixed positions above the Earth's equator and beam TV signals down to certain regions of the planet (not worldwide). To receive TV signals from a satellite, you must be located within that satellite's unique coverage area.

*TIP: For your convenience, KVH provides links to several websites that offer satellite coverage information. Simply visit our website at [www.kvh.com/footprint](http://www.kvh.com/footprint).*

Figure 4-2 Location and Coverage Area of DIRECTV 101 Satellite

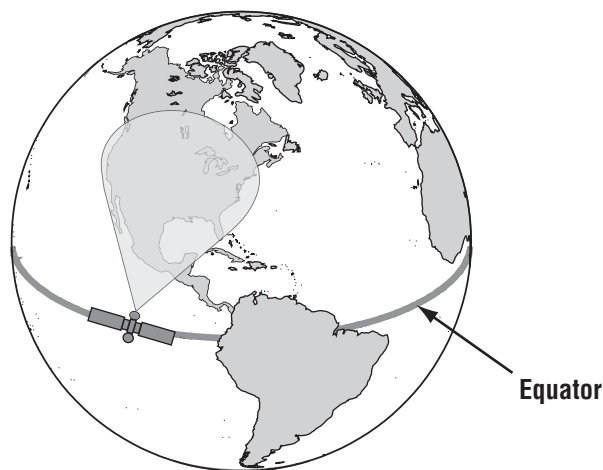

## Satellite Signal Blocked

Since TV satellites are located above the equator, the TracVision antenna must have a clear view of the sky to receive satellite TV signals. Anything that stands between the antenna and the satellite can block the signal, resulting in lost reception. Common causes of blockage include boat masts, trees, buildings, and bridges. Heavy rain, ice, or snow might also temporarily interrupt satellite signals.

Figure 4-3 Example of Satellite Blockage

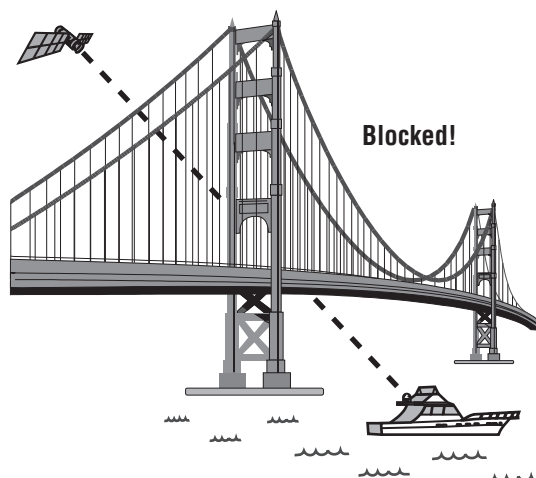

## Radar Interference

The TracVision M5/M7 antenna must be kept out of line with nearby radars, as their energy levels might overload the antenna's front-end circuits. Refer to the *TracVision M5/M7 Installation Guide* for details or visit any KVH-authorized dealer or distributor for assistance. To find a KVH-authorized dealer near you, visit [www.kvh.com/wheretogetservice](http://www.kvh.com/wheretogetservice).

## Satellite Frequency Data Changed

If some channels work, while one or more other channels do not, or if the antenna cannot find the selected satellite, the satellite's frequency data might have changed. You can visit any KVH-authorized dealer or distributor for assistance. To find a KVH-authorized dealer near you, visit [www.kvh.com/wheretogetservice](http://www.kvh.com/wheretogetservice).

## Vessel Turning During Startup

If the vessel turns during the first minute after startup, the gyro calibration that occurs during startup might be faulty. This might cause the TracVision M5/M7 to track improperly. To solve this problem, simply turn off the TracVision M5/M7 system for at least ten seconds. Then turn on the TracVision system, ensuring the vessel is either motionless or traveling in a straight line for the first minute after startup.

## Insufficient Power

If the power cable to the antenna unit is more than 50 ft (15 m) long, the power level can decrease over the course of the cable, resulting in a voltage level at the antenna that is too low to power the system. Refer to the *TracVision M5/M7 Installation Guide* for details on supplying adequate power to the antenna or visit any KVH-authorized dealer or distributor for assistance. To find a KVH-authorized dealer near you, visit [www.kvh.com/wheretogetservice](http://www.kvh.com/wheretogetservice).

## Improper Wiring

If the system has been improperly wired, the antenna will not operate correctly. Refer to the *TracVision M5/M7 Installation Guide* for complete system wiring information or visit any KVH-authorized dealer or distributor for assistance. To find a KVH-authorized dealer near you, visit [www.kvh.com/wheretogetservice](http://www.kvh.com/wheretogetservice).

## Loose RF Connectors

KVH recommends periodically checking the system's cable connections. A loose RF connector can reduce signal quality or prevent automatic satellite switching using the receiver's remote control. Refer to the *TracVision M5/M7 Installation Guide* for complete system wiring information or visit any KVH-authorized dealer or distributor for assistance. To find a KVH-authorized dealer near you, visit [www.kvh.com/wheretogetservice](http://www.kvh.com/wheretogetservice).

## Type of Multiswitch Used

If your TracVision system's configuration requires a multiswitch, an active (powered) multiswitch must be used to ensure proper antenna performance. Refer to the Wiring Diagrams in "[Appendix A](#)" on [page 43](#) or "[Appendix B](#)" on [page 47](#) for detailed information.

## Cable Unwrap

If your vessel makes several consecutive circles in the same direction, the antenna will rotate 720° before reaching the end of its internal cable. If this occurs, the system will automatically unwrap the cable by quickly rotating the antenna dish in the opposite direction. During this time, your TV picture will freeze momentarily.

## Technical Support

The TracVision M5/M7 antenna is a sophisticated electronic device; only KVH-authorized technicians have the specialized tools and expertise necessary to diagnose and repair a system fault. Therefore, if you experience any operating problem or require technical assistance, please call or visit your local authorized TracVision dealer or distributor. To find a KVH-authorized dealer near you, visit [www.kvh.com/wheretogetservice](http://www.kvh.com/wheretogetservice).

If you need help finding an authorized technician, please contact KVH Technical Support:

**North American, South America, Australia, New Zealand:**

Phone: +1 401 847-3327

E-mail: [techs@kvh.com](mailto:techs@kvh.com)

**Europe, Middle East, Asia:**

Phone: +45 45 160 180

E-mail: [support@kvh.dk](mailto:support@kvh.dk)

Please have your antenna serial number handy before you call. You can get this serial number from the sticker located on the first page of this manual.

## Field Replaceable Units

If you experience any operating problem or require technical assistance, please call or visit your local authorized TracVision dealer or distributor. To find a KVH-authorized dealer near you, visit [www.kvh.com/wheretogetservice](http://www.kvh.com/wheretogetservice).

Part numbers for field replaceable units (FRUs) that can be serviced in the field are listed in [Figure 4-4](#). These parts can be obtained from any KVH-authorized dealer or distributor.

Figure 4-4 Field Replaceable Units (continued on next page)

Part	Part Number
Radome (TracVision M5 Only)	02-0925-07 <sup>†</sup>
Radome (TracVision M7 Only)	02-1047-05 <sup>†</sup>
Switchplate	02-1023
Main PCB (printed circuit board)	72-0258
RF PCB (printed circuit board)	72-0259
Inverter PCB (printed circuit board)	72-0260
Gyro	72-0261
Elevation drive belt	72-0263
Elevation motor	72-0262
Azimuth limit switch (TracVision M7 Only)	72-0264

<sup>†</sup>Specify color when ordering

**Figure 4-4 Field Replaceable Units (continued)**

LNB - circular dual-output	72-0265
LNB - Galaxy circular dual-output	72-0266
LNB - linear dual-output	72-0267
LNB - linear quad-output (TracVision M7 Only)	72-0268
Feed tube	72-0269
Antenna data cable, 50 ft.	32-0619-50
Antenna data cable, 100 ft.	32-0619-100
RF flash cable, 15 ft.	32-0728
PC data cable, 6 ft.	32-0628-06
Antenna power cable, 100 ft.	32-0510-100
Ground cable, 50 ft.	32-0583-50



# Appendix A

# TracVision M5 Wiring Diagrams

This appendix provides receiver wiring diagrams for basic TracVision M5 configurations. Wiring diagrams vary according to the number of receivers installed and the TracVision system configuration (circular or linear). For installation instructions, refer to the *TracVision M5/M7 Installation Guide*.

## Contents

TracVision M5 Wiring Diagram for One or Two Receivers.....	45
TracVision M5 Wiring Diagram for Three or Four Receivers (Circular Version Only) .....	46



# TracVision M5 Wiring Diagram for One or Two Receivers

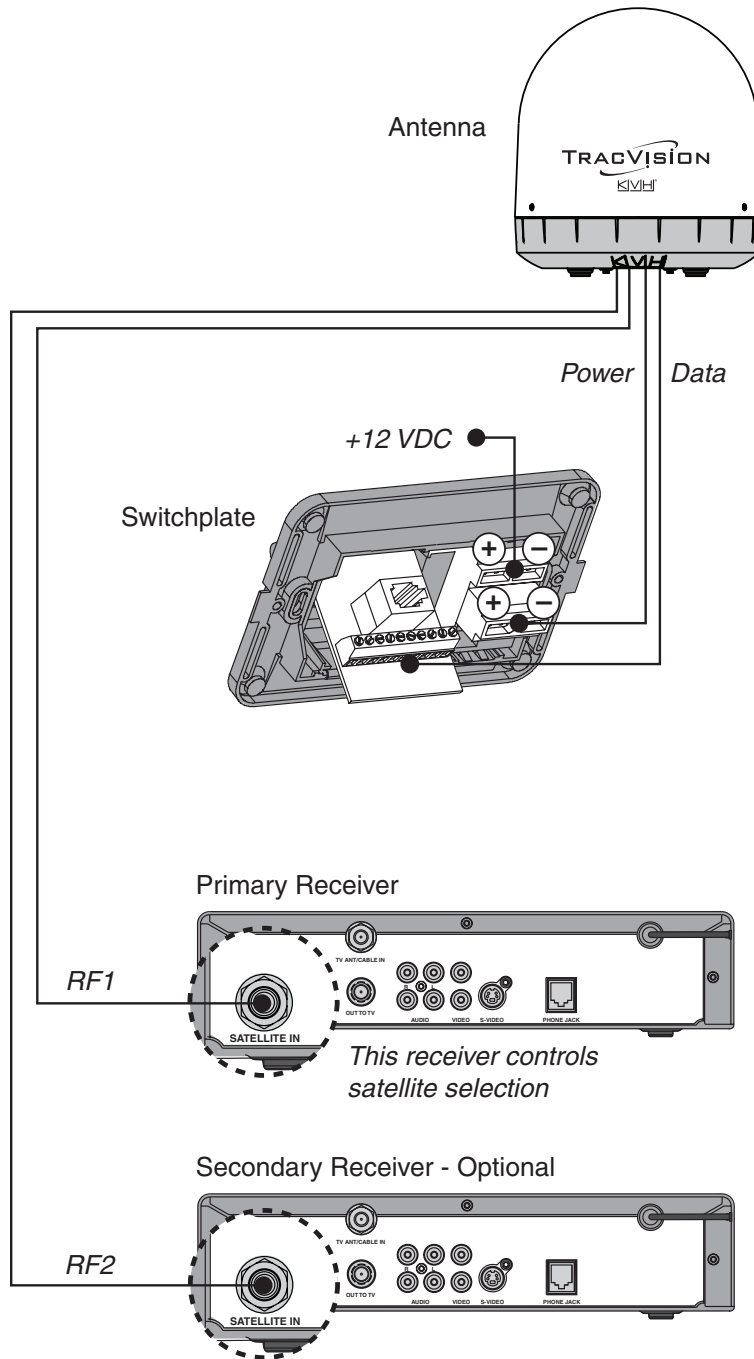

# TracVision M5 Wiring Diagram for Three or Four Receivers (Circular Version Only)\*

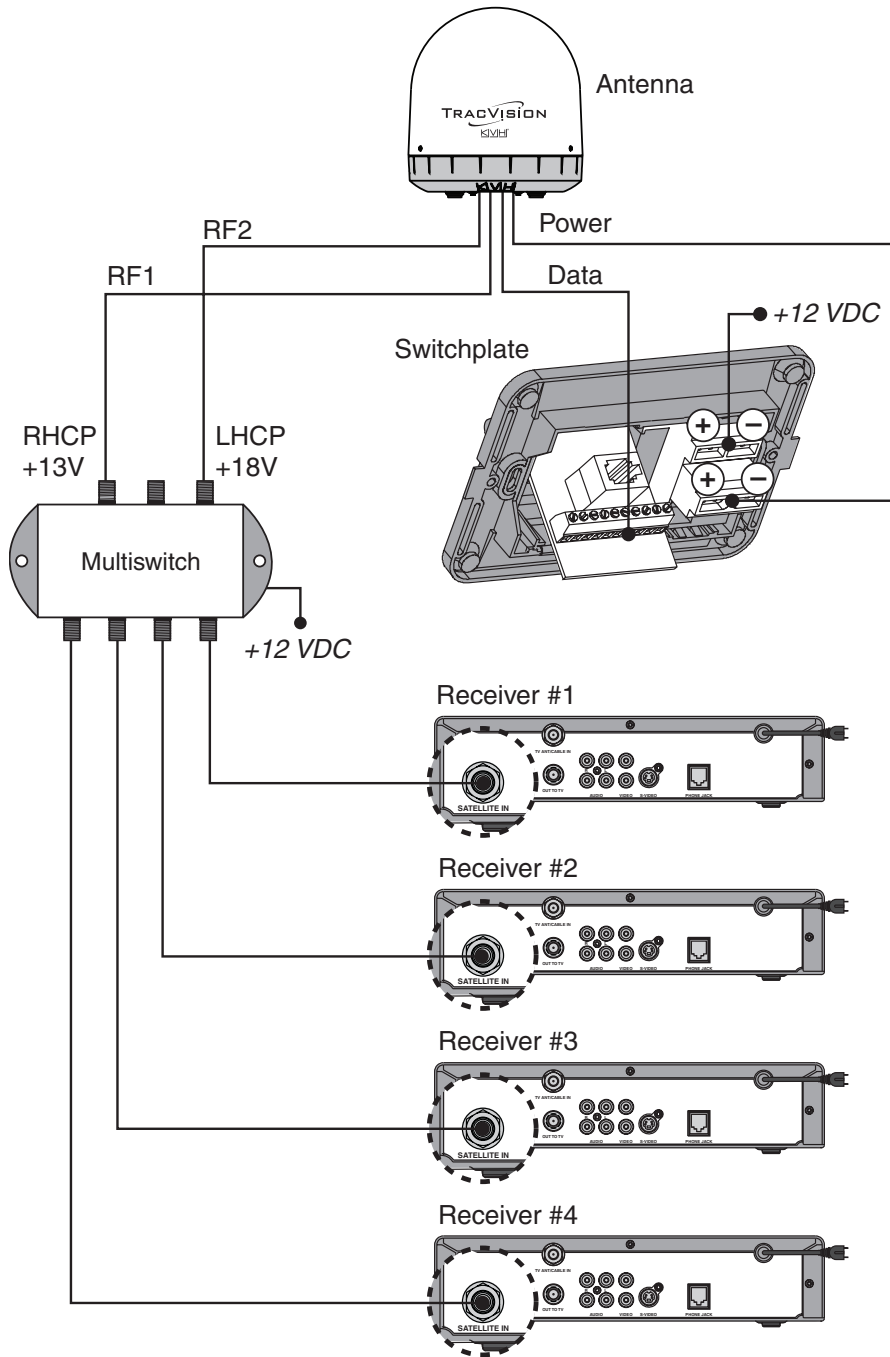

**\*NOTE:** This configuration requires an active (powered) multiswitch, such as Channel Master model 6314IFD. You can purchase this multiswitch from KVH (KVH P/N 19-0123). Be sure to terminate all unused output connectors with 75 ohm DC blocks (Channel Master model #7184 or equivalent). This configuration also requires the use of either a PC or an optional TV/SAT Switch (KVH P/N 01-0245) to switch between satellites.



# Appendix B

# TracVision M7 Wiring Diagrams

This appendix provides receiver wiring diagrams for basic TracVision M7 configurations. Wiring diagrams vary according to the number of receivers installed and the TracVision system configuration (circular/linear and dual/quad-output). For installation instructions, refer to the *TracVision M5/M7 Installation Guide*.

## Contents

TracVision M7 Wiring Diagram for One or Two Receivers.....	49
TracVision M7 Wiring Diagram for Three or Four Receivers (Circular Version Only) .....	50
TracVision M7 Wiring Diagram for Three or Four Receivers (Linear Quad-output Version Only).....	51



# TracVision M7 Wiring Diagram for One or Two Receivers

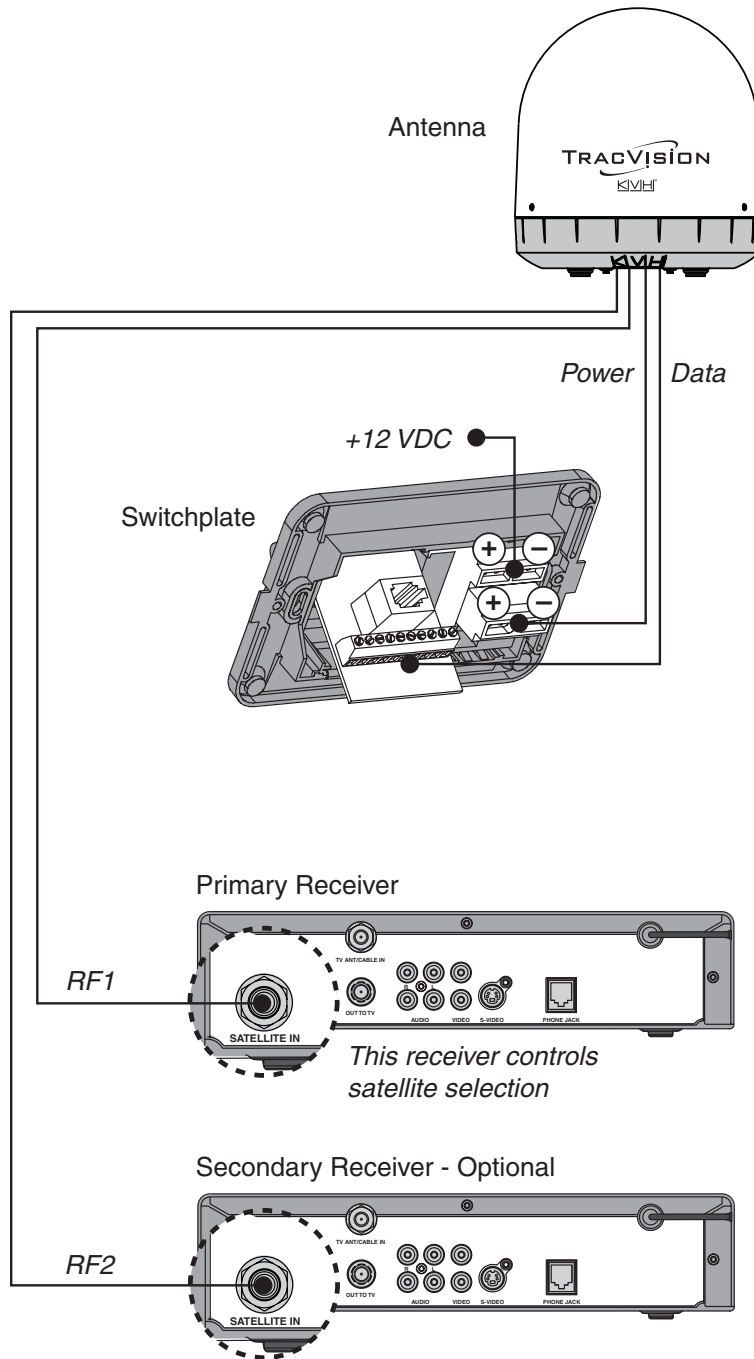

Circular Version Only

# TracVision M7 Wiring Diagram for Three or Four Receivers (Circular Version Only)\*

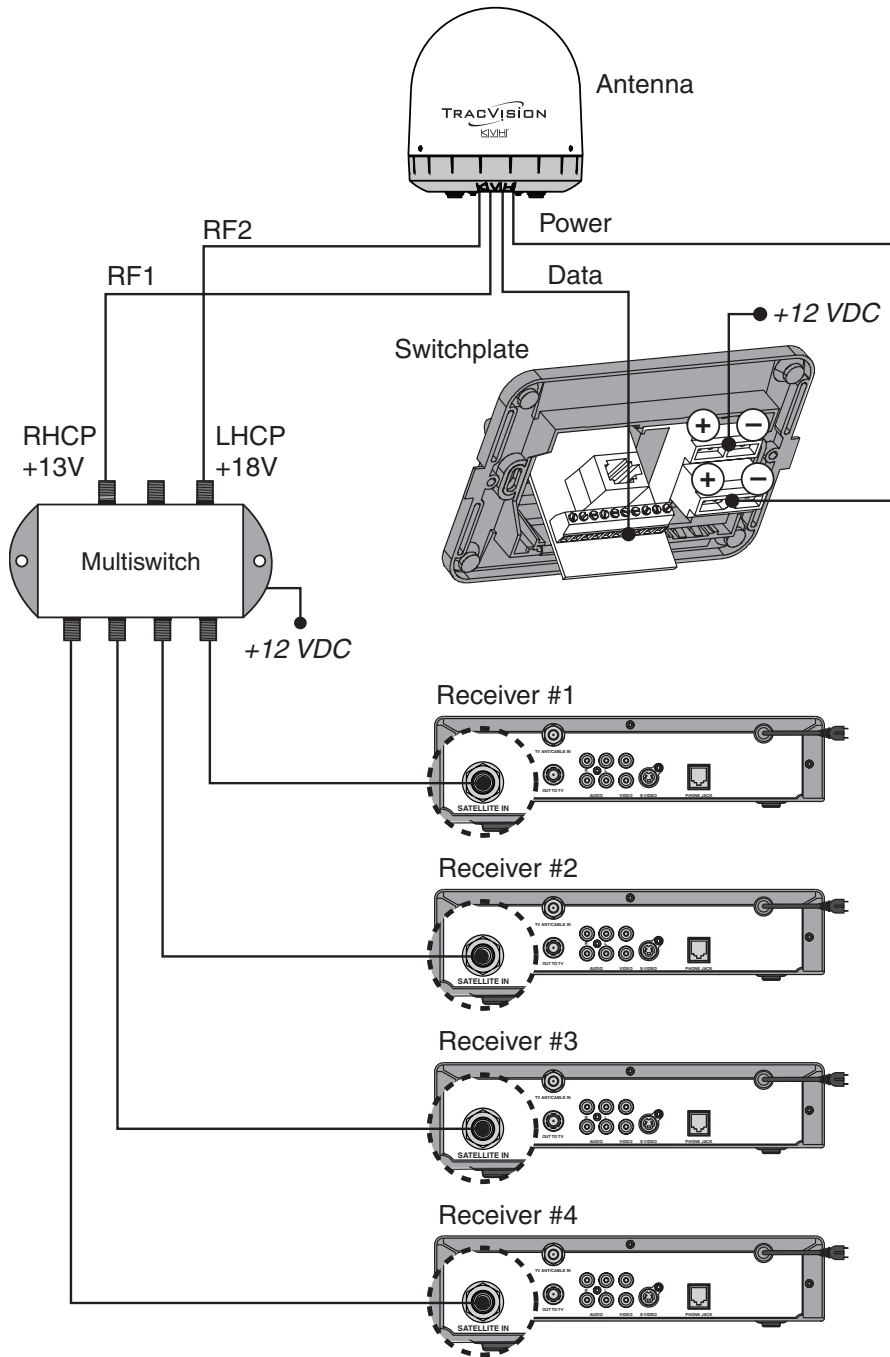

**\*NOTE:** This configuration requires an active (powered) multiswitch, such as Channel Master model 6314IFD. You can purchase this multiswitch from KVH (KVH P/N 19-0123). Be sure to terminate all unused output connectors with 75 ohm DC blocks (Channel Master model #7184 or equivalent). This configuration also requires the use of either a PC or an optional TV/SAT Switch (KVH P/N 01-0245) to switch between satellites.

## TracVision M7 Wiring Diagram for Three or Four Receivers (Linear Quad-output Version Only)

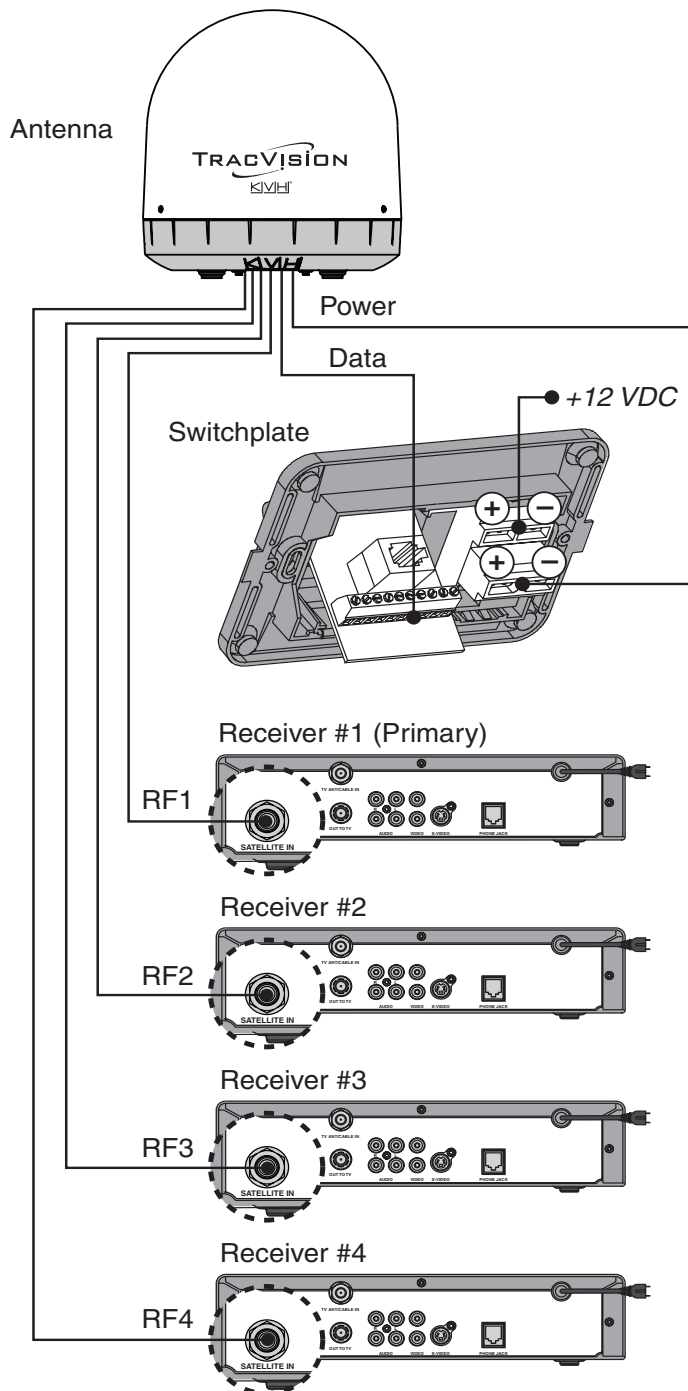

**NOTE:** If you wish to connect more than four receivers, you will need to install an active (powered) multiswitch, such as Spaun model 5602NF. You can purchase this multiswitch from KVH (KVH P/N 19-0413). Be sure to terminate all unused output connectors with 75 ohm DC blocks (Channel Master model #7184 or equivalent). The installation of a multiswitch also requires the use of either a PC or an optional TV/SAT Switch (KVH P/N 01-0245) to switch between satellites.



# Appendix C

# Optional PC Functions

This appendix explains how to use a PC to perform optional functions.

## Contents

Connecting a PC to the Antenna .....	55
Programming Your User-defined Satellite(s) .....	57
Using a PC to Switch Between Satellites .....	62

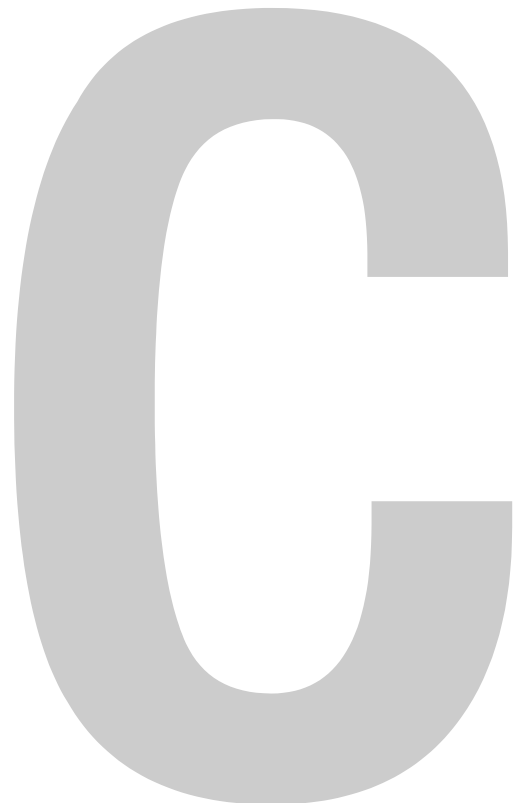

## Connecting a PC to the Maintenance Port

To program your user-defined satellite(s), you first need to connect a PC with Windows HyperTerminal installed.

*TIP: If you are a KVH-authorized technician, you can use the KVH Flash Update Wizard instead of HyperTerminal. Enter commands in the wizard's "Antenna Comms" window. You do not need to flash the antenna to enter commands.*

1. Set the switchplate's power switch to the Off (down) position.

Figure C-1 Switchplate Power Switch and Maintenance Port

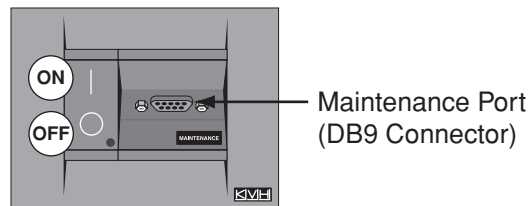

2. Connect one end of a straight serial data cable to the maintenance port (DB9 connector) located on the switchplate. Connect the other end of the data cable to the serial port on your PC.

*TIP: If your computer does not have a DB9 serial COM port, you can use the following USB-to-RS232 adapters: IO Gear Part # GUC232A (visit [www.iogear.com](http://www.iogear.com)) or Belkin Part # F5U109 (visit [www.belkin.com](http://www.belkin.com)).*

3. Open HyperTerminal and establish the following settings:
  - Bits per second: 9600
  - Data bits: 8
  - Parity: None
  - Stop Bits: 1
  - Flow Control: None

Figure C-2 HyperTerminal Settings



**TIP:** To view characters on the screen as you type, set up HyperTerminal to echo typed characters. Select "Properties" from the File menu; select "ASCII Setup" at the Settings tab; then select "Echo typed characters locally" at the ASCII Setup window.

4. Set the switchplate's power switch to the On (up) position. Wait one minute for the system to initialize.



## Programming Your User-defined Satellite(s)

To configure a user-defined satellite, you will need to program the following satellite information into the antenna:

- Satellite name
- Satellite longitudinal position
- Transponder information for all applicable combinations of polarization/band:
  - Frequency
  - Symbol rate
  - FEC code
  - Network ID
  - Decoder type

***TIP:** Linear satellites use the following polarization/band combinations: vertical high, vertical low, horizontal high, and horizontal low. Circular satellites use the following polarizations: right and left.*

***NOTE:** You can find satellite information on the web at [www.lyngsat.com](http://www.lyngsat.com) or [www.satcodx.com](http://www.satcodx.com) (neither website is affiliated with KVH).*

1. Connect a PC to the maintenance port, as described in *[“Connecting a PC to the Maintenance Port” on page 55.](#)* Then type the following commands in the HyperTerminal window.
2. Type **HALT** then press Enter.

3. Type the following **SATCONFIG** command then press Enter:

**SATCONFIG,X,A,B,C,D**

Field	Description
X	User-defined satellite stored in antenna library (User1 = User-defined Satellite 1 or User2 = User-defined Satellite 2)
A	Longitude (0-180)
B	E (East) or W (West)
C	Decoding type (2 = DSS, 3 = DVB)
D	Polarization (L = linear) (C = circular)

4. Type **@DEBUGON** then press Enter.
5. Type the following **@SATCONFIG** command then press Enter:

**@SATCONFIG,X,E,F,G,H,I,J,K**

Field	Description
X	User-defined satellite stored in antenna library (User1 = User-defined Satellite 1 or User2 = User-defined Satellite 2)
E	Frequency, MHz (00000 or 10700-12750)
F	Symbol rate, kilosymbols per second (10000-45000)
G	FEC code (12, 23, 34, 56, 67, or 78)
H	Network ID, hexadecimal (0x####)
I	Polarization (V = vertical; H = horizontal; R = right; L = left)
J	LNB down conversion frequency (U = USA [11250 MHz]; L = low [9750 MHz]; H = high [10600 MHz]; G = Latin America [10500 MHz]; S = Sinosat [11300 MHz])
K	Decoding type (2 = DSS, 3 = DVB)

**6a. (Linear systems only)** - Repeat Step 5 for each polarization/band:

- Vertical High
- Horizontal High
- Vertical Low
- Horizontal Low

**6b. (Circular systems only)** - Repeat Step 5 for each polarization:

- Right
- Left

If your selected satellite does not have information for one or more of these transponder categories, you can enter the following defaults instead:

Transponder Data	Default Value
Frequency	00000
Symbol rate	27500
FEC code	Same value as other transponders with valid data
Network ID	0x0000

7. Type **ZAP** then press Enter. The antenna restarts. Wait one minute for system startup.
8. Follow the steps in *"Programming the Antenna to Track Different Satellites"* on page 24 to select your new user-defined satellite(s) for tracking. Be sure use the following installation names for your user-defined satellite(s):

Satellite	Installation Name
User-defined Satellite 1	USER1
User-defined Satellite 2	USER2

## Example - Linear Satellite

The following is an example of programming the fictional "YOURSAT 7" as the USER1 user-defined satellite.

### YOURSAT 7 at 7°W, DVB decoder, linear polarization

Transponder Data	Value
<i>Horizontal High</i>	
Frequency	11.966 GHz
Symbol rate	27500
FEC code	3/4
Network ID	2048 (dec) = 0x0800
<i>Vertical High</i>	
Frequency	11.823 GHz
Symbol rate	27500
FEC code	3/4
Network ID	2048 (dec) = 0x0800
<i>Vertical Low</i>	
No data listed	
<i>Horizontal Low</i>	
No data listed	

Based on the above information, you would enter the following commands into the HyperTerminal window:

```

HALT
SATCONFIG,USER1,7,W,3,L
@DEBUGON
@SATCONFIG,A,11966,27500,34,0x0800,H,H,3
@SATCONFIG,A,11823,27500,34,0x0800,V,H,3
@SATCONFIG,A,00000,27500,34,0x0000,V,L,3
@SATCONFIG,A,00000,27500,34,0x0000,H,L,3
ZAP
    
```

## Example - Circular Satellite

The following is an example of programming the fictional "YOURSAT 122" as the USER2 user-defined satellite.

### YOURSAT 122 at 122°W, DVB decoder, circular polarization

Transponder Data	Value
<i>Right</i>	
Frequency	12.225 GHz
Symbol rate	20000
FEC code	5/6
Network ID	4100 (dec) = 0x1004
<i>Left</i>	
Frequency	12.456 GHz
Symbol rate	20000
FEC code	5/6
Network ID	4100 (dec) = 0x1004

Based on the above information, you would enter the following commands into the HyperTerminal window:

```

HALT
SATCONFIG,USER2,122,W,3,C
@DEBUGON
@SATCONFIG,B,99,12225,20000,56,0x1004,R,U,3
@SATCONFIG,B,99,12456,20000,56,0x1004,L,U,3
ZAP
    
```

## Using a PC to Switch Between Satellites

The following instructions explain how to use a PC to switch between satellites. This procedure requires a PC with Windows® HyperTerminal and a straight serial data cable.

*TIP: If you are a KVH-authorized technician, you can use the KVH Flash Update Wizard instead of HyperTerminal. Commands can be typed into the wizard's "Antenna Comms" window. You do not need to flash the antenna to enter commands.*

1. Connect a PC to the maintenance port, as described in *"Connecting a PC to the Maintenance Port" on page 55*. Then type the following commands in the HyperTerminal window.
  - 2a. To switch to Satellite A, type the following command in the HyperTerminal window then press Enter.  
**@L,A**
  - 2b. To switch to Satellite B, type the following command in the HyperTerminal window then press Enter.  
**@L,B**
3. The antenna shifts to track the second satellite.



# Appendix D Position Grids

This appendix contains European and North American position grids for determining your approximate latitude and longitude.

## Contents

European Position Grid ..... 65  
North American Position Grid ..... 66

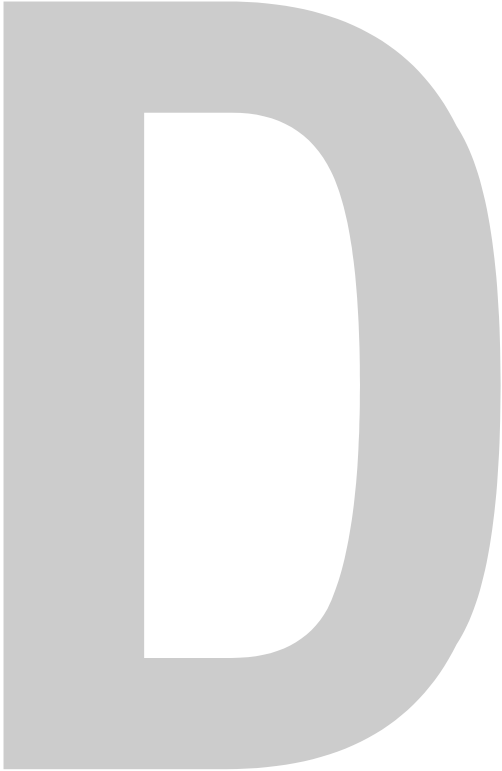

# European Position Grid

If you wish to determine your approximate latitude and longitude, use the position grid and table in [Figure D-1](#).

Figure D-1 Approximate Latitude and Longitude

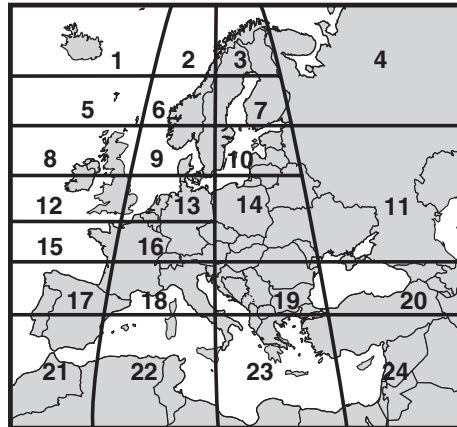

Grid #	Latitude	Longitude
1	67° N	7° W
2	67° N	7° E
3	67° N	22° E
4	65° N	45° E
5	63° N	7° W
6	63° N	7° E
7	63° N	22° E
8	57° N	7° W
9	57° N	7° E
10	57° N	22° E
11	55° N	40° E
12	53° N	7° W
13	53° N	7° E
14	50° N	22° E
15	47° N	7° W
16	47° N	7° E
17	43° N	7° W
18	43° N	7° E
19	43° N	22° E
20	43° N	37° E
21	36° N	7° W
22	36° N	7° E
23	36° N	22° E
24	36° N	37° E

## North American Position Grid

If you wish to determine your approximate latitude and longitude, use the position grid and table in [Figure D-2](#).

Figure D-2 Approximate Latitude and Longitude

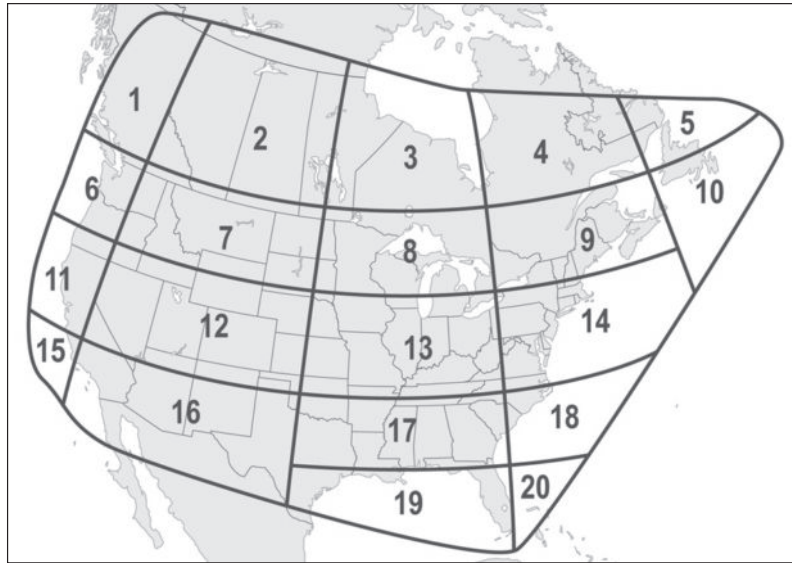

Grid #	Latitude	Longitude
1	55° N	125° W
2	55° N	110° W
3	55° N	90° W
4	55° N	70° W
5	55° N	55° W
6	45° N	125° W
7	45° N	110° W
8	45° N	90° W
9	45° N	70° W
10	45° N	50° W
11	40° N	125° W
12	40° N	110° W
13	40° N	90° W
14	40° N	70° W
15	32° N	125° W
16	32° N	110° W
17	32° N	90° W
18	32° N	75° W
19	27° N	83° W
20	27° N	78° W



**KVH Industries, Inc.**

50 Enterprise Center Middletown, RI 02842-5279 U.S.A.  
Phone: +1 401 847-3327 Fax: +1 401 849-0045  
E-mail: [info@kvh.com](mailto:info@kvh.com) Internet: [www.kvh.com](http://www.kvh.com)

**KVH Europe A/S**

Kokkedal Industripark 2B 2980 Kokkedal Denmark  
Phone: +45 45 160 180 Fax: +45 45 160 181  
E-mail: [info@kvh.dk](mailto:info@kvh.dk) Internet: [www.kvh.com](http://www.kvh.com)