

TRACVISION[®]
BY KVH INDUSTRIES

TracVision M7

Control Panel Configuration



TracVision M7 Installation Guide

TracVision® M7 Installation Guide

MultiSat Control Panel (MCP) Configuration

These instructions explain how to install the TracVision M7 satellite TV antenna system on a vessel. Complete instructions on how to use the system are provided in the *User's Guide*.

Installation Steps

| | | | |
|---|----|---------------------------------------|----|
| 1. Inspect Parts and Get Tools | 3 | 10. Wire the MCP and Receivers..... | 12 |
| 2. Plan the Antenna Installation | 4 | 11. Connect Power | 14 |
| 3. Plan the Belowdecks Installation | 5 | 12. Mount the Switchplate & MCP | 15 |
| 4. Prepare the Belowdecks Sites | 6 | 13. Turn On the System..... | 16 |
| 5. Prepare the Antenna Site..... | 7 | 14. Choose an Operating Mode..... | 17 |
| 6. Remove the Restraint..... | 8 | 15. Select Satellites..... | 18 |
| 7. Wire the Antenna | 9 | 16. Set the LNB Skew Angle | 24 |
| 8. Mount the Antenna | 10 | 17. Run a Check Switch Test..... | 25 |
| 9. Wire the Switchplate..... | 11 | 18. Educate the Customer | 27 |

Who Should Install the System?

To ensure a safe and effective installation, KVH recommends that a KVH-authorized marine technician install the TracVision antenna. KVH-authorized technicians have the tools and electronics expertise necessary to install the system. To find a technician near you, visit www.kvh.com/wheretogetservice.

Linear vs. Circular Systems

The installation process differs slightly depending on the type of LNB (low noise block) that is installed in the antenna (linear or circular). These differences are noted throughout this manual. Appendix B on page 33 notes the satellites available for each LNB type and geographic region.

Technical Support

If you need technical assistance, please contact KVH Technical Support:

North/South America, Australia:
Phone: +1 401 847-3327
E-mail: techs@kvh.com
(Mon.-Fri., 9 am-6 pm ET, -5 GMT)
(Sat., 9 am-2 pm ET, -5 GMT)

Europe, Middle East, Asia:
Phone: +45 45 160 180
E-mail: support@kvh.dk
(Mon.-Fri., 8 am-4:30 pm, +1 GMT)

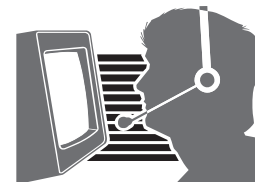

1 Inspect Parts and Get Tools

Before you begin, make sure you have everything you need to complete the installation.

- a. Unpack the box and ensure it contains everything shown on the *Kitpack Contents List*. Save the packaging for future use.

IMPORTANT!

Always lift the antenna by the baseplate and never by the radome or any portion of the internal antenna assembly (see Figure 1).

- b. Carefully examine all of the supplied parts to ensure nothing was damaged in shipment.
- c. Gather all of the tools and materials listed below. You will need these items to complete the installation.
 - Flat-head and Phillips-head screwdrivers
 - Electric drill and 1/2" (13 mm), 5/32" (4 mm), 3/32" (2.25 mm), and #29 bits
 - 3" (80 mm) hole saw
 - Socket wrenches
 - 7/16" open-end wrench
 - Torque wrench and 2 mm allen hex key (*only required for linear systems without Auto Skew capability*)
 - Light hammer and center punch
 - Adhesive tape and scribe or pencil
 - Wire strippers and terminal lug crimper
 - RG-6 or RG-11 RF coax cable(s) with Snap-N-Seal® F-connectors; see Step 7a on page 9 for quantity and type required
 - Augat IT1000 connector installation tool
 - Power cables (see Figure 2)
 - Silicone sealant, self-vulcanizing tape, or equivalent
 - Satellite TV receiver and TV (*see Figure 3 for a list of validated U.S./Canadian receivers*)

Figure 1: TracVision M7 System Components

Antenna

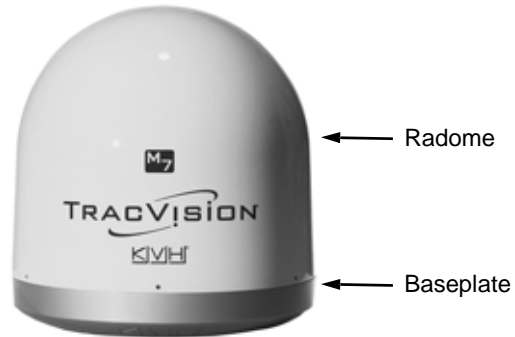

Switchplate



MCP (MultiSat Control Panel)



Figure 2: Guidelines for Power Cables

| Cable Length | Use Cable Gauge |
|--------------------|-----------------------------|
| < 40 ft (12 m) | 14AWG (2.5mm ²) |
| 40-70 ft (12-21 m) | 12AWG (4mm ²) |

Figure 3: KVH-Validated U.S./Canadian Receivers

| Standard-Definition Models | | |
|-----------------------------|--------------|--------------|
| DIRECTV | DISH Network | Bell TV |
| D12 | 311 | 4100 |
| D11 | 211k | 3100 |
| D10 | 211 | |
| High-Definition (HD) Models | | |
| DIRECTV | DISH Network | Bell TV |
| HD not supported | 211k 211 | 6100 6131 |

2 Plan the Antenna Installation

Consider the following antenna installation guidelines:

- Minimize blockage. The antenna requires a clear view of the sky to receive satellite TV (see Figure 4). The fewer obstructions, the better the system will perform.
- Make sure the mounting surface is wide enough to accommodate the antenna's base (see Figure 5). Also make sure it is flat, level (within $\pm 1^\circ$), strong enough to support the antenna's weight (55 lbs, 25 kg), and rigid enough to withstand vibration.
- Select a location that is as close as possible to the intersection of the vessel's fore-and-aft centerline and midships.
- Do not mount the antenna at the same level as the radar because the radar's energy might overload the antenna. Ideally, you should mount the antenna 4 ft (1.2 m) above the radar, outside the beam path of the radar.

IMPORTANT!

Be sure to follow the guidelines above. Damage caused by an improper installation is not covered under KVH warranty.

Figure 4: Blockage from Obstruction

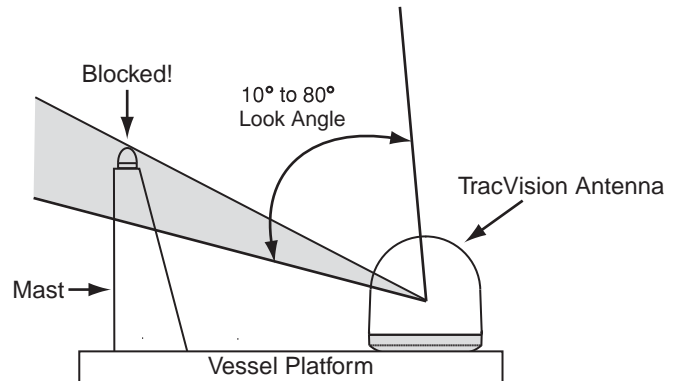
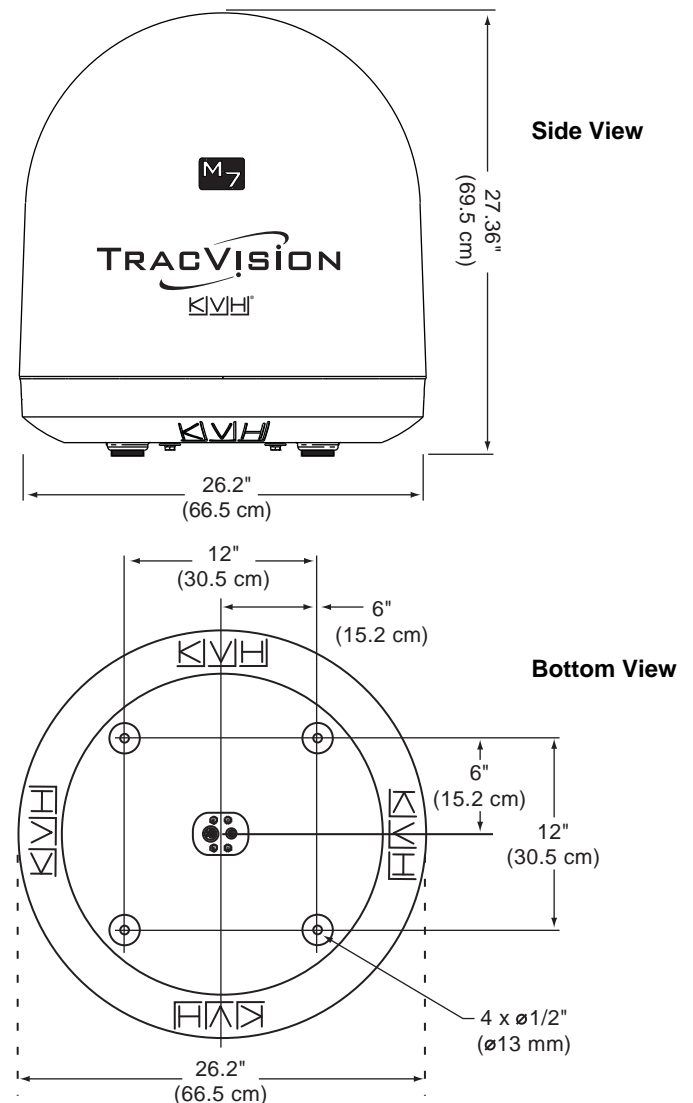

Figure 5: Antenna Dimensions



3 Plan the Belowdecks Installation

Consider the following belowdecks equipment installation guidelines.

Switchplate

- Select a switchplate mounting location in a dry, well-ventilated area belowdecks away from any heat sources or salt spray.
- Be sure to leave enough room at the switchplate's rear panel for connecting the cables and maintaining a service loop (see Figure 6 for switchplate dimensions).
- The supplied data cable is 100 ft (30 m) long. Be sure to locate the switchplate close enough to the antenna for the cable to reach, while allowing adequate slack for a service loop.
- **(Circular and Sky Mexico only)** The grounding block should be located within 95 ft (28 m) of the antenna, within 5 ft (1.5 m) of the primary receiver, and within 25 ft (7.6 m) of a suitable vessel AC ground.
- The switchplate mounting template at the end of this manual shows the size of the hole required for a flush-mount installation.

Figure 6: Switchplate Dimensions

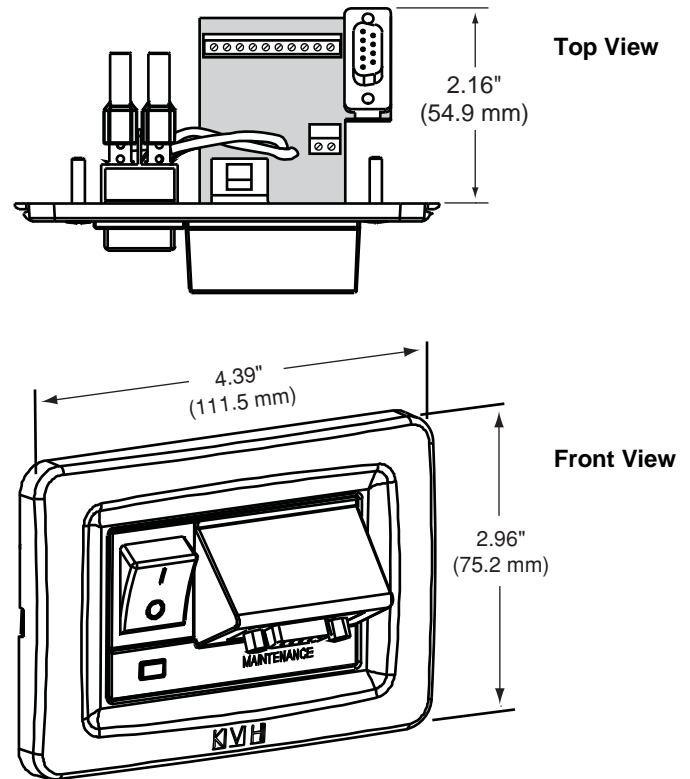

MCP

- Select an MCP mounting location in a dry, well-ventilated area belowdecks away from any heat sources or salt spray.
- Be sure the MCP's front panel will be easily accessible to the user.
- Be sure to leave enough room at the MCP's rear panel for connecting the cables (see Figure 7 for MCP dimensions).
- Since the supplied main control cable and RF control cable are 25 ft (7.6 m) long, the MCP must be located within 25 ft (7.6 m) of the switchplate. Later, you will connect the MCP to the switchplate using these special cables.
- The kitpack contains parts for mounting the MCP either to a horizontal surface (using Velcro) or to a vertical surface (using the supplied flush mount bracket). The MCP mounting template at the end of this manual shows the size of the hole required for a flush-mount installation.

Figure 7: MCP Dimensions

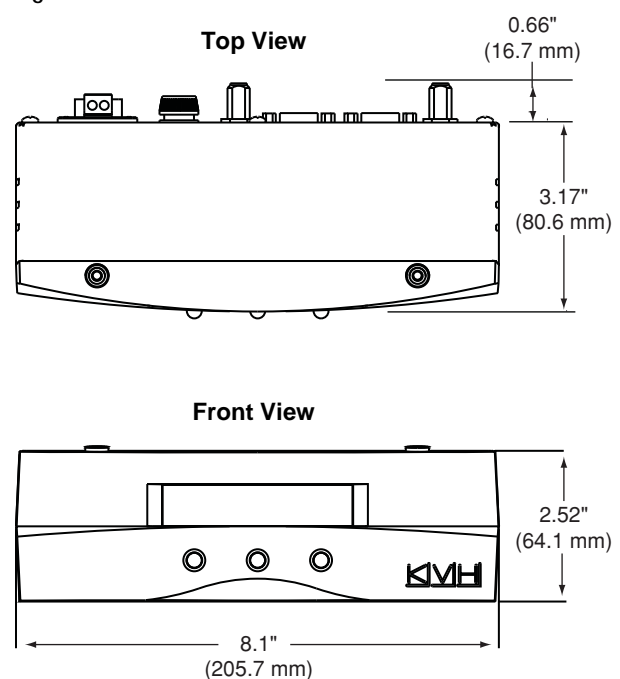

4 Prepare the Belowdecks Sites

Once you have identified suitable mounting sites for the switchplate and MCP, follow these steps to prepare the sites for installation.

Switchplate

- Using the switchplate mounting template provided at the end of this manual, mark and cut out a hole in the mounting surface to accommodate the switchplate (see Figure 8).
- Using the same template, mark the locations for the four switchplate mounting holes.
- Drill a $\frac{3}{32}$ " (2.25 mm) hole at the four mounting hole locations. Later, you will mount the switchplate using four #6 screws.

MCP (Flush Mount only)

NOTE: Skip this step if you plan to mount the MCP to a horizontal surface instead; proceed to page 7.

- Attach the supplied flush mount bracket to the MCP now, before you connect any cables. Simply slide the bracket onto the MCP from behind and position the front edge of the bracket over the seam line between the front bezel and the chassis. Secure the bracket in place using two #6-32 screws and washers (see Figure 9).
- Using the MCP flush mounting template provided at the end of this manual, mark and cut out a hole in the mounting surface to accommodate the flush mount bracket (see Figure 10).
- Using the same template, mark the locations for the four MCP mounting holes.
- Using a #29 drill bit, drill a 0.136 " (3.45 mm) hole at the four mounting hole locations. Later, you will mount the MCP using four #8 screws.

Figure 8: Switchplate Mounting Holes Layout

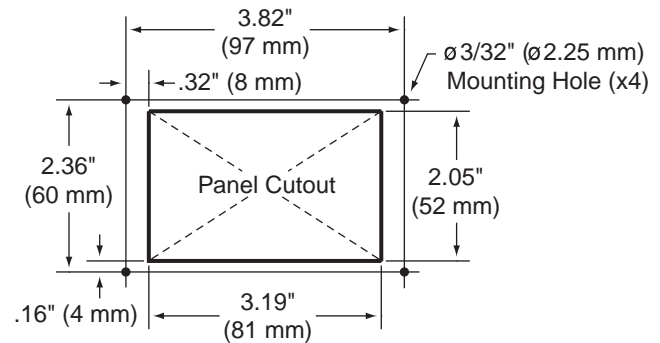

Figure 9: MCP Flush Mount Bracket

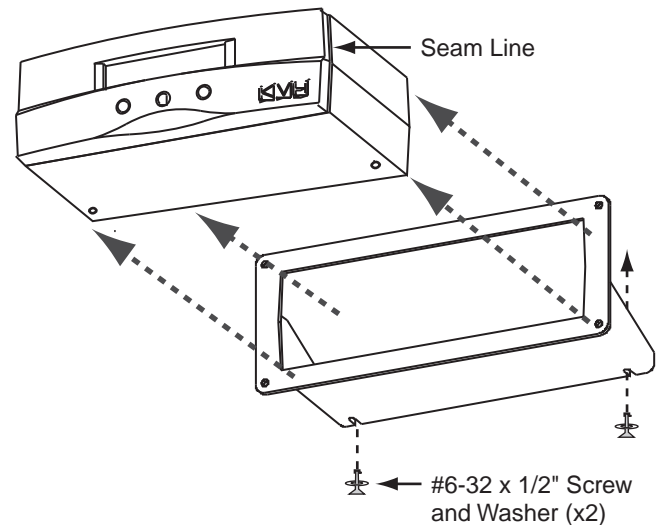
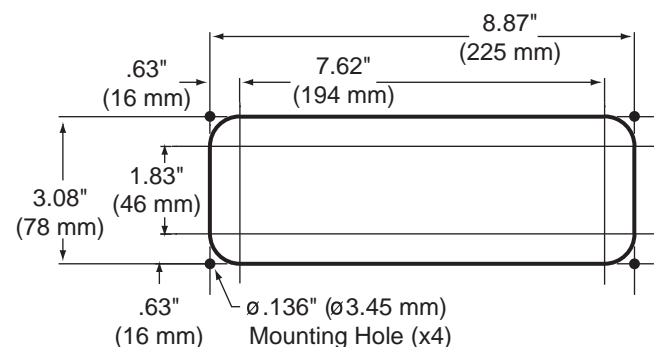

Figure 10: MCP Mounting Holes Layout



5 Prepare the Antenna Site

Once you have identified a suitable antenna mounting site, according to the guidelines provided on page 4, follow these steps to drill the mounting holes and cable access hole to prepare the site for installation.

- a. Unfold the antenna mounting template (supplied in the Customer Welcome Kit) and place it onto the mounting surface. Make sure the “FWD” (forward) arrow points toward the bow and is parallel to the vessel’s centerline (see Figure 11).

NOTE: You don’t need to mount the antenna exactly on the vessel’s centerline (the closer, the better), but the antenna’s forward arrow must be parallel to it.

- b. Using a light hammer and center punch, mark the locations for the four mounting holes and cable access hole on the mounting surface in the locations indicated on the template.
- c. Drill a 1/2" (13 mm) hole at the four mounting hole locations you marked in Step b. Later, you will insert four 3/8"-16 bolts through these holes to secure the antenna to the mounting surface.
- d. Cut out the 3" (80 mm) cable access hole in the location you marked in Step b. Smooth the edges of the hole to protect the cables. Later, you will route the data, power, and RF cables through this hole and into the vessel.
- e. Clean and dry the antenna mounting surface.
- f. Peel off the paper backing from the supplied foam seal to expose the adhesive. Then press the foam seal down firmly onto the mounting surface, ensuring the hole in the foam seal aligns with the cable access hole in the mounting surface (see Figure 12).

NOTE: Apply the foam seal to the vessel mounting surface, not to the antenna’s baseplate. You will have difficulty connecting the cables to the antenna if the foam seal is attached to the baseplate.

Figure 11: Antenna Mounting Holes Layout

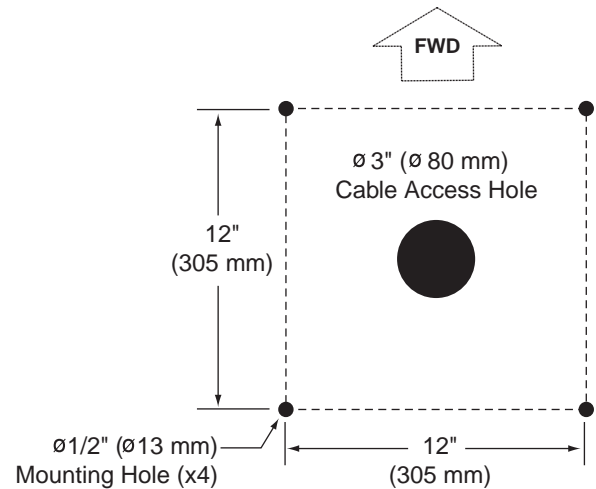

Figure 12: Foam Seal



6 Remove the Restraint

Inside the antenna, a foam block prevents the antenna assembly from moving during shipment. Follow these steps to remove this shipping restraint.

- a. Remove the six #10-32 Phillips screws securing the radome to the baseplate (see Figure 13). Carefully lift the radome straight up until clear of the antenna assembly and set it aside in a safe place.

TIP: If you keep the radome topside, secure it with a lanyard to prevent it from falling overboard.

- b. Remove the foam block that is wedged beneath the antenna's reflector (see Figure 14). Save this restraint for future use; the customer will need to reinstall it if he/she needs to relocate or reship the antenna.

IMPORTANT!

Once you have removed the restraint, keep the antenna level as much as possible and handle the antenna very carefully. Prevent the internal antenna assembly from rotating freely within the baseplate to avoid damaging the limit switch.

Figure 13: Removing the Radome

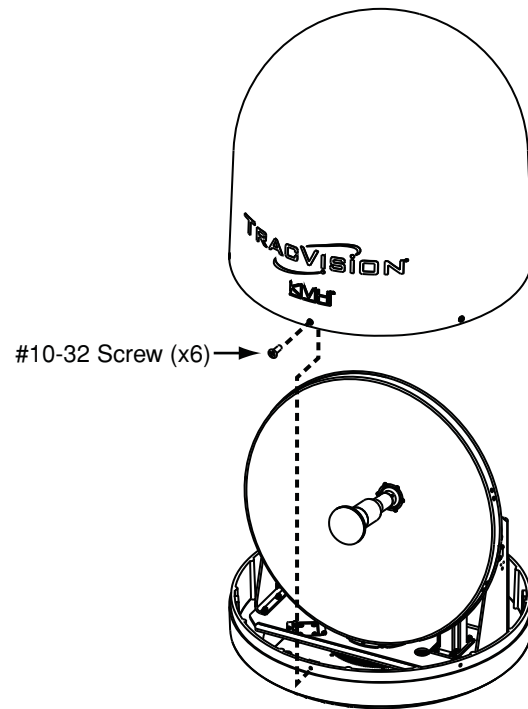
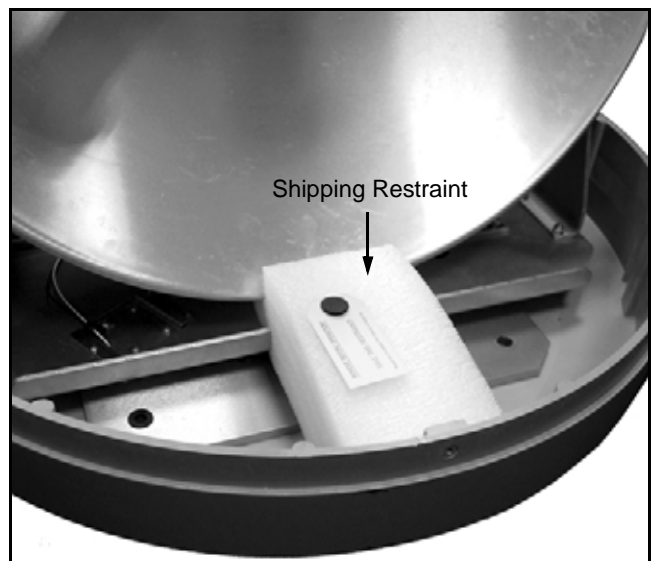

Figure 14: Foam Block Shipping Restraint



7 Wire the Antenna

Follow these steps to connect the data, power, and RF cables to the antenna.

- a. First determine the number of RF coax cables you need to connect to the antenna for your particular installation (see Figure 15). (See Figure 16 to determine the type of cable required.)
- b. Route the data, power, and RF cables belowdecks through the 3" (80 mm) cable access hole. Leave an adequate service loop, approximately 8" (20 cm) of slack, in the cables for easy serviceability. Later, you will connect the data and power cables to the switchplate and the RF cable(s) to the receiver(s).
- c. Connect the data cable to the "Data" connector on the bottom of the antenna (see Figure 17). Hand-tighten until the cable locks in place; do not use excessive force.
- d. Connect the power cable to the "Power" connector on the bottom of the antenna. Hand-tighten until the cable locks in place; do not use excessive force.
- e. Connect the RF coax cable(s) to the antenna. If you need to connect just one RF cable, connect the cable to the "RF1" connector on the bottom of the antenna. Hand-tighten, then tighten with a 7/16" wrench for 1/4 turn to ensure an electrical connection. Connect any additional RF coax cables to the antenna's RF2, RF3, and RF4 connectors, in that order.

TIP: If you connect two or more RF cables, label both ends of each cable to match the connector. This will make it easier to identify the cables later.

- f. Seal the RF cable connections with silicone sealant, self-vulcanizing tape, or equivalent.

Figure 15: Number of RF Coax Cables to Connect to Antenna

| Connecting to: | # RF Cables |
|--------------------------------------|-------------|
| <i>System with Circular Dual LNB</i> | |
| 1 receiver | 1 |
| 2 or more receivers | 2* |
| <i>System with Linear Dual LNB</i> | |
| 1 receiver | 1 |
| 2 receivers | 2 |
| <i>System with Linear Quad LNB</i> | |
| 1 receiver | 1 |
| 2 receivers | 2 |
| 3 receivers | 3 |
| 4 or more receivers | 4* |

* Multiswitch required for additional receivers.

Figure 16: RF Cable Guidelines

| Cable Length | Use Cable Type |
|-----------------|----------------|
| <= 75 ft (23 m) | RG-6 |
| > 75 ft (23 m) | RG-11 |

Figure 17: Connectors on Bottom of Antenna

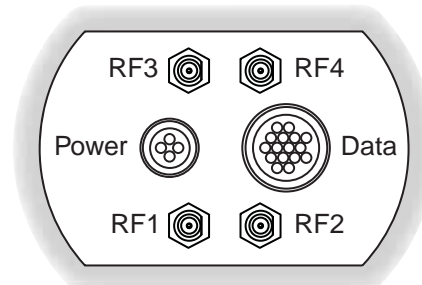

8 Mount the Antenna

Follow these steps to mount the antenna to the mounting surface.

- a. Place the antenna baseplate over the holes drilled in the mounting surface. Ensure the forward arrow inside the baseplate points toward the bow and is parallel to the vessel's centerline (see Figure 18).

IMPORTANT!

You will need to rotate the antenna assembly by hand to see all four mounting holes. Rotate the antenna assembly slowly. If it hits a mechanical stop with excessive force, the limit switch might become damaged.

- b. At each of the four baseplate mounting holes, place a 3/8" flat washer on a 3/8"-16 bolt and insert the bolt into the hole (with preinstalled 3/8" shoulder washer) from above (see Figure 19).

NOTE: To enable proper grounding, ensure the preinstalled shoulder washers are in place, and were not dislodged during handling (see Figure 19).

- c. Secure each mounting bolt to the mounting surface using a 3/8" shoulder washer, a 3/8" flat washer, and a 3/8"-16 lock nut from below. Tighten all four bolts until the four rubber feet on the baseplate are bottomed against the mounting surface and the foam seal is fully compressed. KVH recommends that you tighten the bolts to between 12 and 16 ft-lbs (16.2 and 21.7 N-m) of torque.

TIP: If you are installing a linear system that does not have Auto Skew capability, keep the radome off for now. You will need to adjust the skew angle of the antenna's LNB.

- d. Reinstall the radome onto the antenna. Secure in place with the six #10-32 screws you removed in Step 6.
- e. Install a protective plastic screw cap (supplied in the kitpack) over each radome screw.

Figure 18: Forward Arrow in Antenna Baseplate

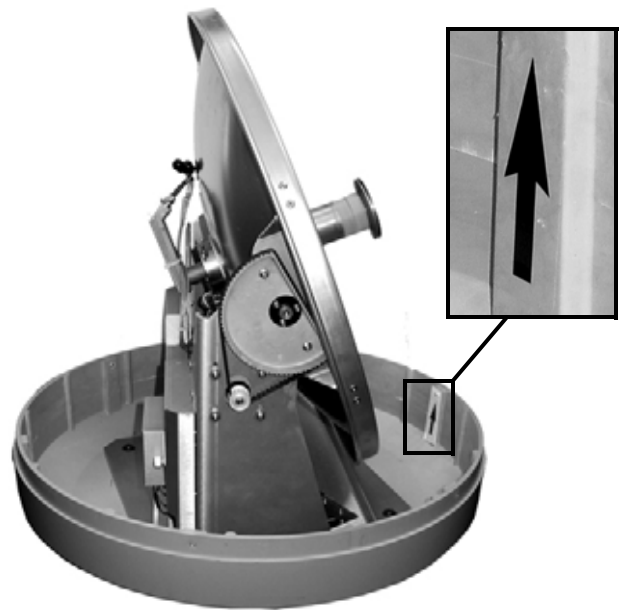
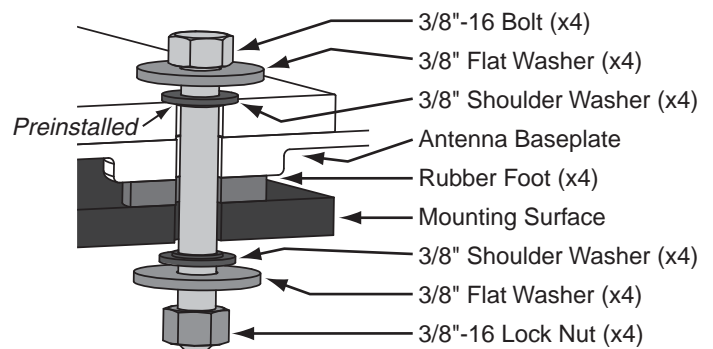

Figure 19: Mounting the Antenna (Side View)



9 Wire the Switchplate

Follow these steps to connect the switchplate to the antenna.

- a. First dress the data and power cables from the antenna. Strip back the insulation of each wire approximately 1/4" (6 mm) and gently twist each wire to ensure a good electrical connection.
- b. Connect the data cable from the antenna to the terminal board on the back of the switchplate (see Figure 20). Be sure to match the wire colors with the terminal board label. Tighten the terminal screws to secure all wires in place.

IMPORTANT!

The diagram refers to wires by **body color/stripe color**. For example, "Brown/White" means the brown wire with the white stripe.

IMPORTANT!

Do not connect the data cable's drain wire (shield) to anything. You can simply snip it from the cable.

- c. Connect the power cable from the antenna to the switchplate's power output terminals (see Figure 21). Later, you will also connect a power cable from these terminals to the MCP.

Figure 20: Switchplate Wiring - Antenna Data Cable

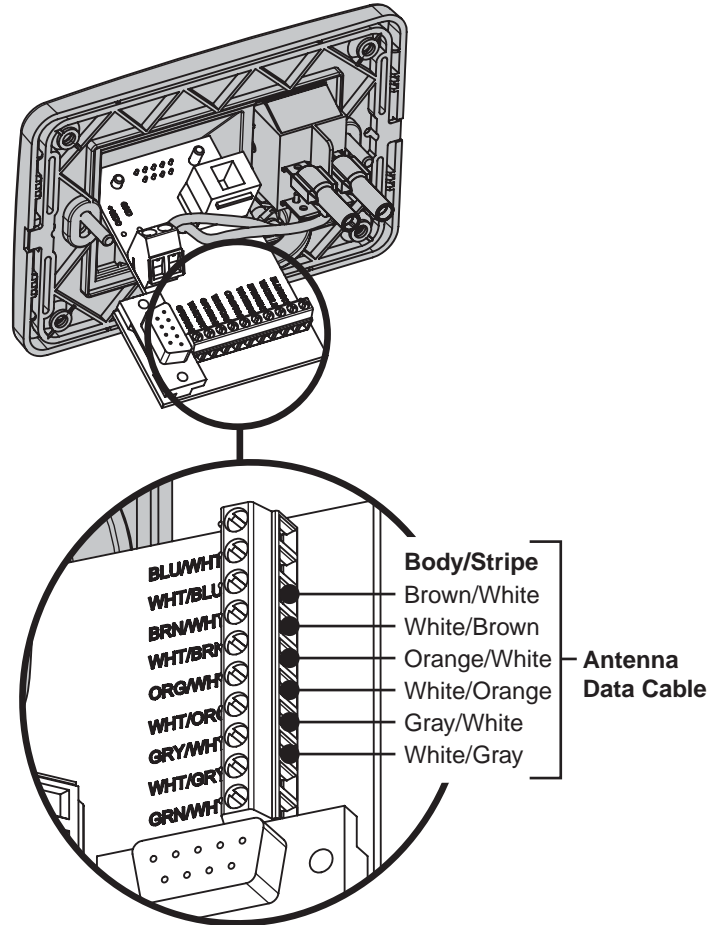
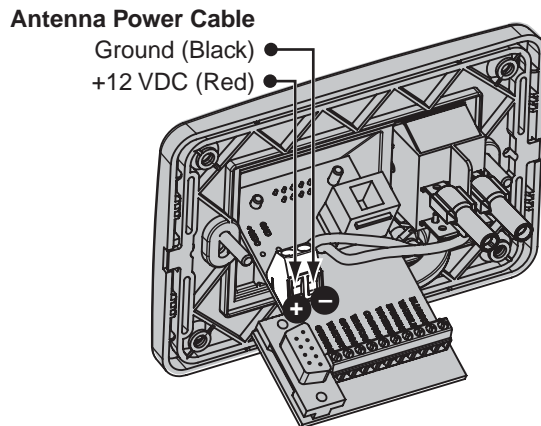

Figure 21: Switchplate Wiring - Antenna Power Cable



10 Wire the MCP and Receivers

Circular and Sky Mexico

If you are installing a **circular** system, or a linear system for **Sky Mexico**, follow these steps to connect the switchplate to the MCP and the antenna to the receiver(s).

- a. Connect the main control cable (DB9-male to DB9-male) from the “Maintenance” port on the **front or back** of the switchplate to the “Antenna Unit” connector on the MCP (see Figure 22).

NOTE: The switchplate’s two DB9 connectors access the same port. Connecting to one disables the other.

- b. Connect the RF control cable (RJ22 to DB9-female) from the RJ22 jack on the back of the switchplate to the “RF Port” connector on the MCP.
- c. Connect the RF1 cable from the antenna to the grounding block, as shown in Figure 22. Label this grounding block connector “RF1.”
- d. If you are connecting multiple receivers, connect the RF2 cable from the antenna to the grounding block. Label this connector “RF2.”
- e. Attach the supplied ground wire to either ground screw on the grounding block. Connect the other end of the wire to a suitable vessel AC ground.
- f. Using the two supplied #6 screws, mount the grounding block inside the vessel.

IMPORTANT!

If you wish to connect **three or more** receivers to the antenna, see Appendix A on page 31 (circular) or page 32 (Sky Mexico).

- g. Connect the supplied 5-ft RF cable from the “RF1” connector on the grounding block to the “Satellite In” connector on the primary receiver.
- h. If you are connecting two receivers, connect an RF cable from the “RF2” connector on the grounding block to the “Satellite In” connector on the secondary receiver.
- i. Connect the receiver(s) to the customer’s television(s). Follow the instructions in the receiver’s manual

Figure 22: MCP and Receiver Wiring

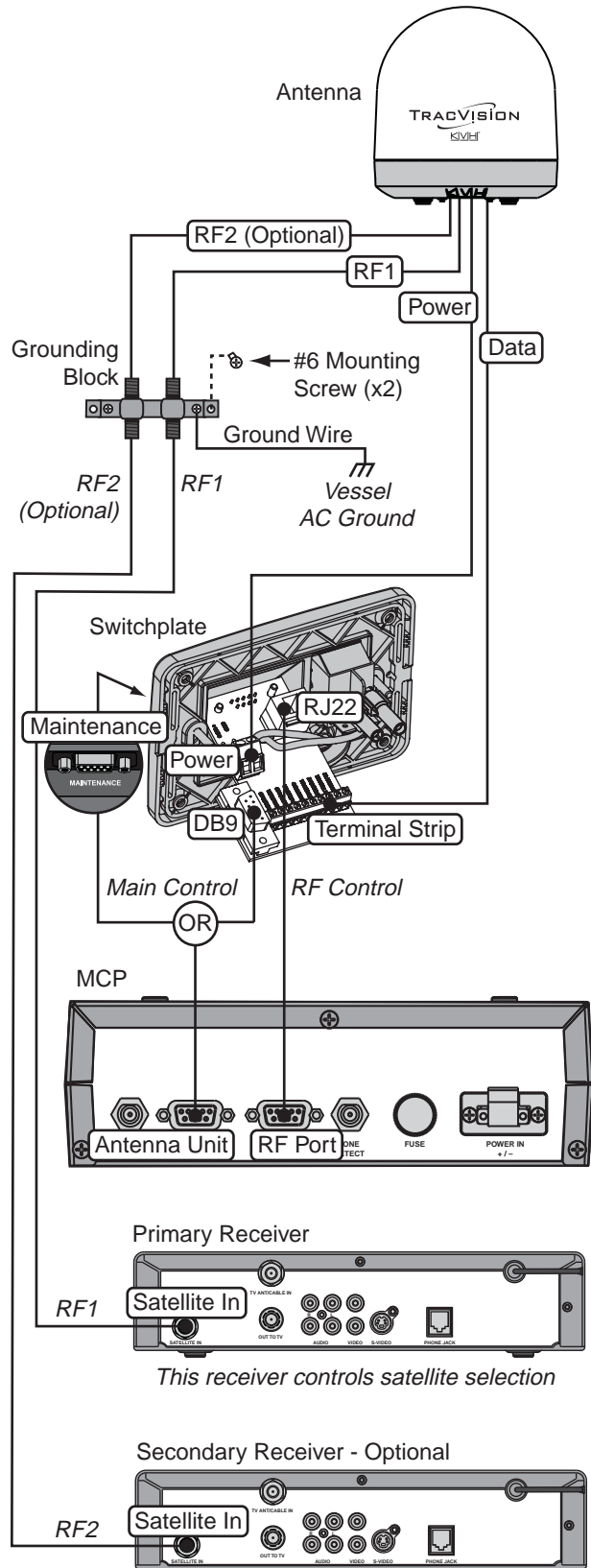

10 Wire the MCP and Receivers

Linear Systems

If you are installing a **linear** system (with the exception of Sky Mexico), follow these steps to connect the switchplate to the MCP and the antenna to the receiver(s).

- a. Connect the main control cable (DB9-male to DB9-male) from the “Maintenance” port on the **front or back** of the switchplate to the “Antenna Unit” connector on the MCP (see Figure 23).

NOTE: The switchplate’s two DB9 connectors access the same port. Connecting to one disables the other.

- b. Connect the RF control cable (RJ22 to DB9-female) from the RJ22 jack on the back of the switchplate to the “RF Port” connector on the MCP.

- c. Connect the RF1 cable from the antenna to the “Satellite In” connector on the primary receiver. The primary receiver controls satellite selection.

NOTE: Any additional receiver(s) will be able to select channels carried on the satellite that is currently selected by the primary receiver.

- d. If you have a second receiver, connect the RF2 cable from the antenna to the “Satellite In” connector on the second receiver.
- e. If the system is equipped with a quad LNB, connect the RF3 and RF4 cables from the antenna to the “Satellite In” connectors on the third and fourth receivers, if applicable.

IMPORTANT!

Be sure all receivers are grounded. If the receiver has a 2-prong power plug, run a ground wire from the receiver’s chassis to a suitable ground point. If a potential exists between AC and DC grounds, connect the wire to the switchplate’s DC return instead.

NOTE: If you need to connect more than four receivers, install an active multiswitch that generates a 22 KHz tone (such as Spaun model SMS 5602 NF - KVH part #19-0413). Connect the multiswitch in accordance with the manufacturer’s instructions.

- f. Connect the receiver(s) to the television(s). Follow the steps in the receiver’s manual.

Figure 23: MCP and Receiver Wiring

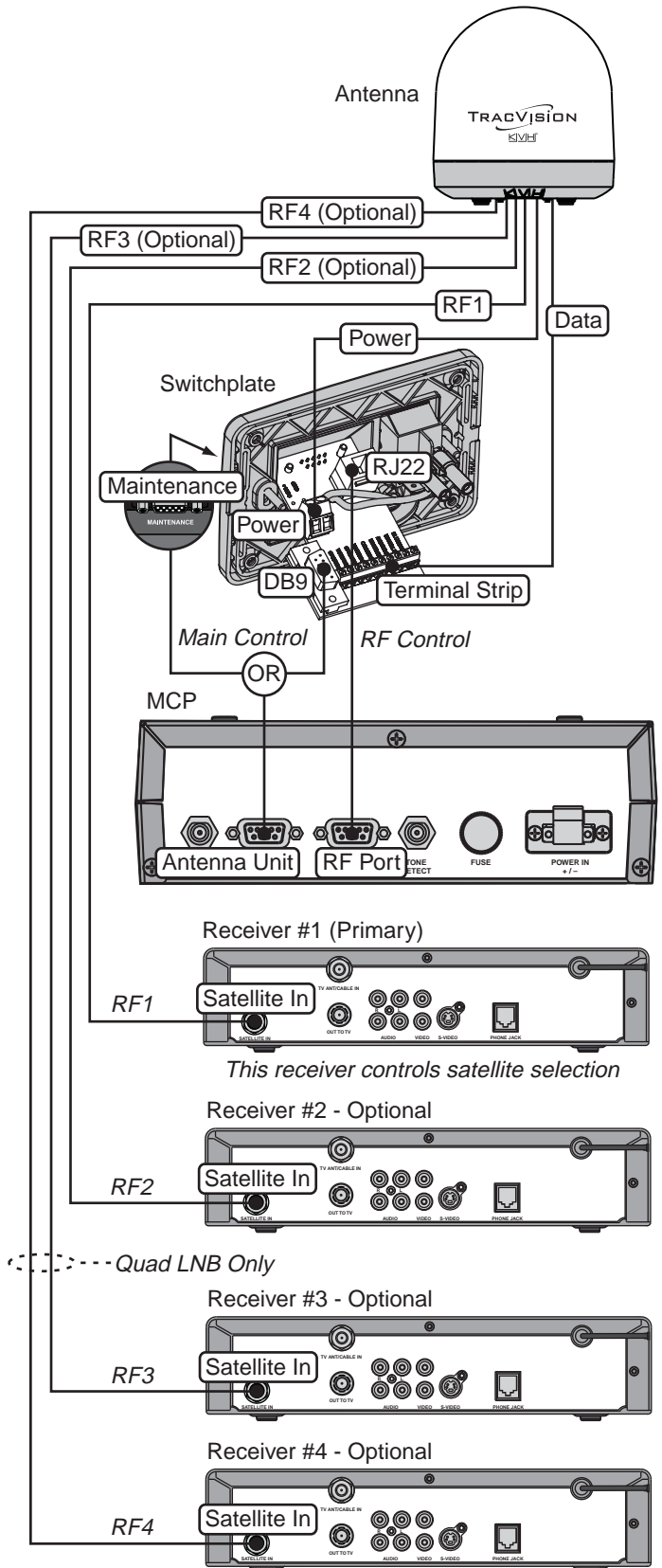

11 Connect Power

Follow these steps to connect power. The switchplate supplies power to both the antenna and the MCP.

- a. Before you begin, disconnect vessel power.

| | |
|---|----------------|
|  | CAUTION |
| <p>For your own safety, disconnect vessel power and make sure the circuit is dead before you connect any power wires.</p> | |

- b. Route a set of power wires from the switchplate's power output terminals to the MCP (for cable specifications, see Figure 2 on page 3). Connect the wires to the plastic power plug supplied in the kitpack (see Figure 24).

NOTE: You should now have two wires connected to each power output terminal on the switchplate: one set of wires to power the antenna and one set to power the MCP.

- c. Tighten the terminal screws on the switchplate to secure all wires in place.
- d. Plug the MCP power plug into the "Power In" jack on the MCP (see Figure 25). Secure in place with the retaining screws.
- e. Connect a power cable to 12 VDC (4 amps continuous) vessel power (for cable specifications, see Figure 2 on page 3). Route the other end to the switchplate.

| |
|--|
| <p>IMPORTANT!</p> <p>Power supplied to the antenna must not fall below 12 VDC or exceed 16 VDC.</p> |
|--|

- f. Detach the two terminal connectors from the back of the switchplate and crimp them onto the power cable's wires.
- g. Connect the power cable wires to the power (+) and ground (-) input terminals on the switchplate (see Figure 26).

Figure 24: MCP Power Plug

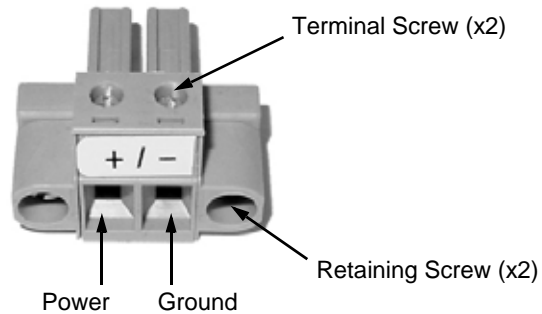

Figure 25: MCP Power Wiring

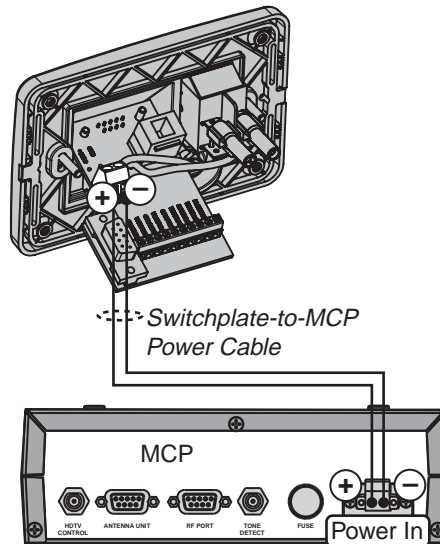
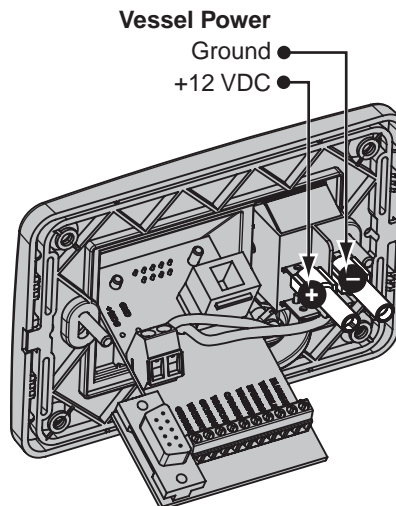

Figure 26: Switchplate Wiring - Vessel Power Cable



12 Mount the Switchplate & MCP

In Step 4, you prepared the mounting sites for the switchplate and MCP. Now follow these steps to mount them.

Switchplate

NOTE: As an alternative, the switchplate includes two additional mounting holes for installing within an electrical panel. If you chose this option, simply use two of the #6 screws to mount the switchplate to the panel.

- Align the four mounting holes in the switchplate with the holes in the mounting surface (see Figure 27).
- Mount the switchplate to the mounting surface using four #6 screws.
- Gently snap the front cover onto the switchplate to conceal the mounting screws.

Figure 27: Mounting the Switchplate

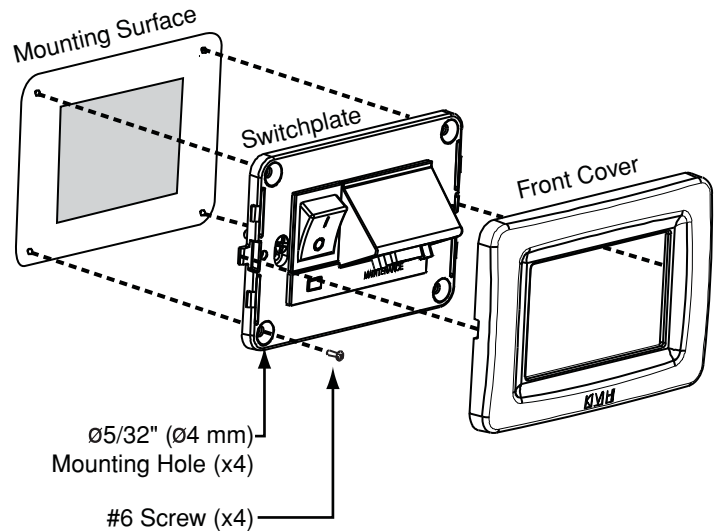

MCP - Velcro Mount Option

- Clean and dry the bottom of the MCP and the mounting surface (use a mild detergent).
- Peel the backing from the two supplied Velcro fabric squares and stick them to the bottom of the MCP (see Figure 28).
- Position the two Velcro hook disks onto the mounting surface. Drill screw holes for the disks and secure in place with #4-24 screws.
- Press the MCP firmly into place so that the fabric's loop material engages the hook disks.

Figure 28: Velcro Mounting the MCP to a Horizontal Surface

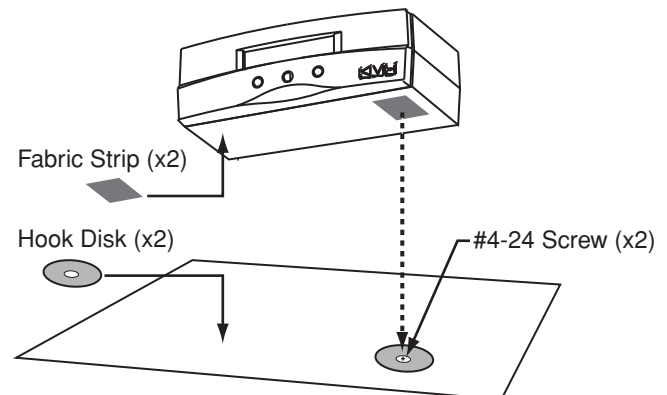

MCP- Flush Mount Option

- Make sure the flush mount bracket is attached to the MCP. If it is not attached, disconnect all of the cables from the MCP, attach the bracket as explained in Step 4 on page 6, then reconnect the cables.
- Insert the MCP and bracket assembly into the mounting hole and secure in place with four #8 screws and washers (see Figure 29).

Figure 29: Flush Mounting the MCP to a Vertical Surface

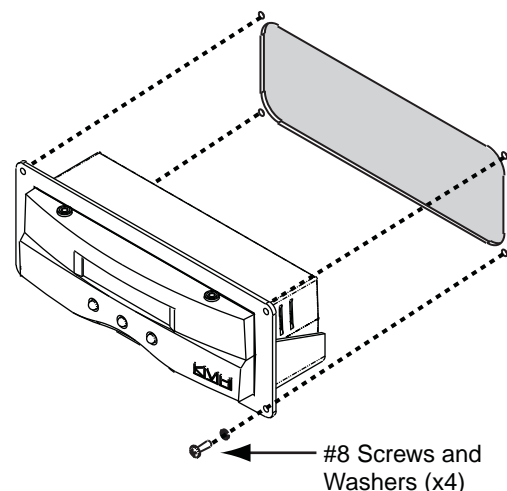

13 Turn On the System

Follow these steps to turn on the TracVision system.

- a. Ensure the antenna has a clear, unobstructed view of the sky so it can receive satellite signals.
- b. Apply power to the satellite TV receiver(s) and TV(s).
- c. Set the switchplate's power switch to the "on" position to apply power to the TracVision system (see Figure 30).
- d. Wait one minute for system startup. When the MCP display shows "Set up satellite(s)," proceed to the next step.

Figure 30: Switchplate Power Switch

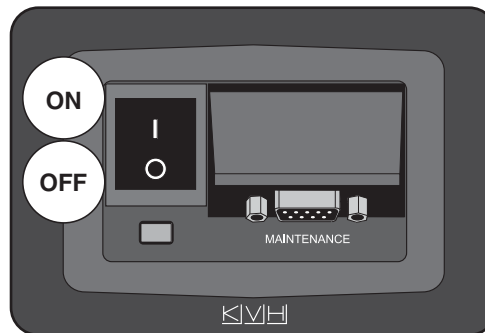

14 Choose an Operating Mode

Circular Systems Only

If you are installing a **circular** system, choose the appropriate operating mode for your customer's satellite TV service provider and satellite preferences (see Figure 31). You will select this mode in the next step.

DIRECTV

Dual-Sat:

Select this mode if you wish to receive programming from the 101 and 119 satellites for DIRECTV service.

Tri-Sat or Tri-Sat Pairs:

Do not use either of these modes for a new installation. The Tri-Sat Auto mode supports the Tri-Sat AutoSwitch; the Tri-Sat Pairs mode supports the HDTV Converter. These HDTV devices are no longer available.

DISH Network

DISH 1000/61 or DISH 1000/129:

Select one of these modes for DISH Network's three-satellite service (DISH 1000). Use the map in Figure 32 to help determine the appropriate DISH 1000 mode for your geographic area. Check with DISH Network for local channels availability.

DISH 500:

Select this mode if you wish to receive programming from the 119 and 110 satellites for DISH 500 service.

Bell TV (formerly ExpressVu)

Select the Bell TV service to receive Bell TV programming from the 91 and 82 satellites.

Custom

If none of the above modes meets your customer's needs, you may select any two satellites from the antenna's built-in library using the Custom service mode.

Figure 31: Satellites Tracked in Each Operating Mode

DIRECTV

| Mode | Satellites Tracked |
|--|--------------------|
| Dual-Sat | 101 and 119 |
| Tri-Sat or Tri-Sat Pairs <i>(Not used)</i> | 101, 110, and 119 |

DISH Network

| Mode | Satellites Tracked |
|----------------|--------------------|
| DISH 1000/61 | 119, 110, and 61 |
| DISH 1000/129* | 119, 110, and 129 |
| DISH 500 | 119 and 110 |

* Optional Master Receiver Selector (KVH part #72-0412) required for automatic satellite switching; multiswitch (KVH part #72-0310) required for manual switching; see Appendix A on page 31.

Bell TV

| Mode | Satellites Tracked |
|---------|--------------------|
| Bell TV | 91 and 82 |

Figure 32: Recommended Areas for DISH 1000 Satellites

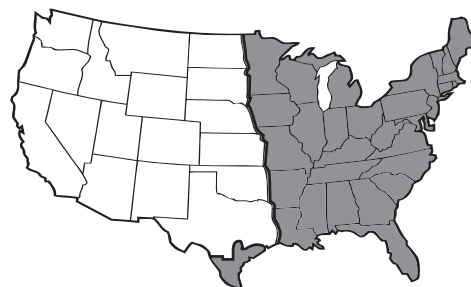

- = DISH 129 Satellite Recommended
- = DISH 61 Satellite Recommended

15 Select Satellites

Circular Systems - DIRECTV

Follow these steps and refer to the flowchart in Figure 33 to set up the system for a DIRECTV mode (see Step 14 on page 17 for a description of each mode).

- At "Set up satellite(s)," press the **YES** button on the MCP's front panel.
- At "Circular or Linear?," press **CIR**.
- At "Service=DIRECTV," press **YES**.
- At "Mode=Dual-Sat?," press **NEXT** until the display shows the desired DIRECTV mode. Then press **YES**.
- At "Set Sat Switch Type," press **AUTO** for automatic satellite switching or **MANUAL** for manual switching. Manual switching is only required if a multiswitch is installed.
- At "Set Lat/Long?," press **YES**.

TIP: You can determine your approximate latitude and longitude in North America from the position grids provided in Appendix C on page 34.

- At "Latitude," use the - and + buttons to set each digit of the vessel's latitude. Press **Enter** to accept each digit.
- At "Longitude," set the vessel's longitude.

Figure 33: DIRECTV Satellite Selection Menus on MCP

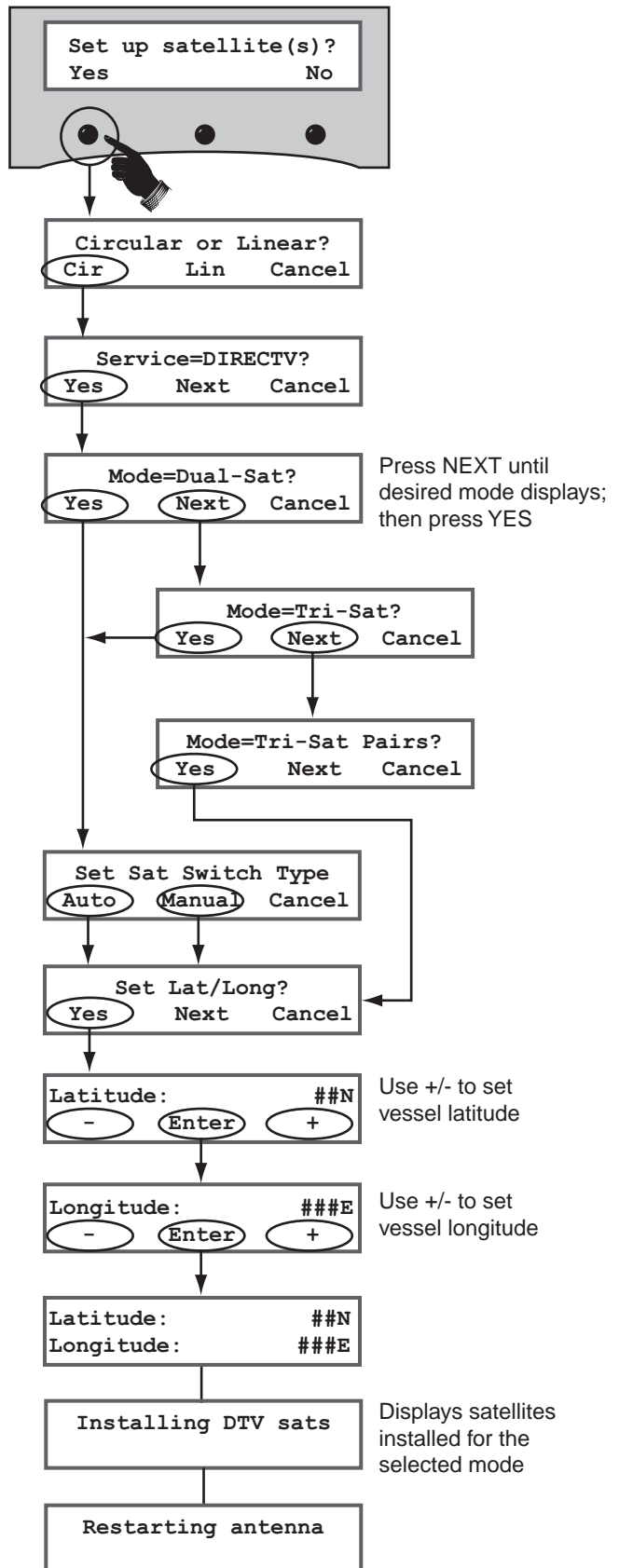

15 Select Satellites

Follow these steps and refer to the flowchart in Figure 34 to set up the system for a DISH Network mode (see Step 14 on page 17 for a description of each mode).

- At “Set up satellite(s),” press the **YES** button on the MCP’s front panel.
- At “Circular or Linear?,” press **CIR**.
- At “Service=DIRECTV,” press **NEXT** until the display shows “Service=DISH.” Then press **YES**.
- At “Mode=DISH 1000/61?,” press **NEXT** until the display shows the desired DISH mode. Then press **YES**.
- At “Set Sat Switch Type,” press **AUTO** for automatic satellite switching or **MANUAL** for manual switching. Manual switching is only required if a multiswitch is installed.
- At “Set Lat/Long?,” press **YES**.

TIP: You can determine your approximate latitude and longitude in North America from the position grids provided in Appendix C on page 34.

- At “Latitude,” use the - and + buttons to set each digit of the vessel’s latitude. Press **Enter** to accept each digit.
- At “Longitude,” set the vessel’s longitude.

Circular Systems - DISH

Figure 34: DISH Satellite Selection Menus on MCP

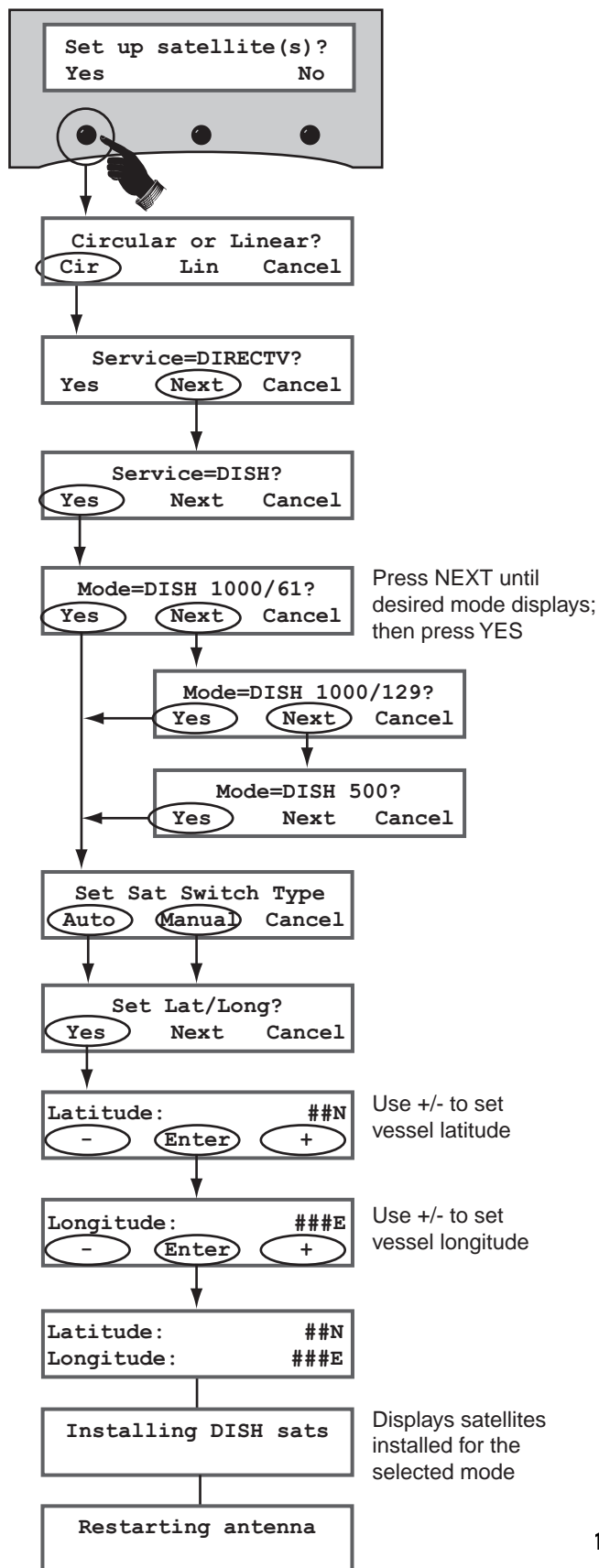

15 Select Satellites

Circular Systems - Bell TV

Follow these steps and refer to the flowchart in Figure 35 to set up the system for Bell TV (formerly ExpressVu). The antenna will track Bell TV's 91 and 82 satellites.

- At "Set up satellite(s)," press the **YES** button on the MCP's front panel.
- At "Circular or Linear?," press **CIR**.
- At "Service=DIRECTV," press **NEXT** until the display shows "Service=ExpressVu." Then press **YES**.
- At "Set Sat Switch Type," press **AUTO** for automatic satellite switching or **MANUAL** for manual switching. Manual switching is only required if a multiswitch is installed.
- At "Set Lat/Long?," press **YES**.

TIP: You can determine your approximate latitude and longitude in North America from the position grids provided in Appendix C on page 34.

- At "Latitude," use the - and + buttons to set each digit of the vessel's latitude. Press **Enter** to accept each digit.
- At "Longitude," set the vessel's longitude.

Figure 35: Bell TV Satellite Selection Menus on MCP

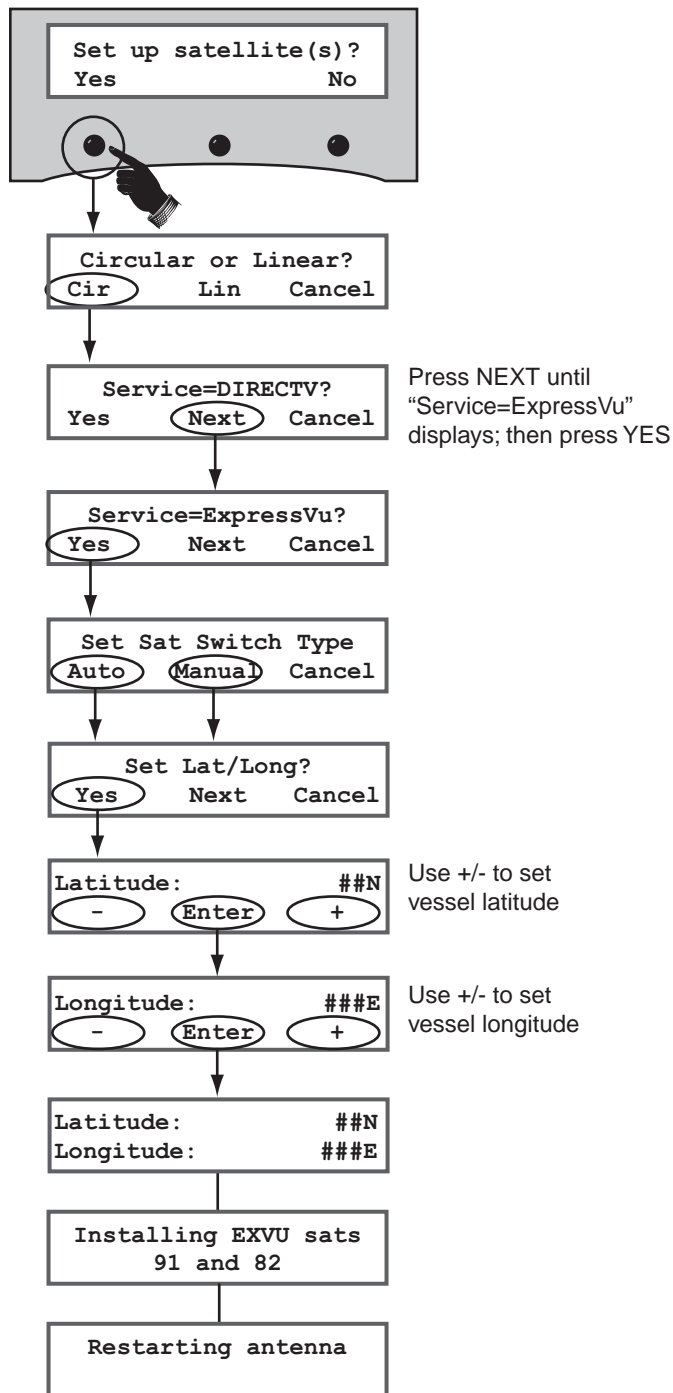

15 Select Satellites

Circular Systems - Custom

Follow these steps and refer to the flowchart in Figure 36 to set up the system for a custom pair of satellites from the antenna's library.

- At "Set up satellite(s)," press the **YES** button on the MCP's front panel.
- At "Circular or Linear," press **CIR**.
- At "Service=DIRECTV," press **NEXT** until the display shows "Service=Custom." Then press **YES**.
- At "Install A <SAT NAME>," press **NEXT** until the display shows the first (primary) satellite you want to select. Then press **YES**. (See Appendix B on page 33 for a list of available satellites.)

NOTE: If you don't find the satellite you want, you can set up user-defined satellites. Refer to the associated Application Note on the KVH Partner Portal (KVH-authorized technicians only).

- Repeat Step d to select the second satellite. If you want to set up the antenna to track just one satellite, select "None" instead.
- At "Set Lat/Long?," press **YES**.

TIP: You can determine your approximate latitude and longitude in North America from the position grids provided in Appendix C on page 34.

- At "Latitude," use the - and + buttons to set each digit of the vessel's latitude. Press **Enter** to accept each digit.
- At "Longitude," set the vessel's longitude.

NOTE: The customer will need to use the buttons on the MCP's front panel to manually switch between satellites (see the User's Guide for details).

Figure 36: Custom Pair Satellite Selection Menus on MCP

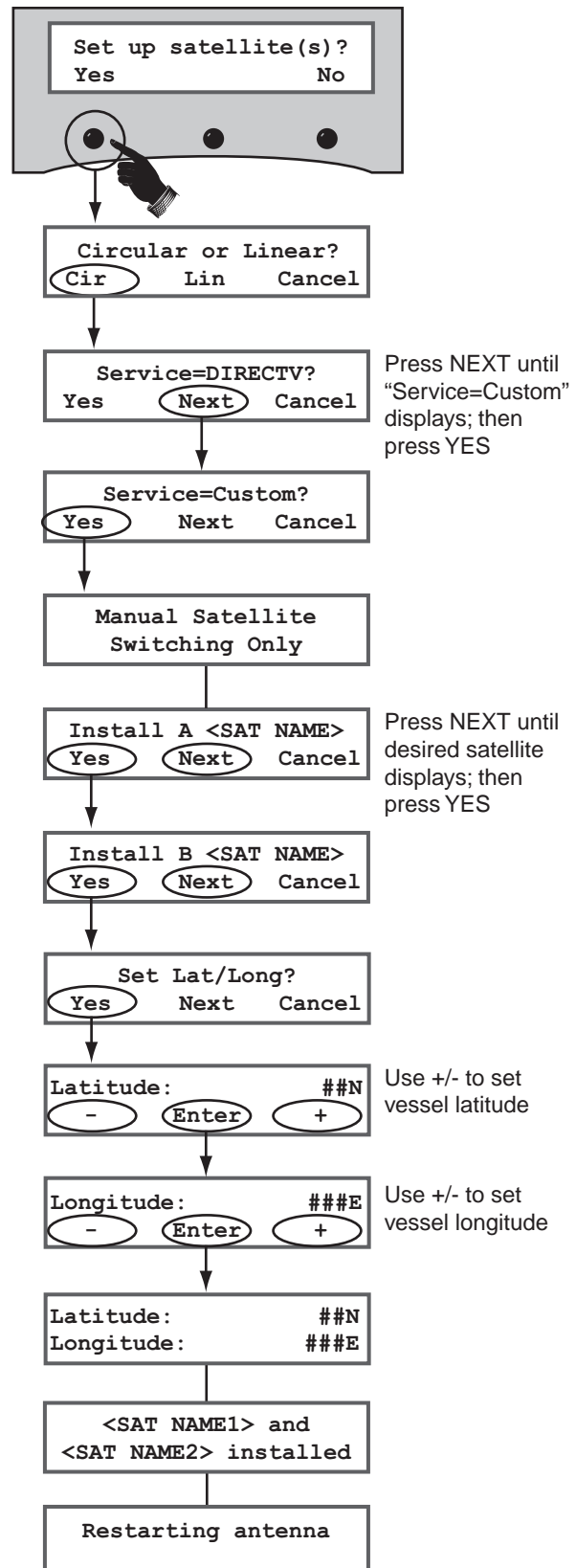

15 Select Satellites

Linear Systems - Tri-Sat

Follow these steps and refer to the flowchart in Figure 37 to set up the system for one of the following European Trisat groups:

| Group | Satellites | | |
|-------------|------------|--------|---------|
| | Sat. A | Sat. B | Sat. C |
| Europe WB | HotbirdWB | Astra1 | Astra2S |
| Europe | Hotbird | Astra1 | Astra2S |
| Scandinavia | HotbirdWB | Sirius | Thor |

- At "Set up satellite(s)," press the **YES** button on the MCP's front panel.
- At "Circular or Linear?," press **LIN**.
- At "Trisat Mode?," press **YES**.
- At "Install Europe WB?," press **NEXT** until the display shows the Tri-Sat group you want to select. Then press **YES**.
- At "Set Sat Switch Type," press **AUTO** for automatic satellite switching (*recommended*) or **MANUAL** for manual switching.
- At "Set Lat/Long?," press **YES**.

TIP: You can determine approximate latitude and longitude in Europe from the position grids provided in Appendix C on page 34.

- At "Latitude," use the - and + buttons to set each digit of the vessel's latitude. Press **Enter** to accept each digit.
- At "Longitude," set the vessel's longitude.
- After the antenna restarts, at "Skew Angle," note the reported skew angle for future reference. Then press **OK**. You will set the LNB to this skew angle later.
- Set up the receiver(s) for the same satellites, and in the same order, as the antenna:

| Antenna | Receiver | DiSEqC |
|---------|--------------------|----------|
| Sat. A | Alternative 1 or A | DiSEqC 1 |
| Sat. B | Alternative 2 or B | DiSEqC 2 |
| Sat. C | Alternative 3 or C | DiSEqC 3 |

Figure 37: European Trisat Group Selection Menus on MCP

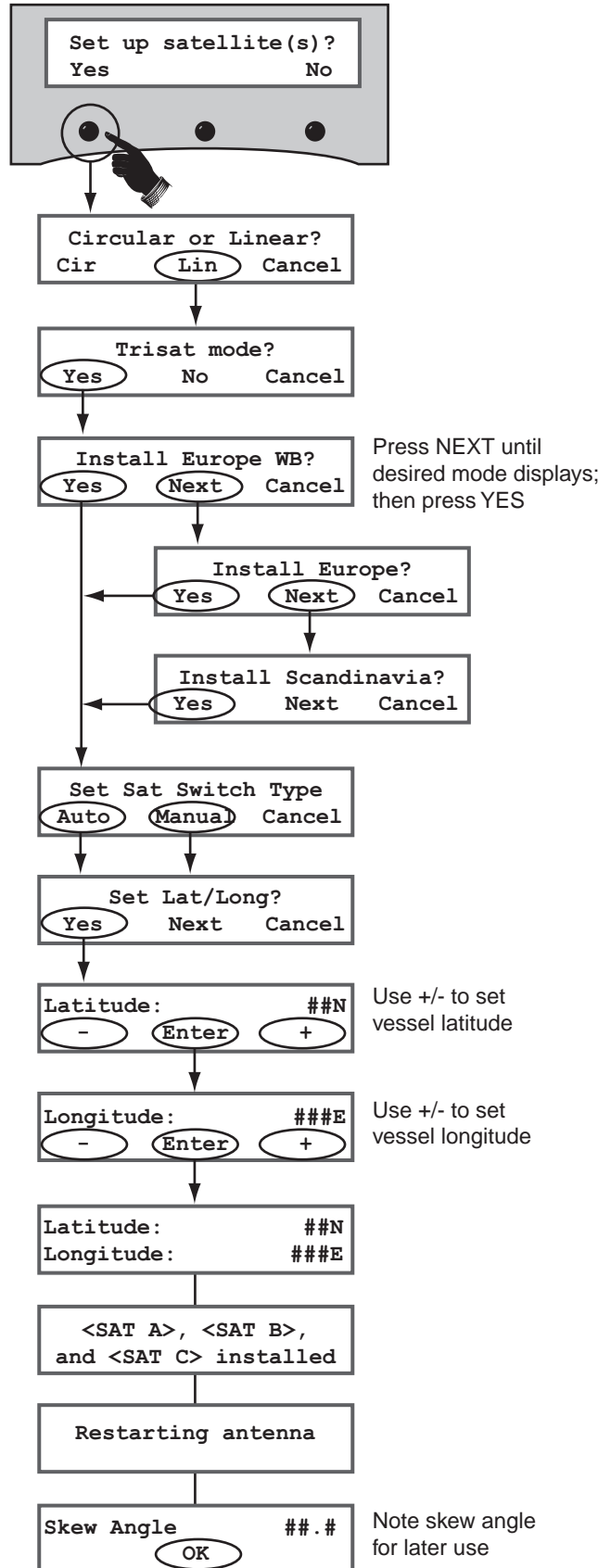

15 Select Satellites

Linear Systems - Custom

Follow these steps and refer to the flowchart in Figure 38 to set up the system for a custom pair of satellites from the antenna's library.

- At "Set up satellite(s)," press the **YES** button on the MCP's front panel.
- At "Circular or Linear," press **LIN**.
- At "Trisat Mode?," press **NO**.
- At "Install A <SAT NAME>," press **NEXT** until the display shows the first (primary) satellite you want to select. Then press **YES**. (See Appendix B on page 33 for a list of available satellites.)

NOTE: If you don't find the satellite you want, you can set up user-defined satellites. Refer to the associated Application Note on the KVH Partner Portal (KVH-authorized technicians only).

- Repeat Step d to select the second satellite. If you want to set up the antenna to track just one satellite, select "None" instead.
- At "Set Sat Switch Type," press **AUTO** for automatic satellite switching (*recommended*) or **MANUAL** for manual switching.
- At "Set Lat/Long?," press **YES**.

TIP: You can determine approximate latitude and longitude in Europe from the position grids provided in Appendix C on page 34.

- At "Latitude," use the - and + buttons to set each digit of the vessel's latitude. Press **Enter** to accept each digit.
- At "Longitude," set the vessel's longitude.
- After the antenna restarts, at "Skew Angle," note the reported skew angle for future reference. Then press **OK**. You will set the LNB to this skew angle later.
- Set up the receiver(s) for the same satellites, and in the same order, that you set them up in the antenna:

| Antenna | Receiver | DiSEqC |
|---------|--------------------|----------|
| Sat. A | Alternative 1 or A | DiSEqC 1 |
| Sat. B | Alternative 2 or B | DiSEqC 2 |

Figure 38: Custom Pair Satellite Selection Menus on MCP

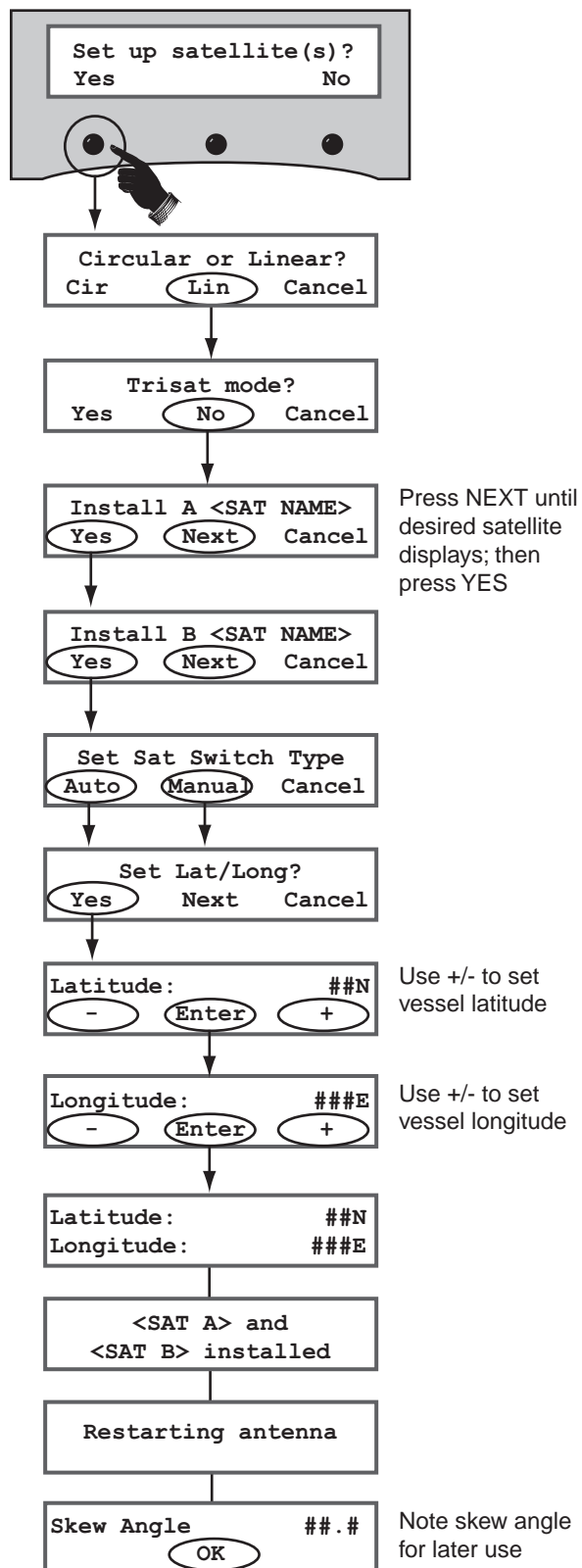

16 Set the LNB Skew Angle

Linear Systems Only

This step does not apply to linear systems with Auto Skew capability.

Follow these steps to set the antenna's linear LNB to the skew angle you noted earlier.

- a. Turn off and unplug the receiver(s) and disconnect antenna power at the switchplate.



CAUTION

Disconnect power from the antenna and the receivers before you adjust the LNB. The antenna's moving parts can cause injury.

- b. Remove the antenna's radome, if you reinstalled it earlier in Step 8.
- c. Locate the LNB on the back of the antenna's reflector (see Figure 39).
- d. Using a 2 mm allen hex key, loosen the two M4 socket set screws on the LNB choke feed. These screws secure the LNB in place.
- e. Adjust the LNB clockwise or counter-clockwise until the skew arrow on the LNB points to the skew angle you noted earlier (see Figure 40).

IMPORTANT!

Be sure to keep the LNB fully inserted into the choke feed to ensure optimum performance.

- f. Tighten the two M4 socket set screws to secure the LNB in place. Apply 9 in-lbs (1 Nm) of torque, if possible.
- g. Reinstall the radome (as explained in Steps 8d-e on page 10).

Figure 39: Set Screws Securing the LNB to the Reflector

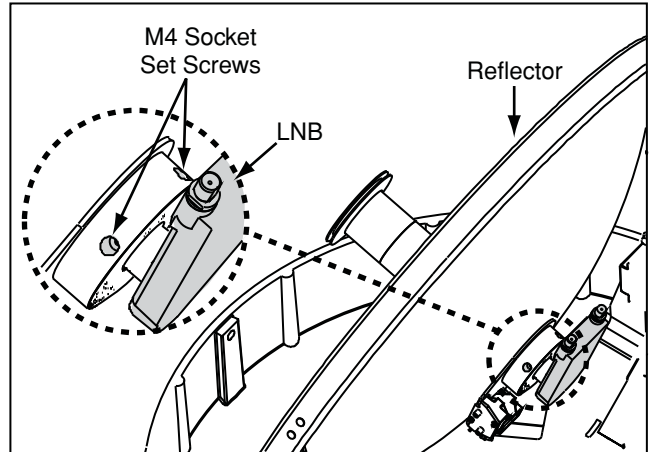
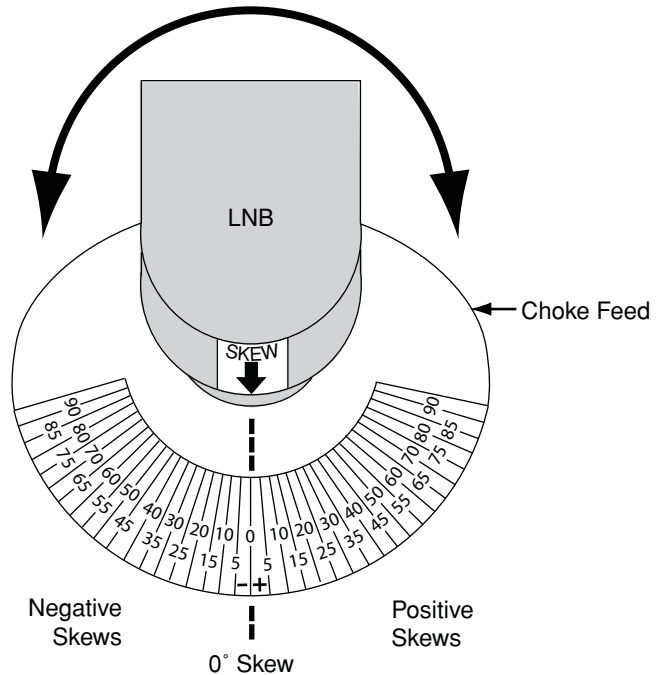

Figure 40: LNB Skew Angle Adjustment



17 Run a Check Switch Test

If you set up the system for **DISH Network** or **Bell TV** (formerly ExpressVu), follow these steps to run the receiver's Check Switch test as required.

Primary Receiver

Follow these steps to run a Check Switch test on the primary receiver, which is connected to the antenna's "RF1" cable. This receiver will control satellite selection.

- Make sure the vessel is docked in calm water in a blockage-free area. Ensure the antenna has an unobstructed view of the sky.
- Apply power to the TV and receiver. (If the antenna is turned off, turn it back on and wait until the MCP shows "Tracking.")
- Using the receiver's remote, go to the "Point Dish/Signal Strength" screen (press MENU, 6, 1, 1 on most models).
- Choose **Check Switch**, then press SELECT.
- Choose **Check** or **Test**, then press SELECT.

IMPORTANT!

Please be patient. The Check Switch test takes approximately 15 minutes to complete. Disregard any messages on the TV; they do not correctly indicate the status of the test.

- When the MCP no longer shows "Check Switch Running," refer to the tables in Figure 41 and verify the values displayed on your TV match those required for your selected service. **If your values do not match:** Turn off the antenna, then turn it back on and repeat Steps c-e. When the MCP shows "Please Run Check Switch," repeat Steps c-e again to run a second Check Switch.
- Exit the menu and allow the receiver to download the program guide.

DISH Network or Bell TV Only

Figure 41: Expected Check Switch Results Displayed on TV

DISH 1000/129 Results

| Port | 1 | 2 | 3 |
|-----------|--------------------|-----|-----|
| Satellite | 119 | 110 | 129 |
| Trans | OK | OK | OK |
| Status | Reception Verified | | |
| Switch | SW64 | | |

DISH 1000/61 Results

| Port | 1 | 2 | 3 |
|-----------|--------------------|-----|----|
| Satellite | 119 | 110 | 61 |
| Trans | OK | OK | OK |
| Status | Reception Verified | | |
| Switch | SW64 | | |

DISH 500 Results

| Input | 1 | 1 | 2 | 2 |
|-----------|--------------------|------|-----|------|
| Satellite | 119 | 119 | 110 | 110 |
| Polarity | Odd | Even | Odd | Even |
| Status | Reception Verified | | | |
| Switch | SW42 | | | |

Bell TV Results*

| Input | 1 | 1 | 2 | 2 |
|-----------|--------------------|------|-----|------|
| Satellite | 91 | 91 | 82 | 82 |
| Polarity | Odd | Even | Odd | Even |
| Status | Reception Verified | | | |
| Switch | SW21 | | | |

* If you installed just one Bell TV satellite, the TV will show an error message instead. This is normal.

Additional Receiver(s)

If you connected multiple receivers, follow these steps to run a Check Switch test on each additional receiver (one at a time), **unless it is a preconfigured DISH receiver**. *When you are done, reconnect the receivers as before.*

- a. Temporarily disconnect the primary receiver from the antenna's "RF1" cable.
- b. Connect the additional receiver to the antenna's "RF1" cable.
- c. Perform Steps a-e on page 25 to run a single Check Switch test on the receiver.
- d. Wait 15 minutes, then verify the values on the TV match the values shown in Figure 41 on page 25. If your values do not match, try running another Check Switch test.

18 Educate the Customer

Before you leave the vessel, test the system to verify the antenna works properly. Then give the Customer Welcome Kit to the customer and be sure the customer understands the following:

- The receiver(s) must be activated before it can decode satellite TV signals. Refer to Figure 42 for activation details for North America.
- Keep the radome installed on the antenna at all times. The radome protects the antenna's moving parts from wind, rain, and debris.

| | |
|--|----------------|
|  | WARNING |
| It is dangerous to watch TV while piloting a vessel. While under way, the system is intended for passenger entertainment only. | |

- The antenna must have a clear view of the sky to receive satellite TV. Common causes of blockage include trees, buildings, bridges, and onboard equipment (see Figure 43). Heavy rain or snow may also temporarily interrupt reception.
- Clean the antenna regularly. Dirt buildup on the radome can affect reception.
- **DISH 1000 modes only:** You might need to change the operating mode when traveling between regions (see “Choose an Operating Mode” on page 17).
- **Linear only:** If the system does not have Auto Skew capability, you might need to adjust the skew angle of your antenna's LNB when you travel to other geographic locations, (see “Set the LNB Skew Angle” on page 24).
- The vessel must be located within the selected satellite's coverage area to receive its satellite TV signals. To view satellite coverage maps, visit www.kvh.com/footprint.
- Please register the system with KVH. The registration process is quick, easy, online, and ensures the best possible service from KVH. Visit www.kvh.com/register or refer to the Product Registration Form for details.
- Refer to the *User's Guide* for operation and troubleshooting information.

Figure 42: North American Receiver Activation Information

| Service: | Call to Activate: |
|--------------|--|
| DIRECTV | 1-866-551-8004 (24 hours, 7 days a week) |
| DISH Network | 1-866-399-8509 (Mon.-Fri., 8:30am - 5pm ET) |
| Bell TV | 1-888-759-3474 (SKY-DISH) (24 hours, 7 days a week) |

Figure 43: Example of Satellite Blockage

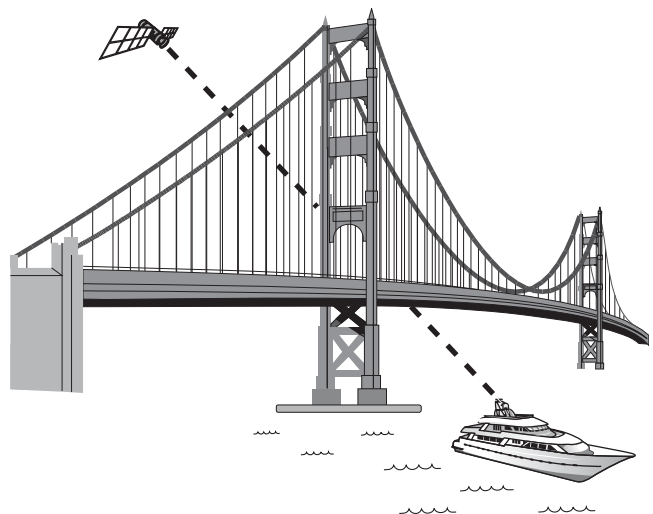

Appendices

This section provides supplemental instructions for wiring multiple receivers. It also provides a list of available satellites, system wiring diagrams, and mounting templates for the belowdecks equipment.

Contents

| | |
|---------------------------------------|----|
| A. Wiring 3+ Receivers | 31 |
| B. Satellite Library..... | 33 |
| C. Position Grids..... | 34 |
| D. Basic System Wiring Diagram | 35 |
| E. Switchplate Mounting Template..... | 37 |
| F. MCP Flush Mounting Template..... | 39 |

A Wiring 3+ Receivers

Circular Systems

If you need to connect three or more receivers, or you set up the system for DISH Network's 129 satellite (one or more receivers), install an active (powered) multiswitch or Master Receiver Selector between the grounding block and the receivers, as shown in Figure 44.

NOTE: If you need to connect more than four receivers, please contact KVH Technical Support.

Active Multiswitch

The optional Eagle Aspen multiswitch with AC/DC power supply (KVH part #72-0310) allows you to connect up to four receivers to the TracVision system. However, since a multiswitch interrupts satellite switching communications between the receiver and the antenna, you will need to manually switch between your selected satellites using the buttons on the MCP's front panel (see the *User's Guide* for details).

Master Receiver Selector

The optional KVH Master Receiver Selector (KVH part #72-0412) is an enhanced multiswitch that provides the following capabilities:

- Automatic satellite switching in any operating mode, including DISH 1000/129.
- Support for multiple receivers.
- Capability for the user to select, at any time, which receiver controls satellite selection. Simply turn the knob!

Figure 44: Wiring Up to 4 Receivers

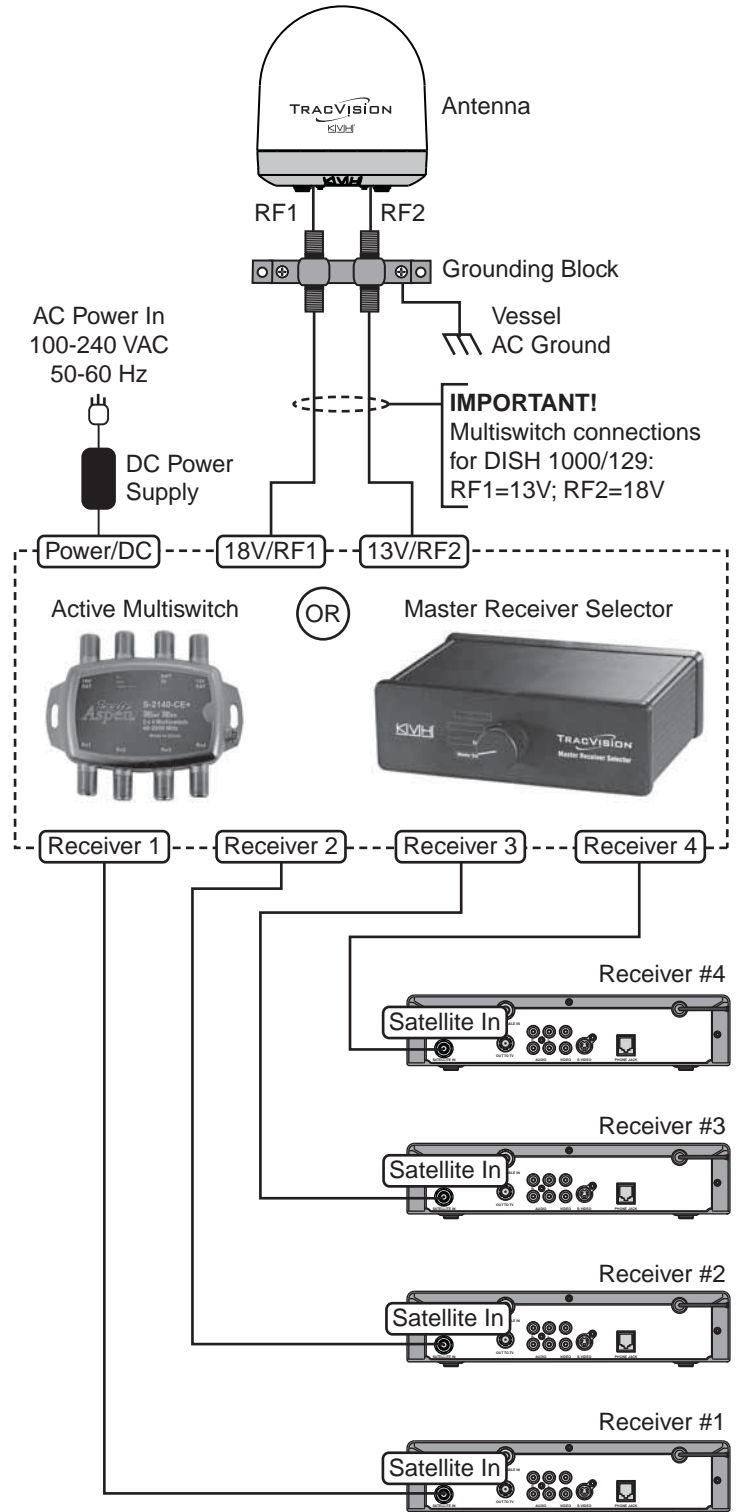

A Wiring 3+ Receivers

Sky Mexico Systems

To connect three or more receivers to a system configured for **Sky Mexico**, follow these steps to install a Spaun model SMS 5602 NF multiswitch (KVH part #19-0413) between the grounding block and the receivers, as shown in Figure 45.

1. Connect an RF cable from the “RF1” connector on the grounding block to the “H/High” (Horizontal High) connector on the multiswitch.
2. Connect an RF cable from the “RF2” connector on the grounding block to the “V/High” (Vertical High) connector on the multiswitch.
3. Set the multiswitch’s LNB knob to “22 KHz.” *At this setting, the multiswitch will provide a constant 22 KHz tone to the antenna’s LNB.*
4. Connect the receivers to the individual outputs of the multiswitch.
5. Connect the receivers to the customer’s TVs.

Figure 45: Multiswitch Wiring - Sky Mexico

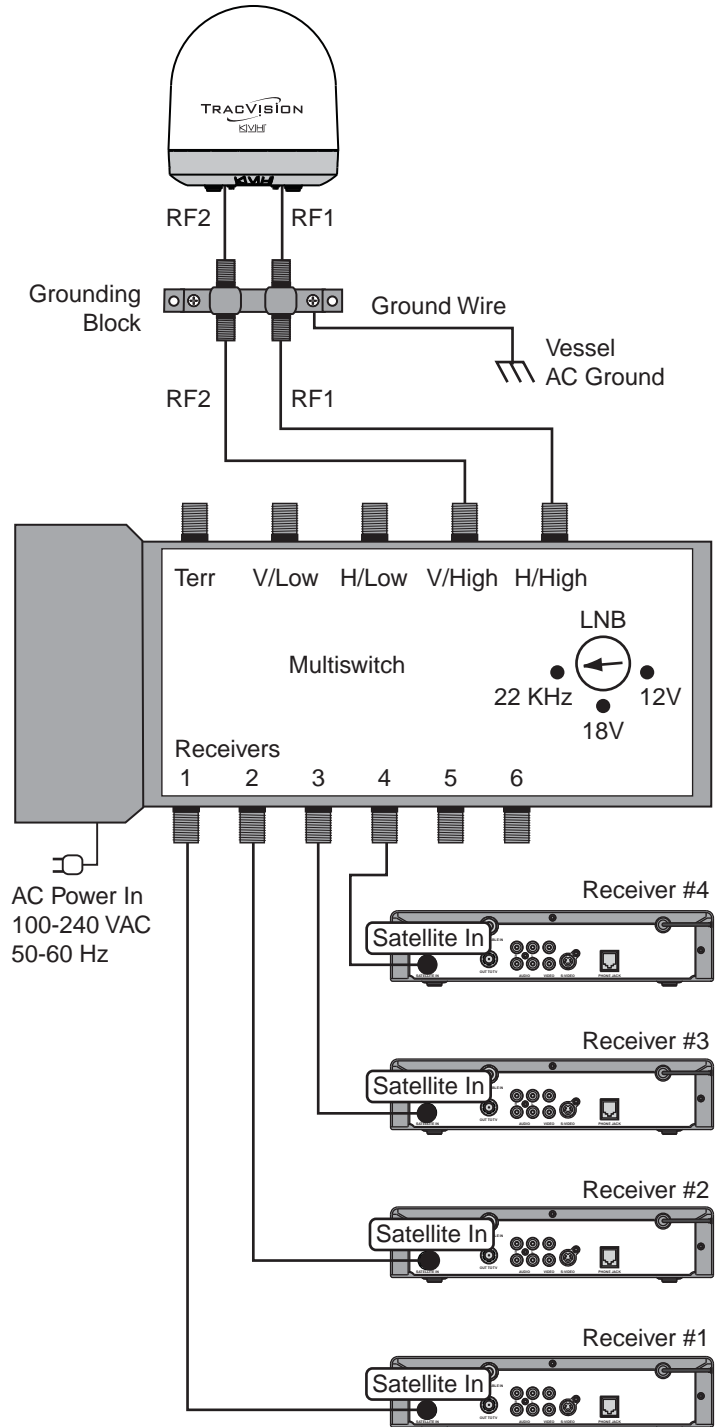

B Satellite Library

The TracVision antenna can track a variety of DVB-compatible and DSS (DIRECTV) satellites. Most popular satellites are programmed in the antenna's library (see the tables below).

North America

Circular LNB Required

| Satellite, Longitude | Name in Library |
|------------------------|-----------------|
| DIRECTV, 72°W | DSS_72 |
| DIRECTV, 101°W | DSS_101 |
| DIRECTV, 110°W* | DSS_110 |
| DIRECTV, 119°W | DSS_119 |
| EchoStar, 61°W | ECHO_61 |
| EchoStar, 110°W | ECHO_110 |
| EchoStar, 119°W | ECHO_119 |
| EchoStar/Ciel 2, 129°W | ECHO_129 |
| Bell TV, 82°W | EXPRESSVU |
| Bell TV, 91°W | EXPRESSTV |

* DIRECTV HD not supported.

Asia

Circular LNB Required

| Satellite, Longitude | Name in Library |
|----------------------|-----------------|
| Asiasat 4, 122.2°E | ASIASAT |
| Sinosat 1, 110.5°E* | SINOSAT |

* Special LNB required. Call KVH at 1-401-847-3327.

Latin America

Galaxy Circular LNB Required

| Satellite, Longitude | Name in Library |
|----------------------|-----------------|
| Galaxy 3C, 95°W | GALAXY3CN |

Europe

Linear LNB Required

| Satellite, Longitude | Name in Library |
|-----------------------|-----------------|
| Astra 1, 19.2°E | ASTRA1 |
| Astra 2N, 28.2°E | ASTRA2N |
| Astra 2S, 28.2°E | ASTRA2S |
| Hispasat, 30.0°W | HISPASAT |
| Hotbird, 13.0°E | HOTBIRD |
| Hotbird WB, 13.0°E | HOTBIRDWB |
| Astra (Sirius), 5.0°E | SIRIUS |
| Thor, 0.8°W | THOR |
| Arabsat/Badr 4, 26°E | ARABSAT |
| Nilesat, 7°W | NILESAT |
| Turksat 1C, 42°E | TURKSAT1C |
| Eutelsat W3A, 7°E | EUTEL_W3A |

Mexico

Linear LNB Required

| Satellite, Longitude | Name in Library |
|------------------------|-----------------|
| PAS 9/Intelsat 9, 58°W | PAS_9 |

Australia & New Zealand

Linear LNB Required

| Satellite, Longitude | Name in Library |
|----------------------|-----------------|
| Optus D1, 160°E | OPTUS_D1 |
| Optus C1, 156°E | OPTUS_C1 |

C Position Grids

If the vessel is located in Europe or North America, you may use the appropriate grid and table below to determine your approximate latitude and longitude.

Europe

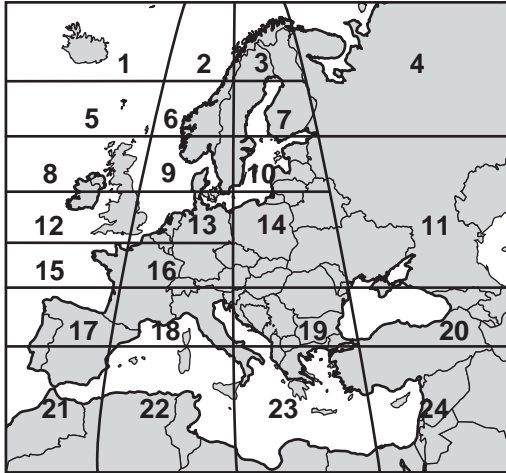

| Grid # | Latitude | Longitude |
|--------|----------|-----------|
| 1 | 67° N | 7° W |
| 2 | 67° N | 7° E |
| 3 | 67° N | 22° E |
| 4 | 65° N | 45° E |
| 5 | 63° N | 7° W |
| 6 | 63° N | 7° E |
| 7 | 63° N | 22° E |
| 8 | 57° N | 7° W |
| 9 | 57° N | 7° E |
| 10 | 57° N | 22° E |
| 11 | 55° N | 40° E |
| 12 | 53° N | 7° W |
| 13 | 53° N | 7° E |
| 14 | 50° N | 22° E |
| 15 | 47° N | 7° W |
| 16 | 47° N | 7° E |
| 17 | 43° N | 7° W |
| 18 | 43° N | 7° E |
| 19 | 43° N | 22° E |
| 20 | 43° N | 37° E |
| 21 | 36° N | 7° W |
| 22 | 36° N | 7° E |
| 23 | 36° N | 22° E |
| 24 | 36° N | 37° E |

North America

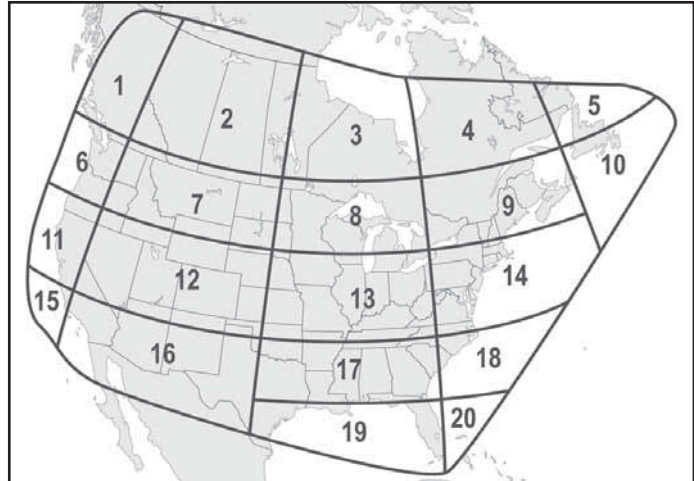

| Grid # | Latitude | Longitude |
|--------|----------|-----------|
| 1 | 55° N | 125° W |
| 2 | 55° N | 110° W |
| 3 | 55° N | 90° W |
| 4 | 55° N | 70° W |
| 5 | 55° N | 55° W |
| 6 | 45° N | 125° W |
| 7 | 45° N | 110° W |
| 8 | 45° N | 90° W |
| 9 | 45° N | 70° W |
| 10 | 45° N | 50° W |
| 11 | 40° N | 125° W |
| 12 | 40° N | 110° W |
| 13 | 40° N | 90° W |
| 14 | 40° N | 70° W |
| 15 | 32° N | 125° W |
| 16 | 32° N | 110° W |
| 17 | 32° N | 90° W |
| 18 | 32° N | 75° W |
| 19 | 27° N | 83° W |
| 20 | 27° N | 78° W |

D Basic System Wiring Diagram

Circular and Sky Mexico

This wiring diagram shows a basic circular or Sky Mexico system configuration.

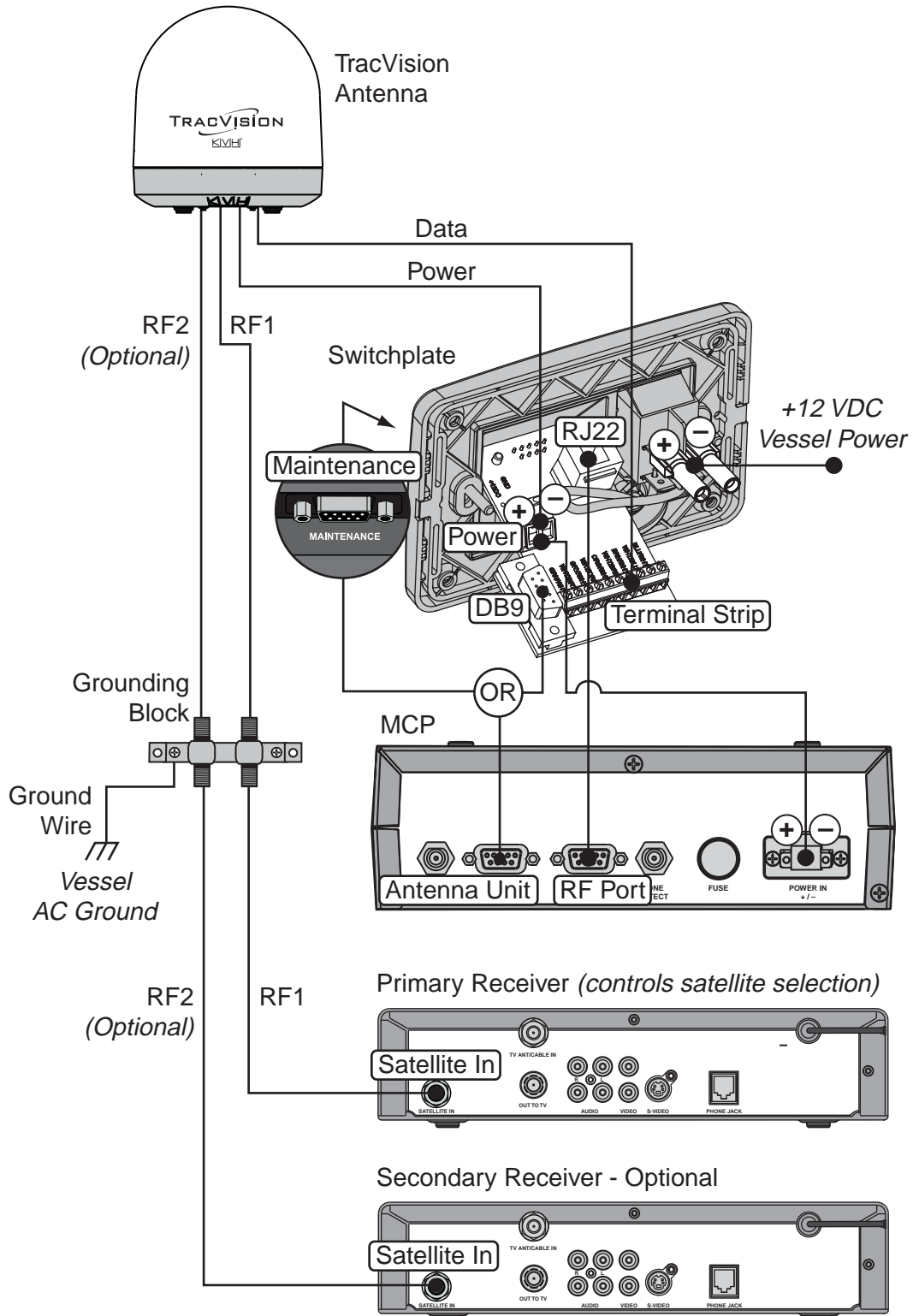

D Basic System Wiring Diagram

Linear Systems

This wiring diagram shows a basic linear system configuration.

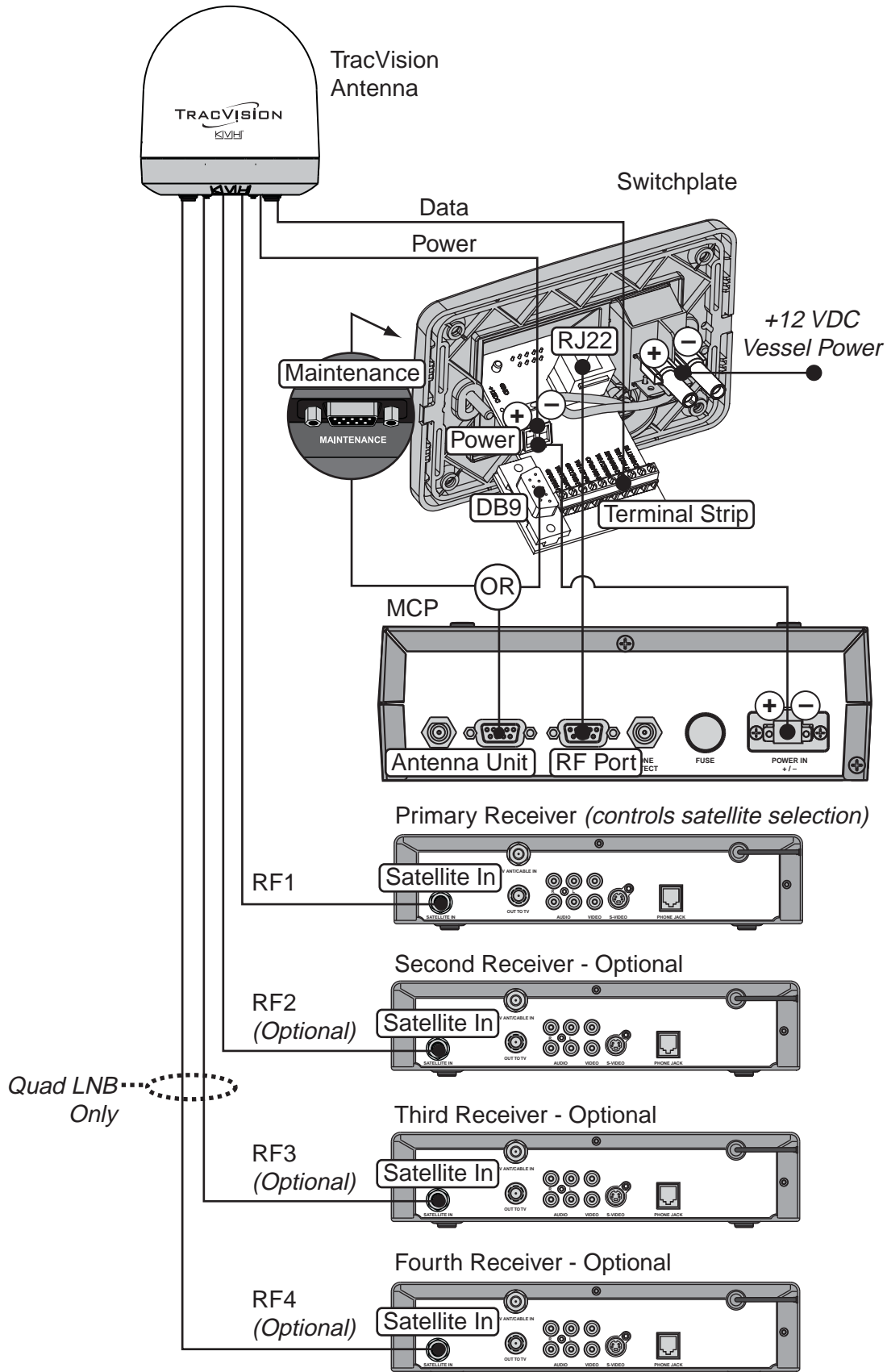

Switchplate Mounting Template

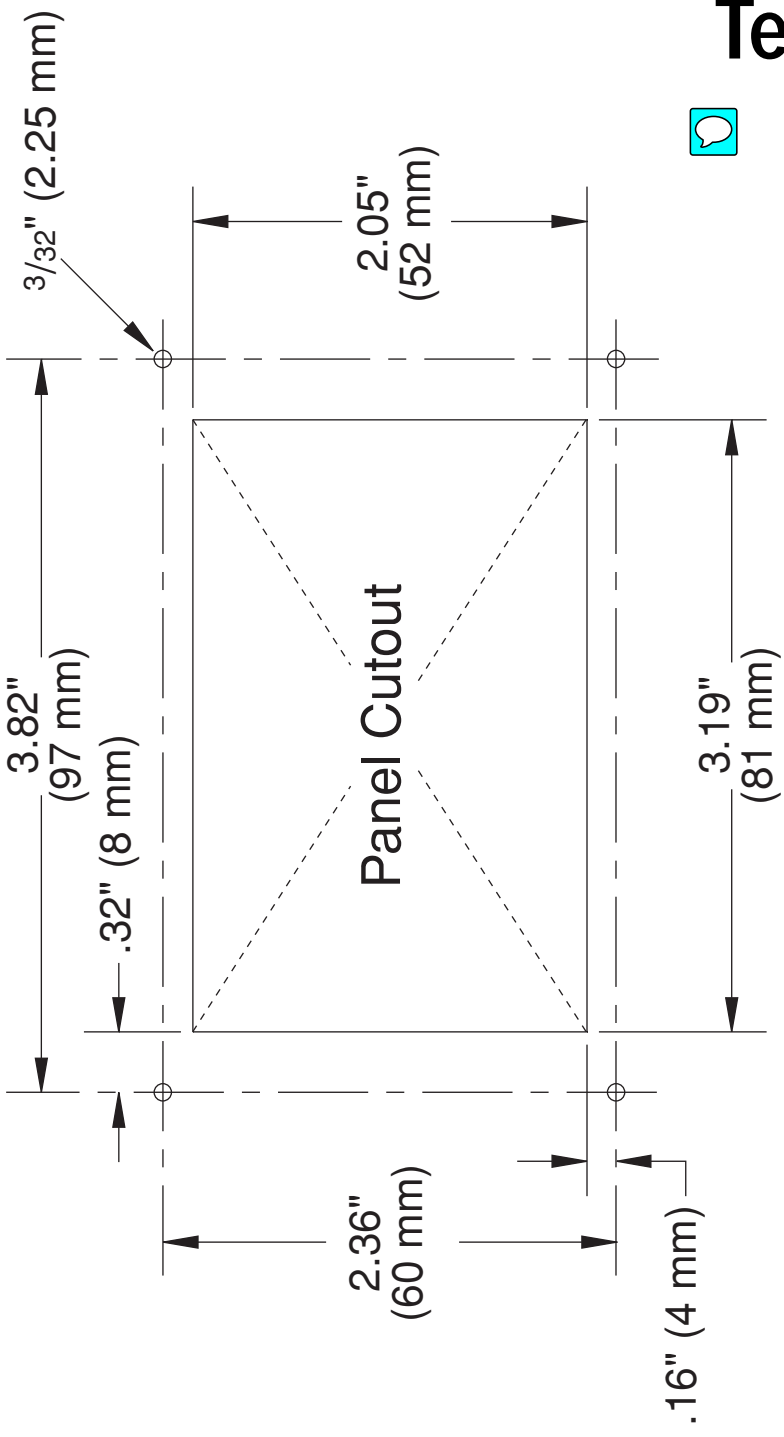

MCP Flush Mounting Template

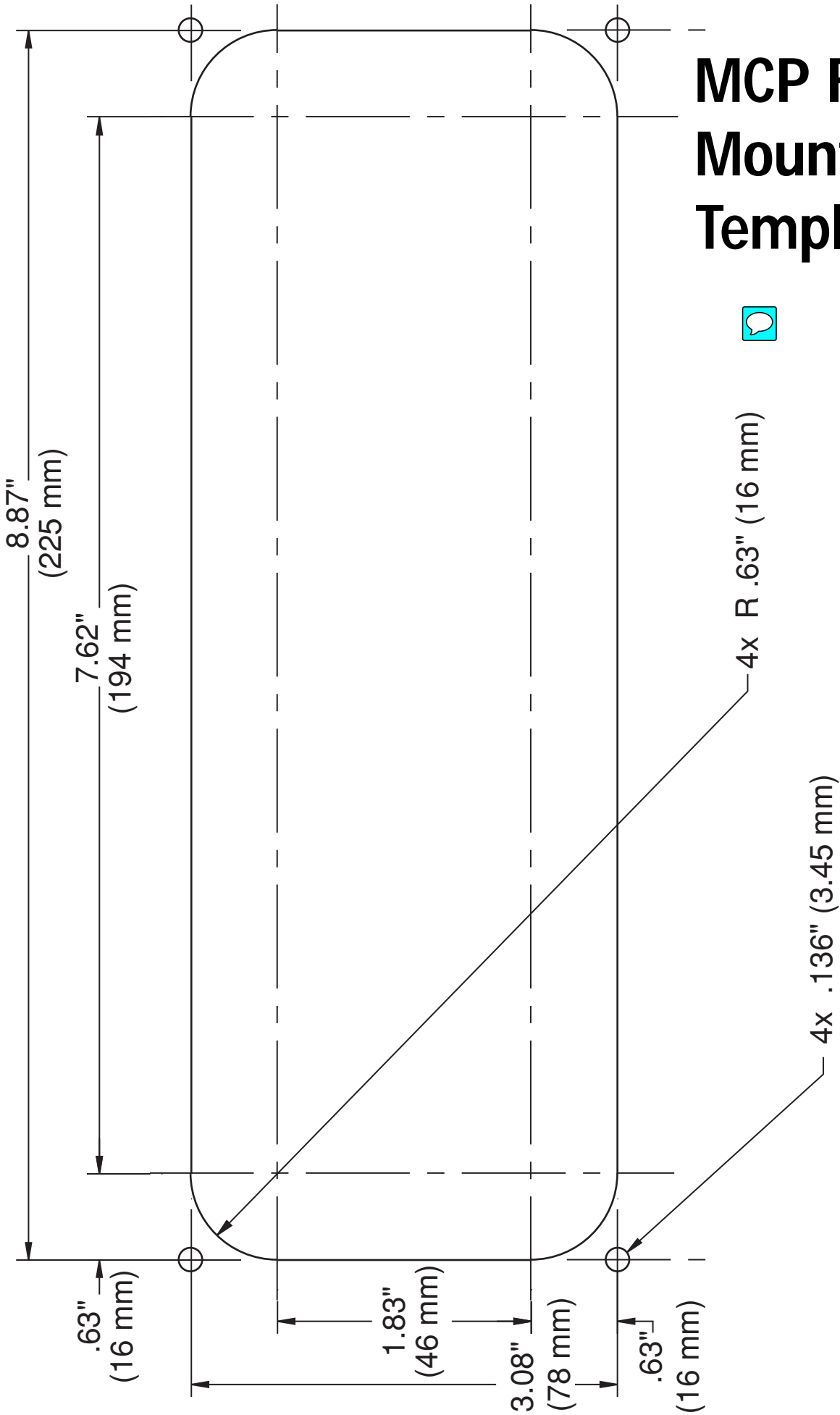



KVH Industries, Inc.

50 Enterprise Center Middletown, RI 02842-5279 U.S.A.
Phone: +1 401 847-3327 Fax: +1 401 849-0045
E-mail: info@kvh.com Internet: www.kvh.com

KVH Europe A/S

Kokkedal Industripark 2B 2980 Kokkedal Denmark
Phone: +45 45 160 180 Fax: +45 45 160 181
E-mail: info@kvh.dk Internet: www.kvh.com