

TRACVISION[®]
BY KVH INDUSTRIES

TracVision M7

Control Panel Configuration



TracVision M7 Installation Guide

TracVision M7 Installation Guide

MultiSat Control Panel (MCP) Configuration

These instructions explain how to install the TracVision M7 satellite TV antenna system on a vessel. Complete instructions on how to use the system are provided in the *User's Guide*.

Installation Steps

1. Inspect Parts and Get Tools, 3
2. Plan the Antenna Installation, 4
3. Plan the Belowdecks Installation, 5
4. Prepare the Belowdecks Sites, 6
5. Prepare the Antenna Site, 7
6. Remove the Restraint, 8
7. Wire the Antenna, 9
8. Mount the Antenna, 10
9. Modify the Switchplate (Optional), 11
10. Wire the Switchplate, 12
11. Wire the MCP and Receivers, 13
12. Connect Power, 14
13. Mount the Switchplate & MCP, 15
14. Enter Your Latitude & Longitude, 16
15. Select Satellites, 17
16. Get the LNB Skew Angle (Linear only), 18
17. Set the LNB Skew Angle (Linear only), 19
18. Educate the Customer, 20

Who Should Install the System?

To ensure a safe and effective installation, KVH recommends that a KVH-authorized marine technician install the TracVision antenna. KVH-authorized technicians have the tools and electronics expertise necessary to install the system. To find a technician near you, visit www.kvh.com/wheretogetservice.

Linear vs. Circular Systems

The installation process differs slightly depending on the type of LNB (low noise block) that is installed in the antenna (linear or circular). These differences are noted throughout this manual. Appendix D on page 31 notes the type of LNB required for each region and satellite.

Technical Support

If you need technical assistance, please contact KVH Technical Support:

North/South America, Australia:
Phone: +1 401 847-3327
E-mail: techs@kvh.com

Europe, Middle East, Asia:
Phone: +45 45 160 180
E-mail: support@kvh.dk

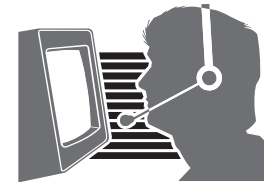

1 Inspect Parts and Get Tools

Before you begin, follow these steps to make sure you have everything you need to complete the installation.

- a. Unpack the box and ensure it contains everything shown on the *Kitpack Contents List*. Save the packaging for future use.

IMPORTANT!

Always lift the antenna by the baseplate and never by the radome or any portion of the internal antenna assembly (see Figure 1).

- b. Carefully examine all of the supplied parts to ensure nothing was damaged in shipment.
- c. Gather all of the tools and materials listed below. You will need these items to complete the installation.

- Flat-head and Phillips-head screwdrivers
- Electric drill and 1/2" (13 mm), 5/32" (4 mm), 3/32" (2.25 mm), and #29 bits
- 3" (80 mm) hole saw
- Socket wrenches
- 7/16" open-end wrench
- Light hammer and center punch
- Adhesive tape
- Scriber or pencil
- Wire strippers and terminal lug crimper
- RG-6 or RG-11 RF coax cable(s) with Snap-N-Seal® F-connectors for connecting the antenna to the receiver(s) (see Step 7a on page 9 to determine the number and type of cables required)
- Connector installation tool (Augat IT1000 - KVH part #19-0242)
- Power cables for connecting power to the switchplate and MCP (see Figure 2)
- Satellite TV receiver and TV

Figure 1: TracVision M7 System Components

Antenna

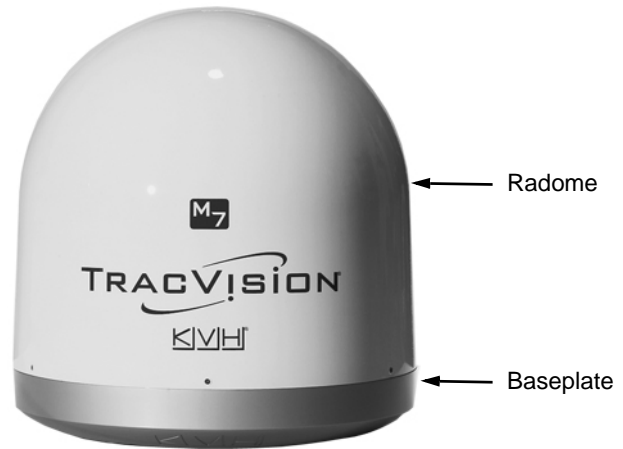

Switchplate



MCP (MultiSat Control Panel)



Figure 2: Guidelines for Power Cables

Cable Length	Use Cable Gauge
< 40 ft (12 m)	14AWG (2.5mm ²)
40-70 ft (12-21 m)	12AWG (4mm ²)

2 Plan the Antenna Installation

Before you begin, consider the following antenna installation guidelines:

- Minimize blockage. The antenna requires a clear view of the sky to receive satellite TV (see Figure 3). The fewer obstructions, the better the system will perform.
- Make sure the mounting surface is wide enough to accommodate the antenna's base (see Figure 4). Also make sure it is flat, level, strong enough to support the antenna's weight (55 lbs, 25 kg), and rigid enough to withstand vibration.
- Select a location that is as close as possible to the intersection of the vessel's fore-and-aft centerline and midships.
- Do not mount the antenna at the same level as the radar because the radar's energy might overload the antenna. Ideally, you should mount the antenna 4 ft (1.2 m) above and 4 ft (1.2 m) away from the radar.

Figure 3: Blockage from Obstruction

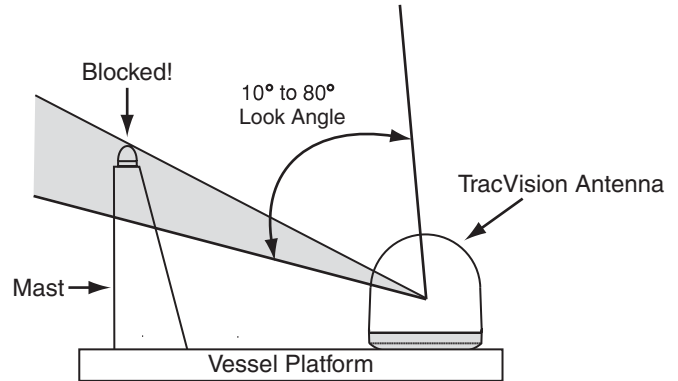
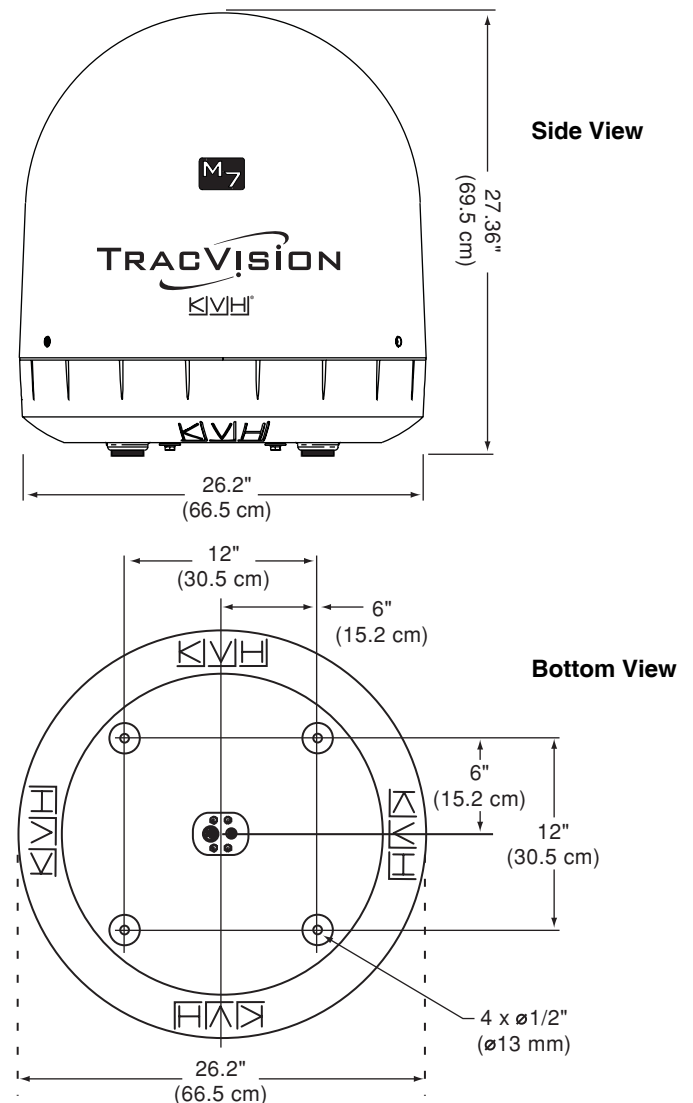

Figure 4: Antenna Dimensions



3 Plan the Belowdecks Installation

Before you begin, consider the following installation guidelines for the belowdecks equipment.

Switchplate

- Select a switchplate mounting location in a dry, well-ventilated area belowdecks away from any heat sources or salt spray.
- Be sure to leave enough room at the switchplate's rear panel for connecting the cables (see Figure 5 for switchplate dimensions).
- Since the supplied data cable is 100 ft (30 m) long, the switchplate must be located within 100 ft (30 m) of the antenna.
- The switchplate mounting template at the end of this manual shows the size of the hole required for a flush-mount installation.

MCP

- Select an MCP mounting location in a dry, well-ventilated area belowdecks away from any heat sources or salt spray.
- Be sure the MCP's front panel will be easily accessible to the user. The owner will use the MCP's buttons to control the antenna.
- Be sure to leave enough room at the MCP's rear panel for connecting the cables (see Figure 6 for MCP dimensions).
- Since the supplied main control cable and RF control cable are both 25 ft (7.6 m) long, the MCP must be located within 25 ft (7.6 m) of the switchplate. Later, you will connect the MCP to the switchplate using these special cables.
- The kitpack contains parts for mounting the MCP either to a horizontal surface (using Velcro) or to a vertical surface (using the supplied flush mount bracket). The MCP mounting template at the end of this manual shows the size of the hole required for a flush-mount installation.

Figure 5: Switchplate Dimensions

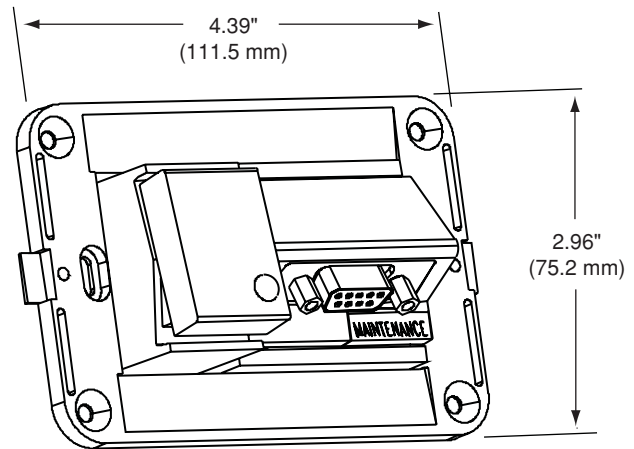
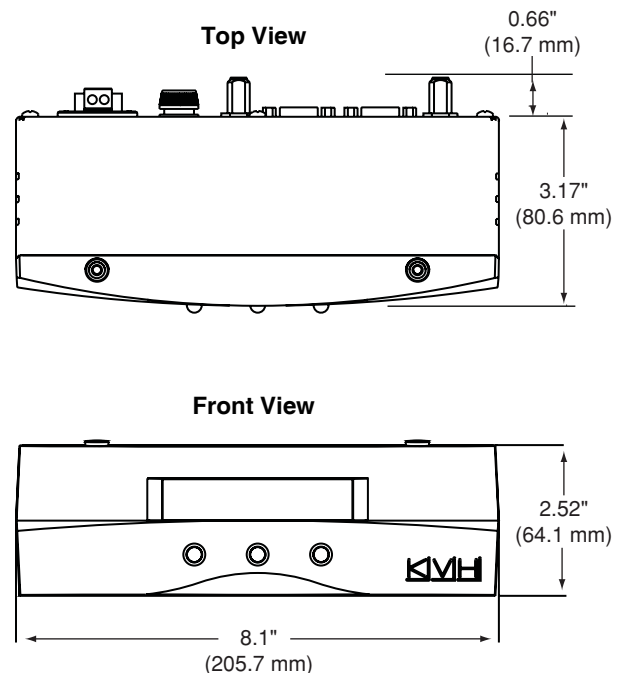

Figure 6: MCP Dimensions



4 Prepare the Belowdecks Sites

Once you have identified suitable mounting sites for the switchplate and MCP, follow these steps to prepare the sites for installation.

Switchplate

- Using the switchplate mounting template provided at the end of this manual, mark and cut out a hole in the mounting surface to accommodate the switchplate (see Figure 7).
- Using the same template, mark the locations for the four switchplate mounting holes.
- Drill a $3/32$ " (2.25 mm) hole at the four mounting hole locations. Later, you will mount the switchplate using four #6 screws.

MCP (Flush Mount only)

NOTE: Skip this step if you plan to mount the MCP to a horizontal surface instead.

- Attach the supplied flush mount bracket to the MCP now, before you connect any cables. Simply slide the bracket onto the MCP from behind and position the front edge of the bracket over the seam line between the front bezel and the chassis. Secure the bracket in place using two #6-32 screws and washers (see Figure 8).
- Using the MCP flush mounting template provided at the end of this manual, mark and cut out a hole in the mounting surface to accommodate the flush mount bracket (see Figure 9).
- Using the same template, mark the locations for the four MCP mounting holes.
- Using a #29 drill bit, drill a 0.136 " (3.45 mm) hole at the four mounting hole locations. Later, you will mount the MCP using four #8 screws.

Figure 7: Switchplate Mounting Holes Layout

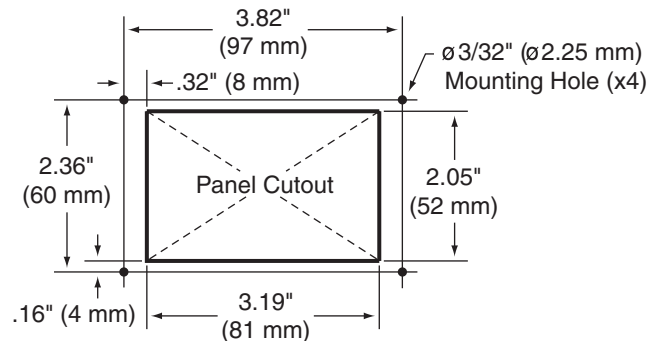

Figure 8: MCP Flush Mount Bracket

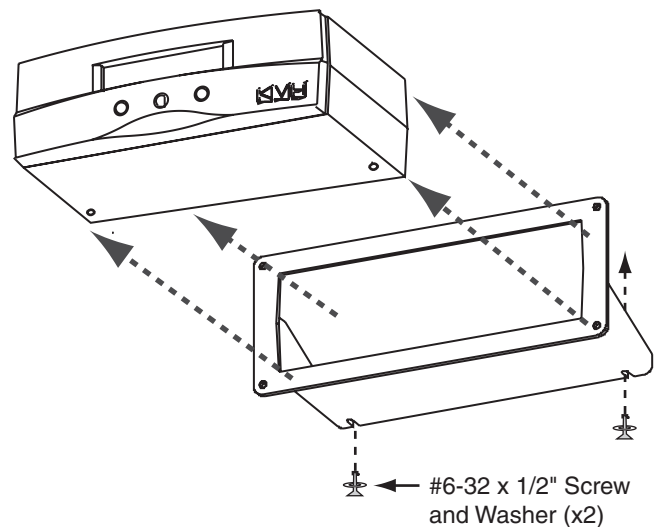
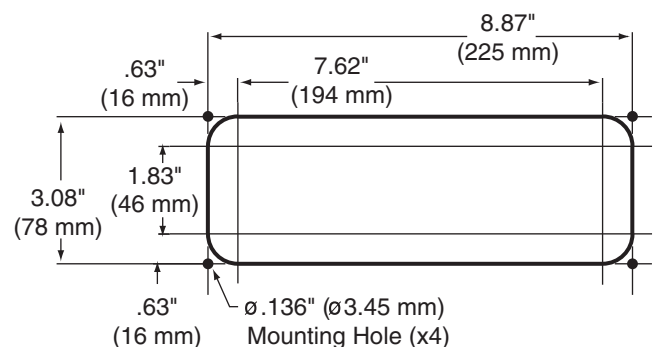

Figure 9: MCP Mounting Holes Layout



5 Prepare the Antenna Site

Once you have identified a suitable antenna mounting site, according to the guidelines provided in Step 2, follow these steps to drill the mounting holes and cable access hole to prepare the site for installation.

- a. Unfold the antenna mounting template (supplied in the Customer Welcome Kit) and place it onto the mounting surface. Make sure the "FWD" (forward) arrow points toward the bow and is parallel to the vessel's centerline (see Figure 10).

NOTE: You don't need to mount the antenna exactly on the vessel's centerline, but the antenna's forward arrow must be parallel to it.

- b. Use the template to mark the locations for the four mounting holes and cable access hole on the mounting surface.
- c. Drill a 1/2" (13 mm) hole at the four mounting hole locations you marked in Step 5b. Later, you will insert four 3/8"-16 bolts through these holes to secure the antenna to the mounting surface.
- d. Cut out the 3" (80 mm) cable access hole in the location you marked in Step 5b. Smooth the edges of the hole to protect the cables. Later, you will route the data, power, and RF cables through this hole and into the vessel.
- e. Clean and dry the antenna mounting surface.
- f. Peel off the paper backing from the supplied foam seal to expose the adhesive. Then press the foam seal down firmly onto the mounting surface, ensuring the hole in the foam seal aligns with the cable access hole in the mounting surface (see Figure 11).

Figure 10: Antenna Mounting Holes Layout

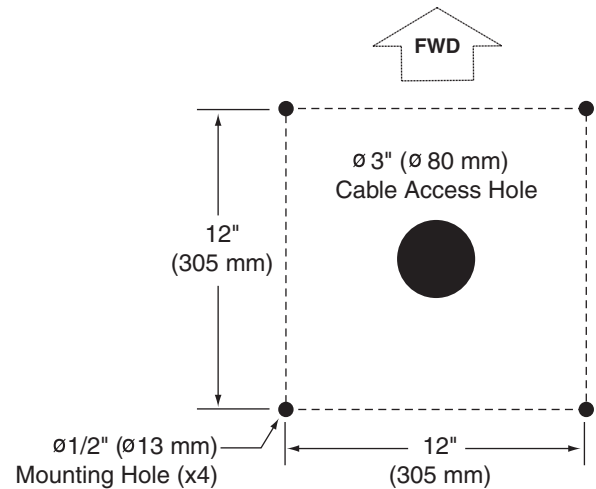

Figure 11: Foam Seal



6 Remove the Restraint

Inside the antenna, a foam block prevents the antenna assembly from moving during shipment. Follow these steps to remove this shipping restraint.

- a. Remove the six #10-32 Phillips screws securing the radome to the baseplate (see Figure 12). Carefully lift the radome straight up until clear of the antenna assembly and set it aside in a safe place.

TIP: If you keep the radome topside, secure it with a lanyard to prevent it from falling overboard.

- b. Remove the foam block that is wedged beneath the antenna's reflector (see Figure 13). Save this restraint for future use; the customer will need to reinstall it if he/she needs to relocate or reship the antenna.

IMPORTANT!

Once you have removed the restraint, handle the antenna very carefully. With the restraint removed, the internal antenna assembly rotates freely and, if not handled properly, can damage the limit switch.

Figure 12: Removing the Radome

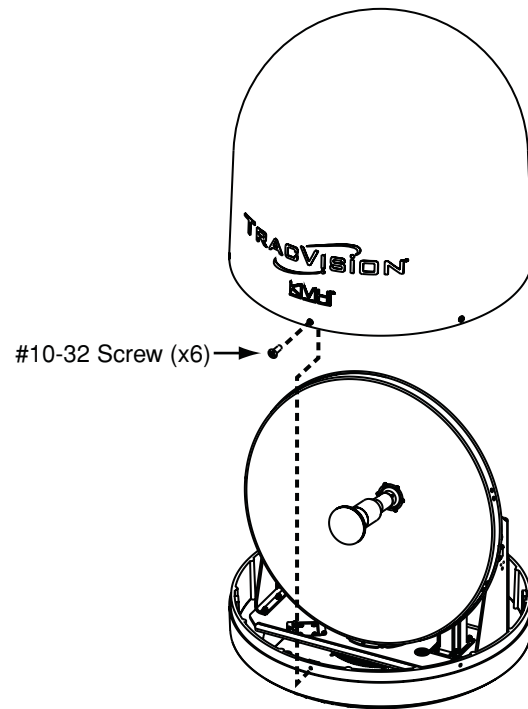

Figure 13: Foam Block Shipping Restraint



7 Wire the Antenna

Follow these steps to connect the data, power, and RF cables to the antenna.

- a. First determine the number of RF coax cables required for your particular installation (see Figure 14). (See Figure 15 to determine the type of cable required.)
- b. Route the data, power, and RF cables belowdecks through the 3" (80 mm) cable access hole. Leave an adequate service loop, approximately 8" (20 cm) of slack, in the cables for easy serviceability. Later, you will connect the data and power cables to the switchplate and the RF cable(s) to the receiver(s).
- c. Connect the data cable to the "Data" jack on the bottom of the antenna (see Figure 16). Hand-tighten until the connector locks in place; do not use excessive force.
- d. Connect the power cable to the "Power" jack on the bottom of the antenna. Hand-tighten until the connector locks in place; do not use excessive force.
- e. Connect the RF coax cable(s) to the antenna. If you need to connect just one RF cable, connect the cable to the "RF1" jack on the bottom of the antenna. Hand-tighten, then tighten with a 7/16" wrench for 1/4 turn to ensure an electrical and weather-proof connection. Connect any additional RF coax cables to the antenna's RF2, RF3, and RF4 jacks, in that order.

TIP: If you connect two or more RF cables, label both ends of each cable to match the connector. This will make it easier to identify the cables later.

Figure 14: Number of RF Coax Cables Required

Connecting to:	# RF Cables
<i>System with Dual LNB</i>	
1 receiver	1
2 or more receivers	2*
<i>System with Quad LNB (Europe Only)</i>	
1 receiver	1
2 receivers	2
3 receivers	3
4 or more receivers	4**

* Multiswitch required for 3 or more receivers.

** Multiswitch required for 5 or more receivers.

See Appendix B on page 28 for details.

Figure 15: RF Cable Guidelines

Cable Length	Use Cable Type
<= 75 ft (23 m)	RG-6
> 75 ft (23 m)	RG-11

Figure 16: Connectors on Bottom of Antenna

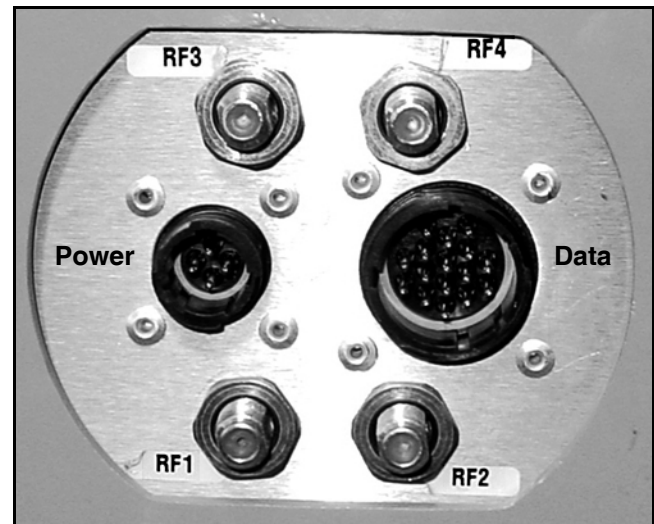

8 Mount the Antenna

Follow these steps to mount the antenna to the mounting surface.

- a. Place the antenna baseplate over the holes drilled in the mounting surface.
- b. Make sure the forward arrow inside the baseplate points toward the bow and is parallel to the vessel's centerline (see Figure 17).
- c. Make sure the four holes in the baseplate line up with the four holes in the mounting surface.

IMPORTANT!

You will need to rotate the antenna assembly by hand to see all four mounting holes. Rotate the antenna assembly slowly. If it hits a mechanical stop with excessive force, the limit switch might become damaged.

- d. At each of the four baseplate mounting holes, place a 3/8" flat washer on a 3/8"-16 bolt and insert the bolt into the hole from above (see Figure 18).
- e. Secure each mounting bolt to the mounting surface using a 3/8" shoulder washer, a 3/8" flat washer, and a 3/8"-16 lock nut from below. Tighten all four bolts until the four rubber feet are bottomed against the mounting surface and the foam seal is fully compressed.

TIP: If you are installing a linear system, you may wish to keep the radome off for now. Later, you will need to adjust the skew angle of the antenna's LNB.

- f. Reinstall the radome onto the antenna. Secure in place with the six #10-32 screws you removed in Step 6a (see Figure 12 on page 8).
- g. Install a protective plastic screw cap (supplied in the kitpack) over each radome screw.

Figure 17: Forward Arrow in Antenna Baseplate

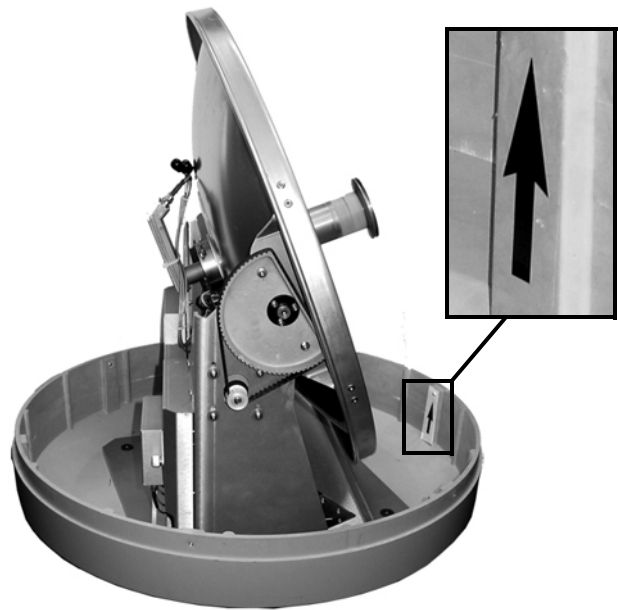
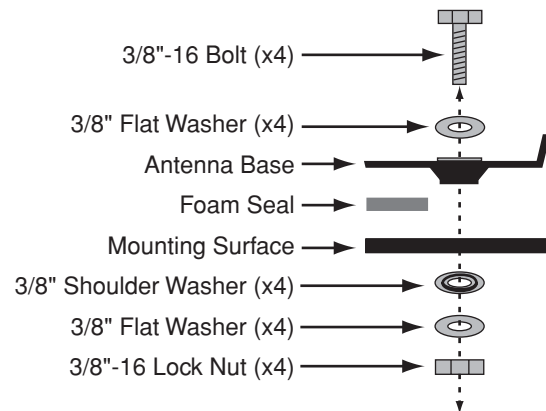

Figure 18: Mounting the Antenna (Side View)



9 Modify the Switchplate (Optional)

The switchplate comes preconfigured for a standard TracVision installation without an MCP. To configure the switchplate for an MCP installation, follow these steps to replace the maintenance port assembly in the switchplate with the MCP-ready maintenance port assembly supplied in the kitpack.

NOTE: The MCP-ready maintenance port assembly moves the DB9 maintenance port to the back of the switchplate. This allows you to later connect the main control cable to the back of the switchplate, hidden from view. However, if you wish, you may skip this step and simply connect the main control cable to the DB9 maintenance port on the front of the unmodified switchplate.

- a. Remove and discard the two jack screws securing the standard maintenance port assembly to the switchplate (see Figure 19). Remove and save the standard maintenance port assembly (see Figure 20).
- b. Attach the MCP-ready maintenance port assembly to the switchplate using two #4-24 screws (see Figure 21). These screws simply replace the jack screws you removed in Step 9a.

Figure 19: Detaching the Standard Maintenance Port Assembly

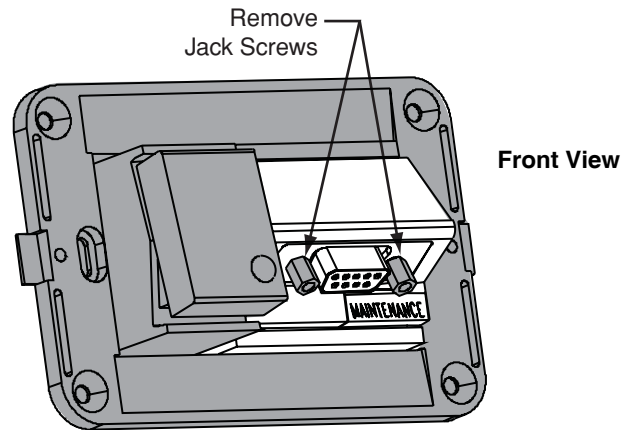

Figure 20: Standard Maintenance Port Assembly. Rear View.

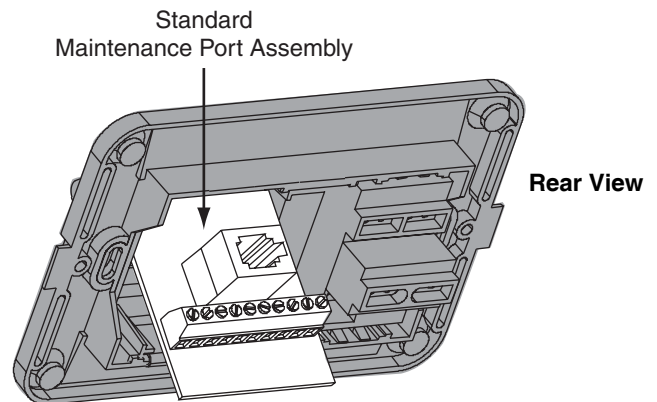
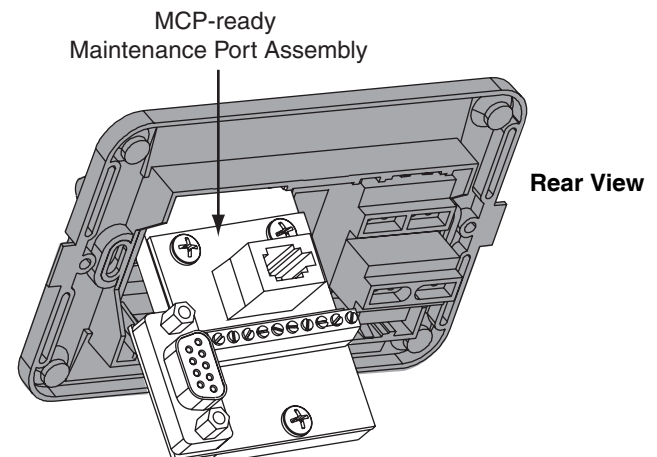

Figure 21: MCP-Ready Maintenance Port Assembly. Rear View.



10 Wire the Switchplate

Follow these steps to connect the switchplate to the antenna.

NOTE: System wiring diagrams are provided in Appendix F on page 36.

- a. First dress the data and power cables from the antenna. Strip back the insulation of each wire approximately 1/4" (6 mm) and gently twist each wire to ensure a good electrical connection.
- b. Connect the data cable from the antenna to the terminal board on the switchplate's maintenance port assembly (see Figure 22). Be sure to match the wire colors with the terminal board label. Tighten the terminal screws to secure all wires in place.

IMPORTANT!

The diagram refers to wires by **body color/ stripe color**. For example, "Brown/White" means the brown wire with the white stripe.

IMPORTANT!

Do not connect the data cable's drain wire (shield) to anything. You can simply snip it from the cable.

- c. Connect the power cable from the antenna to the switchplate's power output terminals (see Figure 23). Later, you will also connect a power cable from these terminals to the MCP.

Figure 22: Switchplate Wiring - Antenna Data Cable

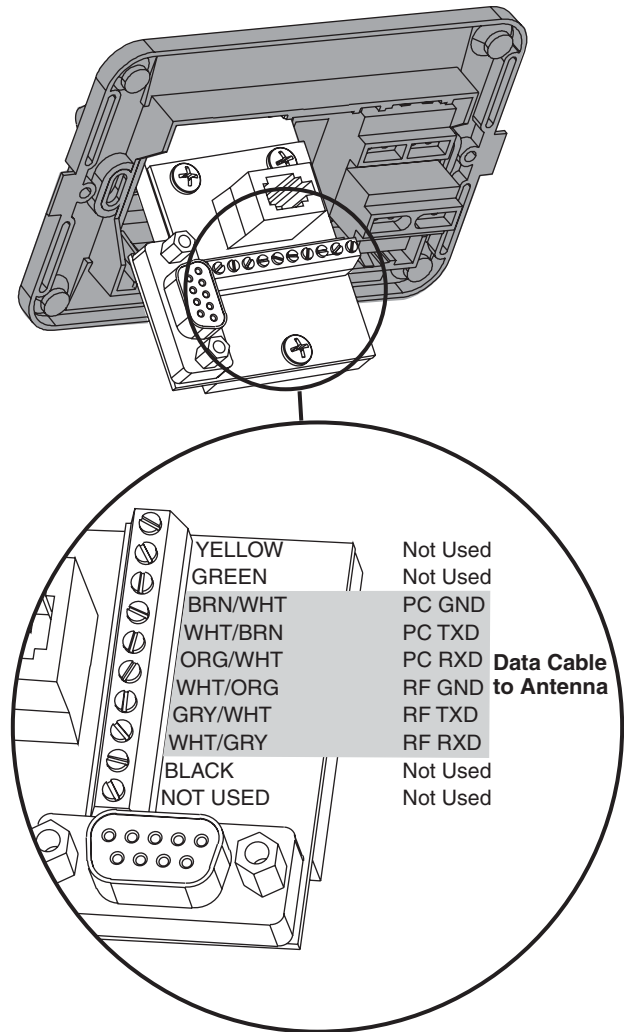
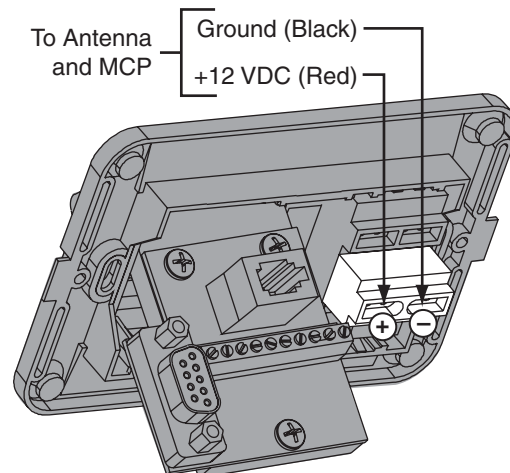

Figure 23: Switchplate Wiring - Antenna Power Cable



11 Wire the MCP and Receivers

Follow these steps to connect the switchplate to the MCP and the antenna to the receivers.

- a. Connect the main control cable (DB9-male to DB9-male) from the DB9 maintenance port jack on the switchplate to the “Antenna Unit” jack on the MCP (see Figure 24).
- b. Connect the RF control cable (RJ11 to DB9-female) from the RJ11 jack on the switchplate to the “RF Port” jack on the MCP.
- c. Using a P-clip, strain-relieve all wires at the switchplate by securing them to the bottom screw of the maintenance port assembly.

IMPORTANT!

If you are installing a **DIRECTV HDTV** system configuration, see Appendix A on page 23 for special wiring instructions.

IMPORTANT!

If you wish to connect **three or more** receivers to the antenna, see Appendix B on page 28.

- d. If you are connecting two receivers to the TracVision system, decide which receiver will be the primary receiver. The primary receiver controls satellite selection.

NOTE: The secondary receiver will only be able to select a channel carried on the satellite that is currently selected on the primary receiver.
- e. Connect the RF1 cable from the antenna to the “Satellite In” jack on the primary receiver.
- f. If you are connecting two receivers, connect the RF2 cable from the antenna to the “Satellite In” jack on the secondary receiver.

IMPORTANT!

Be sure all receivers are grounded. If the receiver has a 2-prong power plug, run a ground wire from the receiver’s chassis to a suitable ground point. If a potential exists between AC and DC grounds, connect the wire to the switchplate’s DC return instead.

Figure 24: MCP and Receiver Wiring

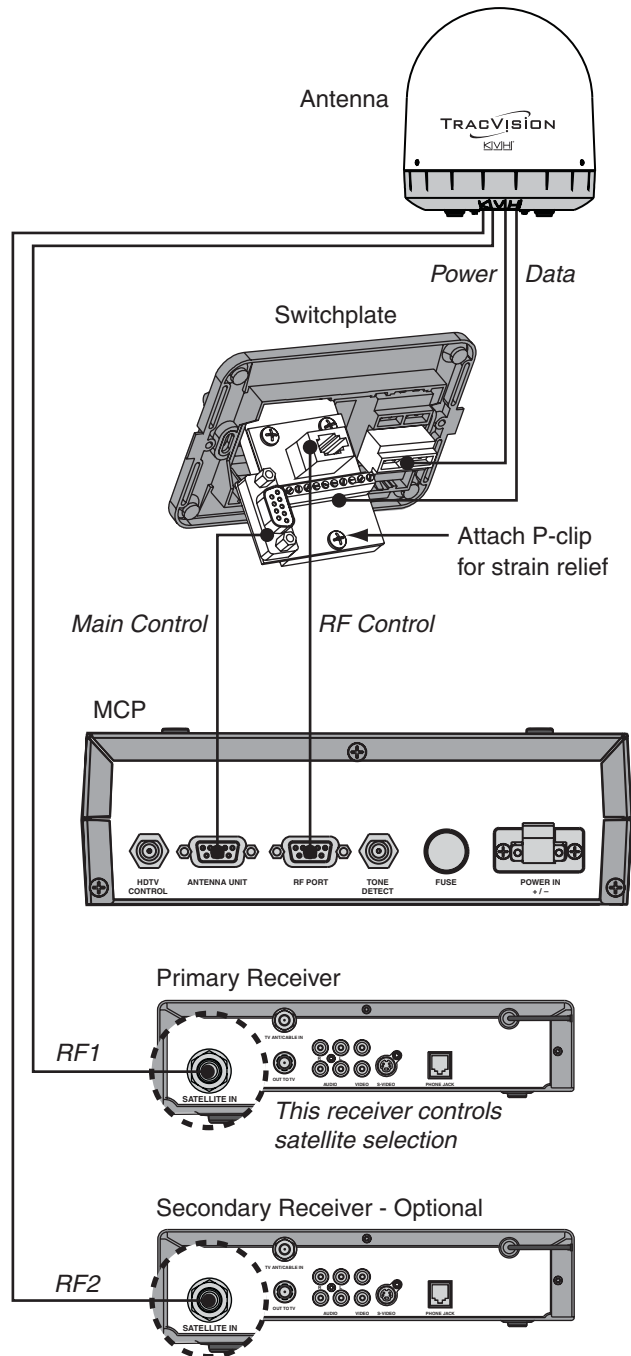

12 Connect Power

Follow these steps to connect power. The switchplate supplies power to both the antenna and the MCP.

- a. Before you begin, disconnect vessel power.

	CAUTION
For your own safety, disconnect vessel power and make sure the circuit is dead before you connect any power wires.	

- b. Route a set of power wires from the switchplate's power output terminals to the MCP (for cable specifications, see Figure 2 on page 3). Connect the wires to the plastic power plug supplied in the kitpack (see Figure 25).

NOTE: You should now have three wires connected to each power output terminal on the switchplate: one set of wires to power the antenna, one set to power the MCP, and one set to power the switchplate's indicator lamp (installed at the factory).

- c. Tighten the terminal screws on the switchplate to secure all wires in place.
- d. Plug the MCP power plug into the "Power In" jack on the MCP (see Figure 26). Secure in place with the retaining screws.
- e. Connect a power cable to 12 VDC vessel power (for cable specifications, see Figure 2 on page 3).

IMPORTANT!

Power supplied to the antenna must not fall below 11 VDC or exceed 16 VDC.

- f. Connect your vessel power wires to the power (+) and ground (-) input terminals on the switchplate (see Figure 27).

Figure 25: MCP Power Plug

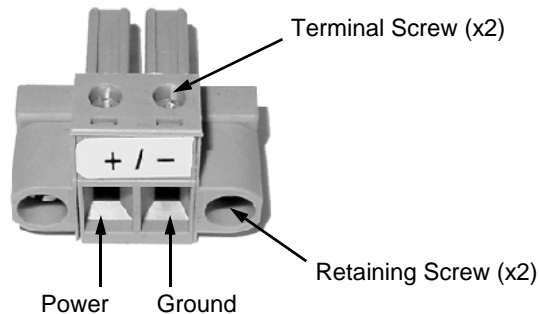

Figure 26: MCP Power Wiring

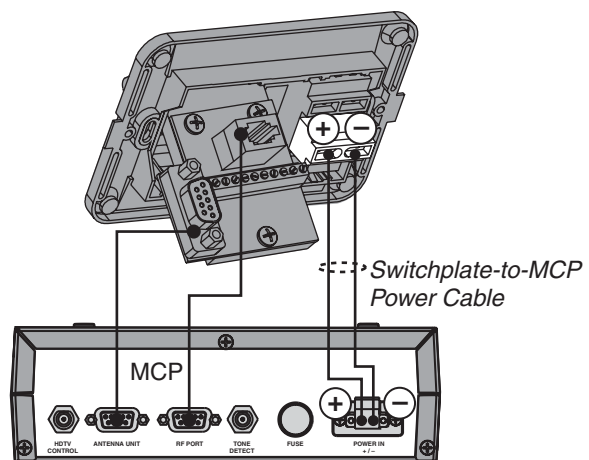
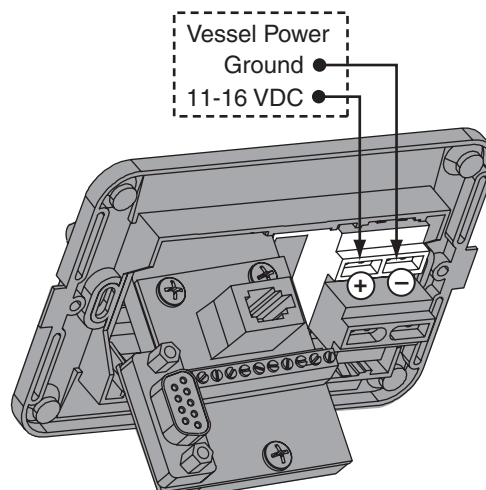

Figure 27: Switchplate Wiring - Vessel Power Cable



13 Mount the Switchplate & MCP

In Step 4, you prepared the mounting sites for the switchplate and MCP. Now follow these steps to mount them.

Switchplate

- a. Drill four 5/32" (4 mm) holes in the countersunk settings in the switchplate's support frame (see Figure 28).
- a. Fit the switchplate assembly into the mounting hole until it is flush with the mounting surface.
- b. Secure the support frame and switchplate assembly to the mounting surface using four #6 screws.
- c. Snap the front cover onto the switchplate to conceal the mounting screws and support frame.

Figure 28: Mounting the Switchplate

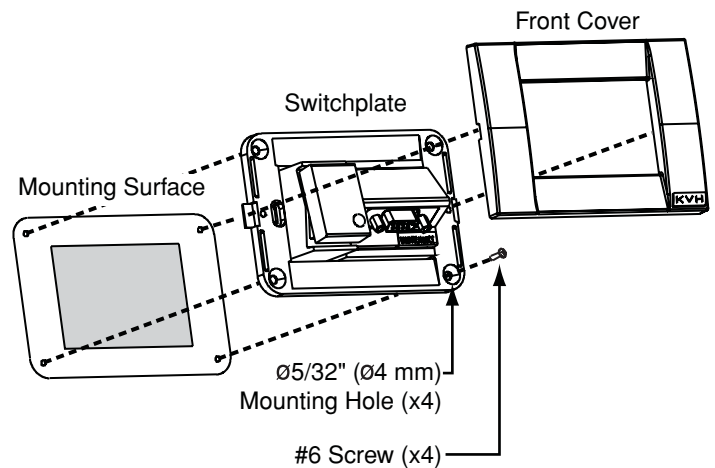

MCP - Velcro Mount Option

- a. Clean the bottom of the MCP and the mounting surface using a mild detergent.
- b. Peel the backing from the two supplied Velcro fabric squares and stick them to the bottom of the MCP (see Figure 29).
- c. Position the two Velcro hook disks onto the mounting surface. Drill screw holes for the disks and secure in place with #4-24 screws.
- d. Press the MCP firmly into place so that the fabric's loop material engages the hook disks.

Figure 29: Velcro Mounting the MCP to a Horizontal Surface

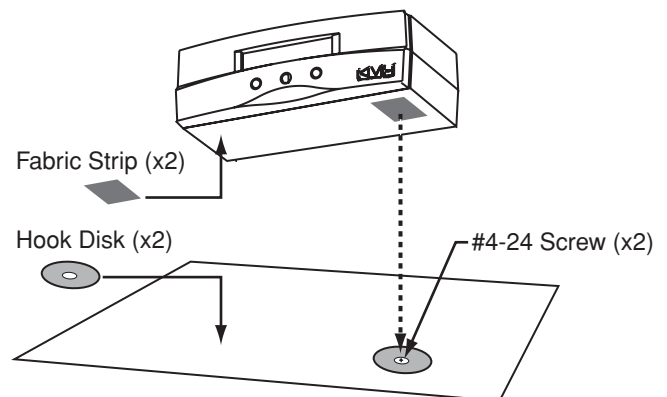

MCP- Flush Mount Option

- a. Make sure the flush mount bracket is attached to the MCP. If it is not attached, disconnect all of the cables from the MCP, attach the bracket as explained in Step 4 on page 6, then reconnect the cables.
- b. Insert the MCP and bracket assembly into the mounting hole and secure in place with four #8 screws and washers (see Figure 30).

Figure 30: Flush Mounting the MCP to a Vertical Surface

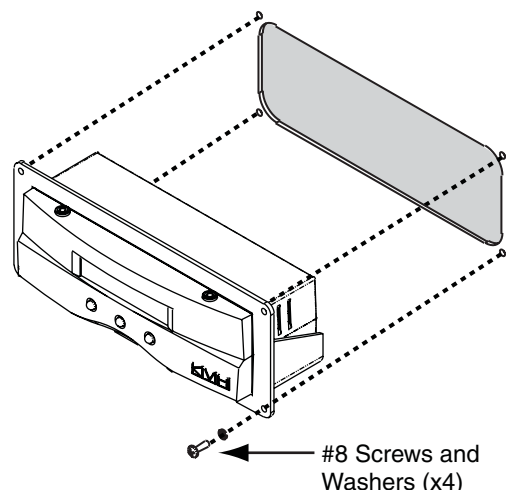

14 Enter Your Latitude & Longitude

Follow these steps to turn on the system and enter your vessel's latitude and longitude.

NOTE: The antenna will use your position information to speed up satellite acquisition. If the antenna knows where you are, it knows where it should start looking for the satellite. In addition, for a linear system, the antenna will use your position information to calculate the correct LNB skew angle.

- Ensure the antenna has a clear, unobstructed view of the sky.
- Apply power to the satellite TV receiver(s), TV(s), and switchplate (see Figure 31). Wait two minutes for system startup.
- Press the center **MENU** button on the MCP's front panel to access the onscreen menu (see Figure 32).
- At "Install satellite?", press **NEXT** until the display shows "Operations mode?" Then press **YES**.
- At "Get antenna status?", press **NEXT** until the display shows "Control antenna?" Then press **YES**.
- At "Man control antenna?", press **NEXT** until the display shows "Set Lat/Long?" Then press **YES**.
- At "Latitude", use the - and + buttons to set each digit of the vessel's latitude. Press **ENTER** to accept each digit.
- At "Longitude", use the - and + buttons to set each digit of the vessel's longitude. Press **ENTER** to accept each digit.
- At "Latitude/Longitude", verify that the display shows the correct latitude and longitude.
- After 3 seconds, the display returns to the "Set Lat/Long?" screen. Press **RETURN** until you exit the menu.

Figure 31: Switchplate Power Switch

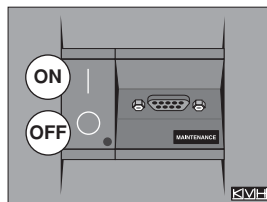
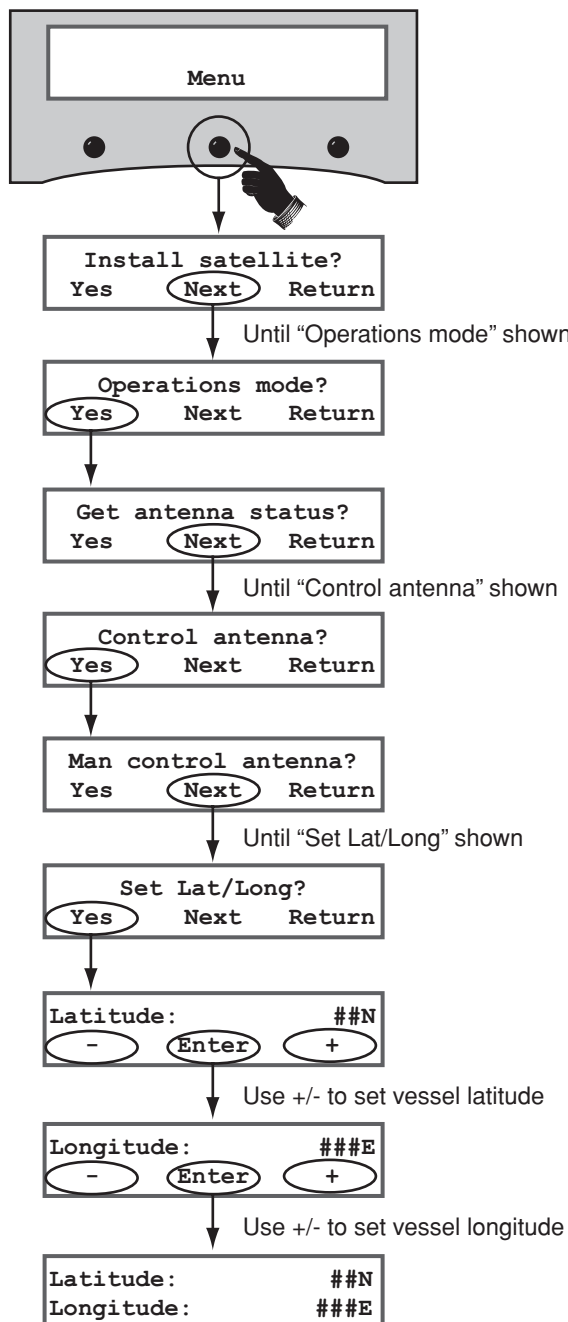

Figure 32: Lat/Long Menus on MCP



15 Select Satellites

Follow these steps to set up the system for the desired pair of satellites.

IMPORTANT!

To select a three-satellite (Trisat) group for a linear system, see Appendix C on page 30. To select a DIRECTV HDTV three-satellite (Trisat) group, see Appendix A on page 23.

- a. Press the center **MENU** button on the MCP's front panel to access the onscreen menu (see Figure 33).
- b. At "Install Satellite?", press **YES**.
- c. At "Trisat Mode?", press **NO**.
- d. At "Install A <SAT NAME>", press **NEXT** until the display shows the first (primary) satellite you want to select. Then press **YES**. (See Appendix D on page 31 for a list of available satellites.)

NOTE: If you don't find the satellite you want, you can set up a user-defined satellite (USER 1 or USER 2). See Appendix E on page 32.
- e. Repeat Step 15d to select the second satellite. If you want to set up the antenna to track just one satellite, select "None" instead.
- f. Wait two minutes while the antenna restarts.
- g. **(Linear only)** Set up the receiver(s) for the same satellites, and in the same order, that you set them up in the antenna:

Antenna	Receiver	DiSEqC
Sat. A	Alternative 1 or A	DiSEqC 1
Sat. B	Alternative 2 or B	DiSEqC 2

Figure 33: Satellite Selection Menus on MCP

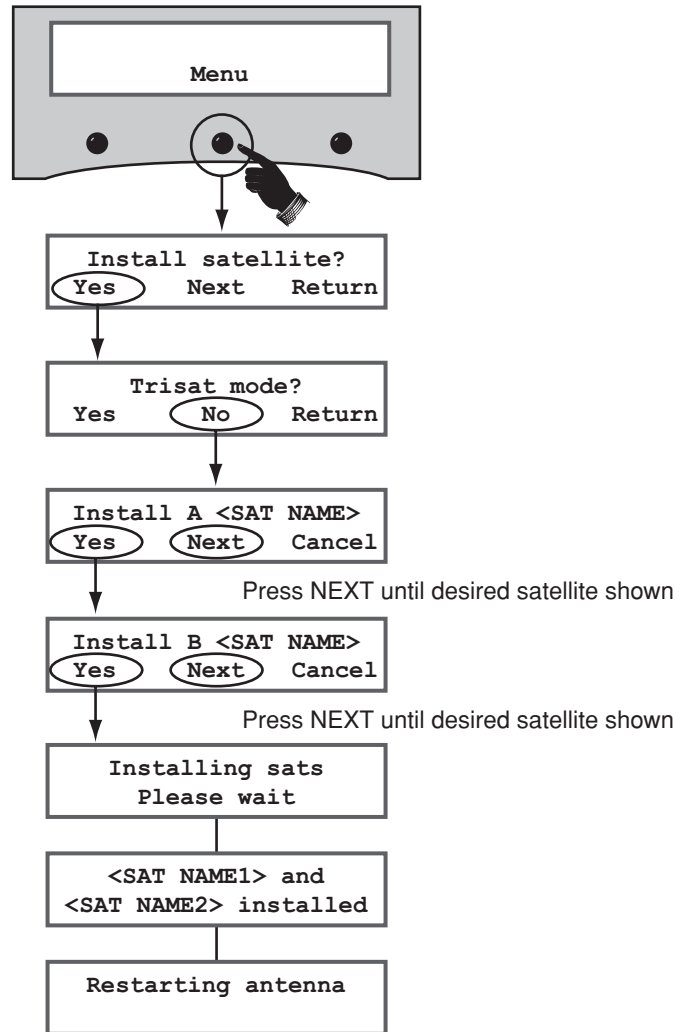

16 Get the LNB Skew Angle (Linear only)

To optimize reception, the antenna's LNB must be set to the correct skew angle for the linear satellite(s) you want to track. Follow these steps to determine what the correct skew angle should be for the currently selected satellite and vessel position.

TIP: You might also be able to get the correct skew angle from the customer's satellite service provider.

- Press the center **MENU** button on the MCP's front panel to access the onscreen menu (see Figure 34).
- At "Install satellite?", press **NEXT** until the display shows "Operations mode?" Then press **YES**.
- At "Get antenna status?", press **YES**.
- At "Get system errors?", press **NEXT** until the display shows "Get skew angle?" Then press **YES**.
- The display shows the calculated skew angle for the selected satellite and position (which you entered in Step 14). Note this number for future reference.
- Press any button. The display returns to the "Get skew angle?" screen.
- Press **RETURN** until you exit the menu.

*TIP: This procedure provides the correct skew angle for the currently selected satellite only. If you installed a pair of satellites in Step 15, you might wish to calculate the **average skew** for the two satellites and set the LNB to that skew angle instead. To find the average skew, first select the second satellite and repeat the procedure above to get the calculated skew angle for the second satellite. Then add the two skew angle numbers together and divide by two to get the average skew angle.*

Figure 34: Skew Angle Menus on MCP

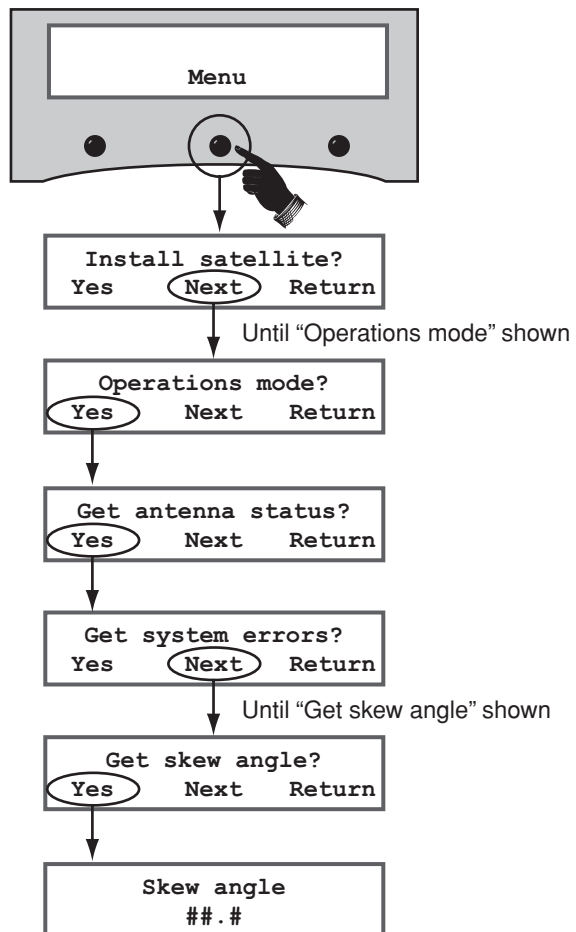

17 Set the LNB Skew Angle (Linear only)

Follow these steps to set the antenna's LNB to the skew angle you noted in Step 16.

- Turn off and unplug the receiver(s).
- Disconnect antenna power at the switchplate.

	CAUTION
Disconnect power from the antenna and the receivers before you adjust the LNB. The antenna's moving parts can cause injury.	

- Remove the antenna's radome, if you installed it earlier in Step 8f.

TIP: If you keep the radome topside, secure it with a lanyard to prevent it from falling overboard.

- Locate the LNB on the back of the antenna's reflector (see Figure 35).
- Loosen the two wing screws on the LNB choke feed. These wing screws secure the LNB in place.
- Adjust the LNB clockwise or counter-clockwise until the skew arrow on the LNB points to the skew angle you noted in Step 16 (see Figure 36).

IMPORTANT!
Be sure to keep the LNB fully inserted into the choke feed to ensure optimum performance.

- Tighten the wing screws to secure the LNB in place.
- Reinstall the radome (as explained in Steps 8f-g on page 10).

Figure 35: Wing Screws Securing the LNB to the Reflector

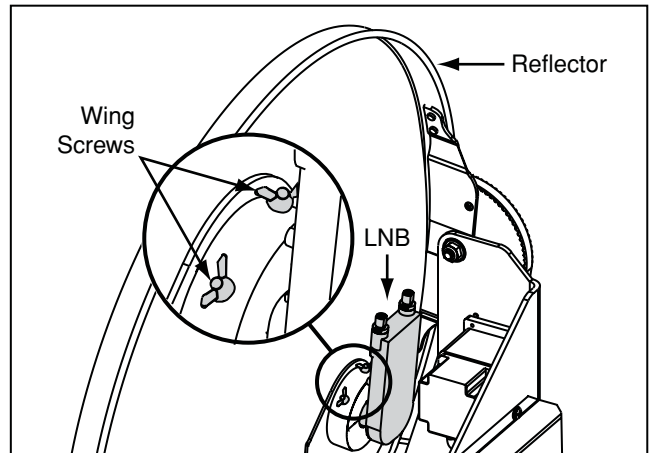
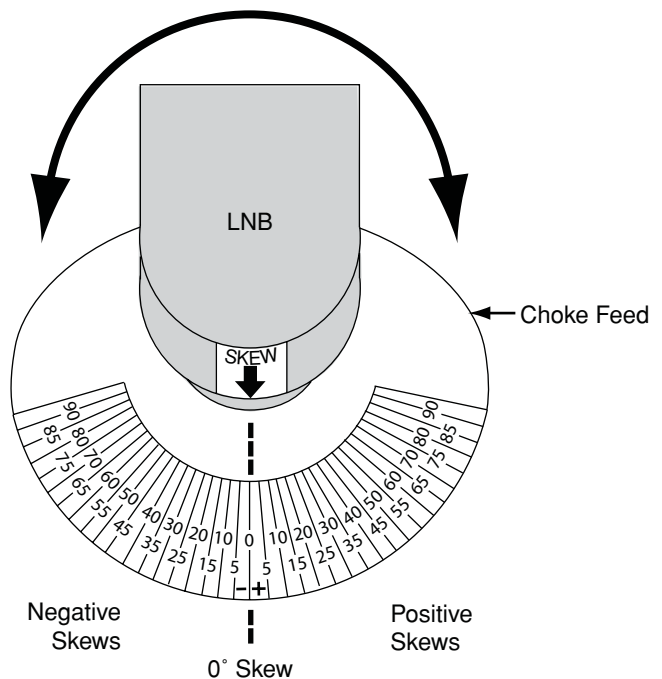

Figure 36: LNB Skew Angle Adjustment



18 Educate the Customer

The installation process is complete!

Before you depart the vessel, test the system to verify the antenna works properly. Then give the Customer Welcome Kit to the customer and explain how to use the system. Also be sure the customer understands the following:

- Keep the radome installed on the antenna at all times. The radome protects the antenna's moving parts from wind, rain, and debris.



WARNING

It is dangerous to watch TV while piloting a vessel. The TracVision system is intended as a passenger entertainment product only.

- The antenna must have a clear view of the sky to receive satellite TV. Common causes of blockage include trees, buildings, bridges, and onboard equipment (see Figure 37).
- Heavy rain or snow may temporarily interrupt reception.
- Clean the antenna regularly. Dirt buildup on the radome can affect reception.
- The vessel must be located within the selected satellite's coverage area to receive its satellite TV signals. To view satellite coverage maps, visit www.kvh.com/footprint.
- Please register the system with KVH. The registration process is quick, easy, online, and ensures the best possible service from KVH. Visit www.kvh.com/register or refer to the Product Registration Form for details.
- You need to activate the receiver for the desired satellite TV service before the receiver can decode satellite signals. KVH can help you activate a DIRECTV receiver; just call KVH's Activation Department at 1-888-584-4163 (Mon.-Fri., 8:30 am - 5 pm ET)
- Refer to the *User's Guide* for complete operation instructions and troubleshooting information.

Figure 37: Example of Satellite Blockage

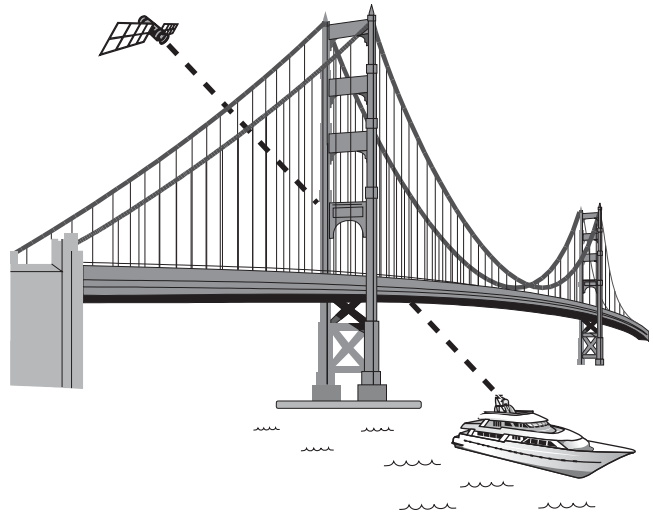

Appendices

This section provides supplemental instructions for special or advanced configurations. It also provides system wiring diagrams and mounting templates for the belowdecks equipment.

Contents

- A. DIRECTV HDTV Installation, 23
 - B. Wiring 3+ Receivers, 28
 - C. Selecting a Trisat Group (Linear only), 30
 - D. Satellite Library, 31
 - E. User-Defined Satellites, 32
 - F. Wiring Diagrams, 36
- Switchplate Mounting Template, 43
- MCP Flush Mounting Template, 45

A DIRECTV HDTV Installation

Appendix

These supplemental instructions explain how to configure the system for DIRECTV HDTV using KVH's optional HDTV converter. To complete a basic, single-receiver configuration, you will need the following components:

- HDTV converter (KVH part #02-1431)
- Splitter (KVH part #19-0366)
- DIRECTV HD receiver
- HDTV television

The HDTV converter adjusts the signal frequency of DIRECTV's 110 satellite, allowing the system to receive its high-definition channels. This configuration also allows the system to receive signals from DIRECTV's 101 and 119 satellites for a three-satellite (Trisat) setup.

Wiring a Single DIRECTV HD Receiver

Follow these steps to connect the HD receiver.

IMPORTANT!

If you wish to connect two or more HD receivers to the antenna, you will need to install an active multiswitch. See the next section for special wiring instructions.

1. Connect an RF coax cable from the "HDTV Control" jack on the MCP to the "Control Input" jack on the HDTV converter (see Figure 38).
2. Connect the RF1 cable from the antenna to the "RF Input" jack on the HDTV converter.
3. Connect an RF coax cable from the "RF Out" jack on the HDTV converter to either of the "Out" jacks on the splitter.
4. Connect an RF coax cable from the "Tone Detect" jack on the MCP to the other "Out" jack on the splitter.
5. Connect an RF coax cable from the "Input" jack on the splitter to the "Satellite In" jack on the DIRECTV HD receiver.

Figure 38: Wiring a Single DIRECTV HD Receiver

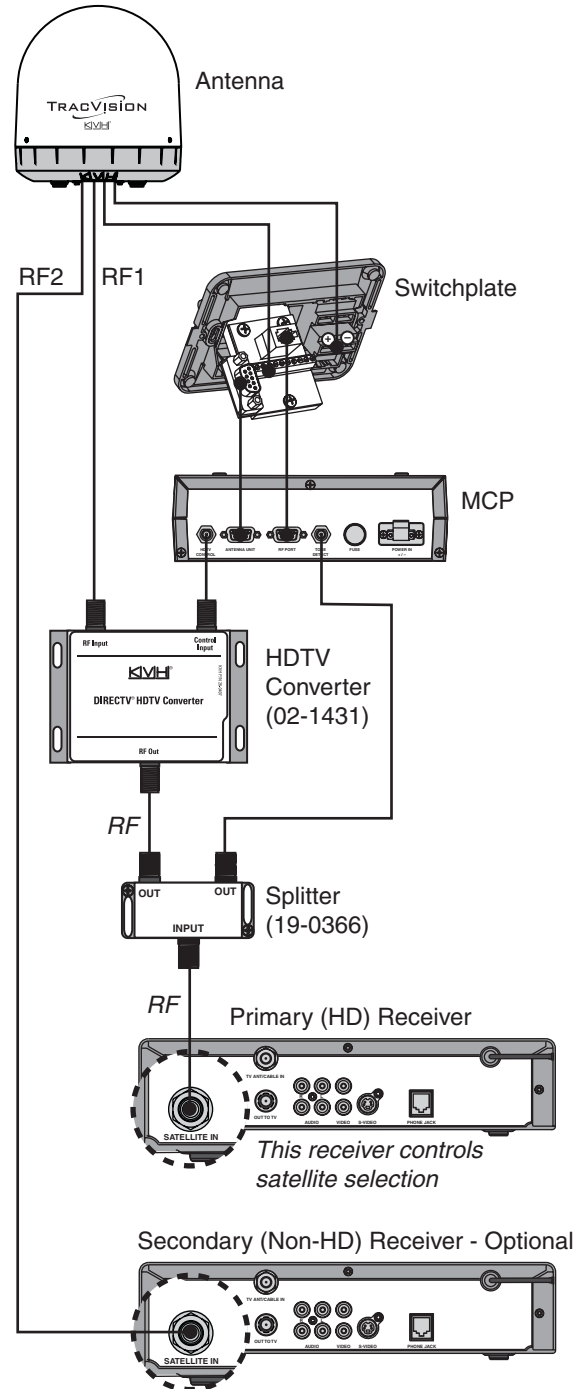

A Continued...

- If you wish to connect a second, standard (**non-HD**) receiver to the antenna, connect the RF2 cable from the antenna to the "Satellite In" jack on the secondary receiver.

IMPORTANT!

The HD receiver is the primary receiver that controls satellite selection. The secondary receiver will only be able to select a channel on the satellite that is currently selected on the primary HD receiver. In addition, the secondary receiver **must** be standard-definition only (not HD) in this configuration.

IMPORTANT!

Be sure all receivers are grounded. If the receiver has a 2-prong power plug, run a ground wire from the receiver's chassis to a suitable ground point. If a potential exists between AC and DC grounds, connect the wire to the switchplate's DC return instead.

- Follow the instructions in Steps 12 and 13 on pages 14-15 to connect power and mount the switchplate and MCP. Then skip to page 26 to select satellites.

Wiring Multiple DIRECTV HD Receivers

If you need to connect two or more HD receivers, follow these alternate steps to install an active (powered) multiswitch between the antenna and the receivers (see Figure 39).

NOTE: You can purchase an active multiswitch, Channel Master model 6314IFD, from KVH (order part #19-0123).

- Connect the RF1 cable from the antenna to the "RHCP +13V" jack on the multiswitch.
- Connect the RF2 cable from the antenna to the "RF Input" jack on the HDTV converter.
- Connect an RF coax cable from the "HDTV Control" jack on the MCP to the "Control Input" jack on the HDTV converter.

Figure 39: Wiring Multiple DIRECTV HD Receivers

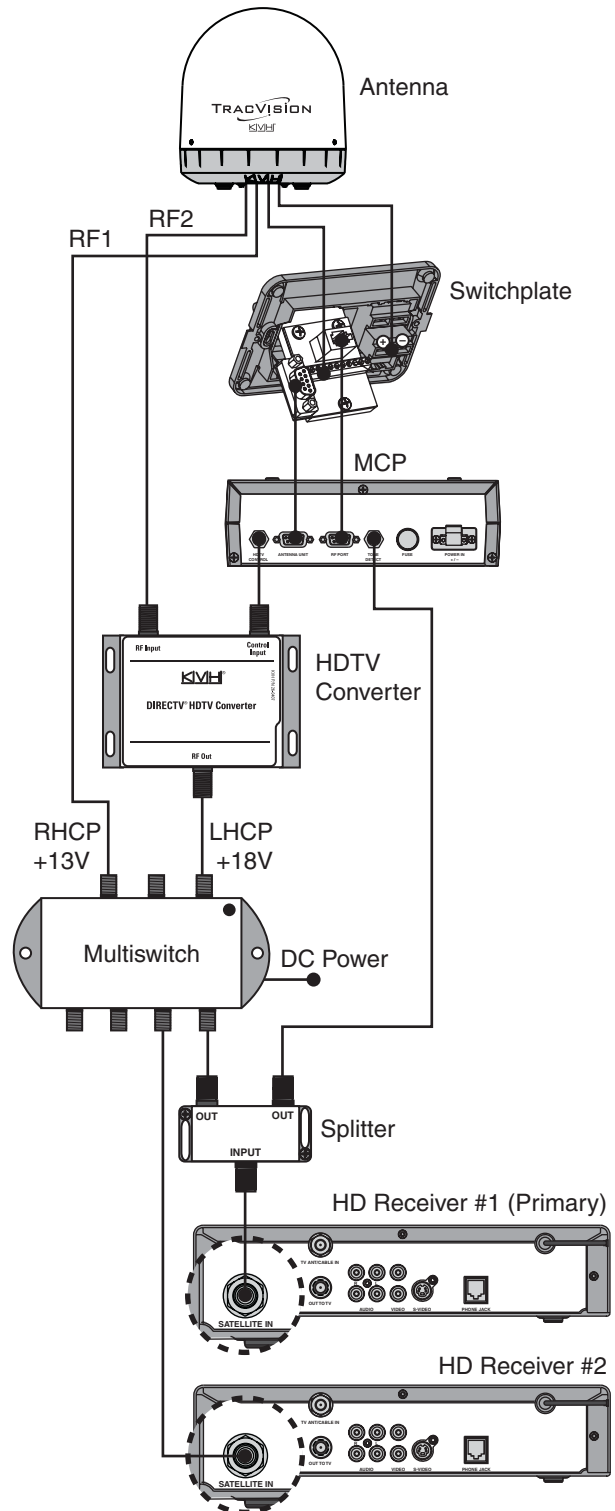

A Continued...

4. Connect an RF coax cable from the "RF Out" jack on the HDTV converter to the "LHCP +18V" jack on the multiswitch.
5. Connect an RF coax cable from the "Tone Detect" jack on the MCP to either of the "Out" jacks on the splitter.
6. Connect an RF coax cable from any output of the multiswitch to the available "Out" jack on the splitter.
7. Connect an RF coax cable from the "Input" jack on the splitter to the "Satellite In" jack on the primary HD receiver. This receiver will control satellite selection.
8. Connect any additional HD or standard receivers to the available outputs of the multiswitch.

IMPORTANT!

The receiver you connected to the splitter is the primary receiver that controls satellite selection. The secondary receiver(s) will only be able to select a channel on the satellite that is currently selected on the primary receiver.

9. Terminate any unused multiswitch outputs with 75 ohm DC blocks (Channel Master #7184, Radio Shack #15-1259, or equivalent).

IMPORTANT!

Be sure the multiswitch is properly grounded. With the multiswitch grounded, you do not need to ground the individual receivers.

10. Follow the instructions in Steps 12 and 13 on pages 14-15 to connect power and mount the switchplate and MCP. Then skip to page 26 to select satellites.

A Continued...

Selecting the DIRECTV Trisat Group

Follow these steps to turn on the system and set it up for Trisat mode. In Trisat mode, the system tracks and receives TV signals from three DIRECTV satellites (101, 119, and 110). The 110 satellite carries most of DIRECTV's HD programming.

1. Ensure the antenna has a clear, unobstructed view of the sky.
2. Apply power to the satellite TV receiver(s), TV(s), and switchplate. Wait two minutes for system startup.
3. Press the center **MENU** button on the MCP's front panel to access the onscreen menu (see Figure 40).
4. At "Install Satellite?", press **YES**.
5. At "Trisat Mode?", press **YES**.
6. At "USA or Europe?", press **USA**. The MCP installs the Trisat group of satellites into the antenna.
7. Now you need to choose a Sat Select mode: **Automatic** or **Manual** (see the next section for a brief description of each). At "Set Sat Select Mode", press **AUTO** to select Automatic mode, or press **MANUAL** to select Manual mode.
8. If you selected Automatic mode, at "Select SAT 101 and", select a satellite pair:
 - Press **119** for 101-119
 - Press **110** for 101-110
9. The antenna restarts. Wait two minutes for system startup.

Figure 40: DIRECTV Trisat Group Selection Menus on MCP

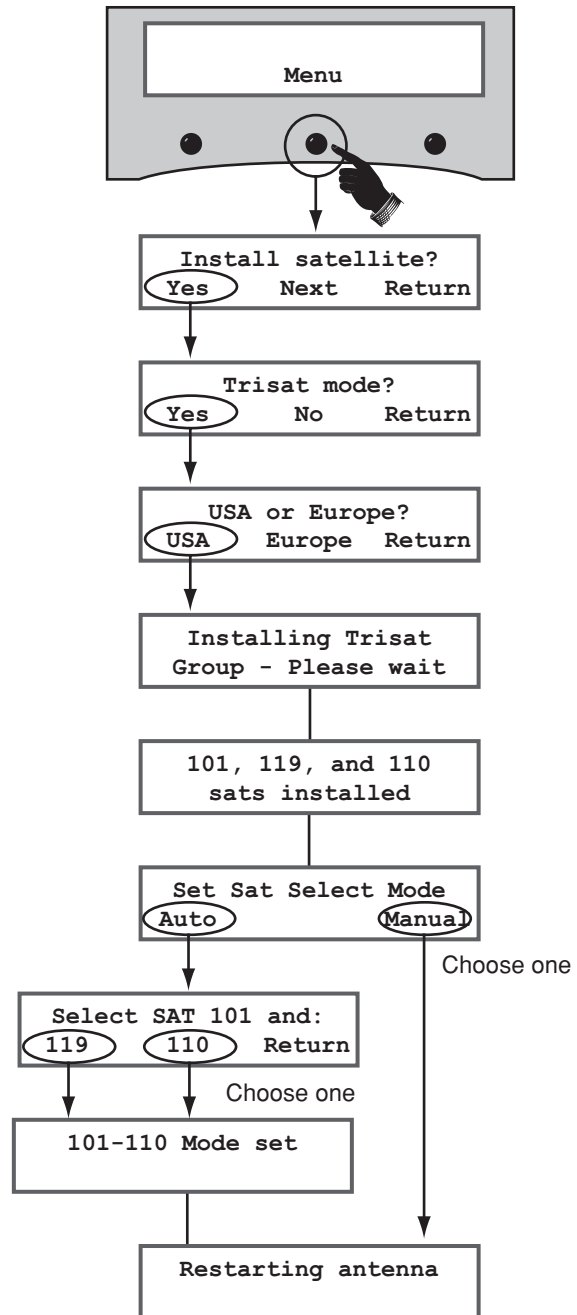

A Continued...

Sat Select Modes

In **Automatic** mode, the antenna automatically switches between a pair of satellites as the user changes channels on the receiver's remote. The user sets the MCP to automatically switch between either 101-110 or 101-119 (see Figure 41).

In **Manual** mode, the user presses a button on the MCP whenever he/she wishes to switch satellites. The user can select between 101, 110, and 119 (see Figure 42).

Educate the Customer About HDTV

- Make sure the DIRECTV HD receiver is set up for an "Oval, 3 LNB" dish (antenna) type, so that the receiver can decode channels from three DIRECTV satellites. Refer to the receiver's user manual for details.
- The HD receiver will only be able to decode HD channels if it is activated. High-definition channels are not included with the basic DIRECTV package, and premium HD channels, such as HBO HD, must be ordered separately. KVH makes activation easy. Just call KVH's Activation Department at 1-888-584-4163 (Mon.-Fri., 8:30 am - 5 pm ET).
- KVH provides a list of HD channels, and the DIRECTV satellites that carry them, at www.kvh.com/HDlineup. Since DIRECTV changes its channel lineups frequently, KVH can e-mail updates to you whenever the HD lineup changes. Register for this free service when you visit the website for the first time.
- On startup, the receiver needs to download the Program Guide from the 101 satellite. Be sure the antenna is tracking the 101 satellite whenever you reboot the receiver.
- Please be patient during the Program Guide download. It may take more than 20 minutes for the receiver to download the entire Program Guide, which lists channels available on every DIRECTV satellite. A channel is selectable only if it is loaded in the Program Guide.

Figure 41: Automatic Sat Select Mode

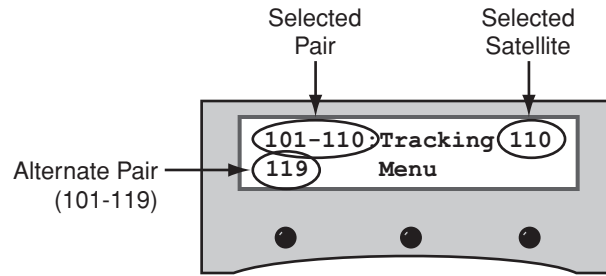
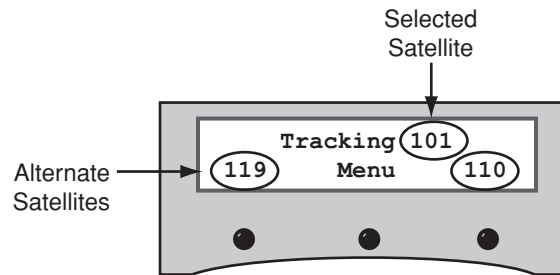

Figure 42: Manual Sat Select Mode



B Wiring 3+ Receivers

IMPORTANT!

Only antennas equipped with a circular dual LNB or a linear quad LNB can support more than two receivers. Antennas equipped with a linear dual LNB support only two receivers.

Antenna with Circular Dual LNB

(North American systems only)

To connect three or more receivers, follow these steps to install an active (powered) multiswitch between the antenna and the receivers.

NOTE: You can purchase an active multiswitch, Channel Master model 6314IFD, from KVH (order part #19-0123).

1. Connect the RF1 cable from the antenna to the "RHCP +13V" jack on the multiswitch (see Figure 43).
2. Connect the RF2 cable from the antenna to the "LHCP +18V" jack on the multiswitch.
3. Connect the receivers to the individual outputs of the multiswitch.
4. Terminate any unused multiswitch outputs with 75 ohm DC blocks (Channel Master #7184, Radio Shack #15-1259, or equivalent).

IMPORTANT!

Be sure the multiswitch is properly grounded. With the multiswitch grounded, you do not need to ground the individual receivers.

IMPORTANT!

(DIRECTV only) Multiswitches block a receiver's 22 KHz tone that the antenna needs to switch satellites automatically. Therefore, the customer will need to manually switch satellites using the buttons on the MCP.

Figure 43: Multiswitch Wiring - Antenna with Circular Dual LNB

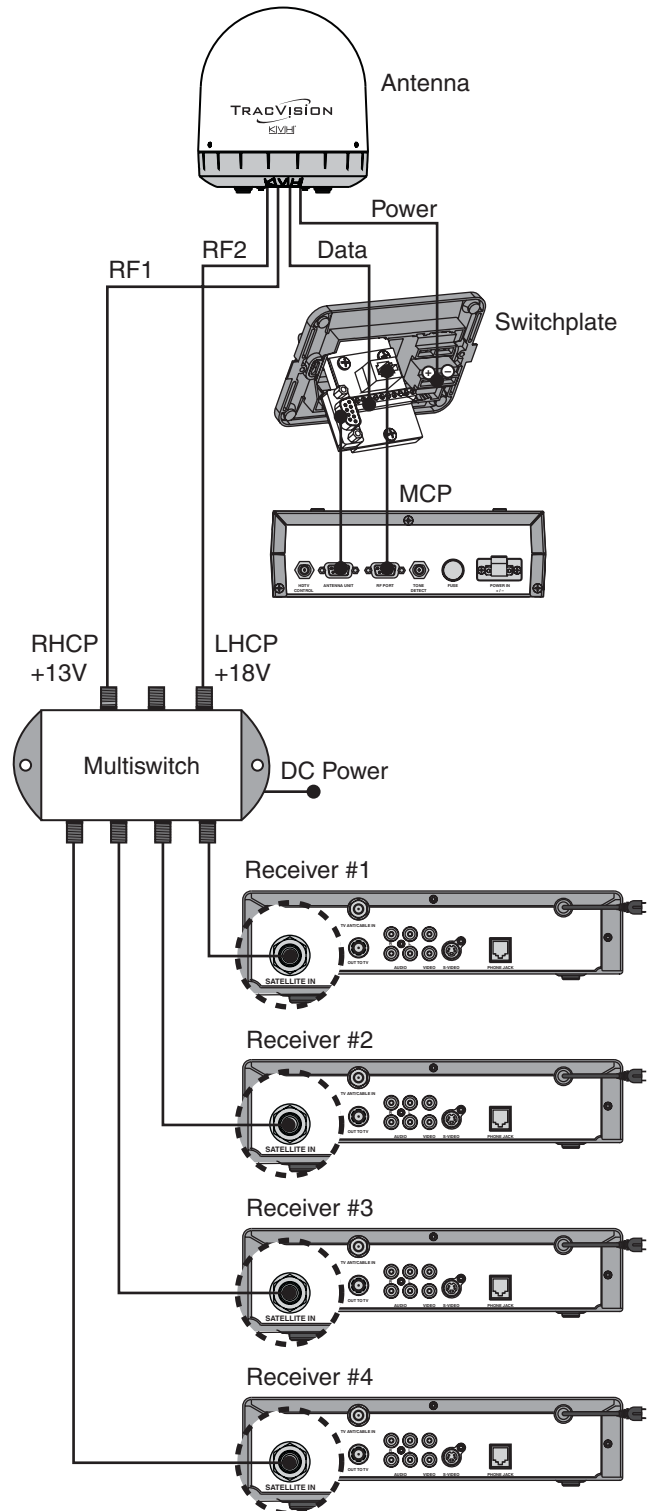

B Continued...

Antenna with Linear Quad LNB

(European systems only)

Follow these steps to connect three or four receivers directly to the antenna.

NOTE: If you need to connect more than four receivers to the TracVision system, install an active multiswitch that generates a 22 KHz tone (such as Spaun model 5602NF - KVH part #19-0413). Connect the multiswitch in accordance with the manufacturer's instructions.

1. Decide which receiver will be the primary receiver. The primary receiver will control satellite selection.

NOTE: The additional receivers will be able to select any channel carried on the satellite that is currently selected on the primary receiver.
2. Connect the RF1 cable from the antenna to the "Satellite In" jack on the primary receiver (see Figure 44).
3. Connect the RF2 cable from the antenna to the "Satellite In" jack on the second receiver.
4. Connect the RF3 cable from the antenna to the "Satellite In" jack on the third receiver.
5. Connect the RF4 cable from the antenna to the "Satellite In" jack on the fourth receiver.

IMPORTANT!

Be sure all receivers are grounded. If the receiver has a 2-prong power plug, run a ground wire from the receiver's chassis to a suitable ground point. If a potential exists between AC and DC grounds, connect the wire to the switchplate's DC return instead.

Figure 44: Receiver Wiring - Antenna with Linear Quad LNB

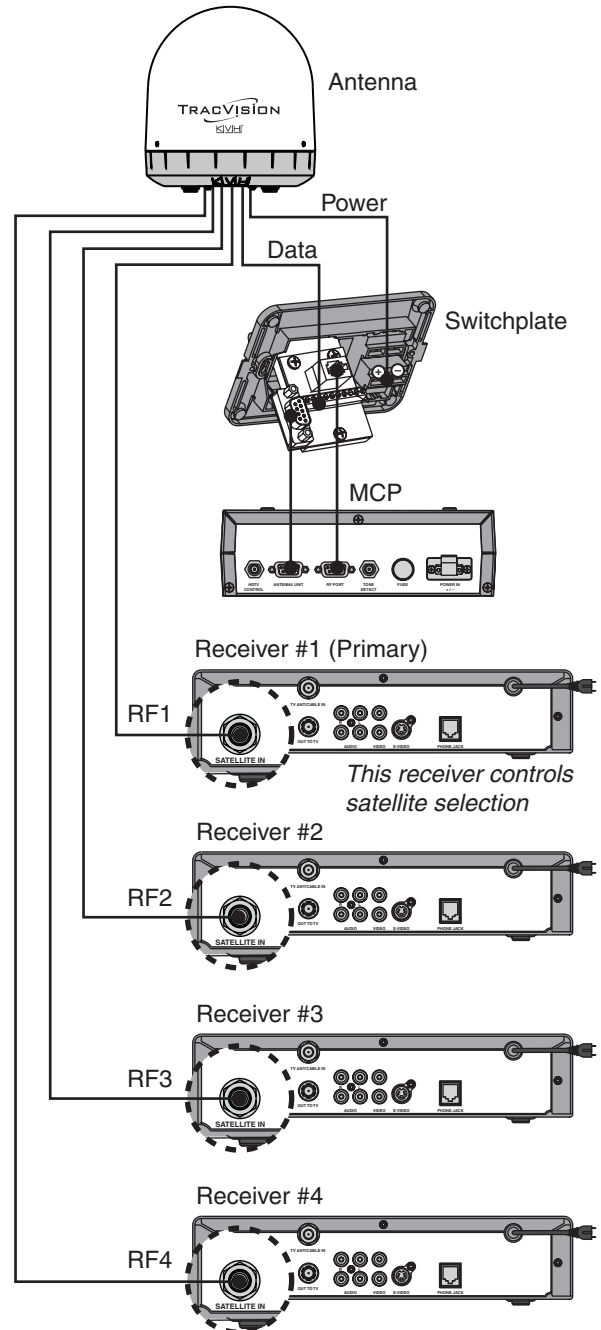

C Selecting a Trisat Group (Linear only)

Appendix

Follow these steps to turn on the system and set it up for one of the three European Trisat groups:

Trisat Group	Satellites
Europe WB	HotbirdWB, Astra1, Astra2S
Europe	Hotbird, Astra1, Astra2S
Scandinavia	HotbirdWB, Sirius, Thor

1. Ensure the antenna has a clear, unobstructed view of the sky.
2. Apply power to the receiver(s), TV(s), and switchplate. Wait two minutes for startup.
3. Press the center **MENU** button on the MCP to access the onscreen menu (see Figure 45).
4. At "Install Satellite?", press **YES**.
5. At "Trisat Mode?", press **YES**.
6. At "USA or Europe?", press **EUROPE**.
7. At "Install Europe WB?", press **NEXT** until the display shows the Trisat group you want to select. Then press **YES**.
8. At "Set Lat/Long?", press **YES**.
9. At "Latitude", use the - and + buttons to set each digit of the vessel's latitude. Press **Enter** to accept each digit.
10. At "Longitude", set the vessel's longitude.
11. At "Trisat skew angle", note the reported skew angle for future reference. Be sure to set the LNB to this skew angle later.
12. Set up the receiver(s) for the same satellites, and in the same order, as the antenna:

Antenna	Receiver	DiSEqC
Sat. A	Alternative 1 or A	DiSEqC 1
Sat. B	Alternative 2 or B	DiSEqC 2
Sat. C	Alternative 3 or C	DiSEqC 3

Figure 45: European Trisat Group Selection Menus on MCP

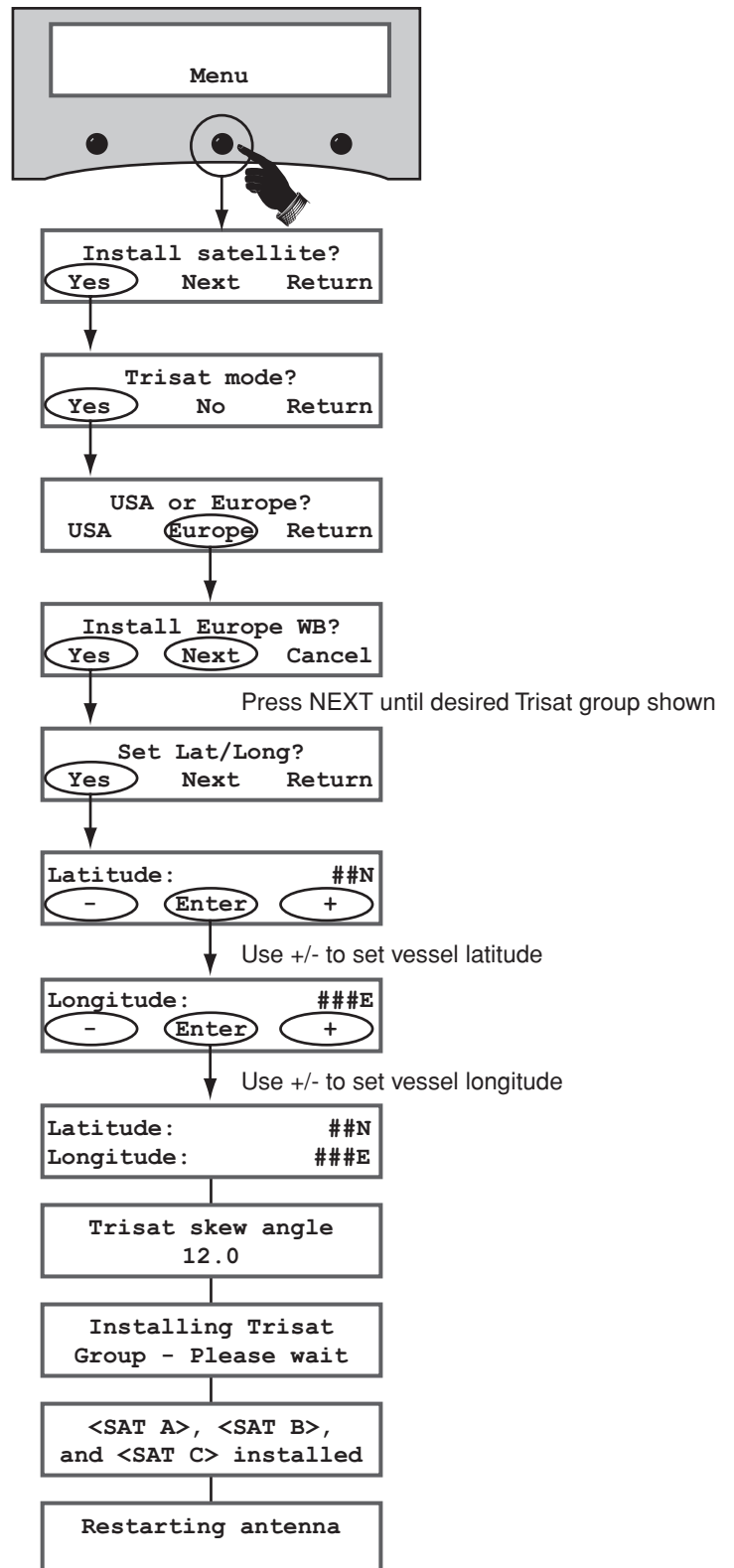

D Satellite Library

Appendix

The TracVision antenna can track a variety of DVB-compatible and DSS (DIRECTV) satellites. Most popular satellites are programmed in the antenna's library (see the table below).

North America

Standard Circular Dual LNB Required

Satellite, Longitude	Name in Library
DIRECTV, 72°W	DSS_72
DIRECTV, 101°W	DSS_101
DIRECTV, 110°W	DSS_110
DIRECTV, 119°W	DSS_119
EchoStar, 61°W	ECHO_61
EchoStar, 110°W	ECHO_110
EchoStar, 119°W	ECHO_119
EchoStar, 148°W	ECHO_148
ExpressVu, 82°W	EXPRESSVU
ExpressVu, 91°W	EXPRESSTV

Asia

Standard Circular Dual LNB Required

Satellite	Name in Library
Asiasat 4, 122.2°E	ASIASAT
Sinosat 1*, 110.5°E	SINOSAT

Latin America

Galaxy Circular Dual LNB Required

Satellite	Name in Library
Galaxy 3C, 95°W	GALAXY3CN

Europe

Linear Dual or Linear Quad LNB Required

Satellite	Name in Library
Astra 1, 19.2°E	ASTRA1
Astra 2N, 28.2°E	ASTRA2N
Astra 2S, 28.2°E	ASTRA2S
Hispasat, 30.0°W	HISPASAT
Hotbird, 13.0°E	HOTBIRD
Hotbird WB, 13.0°E	HOTBIRDWB
Sirius, 5.0°E	SIRIUS
Thor, 0.8°W	THOR
Arabsat, 26°E	ARABSAT
Nilesat, 7°W	NILESAT
Turksat 1C, 42°E	TURKSAT1C
Eutelsat W3A, 7°E	EUTEL_W3A

Mexico

Linear Dual LNB Required

Satellite	Name in Library
PAS 9, 58°W	PAS_9

Australia & New Zealand

Linear Dual LNB Required

Satellite	Name in Library
Optus B1*, 160°E	OPTUS_B1
Optus C1, 156°E	OPTUS_C1

* Special LNB required. Call KVH at 1-401-847-3327.

E User-Defined Satellites

The satellite library in the TracVision antenna includes two slots for user-defined satellites (USER 1 and USER 2). You can program one or both of these library slots for any satellite you wish that is not already set up in the library.

Connect a Laptop to the Antenna

To program your user-defined satellite(s), you first need to connect a Windows® laptop computer to the TracVision system and start Windows HyperTerminal.

TIP: If you are a KVH-authorized technician, you can use the KVH Flash Update Wizard instead of HyperTerminal. Enter commands in the wizard's "Antenna Comms" window. You do not need to flash the antenna to enter commands.

1. Turn off the TracVision antenna.
2. Using the flash adapter cable supplied in the kitpack, connect your laptop to the main flash port (top right stereo jack) on the MCP (see Figure 47).

NOTE: If your computer does not have a DB9 serial COM port, you can use the USB-to-RS232 adapter manufactured by IOGear (IOGear part number GUC232A) or Belkin (Belkin part number F5U109).

3. Open Windows HyperTerminal and establish the following settings for your COM port (see Figure 48):
 - Bits per second: 9600
 - Data bits: 8
 - Parity: None
 - Stop bits: 1
 - Flow control: None

TIP: To view characters on the screen as you type, set up HyperTerminal to echo typed characters. Select "Properties" from the File menu; select "ASCII Setup" at the Settings tab; then select "Echo typed characters locally" at the ASCII Setup window.

Figure 46: Technician Programming the Antenna



Figure 47: Main Flash Port on MCP



Figure 48: HyperTerminal Settings

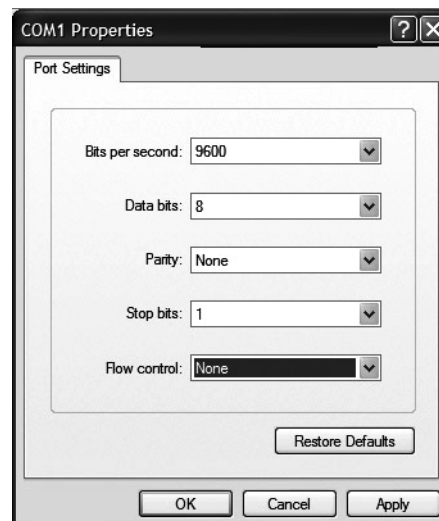

E Continued...

4. Apply power to the TracVision antenna. Data should soon be scrolling in your HyperTerminal window (see Figure 49). If no data appears, check your connections and make sure you're using the correct COM port.
5. Follow the steps in the next section to program the antenna via the HyperTerminal window.

Program Your User-Defined Satellites

To configure a user-defined satellite, you will need to program into the antenna the following information about the satellite (see Figure 50):

- Satellite name
- Satellite longitudinal position
- Transponder information for all combinations of polarization and band:
 - vertical high
 - vertical low
 - horizontal high
 - horizontal low
- OR**
- right
- left
- Frequency
- Symbol rate
- FEC code rate
- Network ID
- Decoder type

NOTE: You can find this satellite information on the web at www.lyngsat.com or www.satcodx.com (neither website is affiliated with KVH).

Figure 49: Antenna Data Scrolling in Window

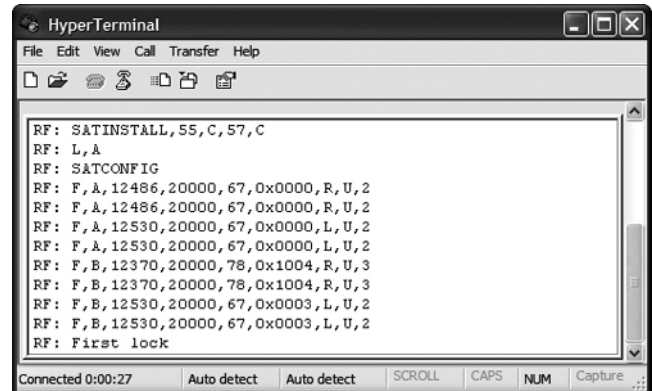
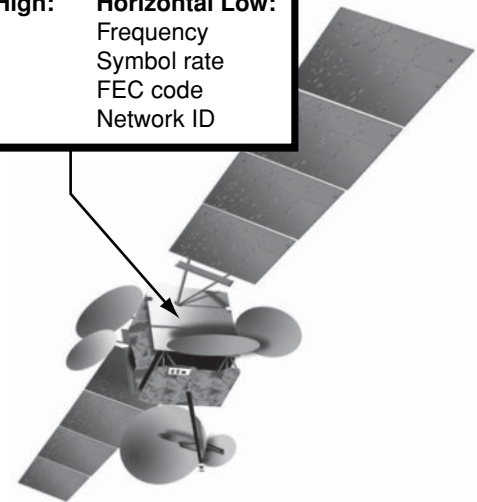

Figure 50: Identifying a Linear Satellite

Name	
Longitude	
Decoder type	
Vertical High:	Vertical Low:
Frequency	Frequency
Symbol rate	Symbol rate
FEC code	FEC code
Network ID	Network ID
Horizontal High:	Horizontal Low:
Frequency	Frequency
Symbol rate	Symbol rate
FEC code	FEC code
Network ID	Network ID



E Continued...

Enter the following commands via Windows HyperTerminal or KVH Flash Update Wizard.

1. Type **HALT** then press Enter.
2. Type **DEBUGON** then press Enter.
3. Type the following **SATCONFIG** command then press Enter. Italics indicate a variable field (see Figure 51 for definitions).

SATCONFIG,USERA,B,C,D,E →

4. Type **@DEBUGON** then press Enter.
5. Type the following **@SATCONFIG** command then press Enter. Italics indicate a variable field (see Figure 52 for definitions).

@SATCONFIG,F,G,H,I,J,K,L,M,N →

6. Repeat Step E5 for each polarization/band:
 - Vertical High • Horizontal High
 - Vertical Low • Horizontal Low

OR

 - Right • Left

If your selected satellite does not have data for one or more of these transponder categories, you can enter the following defaults instead:

Transponder Data	Default Value
Frequency	00000
Symbol rate	27500
FEC code rate	Same value as other transponders
Network ID	0x0000

7. Type **ZAP** then press Enter. The antenna restarts. Wait two minutes for system startup.
8. Follow the instructions in Step 15 on page 17 to select your new USER 1 or USER 2 satellite.

Figure 51: SATCONFIG Command Fields

Field	Description
A	User-defined satellite in library (1=User 1; 2=User 2)
B	Longitude (0-180)
C	E (East) or W (West)
D	Decoding type (2=DSS, 3=DVB)
E	Polarization (C=circular, L=linear)

Figure 52: @SATCONFIG Command Fields

Field	Description
F	User-defined satellite in library (A=User 1; B=User 2)
G	Satellite table # (98=User 1; 99=User 2)
H	Frequency, MHz (00000 or 10700-12750)
I	Symbol rate, kilosymbols per second (01000-45000)
J	FEC code rate (12, 23, 34, 56, 67, or 78)
K	Network ID, hexadecimal (0x####)
L	Polarization (V=vertical; H=horizontal; R=right; L=left)
M	LNB down conversion frequency (L=low [9750 MHz]; H=high [10600 MHz]; G=Galaxy [10500 MHz]; S=Sinosat [11300 MHz]; U=USA [11250 MHz])
N	Decoding type (2=DSS; 3=DVB)

E Continued...

Example - Linear Satellite

The following is an example of programming a linear user-defined satellite (USER 1).

Satellite Name: YOURSAT 123 at 7°W

Transponder Data	Value
<i>Horizontal High</i>	
Frequency	11.966 GHz
Symbol rate	27500
FEC code rate	3/4
Network ID	2048 (dec) = 0x0800
<i>Vertical High</i>	
Frequency	11.823 GHz
Symbol rate	27500
FEC code rate	3/4
Network ID	2048 (dec) = 0x0800
<i>Vertical Low</i>	
No data listed	
<i>Horizontal Low</i>	
No data listed	

Commands you would enter into the antenna via HyperTerminal or KVH Flash Update Wizard:

```

HALT
DEBUGON
SATCONFIG,USER1,7,W,3,L
@DEBUGON
@SATCONFIG,A,98,11966,27500,34,0x0800,H,H,3
@SATCONFIG,A,98,11823,27500,34,0x0800,V,H,3
@SATCONFIG,A,98,00000,27500,34,0x0000,V,L,3
@SATCONFIG,A,98,00000,27500,34,0x0000,H,L,3
ZAP

```

Example - Circular Satellite

The following is an example of programming a circular user-defined satellite (USER 1).

Satellite Name: YOURSAT 456 at 122°W

Transponder Data	Value
<i>Right</i>	
Frequency	12.225 GHz
Symbol rate	20000
FEC code rate	5/6
Network ID	4100 (dec) = 0x1004
<i>Left</i>	
Frequency	12.456 GHz
Symbol rate	20000
FEC code rate	5/6
Network ID	4100 (dec) = 0x1004

Commands you would enter into the antenna via HyperTerminal or KVH Flash Update Wizard:

```

HALT
DEBUGON
SATCONFIG,USER1,122,W,3,C
@DEBUGON
@SATCONFIG,A,98,12225,20000,56,0x1004,R,U,3
@SATCONFIG,A,98,12456,20000,56,0x1004,L,U,3
ZAP

```

F Wiring Diagrams

Appendix

This appendix provides system wiring diagrams for the following receiver configurations:

- One or two receivers
- Three or more receivers (circular)
- Three or more receivers (linear quad)
- One DIRECTV HD receiver
- Two or more DIRECTV HD receivers

IMPORTANT!

The wiring diagrams on the following pages are intended as a quick reference only. Be sure to follow the complete wiring instructions provided earlier in this manual.

F Continued...

Wiring One or Two Receivers*

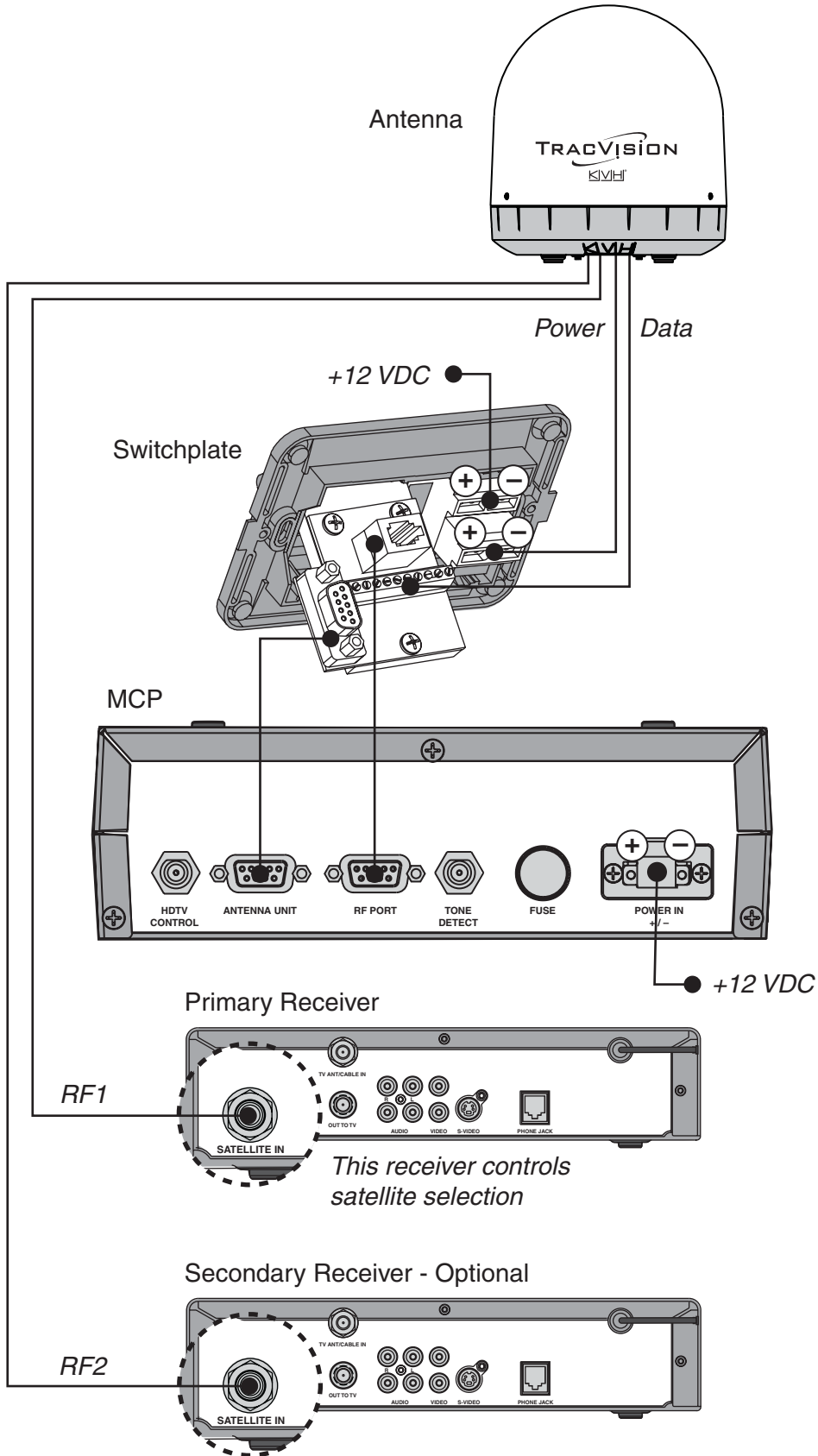

* Does not apply to DIRECTV HDTV

F Continued...

Wiring Three or Four Receivers (Circular)*

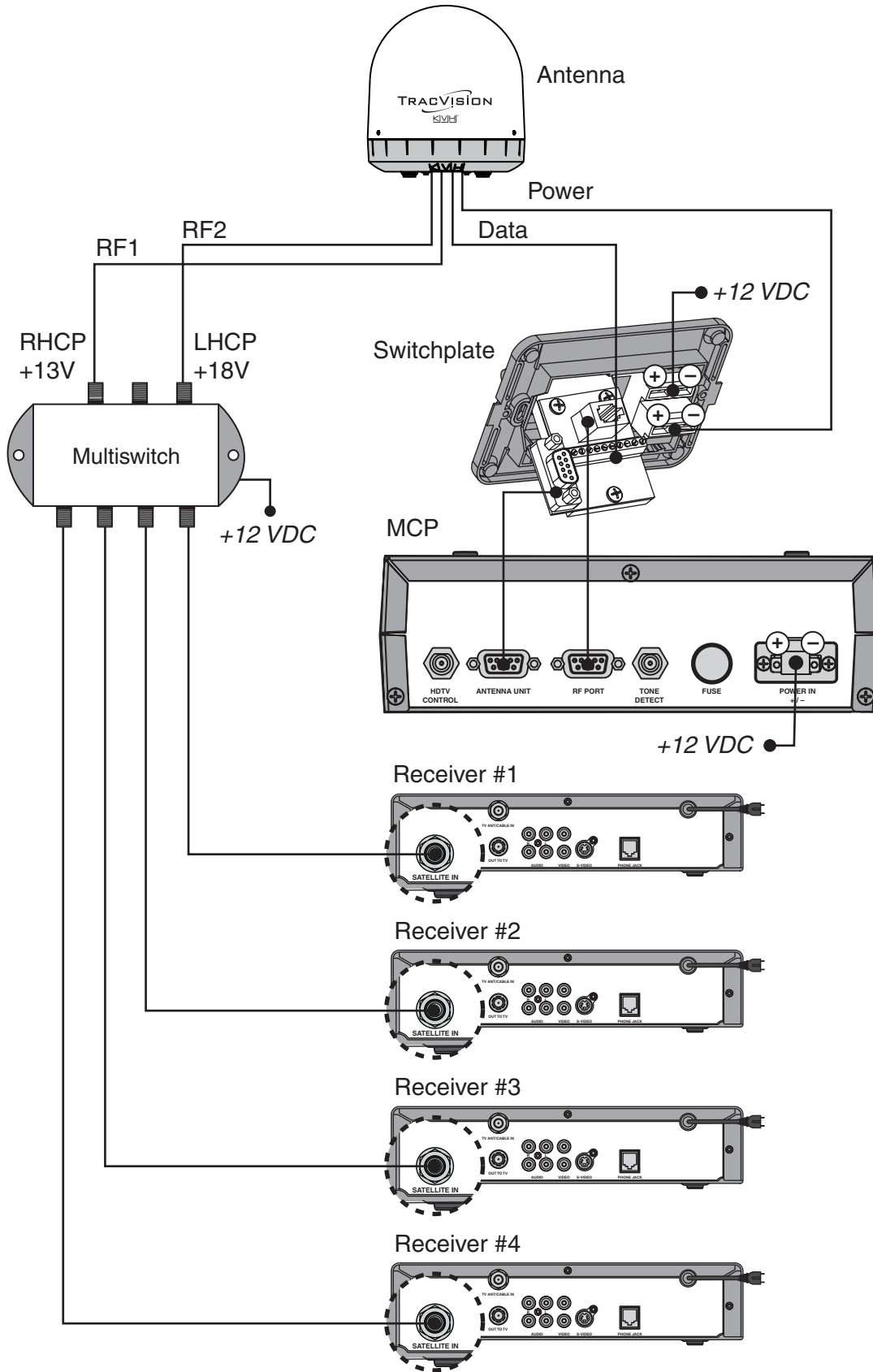

F Continued...

Wiring Three or Four Receivers (Linear Quad)

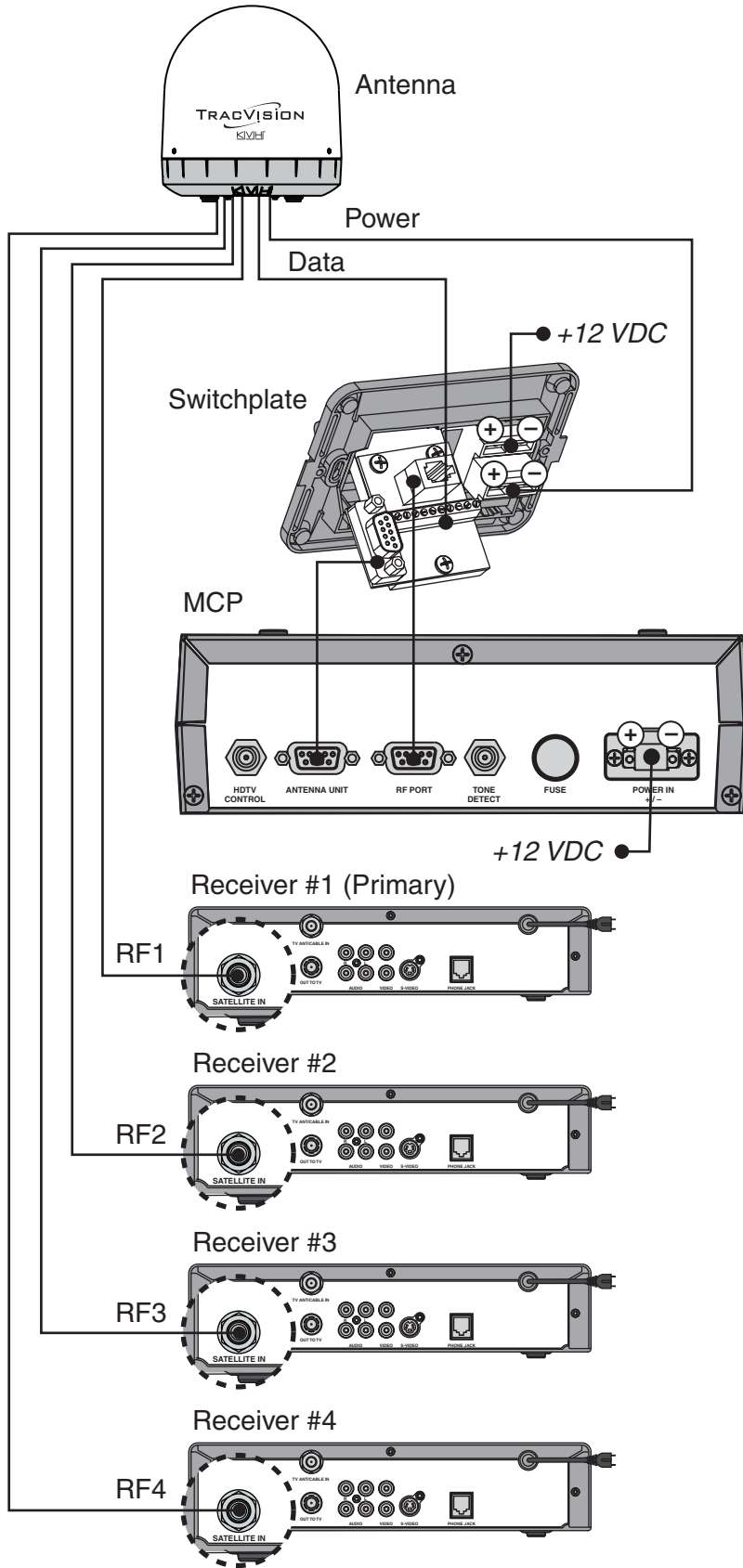

F Continued...

Wiring One DIRECTV HD Receiver

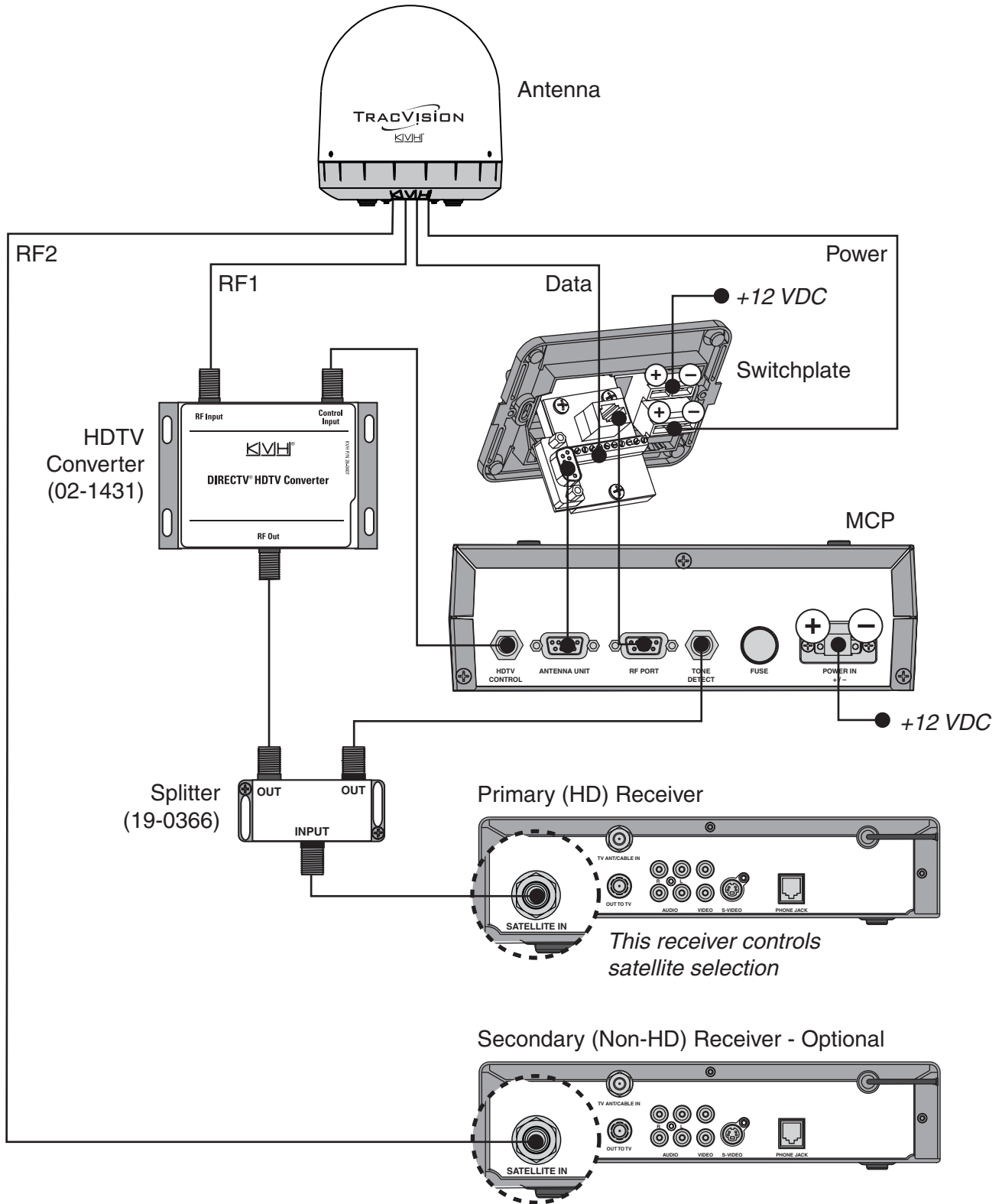

F Continued...

Wiring Two or More DIRECTV HD Receivers

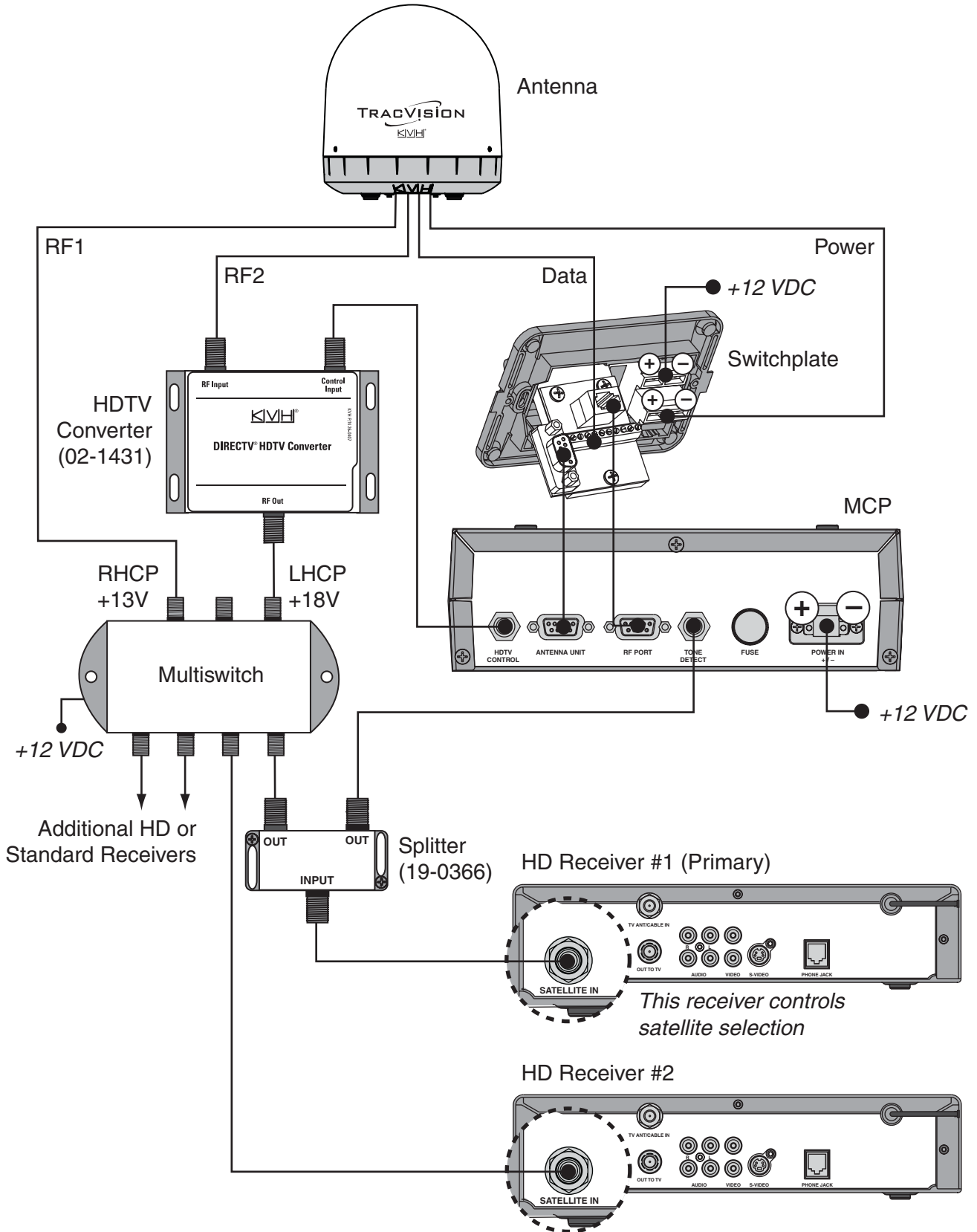

Switchplate Mounting Template

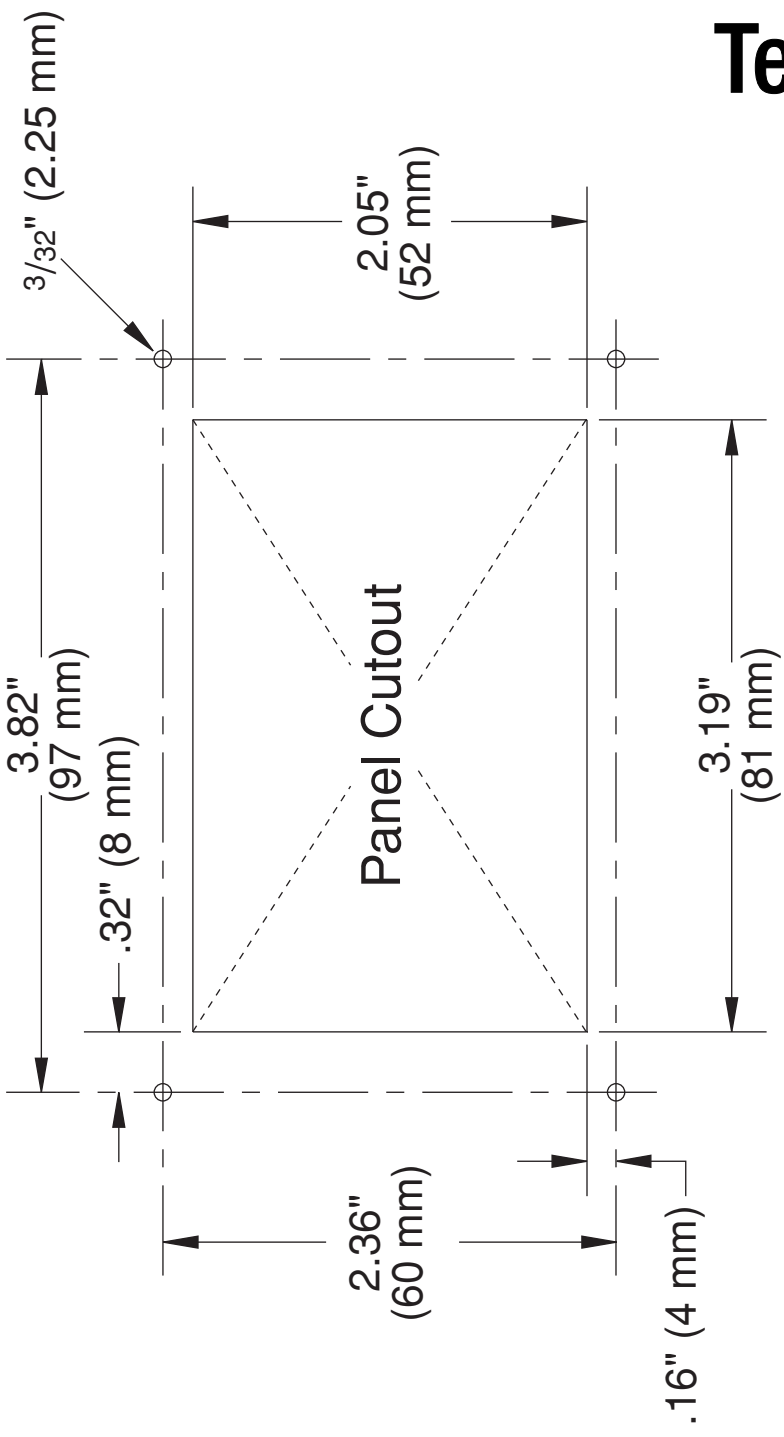

MCP Flush Mounting Template

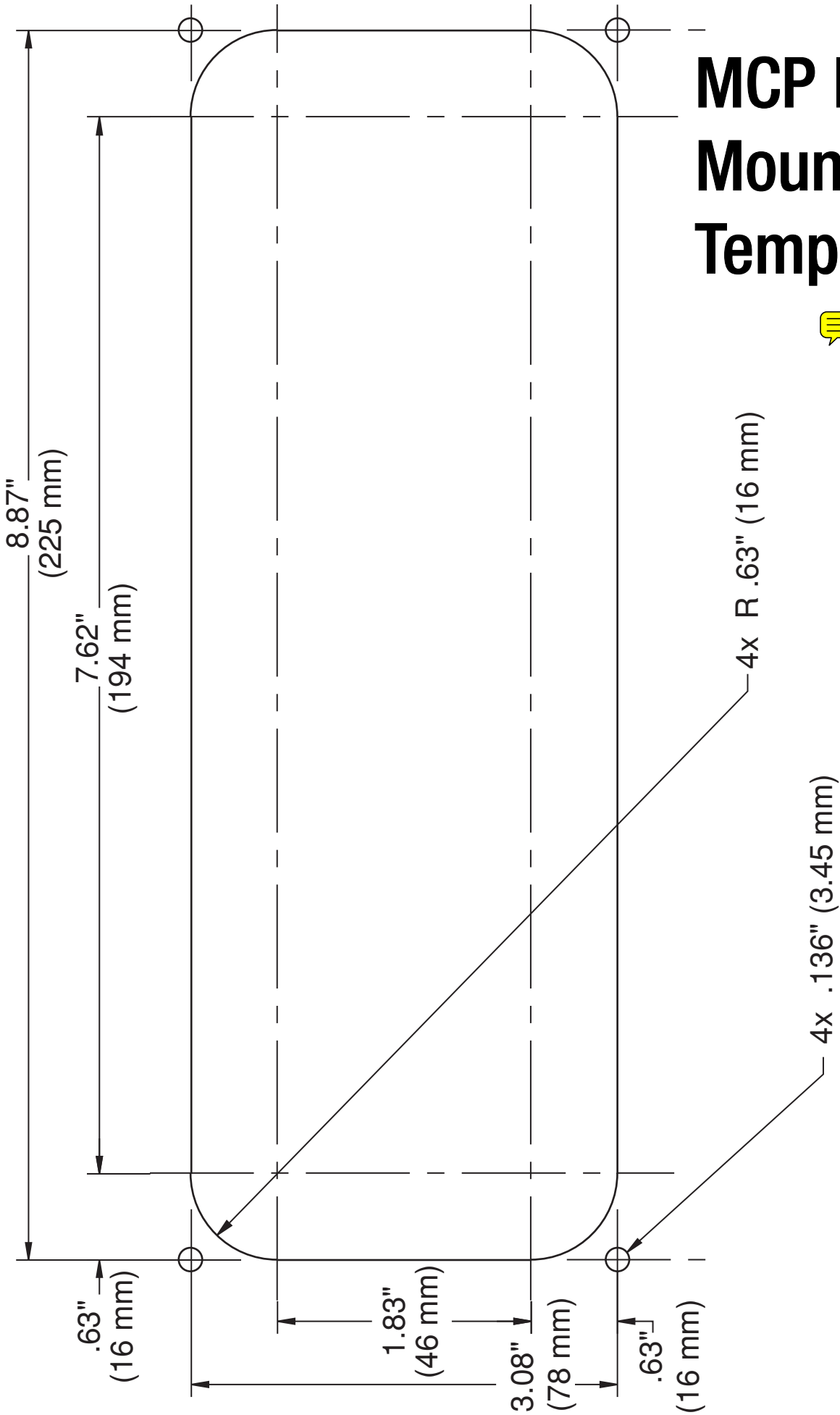



KVH Industries, Inc.

50 Enterprise Center Middletown, RI 02842-5279 U.S.A.
Phone: +1 401 847-3327 Fax: +1 401 849-0045
E-mail: info@kvh.com Internet: www.kvh.com

KVH Europe A/S

Kokkedal Industripark 2B 2980 Kokkedal Denmark
Phone: +45 45 160 180 Fax: +45 45 160 181
E-mail: info@kvh.dk Internet: www.kvh.com