

TRACVISION[®]
BY KVH INDUSTRIES

TracVision M5

GyroTrac™ Configuration



TracVision M5 Installation Guide

TracVision M5 Installation Guide

GyroTrac Configuration

These instructions explain how to install the TracVision M5 satellite TV antenna system on a vessel. Complete instructions on how to use the system are provided in the *User's Guide*.

Installation Steps

1. Inspect Parts and Get Tools, 3
2. Plan the Antenna Installation, 4
3. Plan the Sensor Installation, 5
4. Plan the ADCU Installation, 6
5. Prepare the Antenna Site, 7
6. Remove the Restraints, 8
7. Wire the Antenna, 9
8. Mount the Antenna, 10
9. Mount the Sensor, 11
10. Wire the Receiver(s), 13
11. Wire the ADCU, 15
12. Connect Power, 16
13. Mount the ADCU, 17
14. Select Satellites, 18
15. Enter Your Latitude & Longitude, 21
16. Get the LNB Skew Angle, 22
17. Set the LNB Skew Angle, 23
18. Run Two Check Switch Tests, 24
19. Calibrate the Sensor, 25
20. Educate the Customer, 27

Who Should Install the System?

To ensure a safe and effective installation, KVH recommends that a KVH-authorized marine technician install the TracVision antenna. KVH-authorized technicians have the tools and electronics expertise necessary to install the system. To find a technician near you, visit www.kvh.com/wheretogetservice.

Linear vs. Circular Systems

The installation process differs slightly depending on the type of LNB (low noise block) that is installed in the antenna (linear or circular). These differences are noted throughout this manual. Appendix C on page 34 notes the satellites available for each LNB type and geographic region.

Technical Support

If you need technical assistance, please contact KVH Technical Support:

North/South America, Australia:
Phone: +1 401 847-3327
E-mail: techs@kvh.com

Europe, Middle East, Asia:
Phone: +45 45 160 180
E-mail: support@kvh.dk

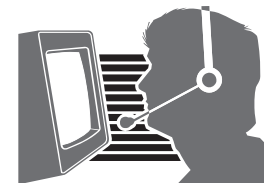

1 Inspect Parts and Get Tools

Before you begin, follow these steps to make sure you have everything you need to complete the installation.

- a. Unpack the box and ensure it contains everything shown on the *Kitpack Contents List*. Save the packaging for future use.

IMPORTANT!

Always lift the antenna by the baseplate and never by the radome or any portion of the internal antenna assembly (see Figure 1).

- b. Carefully examine all of the supplied parts to ensure nothing was damaged in shipment.
- c. Gather all of the tools and materials listed below. You will need these items to complete the installation.
 - Flat-head and Phillips-head screwdrivers
 - Electric drill and 3/8" (10 mm), 1/8" (3.5 mm), and #29 drill bits
 - 3" (80 mm) hole saw
 - Socket wrenches and 7/16" open-end wrench
 - Torque wrench (*Linear systems only*)
 - Light hammer and center punch
 - Adhesive tape and scribe or pencil
 - Wire strippers and terminal lug crimper
 - 2 mm allen hex key (*Linear systems only*)
 - RG-6 or RG-11 RF coax cable(s) with Snap-N-Seal® F-connectors; see Step 7a on page 9 for quantity and type required)
 - Augat IT1000 connector installation tool (KVH part #19-0242)
 - Power cable for connecting power to the ADCU (see Figure 2)
 - Satellite TV receiver and TV (see Figure 3 for a list of validated U.S./Canadian receivers)
 - If you need to configure the system for Tri-Sat mode: Windows® laptop PC with Windows HyperTerminal (or equivalent) or KVH Flash Update Wizard installed

Figure 1: TracVision M5 System Components

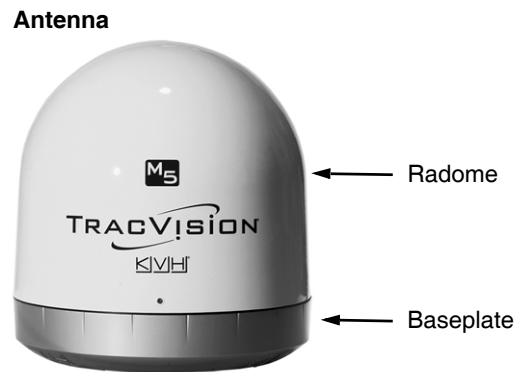

GyroTrac Sensor



ADCU (Advanced Digital Control Unit)



Figure 2: Guidelines for Power Cable

Cable Length	Use Cable Gauge
< 40 ft (12 m)	14AWG (2.5mm ²)
40-70 ft (12-21 m)	12AWG (4mm ²)

Figure 3: KVH-Validated U.S./Canadian Receivers

Standard-Definition Models		
DIRECTV	DISH Network	ExpressVu
D12	311	4100
D11		3100
D10		
High-Definition (HD) Models		
DIRECTV	DISH Network	ExpressVu
H21*	211k	6100
H20*	211	

* For compatibility with a Tri-Sat AutoSwitch Kit (KVH part #72-0301-07), use model H21-200 or H20-600.

2 Plan the Antenna Installation

Consider the following antenna installation guidelines:

- Minimize blockage. The antenna requires a clear view of the sky to receive satellite TV (see Figure 4). The fewer obstructions, the better the system will perform.
- Make sure the mounting surface is wide enough to accommodate the antenna's base (see Figure 5). Also make sure it is flat, level (within $\pm 1^\circ$), strong enough to support the antenna's weight (30 lbs, 13.6 kg), and rigid enough to withstand vibration.
- Select a location that is as close as possible to the intersection of the vessel's fore-and-aft centerline and midships.
- Do not mount the antenna at the same level as the radar because the radar's energy might overload the antenna. Ideally, you should mount the antenna 4 ft (1.2 m) above the radar, outside the beam path of the radar.

Figure 4: Blockage from Obstruction

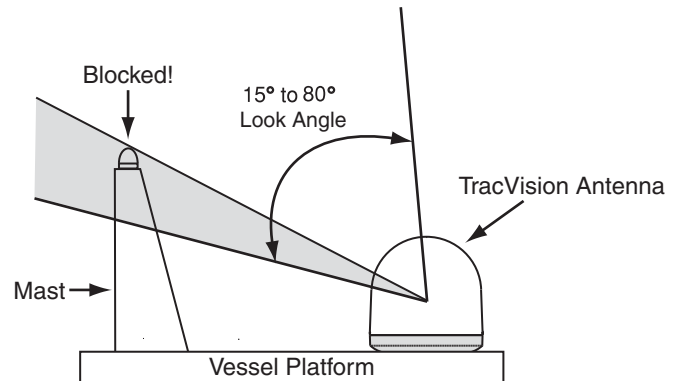
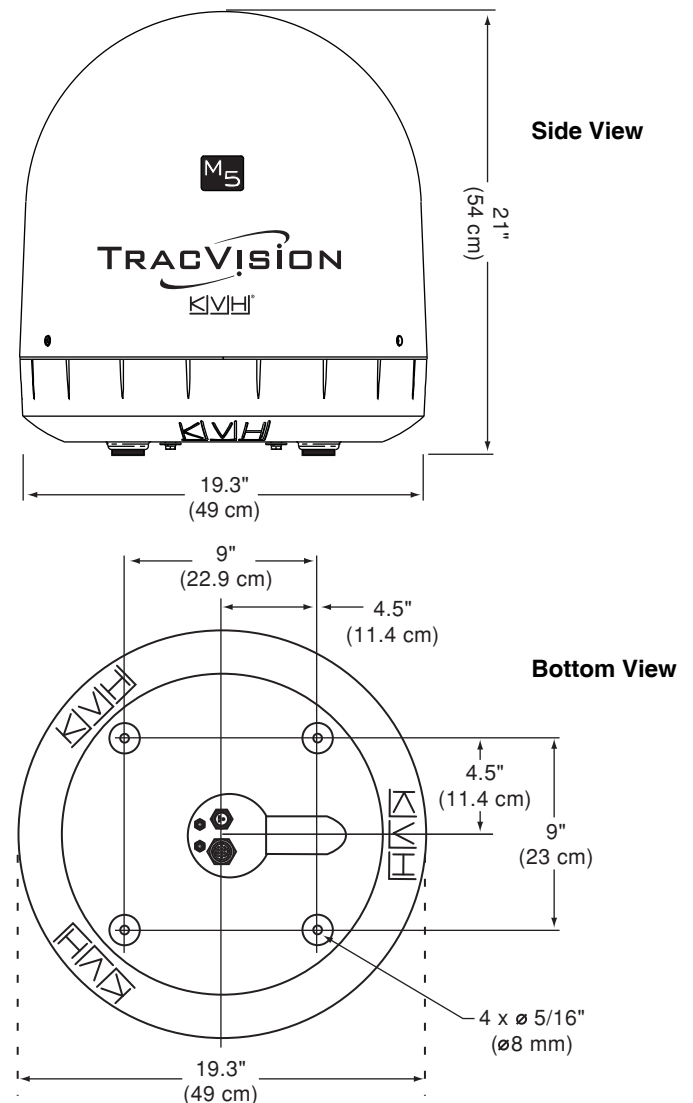

Figure 5: Antenna Dimensions



3 Plan the Sensor Installation

Consider the following GyroTrac sensor installation guidelines:

- Select a sensor mounting location in a dry area belowdecks as low as possible in the center of the vessel. Do not mount the sensor in a bilge.
- Make sure the mounting surface does not flex and is rigid enough to withstand vibration.
- Select a location that is at least 4 ft (1.2 m) away from any magnetized materials, large ferrous masses, cranes, derricks, antennas, devices with DC motors, CRT monitors, loudspeakers, electric winches, high-ampere cables, or battery banks. The sensor performs best in a benign magnetic environment.
- If you need to fabricate custom mounting brackets, be sure to make them from a non-ferrous material, such as wood, brass, aluminum, fiberglass, or plastic. Also be sure to use stainless steel bolts or nails.
- If you are mounting the sensor on a steel vessel, enclose the sensor in a fiberglass container and use an aluminum, brass, plastic, or wood platform (NOT steel or iron) to position the sensor at least 4 ft (1.2 m) above and 6 ft (1.8 m) away from the steel surface.

Figure 6: GyroTrac Sensor Dimensions

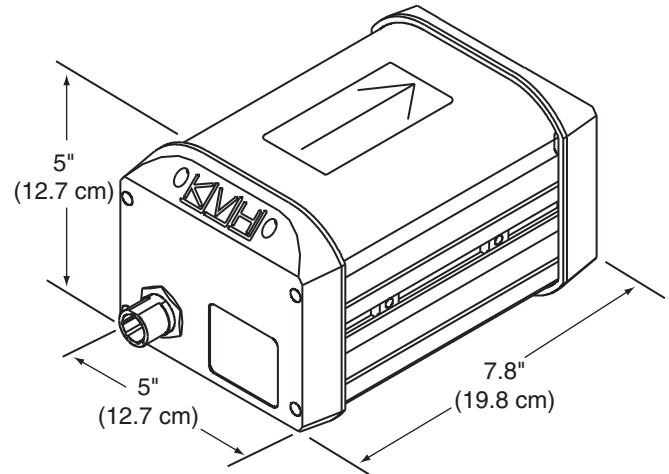

4 Plan the ADCU Installation

Consider the following ADCU installation guidelines:

- Select an ADCU mounting location in a dry, well-ventilated area belowdecks, away from any heat sources or salt spray.
- Be sure the ADCU's front panel will be easily accessible to the user.
- Be sure to leave enough room at the ADCU's rear panel for connecting the cables (see Figure 7 for ADCU dimensions).
- Consider the lengths of the connecting cables. The ADCU must be located close enough to the antenna and the GyroTrac sensor so that you can connect the supplied cables, while allowing adequate slack for a service loop. The antenna data cable is 50 ft (15 m); the GyroTrac sensor cable is 30 ft (9 m).
- **(Circular and Sky Mexico only)** The grounding block should be located within 45 ft (13 m) of the antenna, within 5 ft (1.5 m) of the primary receiver, and within 25 ft (7.6 m) of a suitable vessel AC ground.
- The kitpack contains parts for mounting the ADCU either to a horizontal surface (using Velcro) or to a vertical surface (using the supplied flush mount bracket).

Prepare the ADCU Mounting Site (Flush Mount only)

NOTE: Skip this step if you plan to mount the ADCU to a horizontal surface instead; proceed to page 7.

- Using the ADCU flush mounting template provided at the end of this manual, mark and cut out a hole in the mounting surface to accommodate the flush mount bracket (see Figure 8).
- Using the same template, mark the locations for the four ADCU mounting holes.
- Using a #29 drill bit, drill a 0.136" (3.45 mm) hole at the four mounting hole locations. Later, you will mount the ADCU using four #8 screws.

Figure 7: ADCU Dimensions

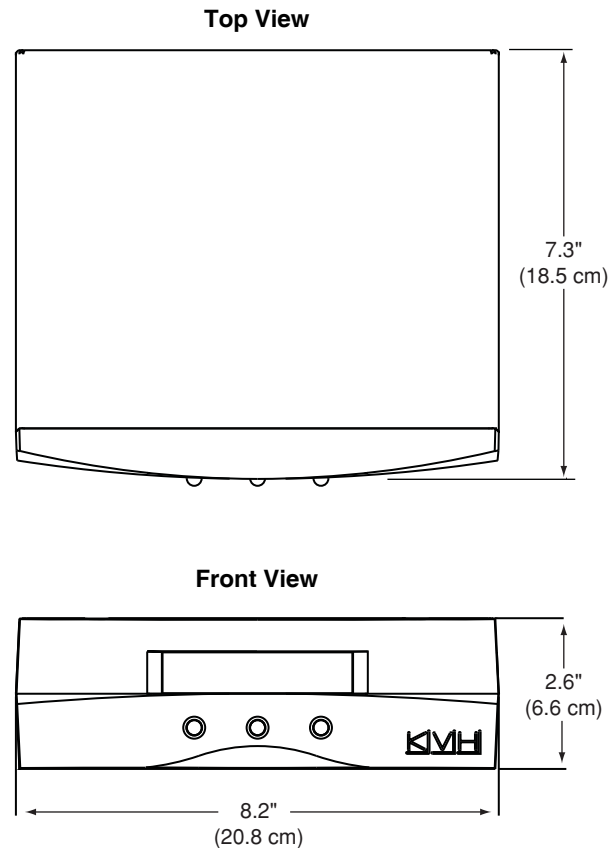
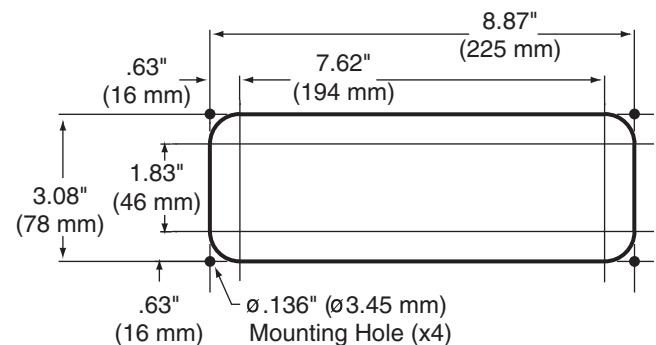

Figure 8: ADCU Mounting Holes Layout



5 Prepare the Antenna Site

Once you have identified a suitable antenna mounting site, according to the guidelines provided on page 4, follow these steps to drill the mounting holes and cable access hole to prepare the site for installation.

- a. Unfold the antenna mounting template (supplied in the Customer Welcome Kit) and place it onto the mounting surface. Make sure the “FWD” (forward) arrow points toward the bow and is parallel to the vessel’s centerline (see Figure 9).

NOTE: You don’t need to mount the antenna exactly on the vessel’s centerline (the closer, the better), but the antenna’s forward arrow must be parallel to it.

- b. Using a light hammer and center punch, mark the locations for the four mounting holes and cable access hole on the mounting surface in the locations indicated on the template.
- c. Drill a 3/8" (10 mm) hole at the four mounting hole locations you marked in Step b. Later, you will insert four 1/4"-20 bolts through these holes to secure the antenna to the mounting surface.
- d. Cut out the 3" (80 mm) cable access hole in the location you marked in Step b. Smooth the edges of the hole to protect the cables. Later, you will route the data, power, and RF cables through this hole and into the vessel.
- e. Clean and dry the antenna mounting surface.
- f. Peel off the paper backing from the supplied foam seal to expose the adhesive. Then press the foam seal down firmly onto the mounting surface, ensuring the narrow end points toward the bow and the hole in the foam seal aligns with the cable access hole in the mounting surface (see Figure 10).

NOTE: Apply the foam seal to the vessel mounting surface, not to the antenna’s baseplate. You will have difficulty connecting the cables to the antenna if the foam seal is attached to the baseplate.

Figure 9: Antenna Mounting Holes Layout

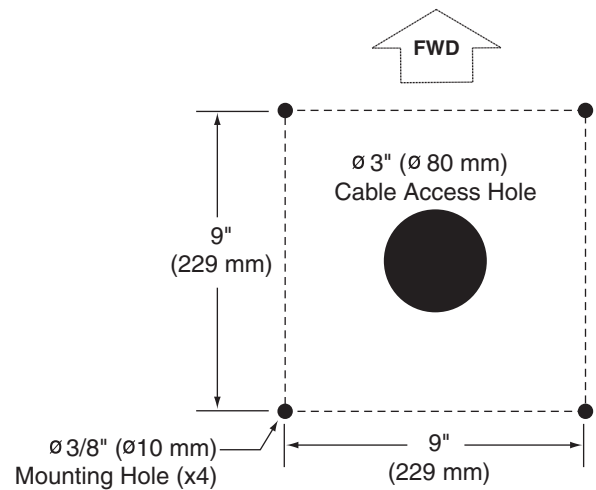

Figure 10: Foam Seal



6 Remove the Restraints

Inside the antenna, a foam block and two bolts prevent the antenna assembly from moving during shipment. Follow these steps to remove these shipping restraints.

- a. Remove the three #10-24 Phillips screws securing the radome to the baseplate. Carefully lift the radome straight up until clear of the antenna assembly and set it aside in a safe place.

TIP: If you keep the radome topside, secure it with a lanyard to prevent it from falling overboard.

- b. Remove the foam block that is wedged beneath the antenna's reflector (see Figure 11). Save this restraint for future use; the customer will need to reinstall it if he/she needs to relocate or reship the antenna.
- c. Using a 10 mm socket wrench, remove the two bolts, washers, and spacers securing the antenna assembly to the baseplate (see Figure 12 and Figure 13). Save these restraints for future use.

IMPORTANT!

Once you have removed the restraints, keep the antenna level as much as possible and handle the antenna very carefully. Prevent the internal antenna assembly from rotating freely within the baseplate to avoid damaging the limit switch.

Figure 11: Foam Block Shipping Restraint

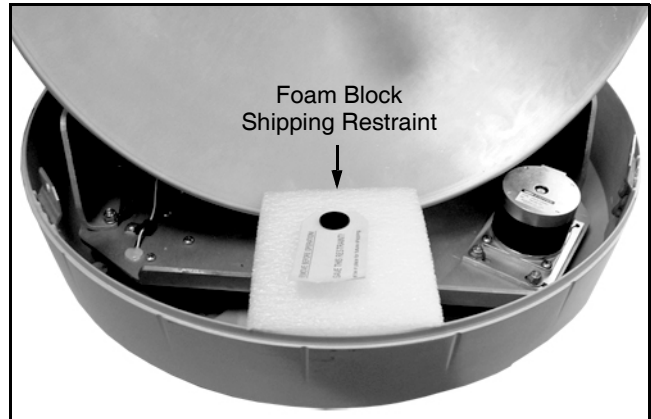

Figure 12: Shipping Restraint Hardware

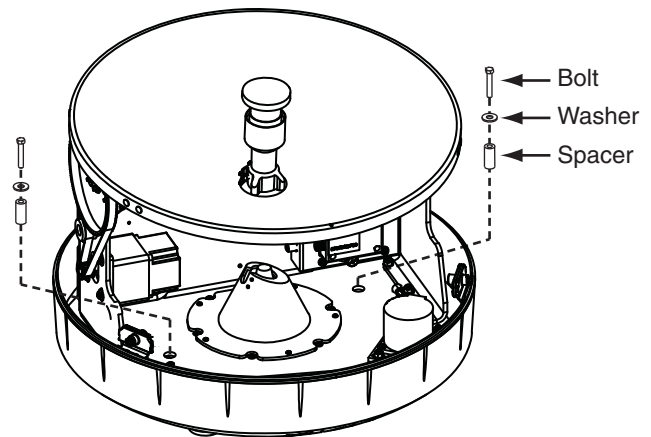
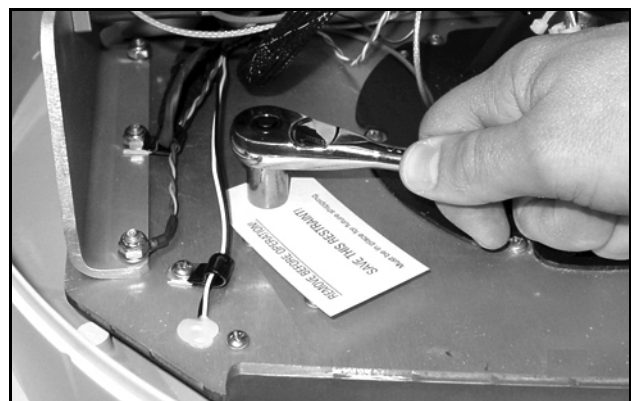

Figure 13: Removing the Shipping Restraint Bolts



7 Wire the Antenna

Follow these steps to connect the data, power, and RF cables to the antenna.

- a. First determine the number of RF coax cables you need to connect to the antenna for your particular installation. If you wish to connect just one satellite TV receiver to the TracVision system, you need to connect just one RF cable to the antenna. If you wish to connect two or more receivers to the system, you will need to connect two RF cables. (See Figure 14 to determine the type of cable required.)
- b. Route the data, power, and RF cables belowdecks through the 3" (80 mm) cable access hole. Leave an adequate service loop, approximately 8" (20 cm) of slack, in the cables for easy serviceability. Later, you will connect the data cable to the ADCU, the power cable to vessel power, and the RF cable(s) to the receiver(s).
- c. Connect the data cable to the "Data" connector on the bottom of the antenna (see Figure 15 and Figure 16). Hand-tighten until the cable locks in place; do not use excessive force.
- d. Connect the power cable to the "Power" connector on the bottom of the antenna. Hand-tighten until the cable locks in place; do not use excessive force.
- e. Connect an RF coax cable to the "RF1" connector on the bottom of the antenna. Hand-tighten, then tighten with a 7/16" wrench for 1/4 turn to ensure an electrical and weather-proof connection.
- f. If you wish to connect two or more receivers, connect a second RF coax cable to the "RF2" connector on the bottom of the antenna. Label both RF cables to match the antenna connectors so that you can easily identify the cables later.

Figure 14: RF Cable Guidelines

Cable Length	Use Cable Type
<= 75 ft (23 m)	RG-6
> 75 ft (23 m)	RG-11

Figure 15: Connectors on Bottom of Antenna

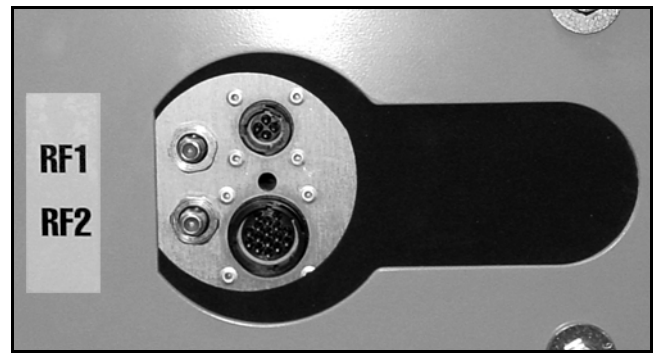
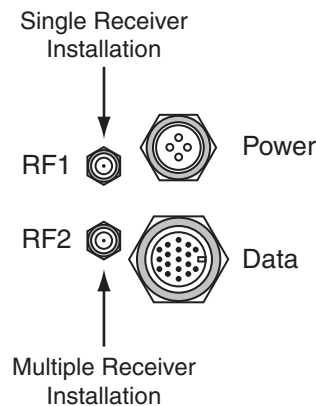

Figure 16: Antenna Cable Connections



8 Mount the Antenna

Follow these steps to mount the antenna to the mounting surface.

- a. Place the antenna baseplate over the holes drilled in the mounting surface. Ensure the "Forward" arrow inside the baseplate points toward the bow and is parallel to the vessel's centerline (see Figure 17).
- b. Make sure the four holes in the baseplate line up with the four holes in the mounting surface.

IMPORTANT!

You will need to rotate the antenna assembly by hand to see all four mounting holes. Rotate the antenna assembly slowly. If it hits a mechanical stop with excessive force, the limit switch might become damaged.

- c. At each of the four baseplate mounting holes, place a 1/4" flat washer on a 1/4"-20 bolt and insert the bolt into the hole from above (see Figure 18).
- d. Secure each mounting bolt to the mounting surface using a 1/4" flat washer and a 1/4"-20 lock nut from below. Tighten all four bolts until the four rubber feet are bottomed against the mounting surface and the foam seal is fully compressed.

TIP: If you are installing a linear system, keep the radome off for now. You will need to adjust the skew angle of the antenna's LNB.

- e. Reinstall the radome onto the antenna. Secure in place with the three #10-24 screws you removed in Step 6 (see Figure 19).
- f. Install a protective plastic screw cap (supplied in the kitpack) over each radome screw.

Figure 17: "Forward" Arrow in Antenna Baseplate

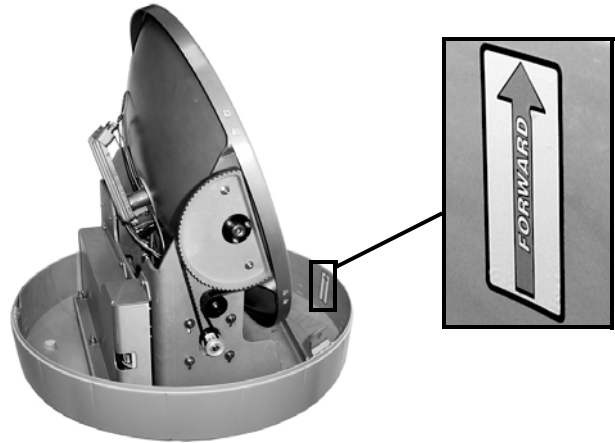

Figure 18: Mounting the Antenna (Side View)

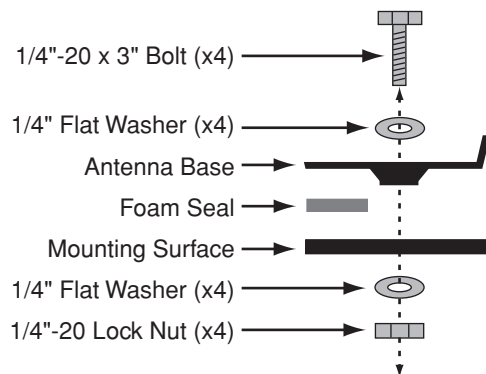
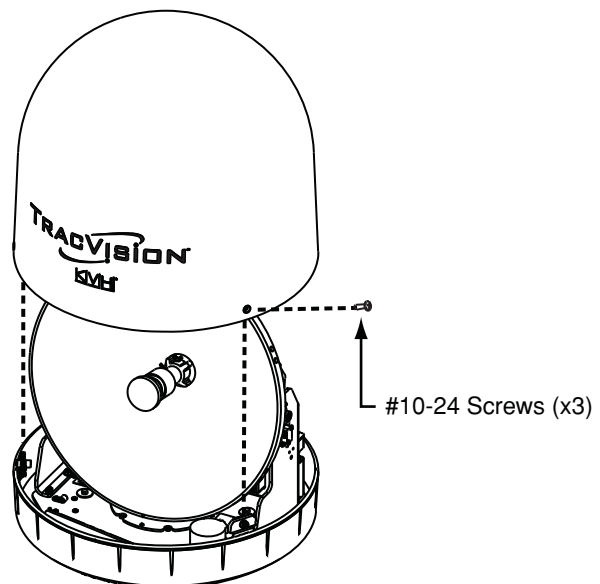

Figure 19: Installing the Radome



9 Mount the Sensor

In Step 3, you identified a suitable GyroTrac sensor mounting location. Now follow these steps to mount the GyroTrac using one of the following options:

Option 1 - Mount to a horizontal surface

Option 2 - Mount to a vertical surface

IMPORTANT!

If you are unable to mount the sensor exactly level, you can enter offset values into the system later to compensate for a minor misalignment. See Appendix E on page 42 for details.

Option 1 - Mount to a Horizontal Surface

- Position the sensor on the mounting surface so that its forward ("FWD") reference points toward the bow and is parallel to the vessel's centerline within $\pm 5^\circ$ (see Figure 20).
- Place the horizontal bracket on the mounting surface and align it in the same manner as the sensor.
- Using the holes in the bracket's mounting feet as a template, drill four 1/8" (3.5 mm) holes in the mounting surface. Later, you will attach the bracket to the mounting surface at these four holes.
- At each of the four mounting feet, insert a #8 fiber washer from above, and insert a #8 fiber washer from below (see Figure 21). *The fiber washers will isolate the sensor from ground.*
- Secure the horizontal bracket to the mounting surface using four #8 screws and flat washers.
- Place the sensor onto the bracket. Make sure the sensor's forward ("FWD") reference points toward the bow and its "Up" arrow points upward.
- Secure the sensor to the horizontal bracket using four #10-32 screws, lock washers, and flat washers. Insert the screws into the four T-nuts held within the sensor's housing track.

Figure 20: Sensor Alignment

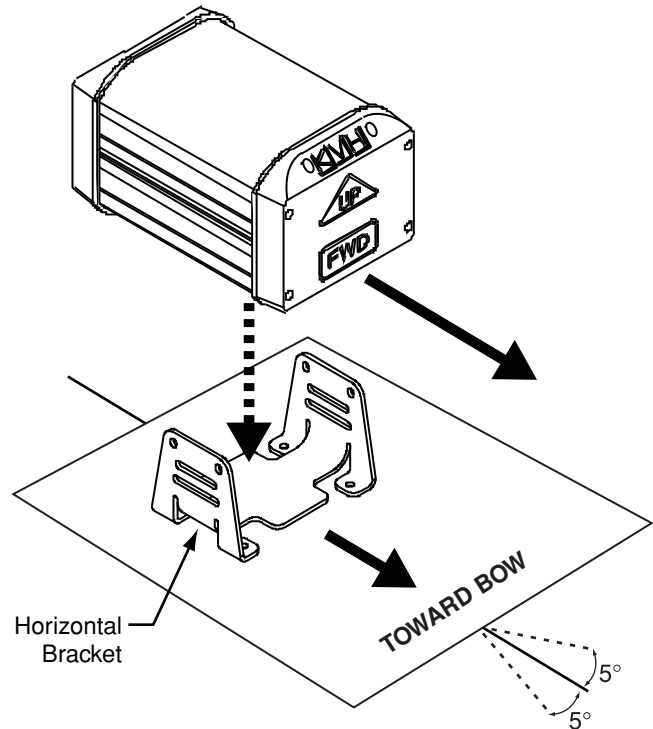
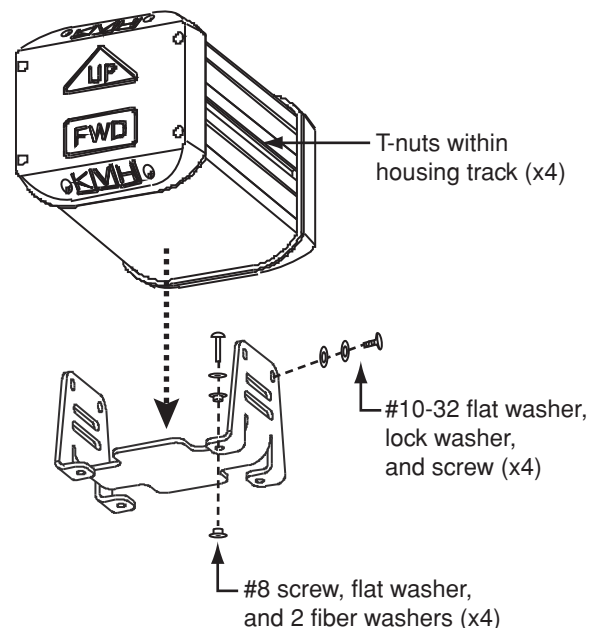

Figure 21: Sensor Mounting to a Horizontal Surface



9 Continued Mount the Sensor

Option 2 - Mount to a Vertical Surface

- The vertical bracket allows you to mount the sensor (within its horizontal bracket) either perpendicular or parallel to the mounting surface (see Figure 22). Be sure to orient the vertical and horizontal brackets so that the sensor's forward ("FWD") reference will point toward the bow and will be parallel to the vessel's centerline within $\pm 5^\circ$ (see Figure 20 on page 11). Also make sure the sensor will be level with the deck.
- Using the holes in the vertical bracket's mounting feet as a template, drill four 1/8" (3.5 mm) holes in the mounting surface.
- Secure the vertical bracket to the mounting surface using four #8 screws and flat washers (see Figure 23).
- Secure the horizontal bracket to the vertical bracket using four #8 screws, eight flat washers, eight fiber washers, and four self-locking nuts (see Figure 23). *The fiber washers will isolate the sensor from ground.*
- Place the sensor onto the horizontal bracket (see Figure 24). Make sure the sensor's forward ("FWD") reference points toward the bow and its "Up" arrow points upward.
- Secure the sensor to the horizontal bracket using four #10-32 screws, lock washers, and flat washers. Insert the screws into the four T-nuts held within the sensor's housing track.

Figure 22: Bracket Orientation Options

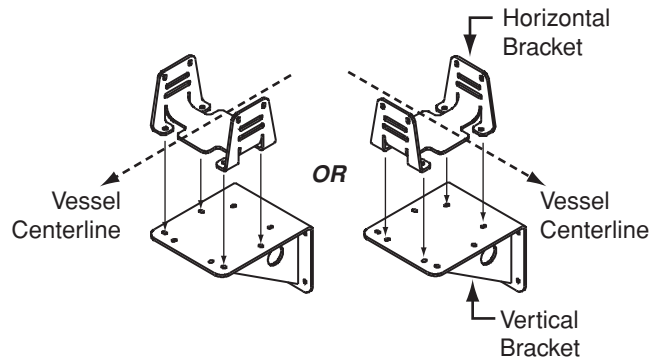

Figure 23: Bracket Mounting

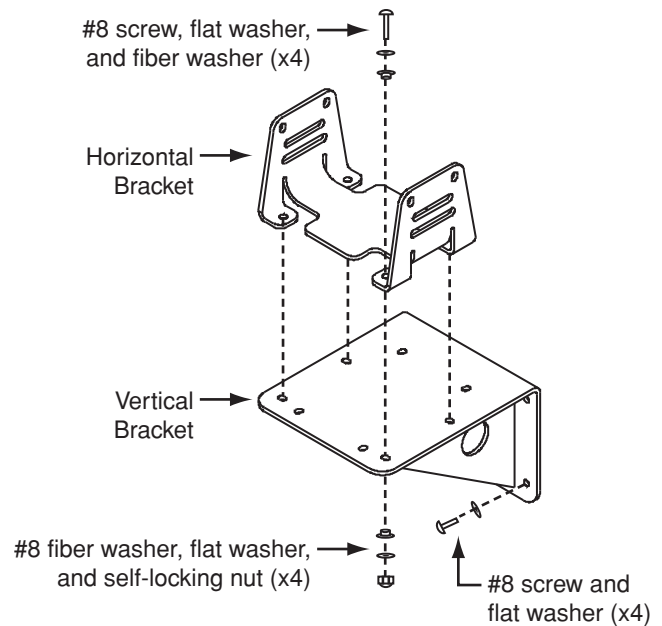
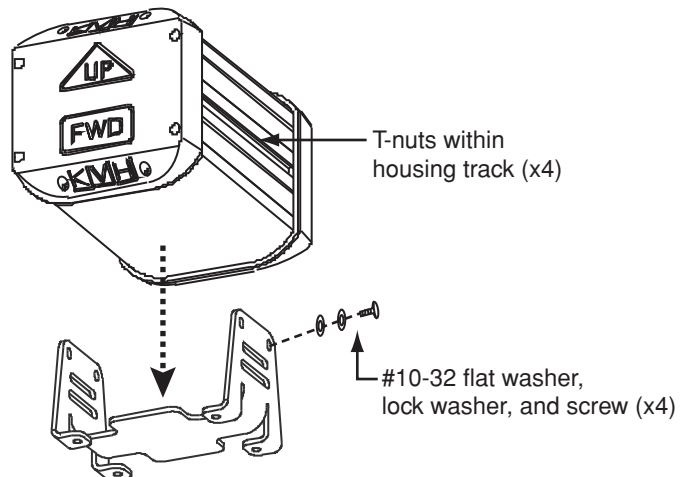

Figure 24: Sensor Mounting to a Vertical Surface



10 Wire the Receiver(s)

Circular and Sky Mexico Systems

If you are installing a **circular** system, or a linear system for **Sky Mexico**, follow these steps to connect the customer's satellite TV receiver(s) to the TracVision system.

TIP: For DIRECTV Ku-band Tri-Sat service, you will need to install the KVH Tri-Sat AutoSwitch Kit (KVH part #72-0301-07).

- Connect the RF1 cable from the antenna to the grounding block, as shown in Figure 25. Label this grounding block connector "RF1."
- If you are connecting multiple receivers, connect the RF2 cable from the antenna to the grounding block. Label this connector "RF2."
- Attach the supplied ground wire to either ground screw on the grounding block. Connect the other end of the wire to a suitable vessel AC ground.
- Using the two #6 screws supplied with the grounding block, mount the grounding block inside the vessel.

IMPORTANT!

If you wish to connect **three or more** receivers to the antenna, see Appendix A on page 31 (circular) or page 32 (Sky Mexico).

- If you are connecting two receivers to the TracVision system, decide which receiver will be the primary receiver. The primary receiver controls satellite selection.

NOTE: The secondary receiver will be able to select channels carried on the satellite that is currently selected by the primary receiver.

- Connect the supplied 5-ft RF cable from the "RF1" connector on the grounding block to the "Satellite In" connector on the primary receiver (see Figure 25).
- If you are connecting two receivers, connect an RF cable from the "RF2" connector on the grounding block to the "Satellite In" connector on the secondary receiver.
- Connect the receiver(s) to the customer's television(s). Follow the instructions in the receiver's manual.

Figure 25: Wiring the Receivers to the Antenna

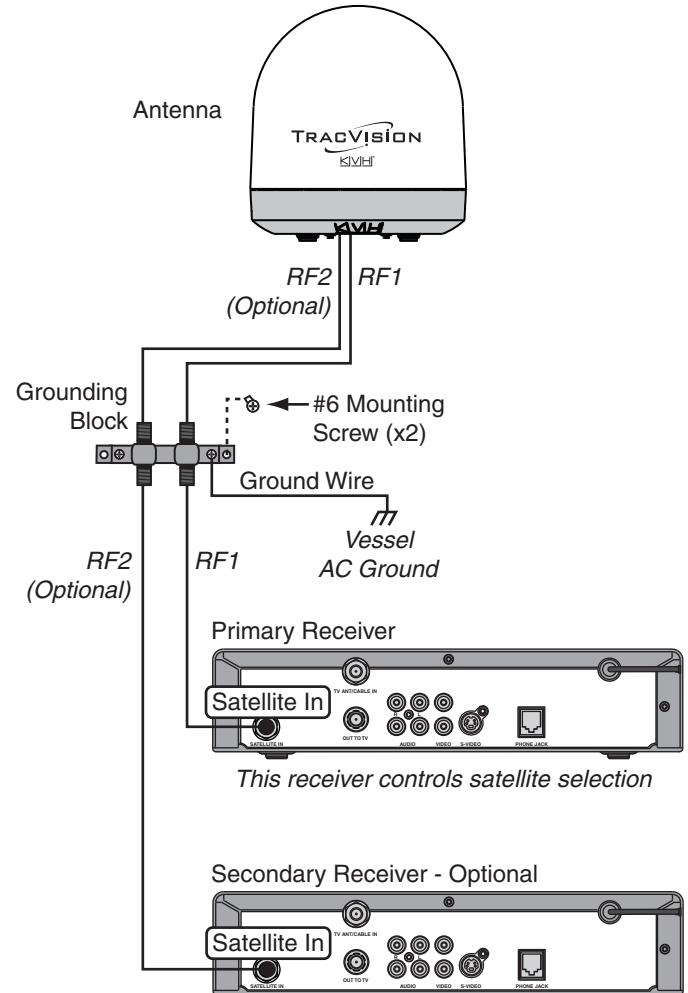

10 Wire the Receiver(s)

Linear Systems

If you are installing a **linear** system (with the exception of Sky Mexico), follow these steps to connect the customer's satellite TV receiver(s) to the TracVision system.

- a. If you are connecting two receivers to the TracVision system, decide which receiver will be the primary receiver. The primary receiver controls satellite selection.

NOTE: The secondary receiver will be able to select channels carried on the satellite that is currently selected by the primary receiver.

- b. Connect the RF1 cable from the antenna to the "Satellite In" connector on the primary receiver (see Figure 26).
- c. If you are connecting two receivers, connect the RF2 cable from the antenna to the "Satellite In" connector on the secondary receiver.

IMPORTANT!

Be sure all receivers are grounded. If the receiver has a 2-prong power plug, run a ground wire from the receiver's chassis to a suitable ground point. If a potential exists between AC and DC grounds, connect the wire to the antenna's DC return instead.

- d. Connect the receiver(s) to the customer's television(s). Follow the instructions in the receiver's manual.

Figure 26: Wiring the Receivers to the Antenna

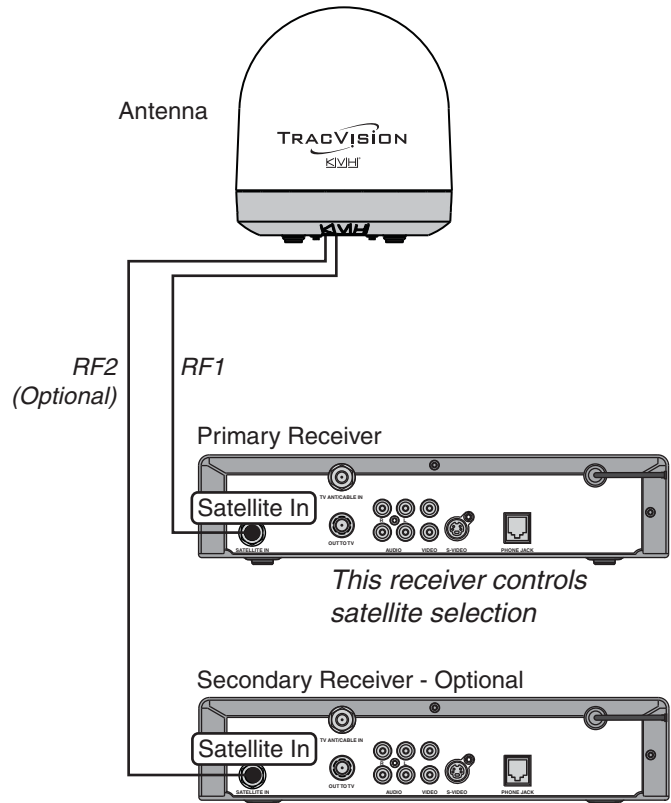

11 Wire the ADCU

Follow these steps to connect the antenna data and GyroTrac sensor cables to the ADCU.

NOTE: System wiring diagrams are provided in Appendix H on page 46.

- First dress the antenna data and power cables from the antenna. Strip back the insulation of each wire approximately 1/4" (6 mm) and gently twist each wire to ensure a good electrical connection.
- Find the five terminal strip connectors in the kitpack. You will connect wires to these plastic connectors first. Later, you will plug them into the rear panel of the ADCU.
- Connect the data cable from the antenna to the **red** and **yellow** ADCU terminal strip connectors, as shown in Figure 27. Be sure to snip and insulate any unused wires from the cable, including the drain wire (shield).

IMPORTANT!

The diagrams refer to wires by **body color/stripe color**. For example, "Blue/White" means the blue wire with white stripe.

- Connect the sensor cable to the GyroTrac sensor. Hand-tighten until the cable locks in place. Route the other end of the cable to the ADCU.
- Connect the sensor cable to the **blue** ADCU terminal strip connector, as shown in Figure 28.
- (Optional) If you wish to connect the vessel's GPS to the TracVision system, connect the GPS to the **blue** ADCU terminal strip connector, as shown in Figure 28. A GPS input will speed up satellite acquisition.

NOTE: For details on connecting other onboard equipment, such as an autopilot, plotter, radar, or remote display, see Appendix D on page 35.

Figure 27: Wiring the Antenna to the ADCU

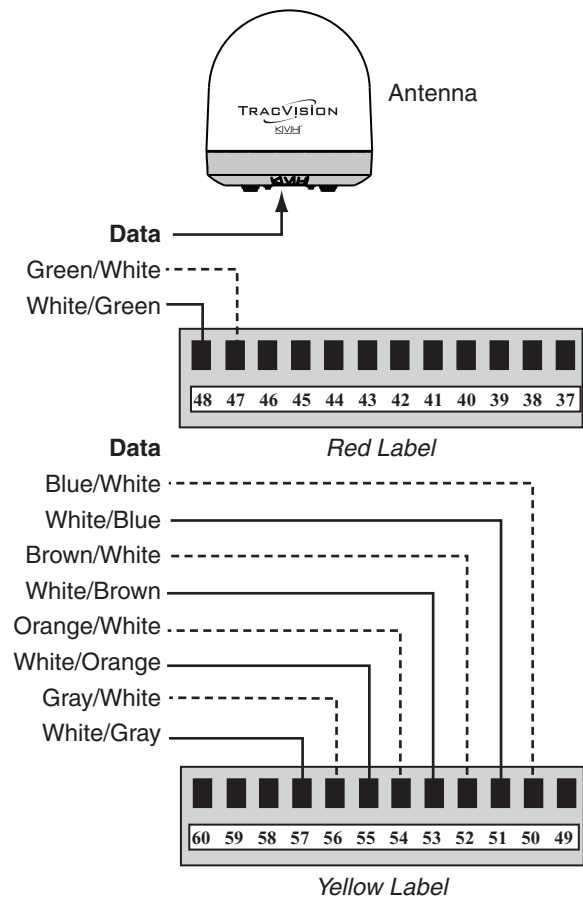
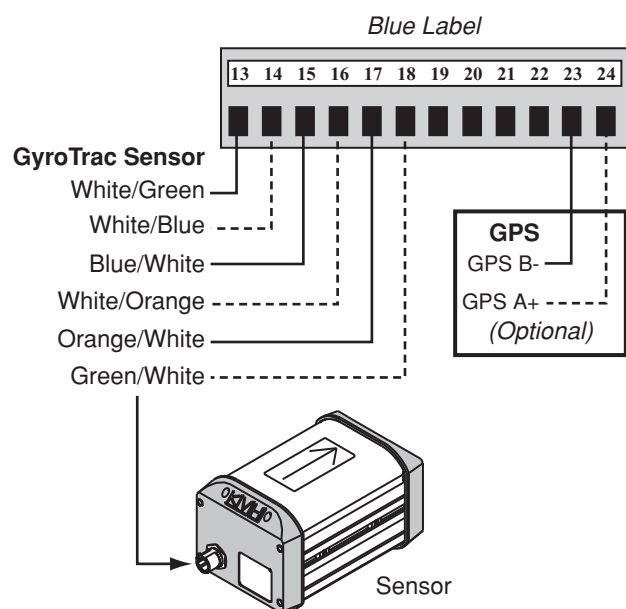

Figure 28: Wiring the Sensor and GPS to the ADCU



12 Connect Power

Follow these steps to connect power to the antenna and ADCU.

- a. Before you begin, disconnect vessel power.

CAUTION

For your own safety, disconnect vessel power and make sure the circuit is dead before you connect any power wires.

- b. Connect the power cable from the antenna to 12 VDC (4 amps continuous) vessel power via a dedicated 10-amp circuit breaker (see Figure 29).

IMPORTANT!

Power supplied to the antenna must not fall below 12 VDC or exceed 16 VDC.

- c. Connect an additional power cable from 12 VDC vessel power to the power (+) and ground (-) terminals on the **green** ADCU terminal strip connector, as shown in Figure 30 (for cable specifications, see Figure 2 on page 3).
- d. Plug all of the terminal strip connectors into the rear panel of the ADCU. Be sure to plug them into their correct positions, as shown in Figure 31.
- e. Using the supplied tie-wraps, strain-relieve all wires at the ADCU. If a ferrite is installed on the cable, position the ferrite as close as possible to the terminal strip connections and strain-relieve the wires next to the ferrite (see Figure 32). Also be sure to allow just enough slack in the cables for easy serviceability.

IMPORTANT!

Double-check all of your wiring before continuing. If wiring is incomplete or incorrect, electronics may become damaged when you apply power.

Figure 29: Wiring Vessel Power to the Antenna

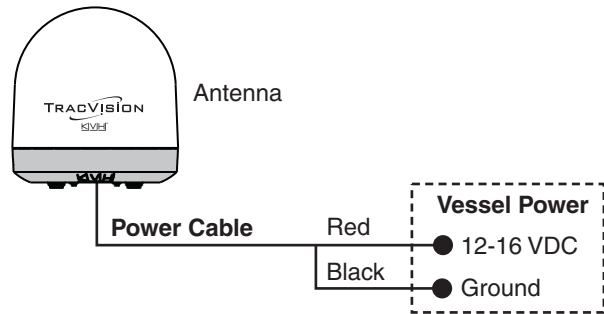

Figure 30: Wiring Vessel Power to the ADCU

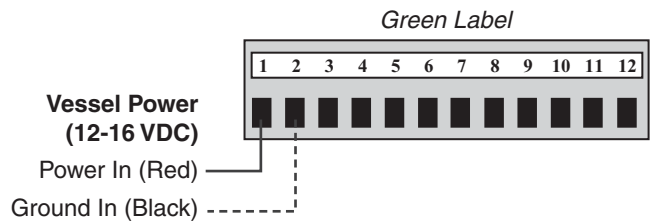

Figure 31: Plugging In the ADCU Terminal Strip Connectors

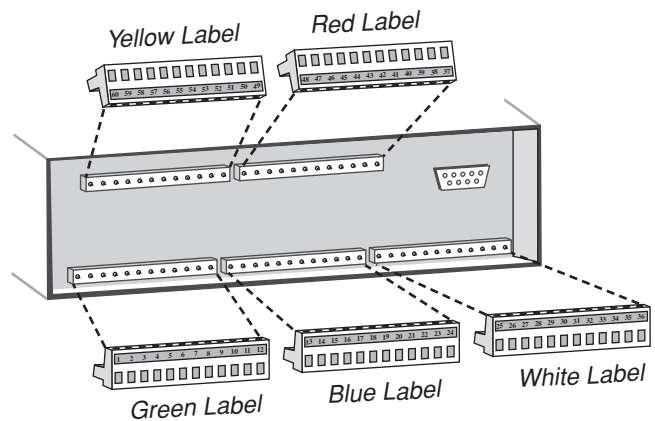
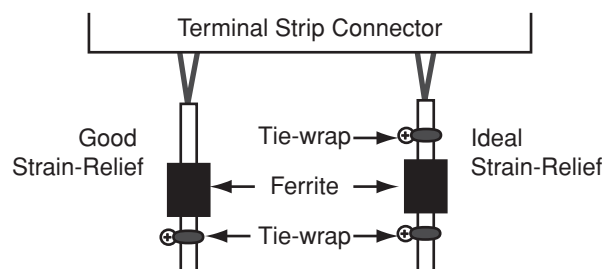

Figure 32: Effective Strain-Relief of ADCU Wires



13 Mount the ADCU

In Step 4, you identified a suitable ADCU mounting location. Now follow these steps to mount the ADCU using one of the following options:

Option 1 - Velcro mount to a horizontal surface

Option 2 - Flush mount to a vertical surface

Option 1 - Velcro Mount

- Clean and dry the bottom of the ADCU and the mounting surface (use a mild detergent).
- Peel the backing from the four supplied Velcro fabric squares and stick them to the bottom corners of the ADCU (see Figure 33).
- Position the four Velcro hook disks onto the mounting surface. Drill screw holes for the disks and secure in place with #4-24 screws.
- Press the ADCU firmly into place so the fabric's loop material engages the hook disks.

Option 2- Flush Mount

- At the bottom of the ADCU, loosen the two #6-32 screws (see Figure 34).
- Slide the flush mount bracket backward onto the ADCU until the two notches in the bracket engage the screws at the bottom of the ADCU.
- Tighten the screws to secure the bracket to the ADCU.
- In Step 4 on page 6, you cut out the mounting hole in the mounting surface. Insert the ADCU and bracket assembly into this mounting hole and secure in place with four #8 screws and washers (see Figure 35).

Figure 33: Velcro Mounting

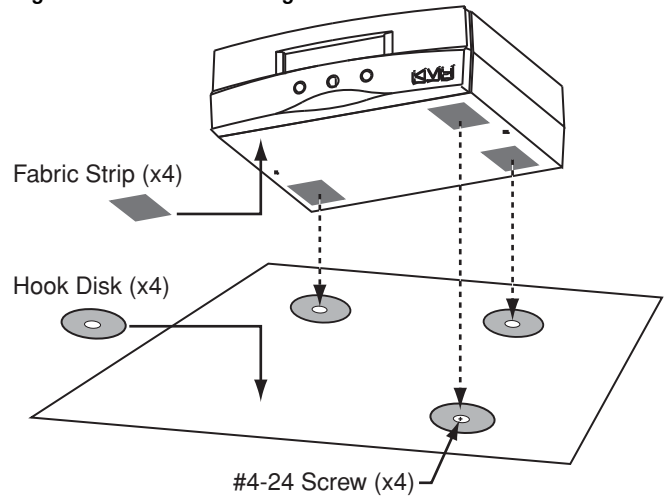

Figure 34: Flush Mount Bracket

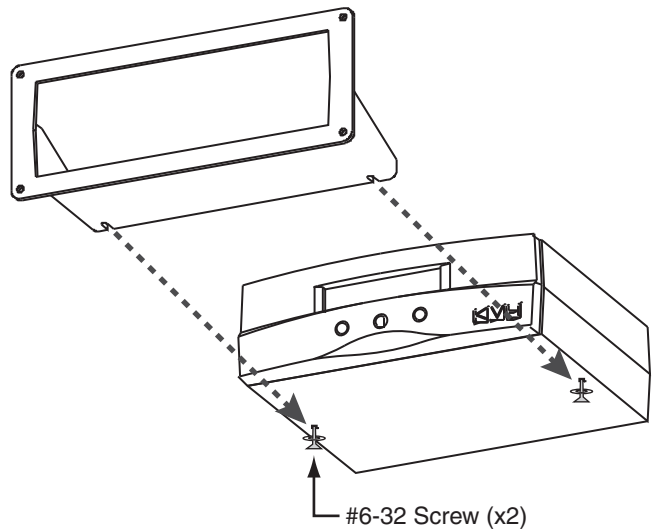
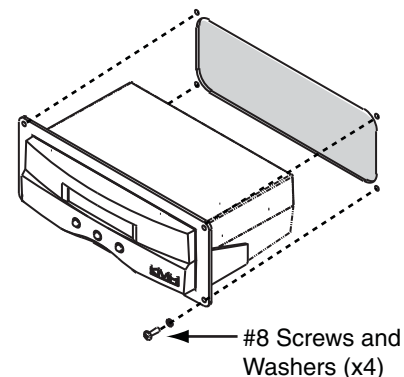

Figure 35: Flush Mounting the ADCU to a Vertical Surface



14 Select Satellites

Tri-Sat Mode - Circular Systems

Follow these steps to set up a **circular** system for one of the three available Tri-Sat modes (see Figure 36). If you wish to set up the system for one or two satellites instead, skip this step and proceed to page 20.

IMPORTANT! **(DISH Network only)** If you wish to receive DISH Network's three-satellite service, be sure to install the appropriate DISH 1000 satellites for your geographic area, as shown in Figure 37. If you wish to install DISH 1000/61 service, you can skip this step and proceed to page 21. If you wish to install DISH 1000/129 service, follow the procedure below.

- a. Connect a laptop PC to the Maintenance port on the back of the ADCU. See Appendix B on page 33 for connection details.
- b. Ensure the antenna has a clear, unobstructed view of the sky.
- c. Apply power to the receiver(s), TV(s), ADCU, and antenna. Wait one minute for system startup.
- d. Using Windows HyperTerminal (or equivalent) or KVH Flash Update Wizard, type **HALT** then press Enter.
- e. Type **DEBUGON** then press Enter.
- f. Type the appropriate command in Figure 36 for the desired Tri-Sat mode.
- g. Type **ZAP** then press Enter. The antenna restarts. Wait one minute for system startup.

Figure 36: Satellite Install Commands for Circular Tri-Sat Modes

Tri-Sat Mode (Satellites)	Command
DIRECTV Tri-Sat* (101, 110, 119)	SATINSTALL,TRISAT, DSS
DISH 1000/129 (119, 110, 129)	SATINSTALL,TRISAT, DISH
DISH 1000/61 (119, 110, 61)	SATINSTALL,TRISAT, DISH61

* Reception of satellite 110 requires Tri-Sat AutoSwitch Kit (KVH part #72-0301-07)

Figure 37: Recommended Areas for DISH 1000 Satellites

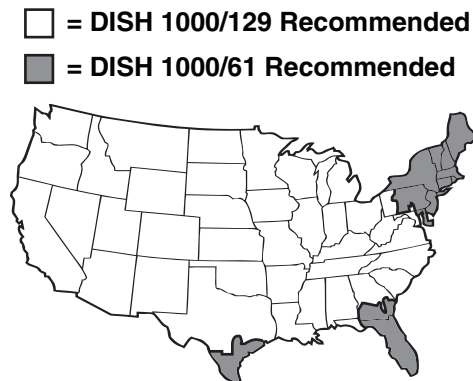

EXAMPLE

Programming DISH Network's 119, 110, and 129 satellites:

```

HALT
DEBUGON
SATINSTALL,TRISAT,DISH
ZAP
  
```

14 Select Satellites

Tri-Sat Mode - Linear Systems

Follow these steps to set up a **linear** system for one of the three available Tri-Sat modes (see Figure 38). If you wish to set up the system for one or two satellites instead, skip this step and proceed to page 20.

- a. Connect a laptop PC to the Maintenance port on the back of the ADCU. See Appendix B on page 33 for connection details.
- b. Ensure the antenna has a clear, unobstructed view of the sky.
- c. Apply power to the receiver(s), TV(s), ADCU, and antenna. Wait one minute for system startup.
- d. Using Windows HyperTerminal (or equivalent) or KVH Flash Update Wizard, type **HALT** then press Enter.
- e. Type **DEBUGON** then press Enter.
- f. Type the appropriate command in Figure 38 for the desired Tri-Sat mode.
- g. Type **ZAP** then press Enter. The antenna restarts. Wait one minute for system startup.
- h. Set up the receiver(s) for the same satellites, and in the same order, that you set them up in the antenna:

Antenna	Receiver	DiSEqC
Sat. A	Alternative 1 or A	DiSEqC 1
Sat. B	Alternative 2 or B	DiSEqC 2
Sat. C	Alternative 3 or C	DiSEqC 3

Figure 38: Satellite Install Commands for Linear Tri-Sat Modes

Satellites	Command
A = Hotbird B = Astra 1 C = Astra 2S	SATINSTALL,TRISAT, EUR
A = Hotbird WB B = Astra 1 C = Astra 2S	SATINSTALL,TRISAT, EWB
A = Hotbird WB B = Sirius C = Thor	SATINSTALL,TRISAT, SCN

EXAMPLE

Programming the Hotbird WB, Astra 1, and Astra 2S satellites:

```

HALT
DEBUGON
SATINSTALL,TRISAT,EWB
ZAP
    
```

14 Select Satellites

Dual-Sat or Single-Sat Mode

Follow these steps to set up the system for one or two satellites.

- Ensure the antenna has a clear, unobstructed view of the sky. Then apply power to the receiver(s), TV(s), ADCU, and antenna. Wait one minute for system startup.
- Press the center **MENU** button on the ADCU to access the onscreen menu (see Figure 39).
- At "Setup display type?", press **NEXT** until the display shows "Control antenna?" Then press **ENTER** and press **YES** to confirm.
- At "Man control antenna?", press **NEXT** until the display shows "Install satellite?" Then press **YES**.
- At "Install A <SAT NAME>", press **NEXT** until the display shows the first (primary) satellite you want to select. Then press **YES**. (See Appendix C on page 34 for a list of available satellites.)

NOTE: If you don't find the satellite you want, you can set up user-defined satellites. Refer to the associated Application Note on the KVH Partner Portal (KVH-authorized technicians only).

- Repeat Step e to select the second satellite. If you want to set up the antenna to track just one satellite, select "None" instead.
- (If necessary)** At "Latitude", use the - and + buttons to set each digit of the vessel's latitude. Press **ENTER** to accept each digit. (See Appendix G on page 45 for approximate positions in Europe or North America.)
- At "Longitude", set the vessel's longitude.
- At "Restart antenna?", press **YES**. Wait one minute while the antenna restarts.
- (Linear systems only)** Set up the receiver(s) for the same satellites, and in the same order, that you set them up in the antenna:

Antenna	Receiver	DiSEqC
Sat. A	Alternative 1 or A	DiSEqC 1
Sat. B	Alternative 2 or B	DiSEqC 2

Figure 39: Satellite Selection Menus on ADCU

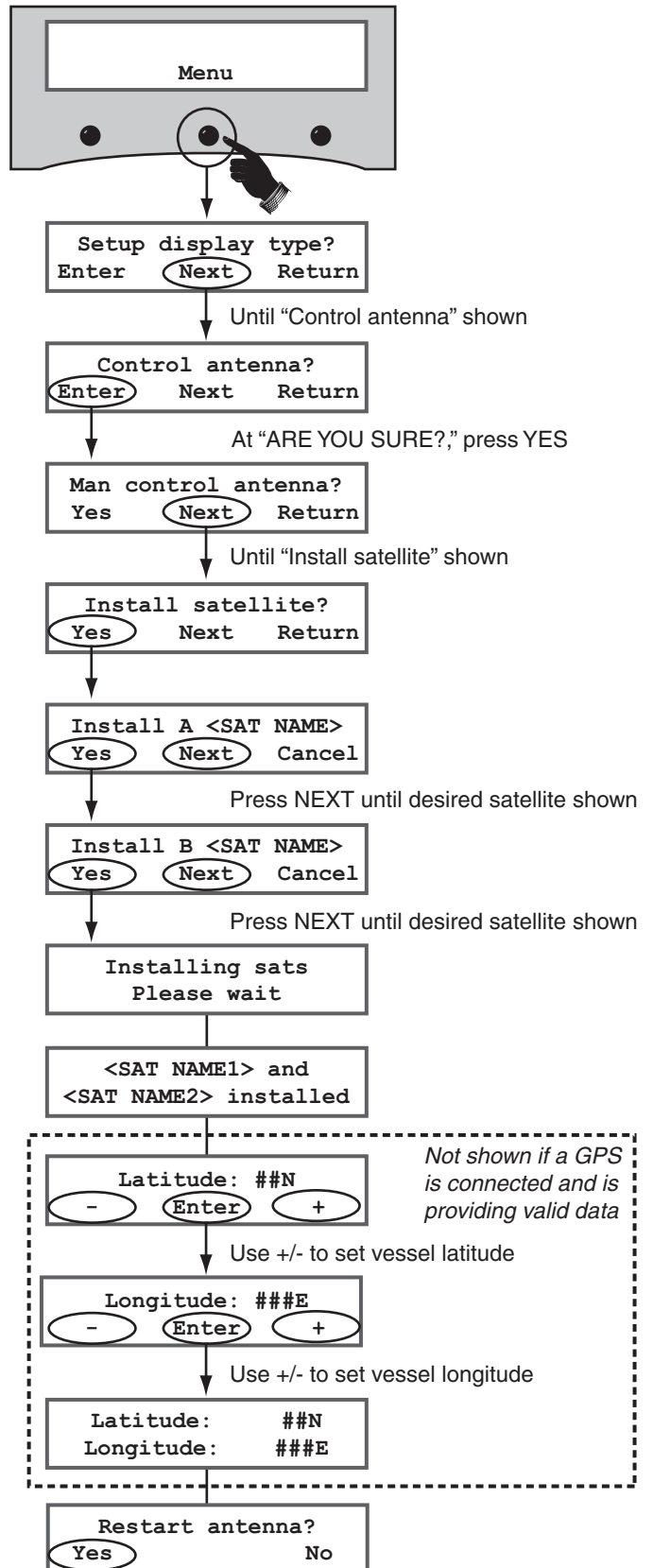

15 Enter Your Latitude & Longitude

Tri-Sat Mode Only

If you set up the system for a Tri-Sat mode, and you do not have a GPS connected to the ADCU, follow these steps to enter your vessel's latitude and longitude into the system.

IMPORTANT!

If you set up the system for one or two satellites, you may skip this step since you already entered latitude/longitude during the satellite selection process; proceed to page 22.

NOTE: The antenna will use your position information to speed up satellite acquisition. If the antenna knows where you are, it knows where it should start looking for the satellite. In addition, for a linear system, the antenna will use your position information to calculate the correct LNB skew angle.

TIP: You can determine your approximate latitude and longitude in Europe or North America from the position grids provided in Appendix G on page 45.

- Press the center **MENU** button on the ADCU to access the onscreen menu (see Figure 40).
- At "Setup display type?", press **NEXT** until the display shows "Control antenna?" Then press **ENTER** and press **YES** to confirm.
- At "Man control antenna?", press **NEXT** until the display shows "Set Lat/Long?" Then press **YES**.
- At "Latitude", use the - and + buttons to set each digit of the vessel's latitude. Press **ENTER** to accept each digit.
- At "Longitude", set the vessel's longitude.
- At "Set Lat/Long?," press **NEXT** until the display shows "Restart antenna?" Then press **YES**. Wait one minute while the antenna restarts.

Figure 40: Lat/Long Menus on ADCU

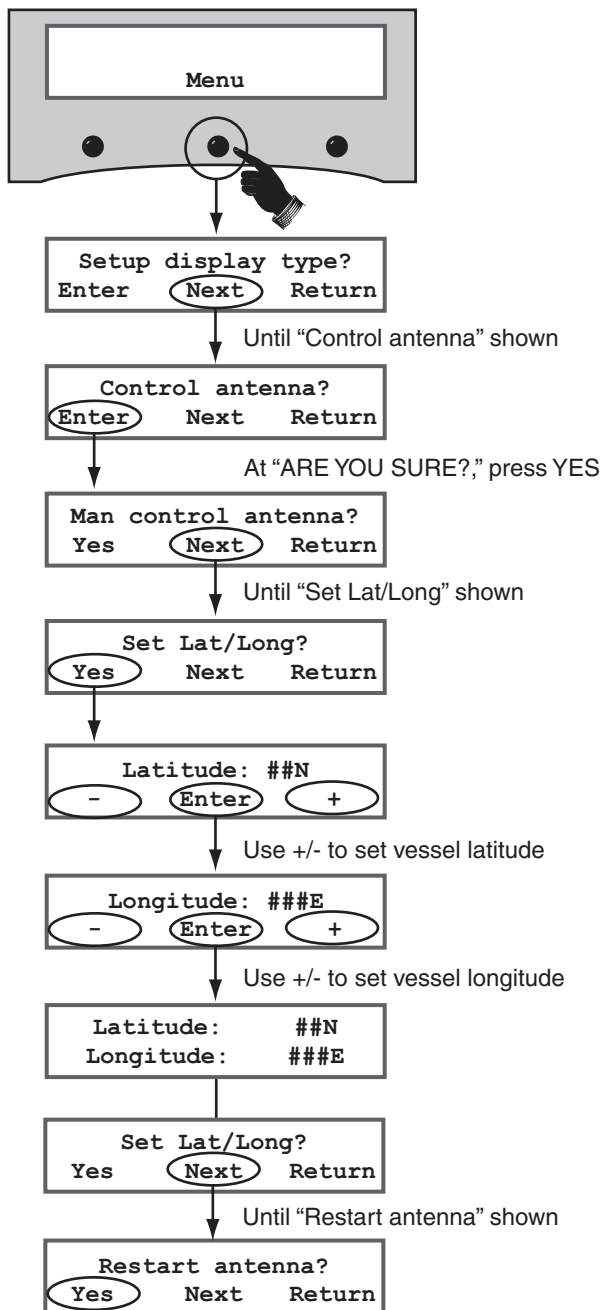

16 Get the LNB Skew Angle

Linear Systems Only

To optimize reception, the antenna's LNB must be set to the correct skew angle for the linear satellite(s) you want to track. Follow these steps to determine the correct skew angle for your currently selected satellite and vessel position.

TIP: You might also be able to get the correct skew angle from the customer's satellite service provider.

- Press the center **MENU** button on the ADCU to access the onscreen menu (see Figure 41).
- At "Setup display type?", press **NEXT** until the display shows "Get antenna status?" Then press **ENTER** and press **YES** to confirm.
- At "Get system errors?", press **NEXT** until the display shows "Get skew angle?" Then press **YES**.
- The display shows the calculated skew angle for the selected satellite and position. Note this number for future reference.

NOTE: If you did not connect a GPS to the ADCU, the antenna will use the position information you entered earlier to calculate the correct LNB skew angle.

- Press any button. The display returns to the "Get skew angle?" screen.
- Press **RETURN** until you exit the menu.

*TIP: This procedure provides the correct skew angle for the currently selected satellite only. If you selected multiple satellites in Step 14, you might wish to calculate the **average skew** instead. To find the average skew, select the second satellite (see the User's Guide for details) then repeat the procedure above to get the calculated skew angle for the second satellite (repeat for the third satellite if Tri-Sat). Add the skew angle numbers and divide by two (or three if Tri-Sat) to get the average.*

Figure 41: Skew Angle Menus on ADCU

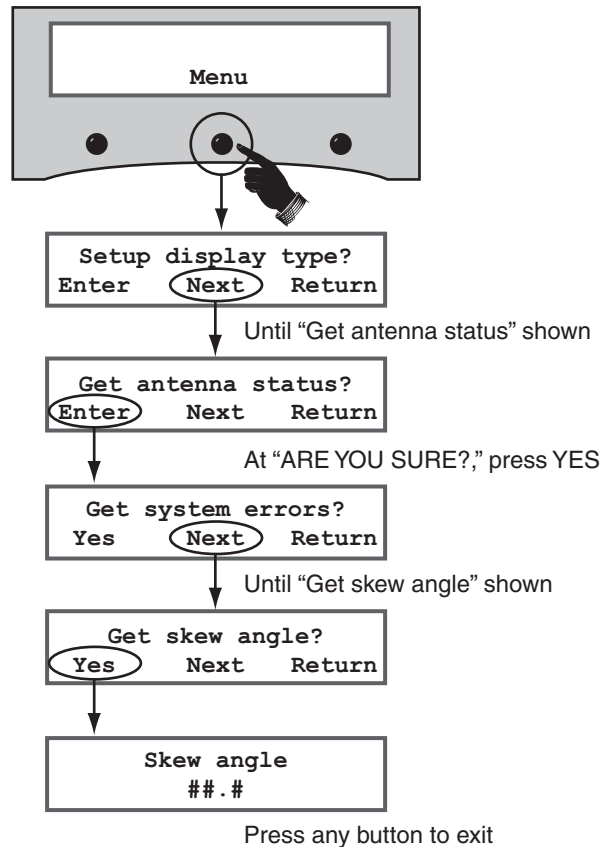

17 Set the LNB Skew Angle

Linear Systems Only

Follow these steps to set the antenna's LNB to the skew angle you noted in Step 16.

- a. Turn off and unplug the receiver(s) and disconnect antenna power.



CAUTION

Disconnect power from the antenna and the receivers before you adjust the LNB. The antenna's moving parts can cause injury.

- b. Remove the antenna's radome, if you reinstalled it earlier in Step 8.
- c. Locate the LNB on the back of the antenna's reflector (see Figure 42).
- d. Using a 2 mm allen hex key, loosen the two M4 socket set screws securing the LNB to the reflector (see Figure 43).
- e. Adjust the LNB clockwise or counter-clockwise until the skew arrow on the LNB points to the skew angle that you noted in Step 16 (see Figure 44). If the skew angle is greater than $+15^\circ$, subtract 180 to get the equivalent negative skew angle and set the LNB to that angle instead (e.g., $+35 = -145$).

IMPORTANT!

Be sure to keep the LNB fully inserted into the choke feed to ensure optimum performance.

- f. Tighten the two M4 socket set screws to secure the LNB in place. Apply 9 in-lbs (1 Nm) of torque, if possible.
- g. Reinstall the radome (as explained in Steps 8e-f on page 10).

Figure 42: LNB Location on Back of Antenna's Reflector

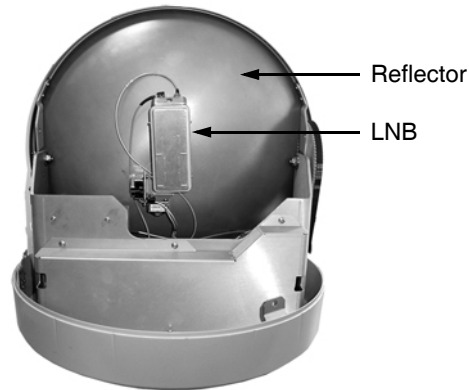

Figure 43: Set Screws Securing the LNB to the Reflector

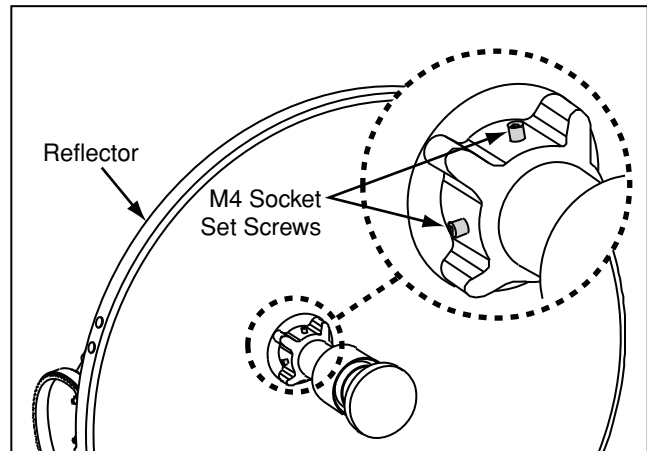
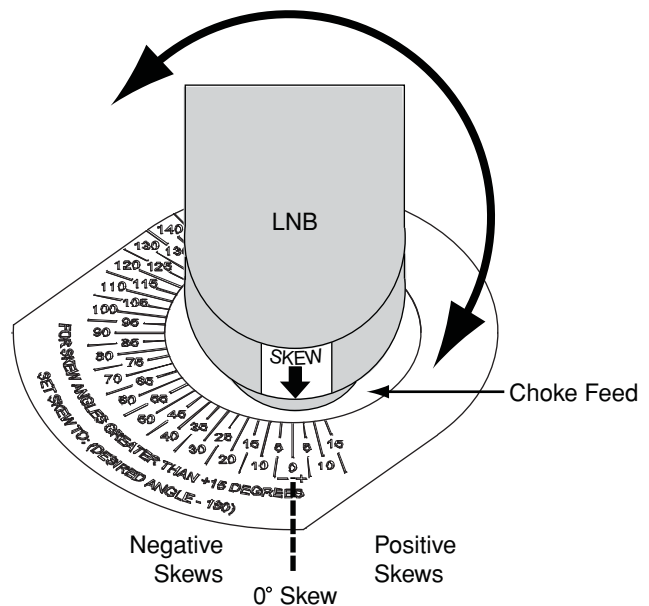

Figure 44: LNB Skew Angle Adjustment



18 Run Two Check Switch Tests

DISH Network or ExpressVu Only

If you set up the system for **DISH Network** or **ExpressVu**, follow these steps to run the receiver's Check Switch test twice. The first Check Switch test finds the satellites; the second test configures the receiver for those satellites.

IMPORTANT!

This procedure must be performed while the vessel is docked in **calm** water.

NOTE: If you are connecting multiple receivers, repeat this process for each additional receiver. You will need to connect each receiver, one at a time, to the "RF1" cable and perform the steps below. Then, once you have completed this process for each receiver, you can reconnect them as desired.

- a. Dock the vessel and ensure the antenna has an unobstructed view of the sky.
- b. Ensure the receiver is connected to the "RF1" cable (see Figure 25 on page 13 (circular/Sky Mexico) or Figure 26 on page 14 (linear)).
- c. Apply power to the TV and receiver. (If the antenna is turned off, turn it back on and wait until the ADCU indicates "Tracking.")
- d. Using the receiver remote, go to the "Point Dish/Signal Strength" screen (press MENU, 6, 1, 1 on most models).
- e. Choose **Check Switch**, then press SELECT.
- f. Choose **Test**, then press SELECT.
- g. Wait at least 15 minutes before proceeding to allow the antenna to find all of the satellites. Disregard any messages on the TV; they do not correctly indicate when the antenna is ready for the next Check Switch test.
- h. After waiting 15 minutes, repeat Steps d-f to run a second Check Switch test.
- i. Refer to the tables in Figure 45 to verify the values displayed on your TV match those required for your selected service. If your values do not match, turn off the antenna, then turn it back on and repeat Steps d-h.
- j. Exit the menu and allow the receiver to download the program guide.

Figure 45: Expected Check Switch Results Displayed on TV

DISH 1000/129 Results

Port	1	2	3
Satellite	119	110	129
Trans	OK	OK	OK
Status	Reception Verified		
Switch	SW64		

DISH 1000/61 Results

Port	1	2	3
Satellite	119	110	61
Trans	OK	OK	OK
Status	Reception Verified		
Switch	SW64		

DISH 500 Results

Input	1	1	2	2
Satellite	119	119	110	110
Polarity	Odd	Even	Odd	Even
Status	Reception Verified			
Switch	SW42			

ExpressVu Results*

Input	1	1	2	2
Satellite	91	91	82	82
Polarity	Odd	Even	Odd	Even
Status	Reception Verified			
Switch	SW21			

* If you installed just one ExpressVu satellite, the TV will show an error message instead. This is normal.

19 Calibrate the Sensor

Every GyroTrac sensor is calibrated at the factory for a perfect-world environment. However, hard and soft iron effects on your vessel can distort the magnetic field around the sensor, causing errors in its reported heading. To compensate for these magnetic distortions, follow these steps to calibrate the sensor.

NOTE: If you are not installing the GyroTrac sensor for the first time, you will need to clear the calibration score first (see Appendix F on page 44).

Run the Autocalibration Function

The system's Autocalibration function is set to "On" at the factory. This function allows the sensor to calibrate itself automatically when you steer the vessel through two circles.

- Select a calm day and navigate the vessel to a clear area. Excessive pitching and rolling can distort calibration data.
- Apply power to the TracVision system.
- Just before you begin, note the vessel's heading.
- Steer the vessel at a slow, steady speed through two full circles that take at least two minutes each to complete (see Figure 46). Use the heading you noted in Step c to confirm when you have completed each full circle.

TIP: Try to time your turns so that it takes approximately 30 seconds to turn 90°. Each circle does not have to be completely round, but make sure you turn a full 360° for each.

Check the Calibration Score

Once you have completed the two circles, follow these steps to check the calibration "score."

- Press the center **MENU** button on the ADCU to access the onscreen menu (see Figure 47).
- At "Setup display type?", press **NEXT** until the display shows "Control compass?" Then press **ENTER** and press **YES** to confirm.
- At "Set AutoCal On/Off?", press **NEXT** until the display shows "Read Cal score?" Then press **YES**.

Figure 46: Running Autocalibration

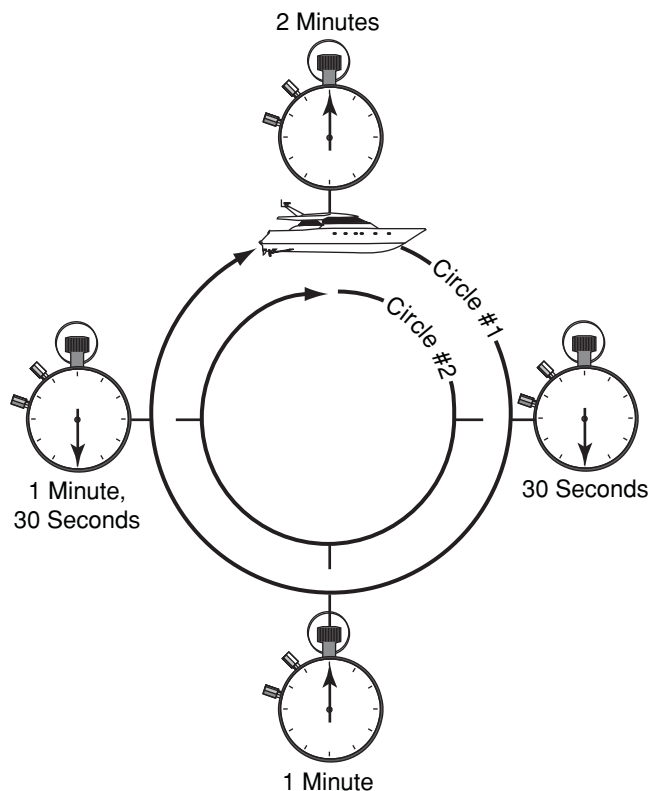
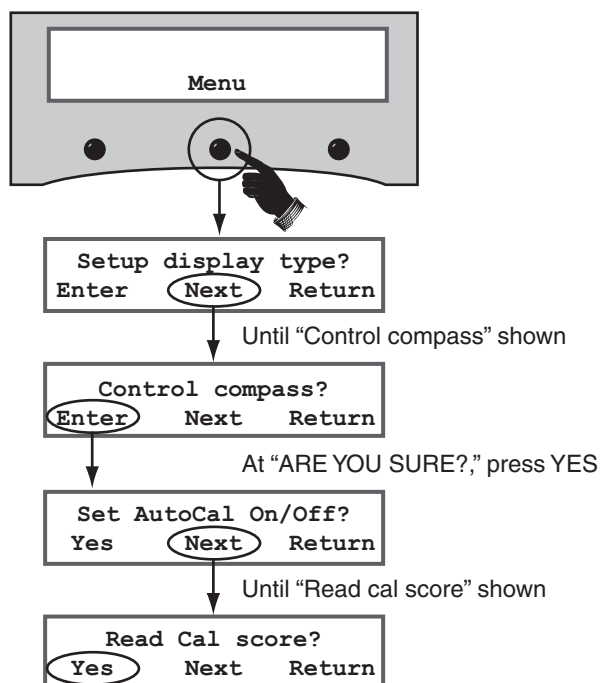

Figure 47: Viewing the Calibration Score on the ADCU



19 Continued Calibrate the Sensor

- d. The display shows the calibration score for the calibration you just performed with the Autocalibration function (see Figure 48).
- e. **If Accuracy = "BAD CAL":**
Recalibrate the sensor by navigating through two additional circles. Repeat until you achieve a suitable accuracy rating.
- f. **If Mag. Environment = "POOR" or "BAD":**
Relocate the sensor to a more favorable magnetic environment (see Step 3 on page 5 for guidelines). Then clear the calibration score (see Appendix F on page 44) and recalibrate the sensor.
- g. Press the center button. The display returns to the "Read Cal score?" screen.
- h. Press **RETURN** until you exit the menu.

Figure 48: Calibration Score Example

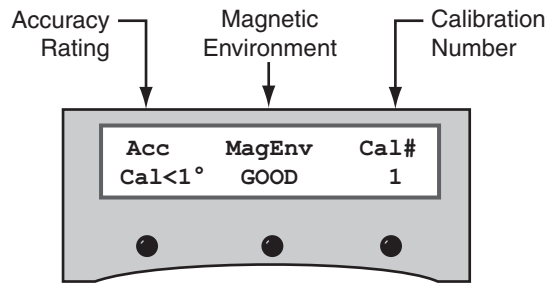

Data Field	Description
Accuracy Rating	Degree of accuracy the sensor will provide (Cal < 1° = within 1°)
Magnetic Environment	Quality of the sensor's installation site
Calibration Number	Number of times the sensor was calibrated

Turn Off Autocalibration

Once you have achieved a good calibration score, follow these steps to turn off the Autocalibration function.

- a. Press the center **MENU** button on the ADCU to access the onscreen menu (see Figure 49).
- b. At "Setup display type?", press **NEXT** until the display shows "Control compass?". Then press **ENTER** and press **YES** to confirm.
- c. At "Set AutoCal On/Off?", press **YES**.
- d. At "AutoCal is: ON", press **OFF**.
- e. At "AutoCal is: OFF", press **ENTER**. The display returns to the "Set AutoCal On/Off?" screen.
- f. Press **RETURN** until you exit the menu.

Figure 49: Turning Off Autocalibration at the ADCU

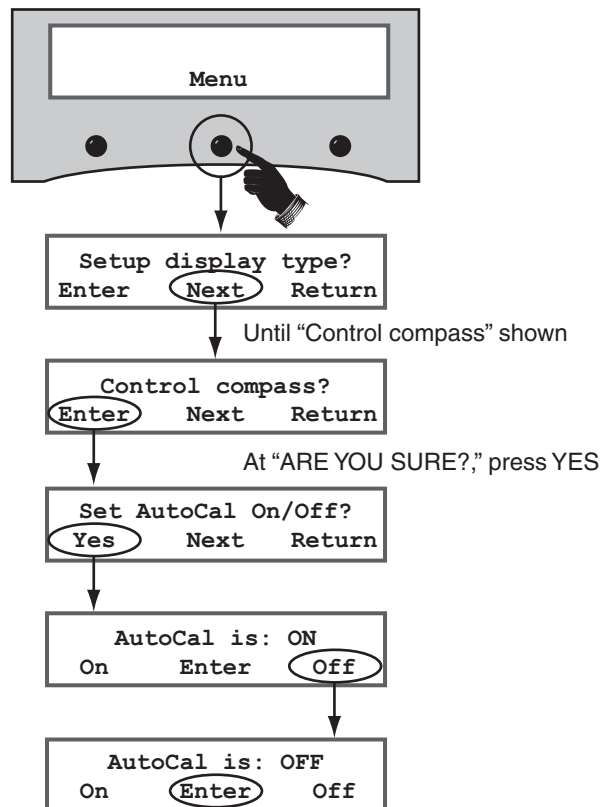

20 Educate the Customer

The installation process is complete! Before you leave the vessel, test the system to verify the antenna works properly. Then give the Customer Welcome Kit to the customer and explain how to use the system. Also be sure the customer understands the following:

- Keep the radome installed on the antenna at all times. The radome protects the antenna's moving parts from wind, rain, and debris.



WARNING

It is dangerous to watch TV while piloting a vessel. When under way, the system is intended for passenger entertainment only.

- The antenna must have a clear view of the sky to receive satellite TV. Common causes of blockage include trees, buildings, bridges, and onboard equipment (see Figure 50).
- Heavy rain or snow may temporarily interrupt reception.
- Clean the antenna regularly. Dirt buildup on the radome can affect reception.
- The vessel must be located within the selected satellite's coverage area to receive its satellite TV signals. To view satellite coverage maps, visit www.kvh.com/footprint.
- **(DISH 1000 only)** You may need to change the operating mode when traveling between regions. Refer to the *User's Guide* for details.
- Please register the system with KVH. The registration process is quick, easy, online, and ensures the best possible service from KVH. Visit www.kvh.com/register or refer to the Product Registration Form for details.
- You need to activate the receiver for the desired satellite TV service before the receiver can decode satellite signals. KVH can help activate a DIRECTV or DISH receiver; just call KVH's Activation Department at **1-866-551-8004** for DIRECTV or **1-866-399-8509** for DISH.
- Refer to the *User's Guide* for complete operation and troubleshooting information.

Figure 50: Example of Satellite Blockage

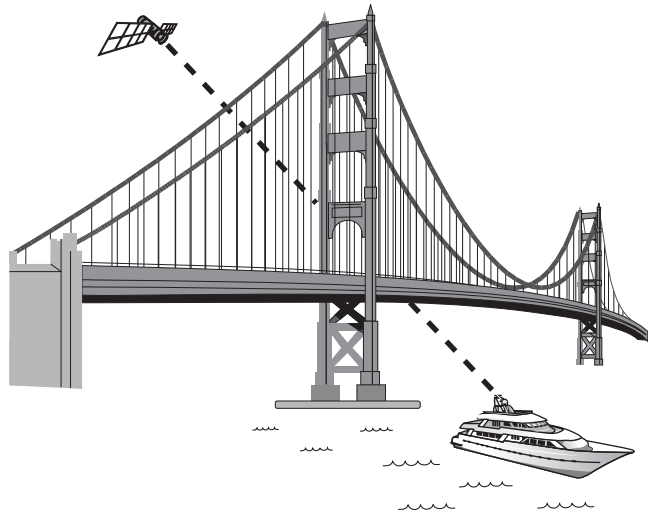

Appendices

This section provides supplemental instructions for wiring multiple receivers. It also provides a list of available satellites, system wiring diagrams, and a mounting template for the belowdecks equipment.

Contents

- A. Wiring 3+ Receivers, 31
- B. Connecting a PC to the ADCU, 33
- C. Satellite Library, 34
- D. Connecting External Equipment, 35
- E. Entering Sensor Offset Values, 42
- F. Clearing the Calibration Score, 44
- G. Position Grids, 45
- H. Wiring Diagrams, 46
- ADCU Flush Mounting Template, 49

A Wiring 3+ Receivers

Circular Systems

IMPORTANT!

Only circular and Sky Mexico systems can support more than two receivers.

To connect three or more receivers to a **circular** system, follow these steps to install an Eagle Aspen multiswitch (KVH part #72-0310) between the grounding block and the receivers, as shown in Figure 51.

1. Connect an RF cable from the “RF1” connector on the grounding block to the “13V” connector on the multiswitch.
2. Connect an RF cable from the “RF2” connector on the grounding block to the “18V” connector on the multiswitch.
3. Connect the receivers to the individual outputs of the multiswitch.
4. Connect the receivers to the customer’s TVs.

The use of a multiswitch interrupts satellite switching communications between the receiver and antenna. As a result, you will need to use one of the following methods for satellite switching:

Automatic Switching for DIRECTV Ku-band Tri-Sat:

To switch automatically between three satellites using a DIRECTV H21-200 or H20-600 receiver, you will need to install the KVH Tri-Sat AutoSwitch Kit (KVH part #72-0301-07).



Manual Switching (Tri-Sat or Dual-Sat):

To manually switch between two or three selected satellites, use the buttons on the ADCU’s front panel (see the *User’s Guide* for details).

Figure 51: Multiswitch Wiring - Antenna with Circular Dual LNB

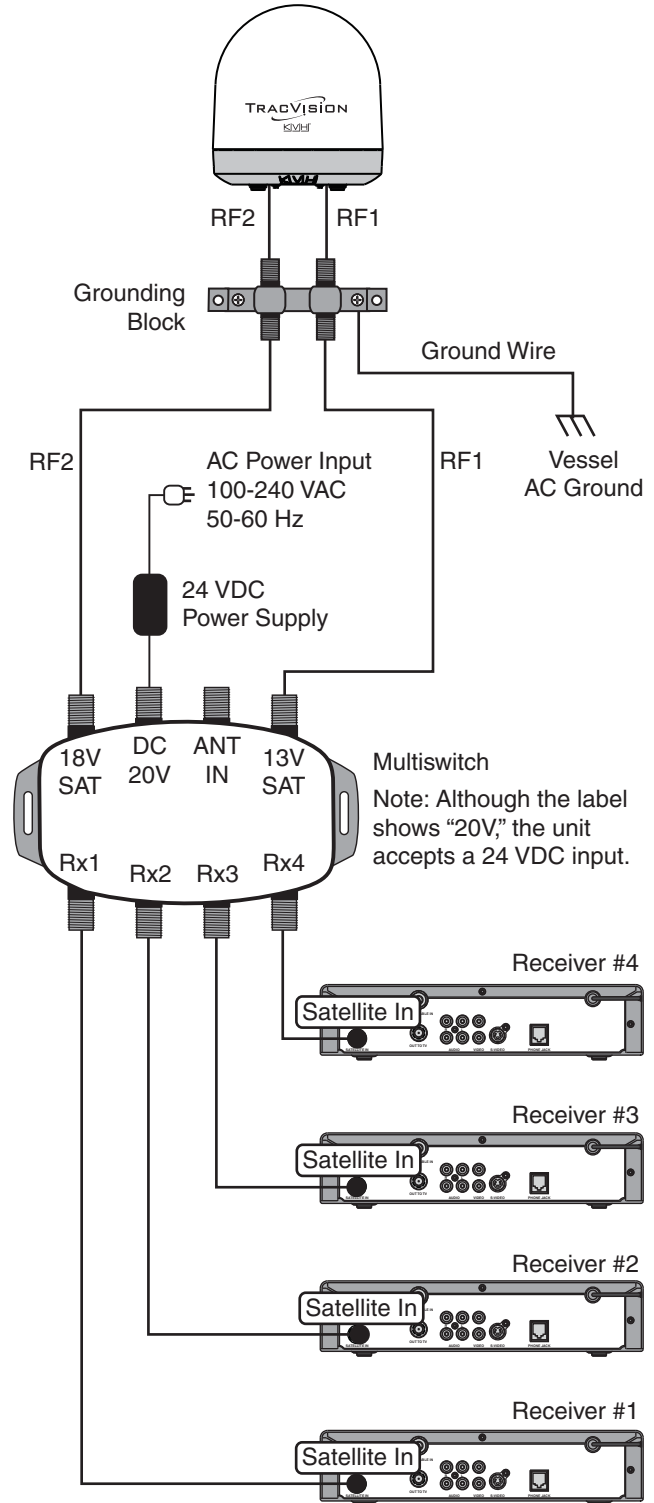

A Wiring 3+ Receivers

Sky Mexico Systems

IMPORTANT!

Only circular and Sky Mexico systems can support more than two receivers.

To connect three or more receivers to a system configured for **Sky Mexico**, follow these steps to install a Spaun model SMS 5602 NF multiswitch (KVH part #19-0413) between the grounding block and the receivers, as shown in Figure 52.

1. Connect an RF cable from the "RF1" connector on the grounding block to the "H/High" (Horizontal High) connector on the multiswitch.
2. Connect an RF cable from the "RF2" connector on the grounding block to the "V/High" (Vertical High) connector on the multiswitch.
3. Set the multiswitch's LNB knob to "22 KHz." *At this setting, the multiswitch will provide a constant 22 KHz tone to the antenna's LNB.*
4. Connect the receivers to the individual outputs of the multiswitch.
5. Connect the receivers to the customer's TVs.

Figure 52: Multiswitch Wiring - Sky Mexico

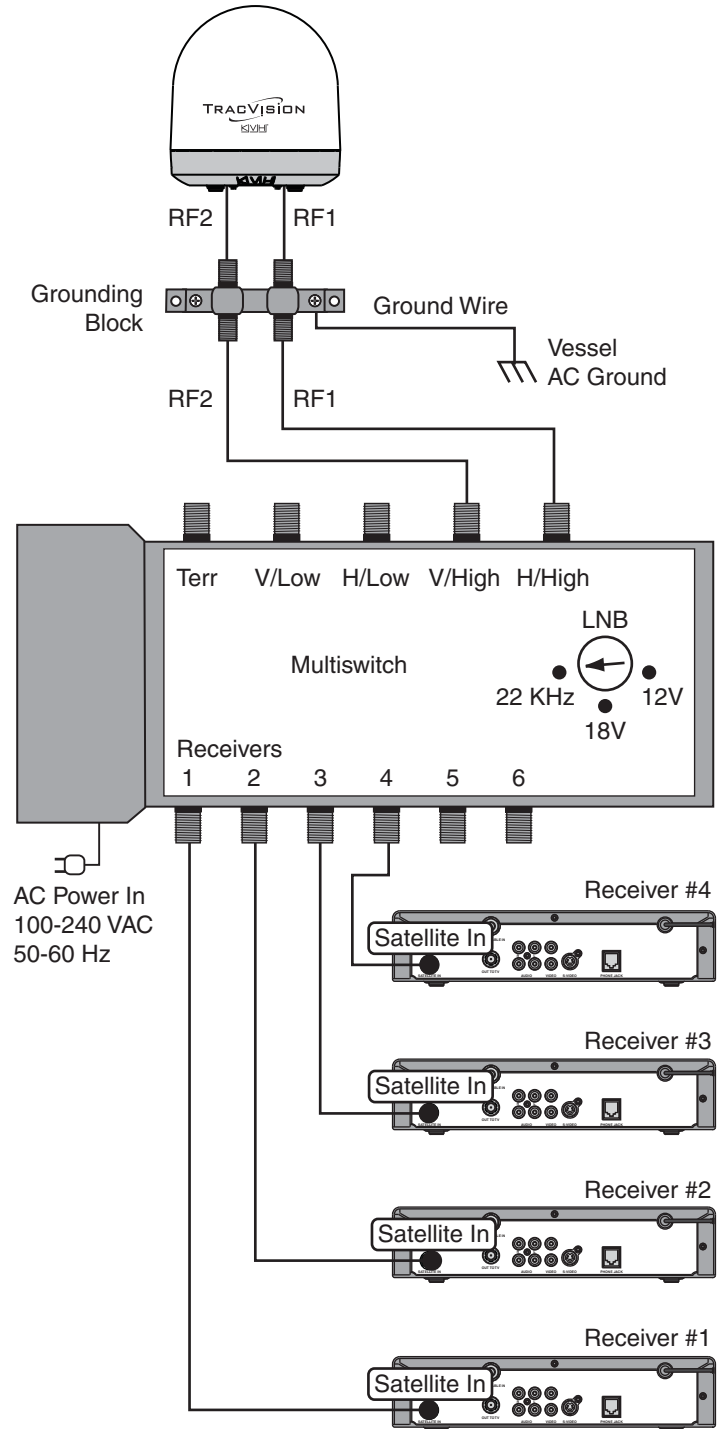

B Connecting a PC to the ADCU

If you need to manually enter commands into the antenna (for example, to set up the system for a Tri-Sat mode), follow these steps to connect your laptop PC to the ADCU.

TIP: If you are a KVH-authorized technician, you can use the KVH Flash Update Wizard instead of HyperTerminal. Enter commands in the wizard's "TracVision Antenna Comms" window.

1. Using a PC serial data cable, connect your laptop to the DB9 Maintenance port on the back of the ADCU (see Figure 54).

NOTE: If your computer does not have a DB9 serial COM port, you can use the USB-to-RS232 adapter manufactured by IOGear (IOGear part number GUC232A) or Belkin (Belkin part number F5U109 or F5U409).

2. Open Windows HyperTerminal (or equivalent) and establish the following settings for your COM port (see Figure 55):
 - Bits per second: 9600
 - Data bits: 8
 - Parity: None
 - Stop bits: 1
 - Flow control: None

TIP: To view characters on the screen as you type, set up HyperTerminal to echo typed characters. Select "Properties" from the File menu; select "ASCII Setup" at the Settings tab; then select "Echo typed characters locally" at the ASCII Setup window.

Figure 53: Technician Programming the Antenna



Figure 54: Maintenance Port on ADCU

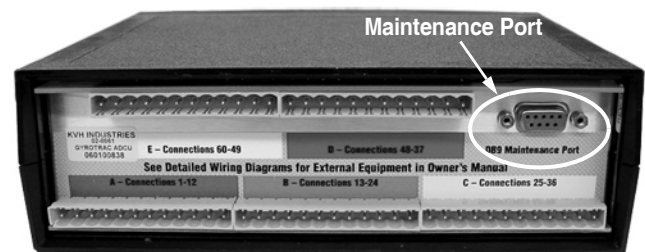
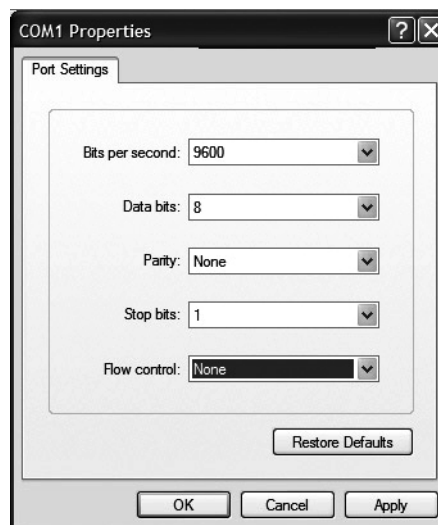

Figure 55: HyperTerminal Settings



Satellite Library

The TracVision antenna can track a variety of DVB-compatible and DSS (DIRECTV) satellites. Most popular satellites are programmed in the antenna's library (see the tables below).

North America

Circular LNB Required

DIRECTV Dual-Sat: DSS_101, DSS_119

DISH 500: ECHO_119, ECHO_110

ExpressVu: EXPRESSTV, EXPRESSVU

Satellite, Longitude	Name in Library
DIRECTV, 72°W	DSS_72
DIRECTV, 101°W	DSS_101
DIRECTV, 110°W	DSS_110
DIRECTV, 119°W	DSS_119
EchoStar, 61°W	ECHO_61
EchoStar, 110°W	ECHO_110
EchoStar, 119°W	ECHO_119
EchoStar, 129°W	ECHO_129
ExpressVu, 82°W	EXPRESSVU
ExpressVu, 91°W	EXPRESSTV

Asia

Circular LNB Required

Satellite	Name in Library
Asiasat 4, 122.2°E	ASIASAT
Sinosat 1*, 110.5°E	SINOSAT

* Special LNB required. Call KVH at 1-401-847-3327.

Latin America

Galaxy Circular LNB Required

Satellite	Name in Library
Galaxy 3C, 95°W	GALAXY3CN

Europe

Linear LNB Required

Satellite	Name in Library
Astra 1, 19.2°E	ASTRA1
Astra 2N, 28.2°E	ASTRA2N
Astra 2S, 28.2°E	ASTRA2S
Hispasat, 30.0°W	HISPASAT
Hotbird, 13.0°E	HOTBIRD
Hotbird WB, 13.0°E	HOTBIRDWB
Sirius, 5.0°E	SIRIUS
Thor, 0.8°W	THOR
Arabsat, 26°E	ARABSAT
Nilesat, 7°W	NILESAT
Turksat 1C, 42°E	TURKSAT1C
Eutelsat W3A, 7°E	EUTEL_W3A

Mexico (Sky Mexico Service)

Linear LNB Required

Satellite	Name in Library
PAS 9, 58°W	PAS_9

Australia & New Zealand

Linear LNB Required

Satellite	Name in Library
Optus D1, 160°E	OPTUS_D1
Optus C1, 156°E	OPTUS_C1

D Connecting External Equipment

In addition to TracVision and GPS connections, the ADCU rear panel includes three optional compass outputs of the following formats:

- **One** sine/cosine output
- **Two** serial outputs (each configurable for NMEA 0183, KVH RS-422, or Cetrek)

These compass outputs allow you to supply the GyroTrac sensor's heading data to other electronic devices, such as autopilots, radars, remote displays, plotters, and computers onboard the vessel.

***NOTE:** KVH offers a rotating card display (KVH part #19-0120) for presenting sensor heading information (see Figure 56). This device, powered by 11-40 VDC, connects to any one of the ADCU's serial outputs, configured for NMEA.*

***NOTE:** If you wish to connect a ship's gyro to the system, connect the gyro to the ADCU's GPS input terminals (see Figure 28 on page 15).*

Before you connect an external device, consider the following guidelines:

- The device must comply with NMEA Standard 2.2
- Data conductor wires should be minimum 18 AWG (0.75 mm²), twisted-pair, stranded, tinned marine cable
- Do not use cables with wire diameters larger than 12 AWG (4 mm²), since this is the largest gauge the ADCU can accept
- Always follow the manufacturer's wiring guidelines in the device's manual

This appendix explains how to wire and configure each type of compass output from the ADCU.

Figure 56: Optional Rotating Card Display (Part #19-0120)



D Continued Connecting External Equipment

Sine/Cosine Output

The sine/cosine output can be configured for a 3-wire or 4-wire sine/cosine output, commonly used with ComNav[®], Robertson[®], and other autopilot systems.

Before you connect the external device, consider the following important notes:

- The ADCU's sine/cosine reference voltage is an output, not an input. Do not connect this terminal (#8) to the reference output of the external device.
- If the device has its own internal reference, do not connect the device to the ADCU's reference terminal (#8).
- Before you connect the device's internal ground wire to the ADCU, use a low-impedance voltmeter to verify there is no DC voltage present between the two terminals. A DC surge could damage the electronics.
- The maximum current draw from the ADCU sine/cosine output is 10 mA.
- The B&G 4-wire sine/cosine output (also known as "differential sine/cosine") is a substitute of the Halcyon[®] compass.

Sine/Cosine Output Wiring

In most cases, wire the device to the sine/cosine output as noted below (see Figure 57).

External Device Wire:	Connect to Green ADCU Terminal:
Sine	12
Cosine	10
Internal power ground (not chassis ground)	7
Reference (input)	8 (KVH output)

Figure 57: Sine/Cosine ADCU Wiring

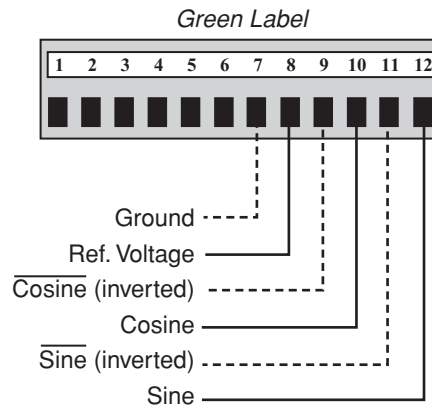

D Continued Connecting External Equipment

Sine/Cosine Output Configuration

Once you have finished the system installation, configure the ADCU's sine/cosine output for the desired heading format and the correct voltages for the external device.

1. Press the center **MENU** button on the ADCU to access the onscreen menu (see Figure 58).
2. At "Setup display type?", press **NEXT** until the display shows "Setup data outputs?" Then press **ENTER** and press **YES** to confirm.
3. At "Set sine-cos levels?", press **YES**.
4. Now you need to select the desired heading format. At "Sine cosine is", press **MAG** to select magnetic heading, or press **TRUE** to select true heading. Then press **ENTER**.

IMPORTANT!

If you did not connect a GPS to the system, only magnetic heading is available. If you connected a ship's gyro to the system, only true heading is available.

5. At "Set Ref", use the - and + buttons to set the reference voltage (0 - 6.5 volts). Then press **ENTER**.

TIP: If you do not know the correct reference voltage for the external device, connect a voltmeter between the ADCU's reference terminal (#8) and the reference terminal on the external device. Then simply adjust the reference voltage on the ADCU until the voltmeter indicates zero volts (0 VDC).

NOTE: If you are using a B&G 4-wire sine/cosine output as a substitute for a Halcyon compass, set the reference voltage to 3.5 volts.

6. At "Set Swing", use the - and + buttons to set the swing voltage ($\pm 0 - 6.5$ volts). Then press **ENTER**.

Figure 58: Sine/Cosine Output Configuration Menus on ADCU

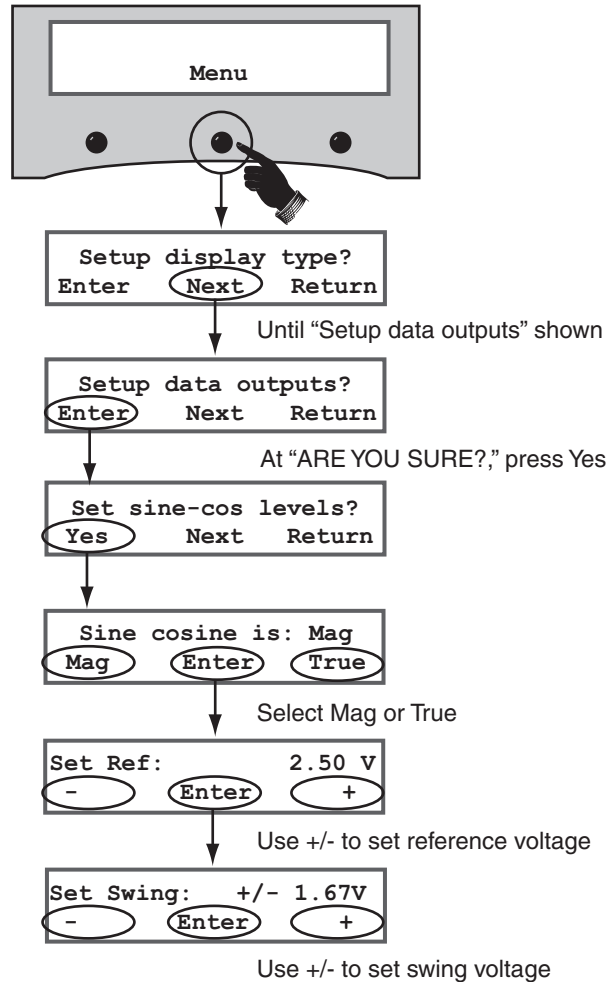

D Continued Connecting External Equipment

Serial Outputs

The two serial outputs (#1 and #2) can be individually configured for any of the following output types:

Type	Description
NMEA	<ul style="list-style-type: none"> Conforms to NMEA 0183 version 2.20 standard Selectable formats: BWC, GGA, GLL, HDG, HDM, HDT, VTG, and XTE KVH rotating card display requires this output type
KVH RS-422	<ul style="list-style-type: none"> Supplies stabilized pitch, roll, and yaw data Serial port #1 at 4800 baud; Serial port #2 at 4800 or 9600 baud Usable in any device that can receive this data rate
Cetrek	<ul style="list-style-type: none"> Proprietary format Supplies stabilized heading data to a Cetrek autopilot device

Serial Output Wiring

Connect the external device(s) to the desired ADCU serial output(s), as shown in Figure 59 and Figure 60.

NOTE: The ADCU also provides a pass-through duplicate of serial port #1 (see Figure 61).

IMPORTANT!

The ADCU's third serial output is disabled when the sensor is connected to a TracVision system. Serial port #3 is only used in a standalone GyroTrac installation.

Figure 59: Serial Port #1 ADCU Wiring

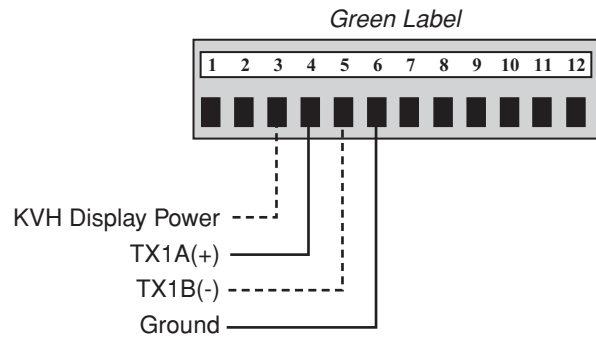

Figure 60: Serial Port #2 ADCU Wiring

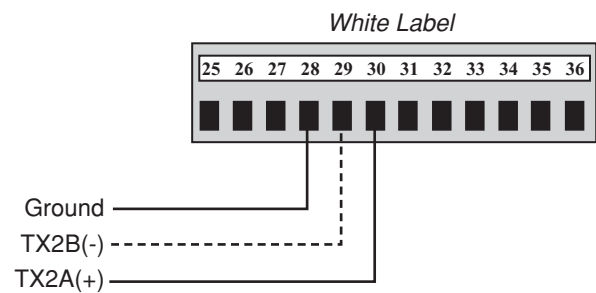
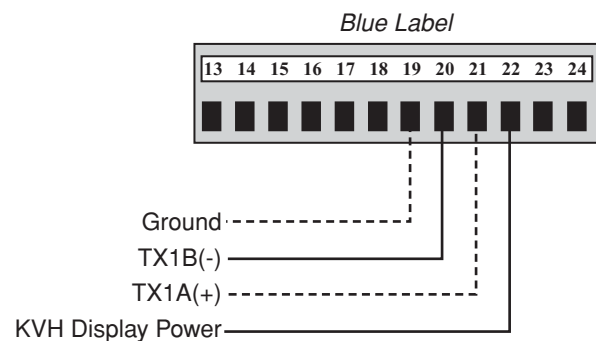

Figure 61: Duplicate Serial Port #1 ADCU Wiring



D Continued Connecting External Equipment

Serial Output Configuration

Once you have finished the system installation, configure the ADCU's serial outputs for the desired port speed and output type.

1. Press the center **MENU** button on the ADCU to access the onscreen menu (see Figure 62).
2. At "Setup display type?", press **NEXT** until the display shows "Setup data outputs?" Then press **ENTER** and press **YES** to confirm.
3. At "Set sine-cos levels?", press **NEXT** until the display shows "Set serial outputs?" Then press **YES**.
4. At "Select serial port", press **NEXT** until the display shows the serial port number you want to configure (1 or 2). Then press **YES**.
5. At "Set Speed", use the - and + buttons to set the speed of the serial port (1 Hz - 20 Hz). Then press **ENTER**.
6. At "Resetting outputs?", press **YES**.
7. Now you need to set the output type for the selected serial port. At "Select output type", press **NMEA**, **KVH**, or **CETREK** to select the corresponding output type.
8. If you selected NMEA, select the desired NMEA message format(s). At "Select output", press **NEXT** until the display shows the desired format (BWC, GGA, GLL, HDG, HDM, HDT, VTG, or XTE). Then press **YES**. You may select as many messages as you wish. When you are done, press **CANCEL**.
9. If you selected Cetrek, and a GPS is connected, select the desired heading format. At "Cetrek data is", press **MAG** to select magnetic heading, or press **TRUE** to select true heading. Then press **ENTER**.

NOTE: The baud rate for serial port #1 is always set to 4800 baud. The baud rate for serial port #2 is automatically set to 4800 baud (NMEA or Cetrek) or 9600 baud (KVH RS-422).

Figure 62: Serial Port Configuration Menus on ADCU

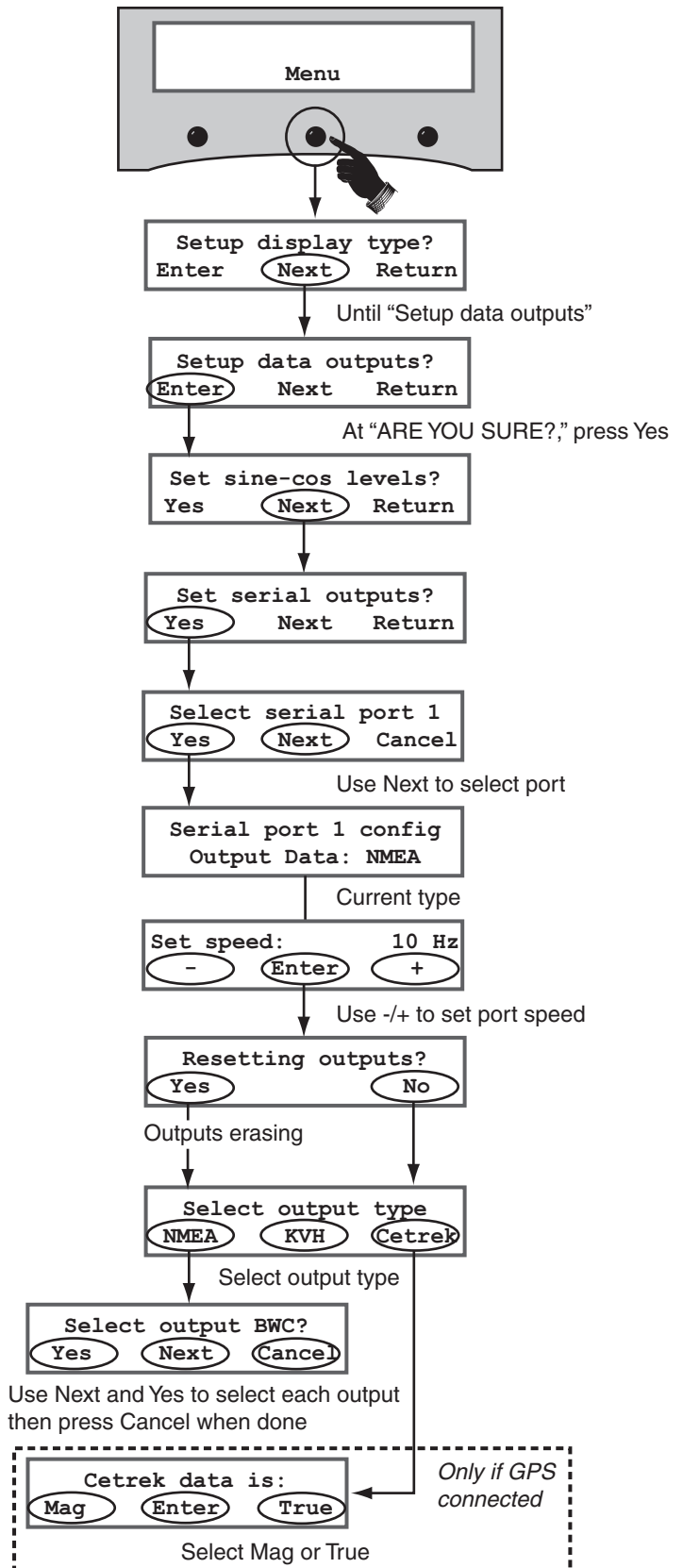

D Continued Connecting External Equipment

Serial Output Message Formats

This section shows various serial message formats for easy reference.

NMEA1 Magnetic Heading (HDM) Format

Communication: 4800 baud, 1 start bit, 8 data bits, 1 stop bit, no parity

Update rate: 1-20 Hz, selectable

Sentence type: \$HCHDM,XXX.X,M,*hh<cr><lf>

HCHDM	NMEA talker and sentence ID
XXX.X	Stabilized magnetic heading in degrees and tenths
M	Mag. heading, ASCII hex 0x4D
*	ASCII hex 0x2A
hh	Checksum
<cr>	Carriage return, ASCII hex 0x0D
<lf>	Line feed, ASCII hex 0x0A

NMEA2 Magnetic Heading (HDG) Format

Communication: 4800 baud, 1 start bit, 8 data bits, 1 stop bit, no parity

Update rate: 1-20 Hz, selectable

Sentence type: \$HCHDG,XXX.X,*hh<cr><lf>

HCHDG	NMEA talker and sentence ID
XXX.X	Stabilized magnetic heading in degrees and tenths
*	ASCII hex 0x2A
hh	Checksum
<cr>	Carriage return, ASCII hex 0x0D
<lf>	Line feed, ASCII hex 0x0A

NMEA3 True Heading (HDT) Format

Communication: 4800 baud, 1 start bit, 8 data bits, 1 stop bit, no parity

Update rate: 1-20 Hz, selectable

Sentence type: \$HCHDT,XXX.X,T,*hh<cr><lf>

HCHDT	NMEA talker and sentence ID
XXX.X	Stabilized true heading in degrees and tenths
T	True heading, ASCII hex 0x54
*	ASCII hex 0x2A
hh	Checksum
<cr>	Carriage return, ASCII hex 0x0D
<lf>	Line feed, ASCII hex 0x0A

KVH Special RS-422 Format (Set at factory only)

Communication: 9600 baud, 1 start bit, 8 data bits, 1 stop bit, no parity

Update rate: 1-20 Hz, selectable

Sentence type: %AAAA,BBBB,CCCC<cr><lf>

%	Sentence ID
AAAA	Stabilized pitch attitude in tenths of degrees
BBBB	Stabilized roll attitude in tenths of degrees
CCCC	Stabilized magnetic azimuth in tenths of degrees
<cr>	Carriage return, ASCII hex 0x0D
<lf>	Line feed, ASCII hex 0x0A

D Continued Connecting External Equipment

Cetrek Format

Communication: 4800 baud, 1 start bit, 8 data bits, 1 stop bit, no parity

Update rate: 1-20 Hz, selectable

Sentence type: \$\$MSB LSB B C Status D<cr><lf>

MSB LSB	Binary value 0-1023, equal to 0.0-359.6 degrees stabilized magnetic heading
B	ASCII hex 0x00
C	ASCII hex 0x00
Status	ASCII hex 0x43
D	ASCII hex 0xAA
<cr>	Carriage return, ASCII hex 0x0D
<lf>	Line feed, ASCII hex 0x0A

E Entering Sensor Offset Values

The GyroTrac sensor must be located as close to level in pitch and roll as possible, with its long axis parallel to the vessel's centerline (see Figure 20 on page 11). If you are unable to mount the sensor according to these guidelines, follow these steps to set offset values to compensate for minor variances in the sensor's pitch, roll, and yaw.

NOTE: The maximum offset for pitch and roll is $\pm 45^\circ$. The maximum offset for yaw is $\pm 180^\circ$.

IMPORTANT!

This procedure must be performed while the vessel is stopped in calm water.

Step 1 - Note the Reported Pitch and Roll

First you need to determine the pitch and roll values that the sensor is currently reporting.

1. Press the center **MENU** button on the ADCU to access the onscreen menu (see Figure 63).
2. At "Setup display type?", press **ENTER**.
3. At "Compass?", press **NEXT** until the display shows "Pitch, Roll & Yaw." Then press **YES**.
4. Write down the reported pitch and roll, but reverse the sign (for example, a positive number becomes negative). These are the offsets you need to enter for pitch and roll in the next step.

Figure 63: Pitch, Roll & Yaw Display on ADCU

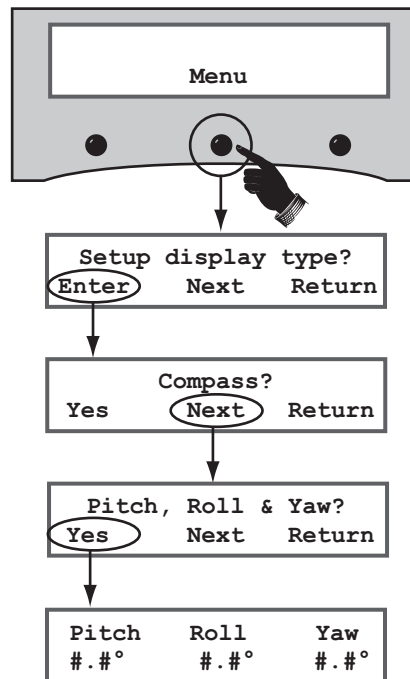

E Continued Entering Sensor Offset Values

Step 2 - Enter the Gyro Offsets

Now you need to enter the offsets (which you determined in Step 1) into the antenna.

1. Press the center **MENU** button on the ADCU to access the onscreen menu (see Figure 64).
2. At "Setup display type?", press **NEXT** until the display shows "Setup Configuration?". Then press **ENTER** and press **YES** to confirm.
3. At "Set brightness?", press **NEXT** until the display shows "Set Gyro offsets?"
4. At "Set Gyro offsets?", press **YES**.
5. At "Set offset Pitch?", press **YES** to go to the Pitch screen. (Later, you will press **NEXT** to go to the Roll or Yaw screen instead.)
6. At "Set Pitch", use the - and + buttons to set the pitch offset value. Then press **ENTER**.
7. Repeat Steps 4 through 6 to set the roll and yaw offset values.

Figure 64: Gyro Offset Menus on ADCU

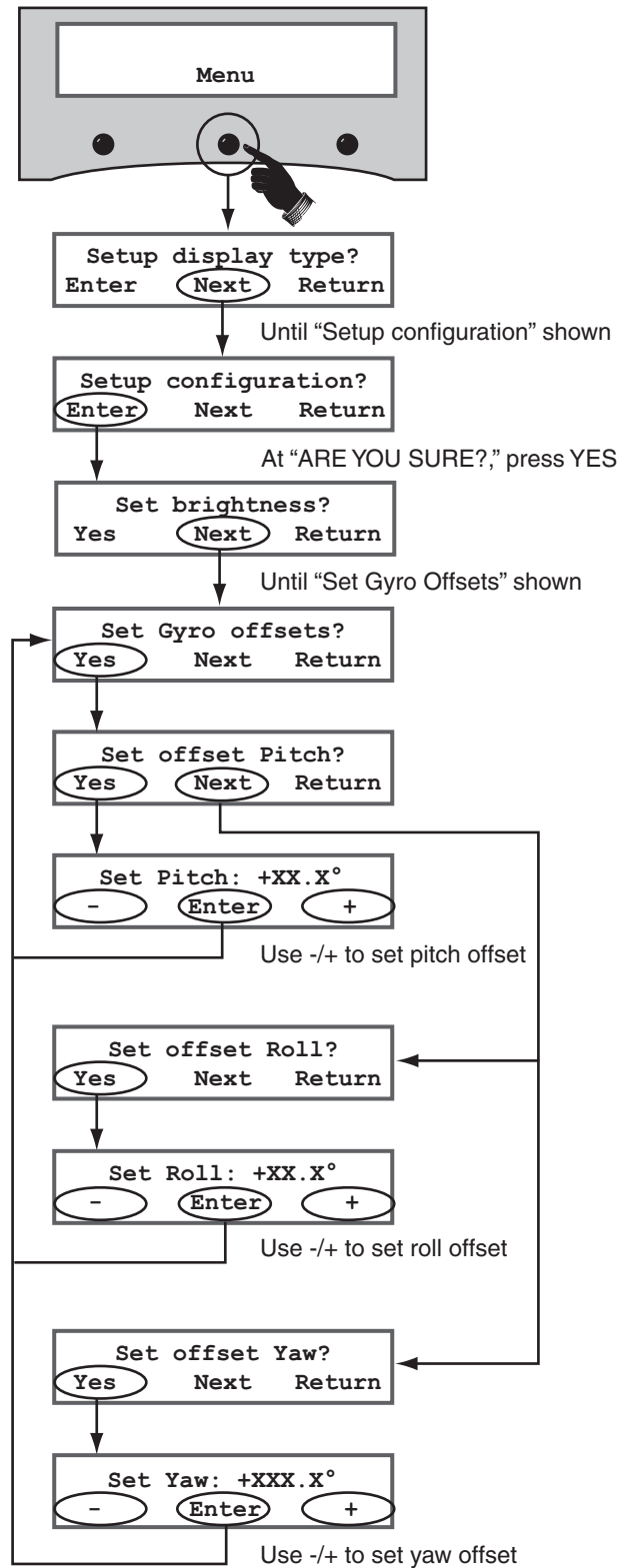

F Clearing the Calibration Score

If you needed to relocate the sensor after performing an initial calibration, follow these steps to clear the calibration score. You need to clear the system's stored calibration data before you can calibrate the sensor for a new location.

1. Press the center **MENU** button on the ADCU to access the onscreen menu (see Figure 65).
2. At "Setup display type?", press **NEXT** until the display shows "Control compass?" Then press **ENTER** and press **YES** to confirm.
3. At "Set AutoCal On/Off?", press **NEXT** until the display shows "Clear COMPASS cal?" Then press **YES** and press **YES** again to confirm.
4. Wait a few seconds while the Autocalibration function resets.
5. When the display shows "AutoCal reset done", turn off the TracVision system.
6. Wait 10 seconds, then turn on the TracVision system.

Figure 65: Clear Compass Cal Menus on ADCU

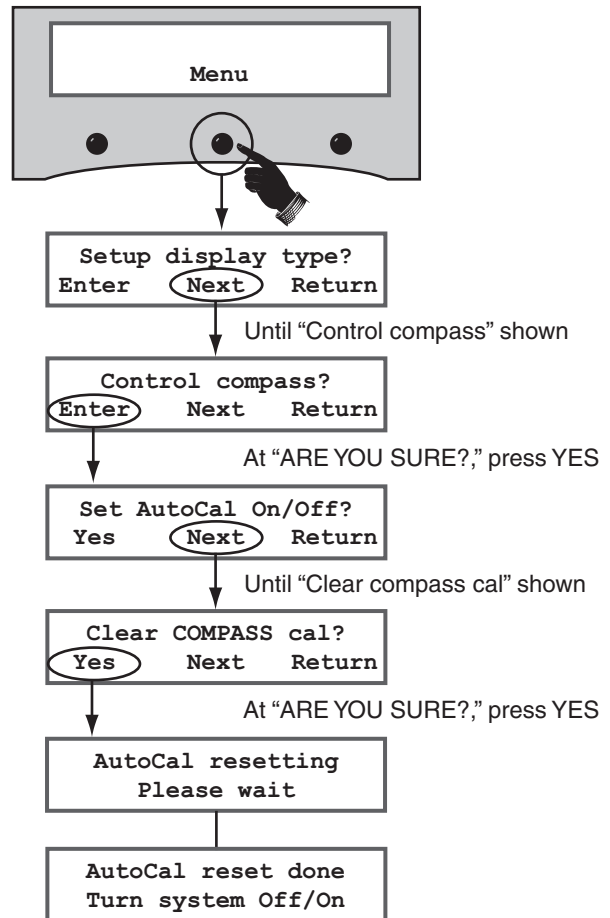

G Position Grids

If the vessel is located in Europe or North America, you may use the appropriate grid and table below to determine your approximate latitude and longitude.

Europe

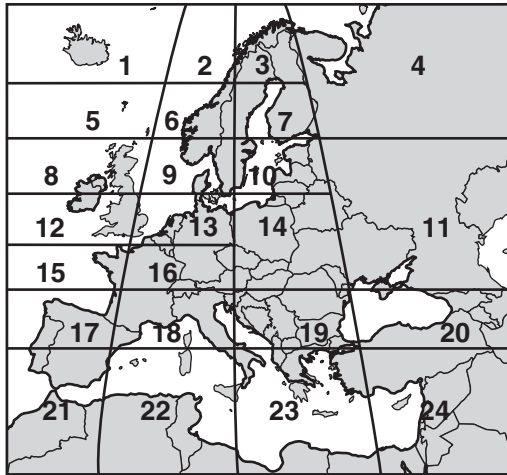

Grid #	Latitude	Longitude
1	67° N	7° W
2	67° N	7° E
3	67° N	22° E
4	65° N	45° E
5	63° N	7° W
6	63° N	7° E
7	63° N	22° E
8	57° N	7° W
9	57° N	7° E
10	57° N	22° E
11	55° N	40° E
12	53° N	7° W
13	53° N	7° E
14	50° N	22° E
15	47° N	7° W
16	47° N	7° E
17	43° N	7° W
18	43° N	7° E
19	43° N	22° E
20	43° N	37° E
21	36° N	7° W
22	36° N	7° E
23	36° N	22° E
24	36° N	37° E

North America

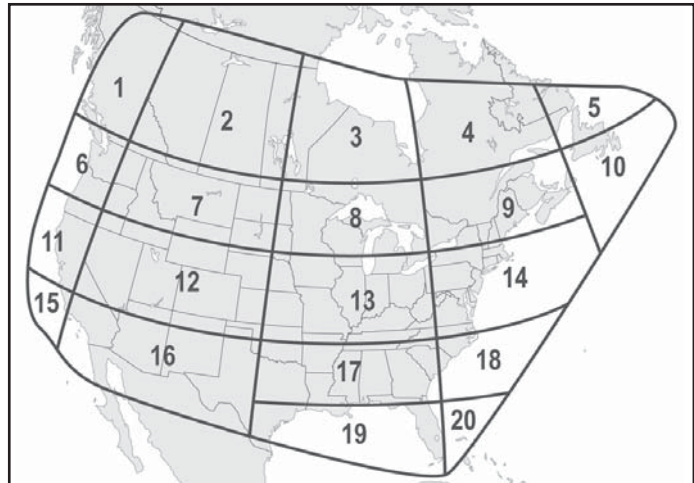

Grid #	Latitude	Longitude
1	55° N	125° W
2	55° N	110° W
3	55° N	90° W
4	55° N	70° W
5	55° N	55° W
6	45° N	125° W
7	45° N	110° W
8	45° N	90° W
9	45° N	70° W
10	45° N	50° W
11	40° N	125° W
12	40° N	110° W
13	40° N	90° W
14	40° N	70° W
15	32° N	125° W
16	32° N	110° W
17	32° N	90° W
18	32° N	75° W
19	27° N	83° W
20	27° N	78° W

H Wiring Diagrams

ADCU Wiring - Required

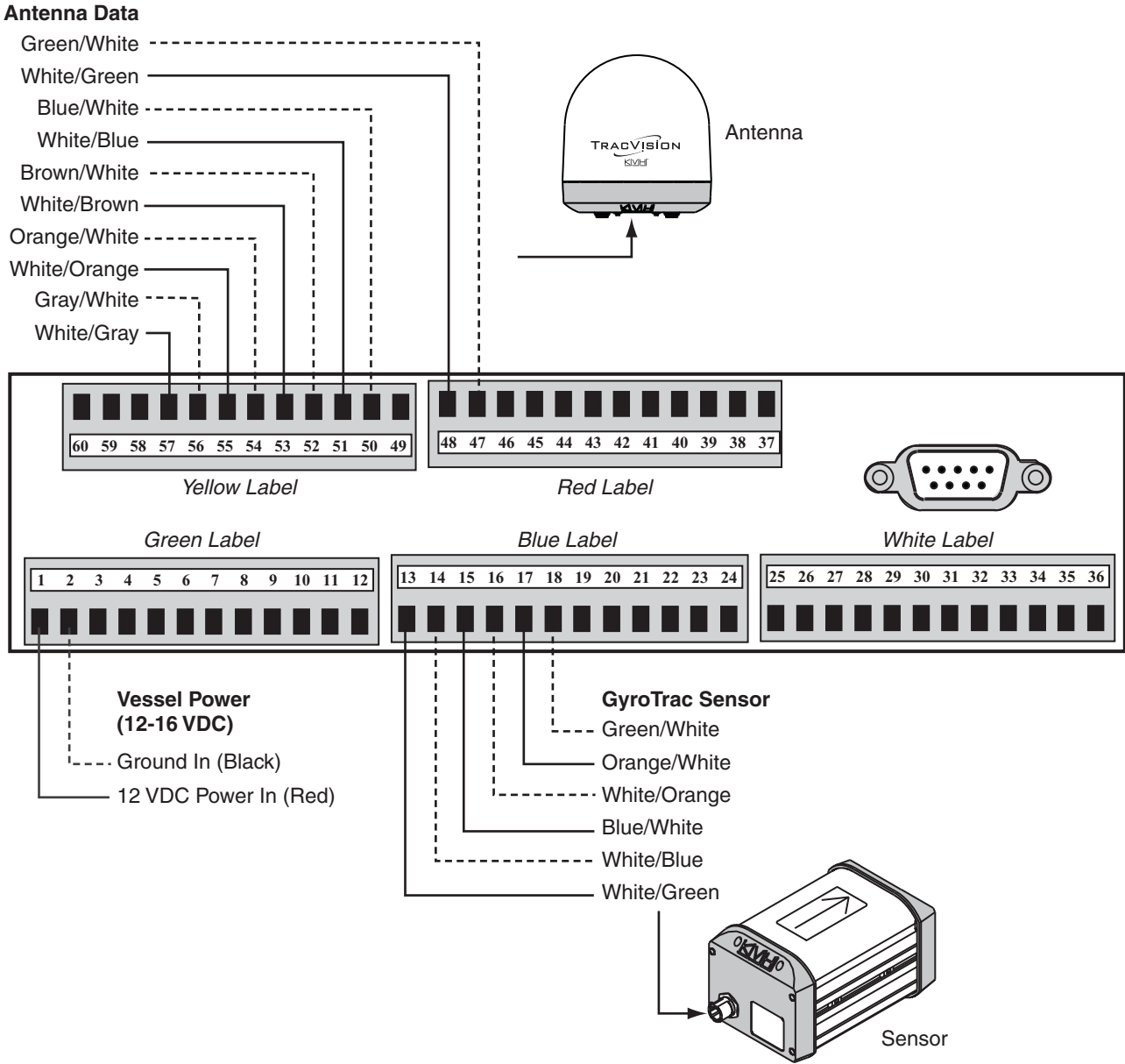

NOTE: The diagrams refer to wires by **body color/stripe color**. For example, "Blue/White" means the blue wire with white stripe.

H Wiring Diagrams

ADCU Wiring - Optional

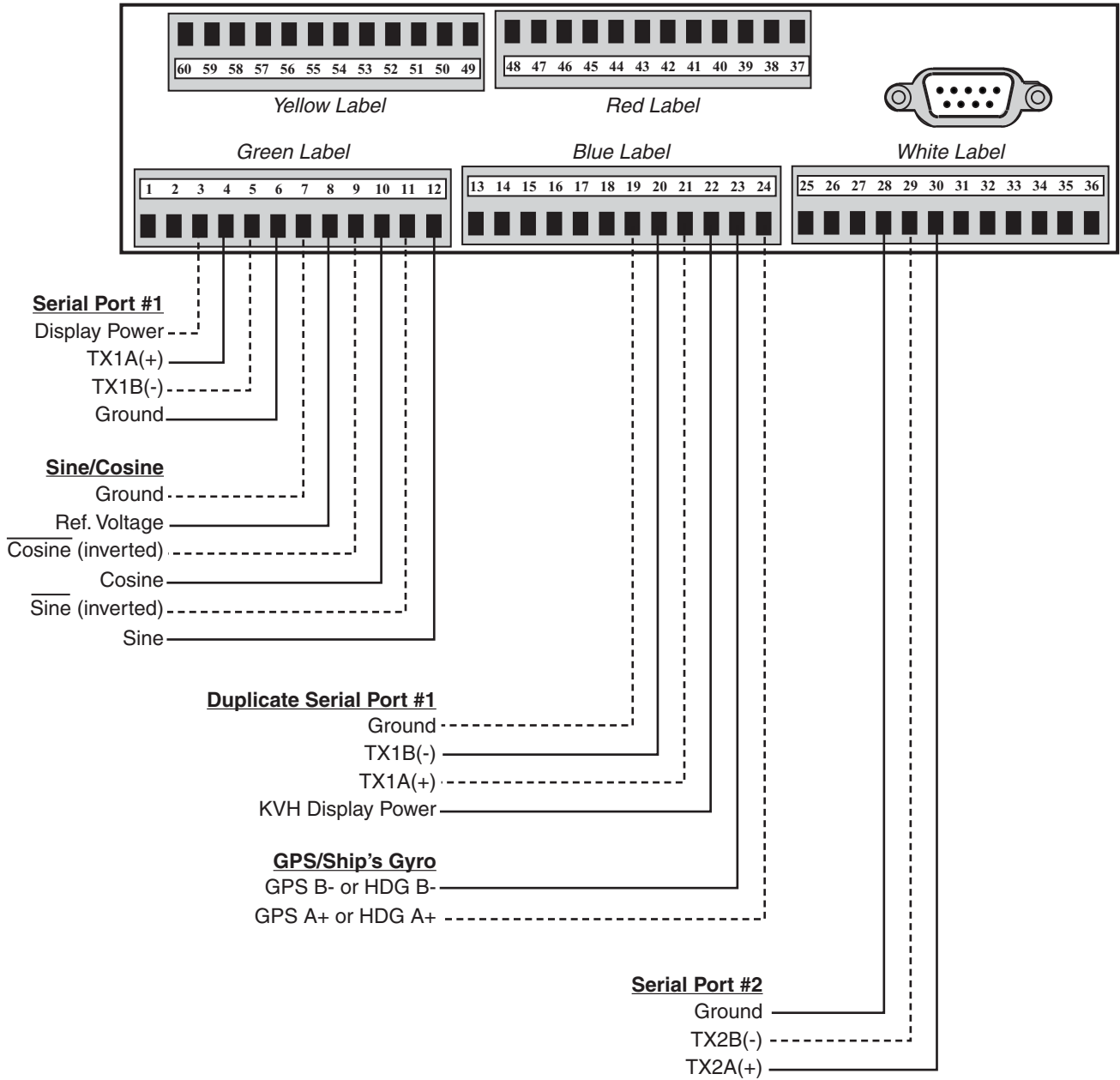

H Wiring Diagrams

Basic Wiring - 1 or 2 Receivers

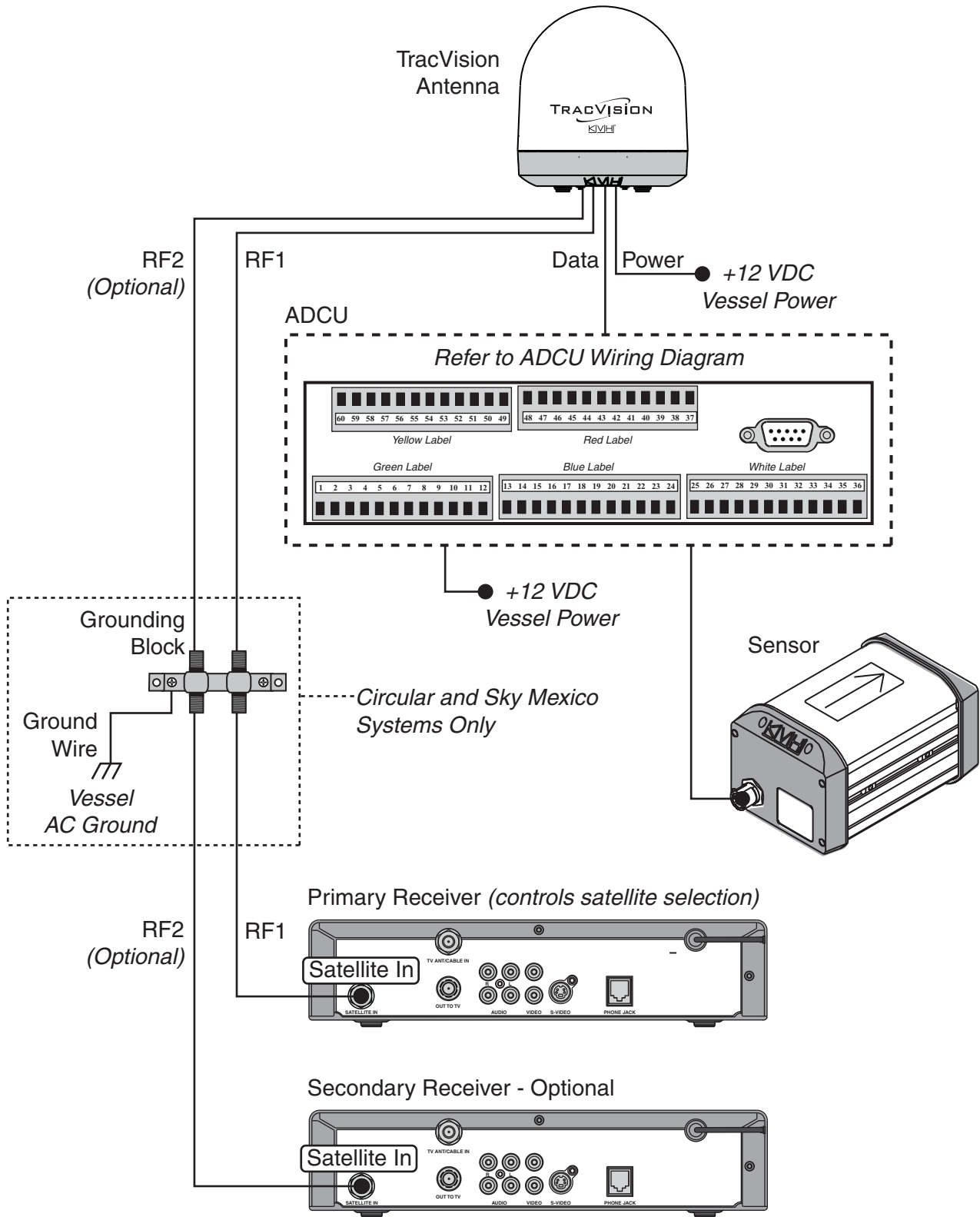

ADCU Flush Mounting Template

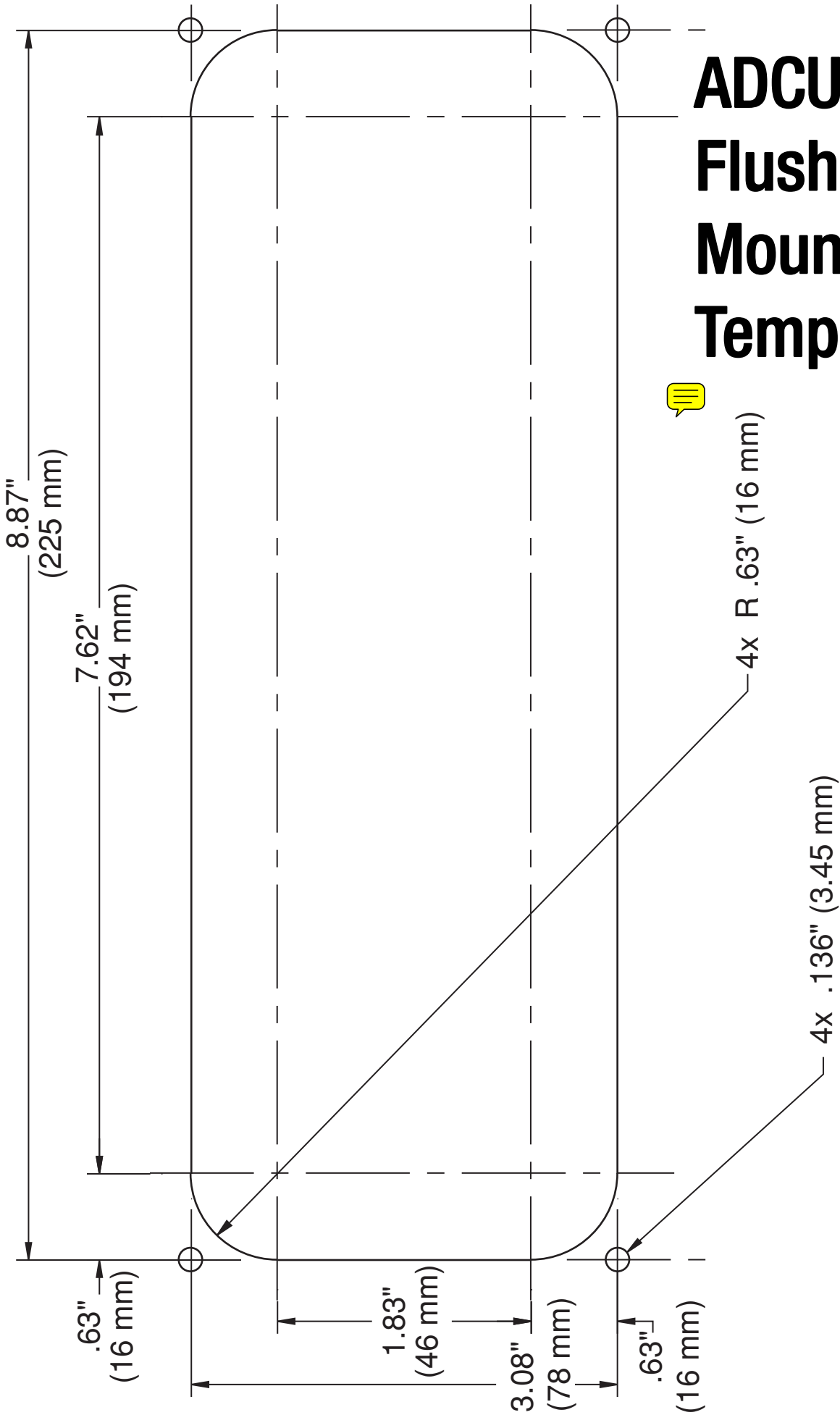



KVH Industries, Inc.

50 Enterprise Center Middletown, RI 02842-5279 U.S.A.
Phone: +1 401 847-3327 Fax: +1 401 849-0045
E-mail: info@kvh.com Internet: www.kvh.com

KVH Europe A/S

Kokkedal Industripark 2B 2980 Kokkedal Denmark
Phone: +45 45 160 180 Fax: +45 45 160 181
E-mail: info@kvh.dk Internet: www.kvh.com