

TRACVISION[®]
BY KVH INDUSTRIES

TracVision M5 Switchplate Configuration



TracVision M5 Installation Guide

TracVision[®] M5 Installation Guide

Switchplate Configuration

These instructions explain how to install the TracVision M5 satellite TV antenna system on a vessel. Complete instructions on how to use the system are provided in the *User's Guide*.

Installation Steps

- | | | | |
|---|----|--|----|
| 1. Inspect Parts and Get Tools | 3 | 10. Connect Power | 13 |
| 2. Plan the Antenna Installation | 4 | 11. Mount the Switchplate | 14 |
| 3. Plan the Belowdecks Installation | 5 | 12. Connect a Laptop to the Antenna... | 15 |
| 4. Prepare the Antenna Site..... | 6 | 13. Select Satellites..... | 16 |
| 5. Remove the Restraints | 7 | 14. Enter Your Latitude & Longitude .. | 18 |
| 6. Wire the Antenna | 8 | 15. Run Check Switch Tests..... | 19 |
| 7. Mount the Antenna | 9 | 16. Set the LNB Skew Angle | 21 |
| 8. Wire the Switchplate | 10 | 17. Educate the Customer | 22 |
| 9. Wire the Receiver(s) | 11 | | |

Who Should Install the System?

To ensure a safe and effective installation, KVH recommends that a KVH-authorized marine technician install the TracVision antenna. KVH-authorized technicians have the tools and electronics expertise necessary to install the system. To find a technician near you, visit www.kvh.com/wheretogetservice.

Linear vs. Circular Systems

The installation process differs slightly depending on the type of LNB (low noise block) that is installed in the antenna (linear or circular). These differences are noted throughout this manual. Appendix B on page 27 notes the satellites available for each LNB type and geographic region.

Technical Support

If you need technical assistance, please contact KVH Technical Support:

North/South America, Australia:
Phone: +1 401 847-3327
E-mail: techs@kvh.com
(Mon.-Fri., 9 am-6 pm ET, -5 GMT)
(Sat., 9 am-2 pm ET, -5 GMT)

Europe, Middle East, Asia:
Phone: +45 45 160 180
E-mail: support@kvh.dk
(Mon.-Fri., 8 am-4:30 pm, +1 GMT)

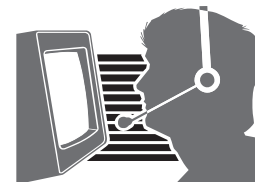

1 Inspect Parts and Get Tools

Before you begin, follow these steps to make sure you have everything you need to complete the installation.

- a. Unpack the box and ensure it contains everything shown on the *Kitpack Contents List*. Save the packaging for future use.

IMPORTANT!

Always lift the antenna by the baseplate and never by the radome or any portion of the internal antenna assembly (see Figure 1).

- b. Carefully examine all of the supplied parts to ensure nothing was damaged in shipment.
- c. Gather all of the tools and materials listed below. You will need these items to complete the installation.
 - Flat-head and Phillips-head screwdrivers
 - Electric drill and 3/8" (10 mm), 5/32" (4 mm), and 3/32" (2.25 mm) drill bits
 - 3" (80 mm) hole saw
 - Socket wrenches
 - 7/16" open-end wrench
 - Torque wrench (*Linear systems only*)
 - Light hammer and center punch
 - Adhesive tape and scribe or pencil
 - Wire strippers and terminal lug crimper
 - 2 mm allen hex key (*Linear systems only*)
 - RG-6 or RG-11 RF coax cable(s) with Snap-N-Seal® F-connectors (see Step 6a)
 - Augat IT1000 connector installation tool
 - Power cable (see Figure 2)
 - Silicone sealant, self-vulcanizing tape, or equivalent
 - Satellite TV receiver and TV (see Figure 3 for a list of validated U.S./Canadian receivers)
 - Windows® laptop PC with Windows HyperTerminal or KVH Flash Wizard

Figure 1: TracVision M5 System Components

Antenna

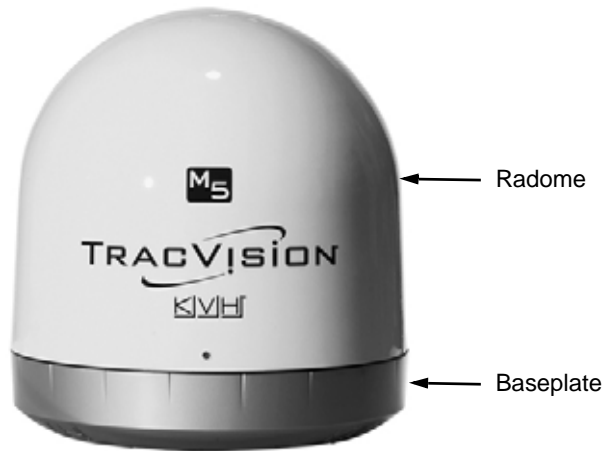

Switchplate



Figure 2: Power Cable Guidelines

Cable Length	Use Cable Gauge
< 40 ft (12 m)	14AWG (2.5mm ²)
40-70 ft (12-21 m)	12AWG (4mm ²)

Figure 3: KVH-Validated U.S./Canadian Receivers

Standard-Definition Models		
DIRECTV	DISH Network	Bell TV
D12	311	4100
D11	211k	3100
D10	211	
High-Definition (HD) Models		
DIRECTV	DISH Network	Bell TV
HD not supported	211k 211	6100 6131

2 Plan the Antenna Installation

Consider the following antenna installation guidelines:

- Minimize blockage. The antenna requires a clear view of the sky to receive satellite TV (see Figure 4). The fewer obstructions, the better the system will perform.
- Make sure the mounting surface is wide enough to accommodate the antenna's base (see Figure 5). Also make sure it is flat, level (within $\pm 1^\circ$), strong enough to support the antenna's weight (30 lbs, 13.6 kg), and rigid enough to withstand vibration.
- Select a location that is as close as possible to the intersection of the vessel's fore-and-aft centerline and midships.
- Do not mount the antenna at the same level as the radar because the radar's energy might overload the antenna. Ideally, you should mount the antenna 4 ft (1.2 m) above the radar, outside the beam path of the radar.

IMPORTANT!

Be sure to follow the guidelines above. Damage caused by an improper installation is not covered under KVH warranty.

Figure 4: Blockage from Obstruction

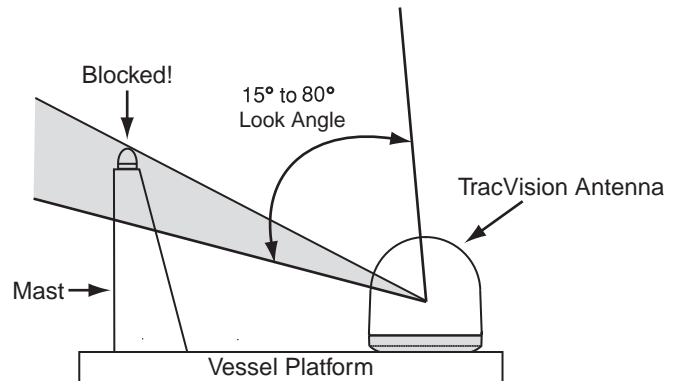
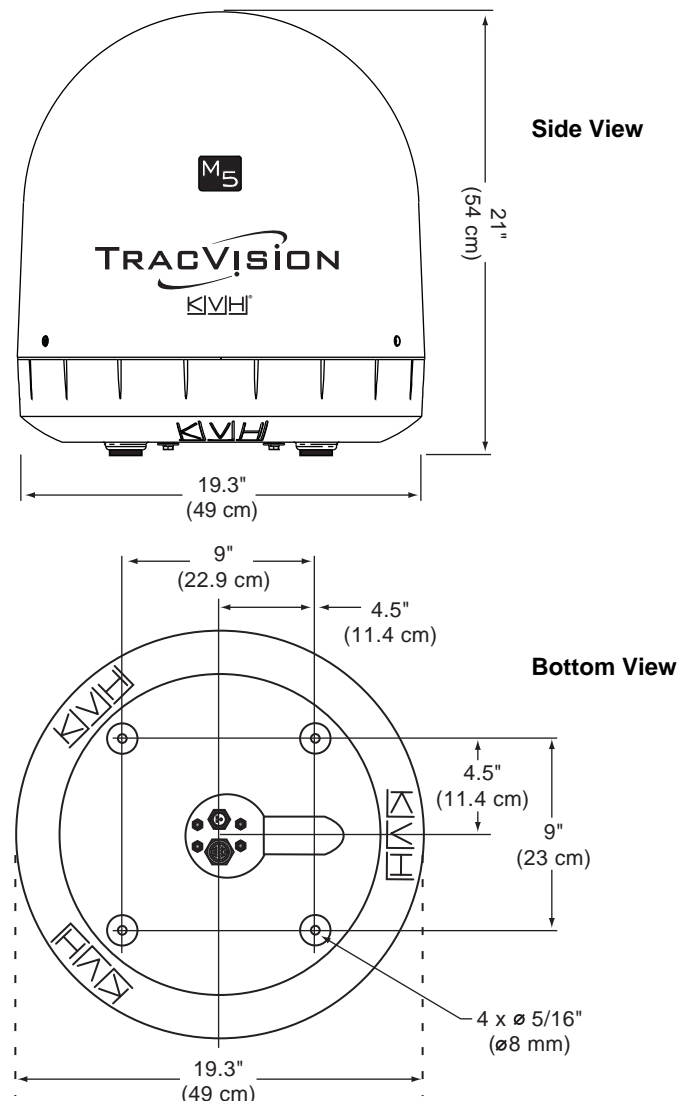

Figure 5: Antenna Dimensions



4

Prepare the Antenna Site

Once you have identified a suitable antenna mounting site, according to the guidelines provided on page 4, follow these steps to drill the mounting holes and cable access hole to prepare the site for installation.

- a. Unfold the antenna mounting template (supplied in the Customer Welcome Kit) and place it onto the mounting surface. Make sure the “FWD” (forward) arrow points toward the bow and is parallel to the vessel’s centerline (see Figure 8).

NOTE: You don’t need to mount the antenna exactly on the vessel’s centerline (the closer, the better), but the antenna’s forward arrow must be parallel to it.

- b. Using a light hammer and center punch, mark the locations for the four mounting holes and cable access hole on the mounting surface in the locations indicated on the template.
- c. Drill a 3/8" (10 mm) hole at the four mounting hole locations you marked in Step b. Later, you will insert four 1/4"-20 bolts through these holes to secure the antenna to the mounting surface.
- d. Cut out the 3" (80 mm) cable access hole in the location you marked in Step b. Smooth the edges of the hole to protect the cables. Later, you will route the data, power, and RF cables through this hole and into the vessel.
- e. Clean and dry the antenna mounting surface.
- f. Peel off the paper backing from the supplied foam seal to expose the adhesive. Then press the foam seal down firmly onto the mounting surface, ensuring the narrow end points toward the bow and the hole in the foam seal aligns with the cable access hole in the mounting surface (see Figure 9).

NOTE: Apply the foam seal to the vessel mounting surface, not to the antenna’s baseplate. You will have difficulty connecting the cables to the antenna if the foam seal is attached to the baseplate.

Figure 8: Antenna Mounting Holes Layout

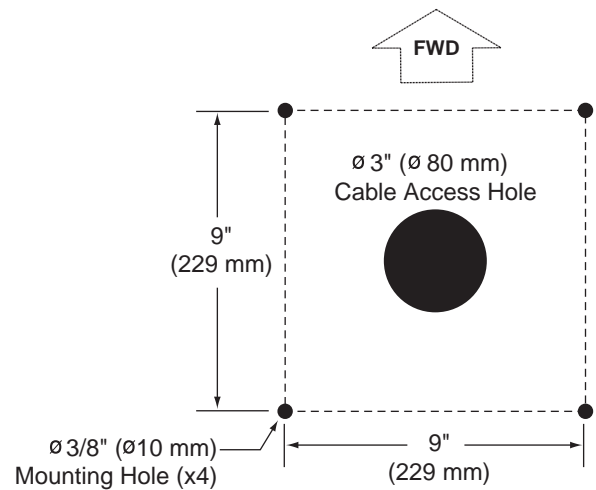
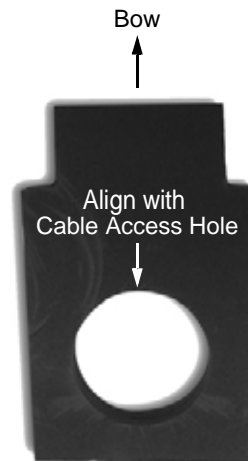

Figure 9: Foam Seal



5 Remove the Restraints

Inside the antenna, a foam block and two bolts prevent the antenna assembly from moving during shipment. Follow these steps to remove these shipping restraints.

- a. Remove the three #10-24 Phillips screws securing the radome to the baseplate. Carefully lift the radome straight up until clear of the antenna assembly and set it aside in a safe place.

TIP: If you keep the radome topside, secure it with a lanyard to prevent it from falling overboard.

- b. Remove the foam block that is wedged beneath the antenna's reflector (see Figure 10). Save this restraint for future use; the customer will need to reinstall it if he/she needs to relocate or reship the antenna.
- c. Using a 10 mm socket wrench, remove the two bolts, washers, and spacers securing the antenna assembly to the baseplate (see Figure 11 and Figure 12). Save these restraints for future use.

IMPORTANT!

Once you have removed the restraints, keep the antenna level as much as possible and handle the antenna very carefully. Prevent the internal antenna assembly from rotating freely within the baseplate to avoid damaging the limit switch.

Figure 10: Foam Block Shipping Restraint

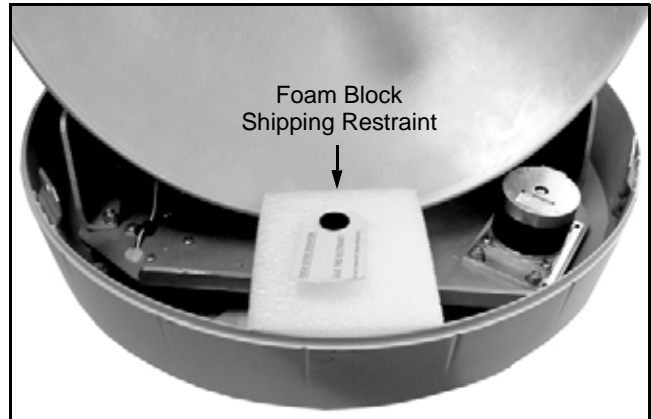

Figure 11: Shipping Restraint Hardware

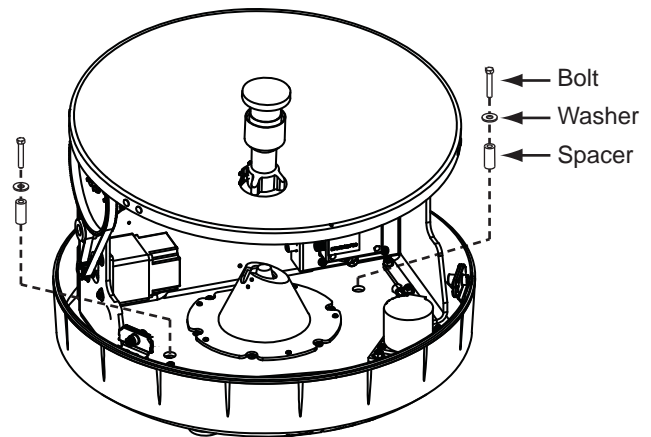

Figure 12: Removing the Shipping Restraint Bolts



6 Wire the Antenna

Follow these steps to connect the data, power, and RF cables to the antenna.

- a. First determine the number of RF coax cables you need to connect to the antenna for your particular installation (see Figure 13). (See Figure 14 to determine the type of cable required.)
- b. Route the data, power, and RF cables belowdecks through the 3" (80 mm) cable access hole. Leave an adequate service loop, approximately 8" (20 cm) of slack, in the cables for easy serviceability. Later, you will connect the data and power cables to the switchplate and the RF cable(s) to the receiver(s).
- c. Connect the data cable to the "Data" connector on the bottom of the antenna (see Figure 15). Hand-tighten until the cable locks in place; do not use excessive force.
- d. Connect the power cable to the "Power" connector on the bottom of the antenna. Hand-tighten until the cable locks in place; do not use excessive force.
- e. Connect the RF coax cable(s) to the antenna. If you need to connect just one RF cable, connect the cable to the "RF1" connector on the bottom of the antenna. Hand-tighten, then tighten with a 7/16" wrench for 1/4 turn to ensure an electrical connection. Connect any additional RF coax cables to the antenna's RF2, RF3, and RF4 connectors, in that order.

TIP: If you connect two or more RF cables, label both ends of each cable to match the connector. This will make it easier to identify the cables later.

- f. Seal the RF cable connections with silicone sealant, self-vulcanizing tape, or equivalent.

Figure 13: Number of RF Coax Cables to Connect to Antenna

Connecting to:	# RF Cables
<i>System with Circular Dual LNB</i>	
1 receiver	1
2 or more receivers	2*
<i>System with Linear Dual LNB</i>	
1 receiver	1
2 receivers	2*
<i>System with Linear Quad LNB</i>	
1 receiver	1
2 receivers	2
3 receivers	3
4 or more receivers	4*

* Multiswitch required for additional receivers.

Figure 14: RF Cable Guidelines

Cable Length	Use Cable Type
<= 75 ft (23 m)	RG-6
> 75 ft (23 m)	RG-11

Figure 15: Connectors on Bottom of Antenna

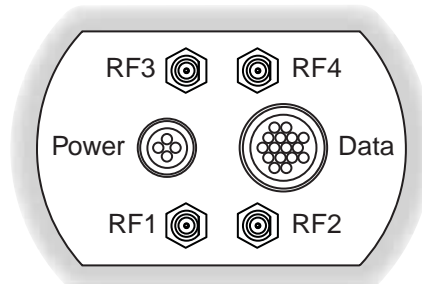

7 Mount the Antenna

Follow these steps to mount the antenna to the mounting surface.

- a. Place the antenna baseplate over the holes drilled in the mounting surface. Ensure the “Forward” arrow inside the baseplate points toward the bow and is parallel to the vessel’s centerline (see Figure 16).

IMPORTANT!

You will need to rotate the antenna assembly by hand to see all four mounting holes. Rotate the antenna assembly slowly. If it hits a mechanical stop with excessive force, the limit switch might become damaged.



CAUTION

Observe the safety warnings printed on the tube of Loctite® anti-seize lubricant: “Contains mineral oil, calcium hydroxide, and copper. May cause skin, eye, and respiratory irritation. Wear eye protection and gloves. **First aid:** In case of eye or skin contact, flush with water. Obtain medical attention for any eye or internal contact.”

- b. Apply a thin layer of the supplied anti-seize lubricant to the threads of the four 1/4"-20 bolts to prevent galling.
- c. At each of the four baseplate mounting holes, place a 1/4" flat washer on a 1/4"-20 bolt and insert the bolt into the hole from above (see Figure 17). Secure each mounting bolt to the mounting surface using a 1/4" flat washer and a 1/4"-20 lock nut from below. Tighten all four bolts until the four rubber feet on the baseplate are bottomed against the mounting surface and the foam seal is fully compressed.

TIP: If you are installing a linear system, keep the radome off for now. You will need to adjust the skew angle of the antenna’s LNB.

- d. Reinstall the radome onto the antenna. Secure in place with the three #10-24 screws you removed in Step 6a (see Figure 18). Install a protective plastic screw cap (supplied in the kitpack) over each screw.

Figure 16: “Forward” Arrow in Antenna Baseplate

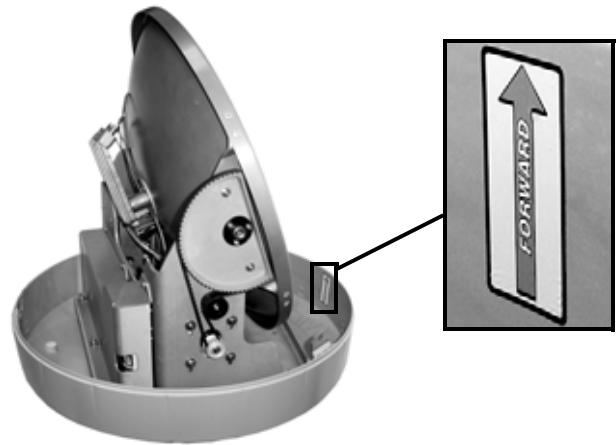

Figure 17: Mounting the Antenna (Side View)

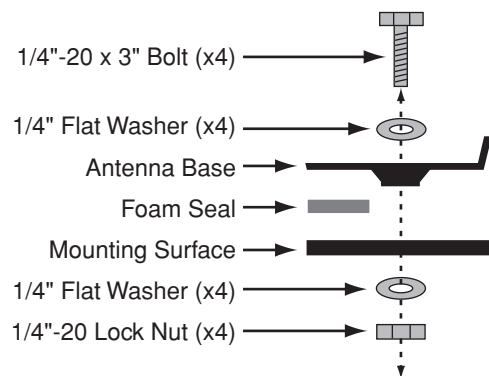
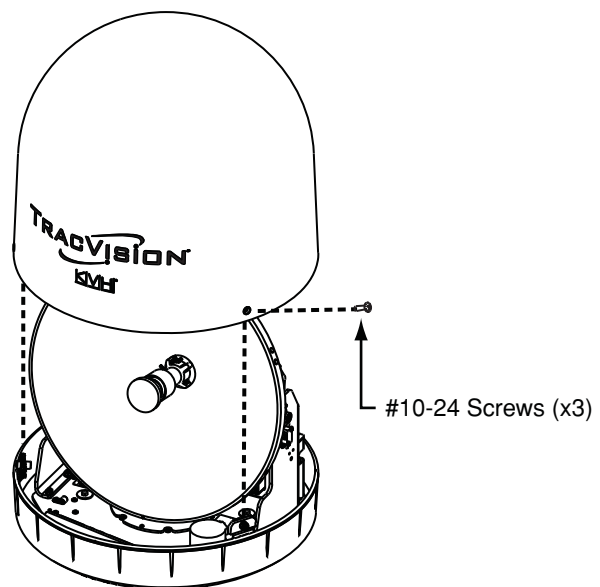

Figure 18: Installing the Radome



8 Wire the Switchplate

Follow these steps to connect the switchplate to the antenna.

- a. First dress the data and power cables from the antenna. Strip back the insulation of each wire approximately 1/4" (6 mm) and gently twist each wire to ensure a good electrical connection.
- b. Connect the data cable from the antenna to the terminal board on the back of the switchplate (see Figure 19). Be sure to match the wire colors with the terminal board label. Tighten the terminal screws to secure all wires in place.

IMPORTANT!

The diagram refers to wires by **body color/stripe color**. For example, "Brown/White" means the brown wire with the white stripe.

IMPORTANT!

Do not connect the data cable's drain wire (shield) to anything. You can simply snip it from the cable.

- c. Connect the power cable from the antenna to the switchplate's power output terminals (see Figure 20).

Figure 19: Switchplate Wiring - Antenna Data Cable

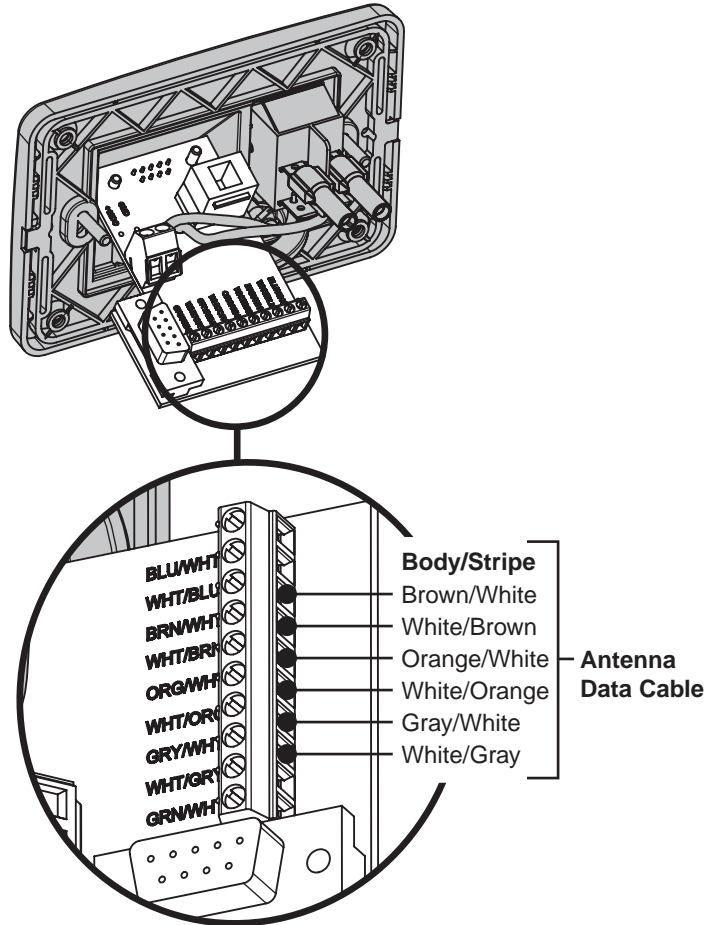
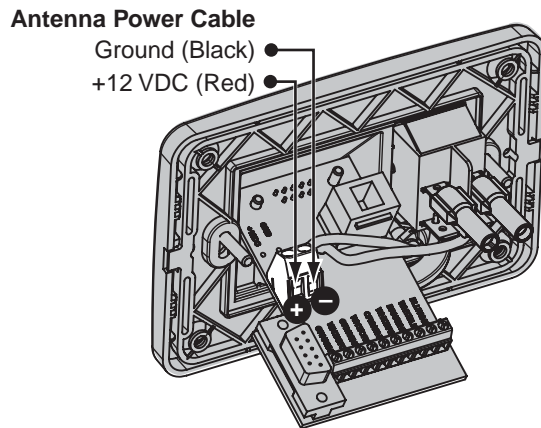

Figure 20: Switchplate Wiring - Antenna Power Cable



9 Wire the Receiver(s)

Circular and Sky Mexico

If you are installing a **circular** system, or a linear system for **Sky Mexico**, follow these steps to connect the customer's satellite TV receiver(s) to the TracVision system.

- a. Connect the RF1 cable from the antenna to the grounding block, as shown in Figure 21. Label this grounding block connector "RF1."
- b. If you are connecting multiple receivers, connect the RF2 cable from the antenna to the grounding block. Label this connector "RF2."
- c. Attach the supplied ground wire to either ground screw on the grounding block. Connect the other end of the wire to a suitable vessel AC ground.
- d. Using the two #6 screws supplied with the grounding block, mount the grounding block inside the vessel.

IMPORTANT!

If you wish to connect **three or more** receivers to the antenna, see Appendix A on page 25 (circular) or page 26 (Sky Mexico).

- e. If you are connecting two receivers to the TracVision system, decide which receiver will be the primary receiver. The primary receiver controls satellite selection.

NOTE: The secondary receiver will be able to select channels carried on the satellite that is currently selected by the primary receiver.

- f. Connect the supplied 5-ft RF cable from the "RF1" connector on the grounding block to the "Satellite In" connector on the primary receiver (see Figure 21).
- g. If you are connecting two receivers, connect an RF cable from the "RF2" connector on the grounding block to the "Satellite In" connector on the secondary receiver.
- h. Connect the receiver(s) to the customer's television(s). Follow the instructions in the receiver's manual.

Figure 21: Wiring the Receivers to the Antenna

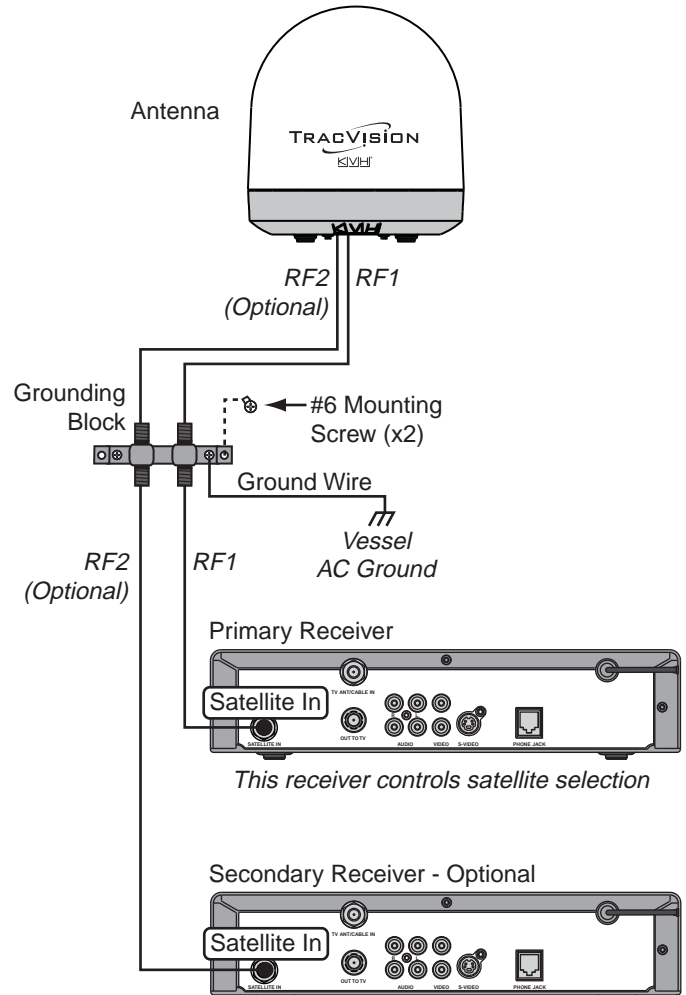

9 Wire the Receiver(s)

Linear Systems

If you are installing a **linear** system (with the exception of Sky Mexico), follow these steps to connect the customer's satellite TV receiver(s) to the TracVision system.

- a. If you are connecting multiple receivers to the TracVision system, decide which receiver will be the primary receiver. The primary receiver controls satellite selection.

NOTE: The additional receiver(s) will be able to select channels carried on the satellite that is currently selected by the primary receiver.

- b. Connect the RF1 cable from the antenna to the "Satellite In" connector on the primary receiver (see Figure 22).
- c. If you have a second receiver, connect the RF2 cable from the antenna to the "Satellite In" connector on the second receiver.
- d. If the system is equipped with a quad LNB and you have a third receiver, connect the RF3 cable from the antenna to the "Satellite In" connector on the third receiver.
- e. If the system is equipped with a quad LNB and you are connecting a fourth receiver, connect the RF4 cable from the antenna to the "Satellite In" connector on the fourth receiver.

IMPORTANT!

Be sure all receivers are grounded. If the receiver has a 2-prong power plug, run a ground wire from the receiver's chassis to a suitable ground point. If a potential exists between AC and DC grounds, connect the wire to the switchplate's DC return instead.

NOTE: If you need to connect more than four receivers to the TracVision system, install an active multiswitch that generates a 22 KHz tone (such as Spaun model SMS 5602 NF - KVH part #19-0413). Connect the multiswitch in accordance with the manufacturer's instructions.

- f. Connect the receiver(s) to the customer's television(s). Follow the instructions in the receiver's manual.

Figure 22: Wiring the Receivers to the Antenna

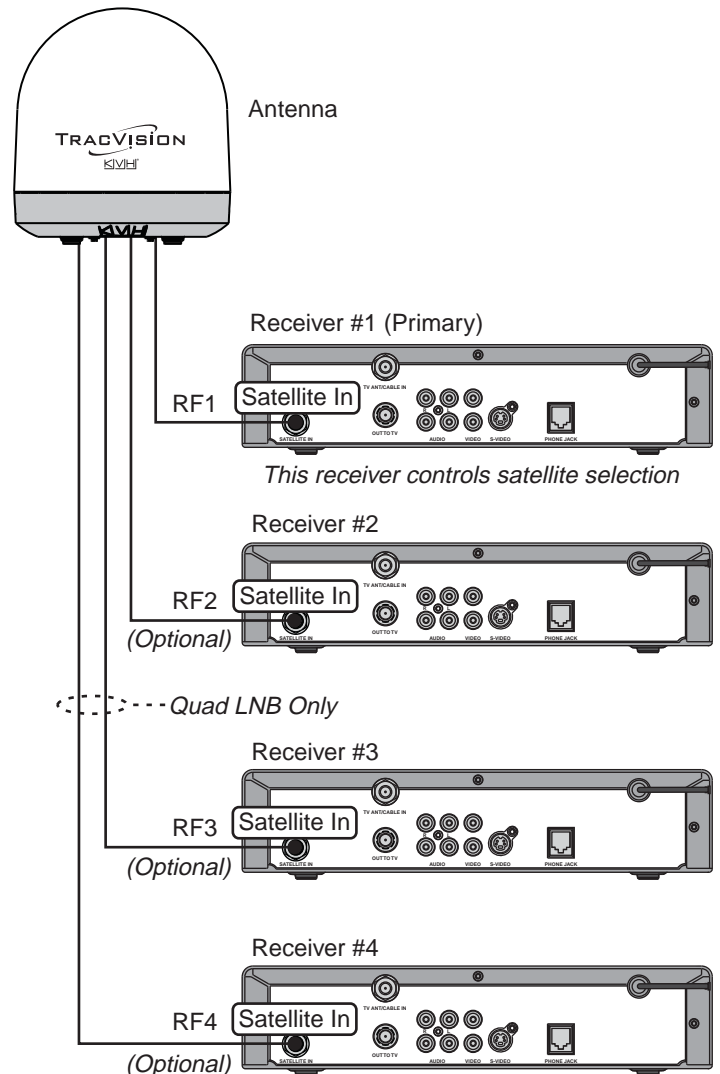

10 Connect Power

Follow these steps to connect power. The switchplate supplies power to the antenna.

- a. Before you begin, disconnect vessel power.



CAUTION

For your own safety, disconnect vessel power and make sure the circuit is dead before you connect any power wires.

- b. Connect a power cable to 12 VDC (4 amps continuous) vessel power (for cable specifications, see Figure 2 on page 3). Route the other end to the switchplate.

IMPORTANT!

Power supplied to the antenna must not fall below 12 VDC or exceed 16 VDC.

- c. Detach the two terminal connectors from the back of the switchplate and crimp them onto the power cable's wires.
- d. Connect the power cable wires to the power (+) and ground (-) input terminals on the switchplate (see Figure 23).

Figure 23: Switchplate Wiring - Vessel Power Cable

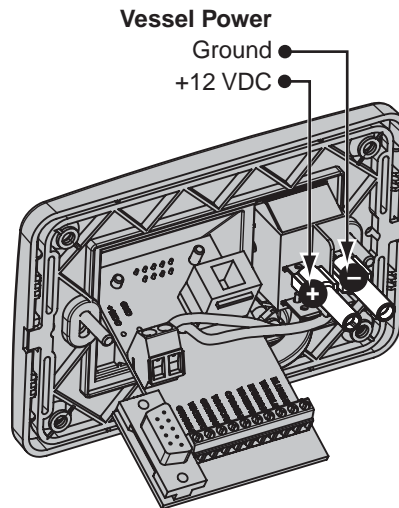

11 Mount the Switchplate

In Step 3 on page 5, you identified a suitable location for the switchplate and cut out the mounting hole in the mounting surface. Now follow these steps to mount the switchplate.

NOTE: As an alternative, the switchplate includes two additional mounting holes for installing within an electrical panel. If you chose this option, simply use two of the #6 screws to mount the switchplate to the panel.

- a. Align the four mounting holes in the switchplate with the holes in the mounting surface (see Figure 24).
- b. Mount the switchplate to the mounting surface using four #6 screws.
- c. Gently snap the front cover onto the switchplate to conceal the mounting screws.

Figure 24: Mounting the Switchplate

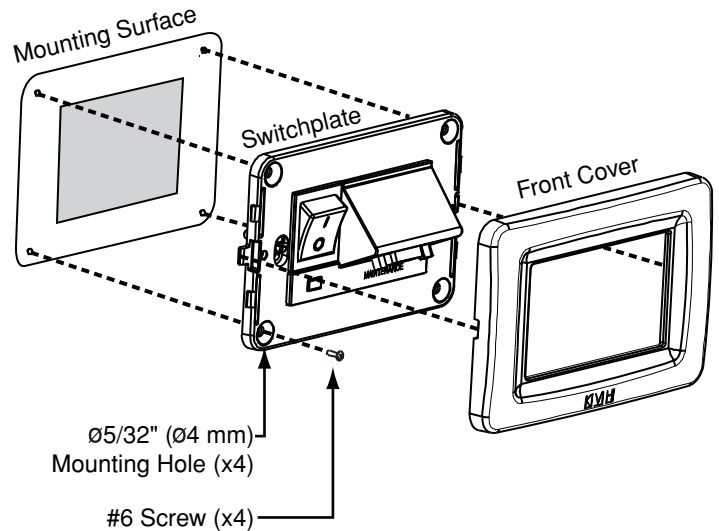

12 Connect a Laptop to the Antenna

To set up the antenna for your customer's needs, you will need to connect your laptop computer to the TracVision system then enter commands via Windows HyperTerminal (or equivalent).

TIP: If you are a KVH-authorized technician, you can use the KVH Flash Update Wizard instead of HyperTerminal. Enter commands in the wizard's "TracVision Antenna Comms" window.

- a. Using a PC serial data cable, connect your laptop to the DB9 Maintenance port on the front of the switchplate (see Figure 25). Make sure nothing is connected to the DB9 port on the back of the switchplate.

NOTE: If your computer does not have a DB9 serial COM port, you can use the USB-to-RS232 adapter manufactured by IOGear (IOGear part number GUC232A) or Belkin (Belkin part number F5U257, F5U109, or F5U409). Windows Vista users should use one of the Belkin models; 64-bit Windows Vista/7 users should use Belkin #F5U257.

- b. Open Windows HyperTerminal and establish the following settings for your COM port (see Figure 26):
 - Bits per second: 9600
 - Data bits: 8
 - Parity: None
 - Stop bits: 1
 - Flow control: None

TIP: To view characters on the screen as you type, set up HyperTerminal to echo typed characters. Select "Properties" from the File menu; select "ASCII Setup" at the Settings tab; then select "Echo typed characters locally" at the ASCII Setup window.

- c. Ensure the antenna has a clear, unobstructed view of the sky.
- d. Apply power to the satellite TV receiver(s) and the switchplate (see Figure 25). Wait one minute for system startup.
- e. Data should now be scrolling in your HyperTerminal window (see Figure 27). If no data appears, check your connections and make sure you're using the right COM port.

Figure 25: Switchplate Front Panel

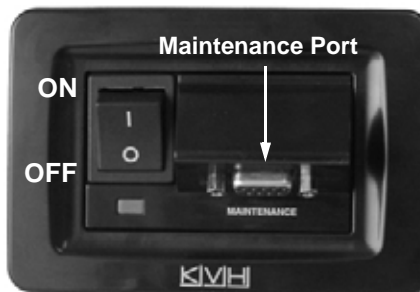
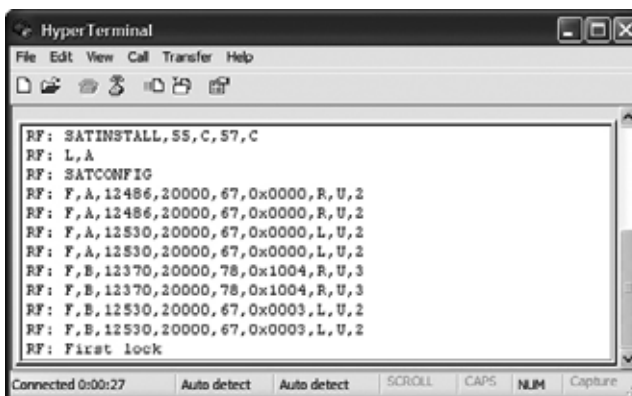

Figure 26: HyperTerminal Settings



Figure 27: Antenna Data Scrolling in Window



13 Select Satellites

Circular Systems

Follow these steps to set up a **circular** system for the desired service provider and satellites.

IMPORTANT!

The antenna is programmed at the factory for the following default satellite pair:

DSS_101 & DSS_119 (DIRECTV Dual-Sat)

If these are the customer's desired satellites, skip this step and proceed to Step 17.

IMPORTANT!

If you wish to receive DISH Network's three-satellite service, use the map in Figure 28 to help determine the appropriate DISH 1000 mode for your area. *Check with DISH Network for local channels availability.* If you want DISH 1000/61 service, skip this step and proceed to page 18. If you want DISH 1000/129 service, follow the procedure below.

Figure 28: Recommended Areas for DISH 1000 Satellites



- = DISH 129 Satellite Recommended
- = DISH 61 Satellite Recommended

Figure 29: Satellite Install Commands for Common Services

Service (Satellites)	Command
DISH 1000/129 (119, 110, 129)*	SATINSTALL,TRISAT, DISH
DISH 1000/61 (119, 110, 61)	SATINSTALL,TRISAT, DISH61
DISH 500 (119, 110)	SATINSTALL,ECHO_119, ECHO_110
Bell TV (91, 82)	SATINSTALL,EXPRESSTV, EXPRESSVU

* Optional Master Receiver Selector (KVH part #72-0412) required for automatic satellite switching; multiswitch (KVH part #72-0310) required for manual switching; see Appendix A on page 25.

Enter the following commands via Windows HyperTerminal or KVH Flash Update Wizard:

- a. Type **HALT** then press Enter.
- b. Type **DEBUGON** then press Enter.
- c. **Option 1:** Type the appropriate command in Figure 29 for the desired satellite TV service.

Option 2: If your desired setup is not listed in Figure 29, type the following command to install a custom pair of satellites from the antenna's library. Then press Enter.

SATINSTALL,SatelliteA,SatelliteB

SatelliteA = Name of 1st desired satellite
SatelliteB = Name of 2nd desired satellite
 or NONE for a single satellite

See Appendix B on page 27 for a list of all available satellites.

NOTE: If you don't find the satellite you want, you can set up user-defined satellites. Refer to the associated Application Note on the KVH Partner Portal (KVH-authorized technicians only).

- d. Type **ZAP** then press Enter. The antenna restarts. Wait one minute for system startup.

EXAMPLE

Programming DISH Network's 119, 110, and 129 satellites:

HALT
DEBUGON
SATINSTALL,TRISAT,DISH
ZAP

13 Select Satellites

Linear Systems

Follow these steps to set up a **linear** system for the desired pair of satellites.

IMPORTANT!

The antenna is programmed at the factory for the following default satellite pair:

ASTRA & HOTBIRD

If these are the customer's desired satellites, you may skip Steps a-d and proceed to Step e.

Enter the following commands via Windows HyperTerminal or KVH Flash Update Wizard:

- a. Type **HALT** then press Enter.
- b. Type **DEBUGON** then press Enter.
- c. **Option 1:** Type the appropriate command in Figure 30 for the desired Tri-Sat mode.

Option 2: If your desired setup is not listed in Figure 30, type the following command then press Enter. Italics indicate a variable.

SATINSTALL, *SatelliteA*, *SatelliteB*

SatelliteA = Name of 1st desired satellite
SatelliteB = Name of 2nd desired satellite or NONE for a single satellite

See Appendix B on page 27 for a list of all available satellites. Be sure to enter the satellite names as they appear in the library.

NOTE: *If you don't find the satellite you want, you can set up user-defined satellites. Refer to the associated Application Note on the KVH Partner Portal (KVH-authorized technicians only).*

- d. Type **ZAP** then press Enter. The antenna restarts. Wait one minute for system startup.
- e. Set up the receiver(s) for the same satellites, and in the same order, that you set them up in the antenna (see Figure 31).

Figure 30: Satellite Install Commands for Tri-Sat Modes

Satellites	Command
A = Hotbird B = Astra 1 C = Astra 2S	SATINSTALL, TRISAT, EUR
A = Hotbird WB B = Astra 1 C = Astra 2S	SATINSTALL, TRISAT, EWB
A = Hotbird WB B = Sirius C = Thor	SATINSTALL, TRISAT, SCN

EXAMPLE

Programming the PAS 9 satellite for Sky Mexico service:

HALT
DEBUGON
SATINSTALL, PAS_9, NONE
ZAP

Figure 31: Antenna and Receiver Satellite Synchronization

Antenna	Receiver	DiSEqC
Sat. A	Alternative 1 or A	DiSEqC 1
Sat. B	Alternative 2 or B	DiSEqC 2
Sat. C*	Alternative 3 or C	DiSEqC 3

* Sat. C only applies to Tri-Sat modes.

14 Enter Your Latitude & Longitude

Follow these steps to enter your vessel's latitude and longitude into the antenna. If you are installing a **linear** system, this step is required. If you are installing a **circular** system, this step is highly recommended, especially for DISH Network and Bell TV configurations.

NOTE: The antenna will use your position data to speed up satellite acquisition. If the antenna knows where you are, it knows where it should start looking for the satellite (see Figure 32). In addition, for a linear system, the antenna will use your position information to calculate the correct LNB skew angle.

TIP: You can determine your approximate latitude and longitude in Europe or North America from the position grids provided in Appendix C on page 28.

To enter your position information into the antenna, enter the following commands via Windows HyperTerminal or KVH Flash Update Wizard:

- Type **HALT** then press Enter.
- Type **DEBUGON** then press Enter.
- Type the following command then press Enter. Italics indicate a variable.

GPS,XX,A,YYY,B

XX = Latitude (0-90)

A = **S** (South) or **N** (North)

YYY = Longitude (0-180)

B = **E** (East) or **W** (West)

Do not enter decimals. Simply round your latitude and longitude to the nearest whole numbers.

- Type **ZAP** then press Enter. The antenna restarts. Wait one minute for system startup.

Figure 32: Direction to Satellite Depends on Your Location

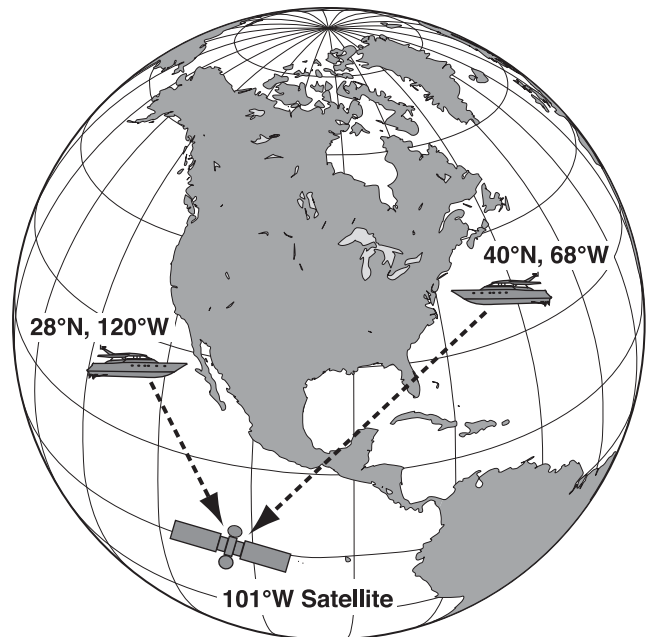

EXAMPLE

Entering a vessel position of 57°N, 22°E:

```
HALT  
DEBUGON  
GPS,57,N,22,E  
ZAP
```

15 Run Check Switch Tests

If you set up the system for **DISH Network** or **Bell TV** (formerly ExpressVu), follow these steps to run the receiver's Check Switch test as required.

Primary Receiver - 2 Check Switch Tests

Follow these steps to run two Check Switch tests on the primary receiver, which is connected to the antenna's "RF1" cable. This receiver will control satellite selection.

IMPORTANT!

If you purchased a **preconfigured** DISH receiver from KVH, you only need to run **one** Check Switch test to set up the system.

- a. Make sure the vessel is docked in calm water in a blockage-free area. Ensure the antenna has an unobstructed view of the sky.
- b. Apply power to the TV and receiver. (If the antenna is turned off, turn it back on and wait a few minutes for startup.)
- c. Using the receiver's remote, go to the "Point Dish/Signal Strength" screen (press MENU, 6, 1, 1 on most models).
- d. Choose **Check Switch**, then press SELECT.
- e. Choose **Check** or **Test**, then press SELECT.
- f. Wait at least 15 minutes before proceeding to allow the antenna to find all of the satellites. Disregard any messages on the TV; they do not correctly indicate when the antenna is ready for the next Check Switch test.
- g. Once you have waited the proper amount of time, choose **Retest** or **Test**, then press SELECT to run a second Check Switch test.
- h. Refer to the tables in Figure 33 and verify the values displayed on your TV match those required for your selected service.

If your values match, exit the menu. The receiver will download the program guide.

If your values do not match, turn off the antenna, then turn it back on and repeat Steps c-h.

DISH Network or Bell TV Only

Figure 33: Expected Check Switch Results Displayed on TV

DISH 1000/129 Results

Port	1	2	3
Satellite	119	110	129
Trans	OK	OK	OK
Status	Reception Verified		
Switch	SW64		

DISH 1000/61 Results

Port	1	2	3
Satellite	119	110	61
Trans	OK	OK	OK
Status	Reception Verified		
Switch	SW64		

DISH 500 Results

Input	1	1	2	2
Satellite	119	119	110	110
Polarity	Odd	Even	Odd	Even
Status	Reception Verified			
Switch	SW42			

Bell TV Results*

Input	1	1	2	2
Satellite	91	91	82	82
Polarity	Odd	Even	Odd	Even
Status	Reception Verified			
Switch	SW21			

* If you installed just one Bell TV satellite, the TV will show an error message instead. This is normal.

Additional Receiver(s) - 1 Check Switch Test

If you connected multiple receivers, follow these steps to run a Check Switch test on each additional receiver (one at a time), **unless it is a preconfigured DISH receiver**. *When you are done, reconnect the receivers as before.*

- a. Temporarily disconnect the primary receiver from the antenna's "RF1" cable.
- b. Connect the additional receiver to the antenna's "RF1" cable.
- c. Perform Steps a-e on page 19 to run a single Check Switch test on the receiver.
- d. Wait 15 minutes, then verify the values on the TV match the values shown in Figure 33 on page 19. If your values do not match, try running another Check Switch test.

16 Set the LNB Skew Angle

Linear Systems

Follow these steps to set the antenna's **linear** LNB to the correct skew angle for your selected satellite and vessel position.

- a. Using HyperTerminal or KVH Flash Update Wizard, type **SKEWANGLE** then press Enter. Note the reported skew angle.

TIP: If multiple satellites are installed, you might wish to set an **average skew** instead. To find the average skew, select the second satellite then repeat Step a to get the skew angle (repeat for the third satellite if Tri-Sat). Add the skew angle numbers and divide by two (or three if Tri-Sat) to get the average.

- b. Turn off and unplug the receiver(s) and disconnect antenna power at the switchplate.

	CAUTION
<p>Disconnect power from the antenna and the receivers before you adjust the LNB. The antenna's moving parts can cause injury.</p>	

- c. Remove the antenna's radome, if you reinstalled it earlier in Step 7.
- d. Locate the LNB on the back of the antenna's reflector (see Figure 34).
- e. Using a 2 mm allen hex key, loosen the two M4 socket set screws securing the LNB to the reflector (see Figure 35).
- f. Adjust the LNB clockwise or counter-clockwise until the skew arrow on the LNB points to the skew angle that you noted in Step a (see Figure 36). If the skew angle is greater than +15°, subtract 180 to get the equivalent negative skew angle and set the LNB to that angle instead (e.g., +35 = -145).

<p>IMPORTANT!</p> <p>Be sure to keep the LNB fully inserted into the choke feed to ensure optimum performance.</p>

- g. Tighten the two M4 socket set screws to secure the LNB in place. Apply 9 in-lbs (1 Nm) of torque, if possible.
- h. Reinstall the radome (as explained in Step 7d on page 9).

Figure 34: LNB Location on Back of Antenna's Reflector

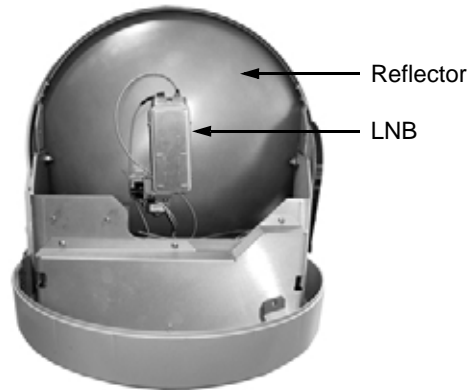

Figure 35: Set Screws Securing the LNB to the Reflector

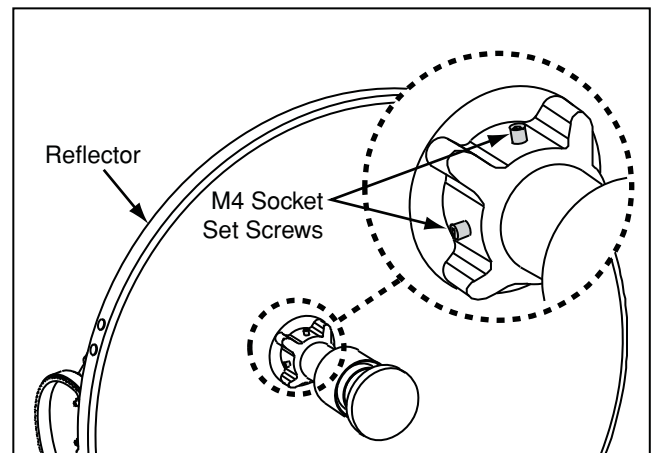
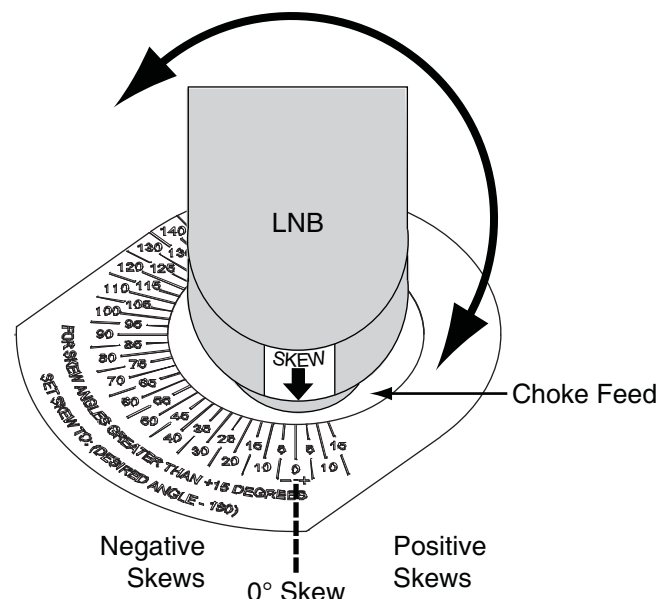



Figure 36: LNB Skew Angle Adjustment



17 Educate the Customer

Before you leave the vessel, test the system to verify the antenna works properly. Then give the Customer Welcome Kit to the customer and be sure the customer understands the following:

- The receiver(s) must be activated before it can decode satellite TV signals. Refer to Figure 37 for activation details for North America.
- Keep the radome installed on the antenna at all times. The radome protects the antenna's moving parts from wind, rain, and debris.

	WARNING
It is dangerous to watch TV while piloting a vessel. While under way, the system is intended for passenger entertainment only.	

- The antenna must have a clear view of the sky to receive satellite TV. Common causes of blockage include trees, buildings, bridges, and onboard equipment (see Figure 38). Heavy rain or snow may also temporarily interrupt reception.
- Clean the antenna regularly. Dirt buildup on the radome can affect reception.
- **DISH 1000 modes only:** You might need to change the operating mode when traveling between regions (see "Select Satellites" on page 16).
- **Linear only:** You might need to adjust the skew angle of your antenna's LNB when you travel to other geographic locations, (see "Set the LNB Skew Angle" on page 21).
- The vessel must be located within the selected satellite's coverage area to receive its satellite TV signals. To view satellite coverage maps, visit www.kvh.com/footprint.
- Please register the system with KVH. The registration process is quick, easy, online, and ensures the best possible service from KVH. Visit www.kvh.com/register or refer to the Product Registration Form for details.
- Refer to the *User's Guide* for operation and troubleshooting information.

Figure 37: North American Receiver Activation Information

Service:	Call to Activate:
DIRECTV	1-866-551-8004 (24 hours, 7 days a week)
DISH Network	1-866-399-8509 (Mon.-Fri., 8:30am - 5pm ET)
Bell TV	1-888-759-3474 (SKY-DISH) (24 hours, 7 days a week)

Figure 38: Example of Satellite Blockage

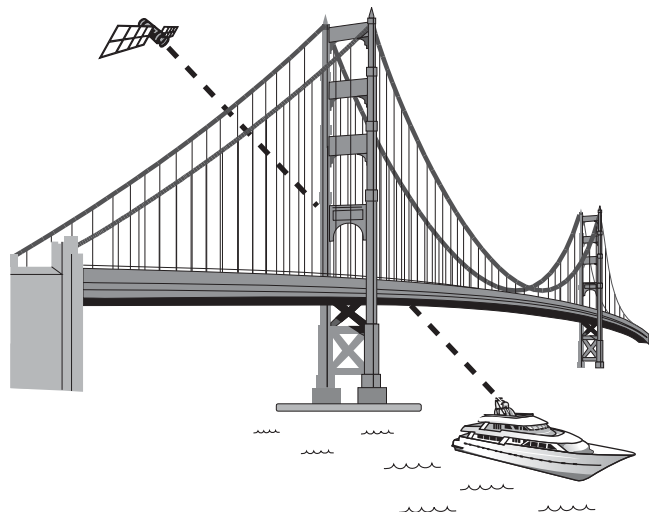

Appendices

This section provides supplemental instructions for wiring multiple receivers. It also provides a list of available satellites, system wiring diagrams, and a mounting template for the belowdecks equipment.

Contents

A. Wiring 3+ Receivers	25
B. Satellite Library.....	27
C. Position Grids.....	28
D. Basic System Wiring Diagram	29
E. Switchplate Mounting Template.....	31

A Wiring 3+ Receivers

Circular Systems

If you need to connect three or more receivers, or you set up the system for DISH Network's 129 satellite (one or more receivers), install an active (powered) multiswitch or Master Receiver Selector between the grounding block and the receivers, as shown in Figure 39.

NOTE: If you need to connect more than four receivers, please contact KVH Technical Support.

Active Multiswitch

The optional Eagle Aspen multiswitch with AC/DC power supply (KVH part #72-0310) allows you to connect up to four receivers to the TracVision system. However, since a multiswitch interrupts satellite switching communications between the receiver and the antenna, you will need to manually switch between your selected satellites.

With the TV/SAT Switch (KVH part #01-0245) installed, you can manually switch between a pair of satellites at the press of a single button. Alternatively, you can manually switch between two or three satellites using a PC connected to the switchplate's Maintenance port. See the *User's Guide* for details.

IMPORTANT!

The TV/SAT Switch only supports dual-satellite configurations, so it cannot be used with three-satellite DISH 1000 modes. If you need to connect three or more receivers in a DISH 1000 mode, the best option is the Master Receiver Selector (see below).

Master Receiver Selector

The optional KVH Master Receiver Selector (KVH part #72-0412) is an enhanced multiswitch that provides the following capabilities:

- Automatic satellite switching in any operating mode, including DISH 1000/129.
- Support for multiple receivers.
- Capability for the user to select, at any time, which receiver controls satellite selection. Simply turn the knob!

Figure 39: Wiring Up to 4 Receivers

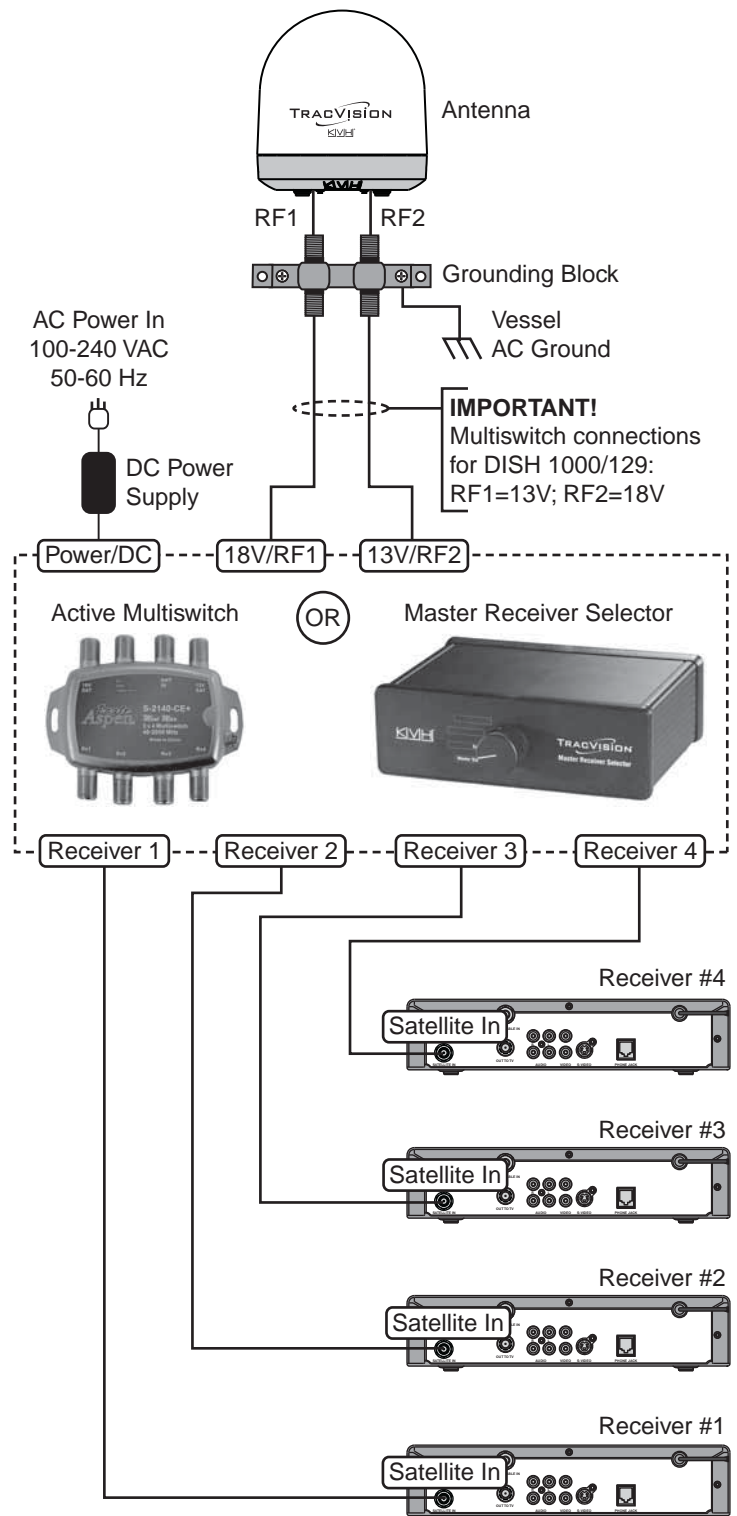

A Wiring 3+ Receivers

Sky Mexico Systems

To connect three or more receivers to a system configured for **Sky Mexico**, follow these steps to install a Spaun model SMS 5602 NF multiswitch (KVH part #19-0413) between the grounding block and the receivers, as shown in Figure 40.

1. Connect an RF cable from the “RF1” connector on the grounding block to the “H/High” (Horizontal High) connector on the multiswitch.
2. Connect an RF cable from the “RF2” connector on the grounding block to the “V/High” (Vertical High) connector on the multiswitch.
3. Set the multiswitch’s LNB knob to “22 KHz.” *At this setting, the multiswitch will provide a constant 22 KHz tone to the antenna’s LNB.*
4. Connect the receivers to the individual outputs of the multiswitch.
5. Connect the receivers to the customer’s TVs.

Figure 40: Multiswitch Wiring - Sky Mexico

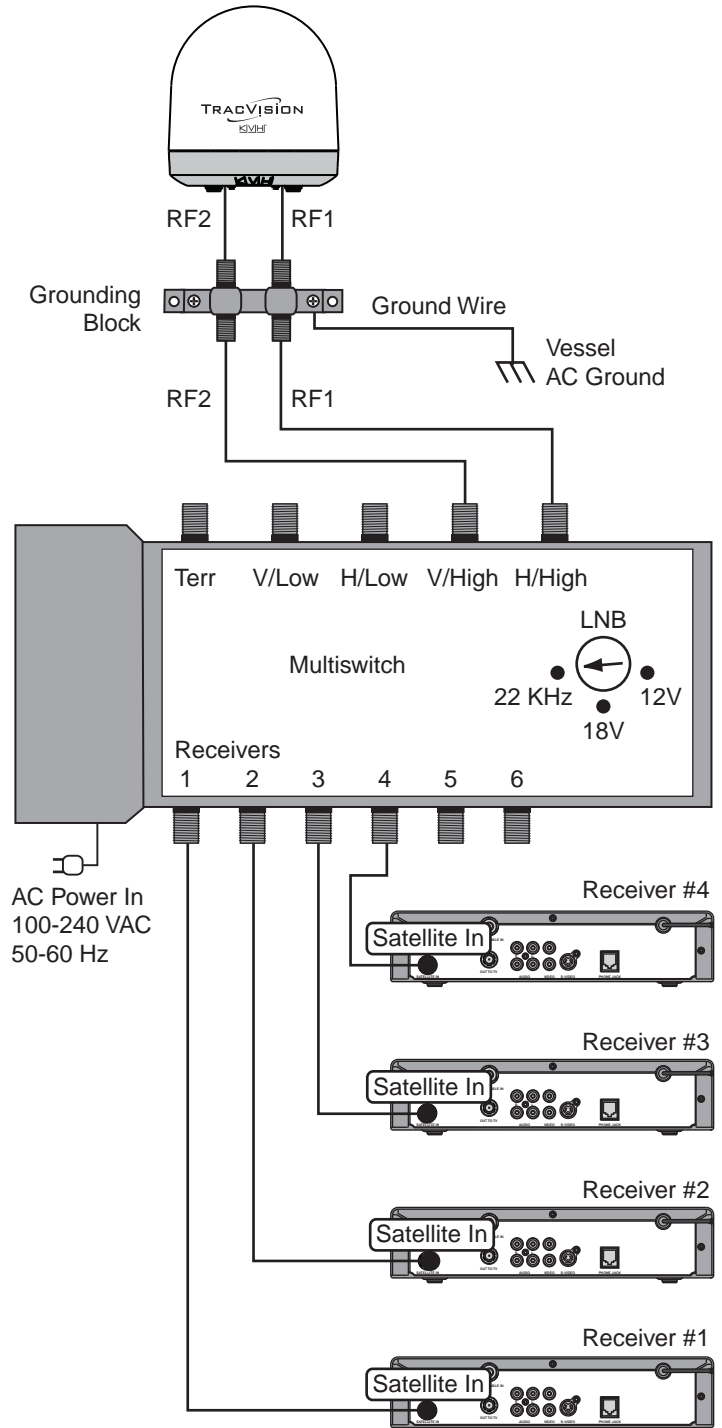

B Satellite Library

The TracVision antenna can track a variety of DVB-compatible and DSS (DIRECTV) satellites. Most popular satellites are programmed in the antenna's library (see the tables below).

North America

Circular LNB Required

Satellite, Longitude	Name in Library
DIRECTV, 72°W	DSS_72
DIRECTV, 101°W	DSS_101
DIRECTV, 110°W*	DSS_110
DIRECTV, 119°W	DSS_119
EchoStar, 61°W	ECHO_61
EchoStar, 110°W	ECHO_110
EchoStar, 119°W	ECHO_119
EchoStar/Ciel 2, 129°W	ECHO_129
Bell TV, 82°W	EXPRESSVU
Bell TV, 91°W	EXPRESSTV

* DIRECTV HD not supported.

Asia

Circular LNB Required

Satellite, Longitude	Name in Library
Asiasat 4, 122.2°E	ASIASAT
Sinosat 1, 110.5°E*	SINOSAT

* Special LNB required. Call KVH at 1-401-847-3327.

Latin America

Galaxy Circular LNB Required

Satellite, Longitude	Name in Library
Galaxy 3C, 95°W	GALAXY3CN

Europe

Linear LNB Required

Satellite, Longitude	Name in Library
Astra 1, 19.2°E	ASTRA1
Astra 2N, 28.2°E	ASTRA2N
Astra 2S, 28.2°E	ASTRA2S
Hispasat, 30.0°W	HISPASAT
Hotbird, 13.0°E	HOTBIRD
Hotbird WB, 13.0°E	HOTBIRDWB
Astra (Sirius), 5.0°E	SIRIUS
Thor, 0.8°W	THOR
Arabsat/Badr 4, 26°E	ARABSAT
Nilesat, 7°W	NILESAT
Turksat 1C, 42°E	TURKSAT1C
Eutelsat W3A, 7°E	EUTEL_W3A

Mexico

Linear LNB Required

Satellite, Longitude	Name in Library
PAS 9/Intelsat 9, 58°W	PAS_9

Australia & New Zealand

Linear LNB Required

Satellite, Longitude	Name in Library
Optus D1, 160°E	OPTUS_D1
Optus C1, 156°E	OPTUS_C1

C Position Grids

If the vessel is located in Europe or North America, you may use the appropriate grid and table below to determine your approximate latitude and longitude.

Europe

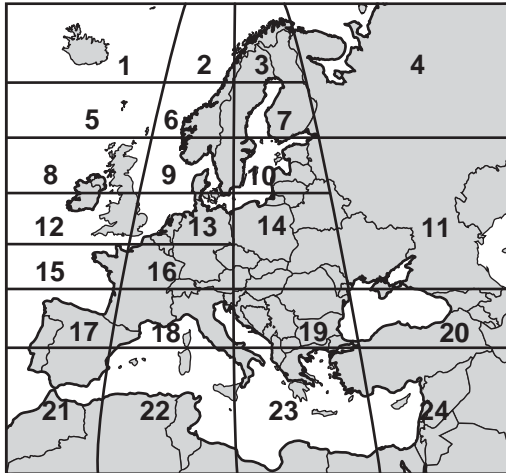

Grid #	Latitude	Longitude
1	67° N	7° W
2	67° N	7° E
3	67° N	22° E
4	65° N	45° E
5	63° N	7° W
6	63° N	7° E
7	63° N	22° E
8	57° N	7° W
9	57° N	7° E
10	57° N	22° E
11	55° N	40° E
12	53° N	7° W
13	53° N	7° E
14	50° N	22° E
15	47° N	7° W
16	47° N	7° E
17	43° N	7° W
18	43° N	7° E
19	43° N	22° E
20	43° N	37° E
21	36° N	7° W
22	36° N	7° E
23	36° N	22° E
24	36° N	37° E

North America

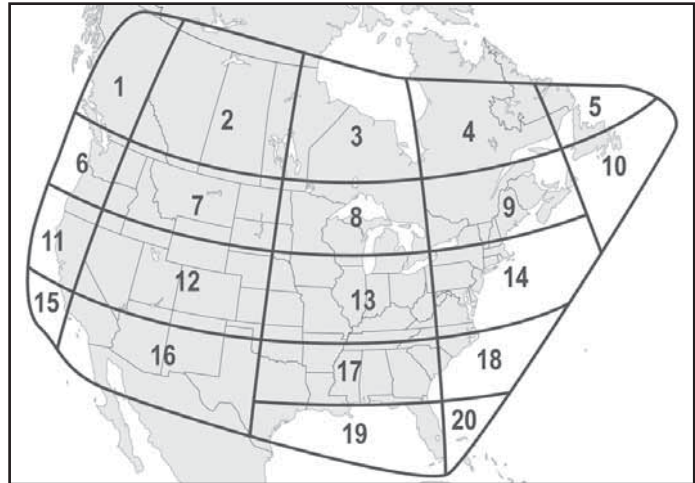

Grid #	Latitude	Longitude
1	55° N	125° W
2	55° N	110° W
3	55° N	90° W
4	55° N	70° W
5	55° N	55° W
6	45° N	125° W
7	45° N	110° W
8	45° N	90° W
9	45° N	70° W
10	45° N	50° W
11	40° N	125° W
12	40° N	110° W
13	40° N	90° W
14	40° N	70° W
15	32° N	125° W
16	32° N	110° W
17	32° N	90° W
18	32° N	75° W
19	27° N	83° W
20	27° N	78° W

D Basic System Wiring Diagram

Circular and Sky Mexico

This wiring diagram shows a basic circular or Sky Mexico system configuration.

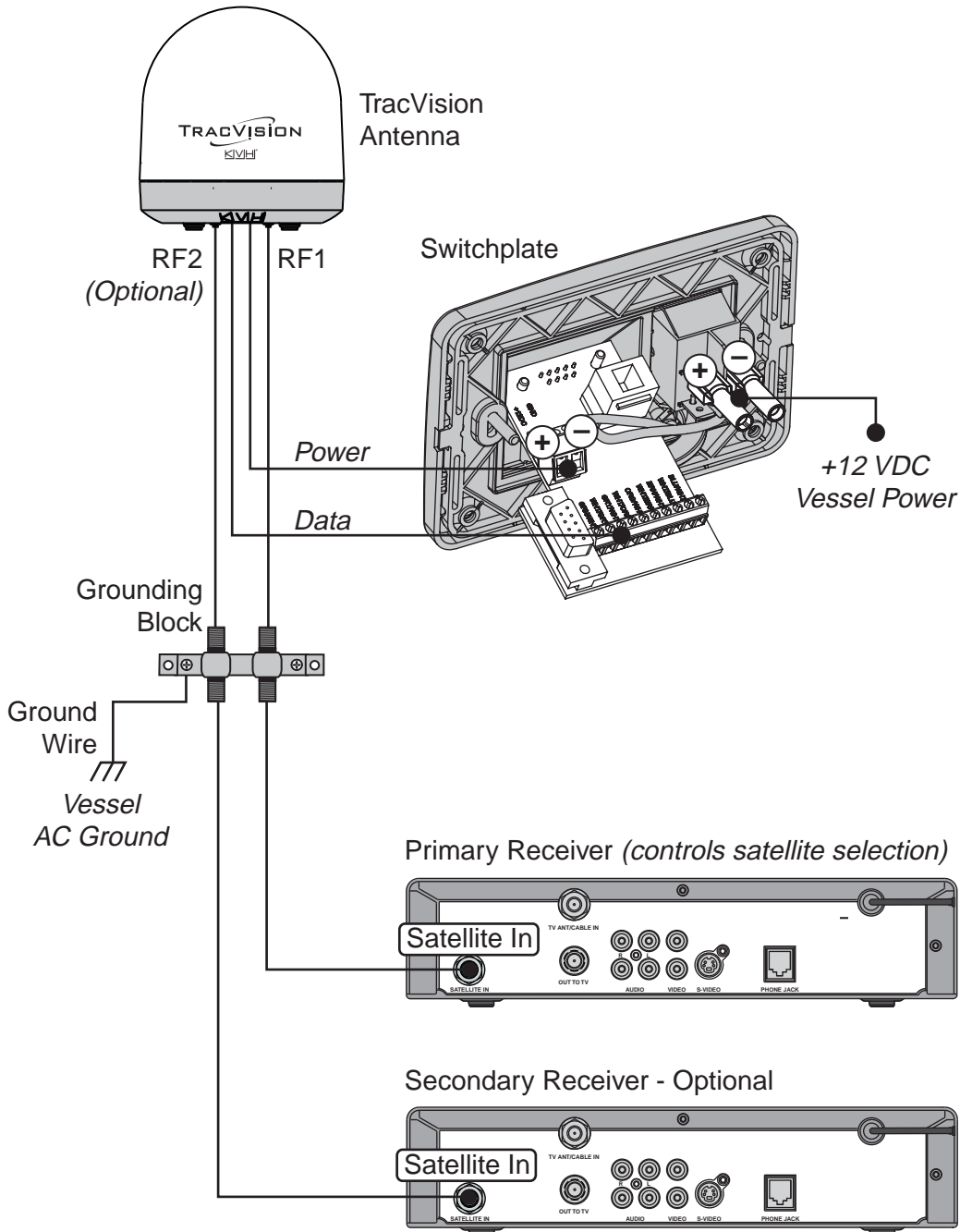

D Basic System Wiring Diagram

Linear Systems

This wiring diagram shows a basic linear system configuration.

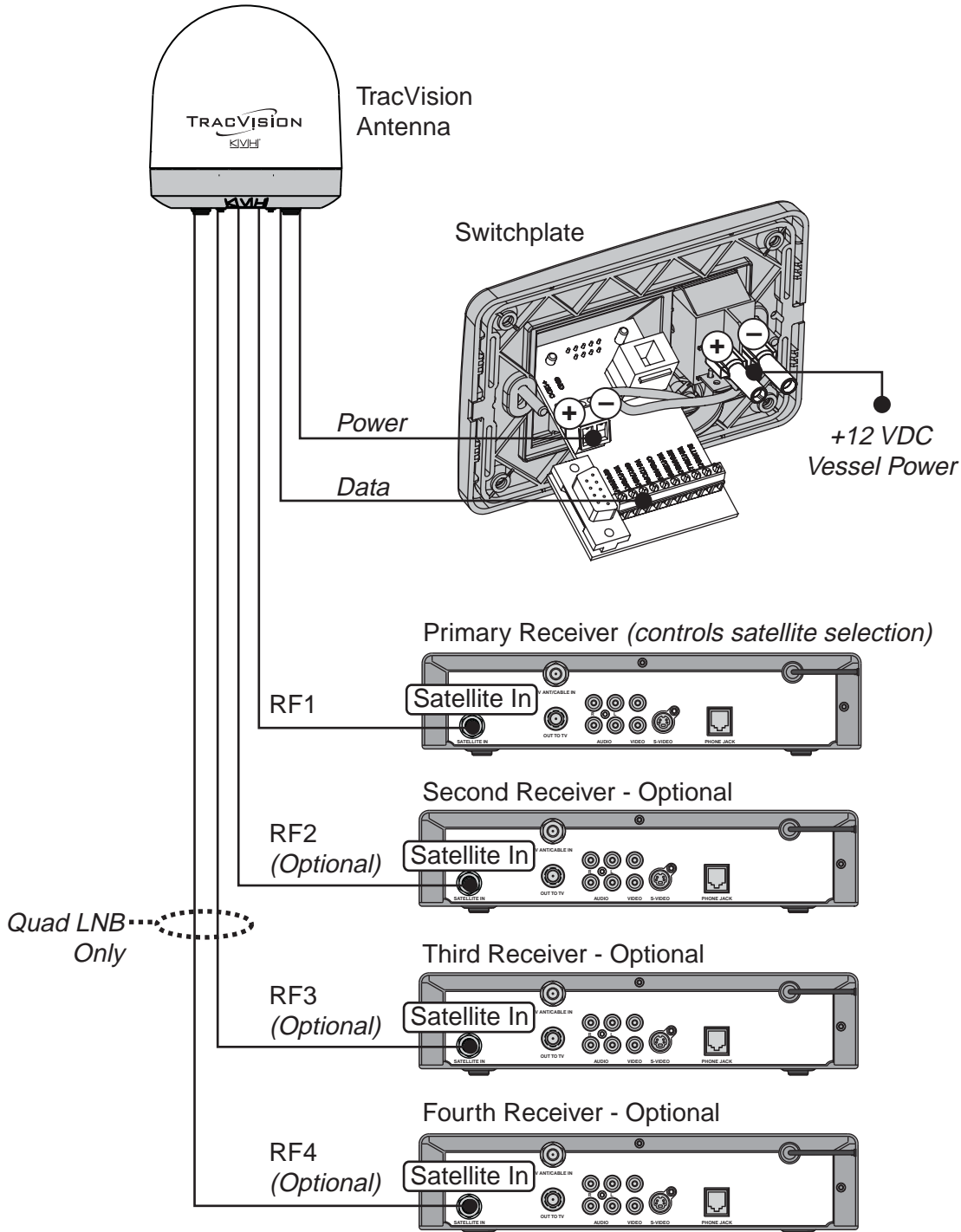

E

Switchplate Mounting Template

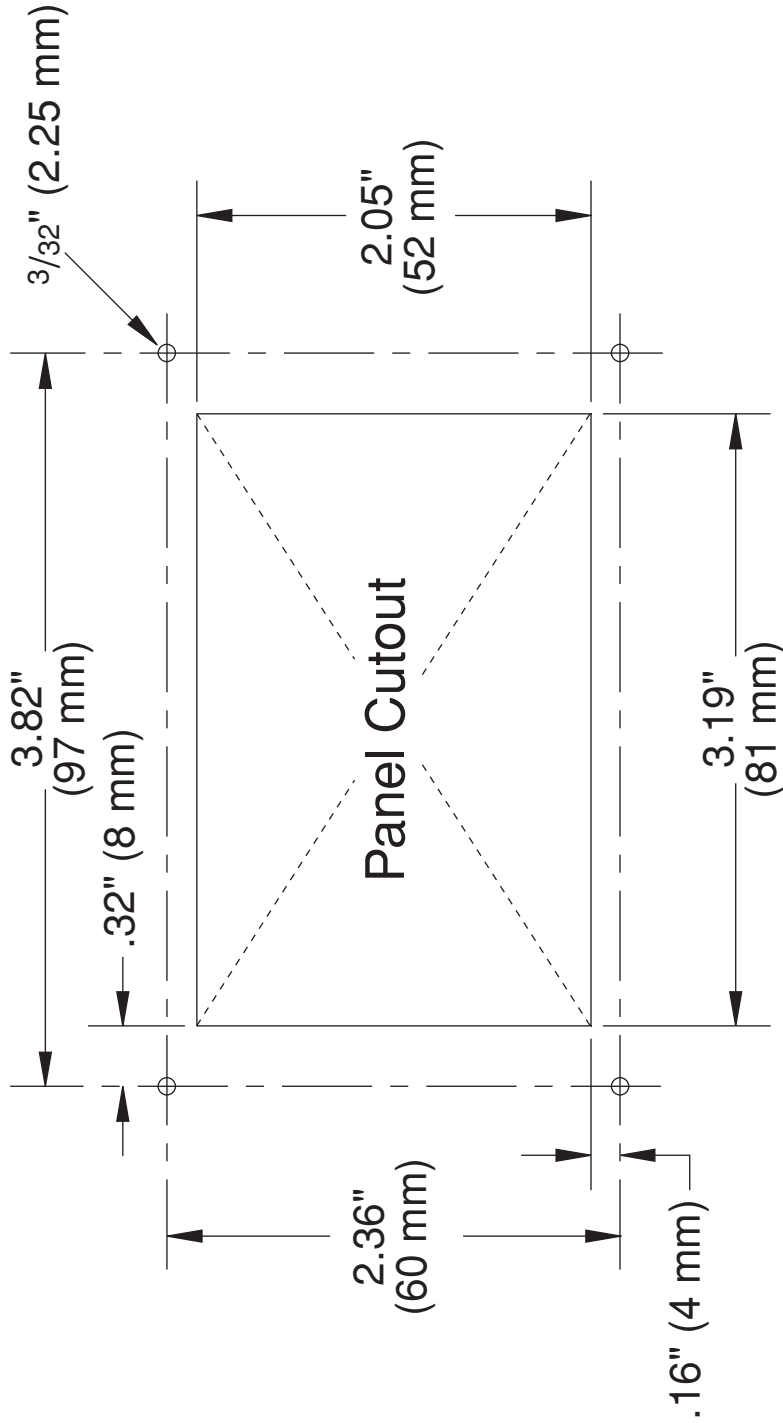



www.kvh.com

KVH Industries, Inc.
Middletown, RI U.S.A.
Tel: +1 401 847 3327
Fax: +1 401 849 0045
E-mail: info@kvh.com

KVH Europe A/S
Kokkedal, Denmark
Tel: +45 45 160 180
Fax: +45 45 160 181
E-mail: info@kvh.dk

KVH Norway AS
Horten, Norway
Tel: +47 33 03 05 30
Fax: +47 33 03 05 31
E-mail: commboxsales@kvh.com

KVH Singapore
Singapore
Tel: +65 6829 2343
Fax: +65 6829 2121
E-mail: infokvhsingapore@kvh.com