

TracVision® R5/R4 Installation Guide

These instructions explain how to install the TracVision R5/R4 satellite TV antenna system on an RV or motor coach. Complete instructions on how to use the system are provided in the *User's Guide* and your selected receiver's user manual.

Step		See Page
1.	Inspect Parts and Get Tools	2
2.	Plan the Installation	3
3.	Remove the Shipping Restraints	4
4a.	Mount the Antenna (Standard)	5
4b.	Mount the Antenna (Alternate)	6
5.	Cut the Switchplate Mounting Hole	7
6.	Wire the Antenna	8
7.	Seal the Cable Access Hole	9
8.	Wire the Receiver(s)	10
9.	Wire the Switchplate	11
10.	Mount the Switchplate	12
11a.	Install Satellites (DISH 311 Receivers Only)	13
11b.	Install Satellites	14
12.	Find the Skew Angle (Europe Only)	16
13.	Set the Skew Angle (Europe Only)	17
14.	Test the System	18
15.	Educate the Customer	19

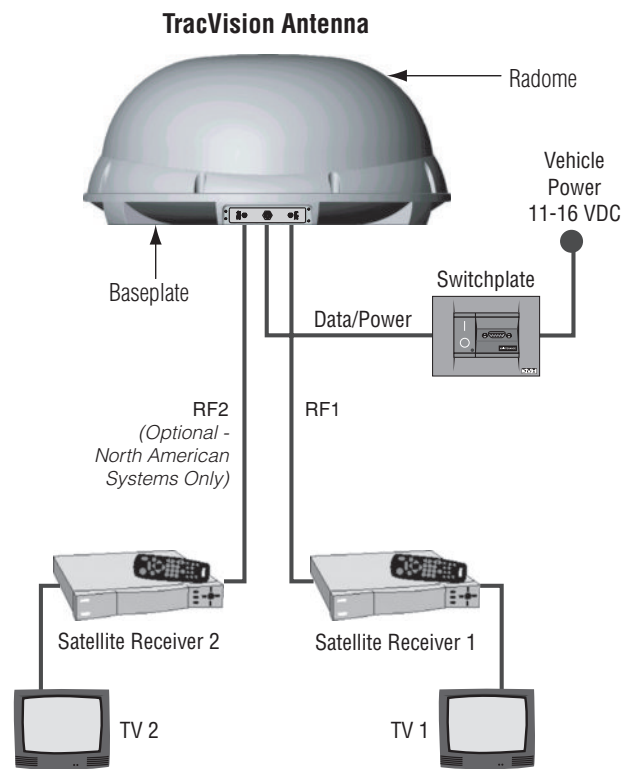

Technical Support

If you need technical assistance, please contact KVH Technical Support:

North America, South America, Australia:

Phone: +1 401 847-3327

Email: techs@kvh.com

Europe, Middle East, Asia:

Phone: +45 45 160 180

Email: support@kvh.dk



PLEASE READ!

Important Addendum to Your Product Manual

This addendum applies to the following TracVision antenna models: R4, R5, R4SL, R5SL, and C3.

New Switchplate Design

The switchplate provided with your system differs slightly from the version shown in your manual. Its input power connections are simple power terminals rather than a recessed terminal block.



To connect vehicle/vessel power to this new switchplate, follow the steps below.

- a. Disconnect vehicle/vessel power. Test the circuit to ensure that no power is present.
- b. Crimp the supplied terminal connectors onto the vehicle/vessel power wires (the DC power wires if using an AC/DC power supply).
- c. Carefully push the connectors onto the switchplate's input power terminals as shown in the illustration below.

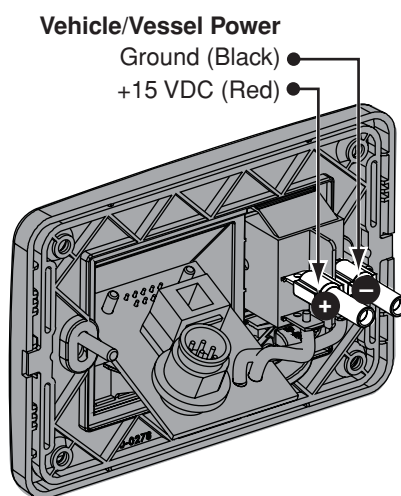

Note: Strain-relieve the wires to ensure a reliable connection.

All other installation and operation steps remain the same as described in the manual.



PLEASE READ!

Important Addendum to Your Product Manual

This addendum applies to the following TracVision antenna models: R4, R5, R4SL, R5SL, and C3.

Power Supply and Grounding Kit

A 15-volt, 4-amp power supply and grounding kit are now included with your TracVision system. Be sure to install these components as explained in this addendum.

The power supply will ensure a stable power input to the TracVision antenna. (Low power, fluctuating power, and RF noise can affect the antenna's performance.) The grounding block will provide a single ground point for the system and provide lightning protection.

Power Supply



Grounding Block



Installing the Power Supply

Follow the steps below to install the supplied power supply.

- a. Disconnect vehicle/vessel power. Test the circuit to ensure that no power is present.
- b. Connect the power supply's power and ground wires to the switchplate's input power terminals, as shown in the diagram on the following page.
- c. Plug the power supply into vehicle/vessel AC power.

Installing the Grounding Block

Follow the steps below to install the grounding block.

- a. Connect the grounding block in-line with the antenna's RF cable(s), between the antenna and the receiver(s), as shown in the diagram below.
- b. Mount the grounding block to a structure inside the vehicle/vessel.
- c. Attach the supplied ground wire to either ground screw on the grounding block. Connect the other end of the wire to vehicle/vessel AC ground.

All other installation steps remain the same as described in the manual.

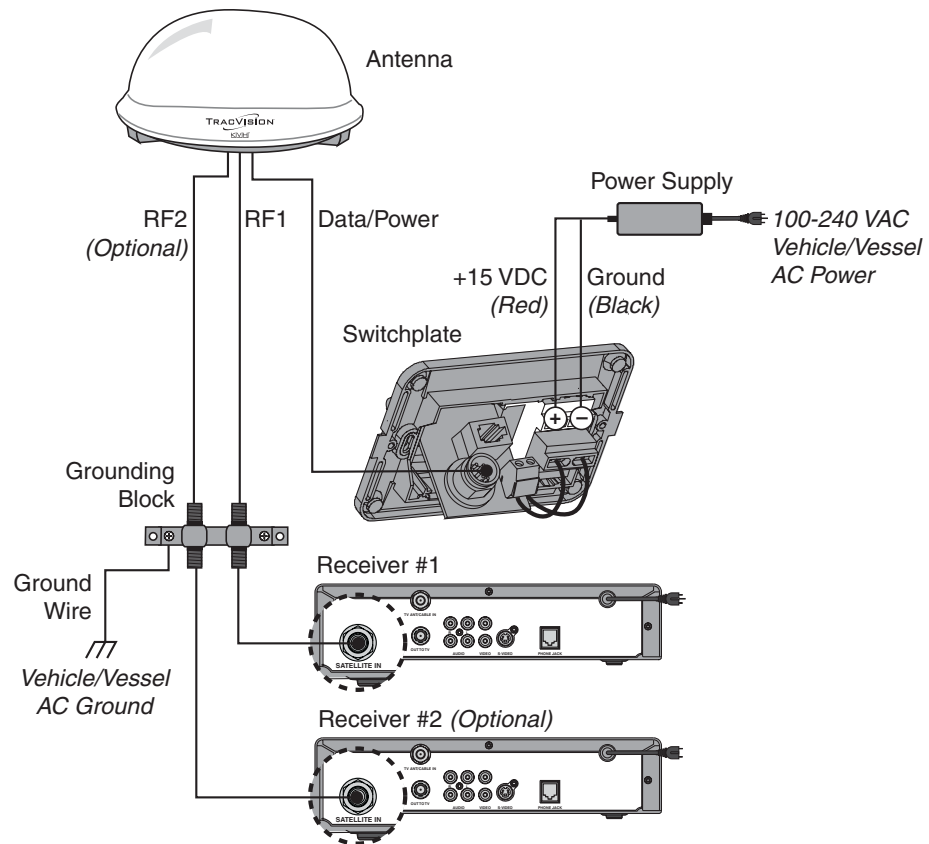

1 Inspect Parts and Get Tools



Always lift the antenna by the baseplate, never by the radome!



The Flash Update Wizard is available to KVH-authorized dealers through the KVH Partner Portal.

1. Unpack the box and ensure it contains everything shown on the supplied Contents List. *Cables for the R5/R4 system are stored beneath the antenna unit during shipping.*
2. Carefully examine all of the supplied parts to ensure nothing was damaged in shipment.
3. Gather all of the tools and materials listed below. You will need these items to complete the installation.
 - Electric drill
 - 3/16" (5 mm), 5/32" (4 mm), and 3/32" (2.5 mm) drill bits
 - 3/4" (19 mm) hole saw and auger bit
 - 9/64" allen wrench (*European systems only*)
 - Phillips and Flat head screwdrivers
 - RG-6 or RG-11 (75 ohms) RF cable (*if installing two RF cables*)
 - Silicone sealant, RTV, or equivalent
 - 7/16" open-end wrench
 - Construction adhesive suitable for the roof
 - Fasteners suitable for mounting the antenna to the roof
 - Augat IT1000 crimp/strip tool (*KVH Part # 19-0242*)
 - PC with the latest version of the KVH Flash Update Wizard installed

2 Plan the Installation

Before you begin, consider the following installation guidelines:

- Minimize blockage. The antenna needs a clear view of the sky to receive satellite TV. Using the table as a guide, mount the antenna a suitable distance away from obstructions on the roof, such as air conditioners.

Height of Obstruction (A)	Minimum Distance from Antenna (B)
8"	6"
10"	12"
12"	17"
14"	23"
16"	28"

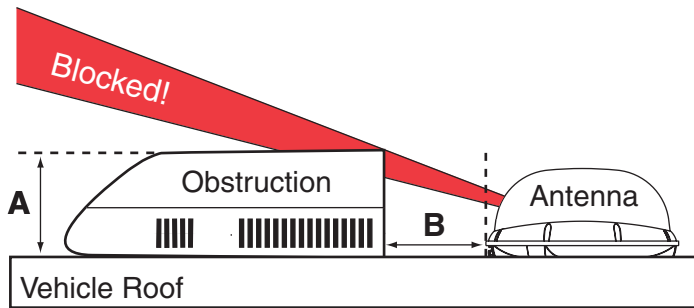

Antenna Blockage

- Find a location on a flat part of the roof on the centerline of the vehicle.
- The antenna must be mounted on a horizontal surface. When placed flat on the mounting surface, the mounting plates should be less than 7/16" above the mounting surface.



Any gap larger than 7/16" will warp the baseplate and seriously damage the antenna.

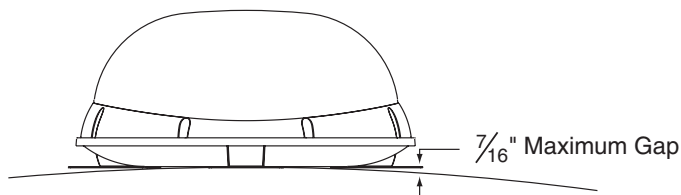

Maximum Mounting Surface Slope

- When choosing a location for the switchplate, find a dry, flat location that will be easily accessible to the user. Take into account cable lengths between components, as well as accessibility to the equipment after installation.

3

Remove the Shipping Restraints



You do not need to remove the radome in order to remove the shipping restraints.



Exercise caution when handling the antenna after removing the shipping restraints. Improper handling may damage the unit.

1. At the bottom of the antenna baseplate, cut the two tie-wraps and pull them out of the baseplate tie-wrap holes. **You do not need to remove the radome.** The tie-wraps secure the antenna mechanism to prevent shipping damage.

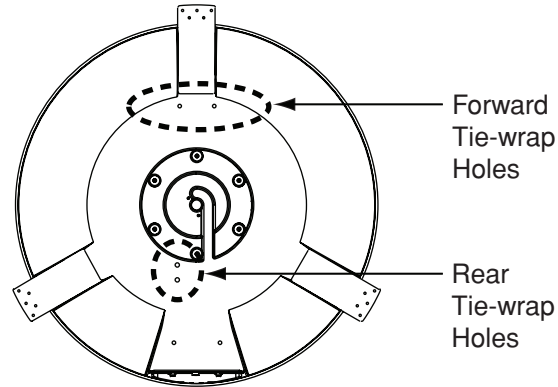

Tie-wrap Hole Locations on Baseplate (Bottom View)

2. After removing the tie-wraps, seal the four tie-wrap holes with the plugs provided in the kitpack.

4a

Mount the Antenna (Standard)

You can mount the antenna with the baseplate connectors facing the rear of the vehicle (standard orientation), or with the baseplate connectors facing the front of the vehicle (alternate orientation). Follow the steps below to mount the antenna in the standard orientation. To mount the antenna in the alternate orientation, skip to "Mount the Antenna (Alternate)" on page 6.

1. Place the antenna on the roof on the centerline of the vehicle, ensuring the arrow on the antenna's front mounting plate faces the front of the vehicle.

Top View

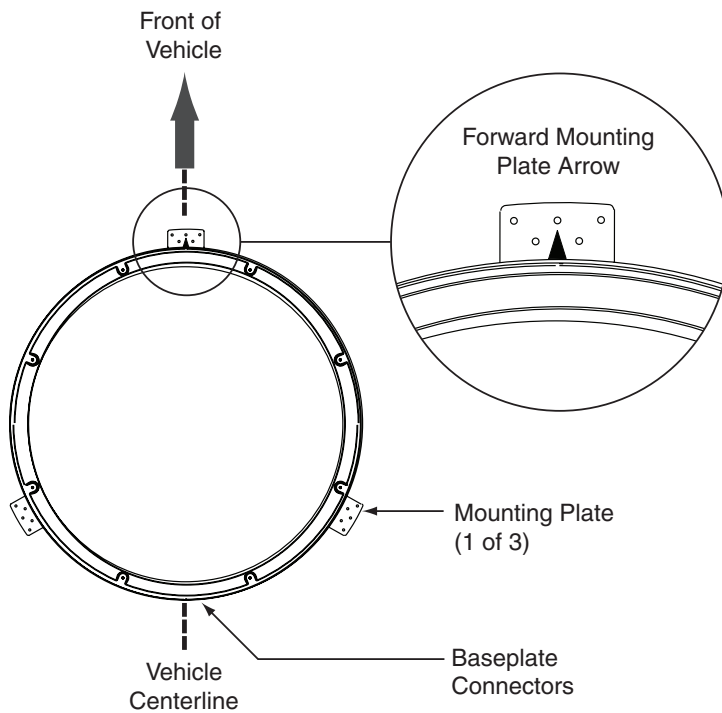

Side View

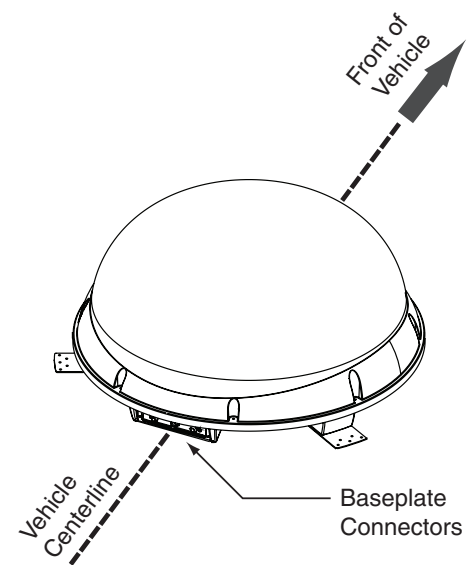

Standard Antenna Orientation

2. Apply construction adhesive to the bottom of the antenna's three mounting plates, across all holes.
3. Attach the three mounting plates to the roof using 15 fasteners appropriate for the roof's construction.
4. Seal all fasteners with silicone sealant or equivalent.



Due to the variation in RV roof construction, consult with the RV manufacturer to determine the safest fastening method.

Mount the Antenna (Alternate)



(Alternate Orientation Only)

You **MUST** drill out the drain holes as indicated to ensure that any moisture that enters the baseplate is able to drain. Ensure that the factory-drilled holes are completely sealed.

If you wish to mount the antenna with the baseplate connectors facing the front of the vehicle (alternate orientation), you will need to remove the radome, drill drain holes in the antenna baseplate, then seal the existing factory-drilled drain holes. Follow the steps below to mount the antenna in the alternate orientation.

1. Remove the eight screws and washers securing the radome to the baseplate. Carefully lift the radome up until clear of the antenna assembly and set aside.
2. Drill out three 3/16" (5 mm) drain holes in the rear-facing side of the baseplate. Then plug the four existing factory-drilled drain holes with silicone sealant.

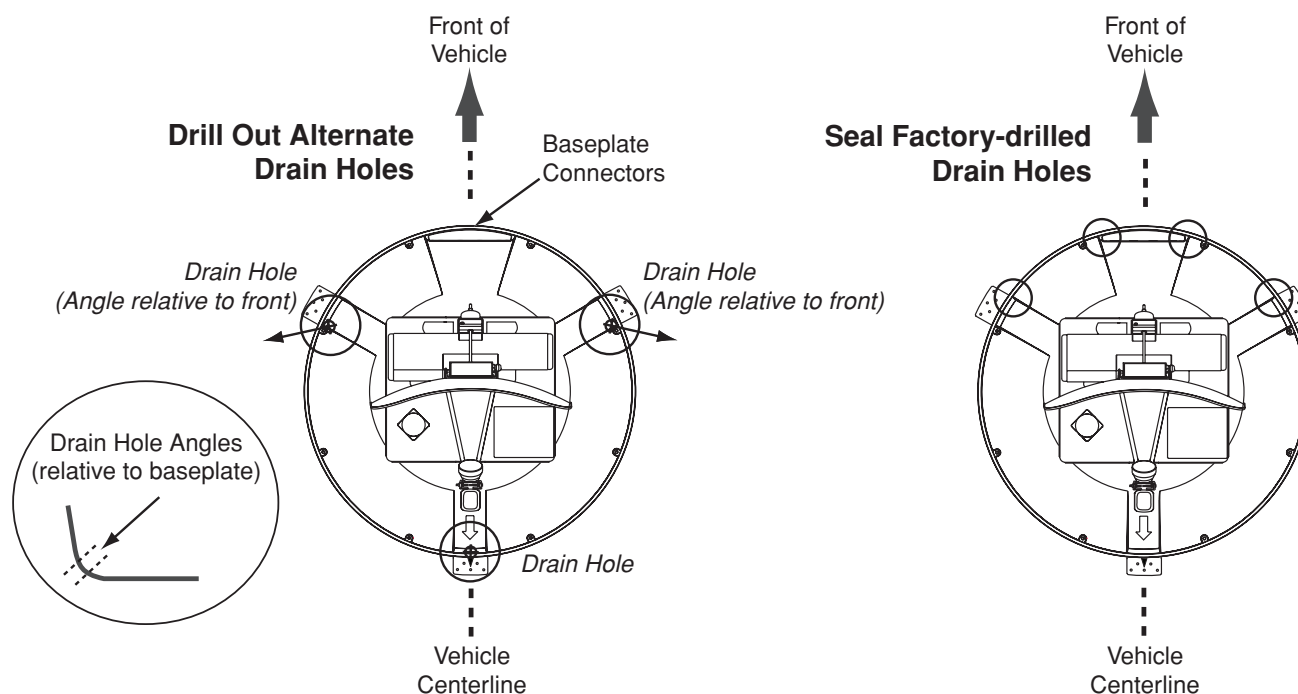

Alternate Antenna Orientation/Drain Hole Locations

3. Reinstall the radome, then place the antenna on the roof on the centerline of the vehicle, ensuring the baseplate connectors face the front of the vehicle.
4. Follow Steps 2, 3, and 4 of "Mount the Antenna (Standard)" on page 5 to complete the antenna mounting procedure.

5 Cut the Switchplate Mounting Hole

1. Find a dry, flat location inside the vehicle within 27 feet of the antenna to mount the switchplate.
The switchplate must be easily accessible to the user.
2. Using the template supplied in *Appendix F* on page 33, cut out the switchplate mounting hole in the mounting surface.



A full-scale panel cutout template has been provided for you in Appendix F on page 33.

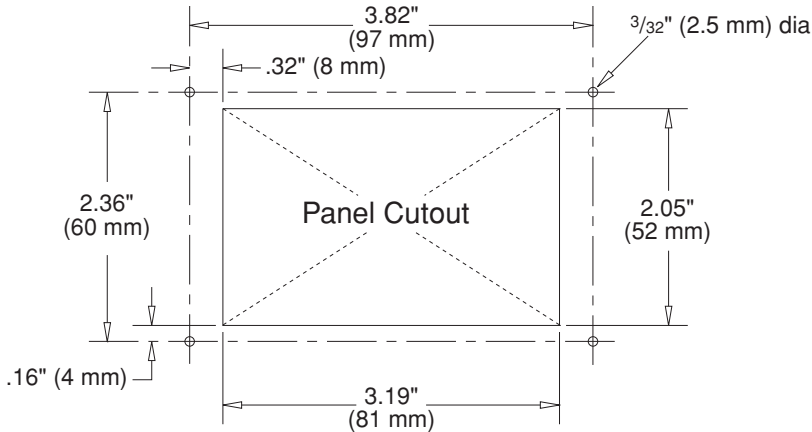

Switchplate Cutout Dimensions



Be sure to consider the 28-foot length of the data/power cable when choosing a location for switchplate. If you require a longer cable, an additional power supply **MUST** be used. Failure to install an additional power supply when a longer cable is used can result in serious damage to the antenna unit. KVH offers several cable packages:

45' Cable with Power Supply
KVH Part # 72-0143-45

60' Cable with Power Supply
KVH Part # 72-0143-60

45' Cable without Power Supply
KVH Part # 32-0730-45

60' Cable without Power Supply
KVH Part # 32-0730-60

Power Supply
KVH Part # 19-0402

6 Wire the Antenna

1. Drill a 3/4" hole in the roof for the cable access hole. Smooth the edges of the hole to prevent chafing of the cable.
2. Connect the antenna data/power cable to the antenna's center connector and lock in place.

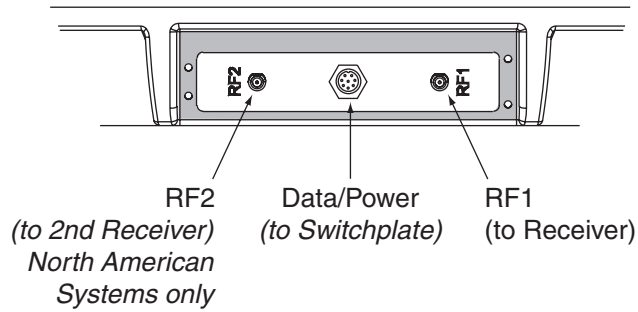

Antenna Baseplate Connectors

3. Connect one RF cable to the antenna's "RF1" connector. Hand-tighten first, then tighten with a 7/16" wrench for 1/4 turn.
4. Slide the rubber sealing boot up the RF cable until it covers the connector. This boot will help protect the connector from the elements.
5. *(North American Systems Only)* - If you plan to connect more than one receiver, connect a second RF cable to the "RF2" connector, then slide the rubber sealing boot up the RF cable.
6. Route the cables down through the cable access hole in the roof. Be sure to maintain a service loop (approximately 8") on the roof to allow plenty of slack.
7. Route the data/power cable to the switchplate location inside the vehicle.
8. Route the RF1 cable to the receiver. If you connected a second RF cable, route the RF2 cable to the second receiver.



Leave the protective cap installed on the RF2 connector unless connecting a second RF cable.



(North American Systems Only)
If you need to connect three or more receivers, refer to Appendix B on page 22.

7 Seal the Cable Access Hole

1. Seal the cable access hole with a liberal amount of silicone sealant, RTV, or equivalent to protect against leakage.
2. Install the clamshell ventilator, supplied in the kitpack, over the cable access hole using three of the supplied #6 screws.

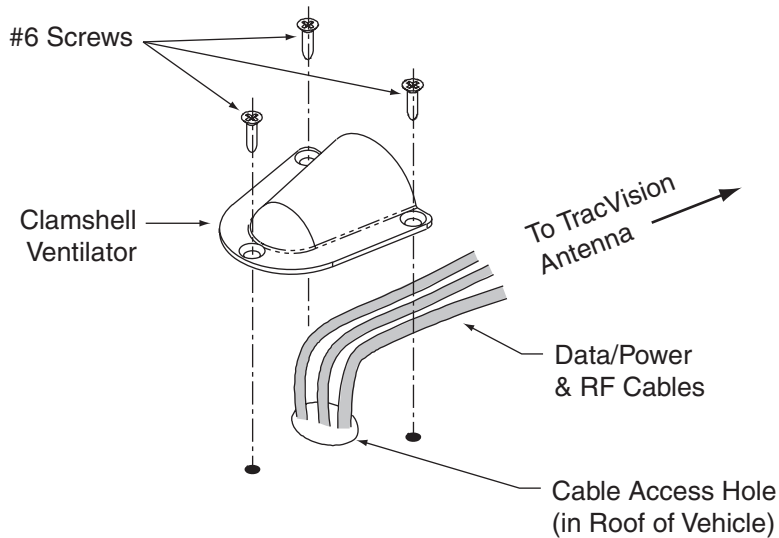

Installing the Clamshell Ventilator

8 Wire the Receiver(s)



Do not use a screw-on, push-on, or twist-on connector. Low quality connectors will degrade system performance and allow water/rain to penetrate the cable.

If you cut the RF cable(s), be sure to use an Augat IT1000 crimp/strip tool (KVH Part # 19-0242) to attach an F-connector.

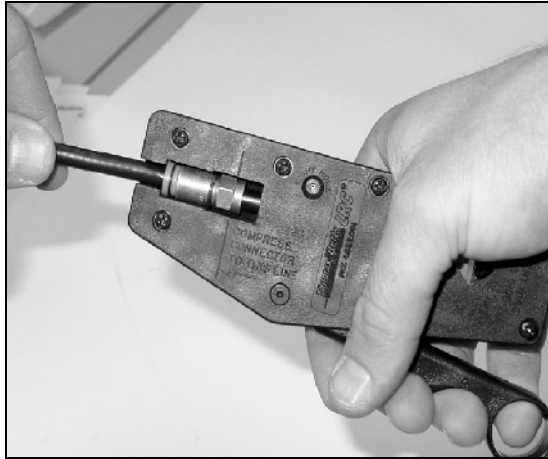

Augat IT1000 Crimp/Strip Tool and F-connector

1. Connect the RF1 cable to the receiver's "Satellite In" connector.

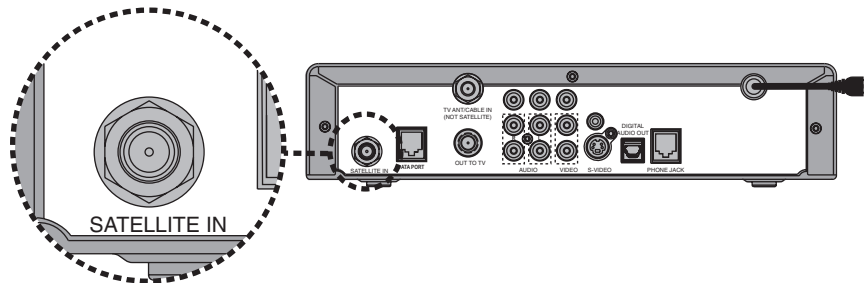

Receiver "Satellite In" Connector (Example)

2. Connect one end of the supplied ground wire to any suitable screw on the receiver's rear panel with a good contact with the receiver chassis. Route the other end to the switchplate location.
3. If you need to connect a second receiver, connect the RF2 cable and a second ground wire to the second receiver. If you need to connect more than two receivers, you will need to install an active multiswitch; see *Appendix B on page 22*.

9 Wire the Switchplate

The TracVision system requires an 11-16 VDC power input. A quick-tripping circuit breaker should be installed between the switchplate and vehicle power. Circuit overload protection should be rated for 5 amps. If vehicle power fluctuates widely or is noisy, a 12 VDC 5-amp AC/DC power supply should be installed (*KVH Part # 19-0402 or equivalent*).



Before wiring the switchplate, be sure to disconnect vehicle power by removing the appropriate vehicle fuse. Test the circuit to ensure that no power is present.

1. Disconnect vehicle power by removing the appropriate vehicle fuse. Test the circuit to ensure that no power is present.
2. Connect the antenna's data/power cable to the switchplate's data/power connector and lock in place.

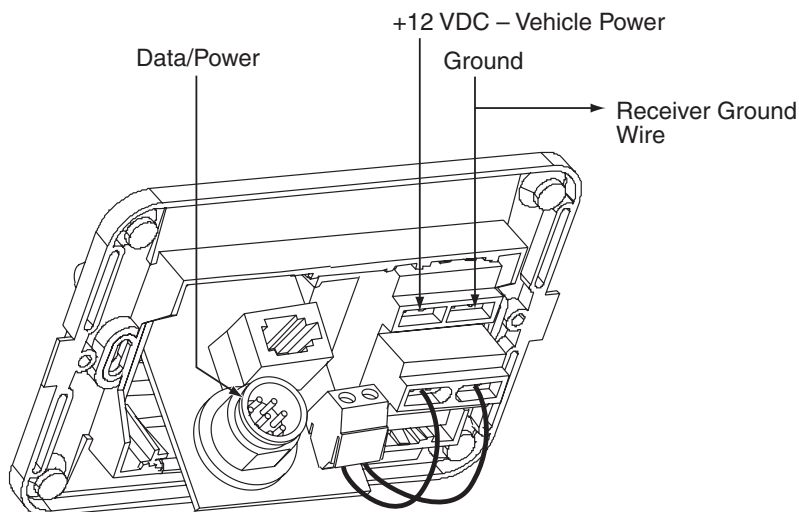

Switchplate Connections

3. Connect the receiver ground wire(s) to the switchplate's ground terminal, as shown above.
4. Connect the switchplate to vehicle power and ground, as shown above.

10 Mount the Switchplate

1. Fit the switchplate flush into the switchplate panel cutout that you made earlier.

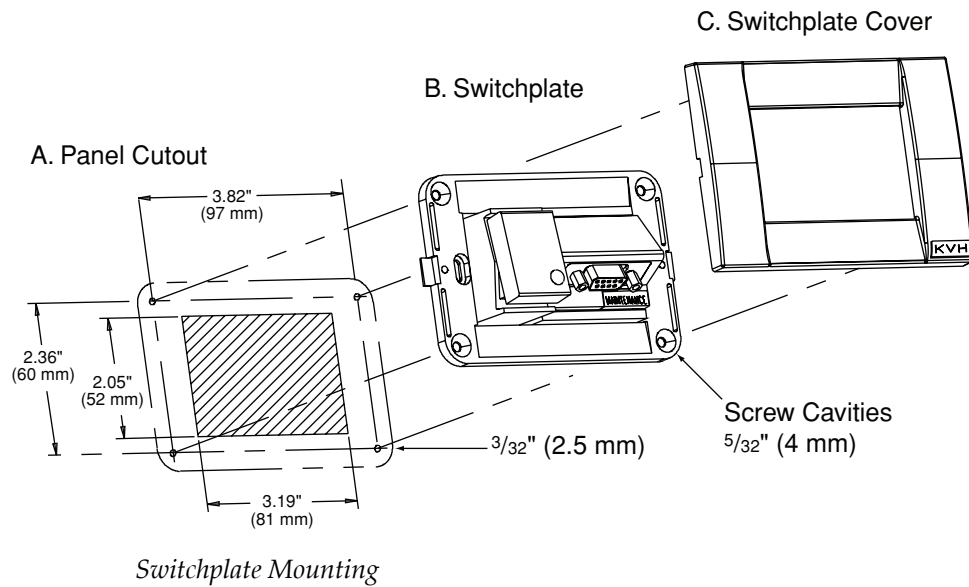

2. Drill out four 5/32" (4 mm) holes in the screw cavities in the switchplate.
3. Drill four 3/32" (2.5 mm) holes in the mounting surface using the switchplate screw cavities as the template. Then secure the switchplate assembly to the mounting surface using four #6 self-cutting screws.
4. Gently snap the switchplate cover onto the switchplate.
5. Reconnect vehicle power. Be sure to replace the vehicle fuse that you removed earlier.

11a Install Satellites (DISH 311 Receivers Only)

The following instructions explain how to install satellites for DISH Network service for use with DISH 311 receivers only. DISH Network does not currently support the use of any other receivers for mobile customers. *This procedure does not require a PC. To install satellites for any other receiver model, proceed to "Install Satellites" on page 14.*



Ensure that the vehicle is parked in a blockage-free area. The antenna must have a clear view of the sky to receive satellite TV.

1. Turn on the TV and primary receiver (the receiver connected to RF1).
2. Set the switchplate's POWER switch to the ON (up) position. Wait one minute for system startup.
3. Using the receiver remote control, go to the "Point Dish/Signal Strength" screen (press MENU, 6, 1, 1).
4. Choose "Check Switch" then press SELECT.
5. Choose "Test" then press SELECT to run the Check Switch function. Wait **15 minutes** for the antenna to install and find both DISH satellites.
6. Choose "Test" then press SELECT to run the Check Switch function a second time.
7. Once the second Check Switch function is complete, ensure the TV display appears **exactly** as shown below:

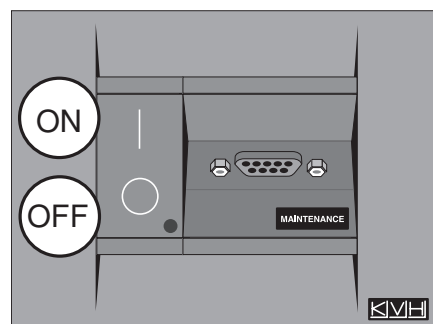

TracVision Switchplate

Installed Switch: SW42				
Input:	1	1	2	2
Satellite:	119	119	110	110
Polarity:	Odd	Even	Odd	Even
Status:	Satellite reception verified			

If the TV display does not appear exactly as shown, run the Check Switch function again.

8. Exit the menu and allow the receiver to download the program guide.
9. The procedure is complete! Skip to "Test the System" on page 18.

11b Install Satellites



The TracVision system is preconfigured to track one of the following satellite pairs:

Europe:

- ASTRA1 (Sat. A)
- HOTBIRD (Sat. B)

N. America

- DIRECTV_101 (Sat. A)
- DIRECTV_119 (Sat. B)

If your TracVision system is preconfigured to track your desired satellite pair (see sidebar at left), skip to “Test the System” on page 18. To select a different satellite pair, you will need to connect a PC to the antenna and start the KVH Flash Update Wizard. This procedure requires a PC with the Flash Update Wizard installed. The Flash Update Wizard is available to KVH-authorized dealers through the KVH Partner Portal.

Customers who wish to change the satellites that the TracVision system tracks can visit any KVH-authorized dealer/distributor. The new satellites can be configured in a just a few minutes.

1. Connect one end of the supplied PC data cable to the DB9 maintenance port connector on the switchplate. Connect the other end to the serial port on your PC.

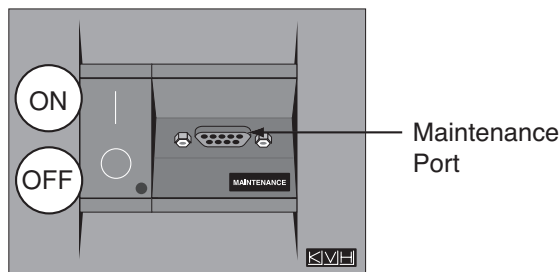

TracVision Switchplate



2. Double-click the KVH Flash Update Wizard shortcut on your computer’s desktop to start the Flash Update Wizard. *You do not need to flash the antenna; you will simply enter commands in the “TracVision Antenna Comms” window.*

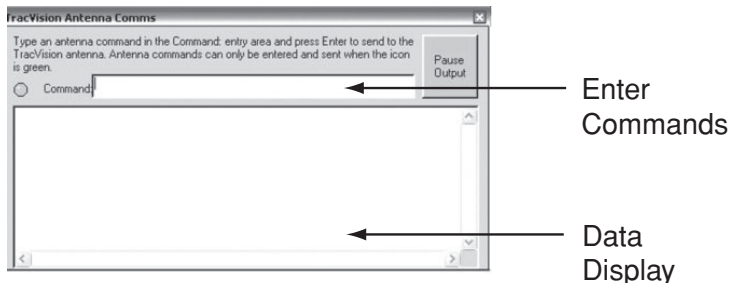

TracVision Antenna Comms Window



If your computer does not have a DB9 serial COM port, you can use the following USB-to-RS232 adapter:

IOGear Part # GUC232A
(visit www.iogear.com)

3. Set the switchplate’s POWER switch to the ON (up) position, then turn on the receiver(s). Wait one minute for system startup.

Follow the steps below to select which satellites to track. Enter all commands in the "TracVision Antenna Comms" window.

4. Type **HALT** then press Enter.
5. Select any two satellite names from either the North American or European satellite library. Also, be sure you are located within your selected satellite's coverage area. Visit www.kvh.com/footprint for satellite coverage maps. *If your desired satellites are not listed, you may also add any two satellites of your choice. To add satellites to the library, skip to Appendix C on page 23.*
6. Type the following command (see the Key below) then press Enter.

SATINSTALL,<sat_a_name>,<sat_b_name>

Key:	<p><sat_a_name> = the name of your choice for Satellite A</p> <p><sat_b_name> = the name of your choice for Satellite B (type NONE as the name of satellite B if you wish to install only one satellite)</p>
------	---

NOTE: To receive DISH 500 service, install the following two satellites: ECHO_119 & ECHO_110.

7. Type **ZAP** then press Enter to restart the antenna. Wait one minute for the antenna to initialize.

Example:

To assign ASTRA2S and HOTBIRD for your satellite pair (where ASTRA2S is designated as Satellite A and HOTBIRD is designated as Satellite B):

Type **HALT** then press Enter.
 Type **SATINSTALL,ASTRAS2S,HOTBIRD** then press Enter.
 Type **ZAP** then press Enter.

Be sure the receiver's satellite configuration matches your TracVision system's settings. Your choice for Satellite A or B must be the same satellite as Receiver Alternative 1 or 2, respectively (or Receiver Alternative A or B, respectively), based on your receiver, and must be assigned the Receiver DiSEqC 1 or 2 setting, respectively**. Refer to your selected receiver's user manual for details.

**DiSEqC settings apply only to European systems.

Satellite Installation Names

Satellite	Install Name
North American Satellites[†]	
DIRECTV 72.0° W	DSS_72
DIRECTV 101.0° W	DSS_101
DIRECTV 119.0° W	DSS_119
EHOSTAR 61.5° W	ECHO_61
EHOSTAR 110.0° W	ECHO_110
EHOSTAR 119.0° W	ECHO_119
EXPRESSVU 82.0° W	EXPRESSVU
EXPRESSTV 91.0° W	EXPRESSTV
PAS9 58°W	PAS_9 ^{††}

European Satellites

ARABSAT 26.0° E	ARABSAT
ASTRA1 19.2° E	ASTRA1
ASTRA2N 28.2° E	ASTRA2N
ASTRA2S 28.2° E	ASTRA2S
EUTELSAT W3A 7.0° E	EUTEL_W3A
HISPASAT 30.0° W	HISPASAT
HOTBIRD 13.0° E	HOTBIRD
HOTBIRDWB 13.0° E	HOTBIRDWB
NILESAT 101 7.0° W	NILESAT
SIRIUS 5.0° E	SIRIUS
THOR 0.8° W	THOR
TURKSAT1C 42.0° E	TURKSAT1C

Other Satellite Designations

USER-DEFINED 1	USER1 ^{†††}
USER-DEFINED 2	USER2 ^{†††}
NONE	NONE

[†]In N. America, you can also receive and decode signals from the DIRECTV 110 satellite if a KVH HDTV converter (KVH Part # 01-0260-05) is installed.

^{††}Unlike other N. American satellites, PAS9 service requires a linear (European-style) LNB. Follow the additional instructions for European systems within this guide to install the PAS9 satellite.

^{†††}USER1 and USER2 will only be available if one or two user-defined satellites have been added to the library (see Appendix C on page 23).

12 Find the Skew Angle (Europe Only)

Approximate Latitude/Longitude

Grid #	Latitude	Longitude
1	67°N	7°W
2	67°N	7°E
3	67°N	22°E
4	65°N	44°E
5	63°N	7°W
6	63°N	7°E
7	63°N	22°E
8	57°N	7°W
9	57°N	7°E
10	57°N	22°E
11	55°N	40°E
12	53°N	7°W
13	53°N	7°E
14	50°N	22°E
15	47°N	7°W
16	47°N	7°E
17	43°N	7°W
18	43°N	7°E
19	43°N	22°E
20	43°N	37°E
21	36°N	7°W
22	36°N	7°E
23	36°N	22°E
24	36°N	37°E

To optimize channel reception, you need to set the LNB skew angle. Refer to your satellite service provider for the proper skew angle for your specific satellite service and geographic location. You can also find the skew angle for satellites in the TracVision R5/R4 satellite library by entering your latitude and longitude into the antenna. You can use the grid below to determine your approximate latitude/longitude.

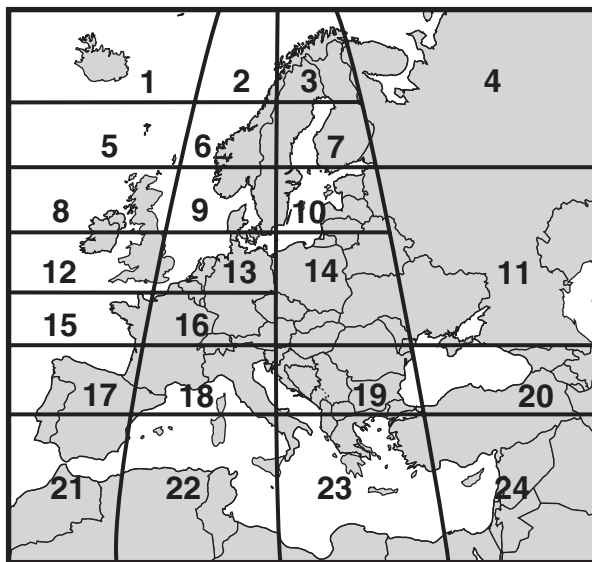

To determine your approximate latitude/longitude, match the grid # above for your location with the corresponding grid # at left.

Finding the Skew Angle for Satellites in the Satellite Library

1. Type **HALT** then press Enter.
2. Type **DEBUGON** then press Enter.
3. Type the following command (see the Key below) then press Enter.

GPS,XX,D,YYY,E

Key:	XX = latitude (0-90)
	D = S (South) or N (North)
	YYY= longitude (0-180)
	E = E (East) or W (West)

4. Type **SKEWANGLE** then press Enter. The TracVision system will respond with the skew angle for the currently selected satellite.

13 Set the Skew Angle (Europe Only)

1. Turn off the antenna and remove the appropriate vehicle fuse to disconnect power. Ensure power is removed from both the antenna and the receiver(s) or multiswitch connected to RF1.
2. Remove the eight screws securing the radome. Remove the radome and set it aside in a safe place.

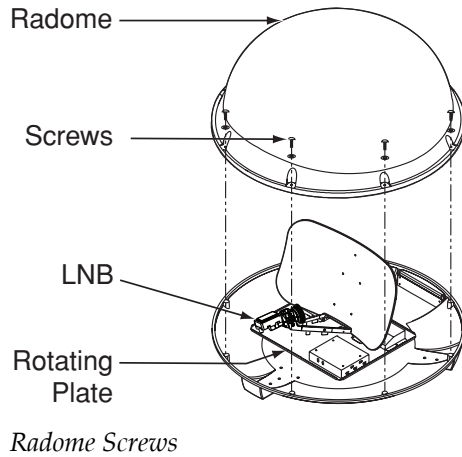

3. Using a 9/64" allen wrench, loosen the two LNB bracket screws securing the LNB in the following way: loosen one screw one full turn, then loosen the second screw one full turn; repeat until the LNB can be rotated freely.

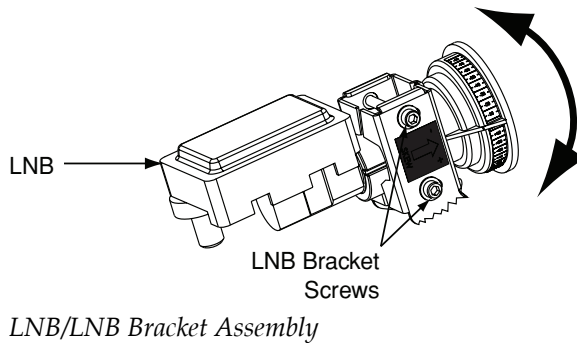

4. Rotate the LNB to align the skew arrow with the skew angle that you determined earlier, then tighten the screws (in the same manner that you loosened them) until the LNB no longer rotates. Then turn each of the two screws an additional 1/4 turn.
5. Reinstall the radome and restore vehicle power. Be sure to replace the vehicle fuse that you removed earlier.



Before servicing the antenna unit, turn off the antenna and disconnect vessel power. Ensure power is removed from both the antenna and the receiver(s) or multiswitch connected to RF1.



IMPORTANT

Be sure to alternate the loosening or tightening of the LNB bracket screws. Turn one screw one full turn, then turn the second screw one full turn, until the operation is complete. Failure to do so might cause unequal pressure on the LNB and impair signal reception.

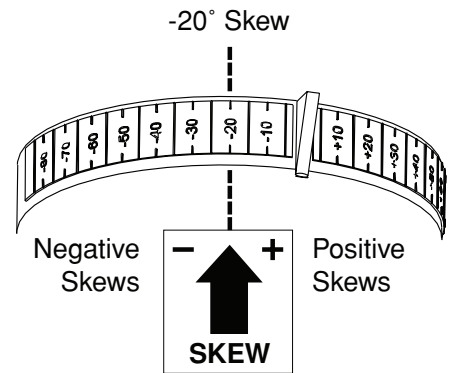

Align the Skew Arrow with the Skew Angle that You Determined Earlier

Test the System

Now all you need to do is turn the system on and ensure everything works properly. Follow the steps below to test the TracVision system.

1. Park the vehicle in a blockage-free area. The antenna requires an unobstructed view of the sky to receive satellite signals.
2. Turn on the receiver(s) and TV(s). For details on operating the receiver, refer to your selected receiver's user manual.
3. Set the switchplate's POWER switch to the ON (up) position to turn on the TracVision system. Wait one minute for the antenna to initialize.

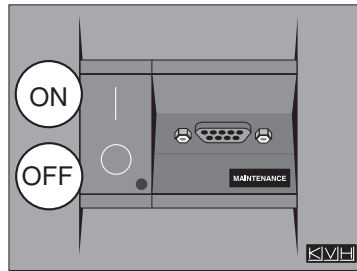

TracVision Switchplate

4. Within a few minutes, a picture should appear on the TV.
5. (*TracVision R5 Only*) Take a road test and verify that the antenna tracks the satellite while the vehicle is moving.
6. When you have finished testing, shut down the system. Be sure to leave the *User's Guide* and the *Product Registration Form* inside the vehicle for the customer.

Refer to the *User's Guide* for additional information

The *User's Guide* contains detailed information on the following:

- Operational instructions
- Troubleshooting information
- DISH 500 configuration

15 Educate the Customer

Be sure to give the manuals to the customer and explain how to use the product. The customer also needs to know the following:

- The receiver must be activated before it can receive satellite TV programming.
- Keep the radome installed on the antenna at all times. The radome protects the antenna's internal moving parts from wind, rain, and debris.
- The antenna must have a clear view of the sky to receive satellite TV. Common causes of blockage include trees, buildings, overpasses, and mountains. The TracVision antenna will not work inside a garage.

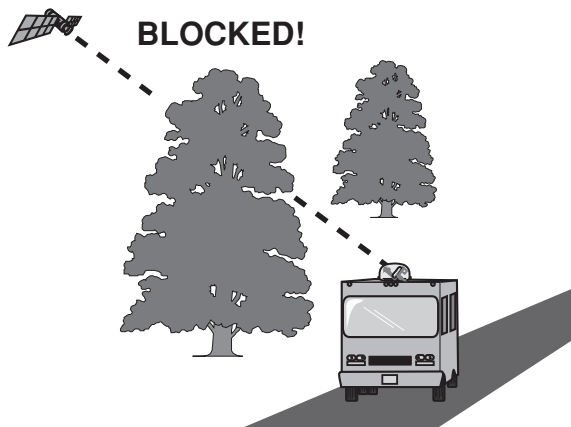

Blockage Example

- Heavy rain or snow may temporarily interrupt satellite reception.
- The antenna should be cleaned periodically. Dirt buildup on the radome can affect satellite TV reception.
- The owner needs to register the system for product warranty validation. Refer to the *Product Registration Form* for details or visit: www.kvh.com/register.
- The vehicle must be located within the selected satellite's coverage area in order to receive its satellite TV signals. To view satellite coverage maps, visit www.kvh.com/footprint.
- Refer to the *User's Guide* for complete operation instructions.



IMPORTANT:

The customer must activate the receiver to watch satellite TV.

*To activate a **DIRECTV** receiver, call KVH at 1-888-584-4163.*

*To activate a **DISH Network** receiver, call 1-800-333-DISH.*

*To activate an **ExpressVu** receiver, call 1-888-SKY-DISH.*



KVH offers an upgrade kit (KVH Part # 72-0218) that adds in-motion tracking capability to the TracVision R4, allowing you to receive satellite signals while on the move.



*If you need to paint the radome, **use ONLY non-metallic automotive paint without a primer coat.** Metallic paint or paint having metallic color will block satellite signals.*

Appendix A System Specifications

Physical Characteristics

Power	11-16 volts DC @ 2.5 amps nominal, 3.5 amps peak
Dimensions/Weight	32" (81 cm) wide x 14.8" (38 cm) high, 33 lbs (15 kg)
LNB	European system: Single output N. American system: Dual output
Maintenance Port	EIA, RS232 @ 9600 bps,8,N,1

Pointing System

Elevation Range	10° to 70°
Azimuth Range	720°
Position Repeatability	0.1°

Environmental

Operating Temperature	-25°C to +55°C (-13°F to +131°F)
Storage Temperature	-40°C to +85°C (-40°F to +185°F)
Humidity	to 100 percent

Appendix B Installing 3+ Receivers



Instead of grounding individual receivers, you can simply ground the multiswitch.



The TracVision R5/R4 has the capability of switching from one satellite to another when you choose TV channels that are carried by your two selected satellites. However, the use of an active multiswitch interferes with communication from the receivers to the antenna. In this case, you will need to use the optional TV/SAT Switch or the optional HDTV Converter's control panel.

To order a TV/SAT Switch (KVH Part # 01-0245) or a HDTV Converter (KVH Part # 01-0260-05), please call +1 401 847-3327.

(North American Systems Only)

If you need to connect three or four receivers, install an active multiswitch (KVH Part # 19-0123, Channel Master model 6214IFD, or equivalent). Install the multiswitch between the antenna unit and the receivers as shown below. If you need to connect more than four receivers, contact KVH for additional wiring instructions.

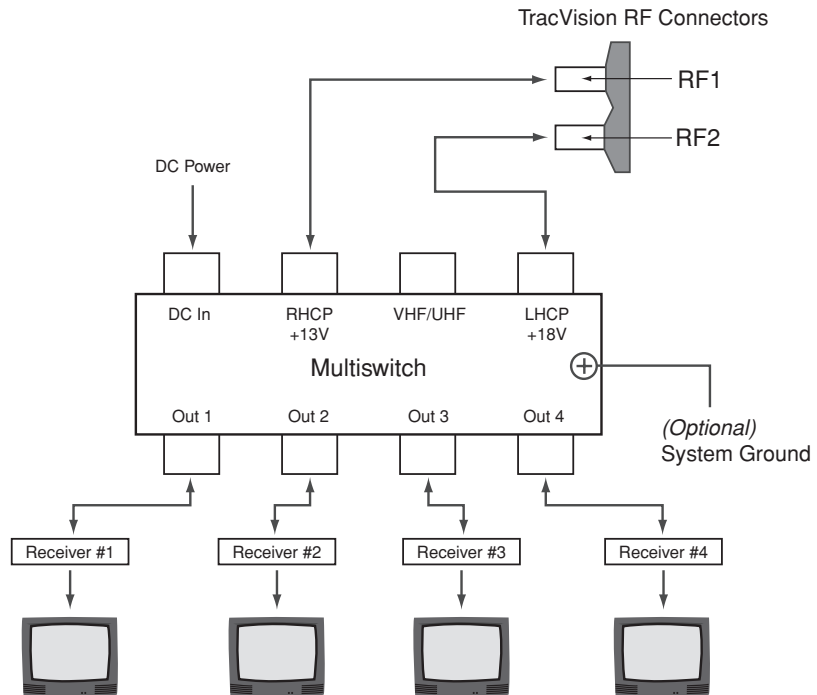

Appendix C User-defined Satellites

The TracVision R5/R4 satellite library has two vacancies that you may use to program two user-defined satellites, in case you want to install/watch a satellite not already in the KVH satellite library. To install a user satellite, you will need to obtain the following satellite information from your satellite service provider, or from sites on the Internet, such as www.satcodx.com:

- Satellite name
- Satellite position (longitude)
- Transponder information for each of the following polarizations/frequencies:
 - vertical high & vertical low
 - horizontal high & horizontal lowor
 - right
 - left
- Transponder information includes:
 - frequency
 - symbol rate
 - FEC code, and
 - network ID (in hexadecimal format)
- Decoder type

Follow the steps below to install your user-defined satellite.

1. Connect with the Flash Update Wizard, as described in *“Install Satellites”* on page 14.
2. Type **HALT** in the TracVision Antenna Comms window, then press Enter.

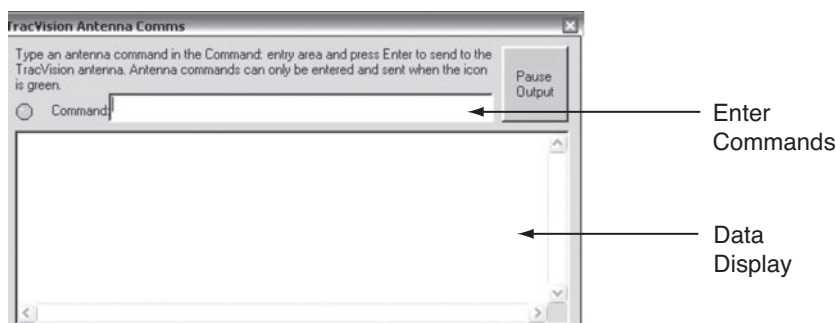

TracVision Antenna Comms Window

Appendix C User-defined Satellites

3. Type the following command (see the Key below) then press Enter.

SATCONFIG,USERX,YYY,Z,D,L

Key:	X = 1 or 2 (This represents the first or second user-defined satellite. Your TracVision system allows up to two user-defined satellites.)
	YYY= longitude (0-180)
	Z = E (East) or W (West)
	D = decoding type (1 = DSS-A, 2 = DSS-B, 3 = DVB)
	L = LNB polarization (C = circular, L = linear)

The main board has now been configured to recognize the user-defined satellite. Next, you need to configure the RF board.

4. Type **@DEGUGON** then press Enter.
5. Type the following command (see the Key below) then press Enter.

@SATCONFIG,X,N,F,S,C,ID,P,B,D

Key:	@SATCONFIG = directs data to the RF board
	X = satellite location A or B
	N = 98 User-defined slot 1 (USER1) 99 User-defined slot 2 (USER2)
	F = frequency in MHz (either 00000 or a range from 10700 - 12700)
	S = satellite transponder symbol rate in Mbit/second (01000 - 29999)
	C = FEC code (e.g., 12, 23, 34, 56, 67, 78)
	ID = satellite network ID in hexadecimal format (0x####)
	P = LNB polarization (V - vertical, H = horizontal, R = right, L = left)
	B = LNB down conversion frequency (L = low, H = high, U = USA)
	D = decoding type (1 = DSS-A, 2 = DSS-B, 3 = DVB)

Appendix C User-defined Satellites

Transponder information has to be entered for each of the following polarizations/frequencies:

- vertical high & vertical low
- horizontal high & horizontal low

or

- right
- left

The TracVision R5/R4 antenna requires that the fields for all transponder categories be filled in. If the selected satellite does not have information for one or more of the transponder categories, default information should be entered in the fields as follows:

Transponder Data	Default Value
Frequency	00000
Symbol Rate	27500
FEC Code	the same value as provided for those transponders with data
Network ID	0x0000
Polarity and Band	whichever combinations are not already provided

6. Type **@SAVE,A** then press Enter to save your settings (or **@SAVE,B** if data is for the User2 satellite).
7. Type **@DEBUGOFF** then press Enter.
8. Type **ZAP** then press Enter. Wait one minute for the antenna to initialize.

One of your user-defined satellites has now been added to the satellite library and is now available for tracking. To begin tracking your user-defined satellite(s), refer to *“Install Satellites”* on page 14, and choose “USER1” or “USER2” in Step 6.

Appendix C User-defined Satellites

An Example of Configuring a User-defined Satellite (Europe)

The following is an example of configuring the fictional YOURSAT 101 as the USER1 configured satellite. Prior to configuring this satellite or any others, be certain to get the most up-to-date information from one of the sources previously discussed.

YOURSAT 101 at 7°, DVB decoder, Linear Polarization LNB

Horizontal High

Frequency	11.966 GHz
Symbol Rate	27500
FEC Code	3/4
Network ID	2048 (dec) = 0x0800

Vertical High

Frequency	11.823 GHz
Symbol Rate	27500
FEC Code	3/4
Network ID	2048 (dec) = 0x0800

Vertical Low

No Data Listed	
----------------	--

Horizontal Low

No Data Listed	
----------------	--

Example:

Based on this information, the data entered via the PC would look like this, assuming that YOURSAT 101 would be Satellite A:

```
SATCONFIG, USER1, 7, W, L
@DEBUGON
@SATCONFIG, A, 98, 11966, 27500, 34, 0X0800, H, H, 3
@SATCONFIG, A, 98, 11823, 27500, 34, 0X0800, V, H, 3
@SATCONFIG, A, 98, 00000, 27500, 34, 0X0000, V, L, 3
@SATCONFIG, A, 98, 00000, 27500, 34, 0X0000, H, L, 3
@SAVE, A
@DEBUGOFF
ZAP
```

Appendix C User-defined Satellites

An Example of Configuring a User-defined Satellite (N. America)

The following is an example of configuring the fictional YOURSAT 101 as the USER1 configured satellite. Prior to configuring this satellite or any others, be certain to get the most up-to-date information from one of the sources previously discussed.

YOURSAT 101 at 71°, DVB decoder, Circular Polarization LNB

<i>Right</i>	
Frequency	11.966 GHz
Symbol Rate	27500
FEC Code	3/4
Network ID	2048 (dec) = 0x0800
<i>Left</i>	
Frequency	11.823 GHz
Symbol Rate	27500
FEC Code	3/4
Network ID	2048 (dec) = 0x0800

Example:

Based on this information, the data entered via the PC would look like this, assuming that YOURSAT 101 would be Satellite A:

```
SATCONFIG,USER1,71,W,3,C
@DEBUGON
@SATCONFIG,A,98,11966,27500,34,0X0800,R,U,3
@SATCONFIG,A,98,11823,27500,34,0X0800,L,U,3
@SAVE,A
@DEBUGOFF
ZAP
```

Appendix D Replaceable Parts



If you experience an operating problem, refer to the “Troubleshooting” section of the User’s Guide. If you require technical assistance, please contact your local KVH-authorized dealer or distributor. You can find an authorized technician near you by visiting our website at www.kvh.com/wheretogetservice. If an authorized dealer/distributor is not located nearby, contact KVH Technical Support directly:

North America, South America, Australia:

Phone: +1 401 847-3327
 (Monday - Friday, 9:00 am - 6:00 pm,
 Saturday, 9:00 am - 2:00 pm EST,
 +5 GMT)
 E-mail: techs@kvh.com

Europe, Middle East, Asia:

Phone: +45 45 160 180
 (Monday - Thursday, 8:00 am -
 4:30 pm, Friday 8:00 am - 2:00 pm,
 -1 GMT)
 E-mail: support@kvh.dk

The TracVision R5/R4 system has been designed with durability and low maintenance in mind. If you experience an operating problem or otherwise require technical assistance, contact your local KVH-authorized dealer or distributor. If an authorized dealer/distributor is not located nearby, contact KVH Technical Support (see sidebar).

Replacement part numbers for units that can be serviced in the field are listed below. These parts can be replaced by any KVH-authorized dealer/distributor.

Field Replaceable Units

Part Name	Part Number
Baseplate Assembly (TracVision R5)	02-1474-03* 02-1474-01**
Baseplate Assembly (TracVision R4)	02-1474-04* 02-1474-02**
Radome Assembly (TracVision R5)	02-0953-12†
Radome Assembly (TracVision R4)	02-0953-11†
Data/Power Cable	32-0730-28
RF Cable	32-0819-28
PC Cable	32-0628-06
Main PCB	72-0211
RF PCB	72-0212
Gyro (TracVision R5 Only)	72-0215
System Fuses	16-0017-3150
LNB (North American Systems)	72-0213
LNB (European Systems)	72-0214
Switchplate	02-1023-01
TV/SAT Switch (optional)	01-0245

*Baseplate assembly with dual-output circular LNB (North American Systems)

**Baseplate assembly with single-output linear LNB (European Systems)

†Specify color when ordering

Appendix E Reshipping Instructions

If you need to repack the antenna unit for shipment, the two shipping restraints (tie-wraps) removed during installation must be replaced. The following instructions explain how to repack the TracVision R5/R4 antenna unit for shipping.

1. Remove the four plugs from the forward and rear tie-wrap holes on the bottom of the baseplate.

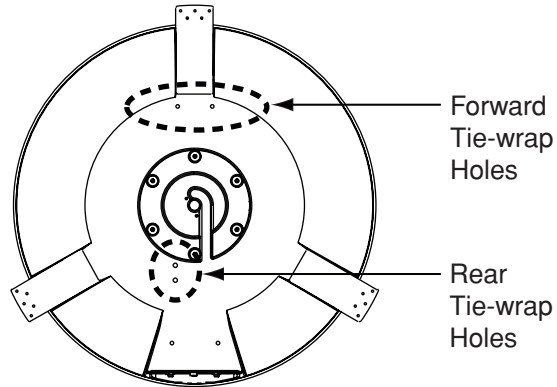

Antenna Baseplate (Bottom View)

2. Remove the eight screws securing the radome. Remove the radome and set it aside.

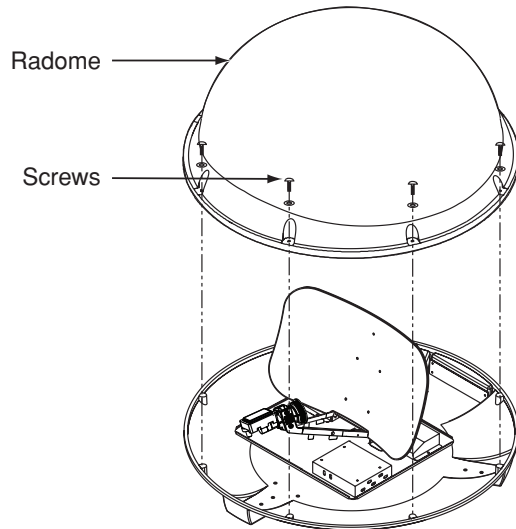

Radome Screws

Appendix E Reshipping Instructions

3. Gently rotate the rotating plate until the LNB is aligned with the forward mounting plate arrow.

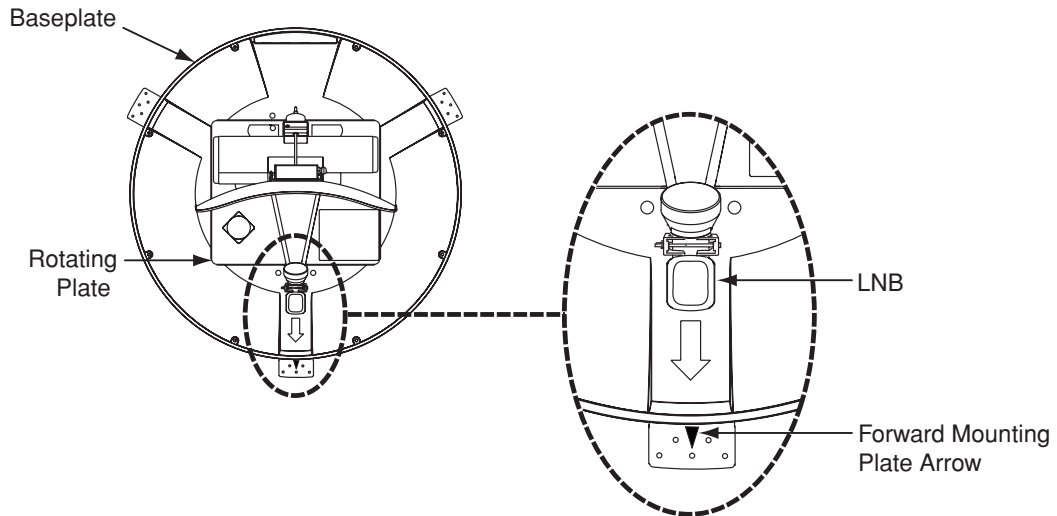

Reshipping Orientation



When moving the rotating plate by hand, go slowly! Hitting the mechanical stops with excessive force will damage the antenna unit.

4. Thread one tie-wrap through the rear tie-wrap holes and through the rotating plate, as shown below. Fasten the tie-wrap, ensuring the rotating plate is secured to the baseplate.

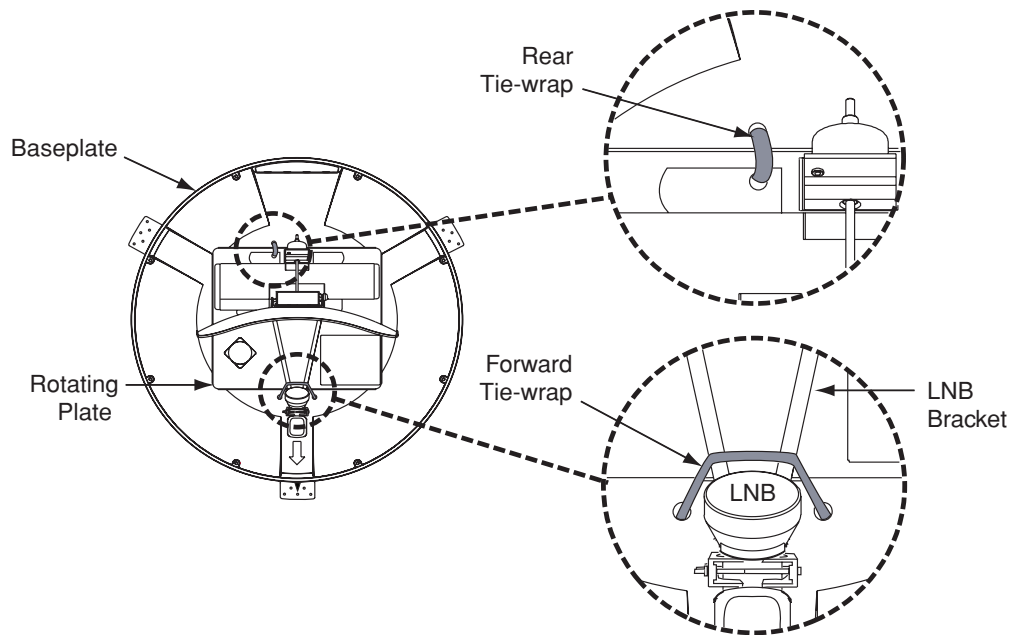

Tie-wrap Locations

Appendix E Reshipping Instructions

5. Thread a second tie-wrap through the forward tie-wrap holes and over the LNB bracket. Fasten the tie-wrap, ensuring the LNB bracket is secured to the baseplate. *Be sure to fasten the tie-wrap to the LNB bracket, and not the LNB.*
6. Reinstall the radome.
7. Place the entire antenna unit into its shipping box using the original packaging material. Secure the box to a pallet to ensure upright transport.

The repacking process is complete! The TracVision R5/R4 is now ready for reshipment.



Ensure that the tie-wrap is fastened to the LNB bracket, and not the LNB.



If you need to return the antenna, be sure to obtain an RMA number from KVH's Technical Support Department first. Be sure to write the number clearly on the outside of the box. Shipments received without an RMA number will be returned to you at your expense.

Appendix F Switchplate Template

