

IP80-Series

Seametrics

FLOW SENSOR INSTRUCTIONS

- IP81
- IP82



IP80-SERIES FLOW SENSOR INSTRUCTIONS

ISO 9001:2008
CERTIFIED

TABLE OF CONTENTS

General Information

Features, SpecificationsPage 3

Installation

Insertion Depth, Distorted Flows, Fitting Installation, Meter Installation, Positioning the Meter.....Page 4

Straight Pipe RecommendationsPage 5

Full Pipe RecommendationsPage 6

Connection Diagrams

FT415/FT420/A055, Connecting to PLC's.....Page 7

Operation

Minimum Flow, Flow Range Table, Calibration (“K-Factor”), Field Calibration.....Page 8

Maintenance

Rotor Replacement, Signal Troubleshooting, Sensor ReplacementPage 9

Parts Explosion

Parts ListPage 10

Troubleshooting

Problems, Probable Causes, To Check, To RepairPage 11

TABLES AND DIAGRAMS

Specifications, FeaturesPage 3

Distorted Flows, Positioning the MeterPage 4

Straight Pipe RecommendationsPage 5

Full Pipe RecommendationsPage 6

Connections DiagramsPage 7

Flow Range Table, K-Factor Number on Tee Fitting, K-Factor Chart, Pressure vs. Temp Chart.....Page 8

Rotor and Sensor ReplacementPage 9

Parts Explosion, Parts ListPage 10

Troubleshooting.....Page 11

GENERAL INFORMATION

The **IP80-Series** are impeller (or “paddlewheel”) insertion meters designed for use with a wide variety of liquids in pipe sizes 1/2" to 8". Sensors are available in brass, 316 stainless steel, PVC, and polypropylene. Bodies are machined from a solid rod for maximum precision. High-quality jewel bearings and nickel-bound tungsten carbide shafts are used for extreme low friction and long life. Low-flow performance is good, although other Seametrics flow meters are recommended where extremely low flows are being measured.

The rotation of the rotor is detected by a non-drag Hall-effect sensor. Output is a current-sinking pulse (square wave), which can be sent long distances (up to 2,000 feet) without a transmitter. This signal can be connected directly to PLC's, counters, and computer cards, as well as a variety of Seametrics controls and displays.

Seametrics IP meters are ideal for chemical proportioning applications. If no display is required, a simple divider such as the PD10 provides adjustable pump pacing. For rate and total display, the FT415 (battery powered) or FT420 (loop powered) flow indicator can be mounted directly on the IP80-Series meter, or remotely on a wall or panel. The AO55 blind analog transmitter can be used to convert to a 4-20 mA output. IP meters are also compatible with the DL76 data logger and FT520 batch processor.

The IP80-Series require special fittings that ensure correct depth placement in the pipe. Fittings come in a variety of materials for compatibility with specific applications. Tee fittings are individually wet-calibrated at the factory and marked with the K-factor (pulses per gallon). Saddle fittings must be field-installed on the pipe and do not come wet-calibrated. K-factors for saddles are based on factory-testing.

FEATURES

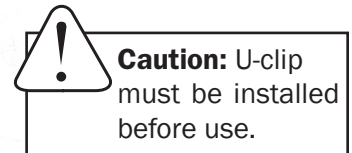
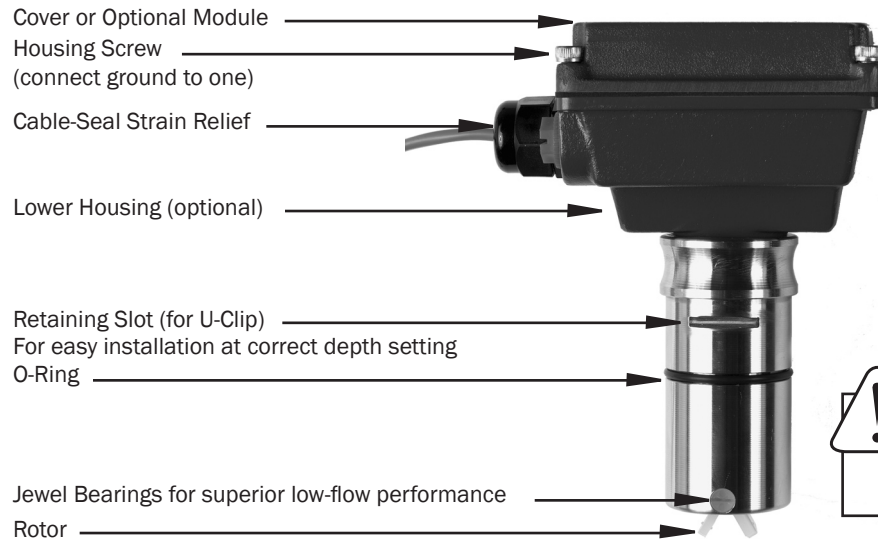

SPECIFICATIONS*

Materials	Sensor Body	Brass, 316 Stainless Steel, PVC, or Polypro		
	Rotor	PVDF		
	Shaft	Nickel-bonded tungsten carbide (Ceramic optional)		
	Bearings	Ruby jewel		
	O-Ring	EPDM (Viton optional)		
Rotor Pickup	GMR (Giant Magnetoresistive) Sensor			
Maximum Pressure	Brass	316 SS	PVC or Polypro (See Pressure vs. Temp. Chart)	
	200 PSI (14 bar)	250 PSI (17 bar)	175 PSI (12 bar) @ 75° F	
	Maximum Temperature	200° F (93° C)	200° F (93° C)	130° F (55° C)
Flow Range	0.3 - 30 ft./sec.			
Accuracy	+/- 1.5% of full scale			
Signal	Hall effect current sinking pulse			
Power	6-24 Vdc, 2 mA			
Maximum Current	20 mA			
Cable	#22 AWG, 3 Cond, 18 foot (maximum 2000' run)			
Regulatory	☞ Mark (Stainless Steel, Brass and Standard Power Only)			

*Specifications subject to change • Please consult our website for current data (www.seametrics.com).

INSTALLATION

Insertion Depth. The IP80-Series are fixed-depth meters that must be used with matched fittings appropriate to the application and pipe size. This ensures that the flow sensor is installed at the correct insertion depth to measure the average flow velocity of the stream.

Straight Pipe. Straight pipe of at least 10 diameters upstream and five diameters downstream of the meter is strongly recommended for proper accuracy. This is necessary because the shape of the velocity profile changes as the rate increases around an elbow; placing the meter too near the elbow causes a distorted reading. Additional straight run may be needed under specific adverse circumstances (see next page).

If you can't provide enough straight run to smooth out the velocity profile, some decrease in accuracy may result. This does not mean the meter's reading is meaningless, however. In some applications (e.g., control system, valve operation) a repeatable reading may be more important than a highly accurate one.

DISTORTED FLOWS

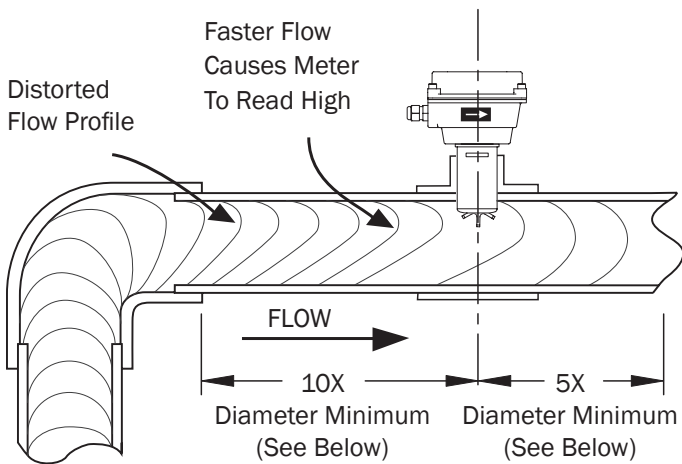

Fitting Installation. Stainless steel and brass fittings have female pipe threads, requiring the appropriate male threaded fittings. Saddle fittings require a hole to be cut in the pipe (recommended hole size is 1-3/4"). Before cutting into the pipe, observe the drawing below to choose your meter orientation.

POSITIONING THE METER

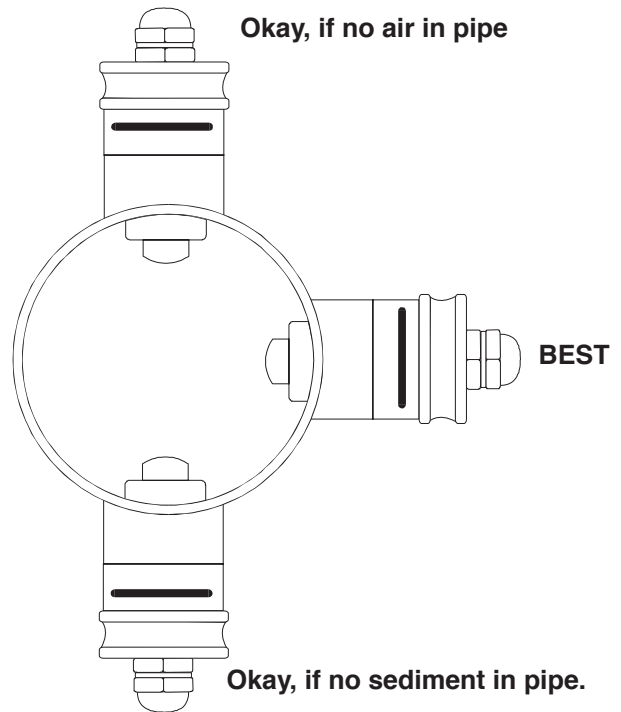

PVC Fittings. A PVC fitting is usually installed by solvent welding. PVC tees are supplied with some upstream straight pipe, less than the recommended straight pipe requirements. It is not advisable to connect directly to the end of these fittings with a flow disturbing device (valve, elbow), but rather add straight pipe to the end of these fittings to meet the straight pipe requirements for your application.

Meter Installation. After the meter fitting is installed in the pipeline, the meter can be installed in the fitting. Press the meter into the fitting as far as it will go. Retain the meter in place by inserting the u-pin. The pin can be installed from either side. It may be necessary to rotate the probe back and forth slightly to start the pin into the slots on the probe. Slide the pin in as far as it will go.



Caution: Never remove the u-clip retainer when the pipe is under pressure. Always remove pressure from the pipe before you attempt to remove the meter. Removal under pressure may result in damage or serious injury.

INSTALLATION

STRAIGHT PIPE RECOMMENDATIONS

(X = diameter)

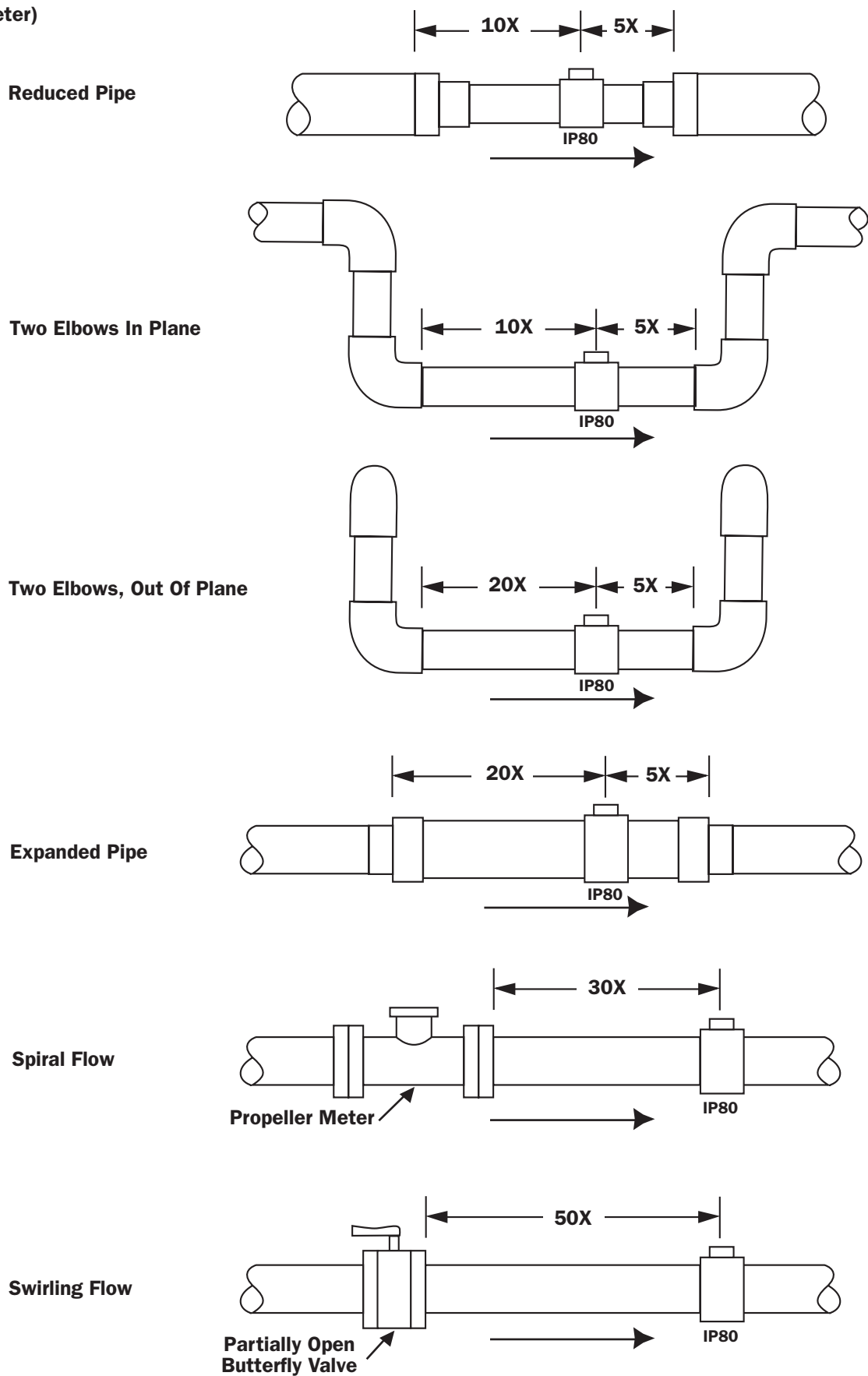

INSTALLATION

FULL PIPE RECOMMENDATIONS

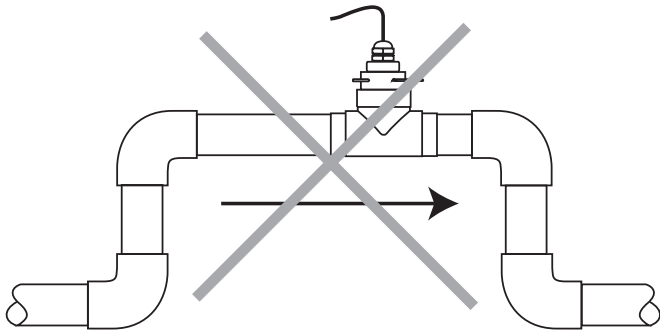

Possible Problem:
Allows air pockets to form at sensor

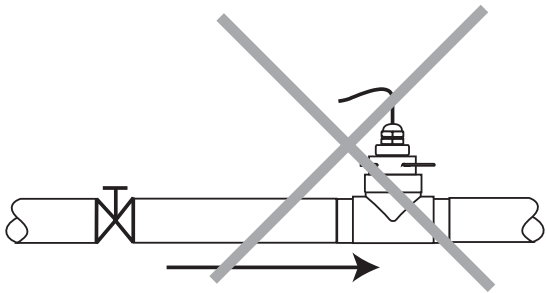
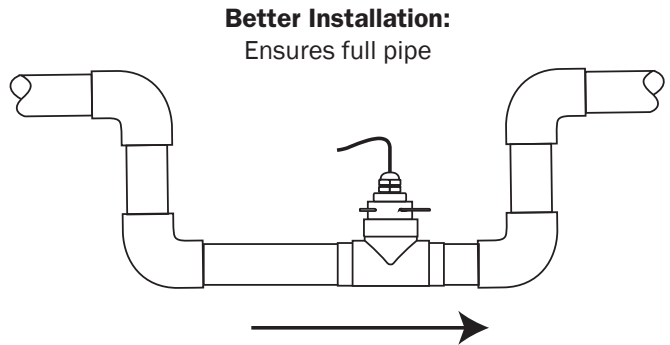

Possible Problem:
Post-valve cavitation can create air pocket

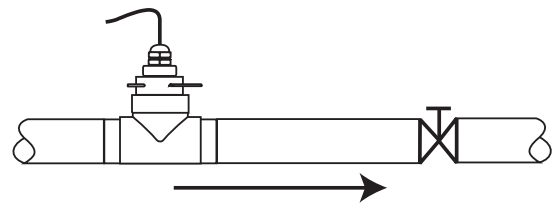

Better Installation:
Keeps pipe full at sensor

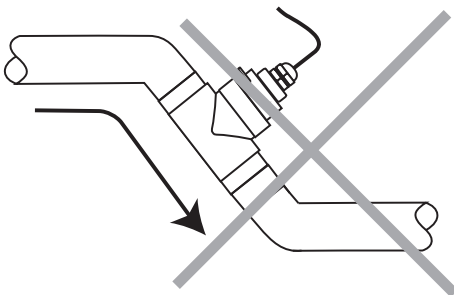

Possible Problem:
Air can be trapped

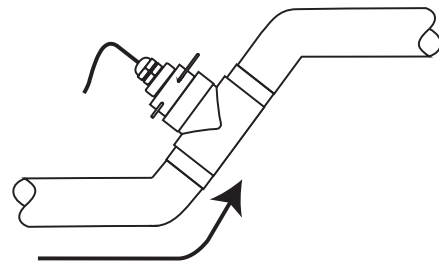

Better Installation:
Allows air to bleed off



Caution: These flow sensors are not recommended for installation downstream of the boiler feedwater pump where installation fault may expose the flow sensor to boiler pressure and temperature. Maximum recommended temperature is 130 °F (Plastic), 200 °F (Metal).

CONNECTION DIAGRAMS

All Seametric Controls (FT415/FT420/A055) (Except FT520)

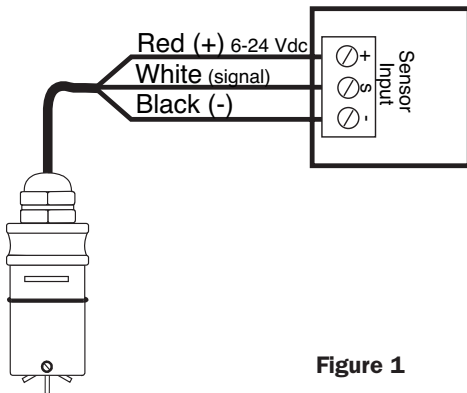

PLC's and other non Seametric Controls

Input Designed for Current Sinking (NPN) Devices

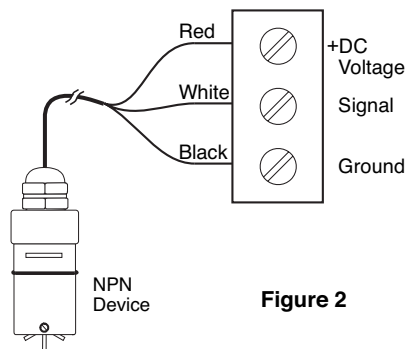

Input Designed for Current Sourcing (PNP) Devices

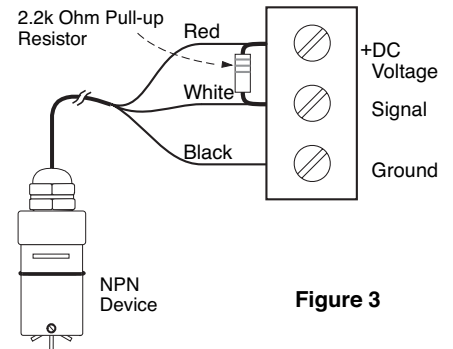

OPERATION

Minimum Flow. As with any other flow sensor, there is a rate below which the IP80-Series sensor cannot read. Check the flow rate table below for the minimum flow rate detectable by the sensor for a given pipe size.

Flow Range (GPM)

	1/2"	3/4"	1"	1-1/2"	2"	3"	4"	6"	8"
Min	0.28	0.5	0.8	1.9	3.1	6.9	12	27	46.8
Max	28	50	80	190	314	691	1190	2700	4680

Calibration ("K-factor"). The K-factor represents the number of pulses per gallon the meter produces during a flow test. This number must be entered into your electronic control to make it read properly. If the IP80-Series meter is ordered with a **tee fitting**, it is factory-calibrated in the fitting and the K-factor is indicated on the side (see below).

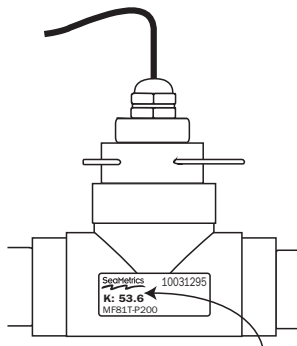



Find Your K-Factor Here

If a **saddle or weld-type fitting** has been ordered, use the K-factor calculator at the bottom of the www.seametrics.com home page to determine the K-factor. In PVC, however, it is possible to order a saddle pre-installed on a standard length of pipe, and the fitting can be wet-calibrated in this case.

Field Calibration. It is possible to field-calibrate an IP80-Series flow sensor to determine an accurate K-factor in the actual installation. The reason for doing this would be to compensate for an unusual condition, for instance, applications with higher viscosity fluid (IP meters are calibrated for water use) or which lack adequate straight pipe ahead of the meter. Field Calibration procedures are described in a Technical Bulletin on our website (www.seametrics.com).

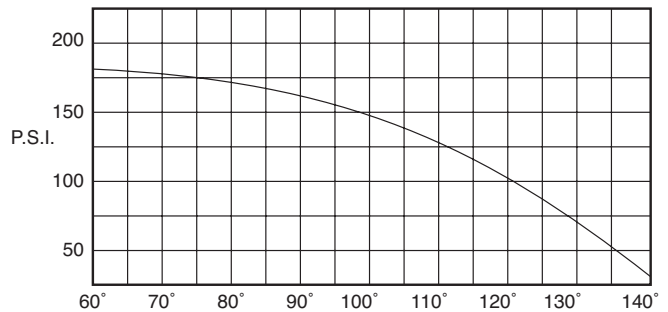
PRESSURE VS. TEMPERATURE (PVC/Polypro)





Caution: Never remove the u-clip retainer when the pipe is under pressure. Always remove pressure from the pipe before attempting to remove the meter. Removal under pressure may result in damage or serious injury.

Rotor Replacement. It is unusual for a rotor to require replacement due to damage sustained in normal service. More commonly, the meter is dropped while it is out of the pipe. Another reason for rotor replacement is shaft wear after long service. Rotors are easily field-replaced.

To install a rotor, follow these steps:

1. Unscrew the threaded bearing housings to expose the shaft ends. If bearings are being replaced, back them completely out.
 2. Remove the rotor. Put the new rotor in its place.
 3. Thread in one bearing housing part way, then the other. Take care to start the end of the shaft into the bearing hole before tightening further.
 4. Screw in bearing housings until they bottom.
- Note: Do not use excessive force.**
5. Check for free spin. Blowing lightly on the rotor should result in it spinning rapidly and coasting to a smooth stop.



Signal Troubleshooting. The flow sensor has only one moving part, the rotor. If this is turning properly and there is no signal, the magnetic sensor is not operating properly. To check the signal, apply 12 Vdc power to the red (+) and black (-) leads. Set a multimeter to voltage reading. Put the positive multimeter lead on the red wire and the negative lead on the white wire. Slowly turn the rotor. Voltage reading should swing between -12 Volts and 0 Volts as the rotor turns. If it does not, the solid-state magnetic sensor is not working properly. Checking for continuity is not a useful test of these sensors.

Sensor Replacement. It is very unusual for a sensor to require replacement in normal use. The primary cause of sensor failure is overvoltage (inadvertent connection of high voltage, for example) or incorrect polarity on hookup. The sensor is replaced by removing the strain relief, then threading out the sensor retainer plug. Remove the entire sensor capsule by pulling on the cable. The new sensor capsule can then be installed. Replace the retainer plug, and then replace and tighten the strain relief.

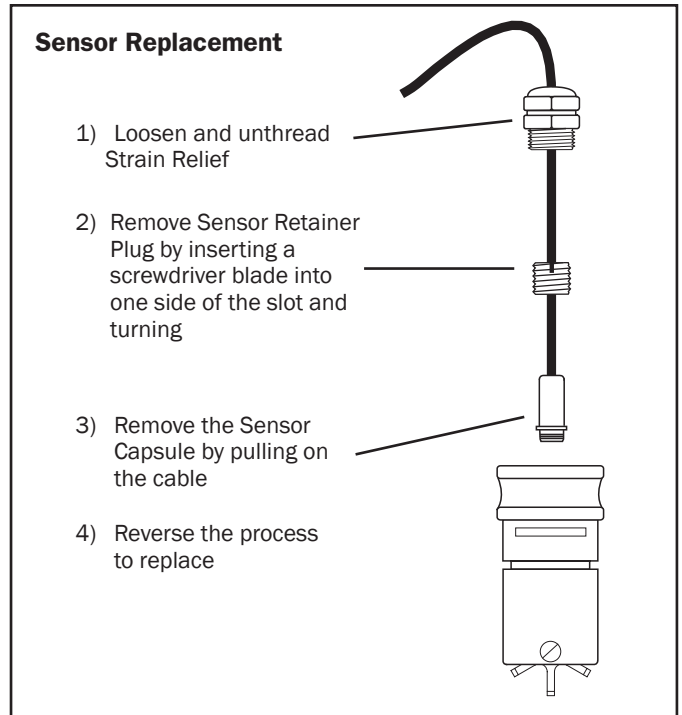

PARTS EXPLOSION

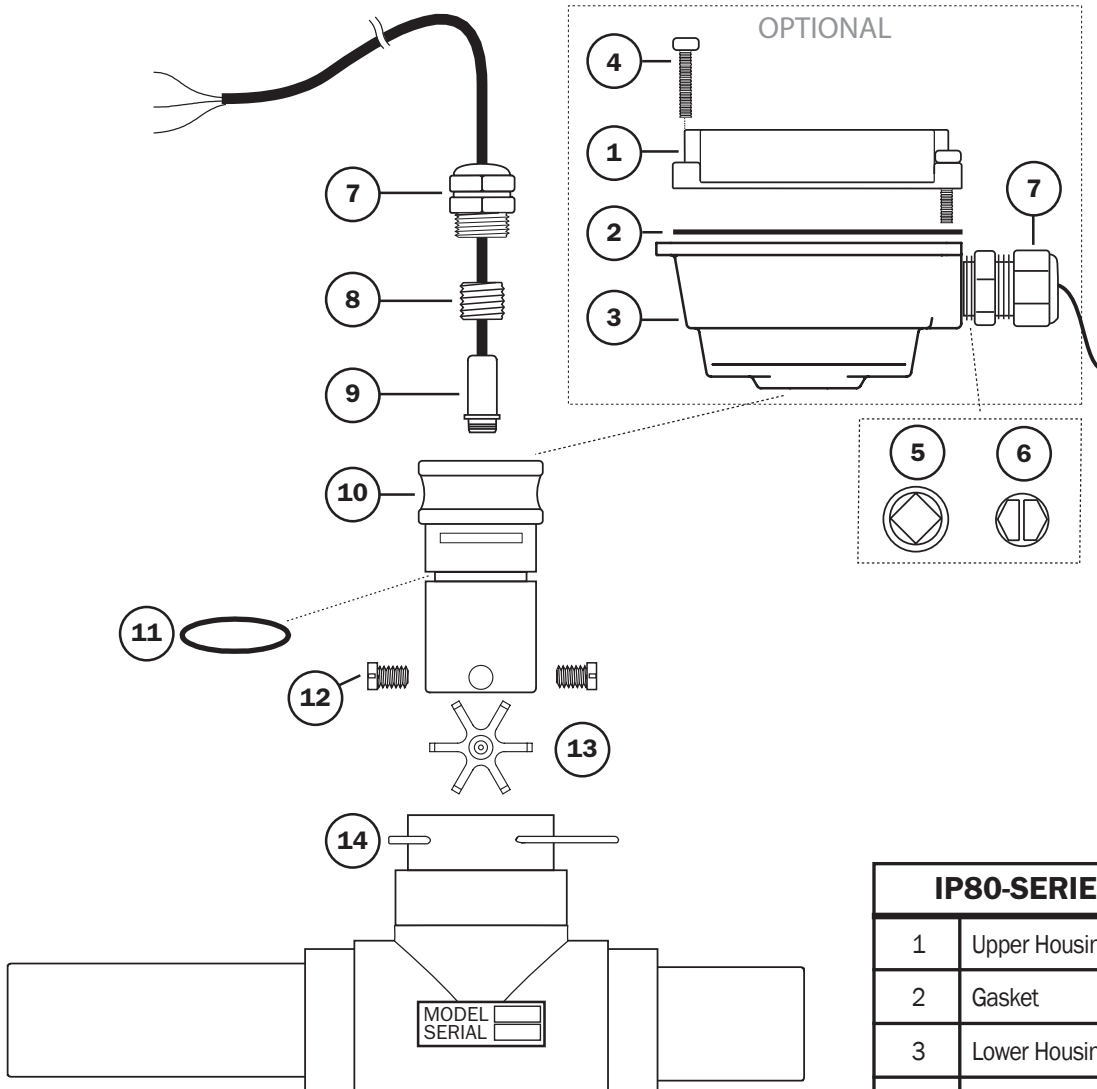

IP80-SERIES PARTS LISTING		
1	Upper Housing	26181
2	Gasket	26211
3	Lower Housing	29930
4	Housing Screw Assembly	26229
5	Plug, Steel	26073
6	Plug, Plastic	26079
7	Strain Relief	07655
8	Sensor Retainer	25321
9	Sensor, Low Power	26310
10	Body	*
11	O-Ring, EPDM	25081
12	Bearing Screws (2)	25901
13	Rotor (Nickel/Carbide Shaft) Rotor (Ceramic Shaft)	11130 11132
14	Fitting	*
12/13	Rotor Repair Kit (Kynar/Carbide) Rotor Repair Kit (Kynar/Ceramic)	25902 12131

* Consult distributor

TROUBLESHOOTING

Problem	Probable Cause	Try...
No signal after installation	Insufficient flow	Consult Flow Range Chart Reduce pipe size or use different sensor
	Bad connections to control electronics	Check connections at control; Red (+), Black (-), White (signal)
	Incompatible control	Use 6-24 Vdc power supply Add pull up resistor, if using current-sourcing device
	Damaged or missing rotor	Remove flow sensor from fitting and check for free spinning; replace rotor
	Failed magnetic sensor	See signal troubleshooting; replace magnetic sensor
Inaccurate metering	Not enough straight pipe between meter and severe flow disturbance	Move meter away from flow disturbance, or field-calibrate
	Wrong K-Factor entered	Check fitting for K-Factor, check indicator to see if it is entered properly ("Set K" on FT420, FT415, FT520)
	Magnetic sensor failing to pick up each blade	Remove flow sensor from pipe. If indicator is FT415, FT420, FT520, set K to 1.00, turn rotor slowly by hand, indicator should count each blade; replace sensor
	Wrong time units on flow indicator	If using FT415 or FT420, check left side of display (sec, min, hr, day); change to desired unit



Seametrics Incorporated • 19026 72nd Avenue South • Kent, Washington 98032 • USA
(P) 253.872.0284 • (F) 253.872.0285 • 1.800.975.8153 • www.seametrics.com

LT-65200040-D
1/19/2011