

# HOBBBS

PLFD STATION IND.

## PUD SIGNAGE PLAN

Plainfield, IN

**PROJECT**

Hobbs Station  
2870 Pearson Parkway  
Plainfield, IN 46168

**PROPERTY MANAGER**

Hobbs Station MU Multifamily QOZB LLC  
Attn: New City Development  
350 Massachusetts Ave, Suite 300  
Indianapolis, IN 46204  
Ph: 608-931-3650

**SIGNAGE CONSULTANT**

Elevated Identity  
1 Parker Place, Suite 301  
Janesville, WI 53545

Ryan Coffey  
Ph: : 602.821.8515  
ryanc@elevatedidentity.com

**PARCEL INFORMATION**

**PARCEL NUMBER:**  
32-09-19-300-022.000-027  
32-09-19-300-025.000-027  
32-09-19-300-030.000-027  
32-09-19-310-001.000-027  
32-09-19-352-001.000-027  
32-09-19-352-002.000-027  
32-09-19-376-001.000-027  
32-09-30-133-002.000-012

**PARCEL ACREAGE:**  
86.84

**ZONING:**  
PUD

**JURISDICTION:**  
Hendricks County  
Washington Township  
Town of Plainfield

**CONTENTS**

Definitions	2
Sign Criteria	3
Graphic Standards	4
Sign Location Plan	5-7
Mixed-Use Project Identification Sign	8-9
Residential Community Identification Signs	10-11
Commons Project Identification Sign	12
Mixed-Use Building & Tenant Signage	13-17
Parking Signage	18
Mixed-Use Street Signs	19
Construction/Coming Soon Signs	20
Mixed-Use Rooftop Signage	21
Mixed-Use Wayfinding Signs	22
Townhome Community Identification Signs	23
Mixed-Use Temporary & Other Signs	24

**NOTE:**

The following definitions are used throughout this Comprehensive Signage Plan (CSP), and are exclusive to this document.

**Aggregate Sign Area**

The total area of all permitted signs pertaining to any one tenant, which includes Street-front signage and storefront signage (arcade and window signage/graphics).

**Architectural Frontage**

The portion of the building frontage of the leased space which has been delineated through use of reveals, patterning, materials, finishes, column breaks, etc., that creates a special area for signage.

**Building Leased Frontage**

The overall lineal foot frontage of a leased space.

**Sign Envelope**

The overall height and length allowances for sign area designated for tenant sign placement on a building elevation.

**Street Front Signage**

Signage installed parallel to the building fascia, typically located along the front of the building on a parapet, fascia, awning or building wall intended for the viewing by vehicular traffic.

**Storefront Signage & Graphics - Permanent**

Signage located along the storefront portion, oriented to the pedestrian. It includes the transparent portion of storefront (windows) and/or solid wall areas used for merchandise display and permanent graphics. This includes awnings, tenant suite number, logo and name identification, secondary name modifiers, hours of operation, services or name brand marketing, menu cabinets, etc

**Storefront Signage & Graphics - Temporary**

Any sign, banner, pennant, valance or advertising display constructed of vinyl, cloth, canvas, light fabric, cardboard, wallboard or other like material, with or without frames.

**Architectural Awnings**

Elements which are constructed of permanent type of materials and are an integral part of the building elevation design.

**Custom Cabinet**

Metal box-like structure that is internally illuminated, with multiple surface planes, colors, finishes and unique shapes and forms. Typically includes dimensional illuminated letters and opaque backgrounds.

**Graphics**

Lettering, symbols, and logos used for name identification (primary identification), and for identification of product and services (secondary identification or modifiers).

**Sign Band**

A physical architectural feature on a building surface, often above building entrances, designed to accommodate wall signage.

**Sign Envelope**

A designated area on a building elevation that defines the outermost reaches that a sign can occupy. The area of a sign envelope is usually determined by ascribing a percentage of available horizontal and vertical wall space to be the sign envelope. A sign envelope does not necessarily define the allowable sign area for a sign. A sign envelope can be located within a sign band.

**Sign Area**

The area of a sign structure in which copy and graphics may be placed. Sign area shall be computed by surrounding each graphic element with a rectangle calculating the area.

**Marquee/ Vertical Blade Sign**

A permanent sign structure in a vertical format attached to and supported by the building and projecting over public walkways. A vertical marquee is completely supported by the building and has no support poles or columns that extend down to the ground.

**Canopy**

An overhanging structure affixed to a wall, or superimposed upon any roof like structure, and extending over a sidewalk, walkway, or vehicle access area.

**Rooftop Sign or Rooftop Scaffold Sign**

A building-mounted sign erected upon and completely over the roof of the building, usually with braced metal framing.

**Roofline Sign**

A building-mounted sign erected on top of, affixed to, or incorporated into the top surface of the roofline edge. These signs will always have a Raceway (or Wireway) connecting them to the rooftop.

**Raceway or Wireway**

A Raceway is a rectangular sign mounting structure that also serves as an enclosure for both signage electrical components (such as transformers) and wiring. A Wireway is similar to a Raceway, though it usually is a slimmer aluminum enclosure and mounting structure. Wireways also typically do not contain electrical components.

All signs within Hobbs Station must be compatible with the standards outlined in these CSP Standards. The purpose of the sign standards is to ensure an attractive environment and to protect the interests of the surrounding neighborhood, owner, and tenants of all buildings within Hobbs Station. Conformance will be strictly enforced, and any installed non-conforming or unapproved signs will be brought into conformance at the sole expense of the tenant. Before designing signs, all tenants will receive a copy of these signage standards. Sign plans submitted to the owner's representative for approval must conform to these standards. The owner's representative may administer and interpret the criteria as it applies to signage designs. All signs must be approved in writing by the owner's representative prior to application to Town of Plainfield, for permitting.

This criterion is intended as a guideline for all signage for all buildings in Hobbs Station development. The Tenant's sign(s) shall be limited to the Tenant's approved name as stated in the Lease or as otherwise approved in writing by Landlord. The use of a corporate logo or other established corporate insignia is permitted only if specifically approved in writing by the Landlord. Taglines or identifications of specific products or services are permitted only if specifically approved in writing by the Landlord. All signage will conform to the Comprehensive Sign Plan, placement, location, area, etc.

For owner's representative review, send signage drawings to:

Hobbs Station MU Multifamily QOZB, LLC  
Attn: New City Development  
350 Massachusetts Ave, Suite 300  
Indianapolis, IN 46204  
PH: 608-931-3650

## Signage Proposal

Each tenant must submit to the owner's representative three (3) sets of detailed shop drawings (or a PDF Electronic Copy) showing locations (on buildings and/or property), dimensions, sizes, design, colors, materials, lettering, graphics, conduits, junction boxes, sleeves, and other mounting apparatus of all proposed freestanding, wall, window, and rear door signs. This submittal must be made at least fifteen (15) days prior to submitting requests for permits or manufacturing.

## Sign Contractor's Responsibilities

Prior to preparation of signage drawings and specifications, the tenant's sign contractor must review all architectural, structural, and electrical documents as they relate to the building wall and/or storefront at the proposed signage location. In addition, the sign contractor should visit the project site to become familiar with as-built conditions and to verify all dimensions.

## Sign Shop Drawings

Sign shop drawings submitted by the Tenant shall provide complete information for the Landlord to understand the signage design, installation and appearance. Sign shop drawings shall:

- 1) provide an elevation, in scale, of the storefront façade illustrating each sign's location and size.
- 2) provide a section or sections through the sign.
- 3) identify the materials and construction.
- 4) provide complete information on installation.
- 5) provide electrical specifications for signage.

## Tenant Responsibilities For Other Regulations

The owner's representative's approval of a tenant's signage plan does not constitute an implication, representation, or certification by the owner's representative that those plans are in compliance with applicable statutes, codes, ordinances, or other regulations. Compliance with other regulations is the sole responsibility of the tenant for all work performed on the premises by, or for the tenant.

## Owner's Representative Review

After review of the signage proposal, the owner's representative will return one of the three sets of drawings (or a PDF Copy) to the Tenant, marked either "Approved," "Approved as Noted," or "Revise and Resubmit."

### "Approved"

If drawings are marked "Approved," the Tenant is allowed to proceed with sign permitting. Upon permit approval, construction and installation in accordance with the drawings may commence.

### "Approved as Noted"

If drawings are marked "Approved as Noted," the tenant is allowed to proceed with sign permitting and then construction and installation, provided that any modifications noted are incorporated into the design. An applicant that takes exception to the noted modifications may revise and resubmit, as explained below.

### "Revise and Resubmit"

If drawings are marked "Revise and Resubmit," the plans will be returned to the tenant with comments. The drawings must be revised and resubmitted for owner's representative approval.

BRANDING



PRIMARY LOGO



SECONDARY LOGOS



MONOGRAM



SWITCH GLYPH

TYPE FAMILIES

TURNPIKE

A B C D E F G H I J K L M N O P Q R S T U V W X Y Z  
 A B C D E F G H I J K L M N O P Q R S T U V W X Y Z  
 1 2 3 4 5 6 7 8 9 0  
 . , : ; ? ! \$ % & # @ \* ' " < > ( ) { }

DECOUR BOLD

A B C D E F G H I J K L M N O P Q R S T U V W X Y Z  
 a b c d e f g h i j k l m n o p q r s t u v w x y z  
 1 2 3 4 5 6 7 8 9 0  
 . , : ; ? ! \$ % & # @ \* ' " < > ( ) { }

DECOUR REGULAR

A B C D E F G H I J K L M N O P Q R S T U V W X Y Z  
 a b c d e f g h i j k l m n o p q r s t u v w x y z  
 1 2 3 4 5 6 7 8 9 0  
 . , : ; ? ! \$ % & # @ \* ' " < > ( ) { }

MATERIALS, COLORS, & FINISHES

COLORS



PMS: 412c Brown  
 CMYK: 61/66/66/62  
 HEX: 3A2EBA



PMS: 468c Cream  
 CMYK: 9/15/35/0  
 HEX: E6D1AC



PMS: 1525c Red  
 CMYK: 26/80/100/20  
 HEX: 9F4823



PMS: 7731c Green  
 CMYK: 85/24/93/9  
 HEX: 1D8649



PMS: Warm Gray 1c  
 CMYK: 13/13/20/0  
 HEX: DDD5C7



PMS: 129c Yellow  
 CMYK: 16/29/87/0  
 HEX: D9B143



PMS: 7545C Blue  
 CMYK: 79/56/47/27  
 HEX: 3B5662



Satin White Paint  
 Matthews Paint  
 Verizon White (MP 27386)



Satin Black Paint  
 Matthews Paint  
 Anodic Black (MP 41335SP)



Satin Silver Paint  
 Matthews Paint  
 Brushed Aluminum (MP 41342SP)

SPECIALTY MATERIALS



Corten Steel (Weathered)

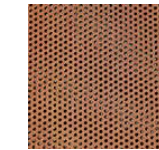

Perforated Corten Steel



Board-Formed Concrete



Cold Rolled Steel  
 Black Patina Finish



P95 Frosted Acrylic  
 3M Dusted Crystal

USAGE NOTES

Materials shown under header "Materials, Colors & Finishes" is not an exhaustive list of all materials used to fabricate Hobbs Station signage, but rather is a listing of specialty materials that are commonly used as exterior finishes or veneers. Other materials such as steel, aluminum, acrylic and polycarbonate are also commonly used in the construction of Hobbs Station signs.

The Type Families exhibited on this page shall hereinafter be referred to as the "Project Fonts". The Project Fonts apply to community identification and direction. Titles, Headers, Place Names and Directions that pertain to the Hobbs Station development shall utilize the Project Fonts. Tenant signage is not confined to the Project Fonts. With Landlord approval, Tenant Names and Logos may utilize corporate colors, fonts, logos and logotypes.



- 1 Mixed-Use Project Identification
- 2 Residential Community Identification
- 3 Commons Project Identification
- 4 Mixed-Use Building & Tenant Signs
- 5 Parking Signage
- 6 Street Signs
- 7 Mixed-Use Wayfinding Signs
- 8 Mixed-Use Rooftop Signs
- 9 Townhome Community Identification



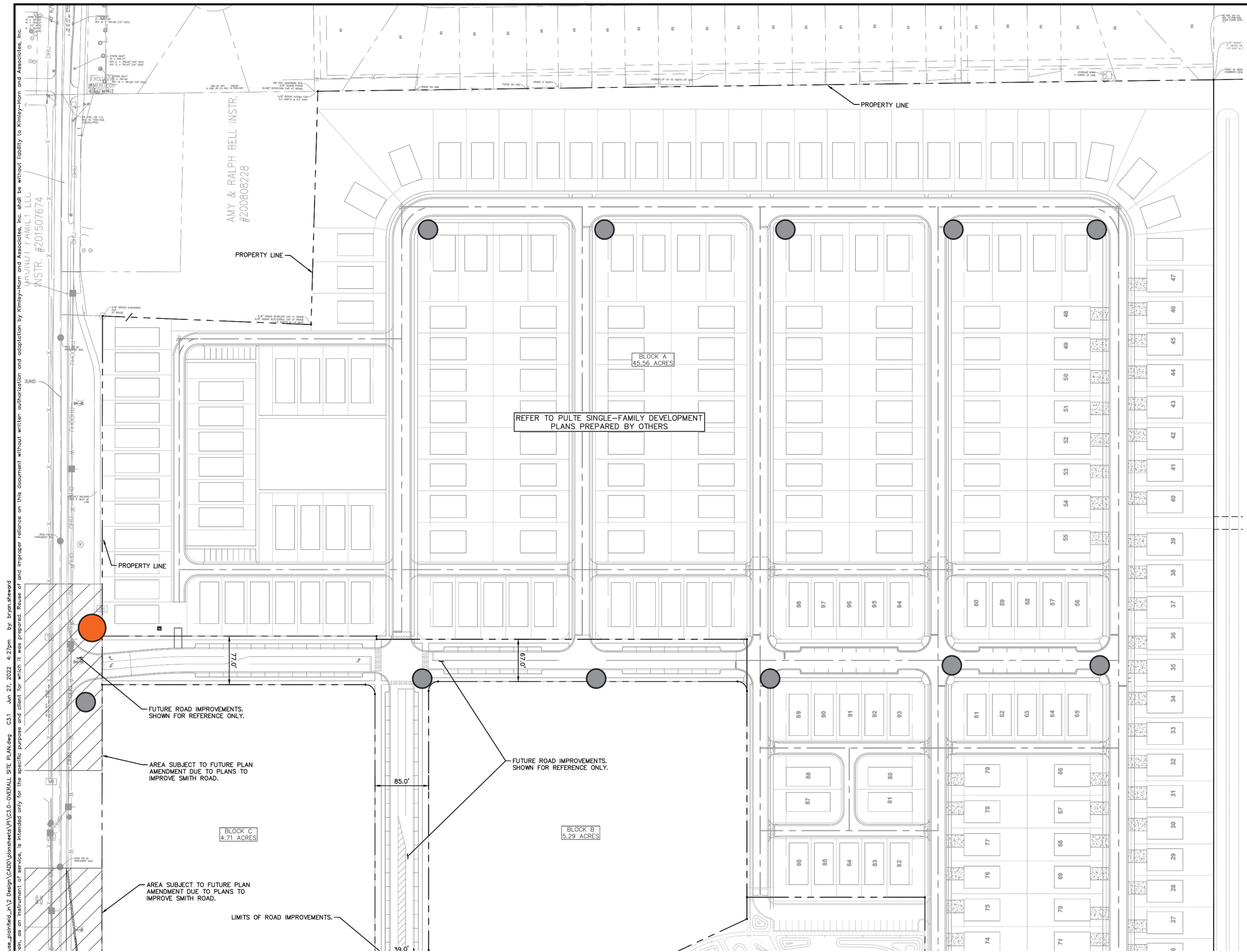



POTENTIAL EXAMPLES,  
FINAL SIGN WILL BE  
ADJUSTED AND SUBMITTED  
FOR APPROVAL.

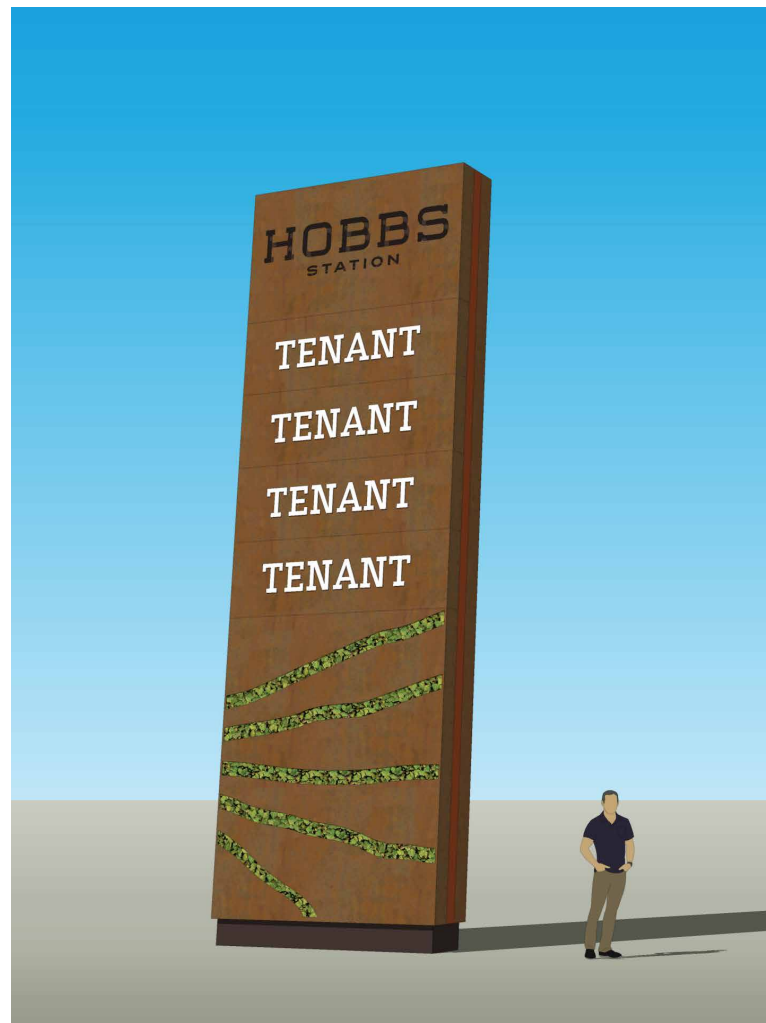

POTENTIAL EXAMPLES,  
FINAL SIGN WILL BE  
ADJUSTED AND SUBMITTED  
FOR APPROVAL.

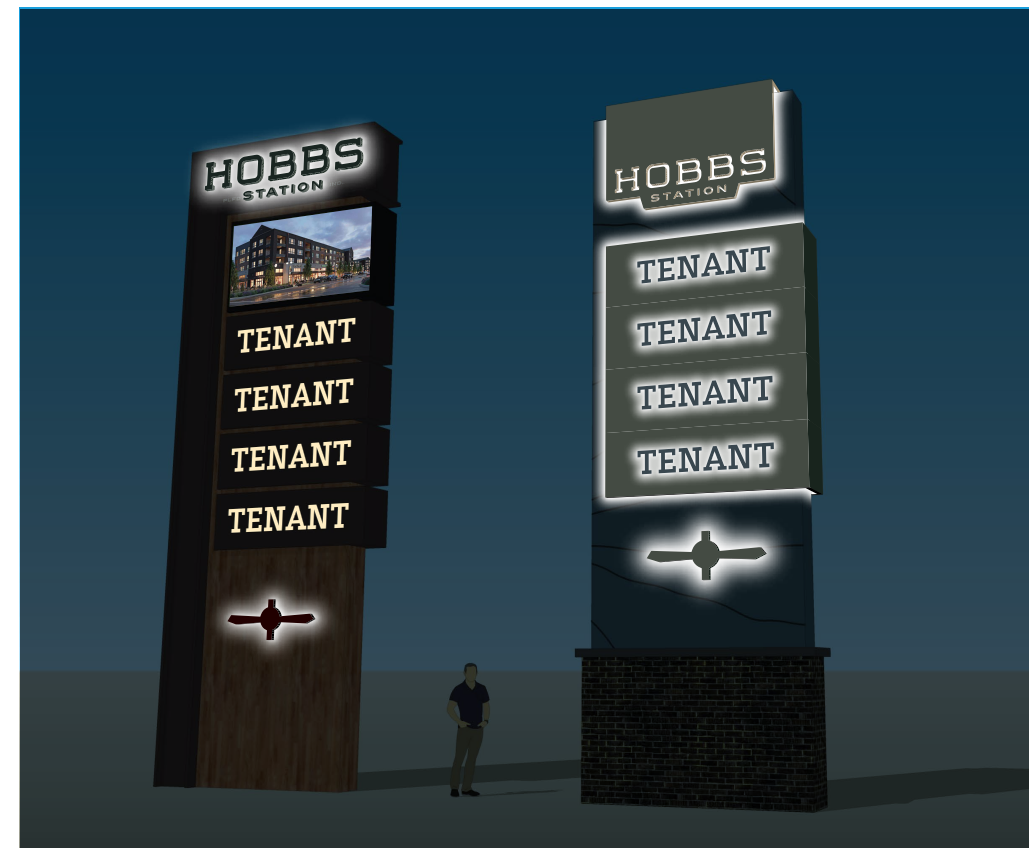
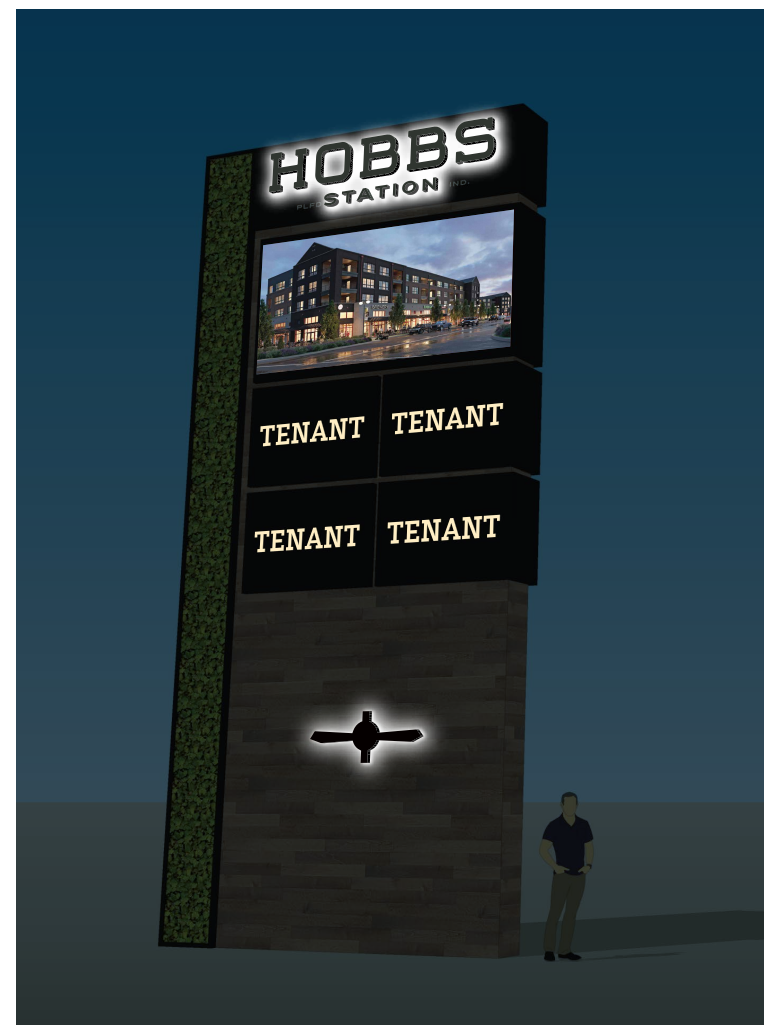

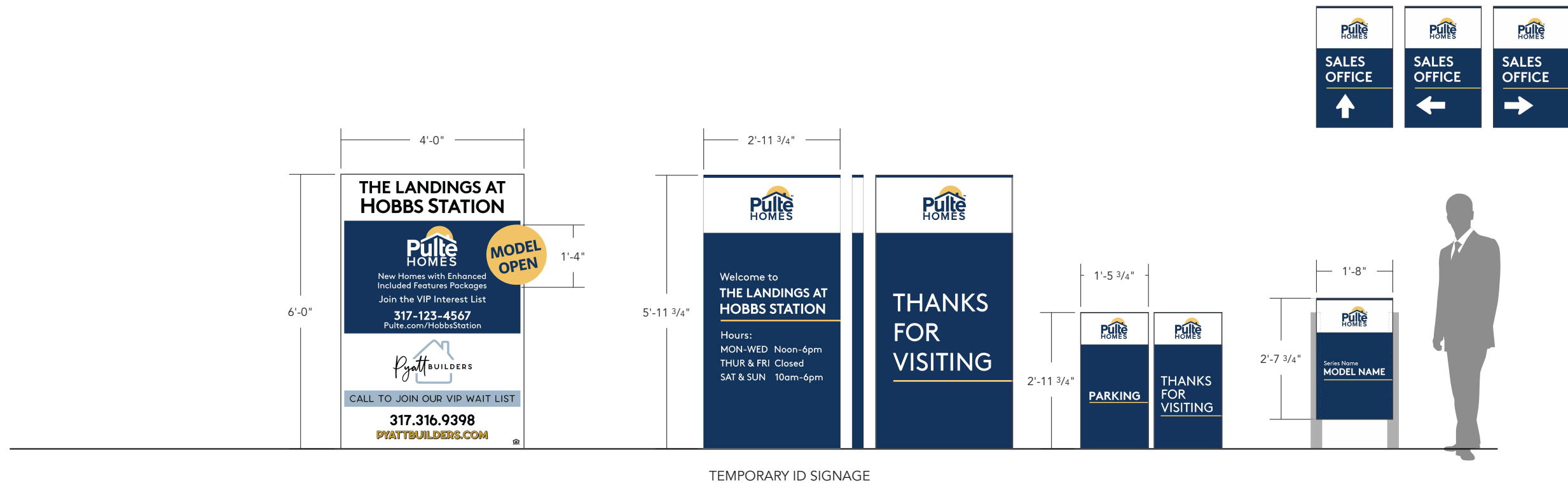

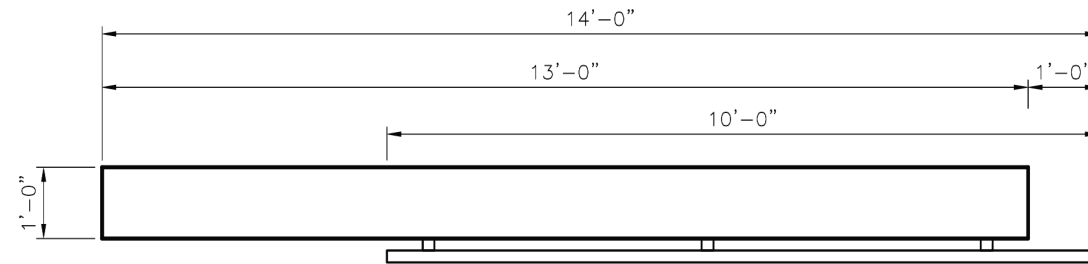

ENTRY MONUMENT: PLAN VIEW

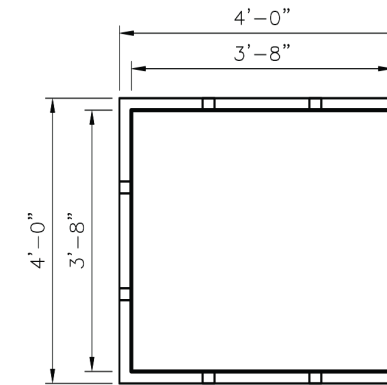

ACCENT COLUMN: PLAN VIEW

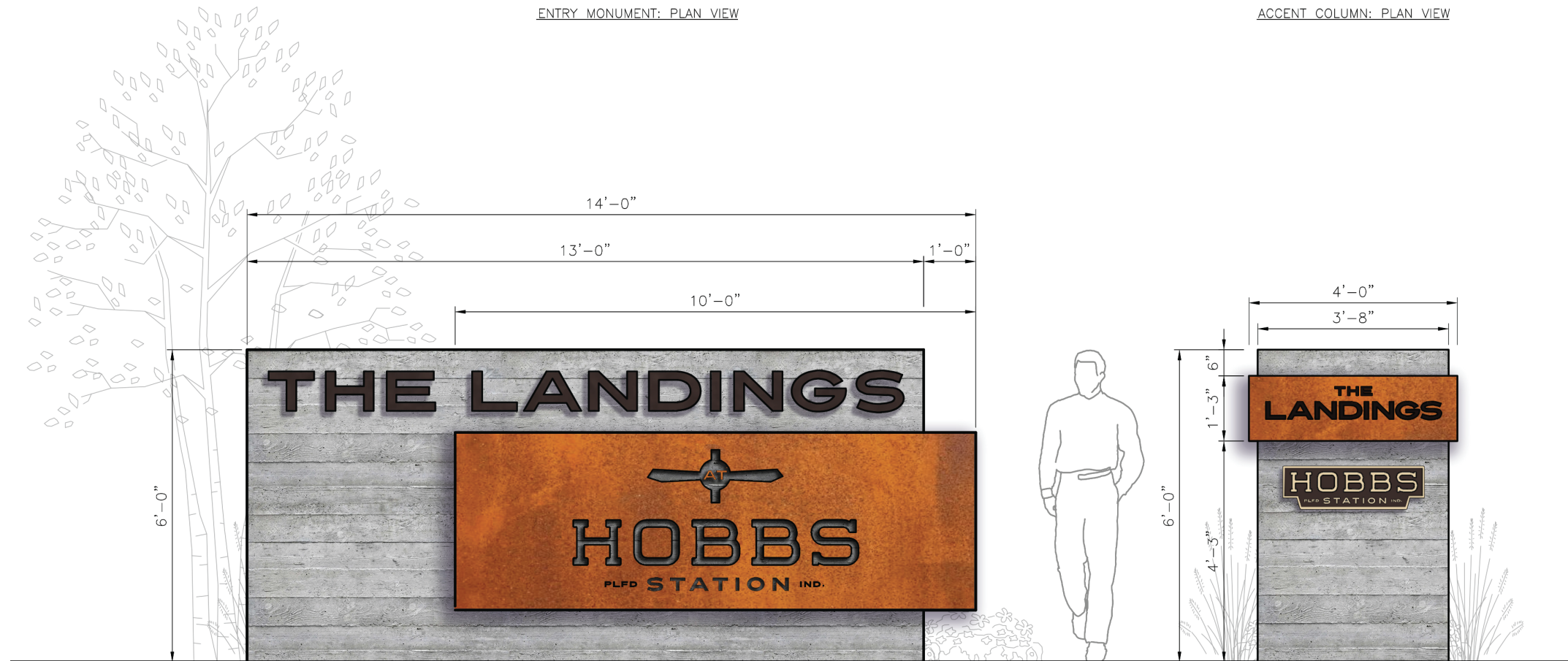

ENTRY MONUMENT: FRONT ELEVATION

ACCENT COLUMN: ELEVATION (ALL SIDES)





## TYPICAL SIZE & LOCATION

Identification for all applications shall be centered within the designated architectural sign areas (sign envelope, red box) in the proportions of 80% of the horizontal dimension, and 80% of the vertical dimension (yellow box).

Tenants may not exceed beyond 80% of the horizontal dimension, and 80% of vertical dimension of the sign envelope.

- Architectural Sign Area
- Available Signage Area

80% Height & Width



**PAN CHANNEL LETTERS**  
FACE ILLUMINATED • FLUSH MOUNT

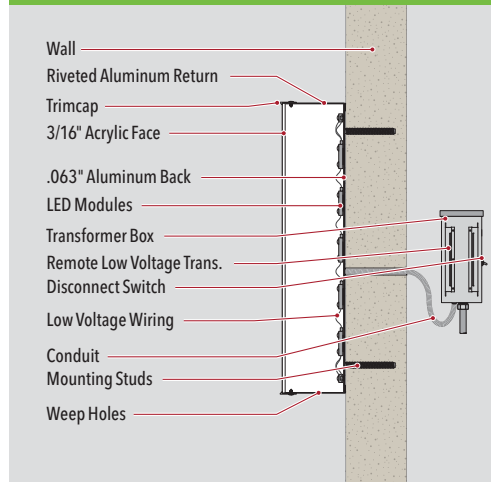

**PAN CHANNEL LETTERS**  
FACE ILLUMINATED • RACEWAY w/ BACKER PANEL

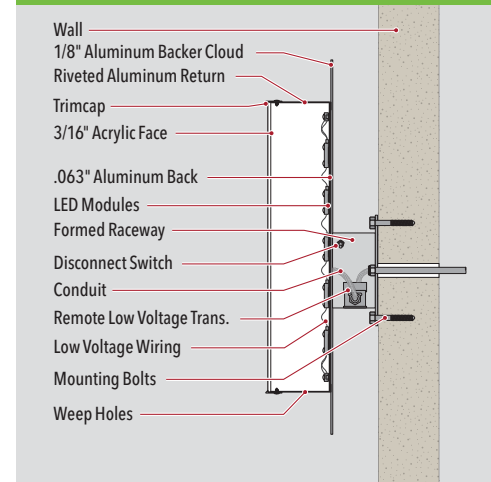

**PAN CHANNEL LETTERS**  
FACE ILLUMINATED • RACEWAY MOUNT

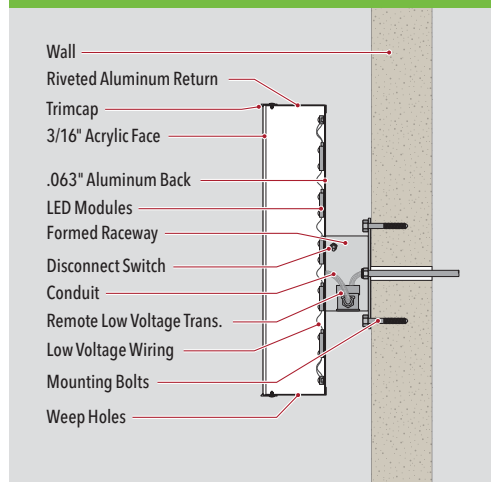

**PAN CHANNEL LETTERS**  
FACE ILLUMINATED • BACKER PAN

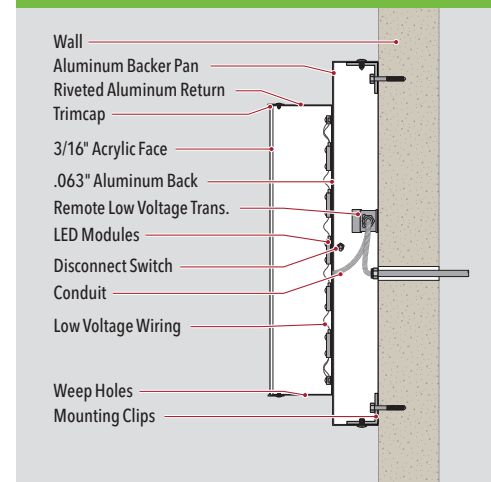

**REVERSE PAN CHANNEL LETTERS**  
HALO ILLUMINATED • STAND-OFF 1 1/2"

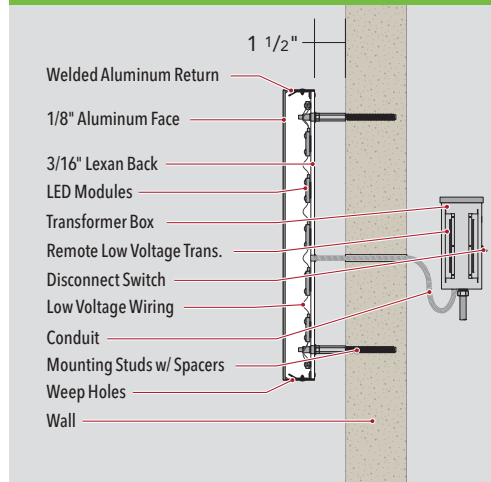

**REVERSE PAN CHANNEL LETTERS**  
HALO ILLUMINATED • BACKER PANEL & RACEWAY

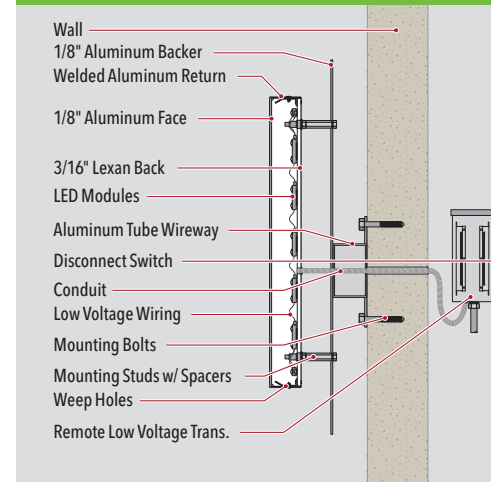

**PAN CHANNEL LETTERS**  
FACE & HALO ILLUMINATED • STAND-OFF 1 1/2"

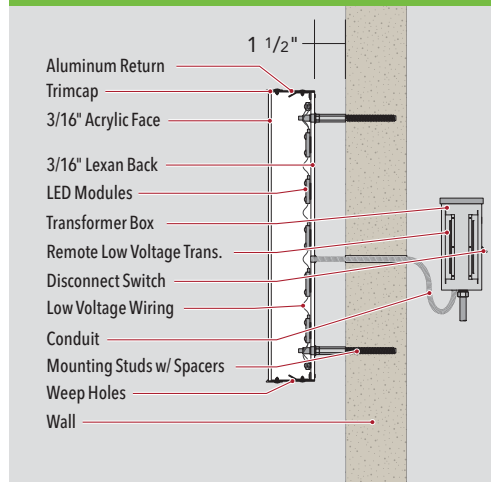

**REVERSE PAN CHANNEL LETTERS**  
HALO ILLUMINATED • BACKER PAN MOUNT

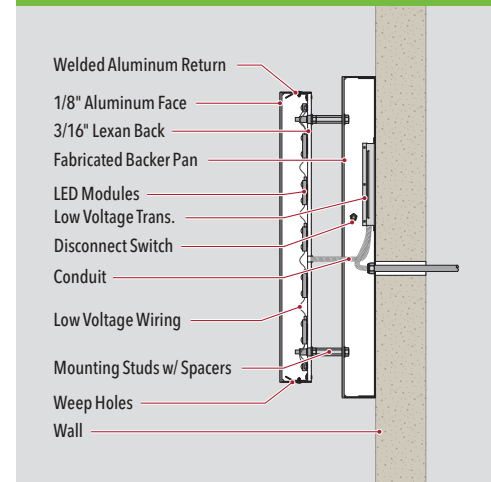

**REVERSE PAN CHANNEL LETTERS**  
NON-ILLUMINATED • FLUSH MOUNT

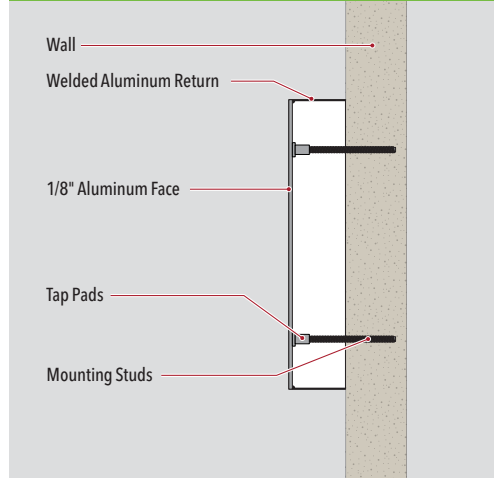

**REVERSE PAN CHANNEL LETTERS**  
NON-ILLUMINATED • STAND-OFF

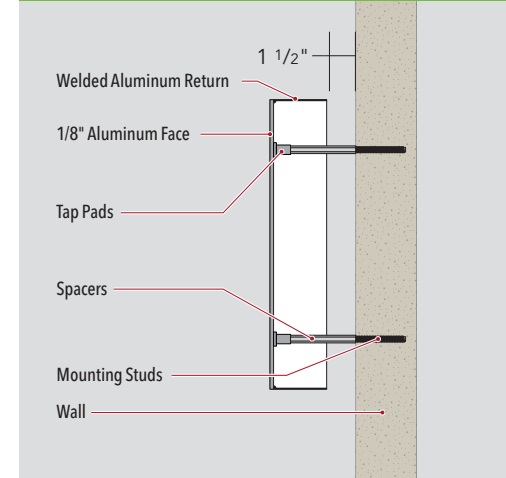

**FLAT CUT-OUT LETTERS**  
NON-ILLUMINATED • FLUSH MOUNT

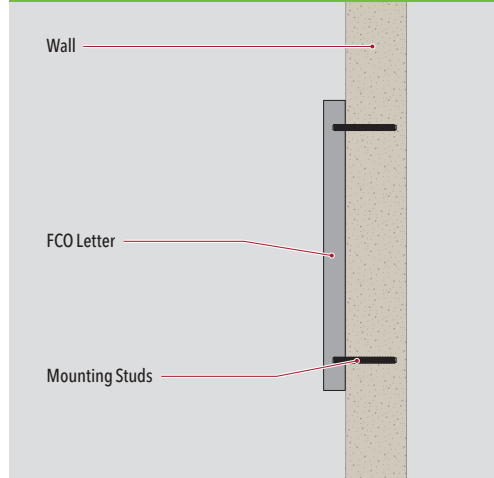

**FREESTANDING MONUMENT**  
NON-ILLUMINATED • DOUBLE-FACED

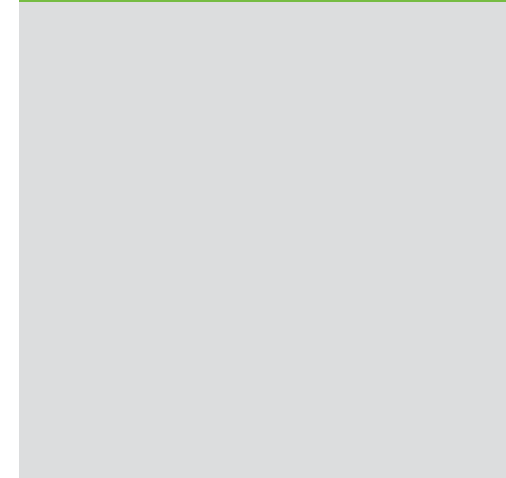

**TYPICAL SIZE & LOCATION**

A projecting blade sign shall be a sign attached to a building or other structure and extending perpendicular from the structure.

The projecting blade sign must be at least eight (8) feet above any walkway surfaces and not installed above twenty (20) feet from Finished Grade. Maximum projection shall not exceed four (4) feet. Mounting brackets must be decorative elements, compatible with the architecture of the base building. A projecting blade sign may be up to 10 sq. ft. as calculated from one side of the sign, & may be up to 12" in total depth or thickness as measured between the outmost surfaces on each side of the sign.

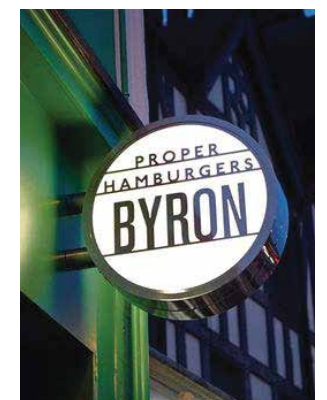
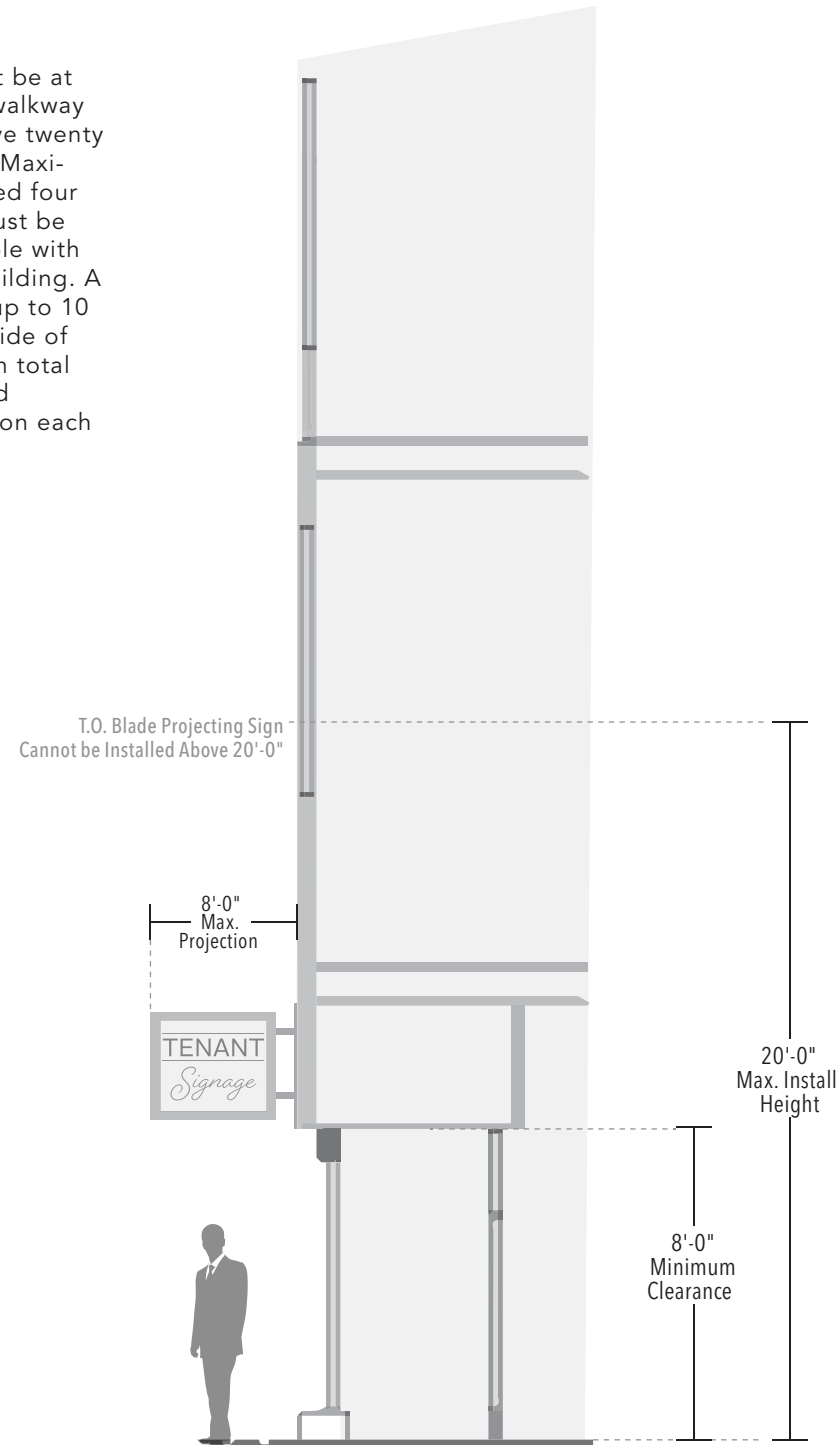

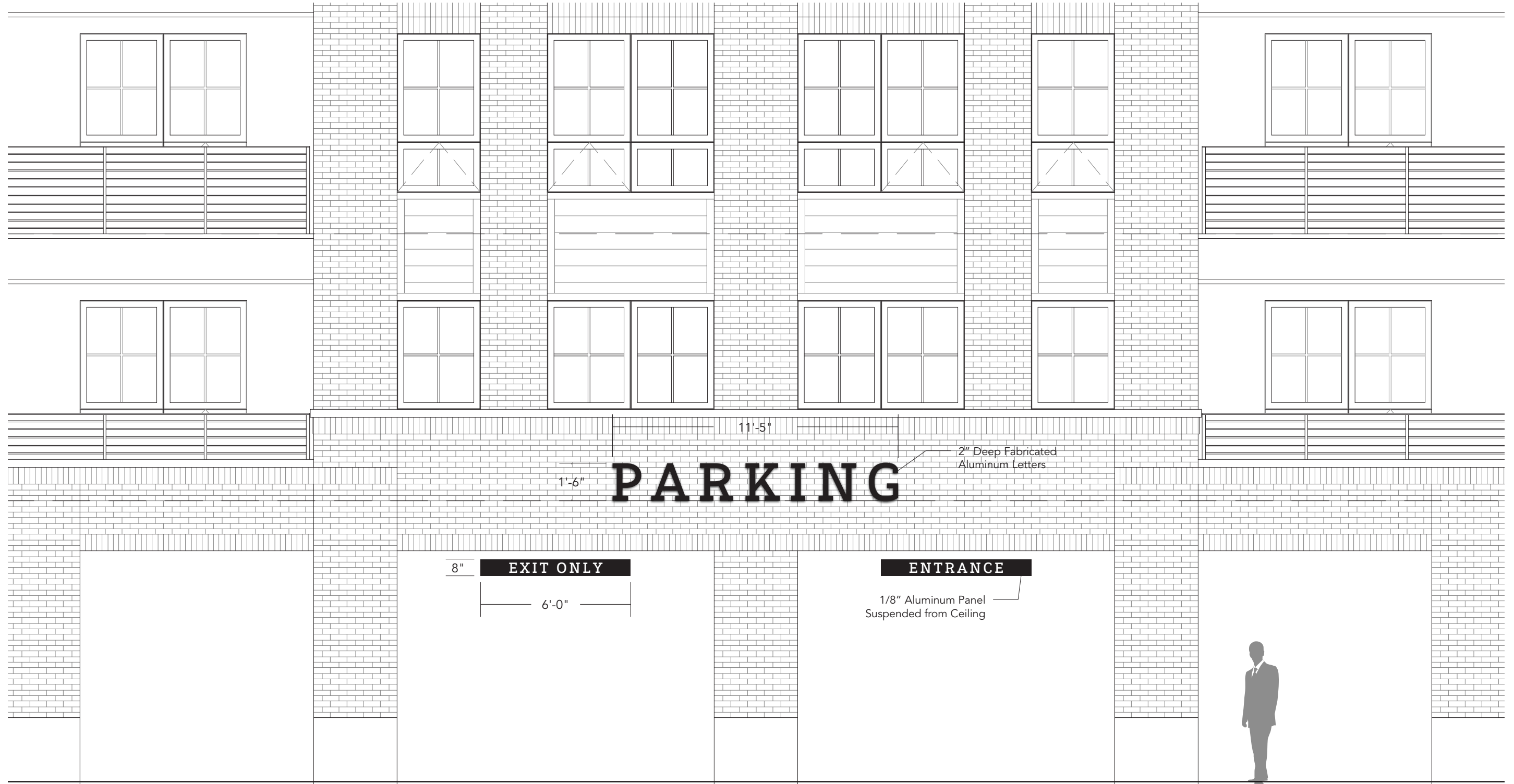

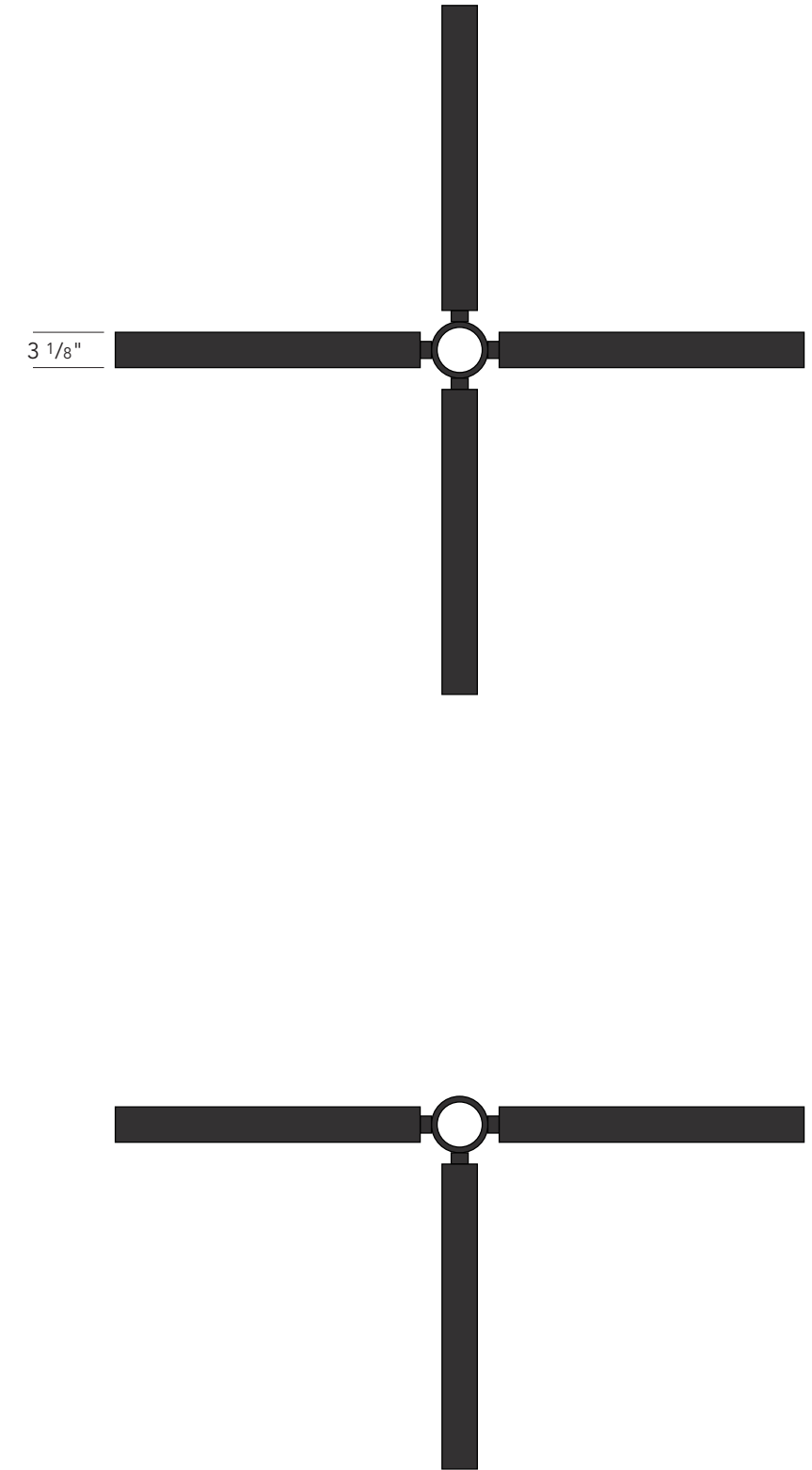
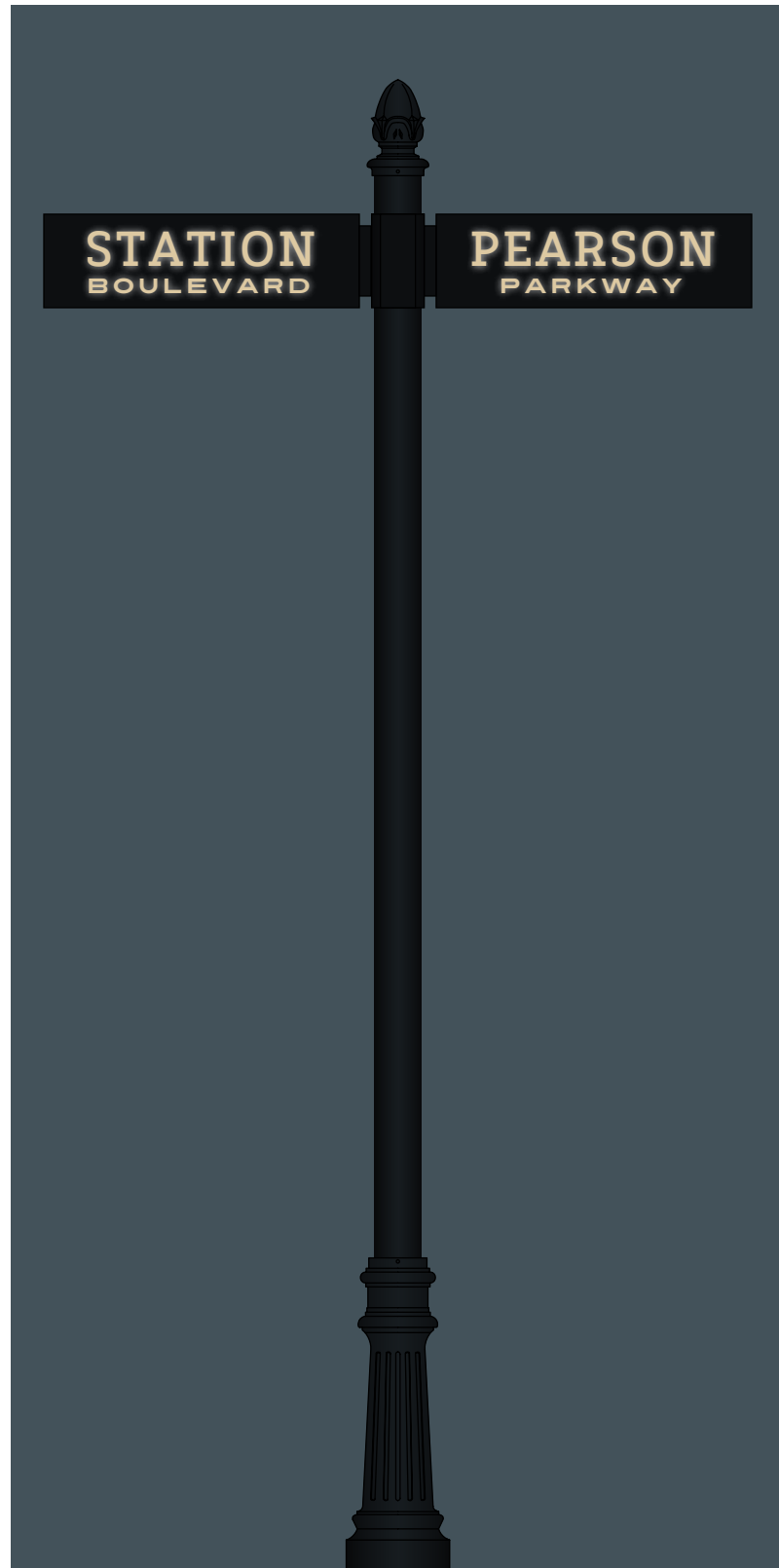
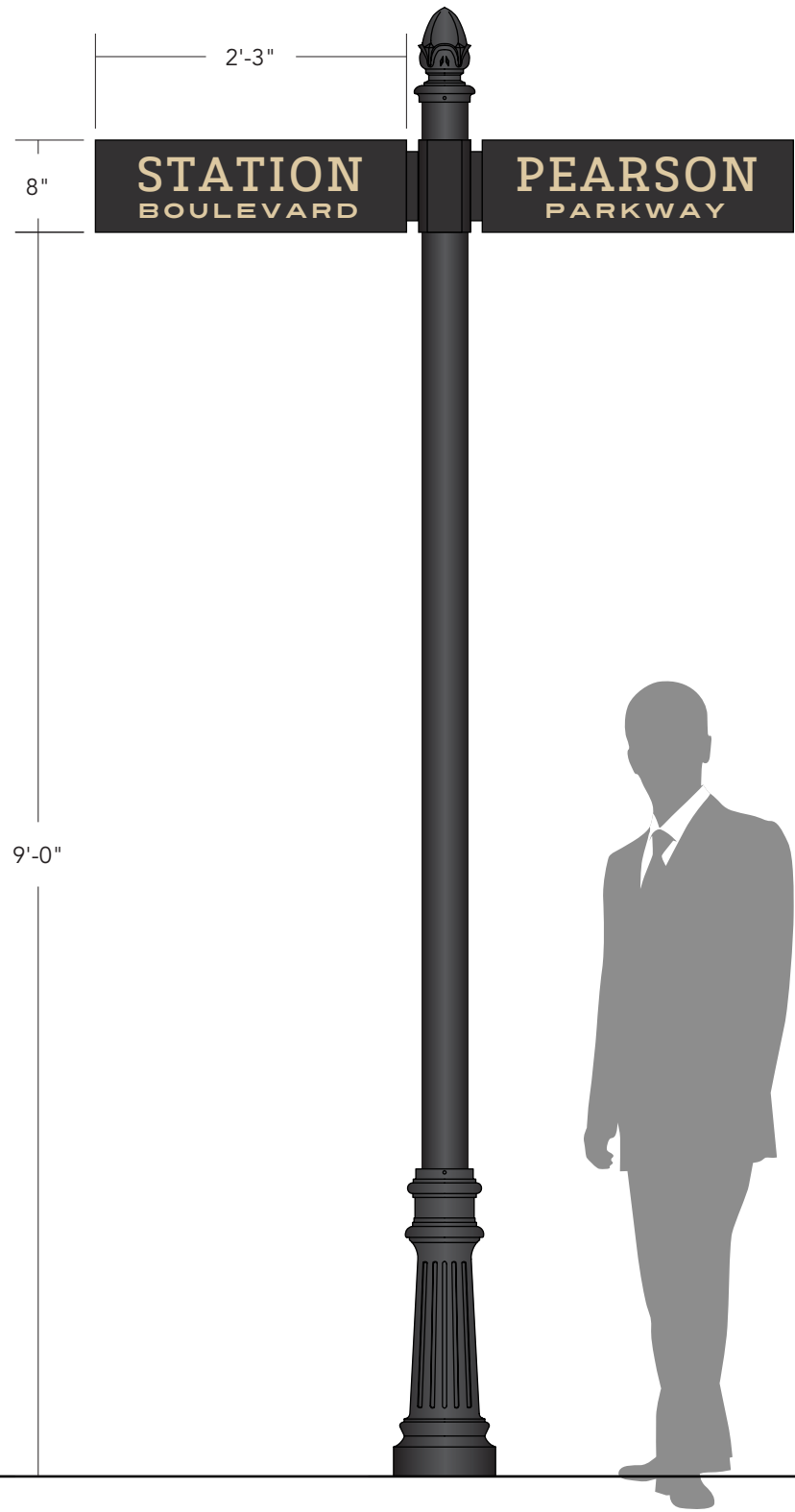

TEMPORARY CONSTRUCTION SIGNS

Temporary construction signage shall be permitted. The signage shall be placed around any construction fencing and can feature logos for parties involved with the project as well as images associated with the project itself. Upon construction completion, the signage shall be removed.

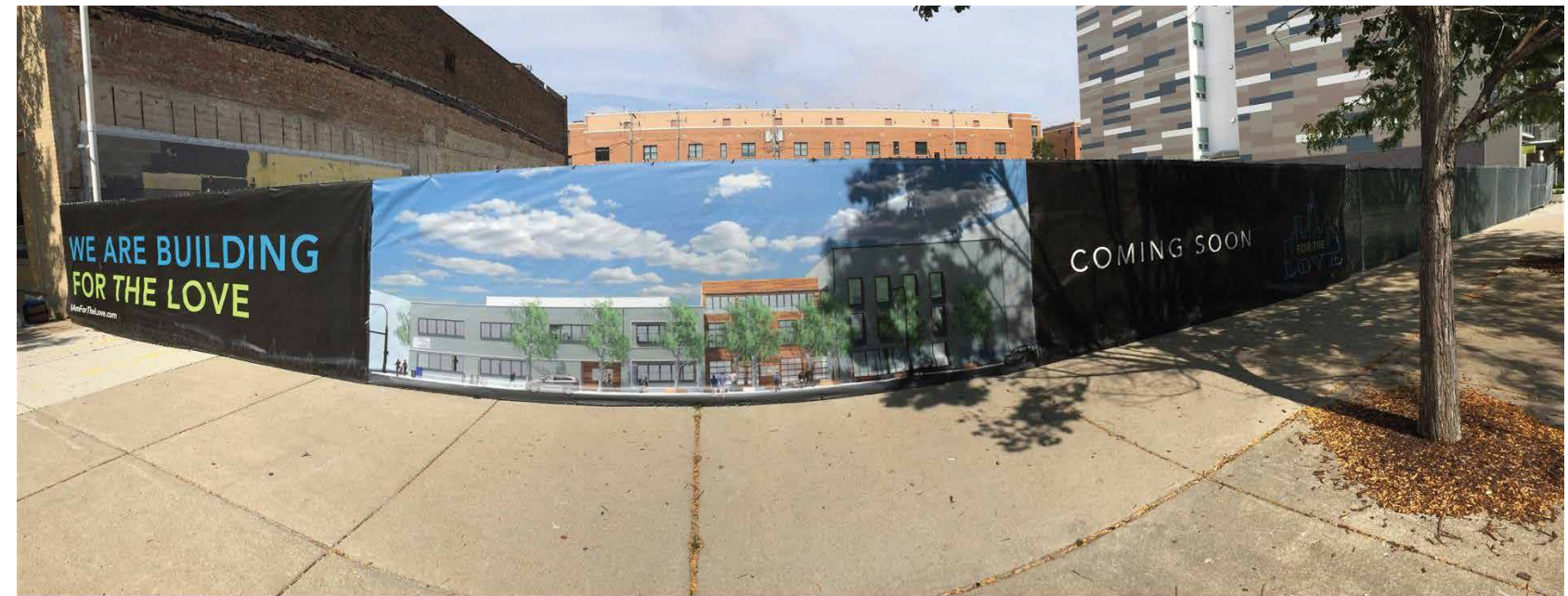

## ROOFLINE SIGNS

A Roofline Sign is a sign placed on top of, affixed to, or incorporated onto the top surface of a roofline edge. Signage will be mounted to a Raceway attached to the rooftop. The letters may be mounted to the face or top of the Raceway. These are special signs and can only be installed with approval of the Landlord. Neon Illumination may be used with approval of the Landlord. Sign bands allowed for this sign type are marked as such in this document.

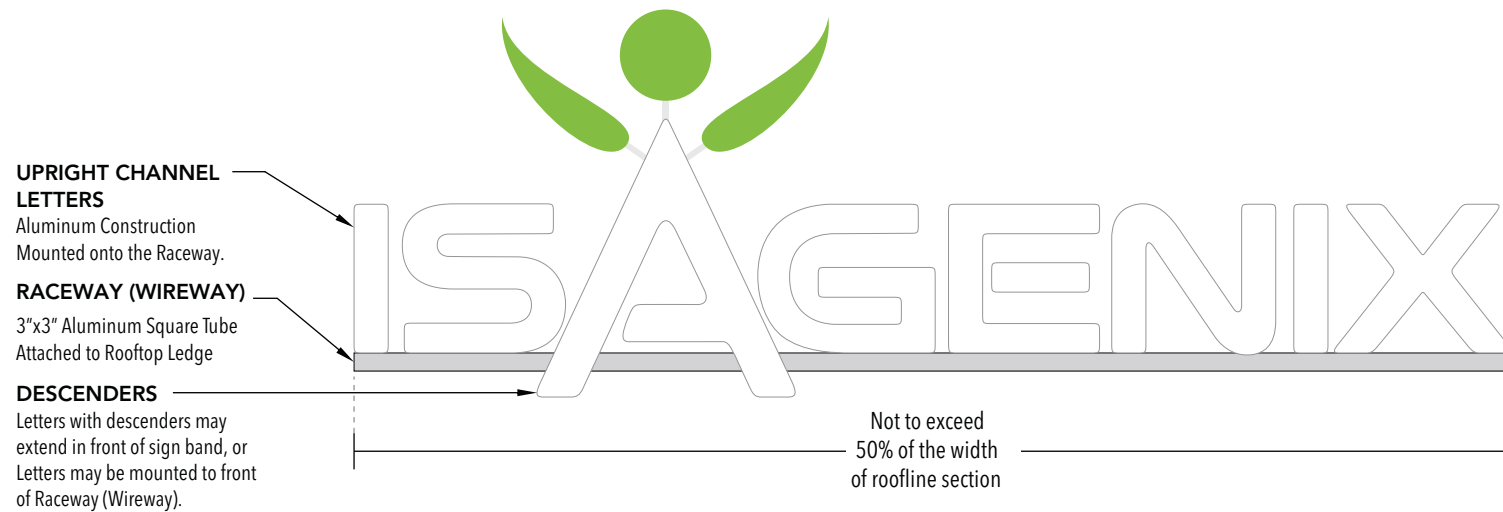

### OPTION 1

Face Illuminated Pan Channel Letters Upright Mounted on Sign Band

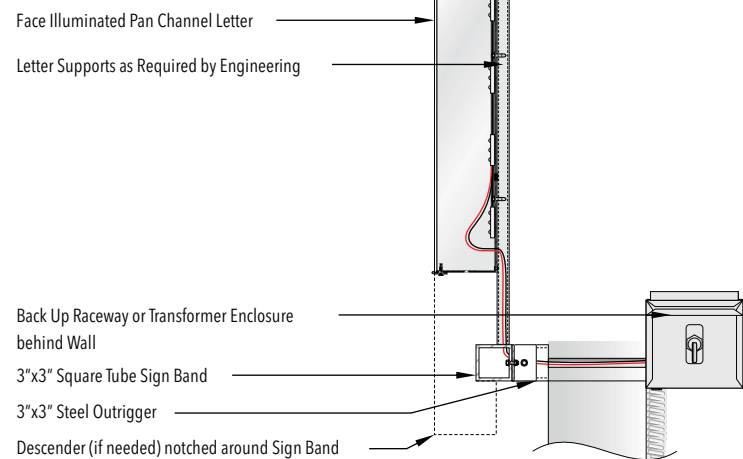

### OPTION 2

Halo Illuminated Reverse Pan Channel Letters with Backer Panel Upright Mounted on Sign Band

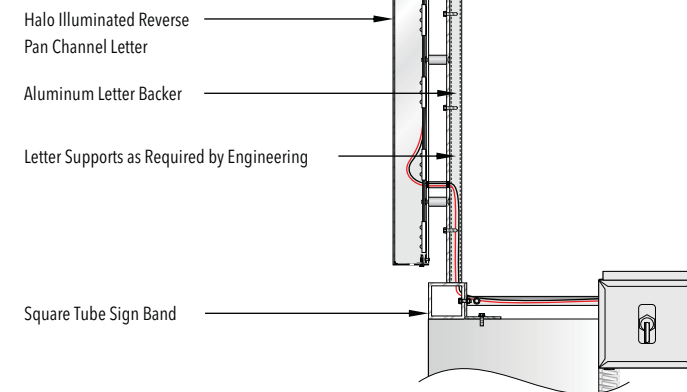

### OPTION 3

Face Illuminated Pan Channel Letters Secured to Sign Band; Suspended Over Rooftop Edge

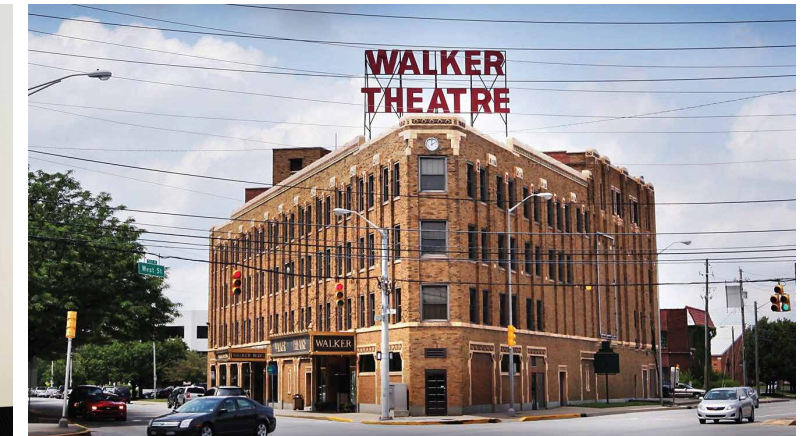
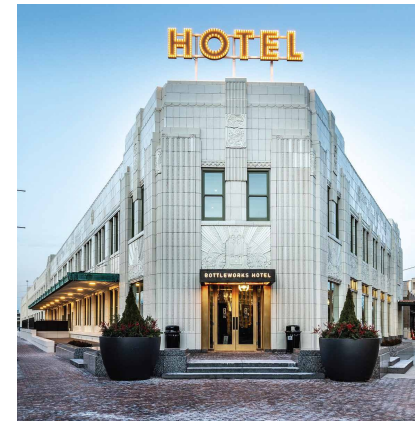
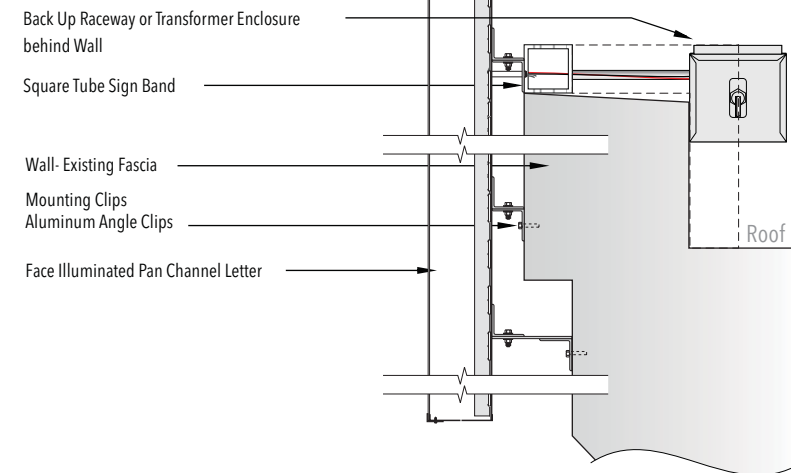

EXAMPLE UPRIGHT MOUNTED SIGNS

PARKING WAYFINDING

TRAIL WAYFINDING





TEMPORARY RETAIL / PORTABLE SIGNS

A temporary retail or portable sign is any sign or advertising device not secured in place, such as an A-frame or spring-loaded sign. A temporary retail or portable sign is a sign either portable or stationary used to display information relating to a land use or event of limited duration which is intended to be removed upon termination of said land use or event. Temporary retail and portable signs shall not count against the maximum sign area, height or quantity allowed. One (1) temporary retail or portable sign shall be permitted for and at each entry point. The maximum sign area for temporary retail or portable sign shall be sixteen (16) square feet. Maximum sign height shall not be regulated, but the signs taller than three and a half (3.5) feet must be designed so they do not endanger pedestrians or vehicles by falling over. Temporary retail or portable signs must be decorative elements, compatible with the architecture of the base building, the tenants storefront, or the setting they will be placed in. Temporary retail or portable signs are not permitted to block building entrances or sidewalk clear routes. Permits for temporary retail or portable sign must include the locations where they may be set up.



EXAMPLE TEMPORARY RETAIL / PORTABLE SIGNS

WINDOW SIGNS

Window signs or applied graphics shall be any sign placed on, affixed to, painted on, sandblasted on, or located within the casement or sill area of a mineral glass window or other glazing. Dimensional letters attached to the glazing must have matching dimensional letters on each side of the glazing or a consistent and permanent opaque finish. Window sign area shall not exceed 25% of each window area.

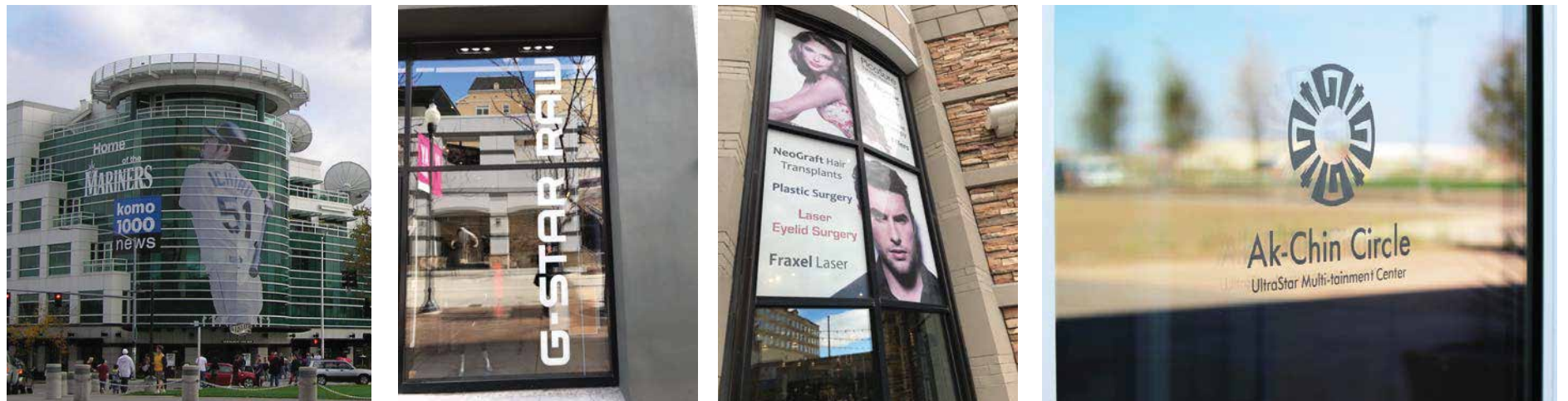

EXAMPLE WINDOW SIGNS