



9/8/20

modernwash COPYRIGHT 2020

5220 SCOTTSVILLE RD.  
BOWLING GREEN, KY 42104  
800.511.7208  
info@modernwash.net

**WADE'S XPRESS WASH**  
609 WEST MAIN STREET  
PLAINFIELD, INDIANA

































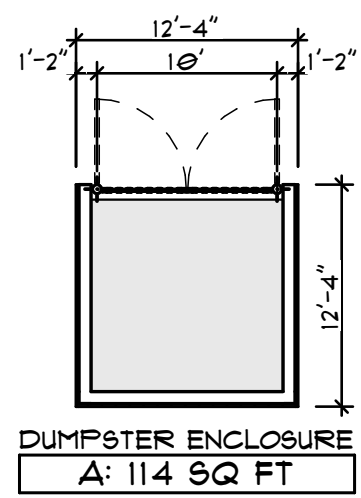
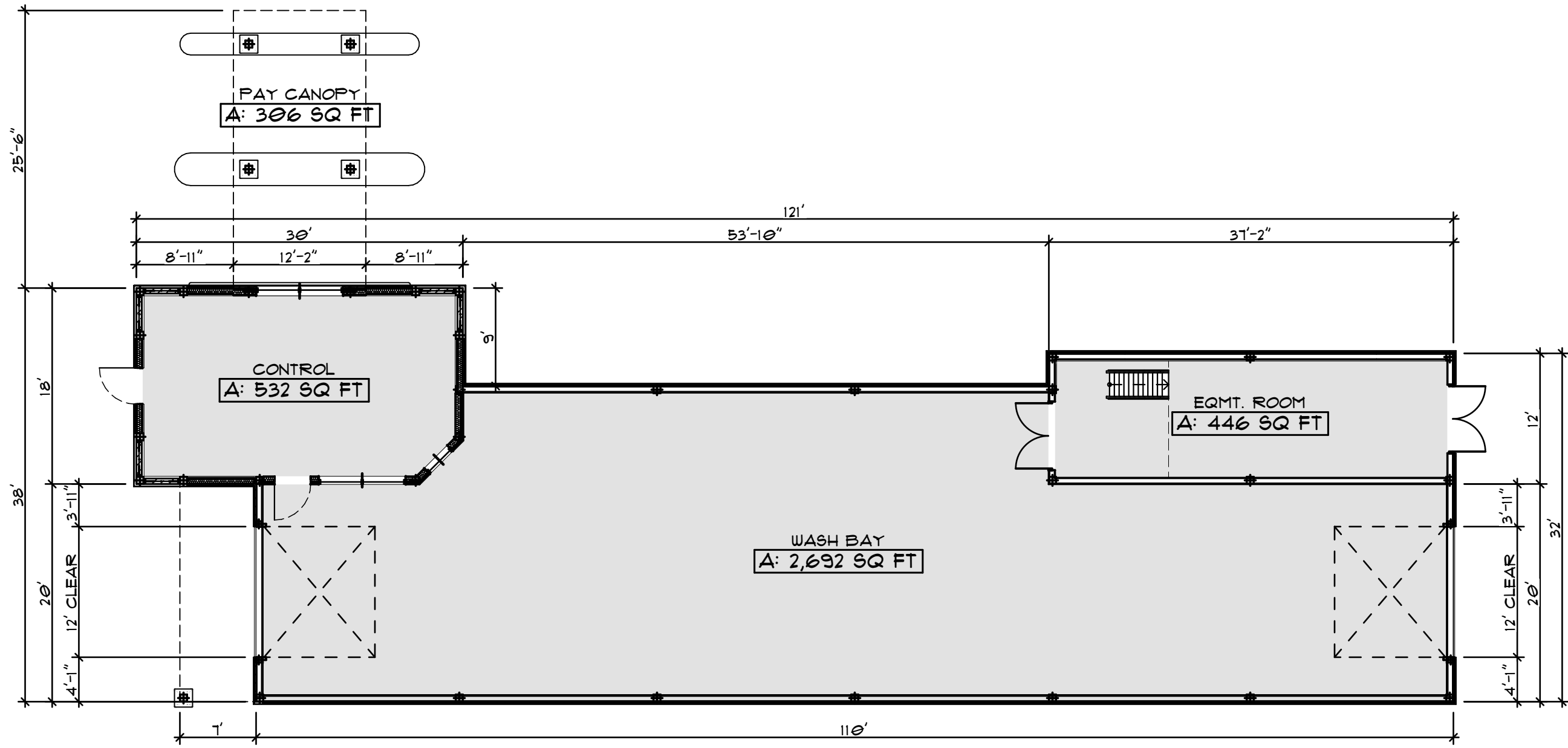

TYPICAL SPECIFICATIONS :

1. I-5 HIGH STRENGTH TUBULAR STEEL (HSS) STRUCTURAL FRAME MEMBERS. DESIGNED TO THE MOST RECENT IBC OR CURRENT LOCAL BUILDING CODES WITH STANDARD DESIGN LOADS OF THE GREATER VALUE OF 30LBS. PER S.F. LIVE LOAD AND 100 MPH SUSTAINED WIND LOAD OR SITE SPECIFIC CONDITIONS AND APPLICABLE ZONE REGARDING SEISMIC LOADS. CONNECTING BOLTS SHALL BE A-307 OR A-325 SPECIFICATIONS, HIDDEN AT ALL CONNECTIONS. ALL FRAME MEMBERS SHALL BE STRUCTURAL STEEL TUBE SIZED ACCORDING TO STRUCTURAL ENGINEERING CALCULATIONS MINIMUM .120 WALL THICKNESS.

2. ALL FRAME MEMBERS DESIGNED ACCORDING TO THE AMERICAN INSTITUTE OF STEEL CONSTRUCTION (AISC) FOR COLD FORMED STRUCTURAL MEMBERS. ALL FABRICATION WELDS SHALL BE IN ACCORDANCE WITH THE GUIDELINES OF THE AMERICAN WELDING SOCIETY (AWS). FIELD WELDING IS NOT REQUIRED.

3. STRUCTURAL CALCULATIONS AND STAMPED ENGINEERING IS PROVIDED TO MEET FEDERAL, LOCAL CODES AND SITE CONDITIONS DETERMINED BY ZONES.

FRAME FINISH :

1. ALL TUBULAR STRUCTURAL STEEL MEMBERS SHALL BE PREPARED WITH OUR I-5 FINISH SYSTEM WHICH IS A TGIC POLY POWDER COATING WITH A ZINC ENRICHED APPLIED PRIMER IN MULTIPLE LAYERS.

ROOFING :

1. PRE-FINISHED MEGA-RIB ROOF PANEL.

2. TOPGAL 21MM POLYCARBONATE STANDING SEAM ROOF SYSTEM.

OTHER ROOF SYSTEMS AVAILABLE. SEE MANUFACTURER FOR SPECIFIC MATERIALS SPECS.

GLAZING :

1. ALL STANDARD GLASS SYSTEMS SHALL BE STOREFRONT TYPE SYSTEMS WITH 1/4" UNINSULATED OR 1" INSULATED (INCOLDWEATHERPACKAGE) SAFETYGLASS. SECURED WITHIN 41/2" ANODIZED ALUMINUM FRAMEWORK WITH URETHANE SEALS.

KNEE WALL PANELS :

1. KNEE WALL GLAZING PANELS SHALL BE 3MM ALUMINUM COMPOSITE MATERIAL (ACM) IN COORDINATING COLORS.

2. SCREW ON STACKED CULTURED STONE.

PVC TUNNEL DIVISOR WALLS :

1. SHALL CONSIST OF GALVANIZED STEEL 18 GAUGE STUDS FORMING A WALL FRAME WITH SOLID SHEETING APPLIED TO THE TUNNEL SIDE, COVERED WITH A WATER RESISTANT WRAP (SIMILAR TO DUPONT TYVEK) WITH A 1/2" TONGUE AND GROOVE PVC PANELS APPLIED WITH MATCHING TRIMS.

MAN DOORS :

1. EQUIPMENT ROOM: STEEL SLAB PAINTED MAN DOORS @ ENTRANCE / EXTERIOR.

2. PVC WRAPPED FIBERGLASS MAN DOOR FOR EQUIPMENT ROOM TO TUNNEL ACCESS.

3. ALUMINUM MAN DOORS WITH GLASS AT ALL EXTERIOR OFFICE AREA LOCATIONS.

- FUEL RETAIL CUSTOM -

Car Wash  
MONOSLOPE ROOF & PAY CANOPY  
WITH SURROUND

Features:  
Stack N Tack Stone Cladding  
Metal Roof Panels  
NICHIHA Brick Panels

