

# WADE'S XPRESS WASH

## 603 W. MAIN STREET (US. 40), PLAINFIELD, INDIANA 46168

### CONSTRUCTION PLANS

PART OF SECTION 34-T15N-R1E  
 GUILFORD TOWNSHIP, HENDRICKS COUNTY  
 PLAINFIELD, INDIANA



Sheet List Table	
Sheet Number	Sheet Title
C101	TITLE SHEET
C102	EXISTING TOPOGRAPHY AND DEMOLITION PLAN
C103	SITE PLAN
C104	GRADING AND UTILITY PLAN
L1.01	LANDSCAPE SITE PLAN
LP1	LIGHTING SITE PLAN
APPENDICES	
1 of 1	RETRACEMENT SURVEY
A	ARCHITECTURAL PLANS
P	TOWN OF PLAINFIELD STANDARD DETAILS

#### UTILITY PROVIDER

**GAS**  
 Vectren Energy  
 1630 N. Meridian  
 Indianapolis, IN 46202  
 (317) 281-5261  
 (Gerry Jones)

**WATER**  
 Citizens Energy Group  
 1220 Waterway Blvd.  
 Indianapolis, IN 46202  
 (317) 635-3711  
 (Stanley Graves)

**ELECTRIC**  
 Indianapolis Power & Light  
 1230 W. Morris Street  
 Indianapolis, IN 46221  
 (317) 281-5261  
 (Ron Morris)

**WATER**  
 Plainfield Public Works  
 986 S. Center Street  
 Plainfield, IN 46168  
 (317) 839-3490  
 (Jason Castetter, Superint.  
 c/o Shannon Swan)

**ELECTRIC**  
 Duke Energy  
 5055 E. Main Street  
 Avon, IN 46123  
 (317) 745-1006  
 (Brian Bantley)

**SANITARY SEWER**  
 Plainfield Public Works  
 986 S. Center Street  
 Plainfield, IN 46168  
 (317) 839-3490  
 (Jason Castetter, Superint.  
 c/o Shannon Swan)

**TELEPHONE**  
 AT&T  
 240 N. Meridian Street  
 Indianapolis, IN 46204-1915  
 317-421-6709  
 (Michael Carter)

**DRAINAGE**  
 Plainfield Public Works  
 986 S. Center Street  
 Plainfield, IN 46168  
 (317) 839-3490  
 (Jason Castetter, Superint.  
 c/o Shannon Swan)

**UTILITY HOTLINE:** 1-800-382-5544 within Indiana 1-800-428-5200 outside Indiana  
 Note: The nature, size and location of utilities are per plans and locations provided by the respective utility companies together with field observation. The above list constitutes some, if not all, of the utility companies which provide service in the area of, and adjacent to, the subject property, based upon information available through such plans and locations, by incidental visual inspection. All utility companies should be notified prior to any excavation for field location of services and verification of size and nature of services.

#### GENERAL NOTES

1. THE CONTRACTOR SHALL CONFORM TO ALL LOCAL, STATE, AND FEDERAL CODES, OBTAIN ALL PERMITS, AND GIVE NOTICES REQUIRED FOR EXECUTION OF THE WORK.
2. ALL MATERIALS BEING REMOVED AND NOT RELOCATED UNDER THE NEW CONSTRUCTION, INCLUDING TREES, SHRUBS, SIGNS, UTILITIES, UTILITY STRUCTURES, ETC., SHALL BE FIRST OFFERED TO THE OWNER'S REPRESENTATIVE AND, IF NOT ACCEPTED, SHALL BE PROPERLY DISPOSED OF BY THE CONTRACTOR.
3. THE CONTRACTOR IS RESPONSIBLE FOR LOCATING ALL CHARTED AND UNCHARTED UTILITIES. TAKE CARE TO PROTECT UTILITIES THAT ARE TO REMAIN. REPAIR ANY DAMAGE TO LOCAL STANDARDS AND AT THE CONTRACTOR'S EXPENSE. COORDINATE ALL CONSTRUCTION WITH THE APPROPRIATE UTILITY COMPANY.
4. THE CONTRACTOR SHALL VERIFY THE LIMITS OF DEMOLITION WITH THE OWNER'S REPRESENTATIVE PRIOR TO COMMENCEMENT OF WORK.
5. IN AREAS WHERE EXISTING PAVEMENT, WALKS, OR CURBS ARE TO BE REMOVED, SAW CUT TO PROVIDE A CLEAN EDGE. COORDINATE EXTENT OF PAVEMENT DEMOLITION WITH THE LIMIT OF NEW IMPROVEMENTS ON THE SITE LAYOUT PLAN.
6. THE CONTRACTOR SHALL COORDINATE PHASING OF THE DEMOLITION WITH THE OWNER'S REPRESENTATIVE, ADJACENT PROPERTY LANDOWNERS, UTILITY REGULATIONS AND LOCAL AUTHORITIES, WHERE APPROPRIATE, PRIOR TO BEGINNING WORK. DISRUPTION OF THE EXISTING UTILITIES SHALL BE MINIMIZED TO THE EXTENT POSSIBLE AND INITIATED ONLY AFTER APPROVAL BY UTILITY REGULATIONS AND LOCAL AUTHORITIES.
7. CAVITIES LEFT BY STRUCTURE REMOVAL SHALL BE SUITABLY BACKFILLED AND COMPACTED IN ACCORDANCE WITH THESE PLANS AND SPECIFICATIONS.
8. THE CONTRACTOR IS RESPONSIBLE FOR ALL DEMOLITION AND REMOVAL NECESSARY TO ACCOMPLISH THE PROPOSED IMPROVEMENTS SHOWN ON THESE PLANS.
9. THE CONTRACTOR SHALL CALL THE INDIANA ONE CALL SYSTEM, HOLEY MOLEY, OR OTHER REQUIRED UTILITY LOCATION COMPANIES 72 HOURS PRIOR TO PROCEEDING WITH ANY EXCAVATION.
10. THE CONTRACTOR SHALL PRESERVE AND PROTECT SURVEY CONTROL POINTS AND SHALL BE RESPONSIBLE FOR REPLACEMENT OF ANY DISTURBED CONTROL POINTS.
11. EXISTING TREES TO BE PRESERVED ARE TO BE APPROPRIATELY BARRICADED PRIOR TO CONSTRUCTION.
12. ALL STORM PIPE IS TO REMAIN IN PLACE. ADJUST STRUCTURE T.C.'s AS SHOWN.

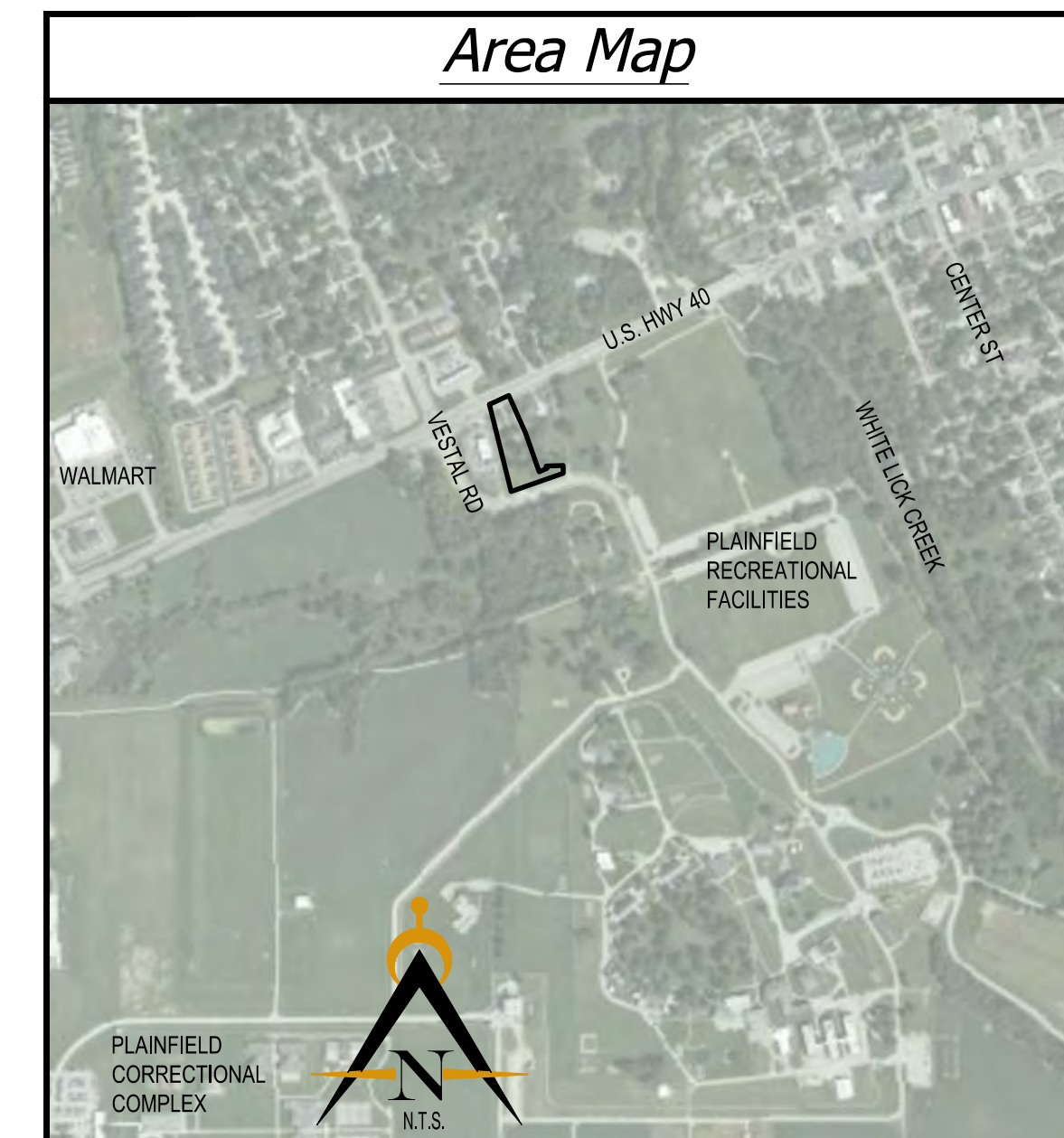

#### LEGAL DESCRIPTION

(Provided by Banning Engineering)

A part of the East half of the Northwest quarter of Section 34, Township 15 North, Range 1 East, Guilford Township, Hendricks County, Indiana, more particularly described as follows:  
 Beginning at a point on the East line of said Northwest quarter 818.40 feet North 0 degrees 44 minutes 26 seconds East from the southeast corner of the Northwest quarter of said section; thence bearing South 72 degrees 01 minutes 33 seconds West for a distance of 211.50 feet to a point; thence bearing North 13 degrees 10 minutes 00 seconds West for a distance of 613.77 feet to a point on the center line of the Old National Highway (U.S. 40); thence bearing North 65 degrees 57 minutes 00 seconds East and running on and along said center line for a distance of 98 feet to a point; thence bearing South 23 degrees 38 minutes 48 seconds East for a distance of 189.12 feet to a point; thence bearing South 19 degrees 12 minutes 20 seconds East for a distance of 188.40 feet to a point; thence bearing North 67 degrees 39 minutes 40 seconds East a distance of 39.31 feet to a point; thence bearing North 19 degrees 12 minutes 20 seconds West for a distance of 11.15 feet to a point; thence bearing North 87 degrees 45 minutes 40 seconds East for a distance of 84 feet to a point on the East quarter section line of the Northwest quarter of Section 34, Township 15 North, Range 1 East; thence bearing South 0 degrees 44 minutes 26 seconds West and running on and along said East quarter line for a distance of 249.30 feet to the point of beginning. Containing 2.49 acres, more or less, and subject to all legal highways, rights-of-way, and easements of record.

Except the land described in Instrument Number #20087447.  
 That portion of the Northwest Quarter of Section 34, Township 15 North, Range 1 East of the Second Principal Meridian, Town of Plainfield, Hendricks County, Indiana, described as follows:  
 Commencing at a 5/8 inch rebar with Banning Eng Firm #0060' cap set marking the southeast corner of said Northwest Quarter; thence North 00 degrees 34 minutes 27 seconds West (assumed bearing) along the east line thereof 813.95 feet (818.40 feet by deed) to the southwest corner of the land of Double H Property Management III, LLC as described in Instrument Number 2000-13463 in the Office of the Recorder of said county, said point being POINT OF BEGINNING; thence continue North 00 degrees 34 minutes 27 seconds West along said east line 97.96 feet to the proposed southerly line of Vestal Road; thence South 72 degrees 25 minutes 27 seconds West along said southerly line 214.77 feet to the beginning of a curve to the right having a radius of 242.00 feet, a central angle of 02 degrees 19 minutes 02 seconds, and a radial line passing through said point which bears South 21 degrees 50 minutes 08 seconds East, thence westerly along the arc of said curve and said southerly line 3.79 feet to the west line of said land; thence South 14 degrees 00 minutes 01 second East along said west line 97.68 feet; thence North 71 degrees 11 minutes 33 seconds East along the south line of said land 202.03 feet (211.50 feet by deed) to the POINT OF BEGINNING, containing 0.468 acres, more or less.  
 That portion of the Northwest Quarter of Section 34, Township 15 North, Range 1 East of the Second Principal Meridian, Town of Plainfield, Hendricks County, Indiana, described as follows:  
 Commencing at a 5/8 inch rebar with Banning Eng Firm #0060' cap set marking the southeast corner of said Northwest Quarter; thence North 00 degrees 34 minutes 27 seconds West (assumed bearing) along the east line thereof 911.91 feet to the POINT OF BEGINNING; thence South 72 degrees 25 minutes 27 seconds West 214.77 feet to the beginning of a curve to the right having a radius of 242.00 feet, a central angle of 02 degrees 19 minutes 02 seconds, and a radial line passing through said point which bears South 21 degrees 50 minutes 08 seconds East; thence westerly along the arc of said curve 3.79 feet to the west line of the land of Double H Property Management III, LLC as described in Instrument Number 2000-13463 in the Office of the Recorder of said county, thence North 14 degrees 00 minutes 01 second West along said west line 103.24 feet; thence North 70 degrees 45 minutes 10 seconds East 251.72 feet to the east line of the Quarter Section; thence South 00 degrees 34 minutes 27 seconds East along said east line 114.64 feet to the POINT OF BEGINNING, containing 25.183 square feet (0.578 acres), more or less.

#### Developer:

**WADE'S INVESTMENT'S LLC.**  
 3354 CHALLENGER DRIVE  
 PLAINFIELD, IN 46168  
 (317) 945-3006  
 CONTACT: JAKE WADE, OWNER

#### Engineer:

**Innovative**  
 ENGINEERING & CONSULTING  
 3961 Perry Boulevard  
 Ph. 317-769-2916  
 Whitestown, IN 46075  
 www.innovativeeci.com

**PRELIMINARY  
 PENDING  
 AGENCY  
 APPROVAL**

DATE:	DRAWN BY:
09/11/2020	ALR
ISSUED:	CHECKED BY:
	GD
JOB NUMBER:	
20111	
SHEET #	
<b>C101</b>	







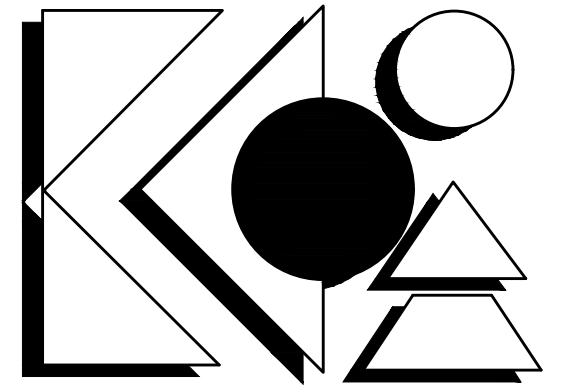

**KEVIN K. PARSONS & ASSOCIATES, INC.**  
 landscape architecture  
 land planning  
 urban design  
 212 West 10th Street - Suite A-290  
 Indianapolis, Indiana 46202  
 317-955-9155 - Fax 317-955-9455

PREPARED FOR:  
  
**Innovative**  
 ENGINEERING & CONSULTING  
 3961 Perry Boulevard  
 Ph. 317-769-2916  
 Whitestown, IN 46075  
 www.innovativeec.com

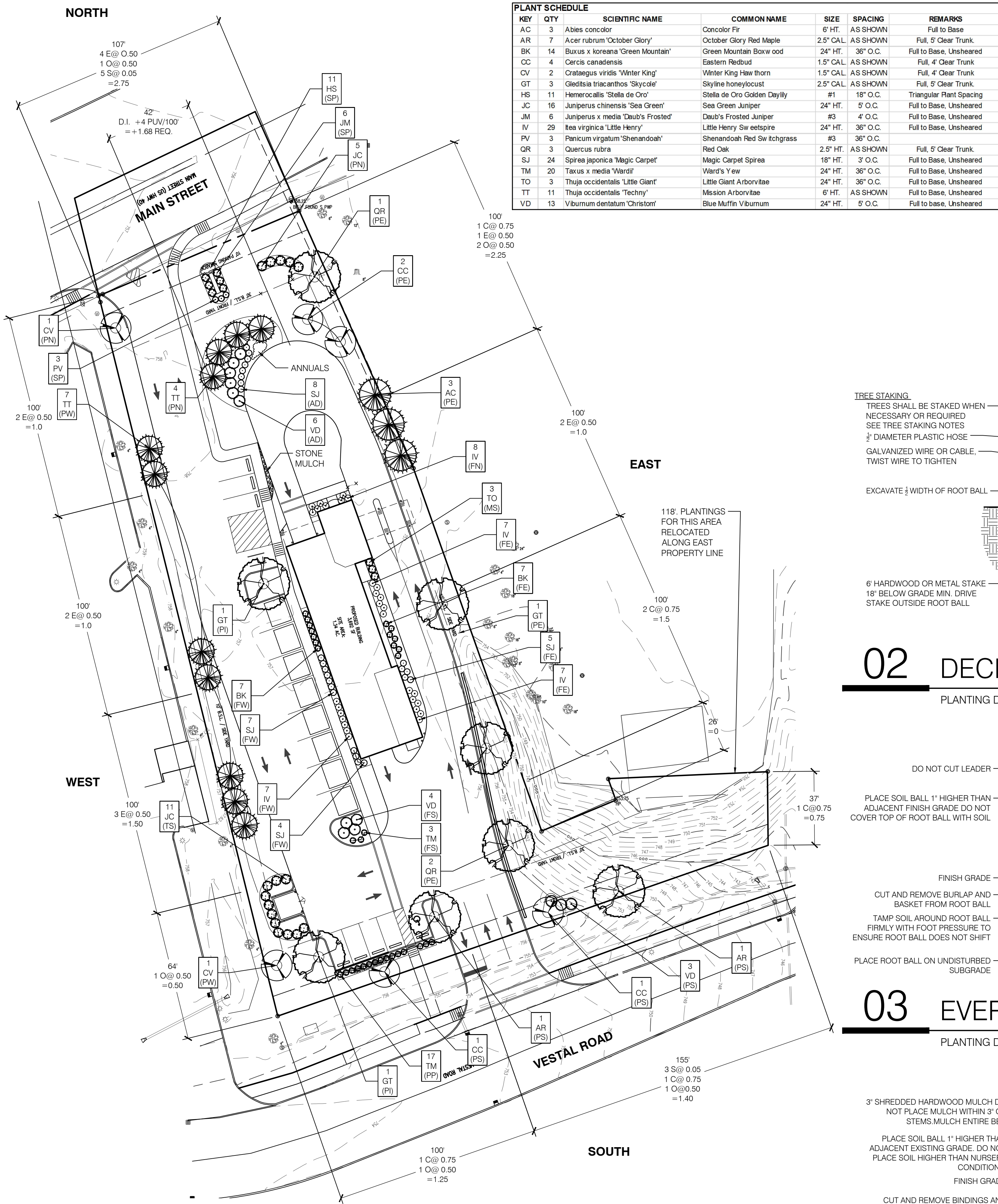

KEY	QTY	SCIENTIFIC NAME	COMMON NAME	SIZE	SPACING	REMARKS
AC	3	Abies concolor	Concolor Fir	6' HT.	AS SHOWN	Full to Base
AR	7	Acer rubrum 'October Glory'	October Glory Red Maple	2.5" CAL.	AS SHOWN	Full, 5' Clear Trunk
BK	14	Buxus x koreana 'Green Mountain'	Green Mountain Boxwood	24" HT.	36" O.C.	Full to Base, Unsheared
CC	4	Cercis canadensis	Eastern Redbud	1.5" CAL.	AS SHOWN	Full, 4' Clear Trunk
CV	2	Crataegus viridis 'Winter King'	Winter King Hawthorn	1.5" CAL.	AS SHOWN	Full, 4' Clear Trunk
GT	3	Gleditsia triacanthos 'Skycole'	Skyline honeylocust	2.5" CAL.	AS SHOWN	Full, 5' Clear Trunk
HS	11	Hemerocallis 'Stella de Oro'	Stella de Oro Golden Daylily	#1	18" O.C.	Triangular Plant Spacing
JC	16	Juniperus chinensis 'Sea Green'	Sea Green Juniper	24" HT.	5" O.C.	Full to Base, Unsheared
JM	6	Juniperus x media 'Dauis Frosted'	Dauis Frosted Juniper	#3	4" O.C.	Full to Base, Unsheared
IV	29	Ilex virginica 'Little Henry'	Little Henry Red Seespire	24" HT.	36" O.C.	Full to Base, Unsheared
PV	3	Panicum virgatum 'Shenandoah'	Shenandoah Red Sw itchgrass	#3	36" O.C.	
OR	3	Quercus rubra	Red Oak	2.5" HT.	AS SHOWN	Full, 5' Clear Trunk
SJ	24	Spiraea japonica 'Magic Carpet'	Magic Carpet Spiraea	18" HT.	3" O.C.	Full to Base, Unsheared
TM	20	Taxus x media 'Wardii'	Ward's Yew	24" HT.	36" O.C.	Full to Base, Unsheared
TO	3	Thuja occidentalis 'Little Giant'	Little Giant Arborvitae	24" HT.	36" O.C.	Full to Base, Unsheared
TT	11	Thuja occidentalis 'Techny'	Mission Arborvitae	6' HT.	AS SHOWN	Full to Base, Unsheared
VD	13	Viburnum dentatum 'Christom'	Blue Muffin Viburnum	24" HT.	5" O.C.	Full to base, Unsheared

**LEGEND**

SYMBOL	DESCRIPTION	PLANT QUANTITY PLANT TYPE REQ. LOCATION
(AD)	ADDITIONAL PLANTING - NOT REQUIRED	
(FN)	NORTH PERIMETER REQUIREMENTS	
(FE)	EAST PERIMETER REQUIREMENTS	
(PS)	SOUTH PERIMETER REQUIREMENTS	
(PW)	WEST PERIMETER REQUIREMENTS	
(FN)	NORTH FOUNDATION REQUIREMENTS	
(FE)	EAST FOUNDATION REQUIREMENTS	
(FS)	SOUTH FOUNDATION REQUIREMENTS	
(FW)	WEST FOUNDATION REQUIREMENTS	
(PI)	PARKING LOT INTERIOR REQUIREMENTS	
(PP)	PARKING LOT PERIMETER REQUIREMENTS	
(TS)	TRASH SCREENING REQUIREMENTS	
(SP)	SIGN PLANTING REQUIREMENTS	
(MS)	MECHANICAL SCREENING REQUIREMENTS	

**FOUNDATION PLANT VALUE CHART**

LOCATION	DIST.	TOTAL AREA	TOTAL VALUE	REQUIRED VALUE
SOUTH FOUNDATION	32'	229 SF	0.35	0.32
EAST FOUNDATION	127'	459 SF	1.30	1.27
NORTH FOUNDATION	38'	92 SF	0.40	0.38
WEST FOUNDATION	121'	301 SF	1.25	1.21

**SIGN PLANT VALUE CHART**

LOCATION	ASSUMED SIGN AREA	PLANT AREA	EVGRN. SHRUBS
NORTH MONUMENT SIGN	160 SF	176 SF	6

**PERIMETER PLANT VALUE CHART**

LOCATION	DIST.	TOTAL VALUE	AVERAGE 100' VALUE	REQUIRED VALUE
SOUTH YARD (FRONT YARD)	256'	2.65	1.14	1
EAST YARD	481'	5.50	1.14	1
NORTH YARD (FRONT YARD)	107'	1.15	1.07	1
WEST YARD	364'	4.00	1.09	1
TRASH SCREENING	44'	0.45	1.02	1
<b>TOTAL</b>		<b>5.43</b>		<b>5</b>

**PARKING LOT TREE VALUES**

NO. OF SPACES	TREES REQUIRED	TREES PROVIDED
16	2	2

**PARKING LOT PERIMETER**

24" TALL HEDGE 36" O.C. REQUIRED  
 24" TALL HEDGE 36" O.C. PROVIDED

**NOTES**

- GENERAL NOTES:**
- ALL UTILITIES SHALL BE LOCATED AND MARKED/FLAGGED PRIOR TO BEGINNING WORK. RELOCATE PLANTS FROM OVER OR UNDER UTILITIES. RELOCATION SHALL BE APPROVED BY OWNER AND/OR LANDSCAPE ARCHITECT PRIOR TO INSTALLATION.
  - UTILITY LOCATION NOTE: ALL LOCATIONS SHOWN ARE APPROXIMATE AND BASED ON INFORMATION SUPPLIED BY EITHER THE CIVIL ENGINEER, SURVEYOR, OWNER, AND/OR MEASURED IN THE FIELD. IF DISCREPANCIES ARE PRESENT, CONTRACTOR SHALL NOTIFY OWNER AND LANDSCAPE ARCHITECT IMMEDIATELY AND PRIOR TO BEGINNING WORK.
  - IN CASE OF DISCREPANCIES BETWEEN THE PLAN AND THE PLANT LIST, THE PLAN SHALL DICATE.
  - LANDSCAPE CONTRACTOR IS RESPONSIBLE FOR ALL PREPARATION, MATERIALS, DELIVERY, INSTALLATION AND INITIAL MAINTENANCE FOR THE LANDSCAPE PORTION OF THE PROJECT AS SHOWN ON THE DRAWINGS AND AS DIRECTED BY THE OWNER'S REPRESENTATIVE. THE LANDSCAPE CONTRACTOR SHALL OBTAIN AND PAY FOR ALL PERMITS AND FEES THAT MAY BE REQUIRED FOR THEIR PORTION OF WORK.
  - PLANTS AND ALL OTHER MATERIALS TO BE STORED ON SITE WILL BE PLACED WHERE THEY WILL NOT CONFLICT W/ CONSTRUCTION OPERATIONS AND AS DIRECTED BY OWNER'S REPRESENTATIVE.
  - CLEAN UP ALL DEBRIS AND REMOVE FROM SITE. REPAIR ALL DAMAGED OR DISTURBED AREAS CAUSED BY LANDSCAPE WORK.
  - TOPSOIL NOTE:** TOPSOIL SHALL BE FRIABLE, NATURAL LOAM, SURFACE SOIL AND FREE OF SUBSOIL, CLAY LUMPS, BRUSH, WEEDS, LITTER, ROOTS, STUMPS, STONES, AGRICULTURAL AND DOMESTIC FERTILIZERS, CHEMICALS, HERBICIDES, AND OTHER EXTRANEOUS OR TOXIC MATTER HARMFUL TO PLANT GROWTH AND THE ENVIRONMENT. WASTE SOILS, BORROW, OR HEAVY CLAY BASED SOILS WILL NOT BE ACCEPTED. TOPSOIL SHALL HAVE A PH VALUE OF 6.0 TO 7.4 AND AN ORGANIC VALUE OF 3% TO 5%. SUBMIT SOIL SAMPLES, PH LEVELS, AND NPK ANALYSIS PRIOR TO DELIVERY TO SITE.
- PLANTING NOTES:**
- REMOVE WEEDS, ORGANIC MATTER AND ROCKS LARGER THAN 1.5" FROM SOIL.
  - BACKFILL FOR TREE PLANTING SHALL BE 75% TOPSOIL AND 25% ORGANIC COMPOST. TOP LAYER OF BACKFILL SHALL BE 100% OF SURROUNDING TOPSOIL. A 5-10-5 ANALYSIS SLOW RELEASE FERTILIZER SHALL BE INCORPORATED INTO BACKFILL AT APPROVED RATES.
  - THE TOPS OF ALL TREE AND SHRUB ROOT BALLS TO BE PLACED A MAXIMUM OF ONE (1) INCH ABOVE FINAL GRADE. ALL TREES LOCATED OUTSIDE OF BEDS SHALL HAVE A MINIMUM SIX (6) FOOT DIAMETER NON-LIPPED SAUCER AROUND PLANTING PIT. ALL SAUCERS SHALL BE WEED AND GRASS FREE. AN APPROVED PRE-EMERGENT HERBICIDE SHALL BE APPLIED IN ALL PLANTING BEDS AT A RATE SPECIFIED BY MANUFACTURER FOR EACH PLANT VARIETY.
  - ALL TREE SAUCERS AND PLANTING BEDS SHALL RECEIVE MINIMUM OF THREE (3) INCHES GRADE A, SHREDDED HARDWOOD BARK MULCH. NO CYPRESS, WOOD CHIPS, ARTIFICIAL OR DYED MULCH ALLOWED.
  - NO SUBSTITUTIONS OF PLANT MATERIALS WILL BE ALLOWED. IF PLANTS ARE NOT AVAILABLE, THE CONTRACTOR SHALL NOTIFY LANDSCAPE ARCHITECT/ OWNER'S REPRESENTATIVE IN WRITING. ALL PLANTS SHALL BE INSPECTED AND TAGGED WITH PROJECT I.D. AT NURSERY OR CONTRACTORS OPERATIONS PRIOR TO MOVING TO JOB SITE. PLANTS MAY BE INSPECTED AND APPROVED OR REJECTED ON THE JOB SITE BY LANDSCAPE ARCHITECT OR OWNER'S REPRESENTATIVE.
  - THE OWNER, OWNER'S AGENT, OR THE LANDSCAPE ARCHITECT RESERVES THE RIGHT TO REJECT ANY AND ALL PLANT MATERIALS AT ANY TIME DURING THE COURSE OF THE PROJECT UNTIL PROJECT IS ACCEPTED BY THE OWNER.
  - LANDSCAPE CONTRACTOR SHALL LAYOUT AND STAKE ALL PLANT LOCATIONS AS SHOWN ON THE DRAWINGS PRIOR TO INSTALLATION. OWNERS REPRESENTATIVE OR LANDSCAPE ARCHITECT SHALL INSPECT AND APPROVE PLANT LOCATIONS FOR ACCURACY AND COMPLIANCE WITH DESIGN INTENT PRIOR TO INSTALLATION.
  - LANDSCAPE CONTRACTOR IS RESPONSIBLE FOR THE PLANTING OF SPECIFIED PLANTS AND MAINTAINING ALL PLANT MATERIALS IN AN ALIVE AND QUALITY CONDITION UNTIL ACCEPTANCE BY THE OWNER. THIS INCLUDES AS A MINIMUM WATERING, WEEDING, INSECT AND DISEASE CONTROL, PRUNING OF DAMAGED OR UNSIGHTLY LIMBS, AND KEEPING PLANTS IN TRUE AND UPRIGHT POSITIONS.
  - CONTRACTOR SHALL GUARANTEE AND WARRANT ALL PLANT MATERIAL TO REMAIN ALIVE AND HEALTHY FOR ONE (1) YEAR FROM DATE OF ACCEPTANCE BY THE OWNER. ALL REPLACEMENTS SHALL BE PAID FOR BY THE CONTRACTOR AT NO ADDITIONAL COST TO THE OWNER. GUARANTEE/WARRANTY REPLACEMENTS SHALL BE AS DIRECTED BY THE OWNER UNTIL FINAL ACCEPTANCE OF THE PROJECT FOLLOWING THE GUARANTEE PERIOD.
- SEEDING AND PREPARATION:**
- CONTRACTOR TO FINE GRADE AND PREPARE ALL SITE AREAS TO RECEIVE SEED. MAKE SITE SMOOTH TO FINAL GRADING PLAN ELEVATIONS. FILL IN DEPRESSIONS, LOW SPOTS AND GRADE SMOOTH.
  - ALL SEEDED LAWN AREAS WITHIN LIMIT LINES TO RECEIVE 6" TOPSOIL PRIOR TO SEEDING OPERATIONS. ONCE TOPSOIL HAS BEEN PLACED, CONSTRUCTION ACTIVITY OF ANY KIND (EXCLUDING LANDSCAPING) SHALL NOT BE PERMITTED ON OR ACROSS ANY PLANTING AREA.
  - HYDROSEEDING IS ACCEPTABLE. APPLY WITH APPROVED EQUIPMENT DESIGNED FOR PROFESSIONAL HYDROSEEDING APPLICATIONS AT RECOMMENDED RATES.
  - PROVIDE FRESH, CLEAN NEW-CROP PREMIUM GRADE SEED AND SEED MIXES AS FOLLOWS: (SUBMIT SEASONAL MIX ALTERNATIVE AS APPROPRIATE)  
 40% KENTUCKY BLUEGRASS  
 30% PERENNIAL RYE GRASS  
 30% TURF TYPE TALL FESCUE
  - APPLY SEED AT RATE OF MINIMUM 175 POUNDS PER ACRE (4 LBS/1000SF).
  - SCARIFY SOIL TO DEPTH OF 3 INCHES PRIOR TO APPLICATION.
  - LAWNS SHALL BE SEED FOLLOWING SCARIFYING, FINAL GRADING, FERTILIZING, AND RAKING. LAWN SHALL BE FERTILIZED W/ 12-12-12 ANALYSIS FERTILIZER AT A RATE OF 10 lbs./1000 s.f. APPLY SEED MIX AT SPECIFIED RATE, AND LIGHTLY RAKE INTO TOP 1/4 INCH OF SOIL.
  - MULCH SEEDED AREAS WITH STRAW MULCH AT RATE OF MINIMUM 1 1/2 TON PER ACRE (70 LBS/1000SF). CRIMP OR TACK STRAW MULCH TO REMAIN IN PLACE UNTIL COMPLETE GERMINATION OF SEED AND ESTABLISHED GROWTH. COORDINATE WITH EROSION CONTROL PLAN.
  - WATER AND MAINTAIN GRASS UNTIL STAND IS ESTABLISHED AND READY FOR MOWING AT MINIMUM 4 INCH HEIGHT. CONTINUE TO WATER FOR A MINIMUM 30 DAYS OR UNTIL ACCEPTED BY OWNER.
  - FOLLOWING SEEDING OPERATIONS, CLEAN UP EXCESS MATERIALS, AND CLEAN ALL BARK MULCHED AND PAVED AREAS.
  - FOLLOWING GERMINATION, APPLY HERBICIDE TO ALL GRASS GROWTH IN PLANT MULCH AREAS.
  - ALL LAWNS SHALL BE GUARANTEED TO HAVE A FULL UNIFORM STAND OF ACCEPTABLE GRASS AT THE END OF THE ONE YEAR GUARANTEE PERIOD WITH NO BARE SPOTS COMPRISING MORE THAN 2% OF ANY LAWN AREA. ANY AREA SO NOTED WILL BE RESEEDED OR SOEDD UNTIL AN ACCEPTABLE STAND OF GRASS IS ESTABLISHED.
  - ALL DISTURBED LAWN AREAS SHALL BE SEED AS NOTED AND AS APPROVED BY OWNERS REPRESENTATIVE AND LANDSCAPE ARCHITECT.
- TREE STAKING NOTES:**
- CONTRACTOR TO STAKE WHEN NECESSARY OR REQUIRED, SUCH AS WIND PRONE AREAS OR UNSTABLE SOILS. STAKES SHALL BE PLACED IN MULCHED AREAS TO ALLOW FOR MOVING ADJACENT TURF.
  - STAKING SHOULD NOT BE USED TO COMPENSATE FOR DAMAGED OR WEAK TRUNKS OR ROOT BALLS. THESE TREES SHOULD BE REJECTED.
  - REMOVE ALL STAKING AS SOON AS THE TREE HAS GROWN SUFFICIENT ROOTS TO OVERCOME THE PROBLEM THAT REQUIRED THE TREE TO BE STAKED. STAKES SHALL BE REMOVED NO LATER THAN THE END OF THE FIRST GROWING SEASON AFTER PLANTING.
  - ASSURE THAT THE BEARING SURFACE OF THE PROTECTIVE COVERING OF THE WIRE OR CABLE AGAINST THE TREE TRUNK IS A MINIMUM OF 12 MM (0.5 IN.).
  - WIRES OR CABLE SIZES SHALL BE 14 TO 12 GAUGE.
  - TIGHTEN WIRE OR CABLE ONLY ENOUGH TO KEEP FROM SLIPPING. ALLOW FOR SOME TRUNK MOVEMENT. PLASTIC HOSE TO BE LONG ENOUGH TO ACCOMMODATE 1.5' OF GROWTH AND BUFFER ALL BRANCHES FROM THE WIRE.
  - TUCK ANY LOOSE ENDS OF THE WIRE OR CABLE INTO THE WIRE WRAP SO THAT NO SHARP WIRE ENDS ARE EXPOSED.

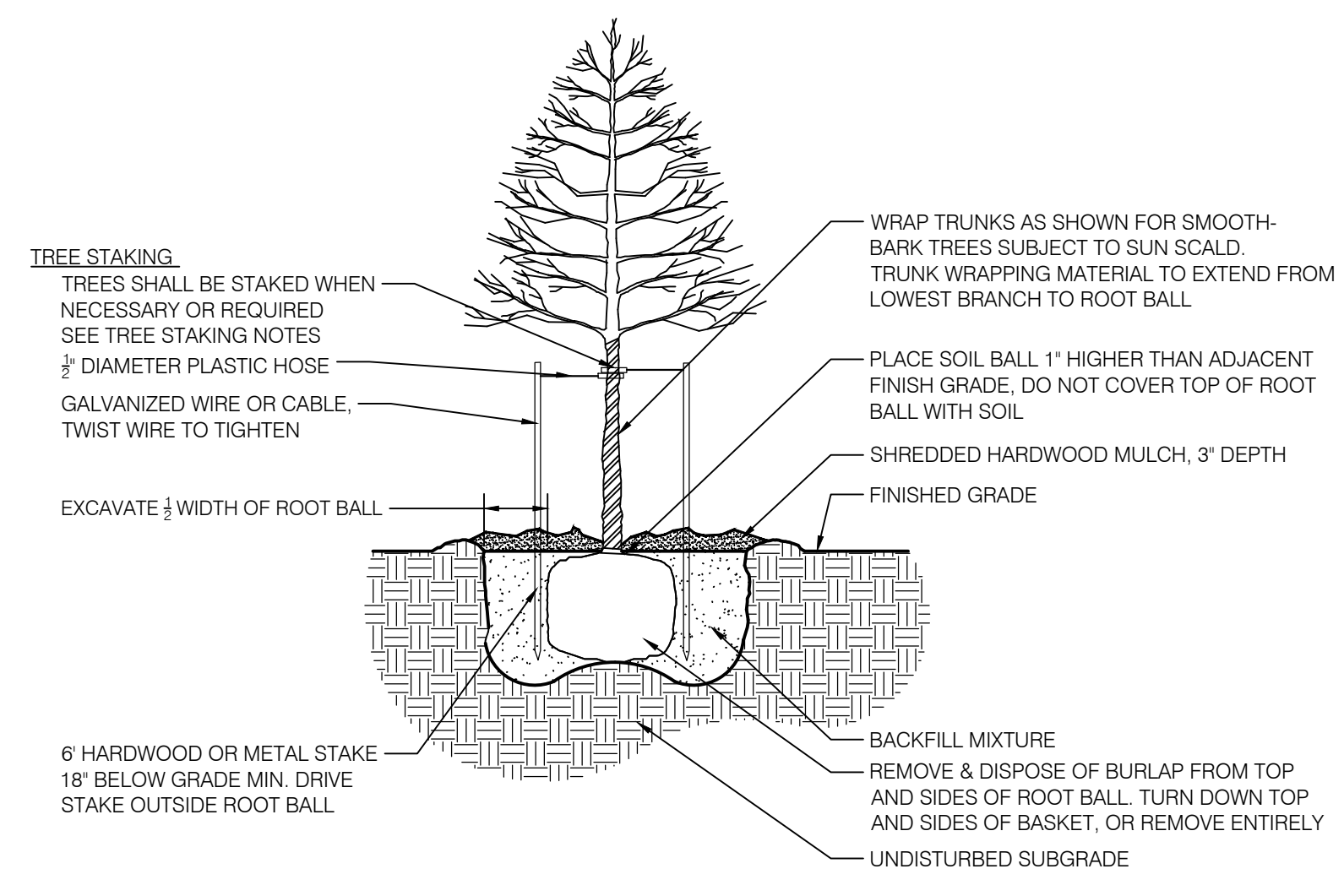

**02 DECIDUOUS TREE**

PLANTING DETAIL - NOT TO SCALE

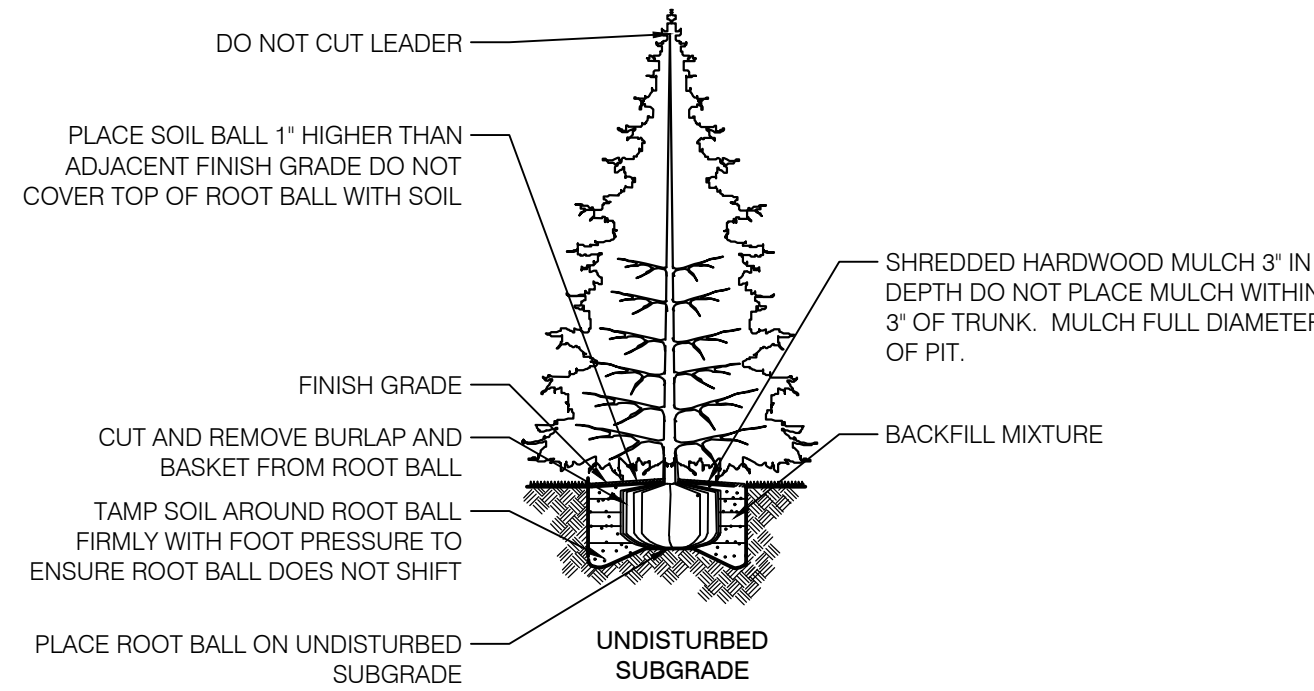

**03 EVERGREEN TREE**

PLANTING DETAIL - NOT TO SCALE

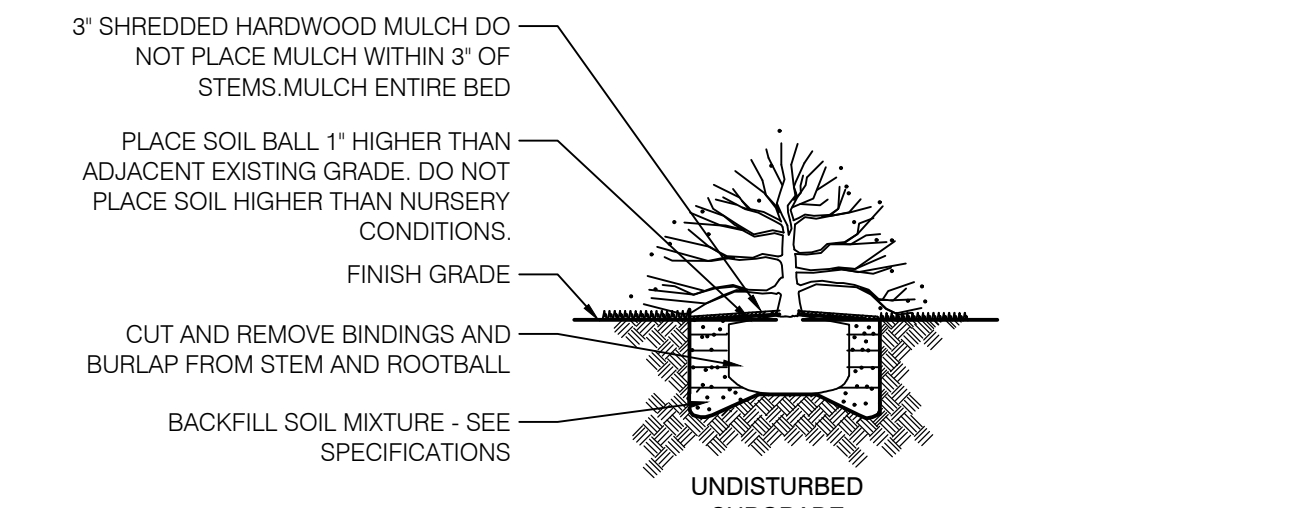

**04 SHRUB**

PLANTING DETAIL - NOT TO SCALE

**01 WADE'S CAR WASH SITE LANDSCAPE PLAN**

L1.01 1"=30'-0"

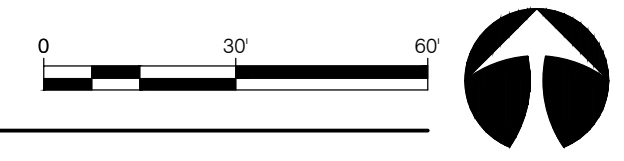

PRELIMINARY  
 NOT FOR CONSTRUCTION  
 CERTIFICATION

WADE'S CAR WASH  
 603 W. MAIN STREET  
 PLAINFIELD, IN 46168

**SITE LANDSCAPE PLAN**

PROJECT: KPA-20516  
 DRAWN: DM  
 CHECKED: JML  
 SCALE: AS SHOWN  
 ISSUE DATE: 07/16/2020  
 REVISION: 08/21/2020  
 08/25/2020  
 09/03/2020

SITE LANDSCAPE PLAN

**L1.01**

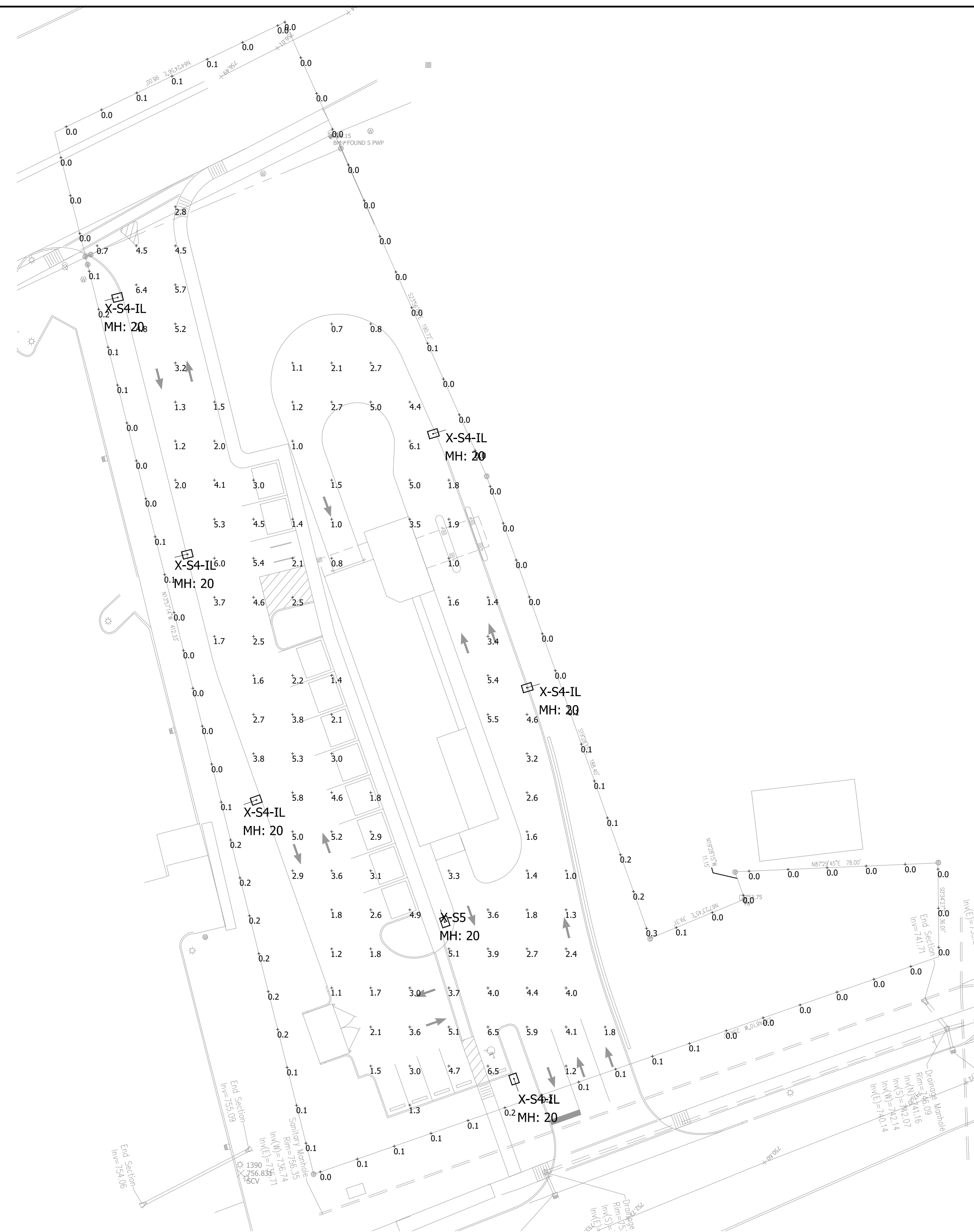

Luminaire Schedule							
Symbol	Qty	Label	Arrangement	Lum. Lumens	LLF	Lum. Watts	Description
	6	X-S4-IL	SINGLE	16252	0.900	187	MRM-LED-24L-SIL-FT-50-70CRI-IL
	1	X-S5	SINGLE	23823	0.900	188.8	SLM-LED-24L-SIL-5W-50-70CRI

Calculation Summary							
Label	CalcType	Units	Avg	Max	Min	Avg/Min	Max/Min
Paved Areas & Drives	Illuminance	Fc	3.10	6.5	0.7	4.43	9.29
Property Line	Illuminance	Fc	0.06	0.3	0.0	N.A.	N.A.

**LIGHTING NOTES:**  
 - Mounting Height = 20'  
 - Light Loss Factor = 0.90  
 - Footcandle Values Calculated @ Grade  
 - Reflectance Values - 80/50/20 (office spaces)  
 50/30/20 (warehouse areas)

**National Lighting Vendor:**  
 For pricing and technical assistance contact:  
 Russ Miller of CBMC INC, tel# 317-697-7510,  
 rmiller@cbmcinc.com

All electrical work shall comply with National, State, and Local codes including and not limited to the National Electric Code, NFPA 101 Life Safety Code, ASHREA and /or IECC Energy Codes.  
 The information contained in this document is proprietary to CBMC Lighting Solutions. This document is prepared for a specific site and incorporates calculations based on data available from the client at this time. By accepting and using this document, the recipient agrees to protect its contents from further dissemination, (other than that within the organization necessary to evaluate such specification) without the written permission of CBMC Lighting Solutions. The contents of this document are not to be reproduced or copied in whole or in part without the written permission of CBMC Lighting Solutions. copyright © 2018 CBMC Lighting Solutions all rights reserved.

**CBMC LIGHTING SOLUTIONS**  
 5855 KOPETSKY DR. SUITE G. | INDIANAPOLIS, IN 46217  
 317-780-8350 | WWW.CBMCINC.COM

SEE MORE

This lighting pattern represents illumination levels calculated from laboratory data taken under controlled conditions in accordance with IESNA approved methods. Actual performance of any manufacturer's luminaire may vary due to variation in electrical voltage, tolerance in lamps and LED lumen package, location adjustments, and other variable field conditions.  
 Contractor to check and verify all dimensions on site before commencing any work shown.

Wade's Car Wash - Plainfield

SITE LAYOUT			
Scale:	1" = 30'	Drawing No:	LP1
Date:	8/20/20	Project No:	CB17105-SITE-2
Drawn By:	SJM		-

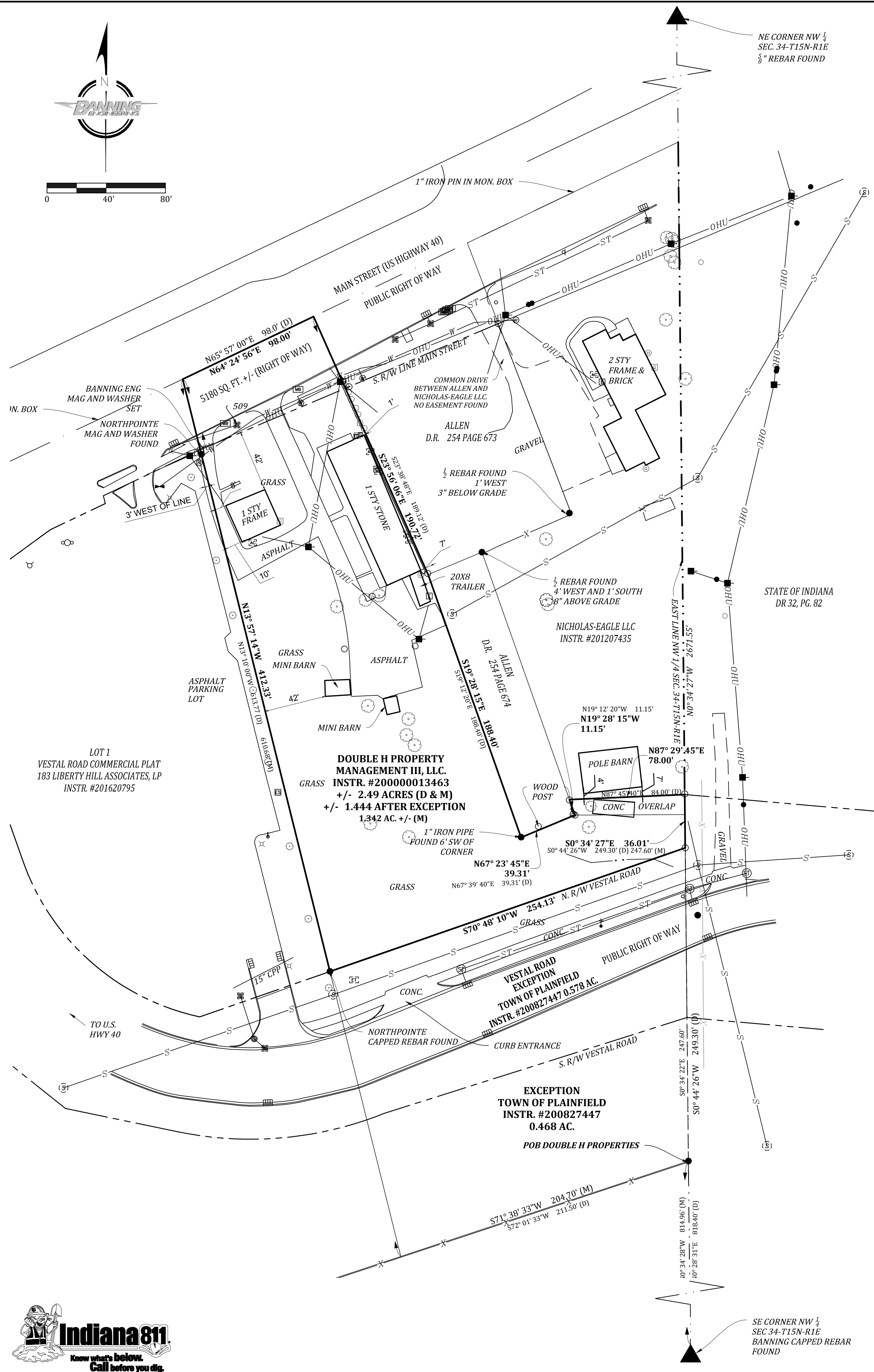

**LEGEND**

- PROPERTY LINE
  - - - SECTION LINE
  - RIGHT-OF-WAY LINE
  - OHU OVERHEAD UTILITY LINE
  - ST STORM SEWER LINE
  - S SANITARY SEWER LINE
  - W WATERLINE
  - WV WATER VALVE
  - WM WATER METER
  - FD FIRE HYDRANT
  - UP UTILITY POLE
  - GA GUY ANCHOR
  - LP LIGHT POLE
  - SM STORM MANHOLE
  - SI STORM INLET
  - TS TELEPHONE STRUCTURE
  - TSC TRAFFIC SIGNAL CONTROLLER
  - TSM TRAFFIC SIGNAL MANHOLE
  - SM SANITARY MANHOLE
  - SP STRAIN POLE
- LAND DESCRIPTION**
- 4 HANDHOLE
  - 4 SIGN
  - 4 CLEANOUT
  - 4 GAS METER
  - 4 GAS LINE MARKER
  - 4 ELECTRIC METER
  - 4 ELECTRIC TRANSFORMER
  - 4 MAIL BOX
  - 4 AIR CONDITIONING UNIT
  - 4 TREE
  - 4 REBAR W/CAP STAMPED
  - 4 "BANNING ENGINEERING FIRM#0060" SET
  - 4 FOUND MONUMENT
  - 4 SECTION CORNER



**VICINITY MAP**

Instrument #200013463:  
A part of the East half of the Northwest quarter of Section 34, Township 15 North, Range 1 East, Guilford Township, Hendricks County, Indiana, more particularly described as follows:  
Beginning at a point on the East line of said Northwest quarter 818.40 feet North 0 degrees 44 minutes 26 seconds East from the southeast corner of said section; thence bearing south 72 degrees 01 minutes 33 seconds West for a distance of 211.50 feet to a point; thence bearing North 13 degrees 10 minutes 00 seconds West for a distance of 613.77 feet to a point on the center line of the Old National Highway (U.S. 40); thence bearing North 65 degrees 57 minutes 00 seconds East and running on and along said center line for a distance of 98 feet to a point; thence bearing South 23 degrees 38 minutes 48 seconds East for a distance of 189.12 feet to a point; thence bearing South 19 degrees 12 minutes 20 seconds East for a distance of 188.40 feet to a point; thence bearing North 67 degrees 39 minutes 40 seconds East a distance of 39.31 feet to a point; thence bearing North 19 degrees 12 minutes 20 seconds West for a distance of 11.15 feet to a point; thence bearing North 87 degrees 45 minutes 40 seconds East for a distance of 84 feet to a point on the East quarter section line of the Northwest quarter of Section 34, Township 15 North, Range 1 East; thence bearing South 0 degrees 44 minutes 26 seconds West and running on and along said East quarter line for a distance of 249.30 feet to the point of beginning. Containing 2.49 acres, more or less, and subject to all legal highways, rights-of-way, and easements of record.

Except the land described in Instrument Number #200827447:  
That portion of the Northwest Quarter of Section 34, Township 15 North, Range 1 East of the Second Principal Meridian, Town of Plainfield, Hendricks County, Indiana, described as follows:  
Commencing at a 5/8 inch rebar with "Banning Eng Firm #0060" cap set marking the southeast corner of said Northwest Quarter; thence North 00 degrees 34 minutes 27 seconds West (assumed bearing) along the east line thereof 813.95 feet (818.40 feet by deed) to the southeast corner of the land of Double H Property Management III, LLC as described in Instrument Number 2000-13463 in the Office of the Recorder of said county, said point being POINT OF BEGINNING; thence continue North 00 degrees 34 minutes 27 seconds West along said east line 97.96 feet to the proposed southerly line of Vestal Road; thence South 72 degrees 25 minutes 27 seconds West along said southerly line 214.77 feet to the beginning of a curve to the right having a radius of 242.00 feet, a central angle of 02 degrees 19 minutes 02 seconds, and a radial line passing through said point which bears South 21 degrees 08 minutes 08 seconds East, thence westerly along the arc of said curve and said southerly line 9.79 feet to the west line of said land; thence South 14 degrees 00 minutes 01 second East along said west line 97.68 feet; thence North 71 degrees 11 minutes 32 seconds East along the south line of said land 202.03 feet (211.50 feet by deed) to the POINT OF BEGINNING, containing 0.468 acres, more or less.

That portion of the Northwest Quarter of Section 34, Township 15 North, Range 1 East of the Second Principal Meridian, Town of Plainfield, Hendricks County, Indiana, described as follows:  
Commencing at a 5/8 inch rebar with "Banning Eng Firm #0060" cap set marking the southeast corner of said Northwest Quarter; thence North 00 degrees 34 minutes 27 seconds West (assumed bearing) along the east line thereof 911.91 feet to the POINT OF BEGINNING; thence South 72 degrees 25 minutes 27 seconds West 214.77 feet to the beginning of a curve to the right having a radius of 242.00 feet, a central angle of 02 degrees 19 minutes 02 seconds, and a radial line passing through said point which bears South 21 degrees 08 minutes 08 seconds East; thence westerly along the arc of said curve 9.79 feet to the west line of the land of Double H Property Management III, LLC as described in Instrument Number 2000-13463 in the Office of the Recorder of said county; thence North 14 degrees 00 minutes 01 second West along said west line 103.24 feet; thence North 70 degrees 48 minutes 10 seconds East 251.72 feet to the east line of the Quarter Section; thence South 00 degrees 34 minutes 27 seconds East along said east line 114.64 feet to the POINT OF BEGINNING, containing 25,183 square feet (0.578 acres), more or less.

**SURVEYOR'S REPORT**

In accordance with Title 865, Article 1, Chapter 12 of the Indiana Administrative Code ("Rule 12"), the following observations, opinions, and comments are declared regarding the various uncertainties in the locations of lines and corners found or located this survey as a result of the uncertainties in reference monumentation; in record descriptions and plats; in lines of occupation; and as introduced by random errors in measurements ("Relative Positional Accuracy"). There may be unwritten rights associated with these uncertainties. The client should assume there is an amount of uncertainty along any title line equal in magnitude to the discrepancy in the location of the lines of possession from the surveyed lines.

The purpose of this survey was to perform a retracement boundary survey on the land of Double H Property Management III, LLC and recorded as Instrument Number 200827447 in the Office of the Recorder of Hendricks County. Information and data used to perform this survey includes, but is not limited to, the following: the deeds and/or plats of the surveyed property and adjoining properties, surveys completed by the undersigned in the vicinity of the surveyed property and monuments and physical evidence found as shown on the plat of the survey.

**REFERENCE DOCUMENTS**  
Reference documents recovered, analyzed and used in this survey consisted of the following:

Surveys and Maps from Hendricks County Archives; a survey by Brian L. Haggard per Project Number 17030; a route survey completed by Brian L. Haggard per Project Number 05101; a survey by Hahn provided in cad format with a previous survey; an Auditor's Plat Map from the Hendricks County Archive;

**BASIS OF BEARINGS**  
The basis of bearings for this plat of survey is the use of a State Plane grid system derived from the West Zone of the Indiana State Plane Coordinate System (1302 IN West Zone - N.A.D. 1983), 2011 adjustment. Geoid Model 18 was used for all GPS observations. The said system was verified utilizing the VRS Network, a real-time kinematic (RTK) correction service over the internet. This survey has been performed in US Survey Feet. All measurements on this survey are derived from grid coordinates.

There may be differences of deed dimensions versus measured dimensions along the title lines shown hereon and, likewise, survey markers may be found near, but not precisely at, some title corners. In cases where the magnitude of this difference is less than the Relative Positional Accuracy (stated below) and/or less than the uncertainty identified for the reference monumentation (discussed below), the difference may be considered insignificant and is shown only for the purposes of mathematical closure. Such differences that are greater than the Relative Positional Accuracy and/or the uncertainty in reference monumentation shall be considered worthy of notice and are therefore discussed further below.

**RELATIVE POSITIONAL ACCURACY**  
The Relative Positional Precision defined by ALTA/NSPS Land Title Survey (Accuracy as defined in IAC 865) (due to random errors in measurement) of the corners of the surveyed property located with this survey are within the specification for an Urban Survey (0.07 feet + 50 parts per million).

**SECTION CORNERS**  
The corners used to perform this survey were the Southeast and Northeast corners of the Northwest Quarter. A Banning capped rebar was located at the southeast corner of said Quarter section. This corner was set during a prior survey for the Town of Plainfield. A 5/8" rebar was located at the northeast corner of said Quarter section. See the survey plat for their locations relative to the computed location of the corner. The estimated uncertainty in the location of these monuments is

two feet on the Northeast corner of the Northwest Quarter and nine feet on the Southeast corner of the Northwest Quarter based on the monuments found and calculations of this survey. These monuments were found near the surface.

**ADDITIONAL MONUMENTS**  
The location of the lines and corners of the surveyed property are dependent upon the geometric data shown and the monuments found, accepted, and/or located with this survey. Those monuments shown with no variation were found to be within 0.3 feet of the computed position and it is my opinion that their variations do not need to be addressed. Additional monuments were located during the course of this survey that aided in the establishment of the parcel lines. Unless otherwise noted, all found and set monuments are in good condition flush with existing grade. Monuments were found at the northeast and southeast corner of the westerly adjoiner. Monuments were found near the east adjoiners. The southern portion of the east adjoiner was purchased and a survey was prepared according to conversations with the home owner. The pipe we found was set with that survey per that conversation.

**THEORY OF LOCATION**  
It is readily apparent that there has been multiple locations of the east line of the Northwest Quarter. This is evidenced by the previous location of a fence found to lie up to 11-12 feet east of the section line. Almost every deed in this area is 6-10 feet closer to the section line than the deed calls out. To add confusion, at some point surveyors utilized the newer location of the east line, which appears to be 6-8 feet west in the area of the survey. Which has caused confusion and ambiguity. On top of these issues, there is a 0.675 mis closure in the writings of the deed.

The west line was located using the previous locations of monuments found along the common southerly line of the parent parcel and the multiple adjoiners. There is 2 feet of uncertainty in the west line at the south and it narrows near the north. The north line was found along the centerline of Main Street, which was located utilizing centerline monuments found. The east line was found to lie along Allen. The Allens said their northwest corner was a rebar found in a pvc set by them. This seem unreliable and so I utilized the 98 feet from the deed along the centerline. The Allen property per Deed Record 254, Page 674 was purchased out of the surveyed property in 1973 per a survey per the Allens. The surveyor set monuments that the Allens had relied on to set posts. So these lines were held. The easterly most line was established as 11.15 north of the Wood Post per the deed angular geometry and trimmed off at the east line of the Quarter Section. The original property may have extended east, but I have no concrete evidence to hold that calculated position and will hold the monuments that control the line. The south line is held along the Right of Way purchased by the Town, which is an exception to the deed. The south line of the parent parcel was held along an ancient fence that was located with both the Hahn survey and previous surveys by Banning Engineering.

**POSSESSION**  
Fences, drives and utilities were found at, along, and near the lines of the surveyed parcel. An asphalt drive crosses the west line. Various utilities lie within or near the right of way of Main Street. The survey and rear walk lie near the east line. Posts were found near the easterly lines. An ancient fence lied along the south line of the parent tract. See the plat of survey for further information about evidence of possession. The location of the fence agreed

**GAPS AND/OR OVERLAPS**  
A deed overlap of nearly 13 feet lies near the easterly lines of the surveyed property.

**UNCERTAINTIES**  
The uncertainties of the survey are shown as follows:  
Availability and condition of reference monuments: 6 feet (previous Banning Survey)  
Occupation or possession lines: 8-10 feet (former location of ancient fence along east line of the quarter section)  
Clarity or ambiguity of record descriptions and/or adjoin descriptions: 0.67 feet

**TITLE COMMITMENT**  
This survey was performed without evidence of source of title for the surveyed property and its adjoiners and is subject to any facts that may be revealed therein.

**FLOOD STATEMENT**  
The surveyed properties is classified as Zone "X" (areas determined to be outside the 0.2% annual chance floodplain) per the Flood Insurance Rate Map (FIRM) for Hendricks County, Indiana, Community Panel Number 18063C0258D, effective date September 25, 2009 Federal Emergency Management Agency, National Flood Insurance Program. Per said FIRM, the surveyed properties do not lie within a Special Flood Hazard Area. The accuracy of any flood hazard statement is subject to map scale uncertainty.

**SURVEYOR'S CERTIFICATE**

I, Jonathan D. Polson, a Registered Land Surveyor in the State of Indiana, hereby state that, to the best of my information, knowledge, and belief, this plat represents a survey completed under my supervision and in accordance with Title 865, Article 1, Chapter 12 of the Indiana Administrative Code.

Date: 4/25/2020  
*Jonathan D. Polson*  
Prepared by: Jonathan D. Polson  
PS No. LS21500011  
State of Indiana

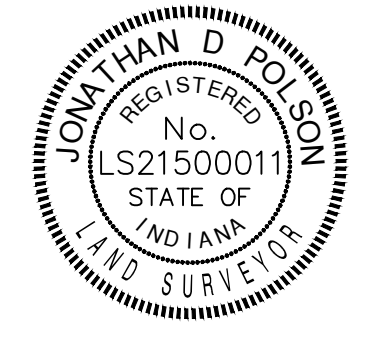

**NOTES:**  
Last day of field work was 4/24/2020 In providing this survey no attempt has been made to obtain or show data concerning the existence, size, depth, condition, capacity or location of any utility existing on the site, whether private, municipal or public owned except as shown otherwise. Subsurface and environmental conditions were not surveyed, examined, or considered as part of this survey. No evidence or statement is made concerning the existence of underground or overhead conditions, containers or facilities that may affect the use or development of this property. Copyright © Banning Engineering, P.C. All rights reserved. No part of this drawing may be reproduced by photocopying, recording or by any other means, or stored, processed or transmitted in or by any computer or other systems without the prior written permission of the surveyor.

As used herein, the word "certify" shall mean an expression of the Consultant's professional opinion to the best of its information, knowledge and belief, and does not constitute a warranty or guarantee by the Consultant.

This instrument was prepared by Jonathan D. Polson, Banning Engineering, 853 Columbia Road, Suite 101, Plainfield, IN 46168.

I affirm, under the penalties of perjury, that I have taken reasonable care to redact each Social Security number in the document, unless required by law. Jonathan D. Polson

Project No:	20107
Sheet No:	1 OF 1
<b>BANNING ENGINEERING</b>	
853 COLUMBIA ROAD, SUITE #101 PLAINFIELD, IN 46168 BUS: (317) 707-3700 FAX: (317) 707-3800 E-MAIL: Banning@BanningEngineering.com WEB: www.BanningEngineering.com	
<b>RETRACEMENT SURVEY</b>	
<b>PREPARED FOR: WADES INVESTMENT, LLC</b>	
<b>PART OF SEC. 34-T15N-R1E</b>	
<b>PLAINFIELD, INDIANA</b>	
Designed:	PS
Drawn:	IDP
Checked:	JDP
Scale:	1" = 40'
Date:	04-20-20







# PLAINFIELD, INDIANA

## TOWN STANDARDS

### DIRECTIONS FOR USE

- 1.) Details Prepared By Outside Sources Shall Not Be Included In The Construction Drawings When Said Details Cover Work Which Is Covered By Town Standards.
- 2.) Individual Town Standards That Do Not Apply May Be Crossed-Out By Design Engineer Through The Placement Of A Single Large X Over The Detail. Minor Reference Notations May Be Placed Adjacent To Individual Standard Titles For Coordination However, The Standards Themselves Shall Not Be Modified In Any Way.
- 3.) Details Prepared By Outside Sources Covering Work Which Is Not Covered By Town Standards Are The Sole Responsibility Of The Design Engineer And Shall Be Placed On Sheets Other Than The Town Standards Sheets.
- 4.) Failure To Properly Execute The Above Directions For Use Will Not Effect The Applicability Nor The Enforcement Of The Town Standards.
- 5.) Town Of Plainfield Shall Be Contacted When Required By Calling 317-839-3490.

### GENERAL NOTES

- 1.) Contractor Shall Verify The Exact Location Of All Existing Utilities At Least 24 Hours Prior To Any Construction Or Excavation. During Construction, All Utilities Shall Be Adequately Supported To Minimize Damage. The Contractor Shall Be Responsible For Repairing Or Replacing Damaged Utilities To The Satisfaction Of The Town Of Plainfield And The Owner Of The Affected Utility.
- 2.) Installation Of Or Provisions For The Installation Of All Underground Utilities (Including Service Laterals) To Be Placed Under Pavement Areas Shall Be Established Prior To The Construction Of The Pavement. The Town Reserves The Right To Require Trenchless Construction For Crossing Of Existing Streets.
- 3.) All Benchmarks And Elevations Shall Be U.S.C. & G.S. Datum.
- 4.) Wherever Proprietary Equipment Is Specified, All Proposals For Substitution Shall Be Submitted In Writing To The Plainfield DPW And Shall Be Subject To The Findings Of The Plainfield DPW.
- 5.) Whenever A Non-Parallel Trench Opening Encroaches Within 5' Of An Existing Street Or Whenever Centerline Of Water Main Is Within 3' Of An Existing Street, Flowable Fill Shall Be Used For Trench Backfill.
- 6.) Except For Water Main Construction, Whenever A Non-Parallel Trench Opening Encroaches Within 5' Of A Proposed Street, Private Drive Or Sidewalk, Granular Backfill If Testing Confirms Compaction. #8 Crushed Stone, #8 Fractured Face Aggregate Or Flowable Fill Shall Be Used For Trench Backfill.
- 7.) For Water Main Parallel With Adjacent Pavement And Having A Centerline Of Pipe At Least 3' Behind Back-Of-Curb, Approved Backfill Material May Be Used For Trench Backfill. Whenever Centerline Of Water Main Encroaches Within 3' Of A Proposed Street, Private Drive Or Sidewalk, #8 Crushed Stone, #8 Fractured Face Aggregate, Or Flowable Fill Shall Be Used For Trench Backfill.
- 8.) Approved Excavated Material May Be Used For Backfill Outside Of Limits Specified Herein And Under Proposed Sidewalks Provided Sidewalks Are Constructed 6 Months After Backfilling Of Trench. In Order For Excavated Material To Be Approved For Backfill It Shall Be Free Of Organic Material, Rocks Larger Than 6 Inches, Frozen Material, Debris, Excessive Water, Or Other Unsuitable Material As Determined By Plainfield DPW.
- 9.) Black Foundry Sand Is NOT Approved For Use In The Town Of Plainfield.
- 10.) Whenever Granular Backfill Is Placed In A Trench, Contractor Shall Compact Material To A Minimum Of 95% Maximum Dry Density As Per AASHTO T99. The Contractor Shall Demonstrate That Compaction Is Achieved By Means Of In Place Density Tests Performed By An Independent Testing Firm. Testing Frequency Shall Be One Test Per Trench Or 1 Test Per 100 Linear Feet Of Trench, Whichever Is Greater.
- 11.) In Order To Mitigate The Impact Of Land Disturbing Activities On The Public, The Town Currently Allows Two Options. Option 1: Preparation, Implementation, & Maintenance Of A Lime Stabilization Plan For Building Area, Activity Area Adjacent To Building, Access Road(s), & Staging Area Utilizing A Minimum Of 4" Of CAB No. 53 Over A Minimum Of 8" Thickness Lime Subgrade Treatment. Option 2: Preparation, Implementation, & Maintenance Of A Sufficient Washbay Area. If Option 2 Is Deemed Insufficient At The Sole Discretion Of The Town Engineer, Option 1 Will Need To Be Implemented Prior To Any Other Construction Activity Proceeding At The Site.
- 12.) The Construction Of New Combined Sewers Within The Town Of Plainfield's Service Area Is Prohibited. New Construction That Is Tributary To An Existing Combined Sewer Shall Be Designed To Minimize Or Delay The Inflow Contribution To The Existing Combined Sewer. Where New Construction Is Served By Existing Combined Sewers, The Inflow/Clear Water Connection To The Existing Combined Sewer Shall Be Made Separate And Distinct From The Sanitary Waste Connection To Facilitate Disconnection Of The Former If A Separate Storm Sewer Subsequently Becomes Available.

Town Standards Apply To Public Property & Private Property.

The Entire Set Of Full Size Town Standards Shall Be Attached To The Construction Drawings And Shall Be Considered Part Thereto.

**DATE OF CURRENT ISSUANCE: 01/01/2019**

INDEX	
SHEET NO.	DESCRIPTION
1	DIRECTIONS FOR USE, GENERAL NOTES
2	RIGHT-OF-WAY, UTILITY EASEMENT & UTILITY LOCATION GUIDELINES
3	PAVEMENT, CURB & SIDEWALK DETAILS & NOTES
4	ROADWAY (R) DEVELOPMENT STANDARDS
5	BUS SHELTER DETAILS AND MISCELLANEOUS DETAILS
6	MISCELLANEOUS DETAILS AND NOTES
7	GENERAL (G) DEVELOPMENT STANDARDS
8	STORM SEWER BEDDING DETAILS AND NOTES
9	STORM SEWER DETAILS AND NOTES
10	STORM DRAINAGE (D) DEVELOPMENT STANDARDS
11	WATER MAIN BEDDING DETAILS & NOTES
12	WATER MAIN DETAILS & NOTES
13	WATER (W) DEVELOPMENT STANDARDS
14	SANITARY SEWER BEDDING DETAILS AND NOTES
15	SANITARY SEWER DETAILS AND NOTES
16	SANITARY SEWER LIFT STATION STANDARDS & GUIDELINES
17	SANITARY SEWER (S) DEVELOPMENT STANDARDS
18	SANITARY SEWER (S) DEVELOPMENT STANDARDS
19-21	EROSION CONTROL MEASURES & EROSION CONTROL (E) DEVELOPMENT STANDARDS
22	LOW SPEED URBAN / SUBURBAN ROUNDABOUT DETAIL
23	STREET LIGHTING DETAILS
24	TRAFFIC SIGNAL DETAILS
25	WIRELESS DETECTION DETAILS



REVISIONS		
Rev. No.	Description	Date

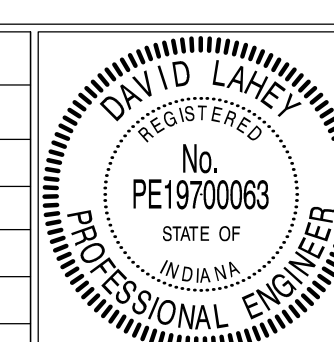

RECOMMENDED FOR APPROVAL	<i>David Lahey</i>	DESIGN ENGINEER	01/01/2019	DATE
APPROVED	<i>Samuel...</i>	TOWN ENGINEER	01/01/2019	DATE
APPROVED	<i>John...</i>	DIRECTOR OF TRANSPORTATION	01/01/2019	DATE

TOWN OF PLAINFIELD	SHEET
DIRECTIONS FOR USE, GENERAL NOTES	01 OF 25

**GENERAL NOTES**

- 1.) The Right-Of-Way Widths, Pavement Widths, And Easement Widths Indicated On This Sheet Are Minimum Distances Required By The Town Of Plainfield. Greater Widths May Be Provided. The Contractor Shall Review The Plat And The Plans To Confirm The Various Widths Indicated On This Sheet And Shall Report Any Discrepancy To The Town Engineer Prior To Proceeding With Construction.
- 2.) The Location Of Proposed Utilities As Indicated Hereon Are Based Upon The Experience Of The Town Of Plainfield And Are So Indicated To Ensure The Orderly Development Of The Land. Strict Adherence To The Indicated Location Is Required. Requests To Change The Location Of The Proposed Utilities Shall Be Submitted In Writing To The Town Engineer And The Superintendent Of Public Works. Utilities Not Meeting These Requirements Shall Be Removed And Replaced As Directed By The Town Engineer.
- 3.) Arterial Streets And Divided Arterial Streets Are To Be Coordinated With The Town Engineer And Shall Be In Accordance With The Minimum Design Standards Outlined By The Subdivision Control Ordinance.
- 4.) Local Residential Streets Require Only Stop Bars And Crosswalk Marking. Markings Shall Be Thermoplastic In Accordance With The Most Recent INDOT Standard Specification. Refer To Such Drawings Covering Pavement Markings, Street Signs, And Traffic Control Signs. A Plan Of Proposed Pavement Markings Shall Be Submitted To The Plainfield DPW For Approval. For Streets Requiring Resurfacing With Surface Overlay, Mill 8 Feet Wide Along Sides Of Street To A Depth Of 2". Overlay Terminations Shall Also Be Milled 2".
- 5.) Vertical Curves Of A Minimum Length Of 20 Feet Shall Be Provided At All Grade Changes In Accordance With The Town Of Plainfield Subdivision Control Ordinance. For Phased Development, The Vertical Curve Shall Be Constructed To The EVC.

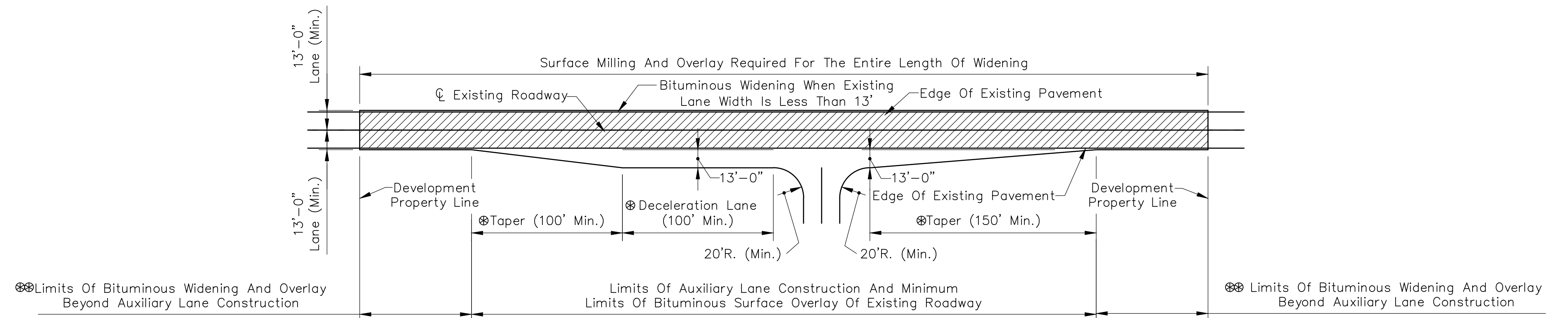

NOTES:  
 ⊕ Taper and Deceleration Lane Length Shall Be Designed Based Upon Design Speed Of Existing Roadway  
 ⊕ Bituminous Widening And Overlay Required When Development's Frontage Extends Beyond The Limits Of The Auxiliary Lane Construction

**AUXILIARY LANE CONSTRUCTION**

Scale: 1/4" = 1'-0"

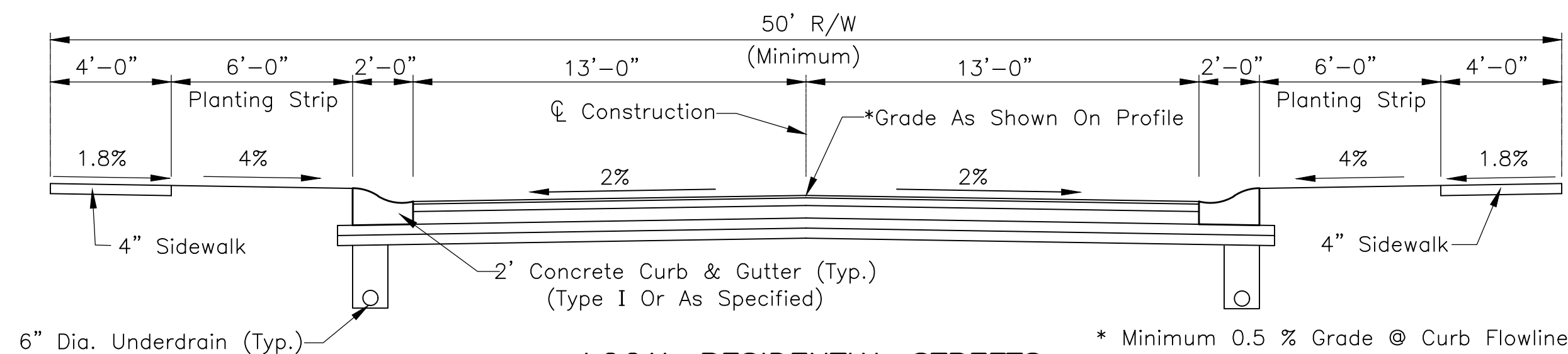

**LOCAL RESIDENTIAL STREETS**

Scale: 1/4" = 1'-0"

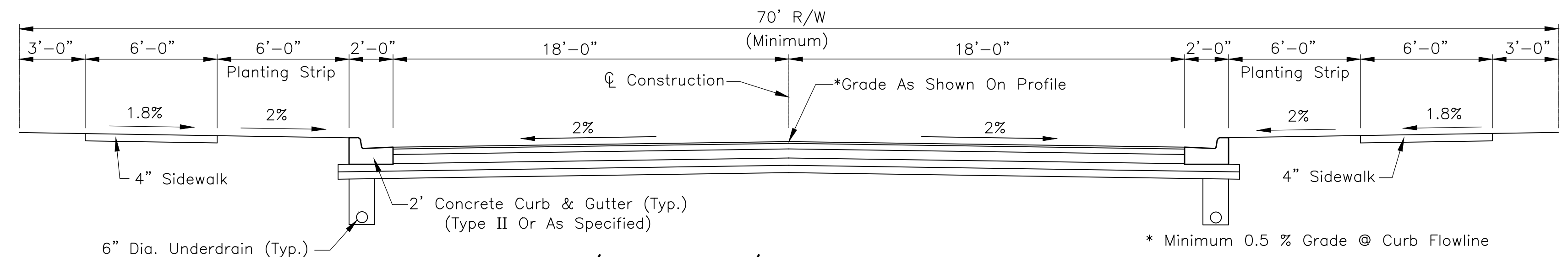

**RESIDENTIAL/COMMERCIAL/INDUSTRIAL COLLECTOR STREETS**

Scale: 1/4" = 1'-0"

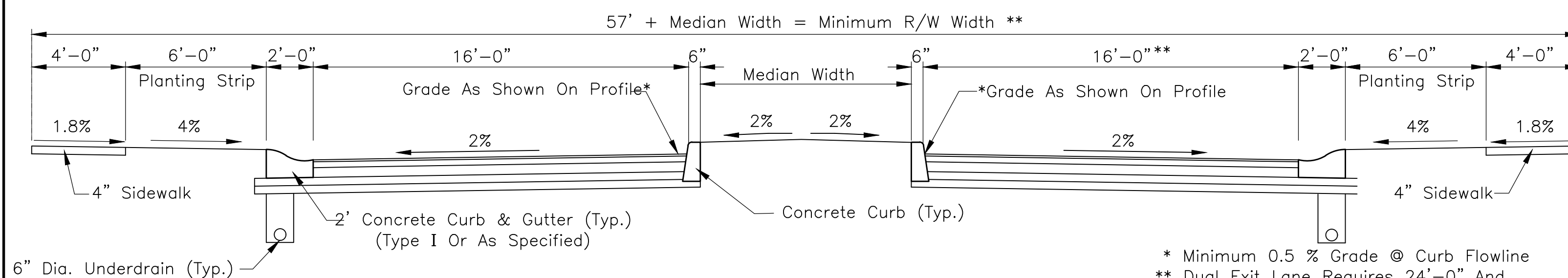

**LOCAL RESIDENTIAL STREETS ENTRY MEDIAN DETAIL**

Scale: 1/4" = 1'-0"

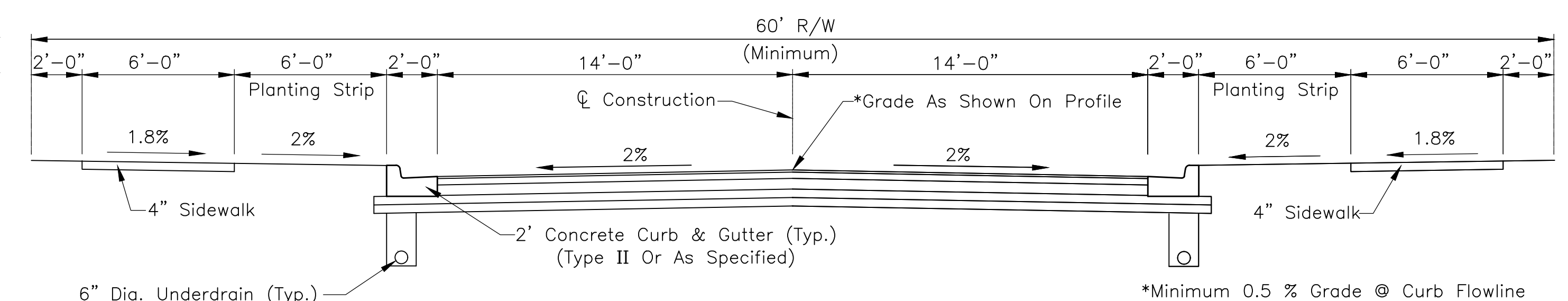

**LOCAL INDUSTRIAL STREETS**

Scale: 1/4" = 1'-0"

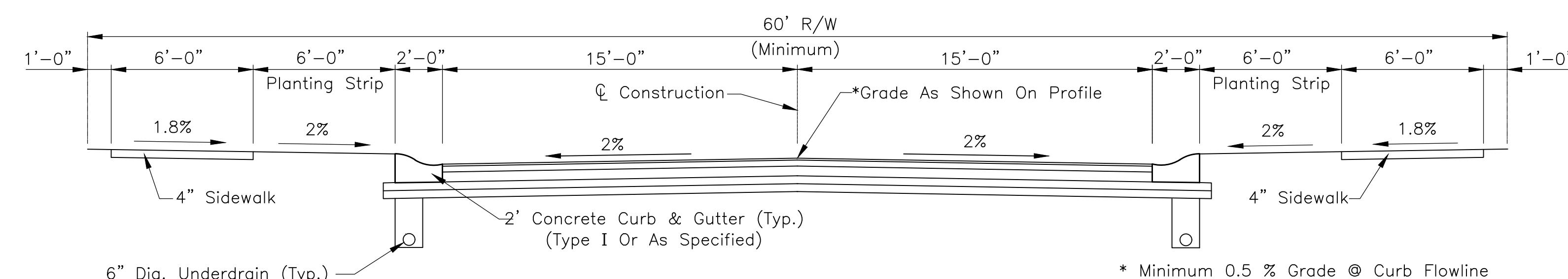

**LOCAL RESIDENTIAL COLLECTOR STREETS**

Scale: 1/4" = 1'-0"

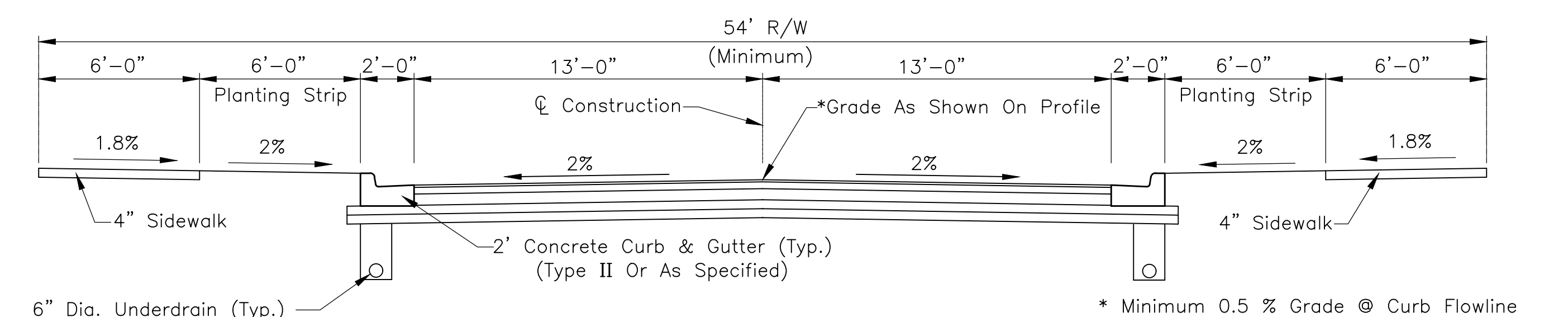

**LOCAL COMMERCIAL STREETS**

Scale: 1/4" = 1'-0"

REVISIONS		
Rev. No.	Description	Date

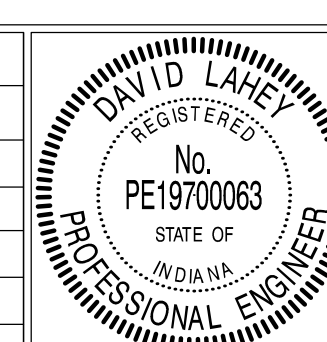

RECOMMENDED FOR APPROVAL: *David Lahey* DESIGN ENGINEER 01/01/2019 DATE

APPROVED: *Samuel...* TOWN ENGINEER 01/01/2019 DATE

APPROVED: *Jared...* DIRECTOR OF TRANSPORTATION 01/01/2019 DATE

TOWN OF PLAINFIELD  
 RIGHT-OF-WAY,  
 UTILITY EASEMENT & UTILITY LOCATION  
 GUIDELINES

SHEET  
 02  
 OF  
 25



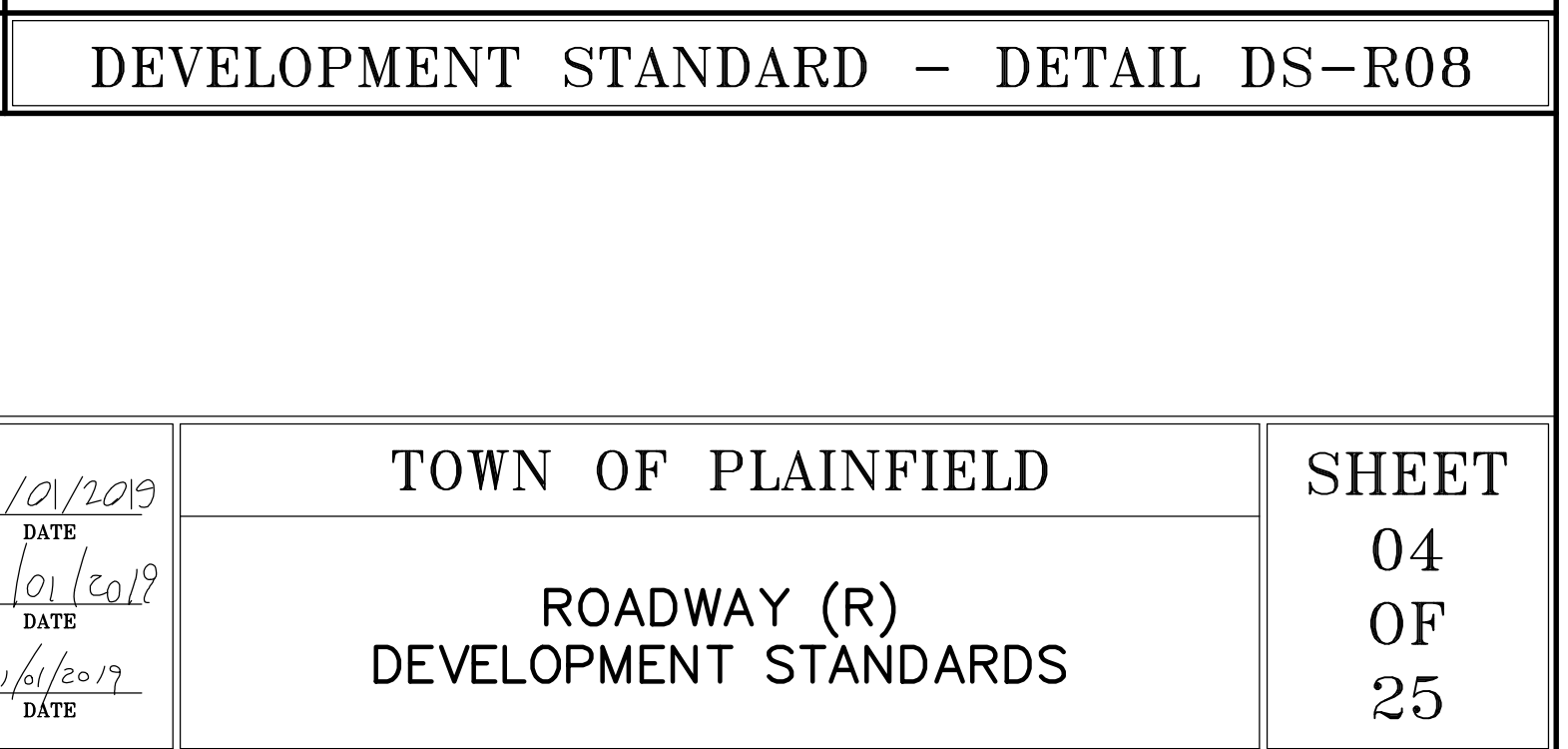
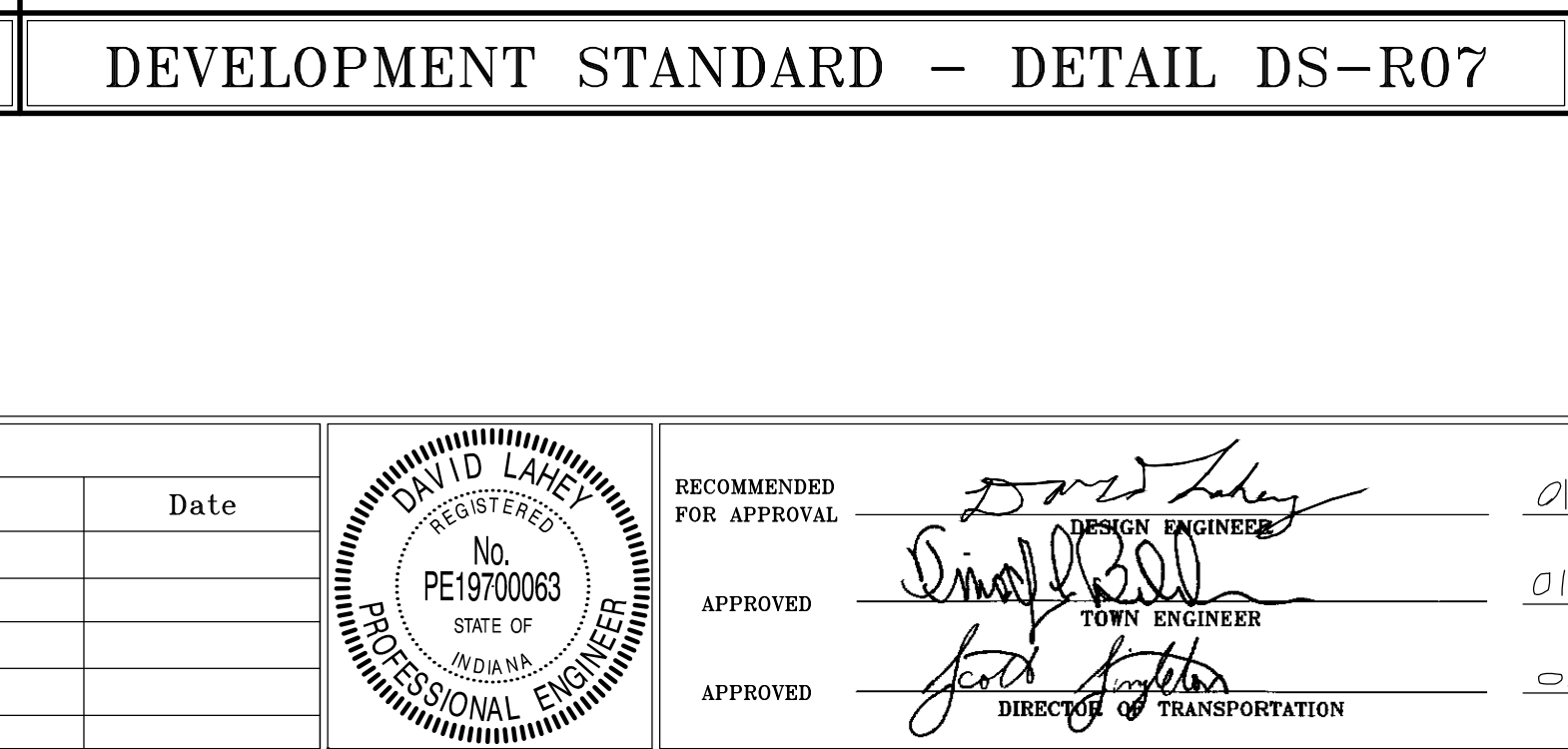
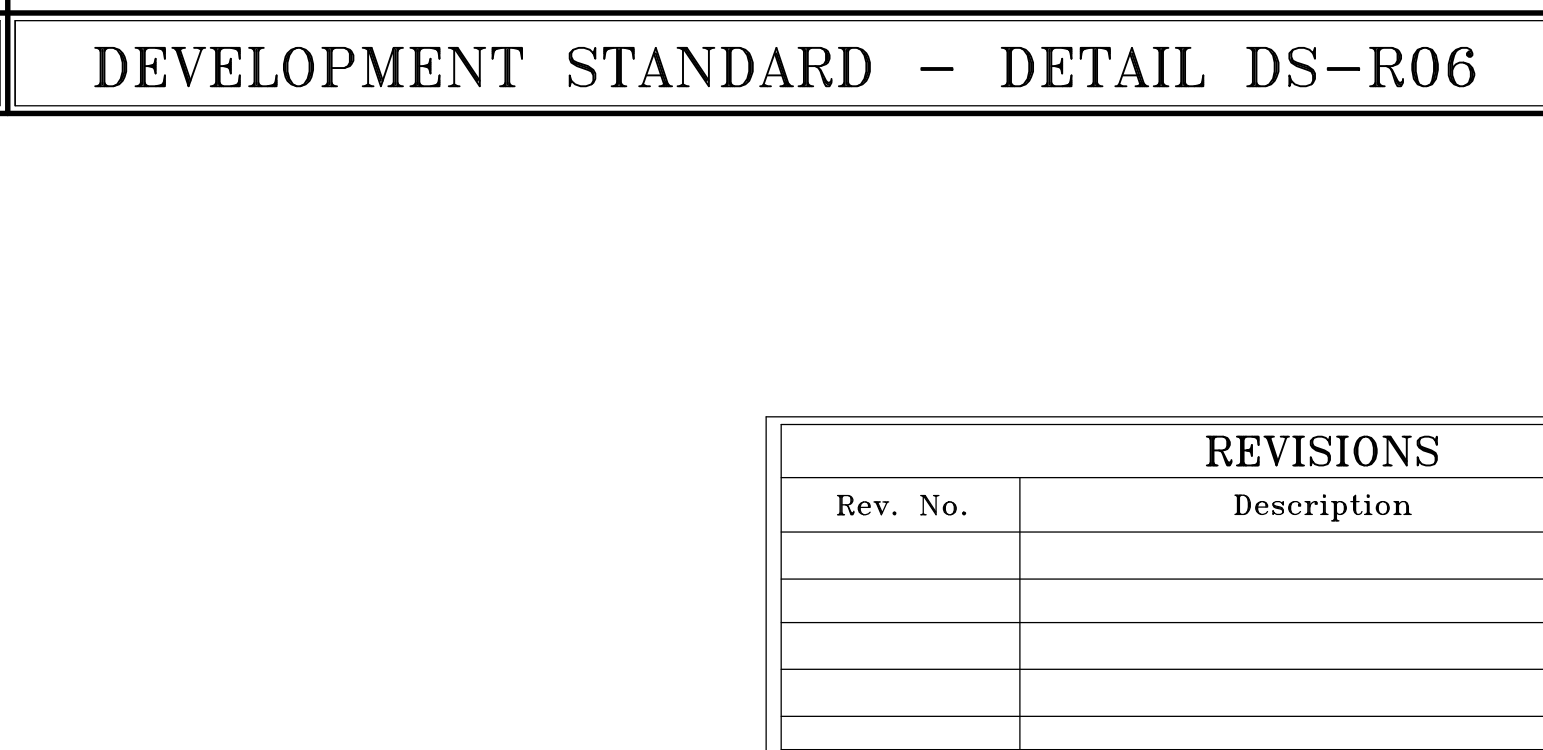
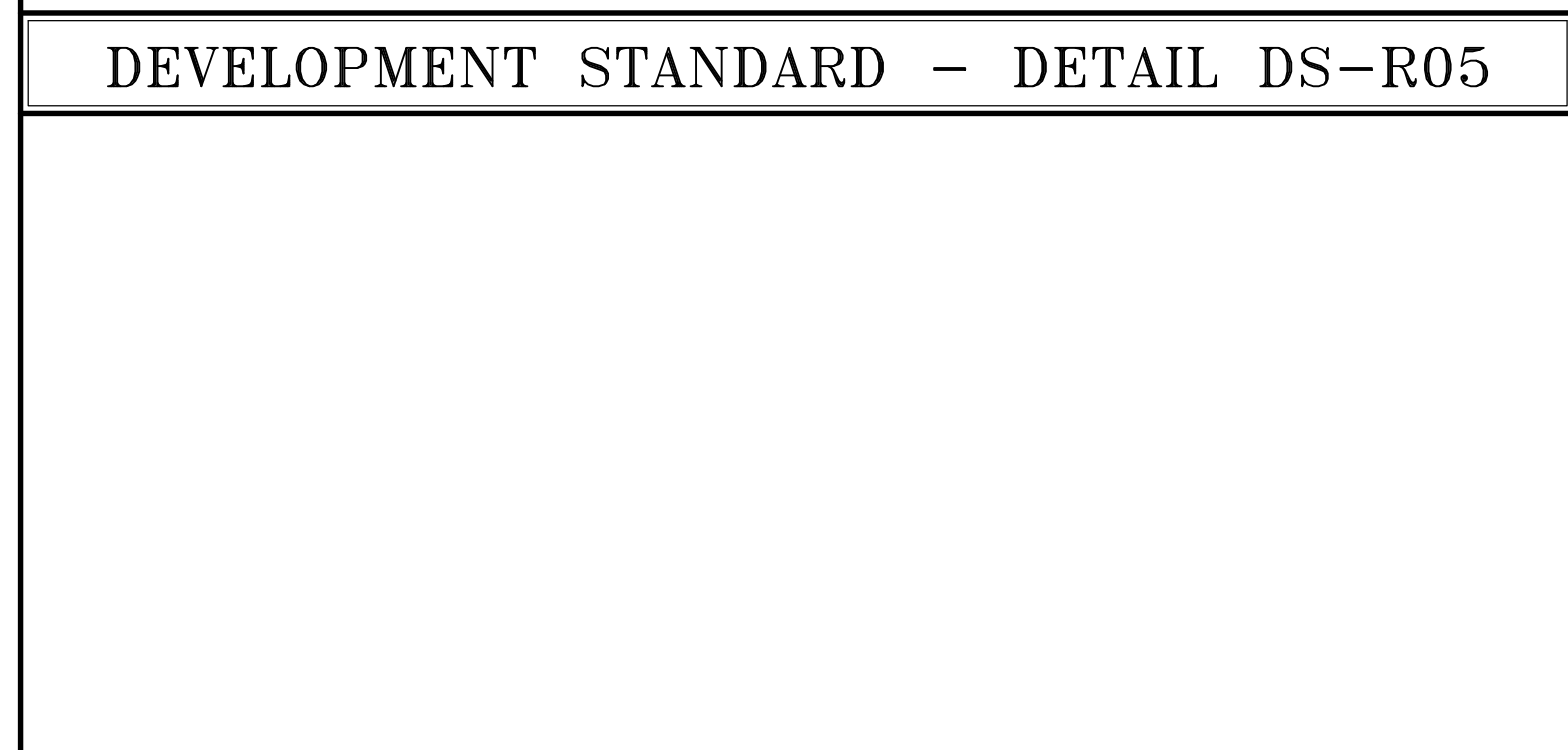
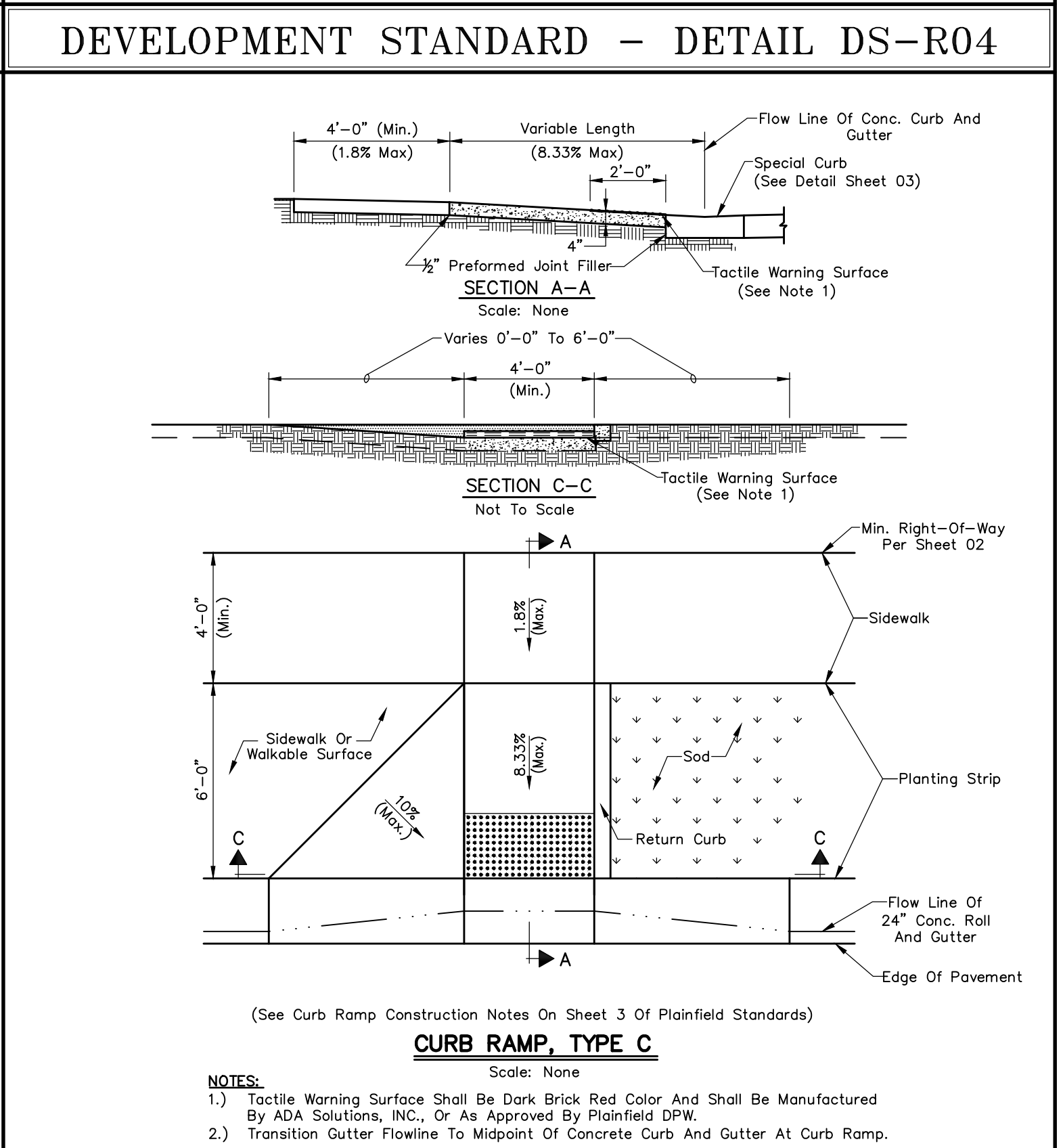
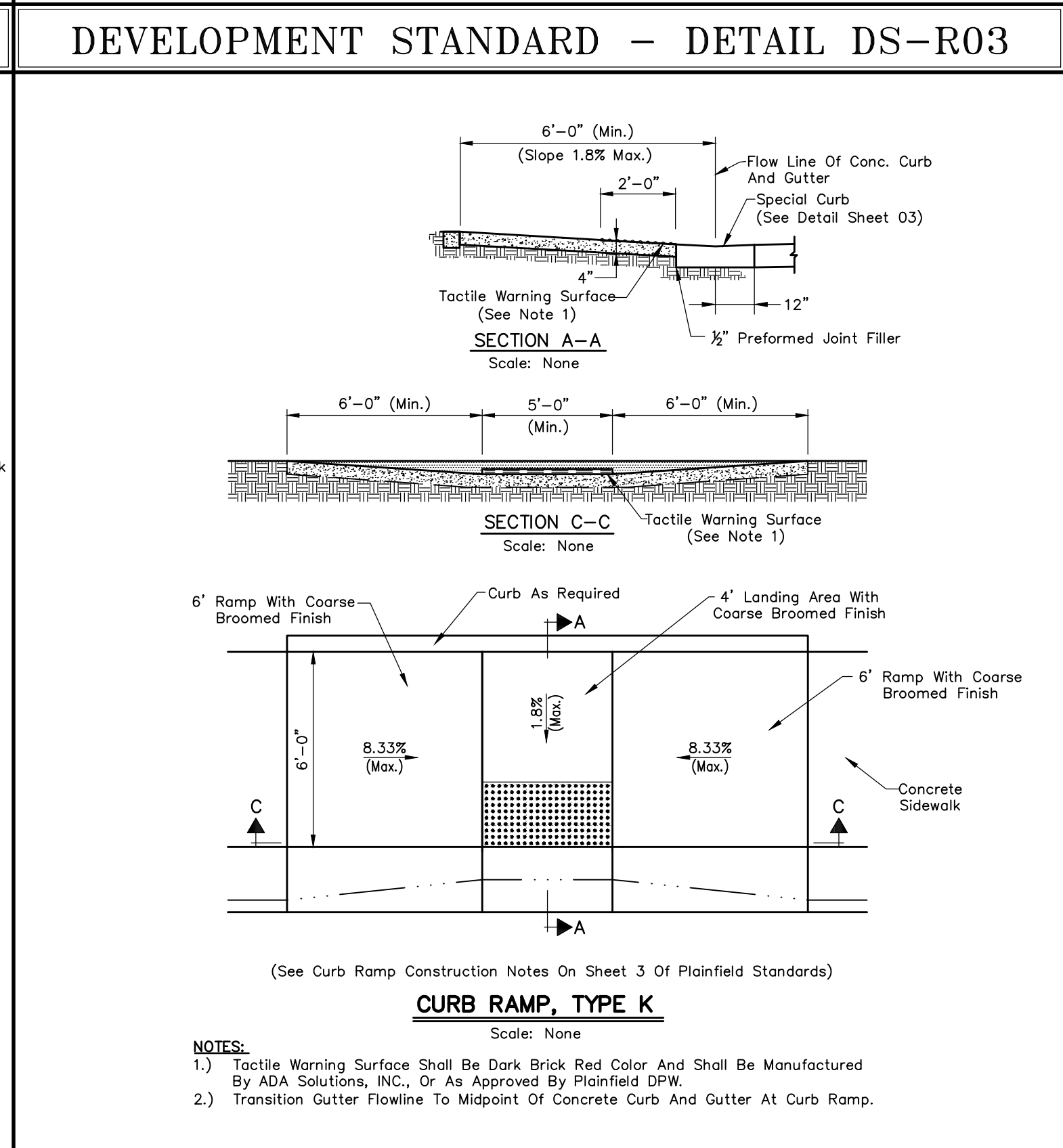
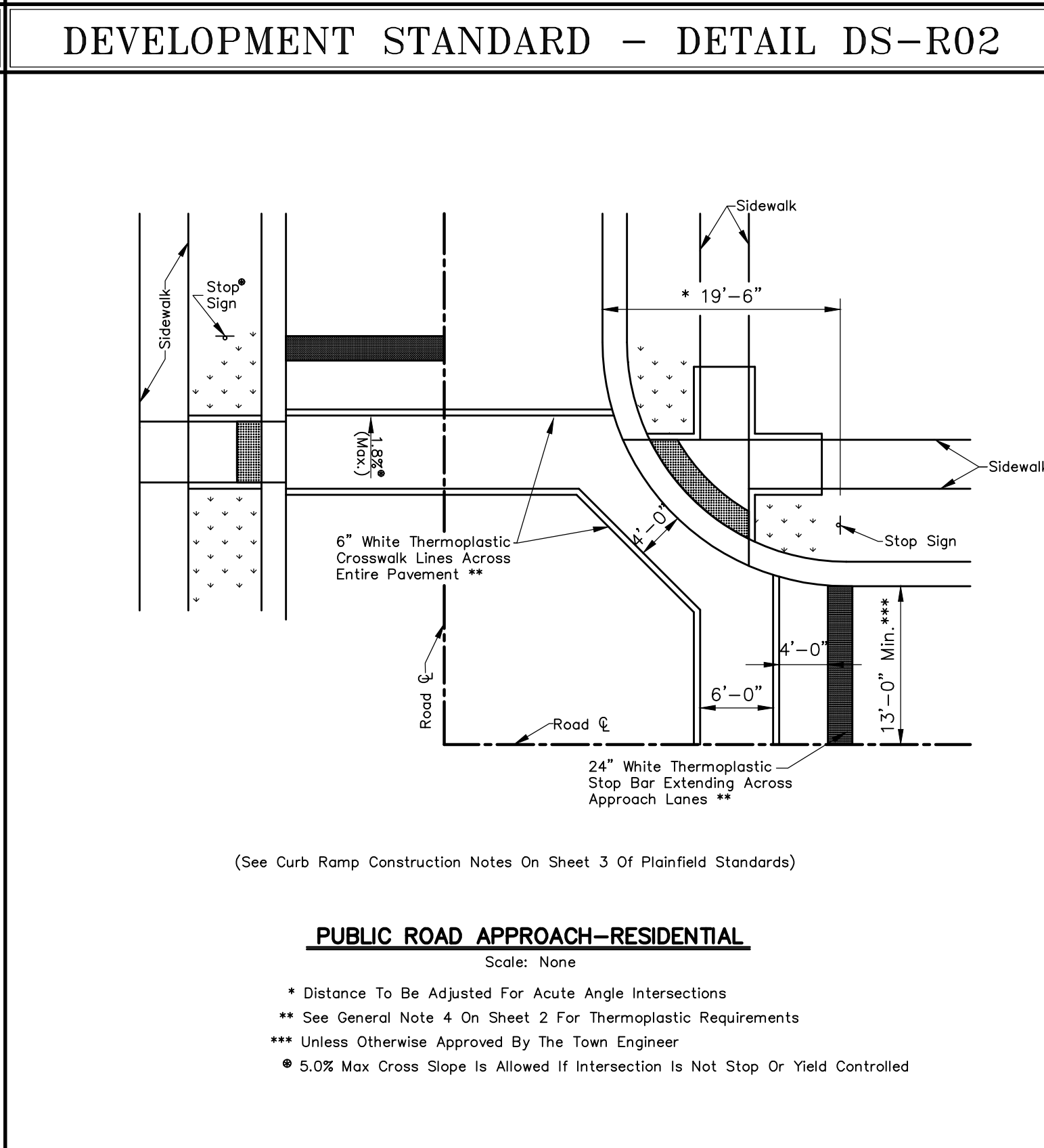
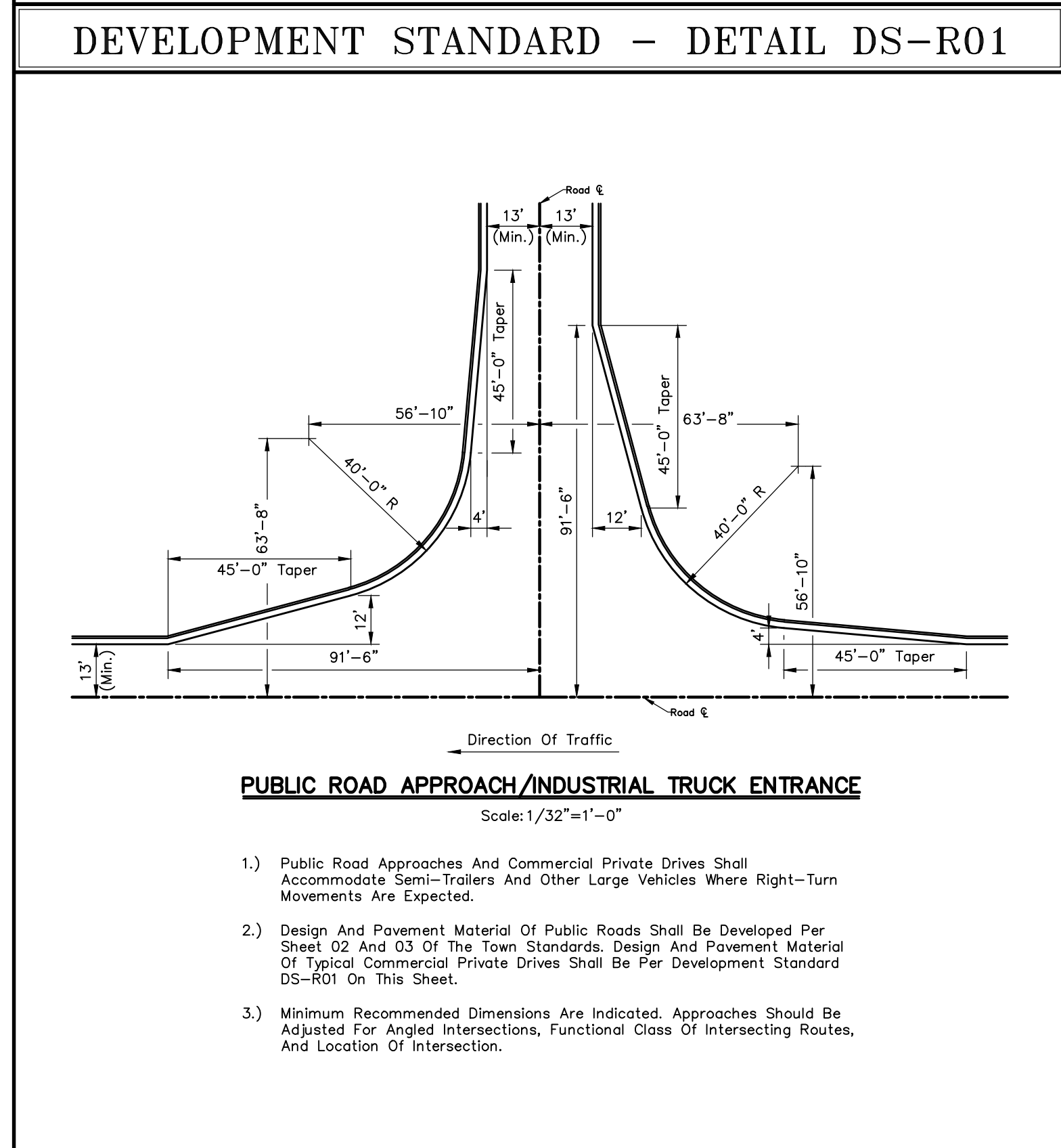
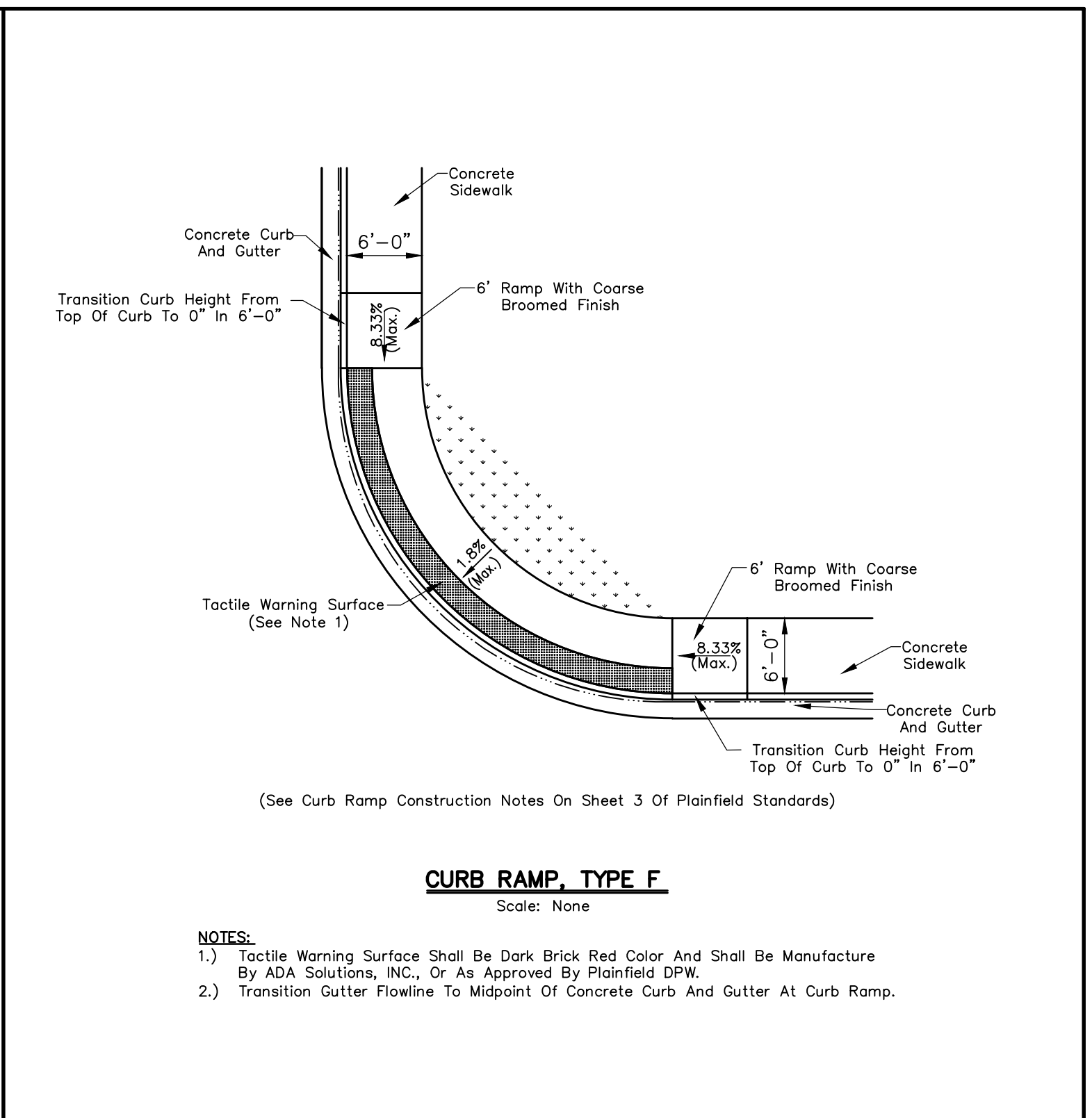
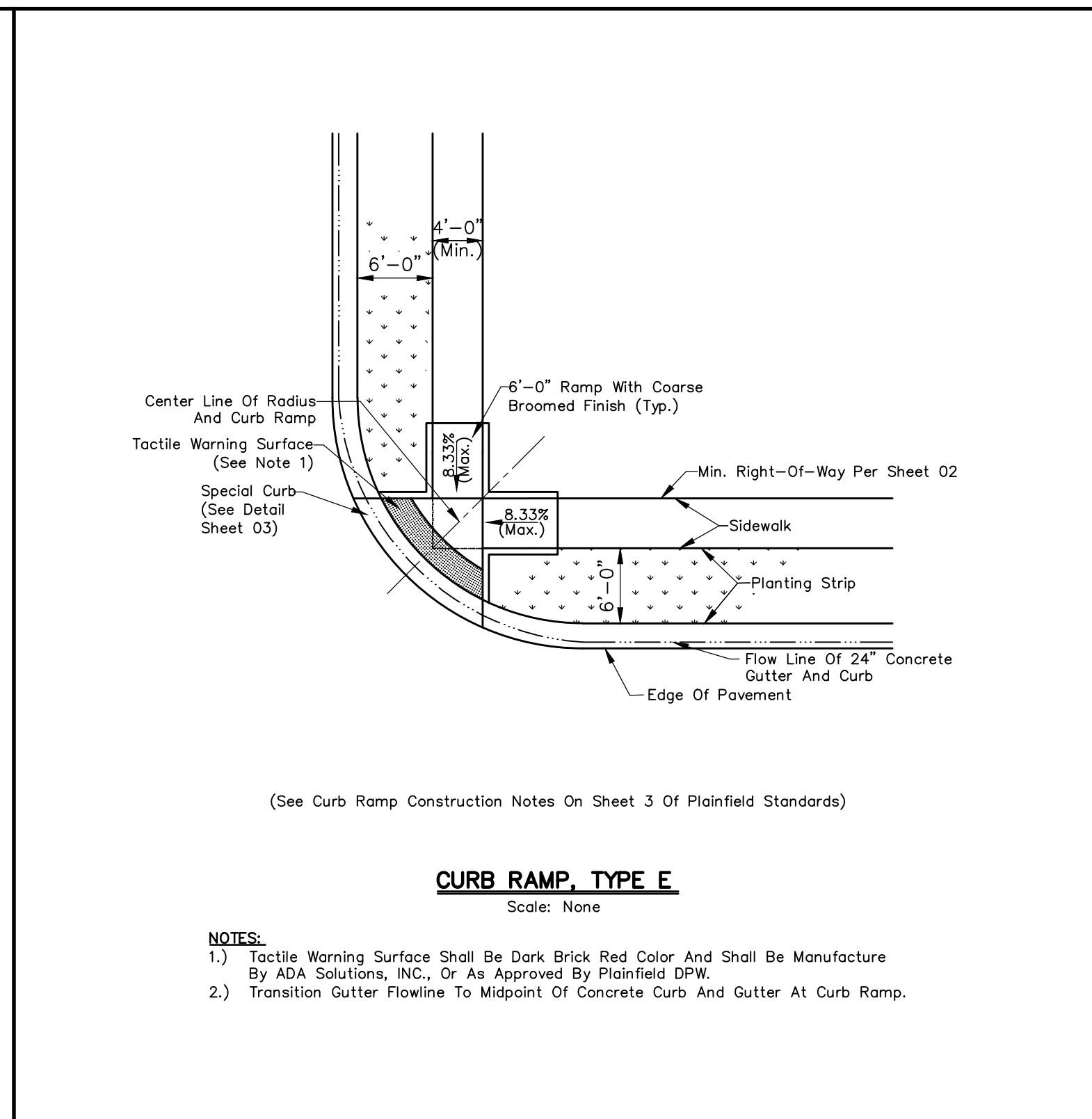
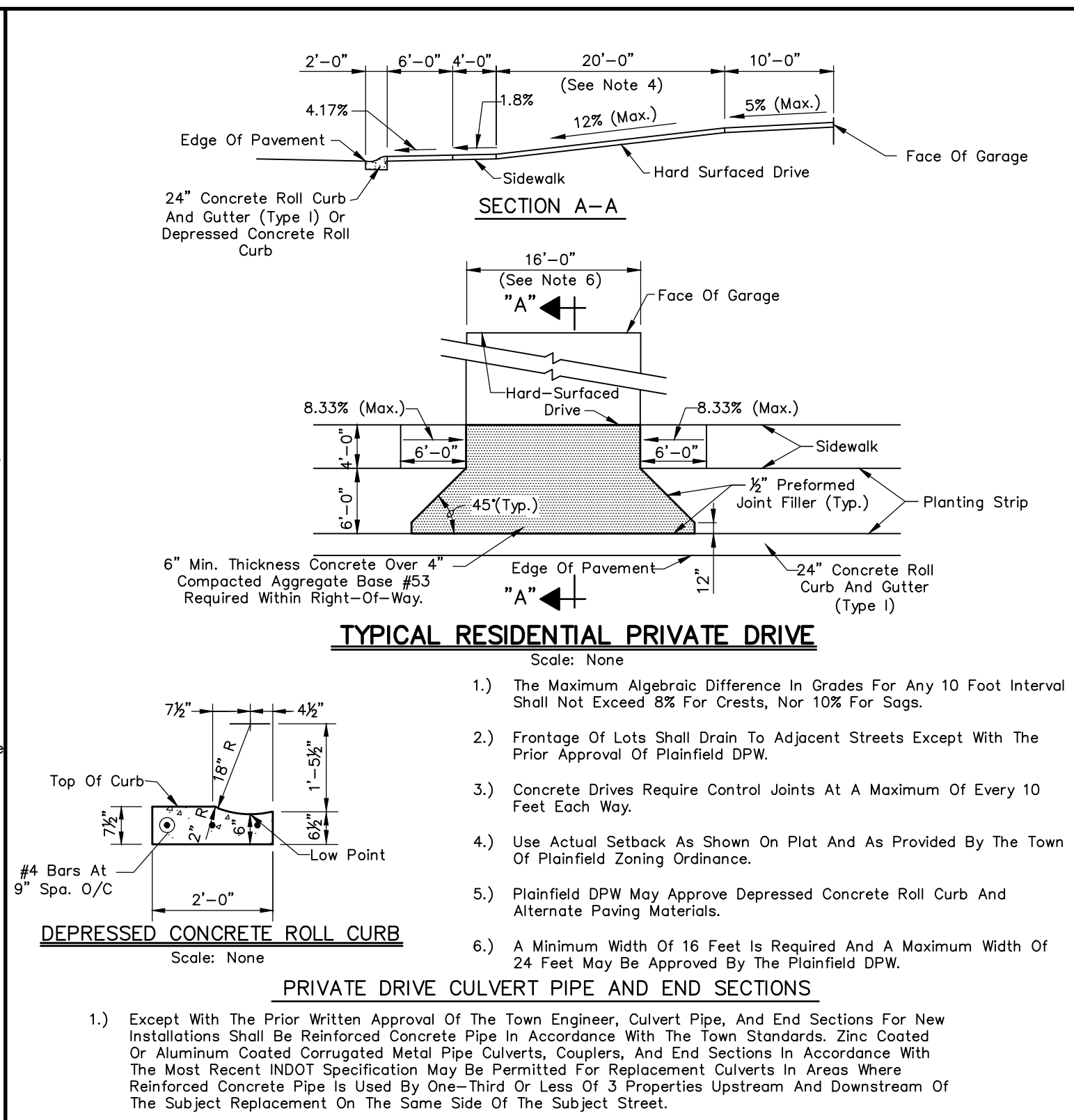
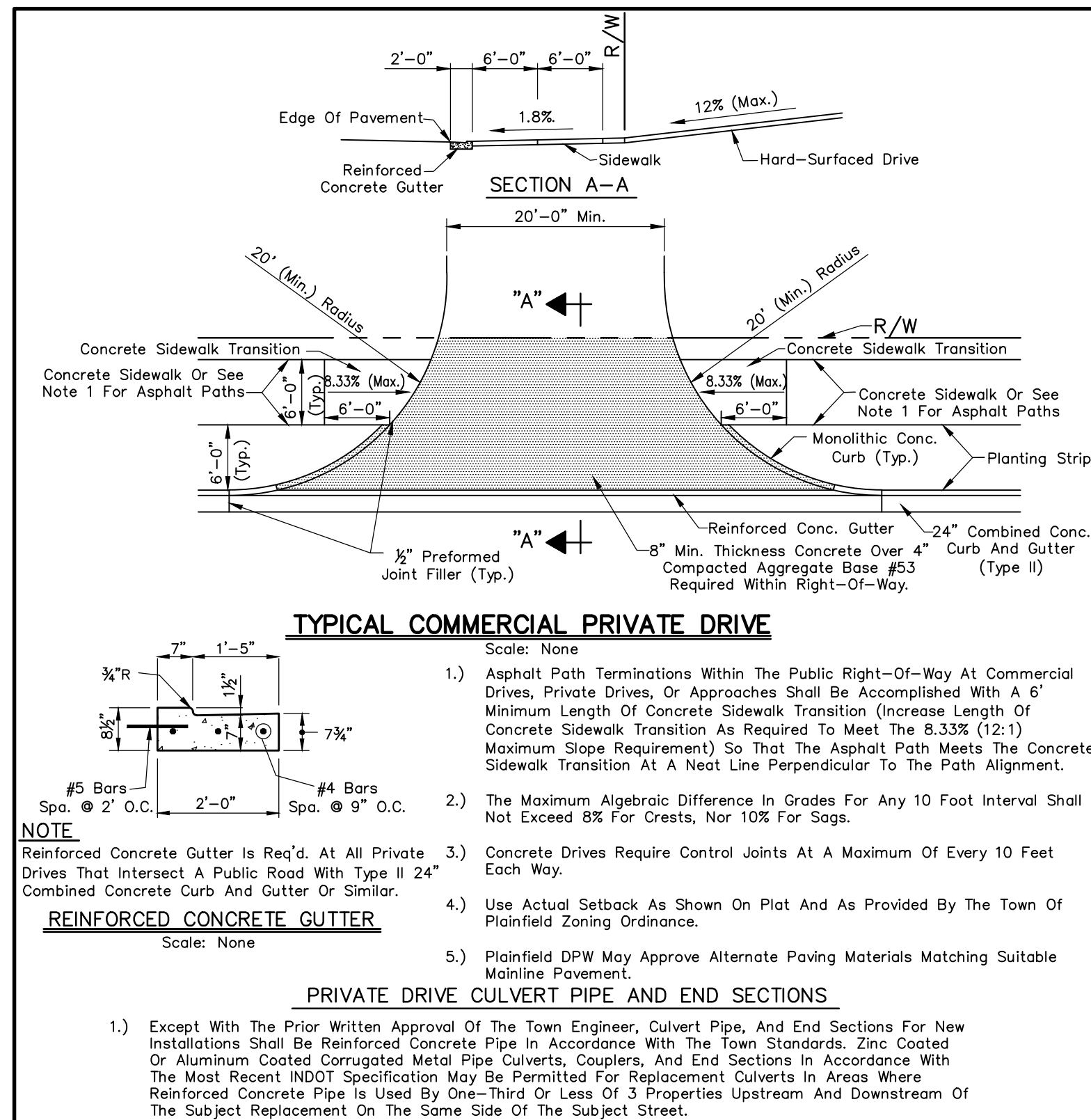

REVISIONS		
Rev. No.	Description	Date

RECOMMENDED FOR APPROVAL: *David Laney* DESIGN ENGINEER 01/01/2019 DATE

APPROVED: *Samuel...* TOWN ENGINEER 01/01/2019 DATE

APPROVED: *Jana...* DIRECTOR OF TRANSPORTATION 01/01/2019 DATE

TOWN OF PLAINFIELD

ROADWAY (R) DEVELOPMENT STANDARDS

SHEET 04 OF 25

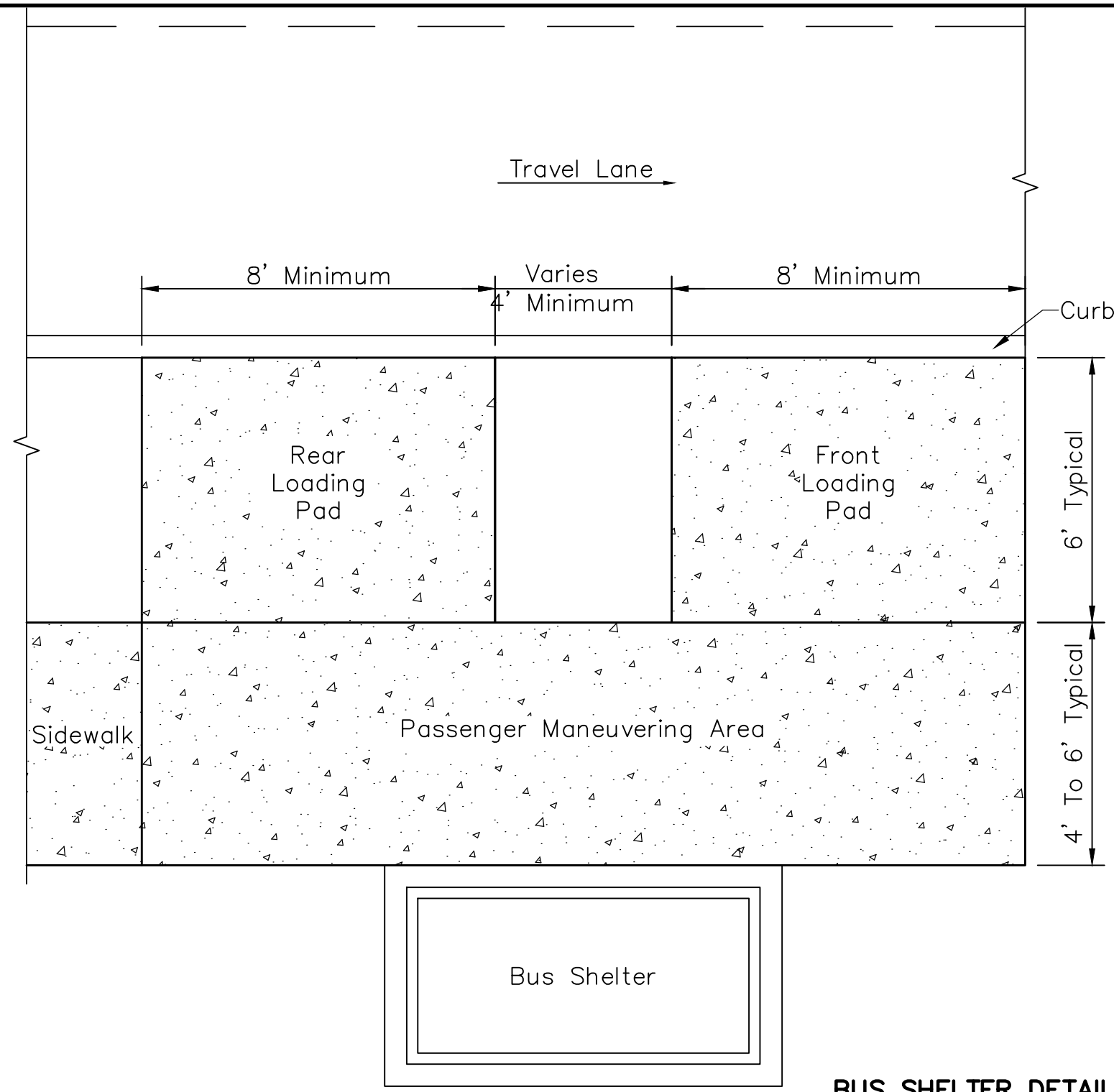

**BUS SHELTER DETAIL**  
Not To Scale

**Bus Shelter Location And Pad Notes:**

1. Shelters Shall Be Located A Minimum Of 100 Feet From Any Intersection Measured Mid-Radius From The Intersection Curb Subject To Town Review.
2. The Shelter Opening Shall Be Oriented Toward The Passenger Maneuvering Area.
3. Loading Pads And Passenger Maneuvering Area Shall Be 4 Inches Of Concrete On Top Of 4 Inches Of Compacted Aggregate Base, No. 53.
4. The Pad For The Bus Shelter Shall Be A Minimum Of 1 Foot Wider And 1 Foot Longer Than The Dimensions Of The Bus Shelter. The Pad Shall Be Engineered Per Manufacturer's Recommendations Based Upon The Sizing Of The Shelter.

**Bus Shelter Notes:**

1. Shelter And Wall Accessories Shall Be The Slimline Arched Model As Manufactured By Brasco International Or A Town Approved Equal. Shelters Shall Be Engineered By The Manufacturer To Meet Wind, Snow, And Seismic Loadings. Shelters May Vary In Size Between 4 Feet Wide By 8 Feet Long and 6 Feet Wide By 18 Feet Long Depending On The Amount Of Passengers Estimated At An Individual Stop.
2. Shelter Frame Shall Be Powder Coated Signal Gray (RAL 7004).
3. Shelter Roof Shall Be Shed Style With A Minimum 6 Inches Of Overhang Past The Opening, Acrylic, And Shall Be Signal White (RAL 9003).
4. Shelter Wall Panels Shall Be Glass. Shelter Wall Side Wall Panels Shall Include The Plainfield "P" Logo Ceramic Baked Into The Glass. An Advertisement Box May Be Included As One Of The Shelter Wall Panels.
5. Shelters Shall Be Provided With Wall Mount Benches On The Interior Of All Walls. Wall Mount Benches Shall Be Powder Coated Signal Gray (RAL 7004).
6. Shelters Shall Include A Solar Powered Lighting Package And Wall-Mounted Map Case.
7. A Signal White (RAL 9003) 'Stop Name' Plate With Luminous Bright Red (RAL 3026) Lettering Shall Be Provided On The Front Of The Shelter.

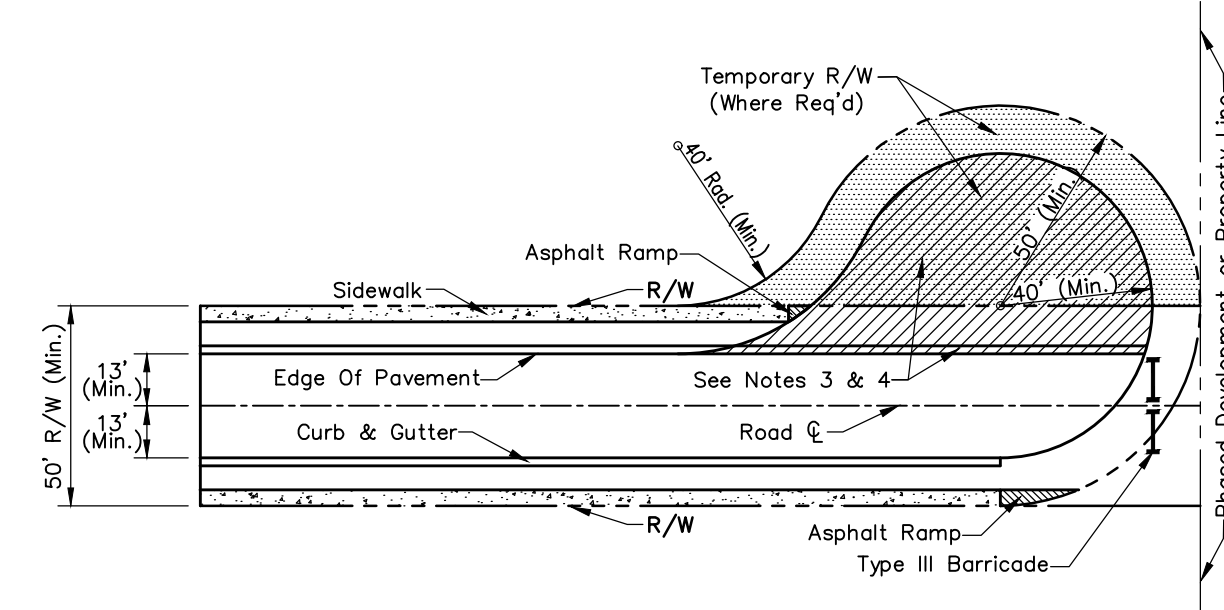

**TEMPORARY CUL-DE-SAC**  
Scale: None

1. When Streets Are Temporarily Dead-End, A Temporary Cul-De-Sac Shall Be Constructed. Permanently Dead-End Streets Are Prohibited By The Subdivision Control Ordinance.
2. Right-Of-Way And Back-Of-Curb Diameter Shall Be In Conformance With The Minimum Design Standards For Streets In The Subdivision Control Ordinance.
3. For Residential Streets, Continue Proposed Pavement and Curb Through The Temporary Cul-De-Sac To The End Of Pavement. Concrete Roll Curb & Gutter Shall Be Used Through The Temporary Cul-De-Sac And Mainline Pavement Shall Be Used Beyond The Proposed Curb And Gutter.
4. For Industrial Streets, Continue Proposed Pavement Through The Temporary Cul-De-Sac. Extending Concrete Roll Curb & Gutter Through The Temporary Cul-De-Sac Is Optional. 8" Of INDOT No. 2 Stone May Be Used Throughout The Temporary Cul-De-Sac.
5. Typical Cross Slope To Be Maintained Through The Temporary Cul-De-Sac And Temporary Drainage Should Be Provided.

DEVELOPMENT STANDARD - DETAIL DS-R09

DEVELOPMENT STANDARD - DETAIL DS-R10

REVISIONS		
Rev. No.	Description	Date

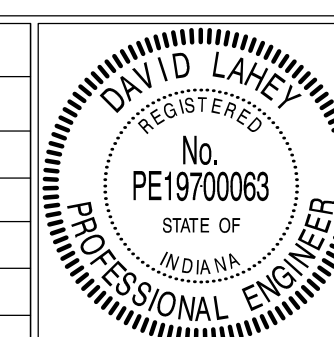

RECOMMENDED FOR APPROVAL: *David Laney* DESIGN ENGINEER 01/01/2019 DATE

APPROVED: *Samuel...* TOWN ENGINEER 01/01/2019 DATE

APPROVED: *John...* DIRECTOR OF TRANSPORTATION 01/01/2019 DATE

TOWN OF PLAINFIELD

BUS SHELTER DETAILS & MISCELLANEOUS DETAILS

SHEET 05 OF 25

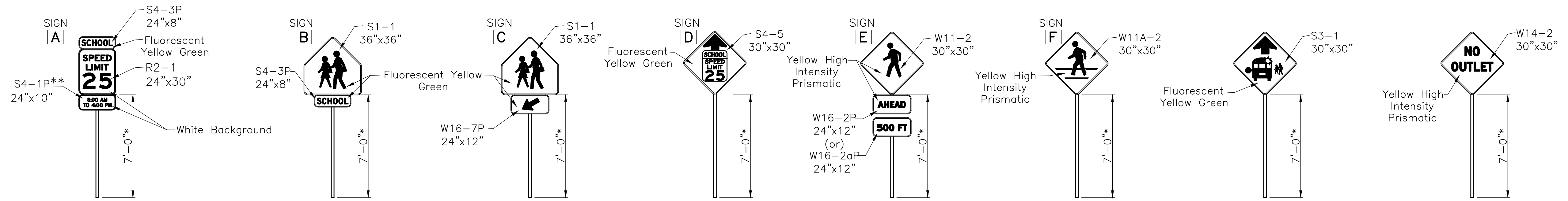

- NOTES:**
- \*) Mounting Height From Roadway Edge Of Pavement. (Typ. 2.)
  - \*\*) Confirm Times With Plainfield DPW
  - All Black Lettering Is Scotchlite 7720 (Or Equal)

**REGULATORY/WARNING SIGN DETAILS**

Scale: 3/16" = 1'-0"

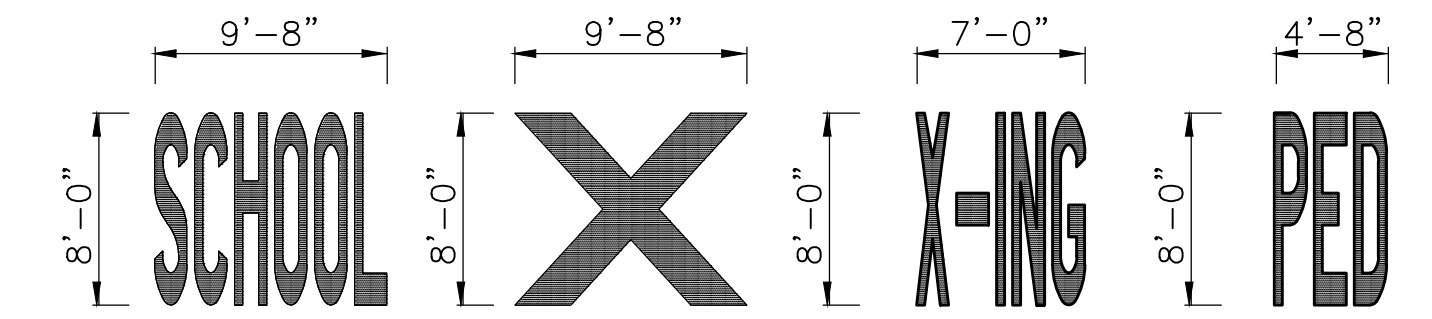

**PAVEMENT MARKING DETAIL**

Scale: 3/8" = 1'-0"

**GENERAL NOTES:**

- All Regulatory Signs Shall Be High Intensity And In Accordance With The Indiana Manual On Uniform Traffic Control Devices, Most Recent Edition.
- All Pavement Markings Shall Be White Thermoplastic And Span Across Approach Lanes.
- Signs S3-1 & W14-2 To Be Installed When Required By The Town Of Plainfield.
- Where Pedestrian Cross Traffic Is Not Established, School Crossing Pavement Markings And Sign "C" May Be Omitted At The Discretion Of The Town Engineer.

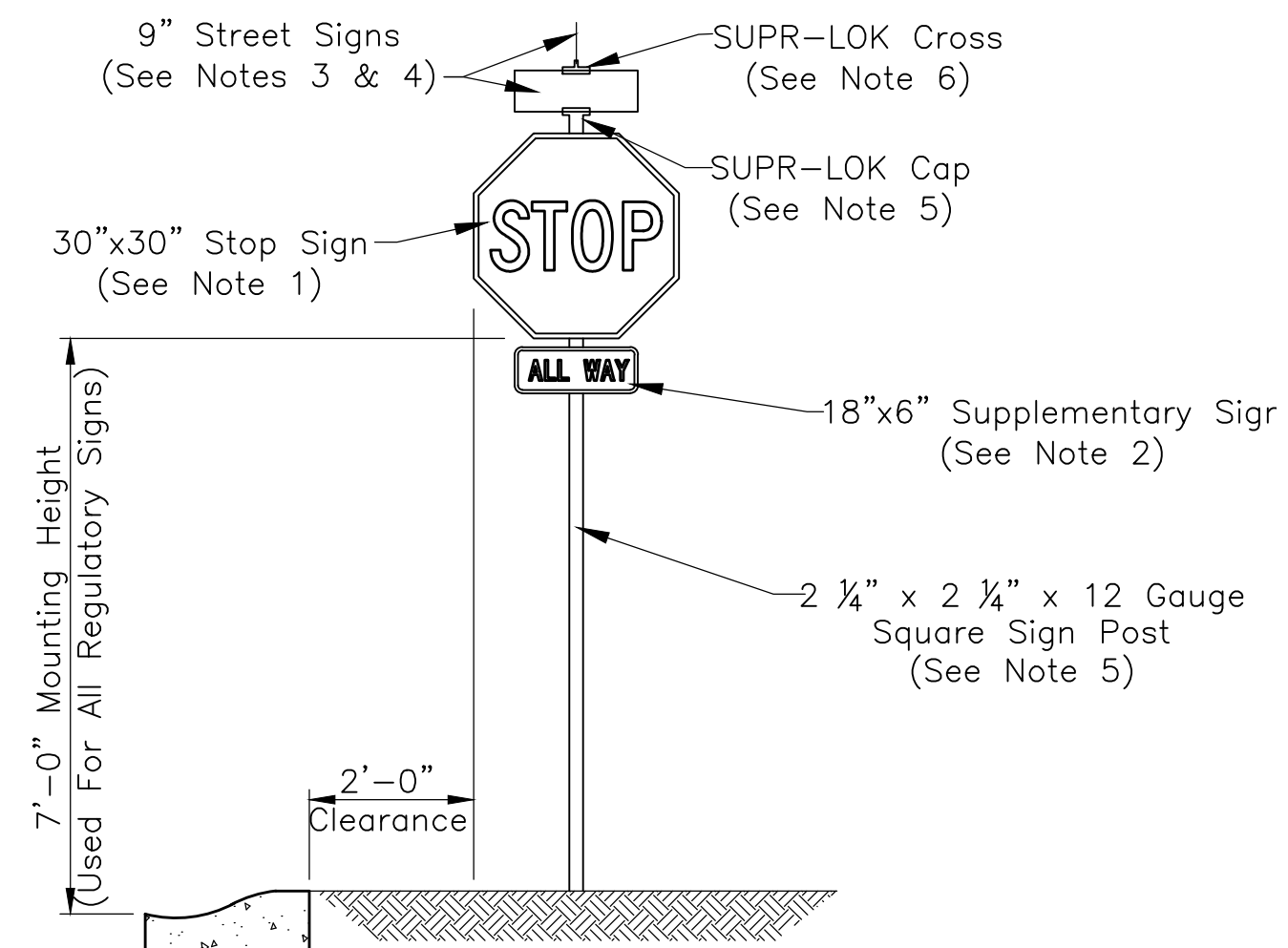

**TYPICAL REGULATORY/WARNING SIGN REQUIREMENTS**

Scale: None

- Stop Sign (R1-1) Shall Be High Intensity And In Accordance With Most Recent Indiana Manual On Uniform Traffic Control Devices. Unless Otherwise Detailed On This Sheet, Other Regulatory Signs Shall Be A Minimum Of 18"x24".
- A Multi-Way Stop Intersection Requires An "ALL WAY" (R1-3P) Supplementary Sign 18" Wide By 6" Tall In Accordance With Said Manual.
- Streets Shall Be So Signed At Non-Signalized Intersections With Two Such Street Sign Assemblies Typically Required. Separate 12' Square Sign Post For Street Signs Permitted Only At Signalized Intersections.
- Street Signs Shall Be 9" Tall Extruded Aluminum (6063-T6) Green Background With White Letters.
- Regulatory Signs, Other Than Stop Signs, Shall Be Mounted On 12' - 2 1/4" x 2 1/4" x 12 Gauge Square Sign Posts. SUPR-LOK Cap Shall Be Model #975QX. Regardless If Material For Posts Is Other Than As Shown Hereon, Mounting Height Shall Be 7'-0" From Roadway Edge Of Pavement
- SUPR-LOK Cross Shall Be Model #990X. For Non-Urban Intersections, Stop Sign To Be Placed A Minimum Of 6' From Cross-Street.
- For Urban Intersections See Handicap Ramp Detail On Sheet 4 Of The Town Standards.

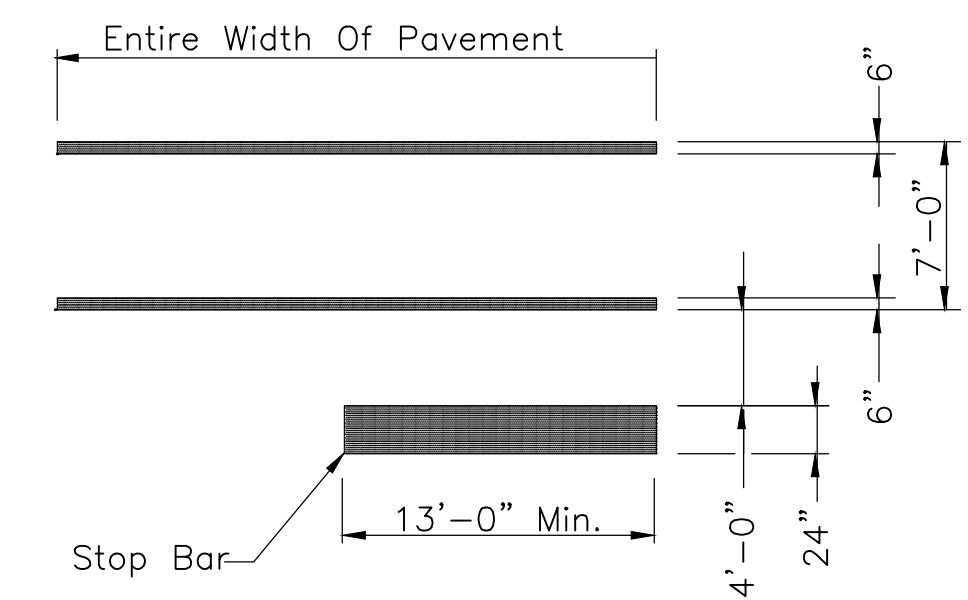

**INTERSECTION CROSSWALK DETAIL**

Scale: 1/8" = 1'-0"

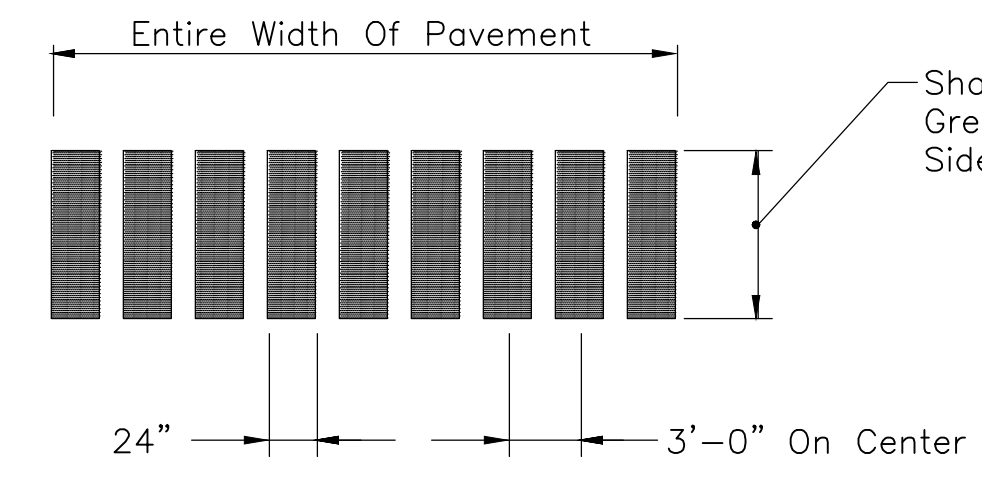

**SPECIAL CROSSWALK DETAIL**

Scale: 3/8" = 1'-0"

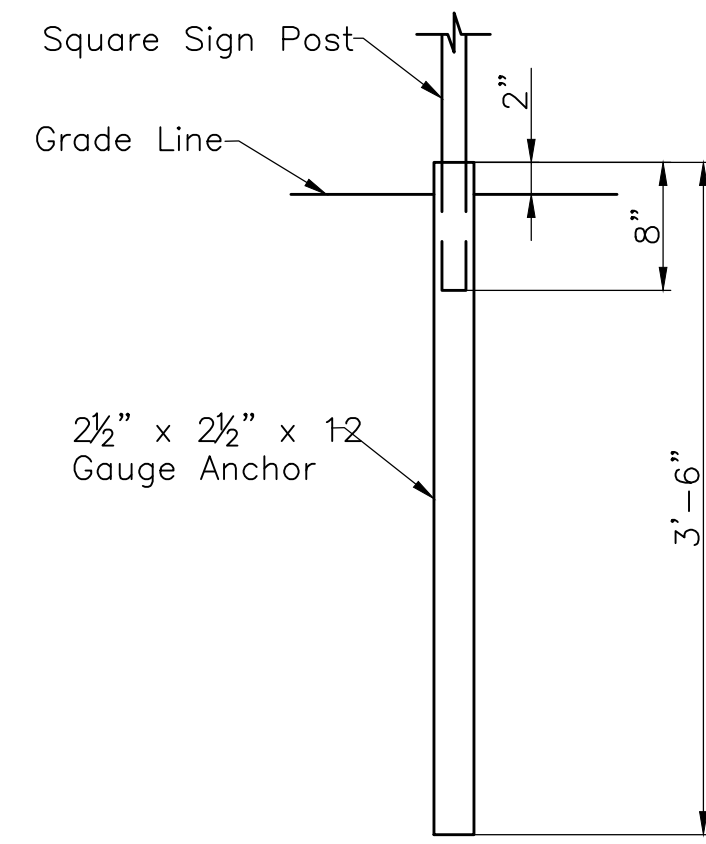

**UNREINFORCED ANCHOR BASE**

Scale: 1" = 1'-0"

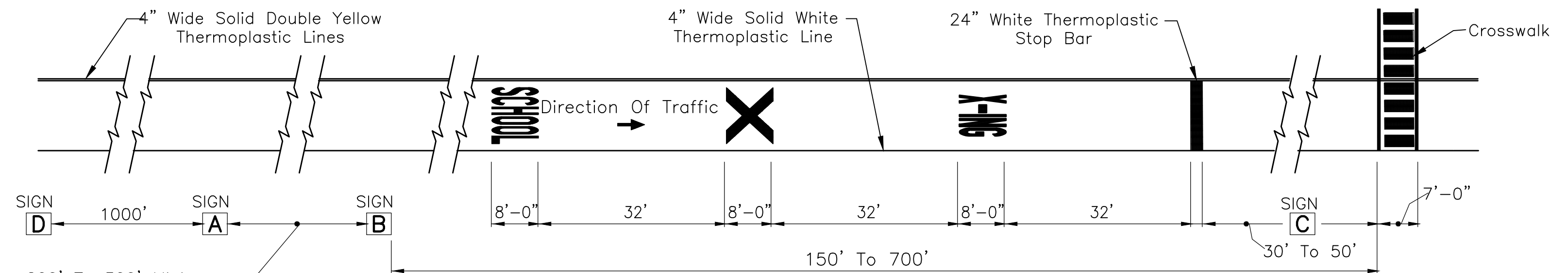

**SCHOOL ZONE APPROACH DETAIL**

Scale: 1/16" = 1'-0"

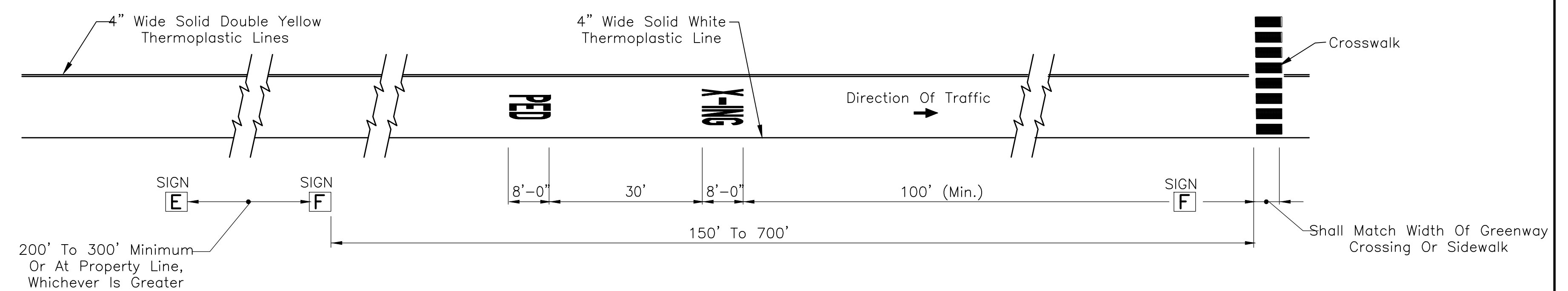

**PEDESTRIAN CROSSING APPROACH DETAIL - COLLECTOR OR ABOVE**

Scale: 1/16" = 1'-0"

REVISIONS		
Rev. No.	Description	Date

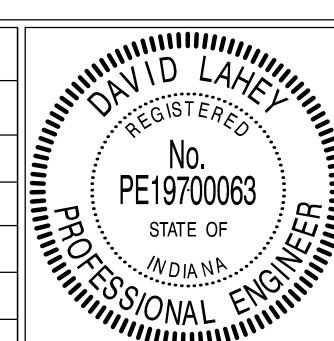

RECOMMENDED FOR APPROVAL	<i>David Lahey</i>	DESIGN ENGINEER	01/01/2019	DATE
APPROVED	<i>Samuel...</i>	TOWN ENGINEER	01/01/2019	DATE
APPROVED	<i>Jane...</i>	DIRECTOR OF TRANSPORTATION	01/01/2019	DATE

TOWN OF PLAINFIELD	
MISCELLANEOUS DETAILS AND NOTES	

SHEET	06
OF	25

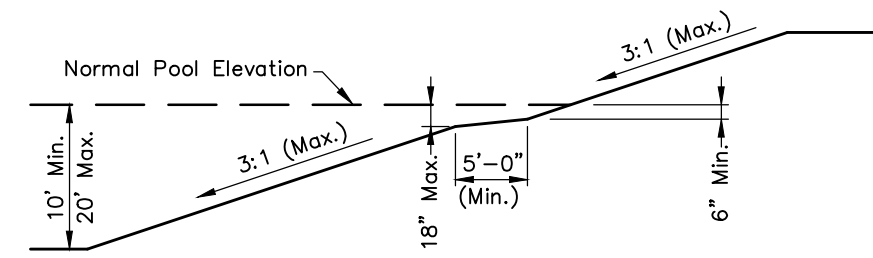

**TYPICAL DETENTION POND SECTION**  
Not To Scale

**NOTES:**

- 1.) Dry Bottom Basins Shall Be Subject To The Maximum Of 3:1 Slope Above The Basin Floor. The Longitudinal Slope Shall Be Subject To General Note 1 As Set Out On Sheet 09. The Transverse Grade Shall Be 2% Minimum.
- 2.) Emergency Overflow Facilities Such As A Weir Or Spillway Shall Be Provided For The Release Of Exceptional Storm Runoff Or In Emergency Conditions Should The Normal Discharge Devices Become Totally Or Partially Inoperative.
- 3.) Plainfield DPW May Approve Alternate Detention Pond/Basin Sections.

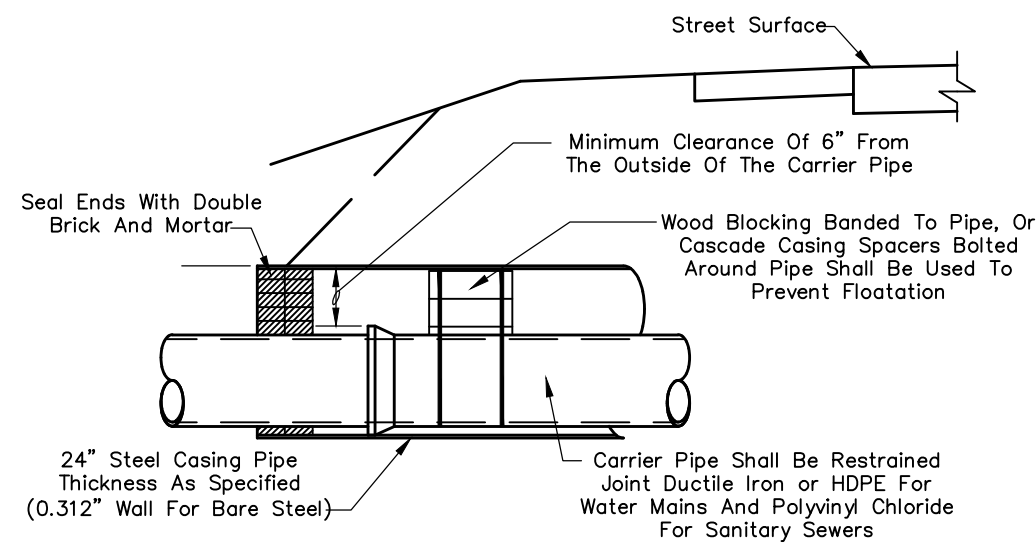

**TYPICAL STREET CASING DETAIL FOR UP TO 12" CARRIERS**  
Not To Scale

**NOTES:**

- 1.) Bored Or Jacked Crossings Require Intimate Knowledge Of Site Conditions; Therefore, Construction Is Subject To Certified Special Provisions Prepared By The Design Engineer.
- 2.) Casings Depicted Hereon Do Not Necessarily Comply With INDOT Permit Requirements, But Are Intended To Be Used For Crossings Of Public Roads Under The Jurisdiction Of The Town Of Plainfield When Open Cut Of Such Roads Is Not Permitted.
- 3.) Refer To Appropriate Plainfield Standards For Carrier Pipe Requirements.

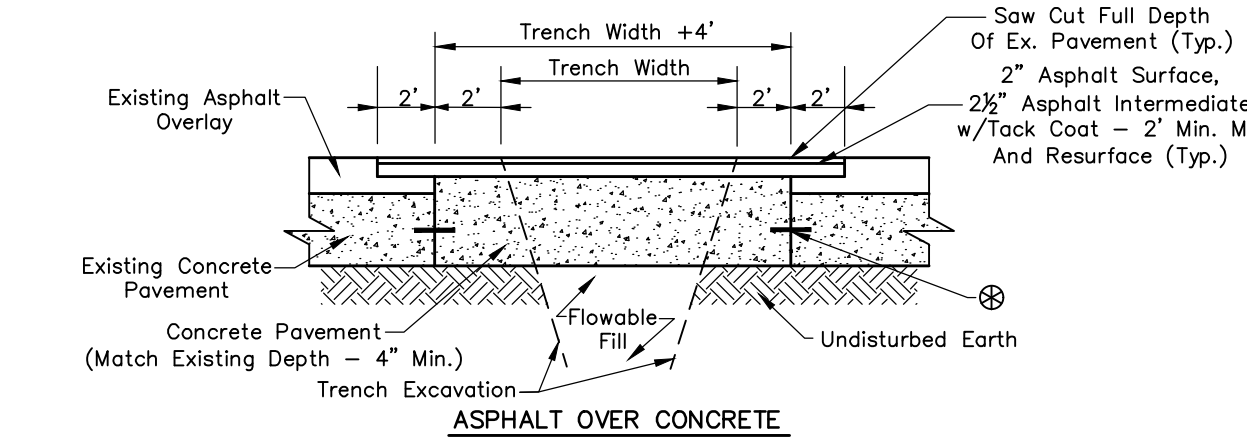
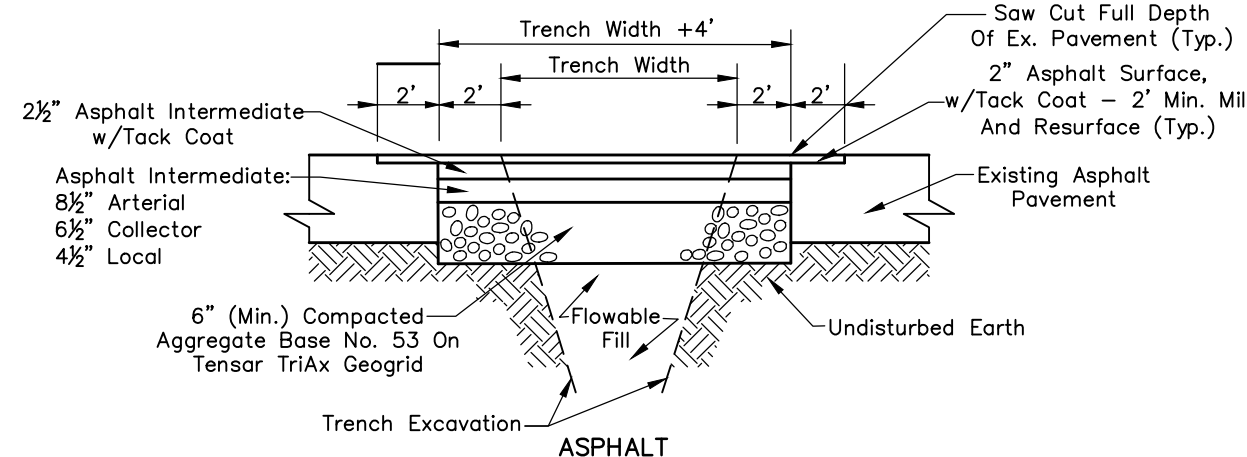
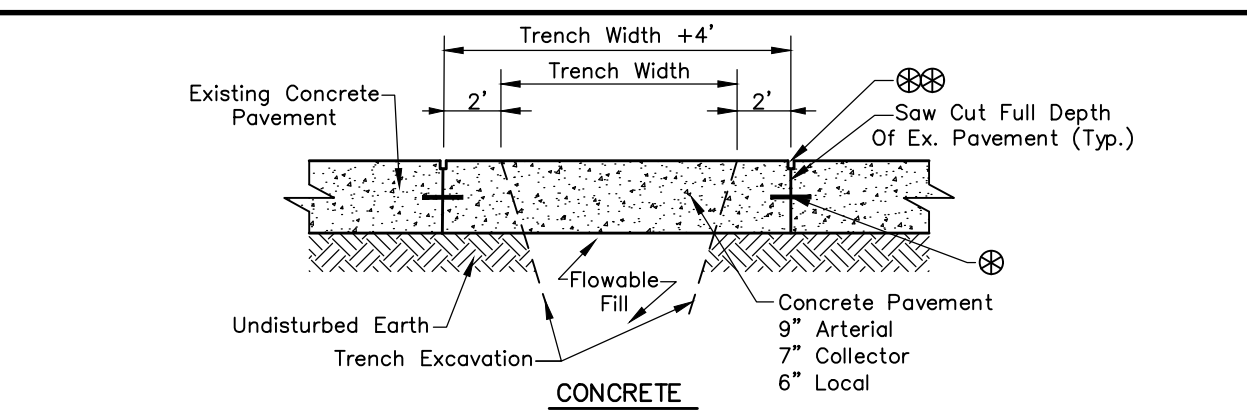

**PAVEMENT RECONSTRUCTION DETAILS**  
Not To Scale

**NOTES:**

- 1.) All Concrete Shall Be Air Entrained, 6 Bag Per Cubic Yard With 4,000 PSI Minimum 28 Day Strength. Concrete Surface Shall Be Broom Finished Perpendicular To Traffic Flow.
- 2.) Refer To INDOT Standard Drawing E506-CCPP-01 For Dowel Bar Spacing and Diameter And E503-COPR-03 For Retrofit Bar Spacing and Diameter.
- 3.) Refer To INDOT Standard Drawing E503-CCPJ-03 For Joint Seal Details. Joint Seals Are Not Required If Concrete Pavement Is Overlaid.

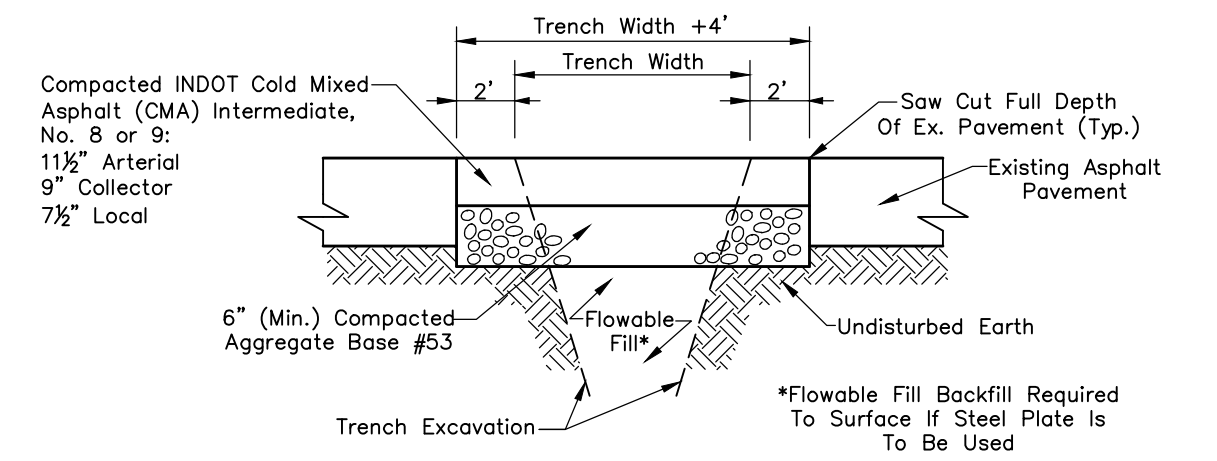

**TEMPORARY ASPHALT PATCH**  
Not To Scale

**NOTES:**

- 1.) Steel Plate Required Over Trench To Open Roadway To Traffic. Pavement Reconstruction Or Temporary Asphalt Patch To Be Placed Within 48 Hours.
- 2.) Cold Mixed Asphalt (CMA) Shall Not Be Used When The Ambient Temperature Is Less Than 40F. Use Flowable Fill To Surface.

**DEVELOPMENT STANDARD - DETAIL DS-G01**

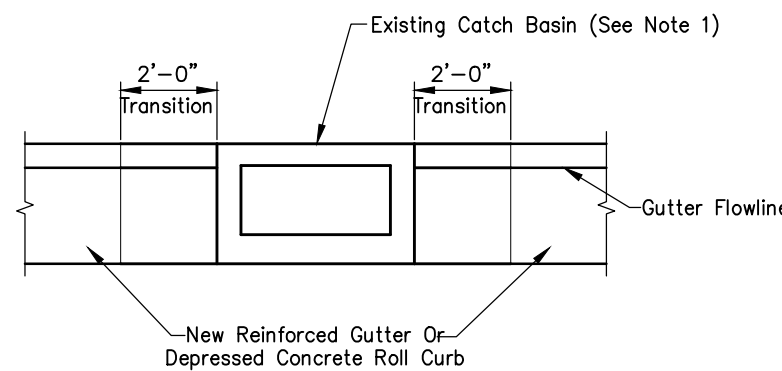

**EXISTING CATCH BASIN MODIFICATION**  
Scale: 3/4"=1'-0"

**NOTES:**

- 1.) Existing Catch Basin Within Limits Of New Approach That Can Not Be Relocated Due To Existing Gutter Flow, As Approved By Plainfield DPW.
- 2.) Provide Flat Cap And Cut Structure Height As Required To Accept Neenah R-3287-5, EJ 5425 Or US Foundry 4628-6132 B.U.D.
- 3.) Contractor To Verify Existing Casing Size To Determine Replacement.

**DEVELOPMENT STANDARD - DETAIL DS-G05**

**DEVELOPMENT STANDARD - DETAIL DS-G02**

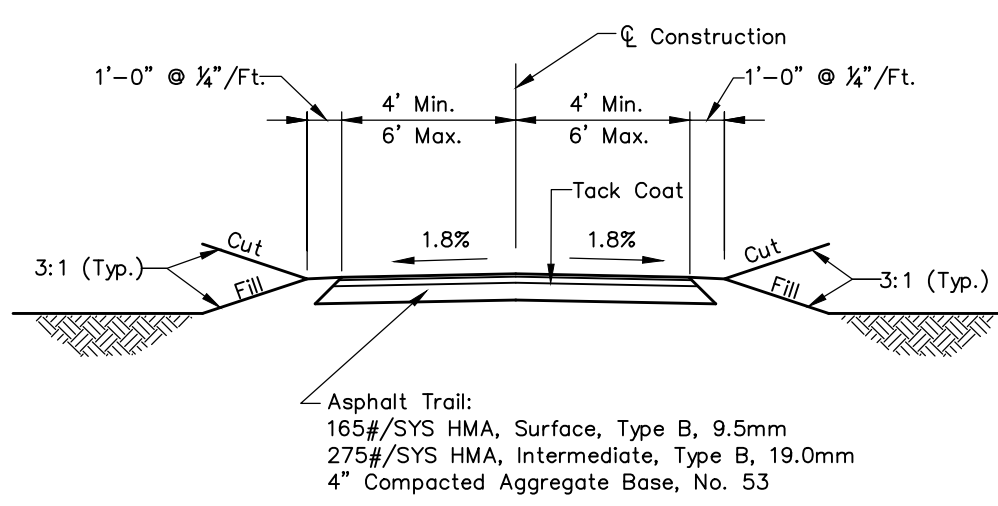

**TYPICAL TRAIL CROSS SECTION**  
Not To Scale

**NOTES:**

- 1.) Cross Slope Shall Be 1.8% Maximum For Crowns, Transitions, And Superelevations.

**DEVELOPMENT STANDARD - DETAIL DS-G06**

**DEVELOPMENT STANDARD - DETAIL DS-G03**

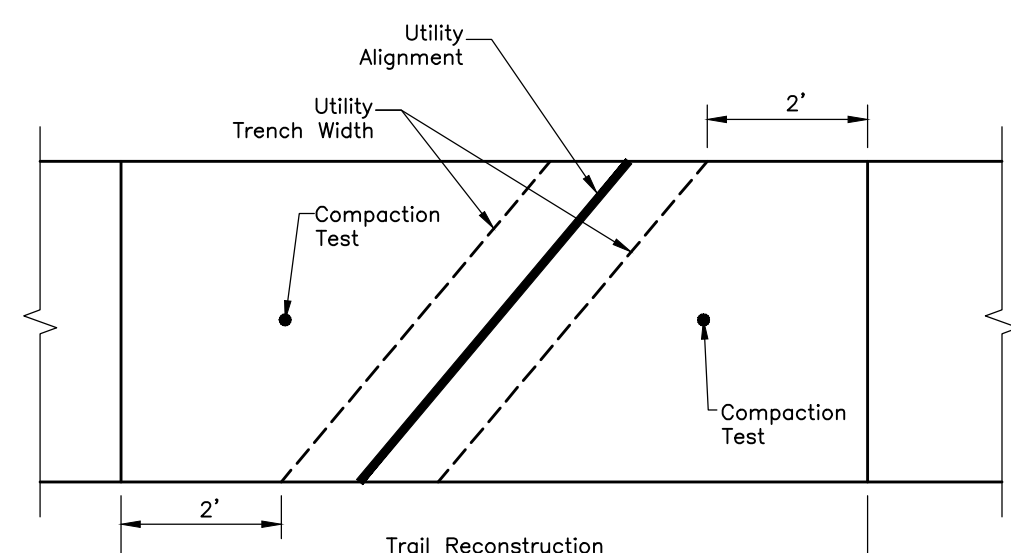

**EXISTING TRAIL RECONSTRUCTION**  
Not To Scale

**NOTES:**

- 1.) Full Depth Saw-Cut 2 Feet On Either Side Of The Outer Limits Of The Utility Trench And Remove Pavement. Saw-Cut Should Be Made Perpendicular To The Trail's Centerline.
- 2.) Backfill Utility Trench With Flowable Fill Per Pavement Reconstruction Detail DS-G03.
- 3.) Aggregate Subbase Compaction Adjacent To The Utility Trench Shall Not Be Less Than 95% Of The Maximum Dry Density As Determined By AASHTO T99. One Compaction Test On Each Side Of The Utility Trench Shall Be Performed.
- 4.) Replace Asphalt Per Typical Trail Cross Section Detail DS-G06 Making Sure To Match Existing Grades.

**DEVELOPMENT STANDARD - DETAIL DS-G07**

**DEVELOPMENT STANDARD - DETAIL DS-G04**

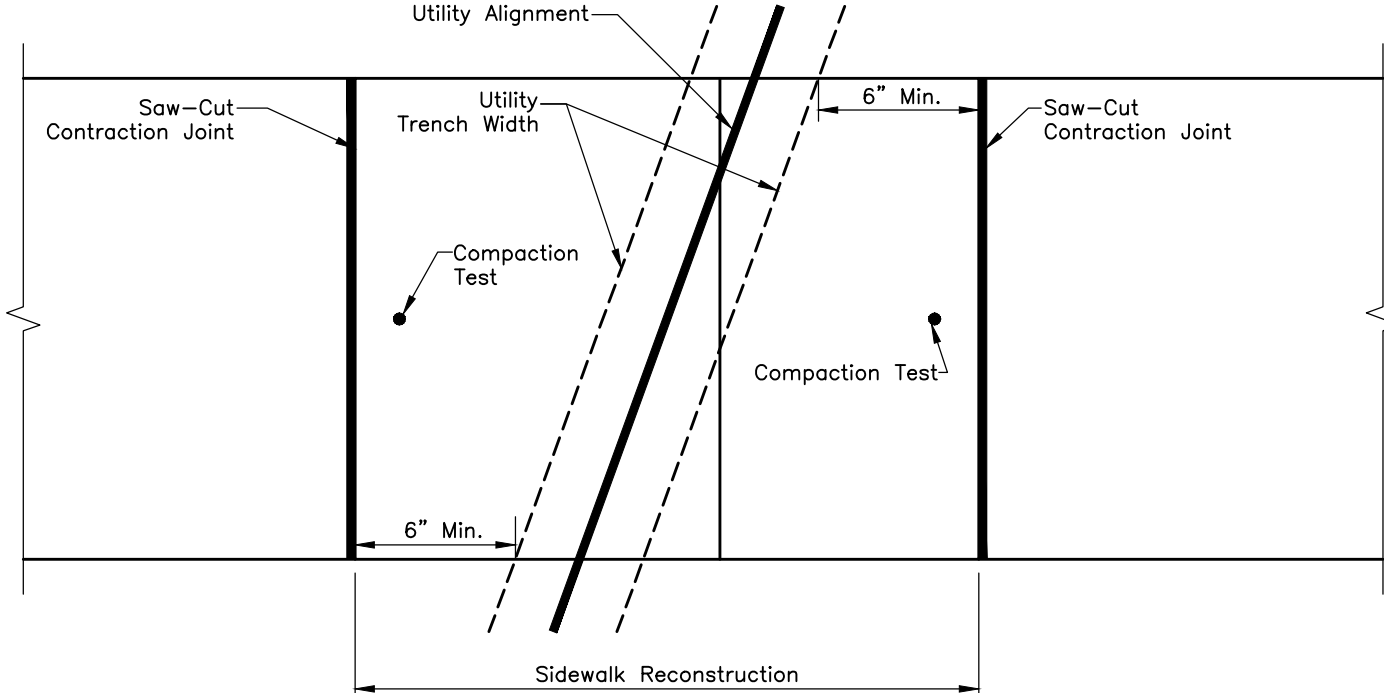

**EXISTING SIDEWALK RECONSTRUCTION**  
Not To Scale

**NOTES:**

- 1.) Full Depth Saw-Cut Nearest Contraction Joints Outside Of Utility Trench And Remove Existing Sidewalk.
- 2.) Backfill Utility Trench With Flowable Fill Per Pavement Reconstruction Detail DS-G03.
- 3.) Aggregate Subbase Compaction Adjacent To The Utility Trench Shall Not Be Less Than 95% Of The Maximum Dry Density As Determined By AASHTO T99. One Compaction Test On Each Side Of The Utility Trench Shall Be Performed.
- 4.) Replace Preformed Joint Filler If Removed During Sidewalk Removal.
- 5.) If Utility Alignment Follows The Sidewalk Joint Take Adjacent Sidewalk Panels Out.
- 6.) If Utility Trench Encroaches Within 6" Inches Of Contraction Joint Take Adjacent Sidewalk Panel Out.
- 7.) Replace Sidewalk Per Typical Sidewalk Detail On Sheet 03 Making Sure To Match Existing Grades.

**DEVELOPMENT STANDARD - DETAIL DS-G08**

REVISIONS		
Rev. No.	Description	Date



RECOMMENDED FOR APPROVAL: *David Lahey*, DESIGN ENGINEER, DATE: 01/01/2019  
 APPROVED: *[Signature]*, TOWN ENGINEER, DATE: 01/01/2019  
 APPROVED: *[Signature]*, DIRECTOR OF TRANSPORTATION, DATE: 01/01/2019

TOWN OF PLAINFIELD  
 GENERAL (G)  
 DEVELOPMENT STANDARDS  
 SHEET 07 OF 25

**STORM SEWER REINFORCED CONCRETE PIPE**

- 1.) Reinforced Concrete Pipe Shall Be Class III, IV, or V As Specified In ASTM C76.
- 2.) Reinforced Elliptical Concrete Pipe Shall Be Class HE-II Or HE-IV As Specified In ASTM C507.
- 3.) Lift Holes Are Not Allowed For Pipe Less Than 24 Inches In Diameter. A Maximum Of Two Lift Holes Are Allowed For Pipe 24 Inches In Diameter Or Larger. Lift Holes Shall Be Repaired According To Most Recent INDOT Standard Specifications.
- 4.) Fittings And Specialties Shall Be In Accordance With The Specifications For The Type Of Pipe Being Used.
- 5.) Each Pipe Section Shall Be Marked With Date Of Manufacture, Size And Class Of Pipe, Specification Designation, Manufacturer And Plant Identification.
- 6.) Pipe Shall Be Furnished With A Bell Or Groove On One End Of A Unit Of Pipe And A Spigot Or Tongue On The Adjacent End Of The Adjoining Pipe. All Joints Shall Have A Groove On The Spigot For Placement Of A Rubber "O"-Ring Or Profile Gasket In Accordance With ASTM C443. The Gasket Shall Be A Continuous Ring Which Fits Snugly Into The Annular Space Between The Overlapping Surfaces Of The Assembled Pipe Joint.

**STORM SEWER POLYVINYL CHLORIDE (PVC) PIPE**

- 1.) Pipe Diameters Of 12 Inches Through 15 Inches Shall Meet Or Exceed All The Requirements Of ASTM D3034, And Shall Have A Minimum Cell Classification Of 12454. Reference Should Be Made To ASTM D1784 For A Summarization Of Cell Class Properties. Pipe Diameters Greater Than 15 Inches Shall Meet Or Exceed All Requirements Of ASTM F679, And Shall Have A Minimum Cell Classification Of 12454. PVC Ribbed Sewer Pipe Shall Meet Or Exceed All Requirements Of ASTM F794, And Shall Have A Minimum Cell Classification Of 12454.
- 2.) The Minimum Wall Thickness Of Pipe 10 Inches Through 15 Inches In Diameter Shall Conform To SDR-26, Type PSM, As Specified In ASTM D3034. The Minimum Wall Thickness For Pipe Diameters Greater Than 15 Inches Shall Conform To PS 46 As Specified In ASTM F679. PVC Pipe Shall Have A Minimum Pipe Stiffness Of 46 Pounds Per Square Inch For Each Diameter When Measured At Five Percent Deflection And Tested In Accordance With ASTM D2412.
- 3.) Pipe Joints Shall Have A Bell Wall, Gasket Groove, And Spigot Which Are Integral With The Pipe. The Assembly Of Joints Shall Be In Accordance With The Pipe Manufacturer's Recommendations And ASTM D3212. No Solvent Cement Joints Shall Be Allowed. Gasket Material Shall Be Constructed Of Styrene Butadiene Or Butyl Rubber And Meet The Requirements Of ASTM F477.
- 4.) Each Pipe Section Shall Be Marked With Name Of Manufacturer, Trademark Or Tradename, Nominal Pipe Size, Production/Extrusion Code, Material And Cell Classification, And ASTM Number.
- 5.) Installation Shall Be In Accordance With Recommended Practice ASTM D2321.

**STORM SEWER HIGH DENSITY POLYETHYLENE (HDPE) CORRUGATED PIPE**

- 1.) Requirements For Test Methods, Dimensions, And Markings Are Those Found In AASHTO Specifications M-252 And M-294.
- 2.) Pipe And Fittings Shall Be Made Of Polyethylene Compounds Which Meet Or Exceed The Requirements Of Type III, Category 4 Or 5, Grade P33 Or P34, Class C Per ASTM D1248.
- 3.) Minimum Pipe Stiffness Values Shall Be In Accordance With AASHTO Specifications M-294.
- 4.) The HDPE Corrugated Pipe Shall Have An Integrally Formed Smooth Interior. Male And Female Pipe Ends Which Allow The Construction Of Overlapping Gasket Joints Shall Be Made In Conformance With ASTM D3212. Neoprene Gaskets Shall Meet ASTM F477.
- 5.) Installation Shall Be In Accordance With Recommended Practice ASTM D2321.
- 6.) HDPE Pipe Greater Than 36 Inches In Diameter Shall Not Be Allowed For Use In The Town Of Plainfield.
- 7.) HDPE Pipe 12 Inches Through 18 Inches In Diameter May Be Used Within The Public Right-Of-Way Subject To The Bedding Requirements For Flexible Pipe. HDPE Pipe Greater Than 18 Inches In Diameter Shall Not Be Allowed For Use Within The Public Right-Of-Way In The Town Of Plainfield.

**STORM SEWER CORRUGATED POLYPROPYLENE (PP) PIPE**

- 1.) 12-inch through 60-inch Pipe Shall Be Smooth Interior And Annular Exterior Corrugated Polypropylene (PP) Pipe Meeting The Requirements Of ASTM F2764, ASTM F2881 or AASHTO M330 Type S (Double-Wall) Or D (Triple-Wall), For Respective Diameters.
- 2.) Material For Pipe And Fitting Production Shall Be An Impact Modified Copolymer Meeting The Material Requirements Of ASTM F2764, ASTM F2881 And AASHTO M330, For Respective Pipe Diameters.
- 3.) Watertight Joints Shall Be Bell-And-Spigot Meeting The Watertight Requirements Of ASTM D3212. Gaskets Shall Comply With The Requirements Of ASTM F477. Gaskets Shall Be Installed By The Pipe Manufacturer And Covered With A Removable Wrap To Ensure The Gasket Is Free From Debris. A Joint Lubricant Supplied By The Manufacturer Shall Be Used On The Gasket And Bell During Assembly.
- 4.) Fittings Shall Conform To ASTM F2764, ASTM F2881 Or AASHTO M330, With The Exception Of Meeting The Watertight Joint Performance Requirements Of ASTM D3212. Gasketed Bell And Spigot Connections Shall Utilize A Spun-on, Welded Or Integral Bell And Spigot With Gaskets Meeting ASTM F477.

**STORM SEWER GENERAL NOTES**

- 1.) Storm Sewer Pipe Of Other Material Or Material Not Meeting These Specifications Shall Require The Prior Written Approval Of Plainfield DPW.
- 2.) The Contractor Shall Submit Information To The Town Engineer Showing Conformance With These Specifications Upon Request.
- 3.) As-Built Drawings Shall Be Submitted To Plainfield DPW.
- 4.) To Get Relief From The Town's Inlet And Manhole Requirements, A Structural Best Management Practice Or Isolation From The Town's System Is Required. The Town Standards For Bedding Of Pipe And Pipe Material For Storm Sewers Are Required Regardless.
- 5.) The Centerline Of Storm Water Quality Structures Shall Be Located As Required So As To Be Within 15' From Edge Of Pavement. Structure Cone Sections Shall Be Rotated Towards The Street.

**STORM SEWER DEFLECTION TESTING AND TELEVISION**

- 1.) Deflection Testing Is Required For All Mainline Flexible Pipe And Plainfield DPW Shall Be Given 24 Hour Written Notice Of Deflection Testing. An Allowable Deflection Of 5 Percent Inside Pipe Diameter Will Be Acceptable After All Backfilling Has Been In Place For 30 Days. A Nine-Point "Go-No-Go" Mandrel Shall Be Used For The Deflection Test. A Proving Ring Shall Be Provided For Each Mandrel. All Pipe Exceeding The Allowable Deflection Shall Be Televised To Determine The Extent Of Replacement Or Rerouting Required. The Reworked Section Shall Be Retested 30 Days After Completion. Contractor Shall Bear All Testing Costs. The "Go-No-Go" Mandrel Shall Be Manually Pulled Without The Use Of Mechanical Devices.
- 2.) Televising Is Required For All Pipe Installations. Plainfield DPW Shall Be Given 24 Hour Written Notice Of Televising. A Camera Equipped With Remote Control Devices To Adjust Light Intensity And 1,000 Linear Feet Of Sewer Cable Shall Be Provided. The Camera Shall Transmit A Continuous Image To The Television Monitor As It Is Being Pulled Through Pipe. The Image Shall Be Clear Enough To Enable The Town Of Plainfield Representative And Others Viewing The Monitor To Easily Evaluate The Interior Condition Of The Pipe. The Camera Shall Stamp The Video Tape With Linear Footage And Project Number, And An Audio Voice-Over Shall Be Made During The Inspection Identifying Problems. Contractor Shall Bear All Televising Costs.
- 3.) The Pipe Shall Be Thoroughly Cleaned Before Installing Camera And Commencing Televising.
- 4.) If Any Pipe And/Or Joint Is Found To Be Leaking In Such A Way As Soil Migration Is Likely In The Sole Judgment Of The Town, The Contractor Shall Repair That Portion Of The Work To The Satisfaction And Approval Of The Town Of Plainfield.

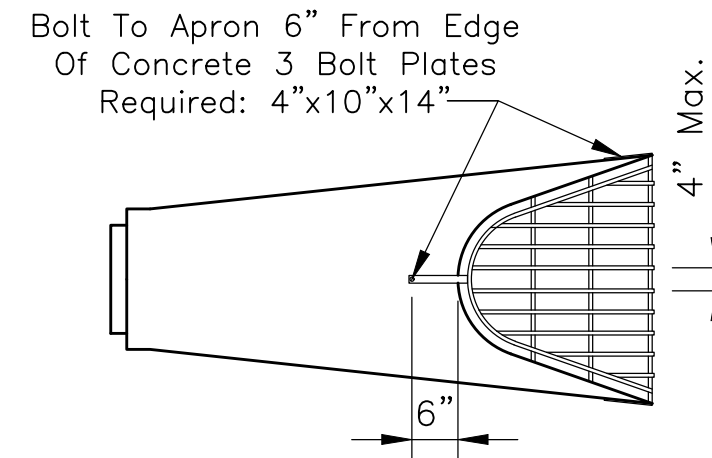

APRON SIZE	V-BAR SIZE (Ø)	H-BAR SIZE (Ø)	NO. OF H-BARS	BOLT DIA.	"A" DIM
12	1/2	3/4	3	1/2	4
15	1/2	3/4	3	1/2	4 1/2
18	1/2	3/4	4	1/2	4 1/2
21	1/2	3/4	4	1/2	5
24	3/4	3/4	4	1/2	5
27	3/4	3/4	4	1/2	5 1/2
30	3/4	3/4	4	1/2	5 1/2
36	3/4	1	4	3/4	8
42	3/4	1	4	3/4	8
48	3/4	1	5	3/4	8
54	3/4	1 1/2	5	3/4	8
60	3/4	1 1/2	5	3/4	8
66	3/4	1 1/2	5	3/4	8
72	3/4	1 1/2	5	3/4	9
84	3/4	1 1/2	5	3/4	10
90	3/4	1 1/2	5	3/4	10

**NOTES:**

1. Animal Guard Is Not Required For Culvert Crossings

**ANIMAL GUARD**

Scale: None

End Section End Treatment (Per Animal Guard Detail) Involving Horizontal Minimum No. 12 Gauge Hot Dipped Galvanized Steel Tubes Of Suitable Diameter And Suitably Affixed To Sloping Portion Of The End Section Shall Be Provided

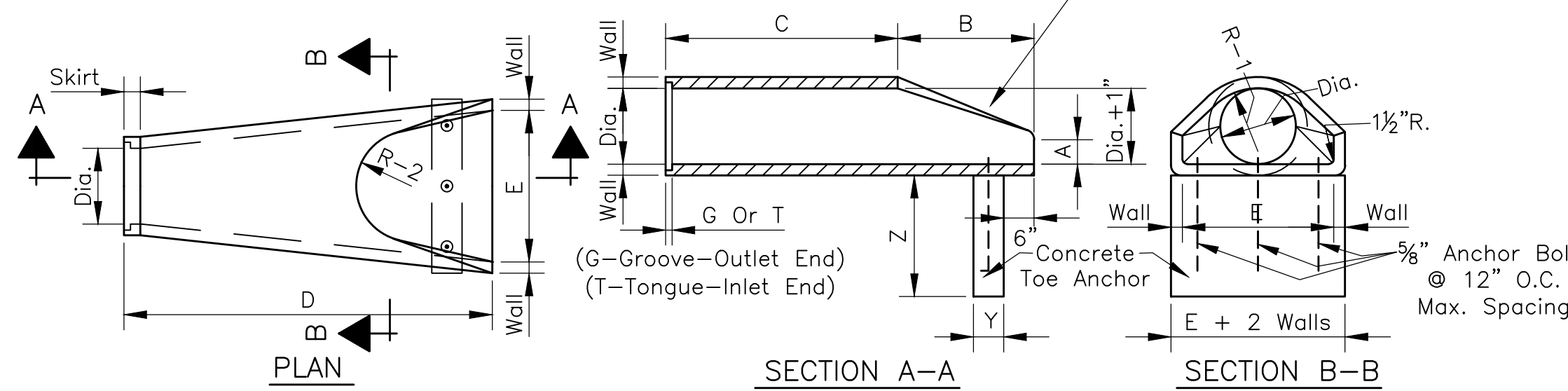

DIA.	WALL	G or T	WT. SEC.	A	B	C	D	E	DIA.+1"	R-1	R-2	SKIRT	Y	Z
12	2	1 1/2	530	4	24	48 7/8	72 7/8	24	13	10 1/16	9	3 1/2	12	24
15	2 1/4	2	740	6	27	46	73	30	16	12 1/2	11	3 1/2	12	24
18	2 1/2	2 1/2	990	9	27	46	73	36	19	15 1/2	12	4	12	24
21	2 3/4	2 1/2	1280	9	35	38	73	42	22	16 1/8	13	4	12	36
24	3	2 1/2	1520	9 1/2	43 1/2	30	73 1/2	48	25	16 11/16	14	4 1/2	18	36
27	3 1/4	2 1/2	1930	10 1/2	48	25 1/2	73 1/2	54	28	17 3/4	14 1/2	4 1/2	12	36
30	3 1/2	3	2190	12	54	19 3/4	73 3/4	60	31	18 5/16	15	5	12	36
33	3 3/4	3 3/8	3150	13 1/2	58 1/2	39 1/4	97 3/4	66	34	23 3/4	17 1/2	5 1/2	18	36
36	4	3 1/2	4100	15	63	34 3/4	97 3/4	72	37	24 1/16	20	5 1/2	18	36
42	4 1/2	3 3/4	5380	21	63	35	98	78	43	27 1/4	22	5 1/2	24	36
48	5	4 1/4	6550	24	72	26	98	84	49	28 1/8	22	5 3/4	24	36
54	5 1/2	4 3/4	8040	27	65	35	100	90	55	32 7/8	24	6 1/4	30	36
60	6	5	8750	30	60	39	99	96	61	36 3/4	24	6 3/4	30	36
66	6 1/2	5 1/2	10630	24	78	21	99	102	67	35 11/16	24	7 1/4	30	36
72	7	6	12520	34	78	21	99	108	73	38 5/8	24	7 3/4	36	36
78	7 1/2	6 1/2	14430	24	78	21	99	114	79	41 15/16	24	8 1/2	36	36
84	8	7	16350	24	78	21	99	120	85	44 13/16	24	9	39	36

**PRECAST CONCRETE PIPE END SECTION**

Scale: None

REVISIONS		
Rev. No.	Description	Date

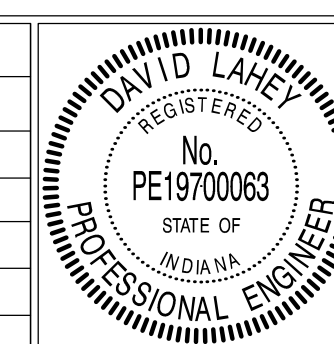

RECOMMENDED FOR APPROVAL: *David Lahey* DESIGN ENGINEER, DATE: 01/01/2019  
 APPROVED: *James Smith* TOWN ENGINEER, DATE: 01/01/2019  
 APPROVED: *James Smith* SUPERINTENDENT OF PUBLIC WORKS, DATE: 11/1/2019

**FLEXIBLE (PVC, PP OR HDPE) PIPE BEDDING DETAIL**

Scale: None

**NOTES:**

1. Special Consideration Should Be Made For Shallow Depth Flexible Pipe Where Flotation Is A Possibility.
2. Anti-Flotation Measures Should Be Considered Per Manufacturers Recommendation.

**NOTES:**

1. Precast Flared Reinforced Concrete Pipe End Sections Shall Be Used At Exposed Pipe Ends. Concrete Toe Anchors Shall Be Required. Plastic Pipe Shall Require A Full Length Section Of Reinforced Concrete Pipe Jointed By A Concrete Collar Prior To The Precast Concrete Pipe End Section.
2. Revetment Riprap In Accordance With The Most Recent INDOT Channel Design Guide Set On Geotextile In Accordance With The Most Recent INDOT Standard Specifications Shall Be Required At Inlet And Outlet Precast Flared Reinforced Concrete Pipe End Sections.
3. Pipe End Sections Shall Have Appropriately Designed Riprap Outlet Protection. Refer To Outlet Protection Detail On Sheet 18.

Finished Ground; However, Contractor Shall Coordinate Grade To Ensure Proper Pavement Section Or To Allow Placement Of Approved Loam Material To A Depth Of 8" For Seeding Or Sodding.

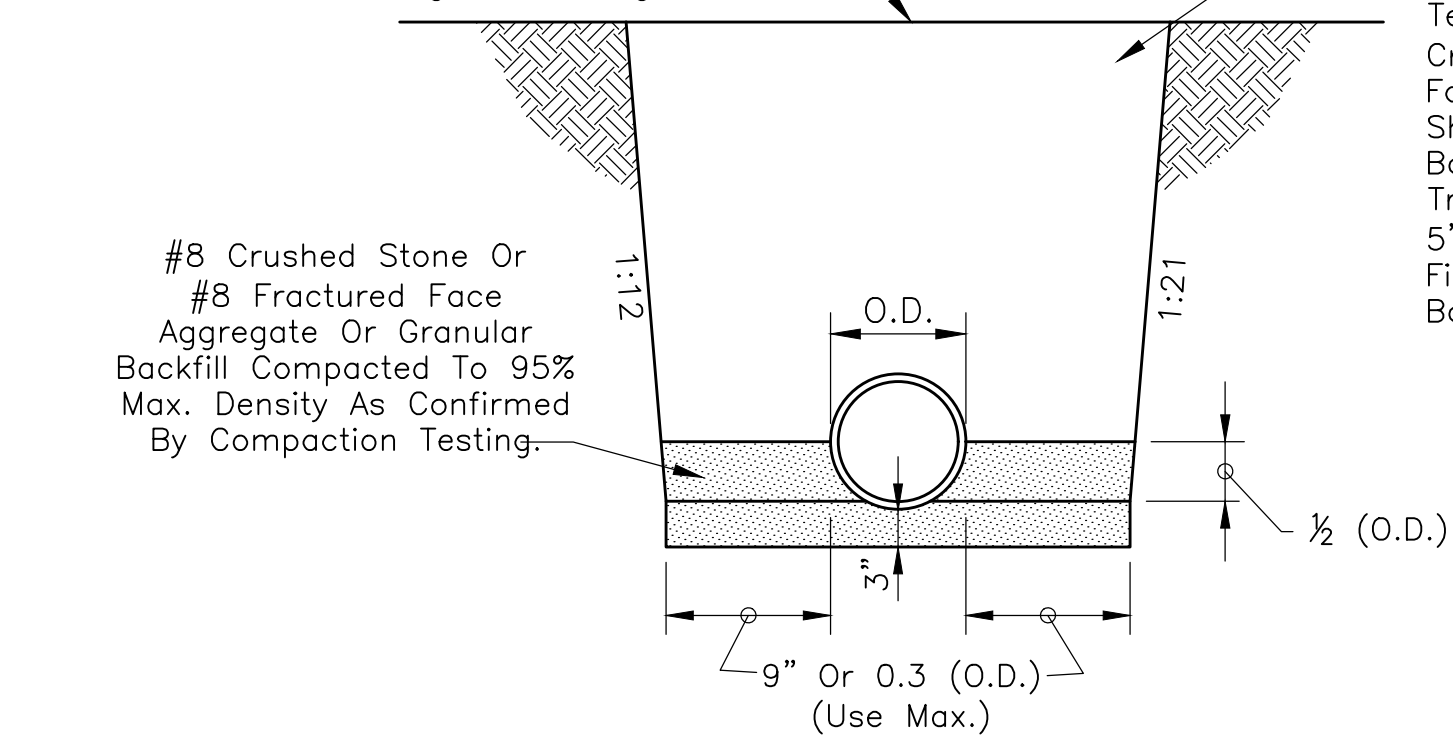

**RCP PIPE BEDDING DETAIL**

Scale: None

Structure Backfill According To INDOT Specification 211 When Trench Opening Encroaches Within 5' Of An Existing Or Proposed Street Or Sidewalk. Approved Backfill Material Outside Of B-Borrow Backfill Limits. Approved Backfill Material May Be Used Under Proposed Sidewalks Provided Sidewalks Are Constructed 6 Months After Backfilling Of Trenches Up To 6' Deep, 8 Months For Trenches 6'-10' Deep, 10-12 Months For Trenches Greater Than 10' Deep.

#8 Crushed Stone Or #8 Fractured Face Aggregate Hand Tamped Or Walked In To (1/2 O.D.)+12" Above Top Of Pipe

4" Min. (Below The Barrel) See Table Attached To Detail

#8 Crushed Stone Or #8 Fractured Face Aggregate Hand Tamped Or Walked In To 1/2 O.D.

#8 Crushed Stone Or #8 Fractured Face Aggregate, Bell Hole Excavated

Pipe Size	12" TO 15"	18" And Over
Bedding Below The Pipe Barrel	O.D./4 Min.=4"	O.D./4 Min.=8"

**TOWN OF PLAINFIELD**

**STORM SEWER BEDDING DETAILS AND NOTES**

**SHEET**

08  
OF  
25

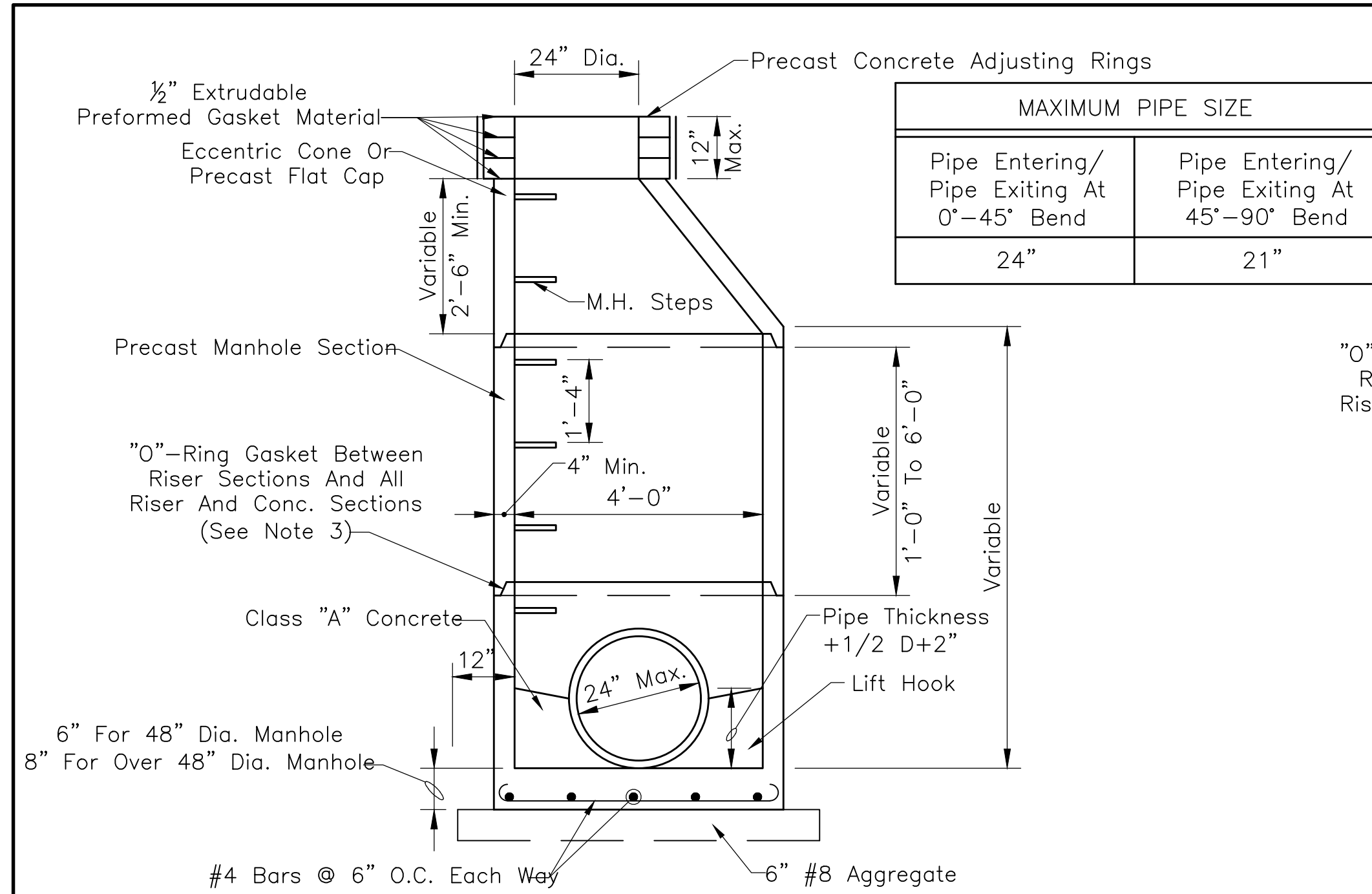

**MANHOLE TYPE C**  
Scale: 1/2"=1'-0"

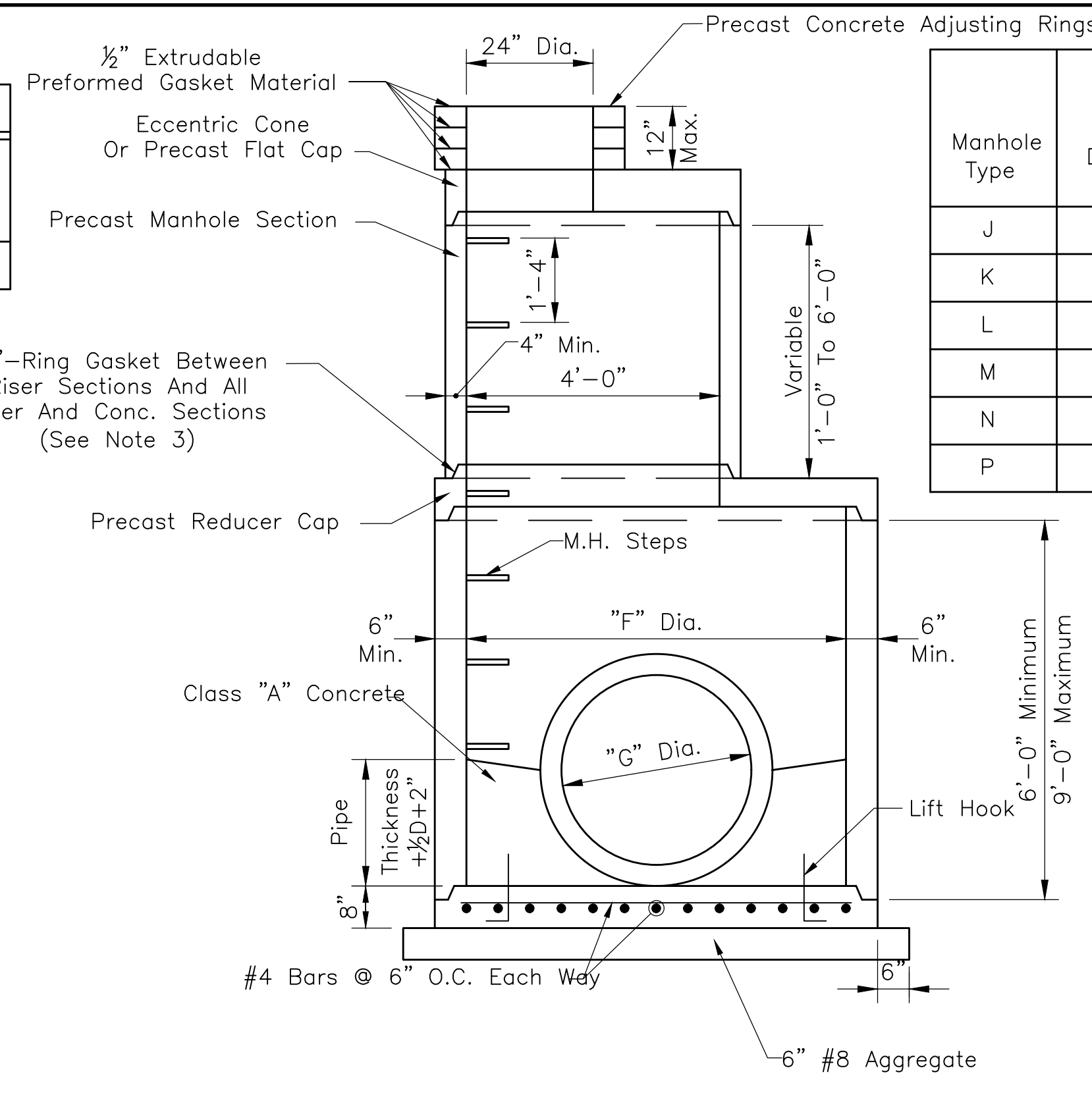

**MANHOLES-TYPE J, K, L, M, N & P**  
Scale: 1/2"=1'-0"

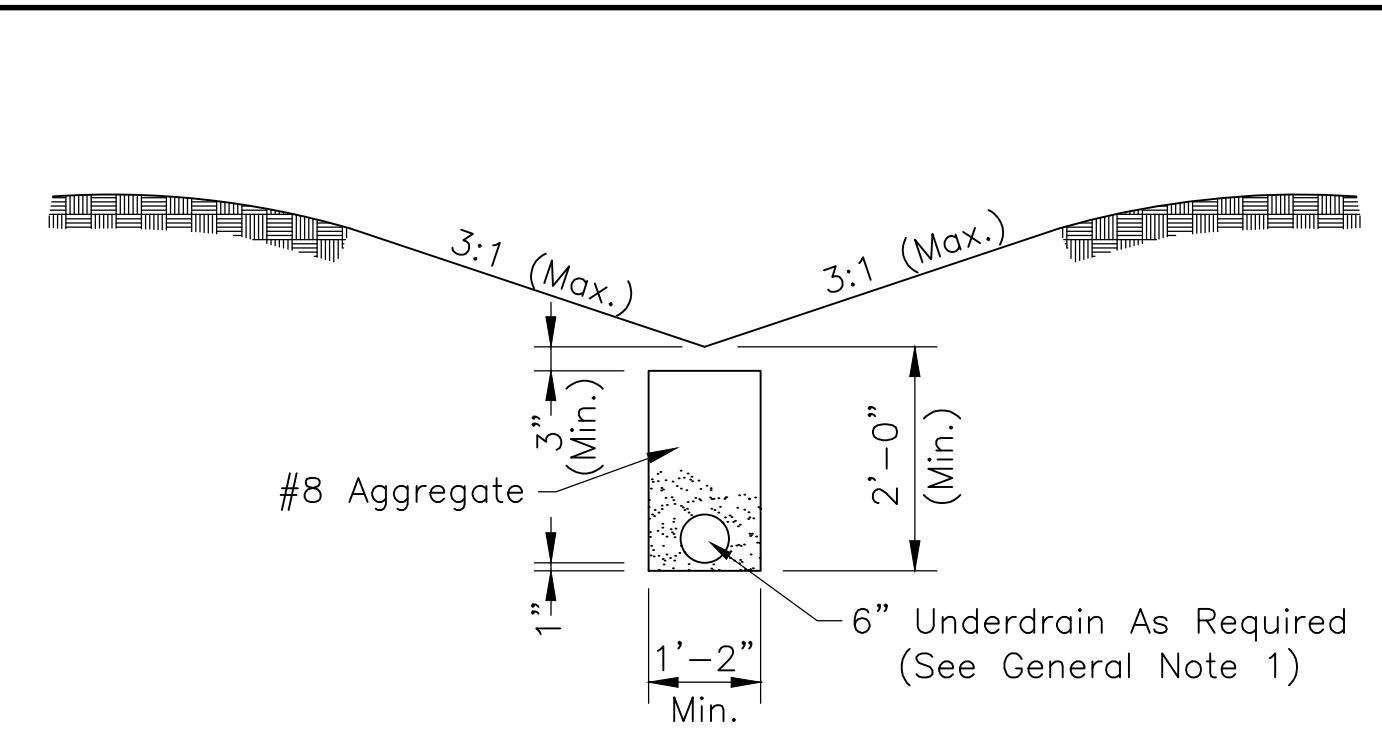

**SWALE UNDERDRAIN DETAIL**  
Scale: 1/2"=1'-0"

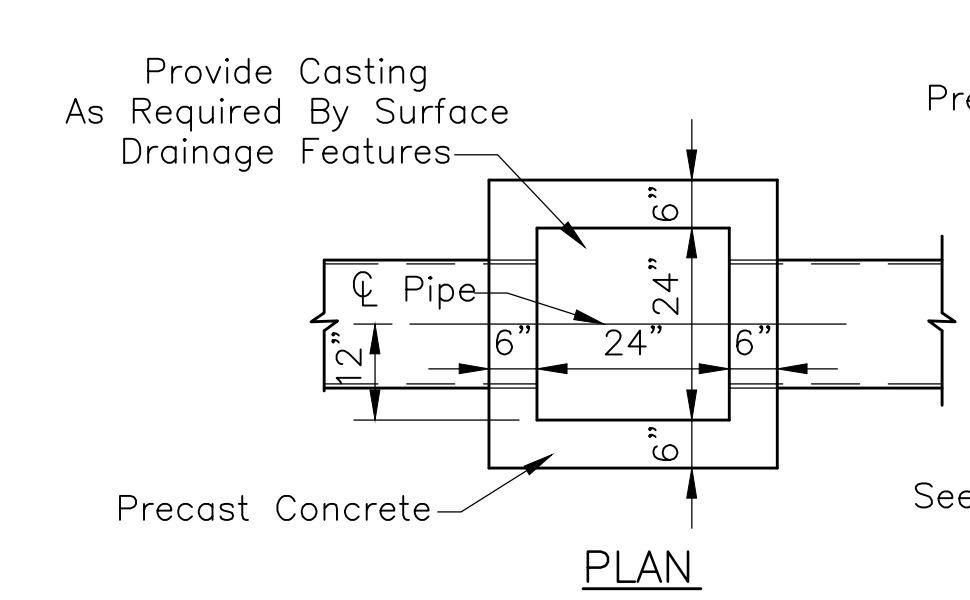

**CATCH BASIN, TYPE A**  
Scale: 1/2"=1'-0"

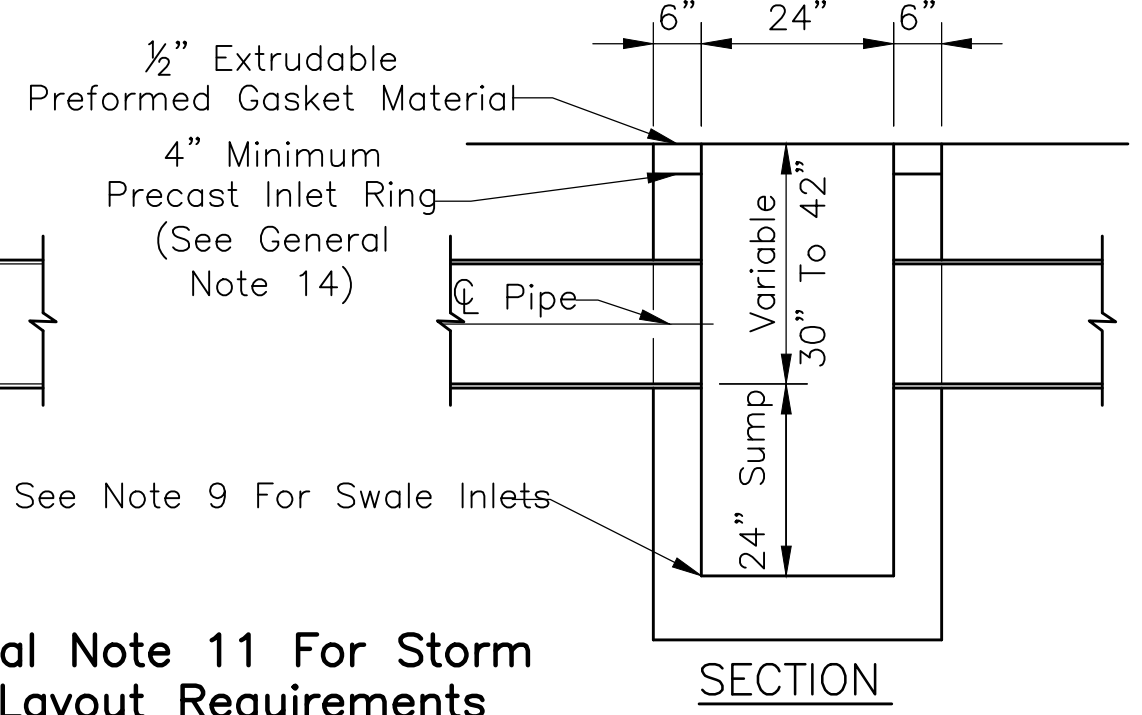

- GENERAL NOTES**
- Swales Shall Be Constructed With A Minimum 0.3 Percent Profile Grade Provided That A 6 Inch Diameter Underdrain Is Provided For Residential Swales And Commercial/Industrial Swales With Less Than A 0.5 Percent Profile Grade. See Detail On This Sheet.
  - Type J, K, L, M, N, And P Manholes As Detailed Hereon Require A Certain Minimum Depth. In Cases Where The Depth Of The Storm Sewer Is Not Sufficient To Meet The Minimum Depth As Required By The Detail, "F" Diameter Manhole Section May Be Used Throughout The Depth Of The Manhole.
  - Manholes Shall Conform To ASTM C478. Joints Shall Conform To ASTM C443. The Use Of Cast-In-Place Concrete Structures Shall Require The Prior Written Approval Of The Town Engineer. Regardless Of The Type Of Casting Used, The Casting Shall Be Centered Over The Manhole Steps.
  - Manhole Steps Shall Be Neenah R-1981-J, M.A. Industries PS 1-PF, Or As Approved By Plainfield DPW.
  - For Drainage Of Roll Curb And Gutter, Type I, Provide As Per Development Standard Detail DS-D01 Or As Approved By Plainfield DPW.
  - For Drainage Of Combined Curb And Gutter, Type II, Provide As Per Development Standard Detail DS-D02 Or As Approved By Plainfield DPW. For Additional Capacity As Directed By The Engineer, Provide As Per Development Standard Detail DS-D03 Or As Approved By Plainfield DPW. Manholes Shall NOT Directly Drain Type II Curb.
  - For Drainage Of Open Pavement Areas Without Curbing At An Inlet, Provide As Per Development Standard Detail DS-D04 Or As Approved By Plainfield DPW.
  - For Drainage Of Open Pavement Areas Without Curbing At A Manhole, Provide As Per Development Standard Detail DS-D05 Or As Approved By Plainfield DPW.
  - Castings For Use On Inlets Or Manholes Which Drain Swales Or Dry Bottom Detention Basins Shall Be As Per Development Standard Detail DS-D06 Or As Approved By Plainfield DPW.
  - Castings For Manholes Which Do Not Drain Surface Water Shall As Per Development Standard Detail DS-D07 Or As Approved By Plainfield DPW.
  - Mainline Pipe Shall NOT Connect To Catch Basins. Catch Basin Connections Occur At A Manhole. Mainline Pipe Is Any Pipe Downstream Of A Single Set Of Two Catch Basins Or Any Pipe Larger Than Or Equal To 15 Inch Diameter. Pipe Less Than Or Equal To 15 Inch Diameter Which Drains One Swale Inlet May Be Connected To Catch Basins When The Invert Depth Of Such Catch Basin Is Not Greater Than Shown On The Catch Basin Detail. A 10'-15' Offset Is Required For Inlet Pipes Parallel To Mainline Pipe. It Is Noted That On Commercial Sites No Pipe Is Considered Mainline Pipe Until It Enters The Public R-0-W. Further, On Commercial Sites Precast Concrete Structures, As Detailed By Outside Sources, May Be Used Subject To The Providing Of A Suitable Transition So That Castings Prescribed For Use Within Plainfield Are Used, And Subject To Storm Sewer General Note 4 On Sheet 7.
  - Catch Basins Require Back Plaster Inside And Out. Castings May Be Adjusted As Much As 1/2" Using Cretex PenngROUT Or As Approved By Plainfield DPW. Special Adjustment Up To 6" Using Precast Adjusting Ring With 1/2" Butyl Rubber Gasket May Be Used If Approved By Plainfield DPW.
  - All Castings Shall Be Per Sheet No. 10 Of The Town Standards.
  - All Inlets And Catch Basins Shall Have A Minimum Of 3" Allowed For Riser Rings Or Adjustment; Manholes Shall Have A Minimum Of 4".
  - When A Structure Encroaches Within 5' Of A Roadway, Or At The Discretion Of Plainfield DPW, It Shall Be Backfilled With #8 Stone.

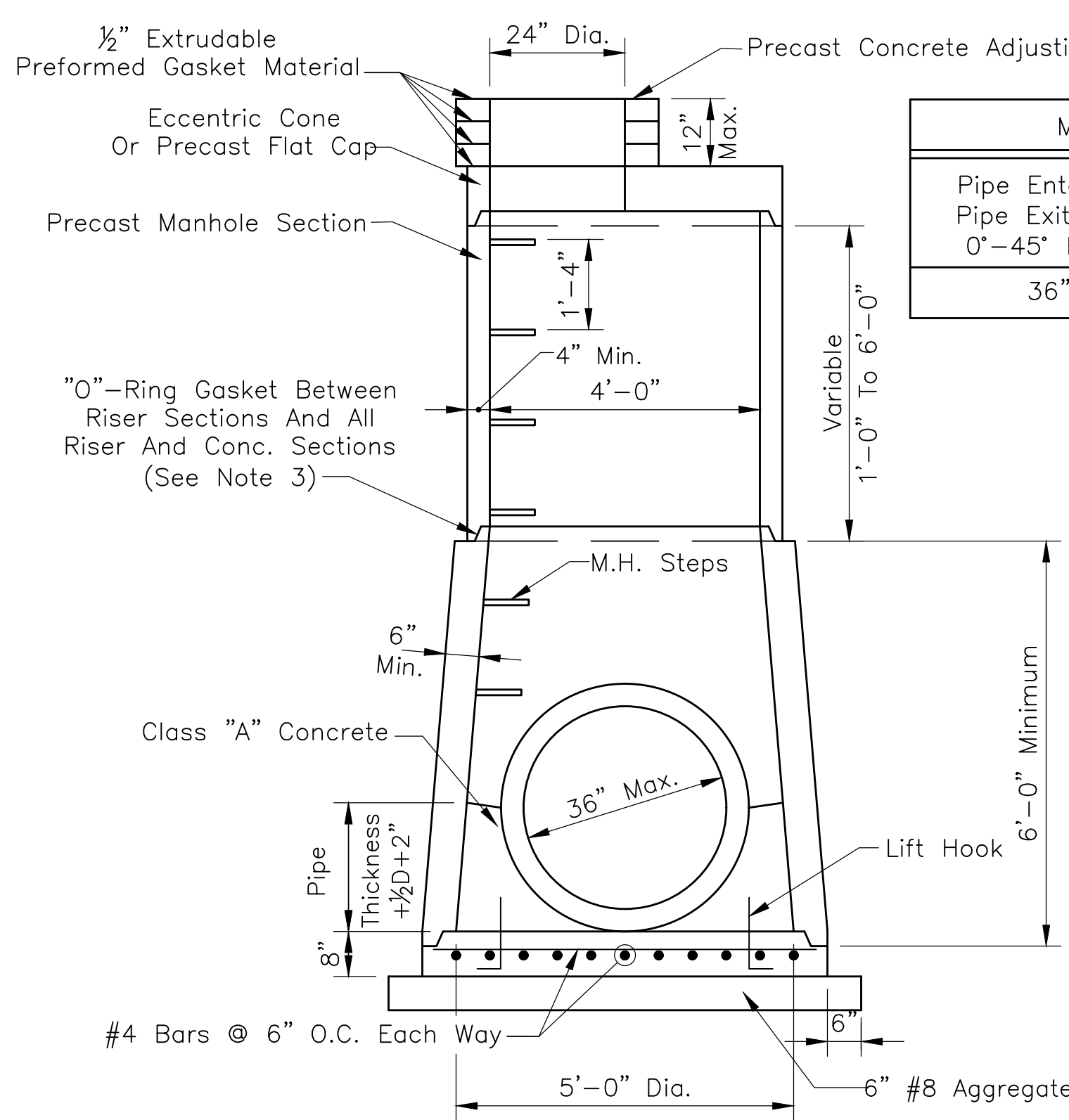

**MANHOLE TYPE H**  
Scale: 1/2"=1'-0"

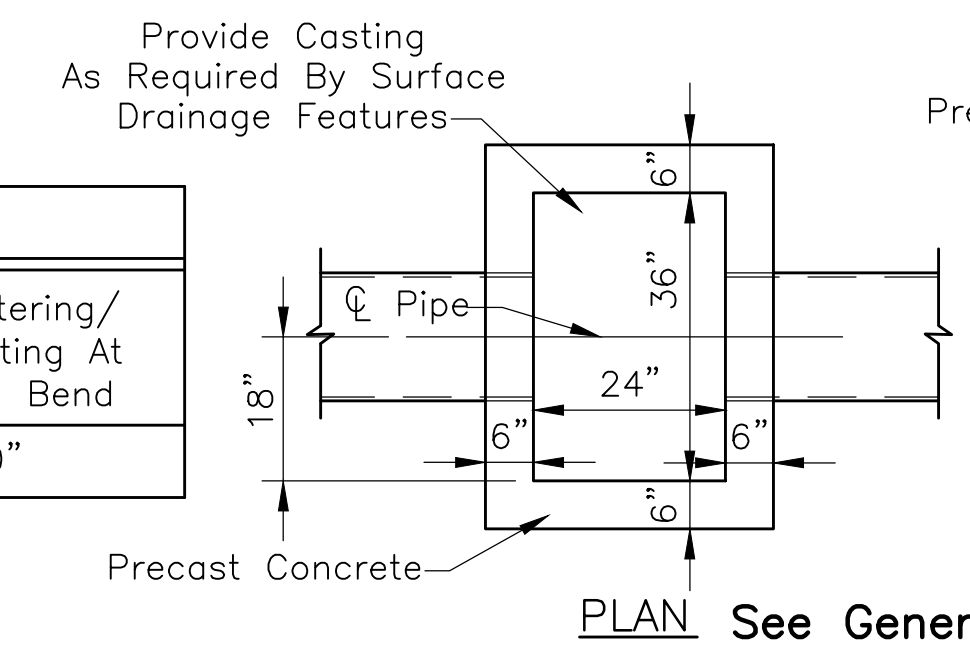

**CATCH BASIN, TYPE B**  
Scale: 1/2"=1'-0"

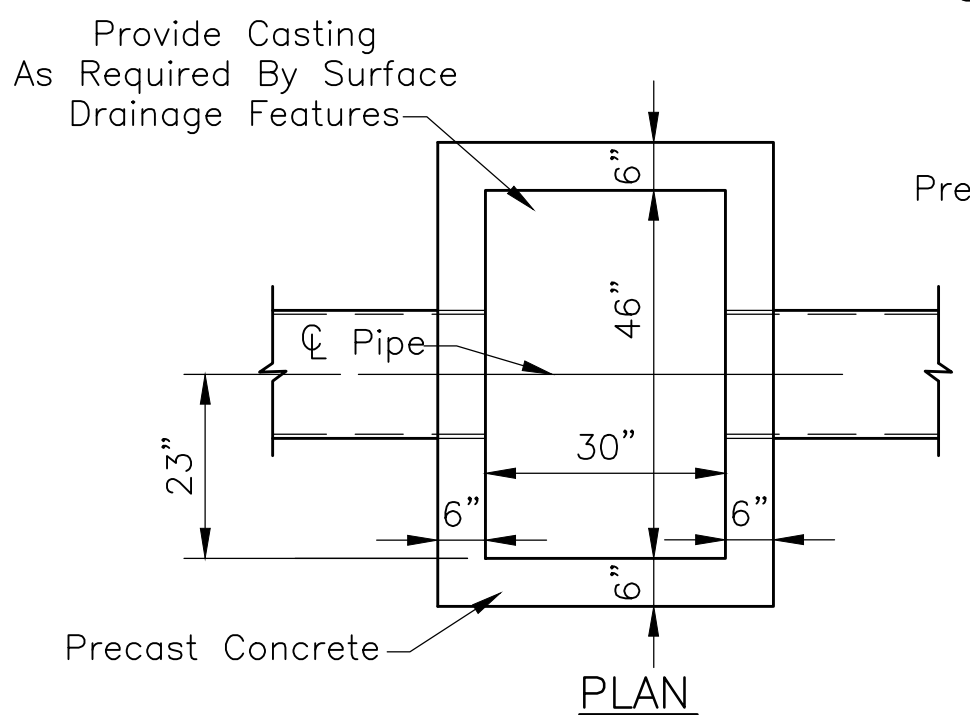
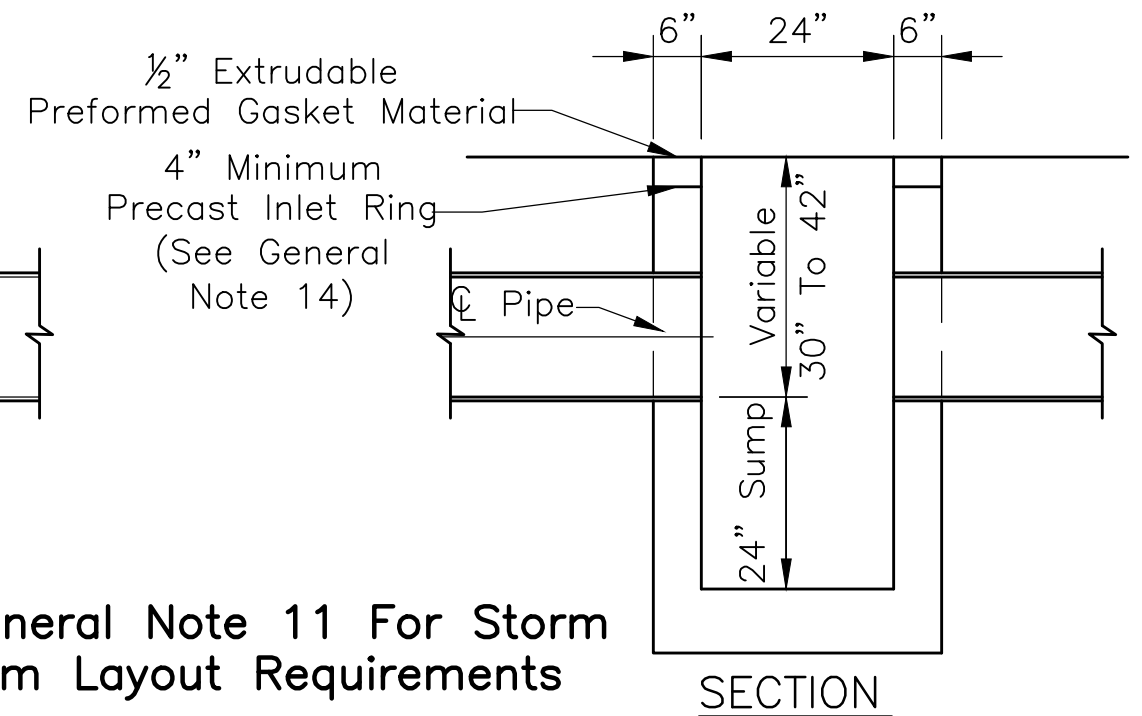

**CATCH BASIN, TYPE C**  
Scale: 1/2"=1'-0"

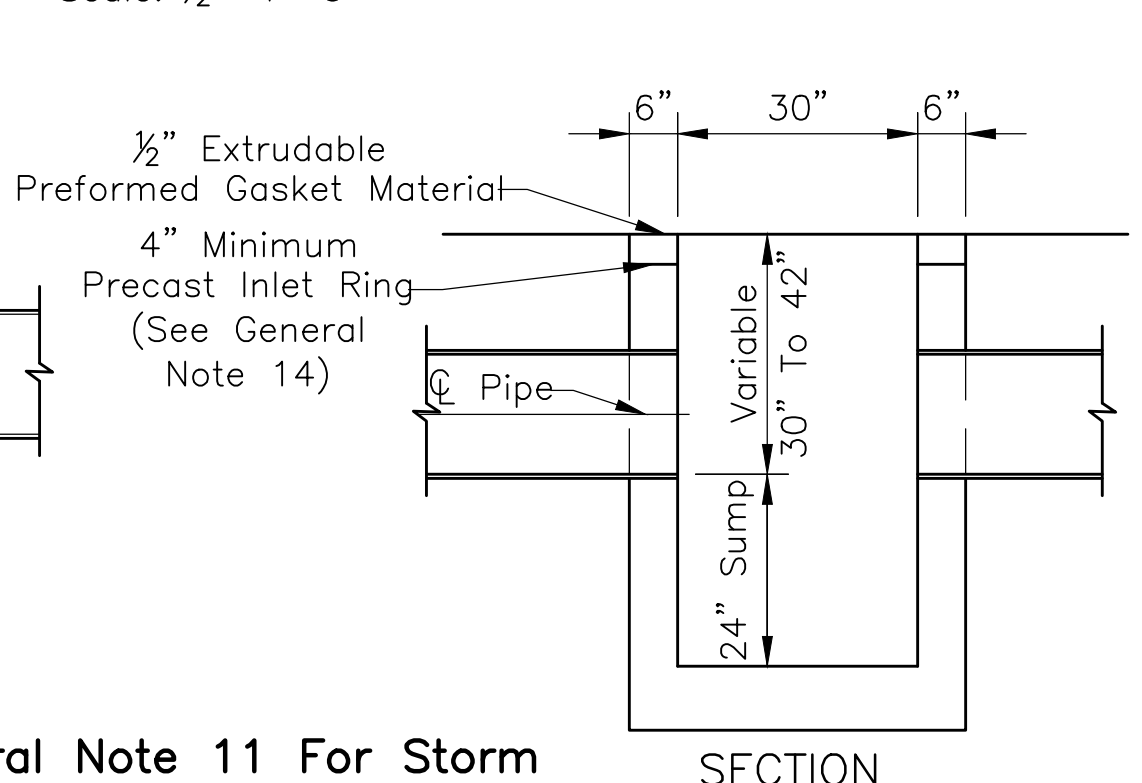

REVISIONS		
Rev. No.	Description	Date

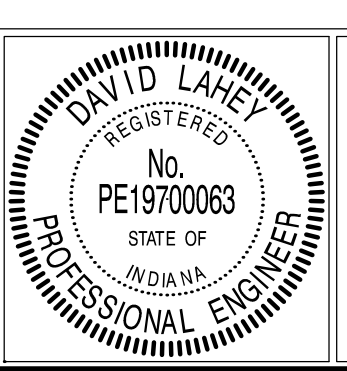

RECOMMENDED FOR APPROVAL: *David Loney*, DESIGN ENGINEER, DATE: 01/01/2019  
 APPROVED: *James Smith*, TOWN ENGINEER, DATE: 01/01/2019  
 APPROVED: *James Smith*, SUPERINTENDENT OF PUBLIC WORKS, DATE: 11/1/2019

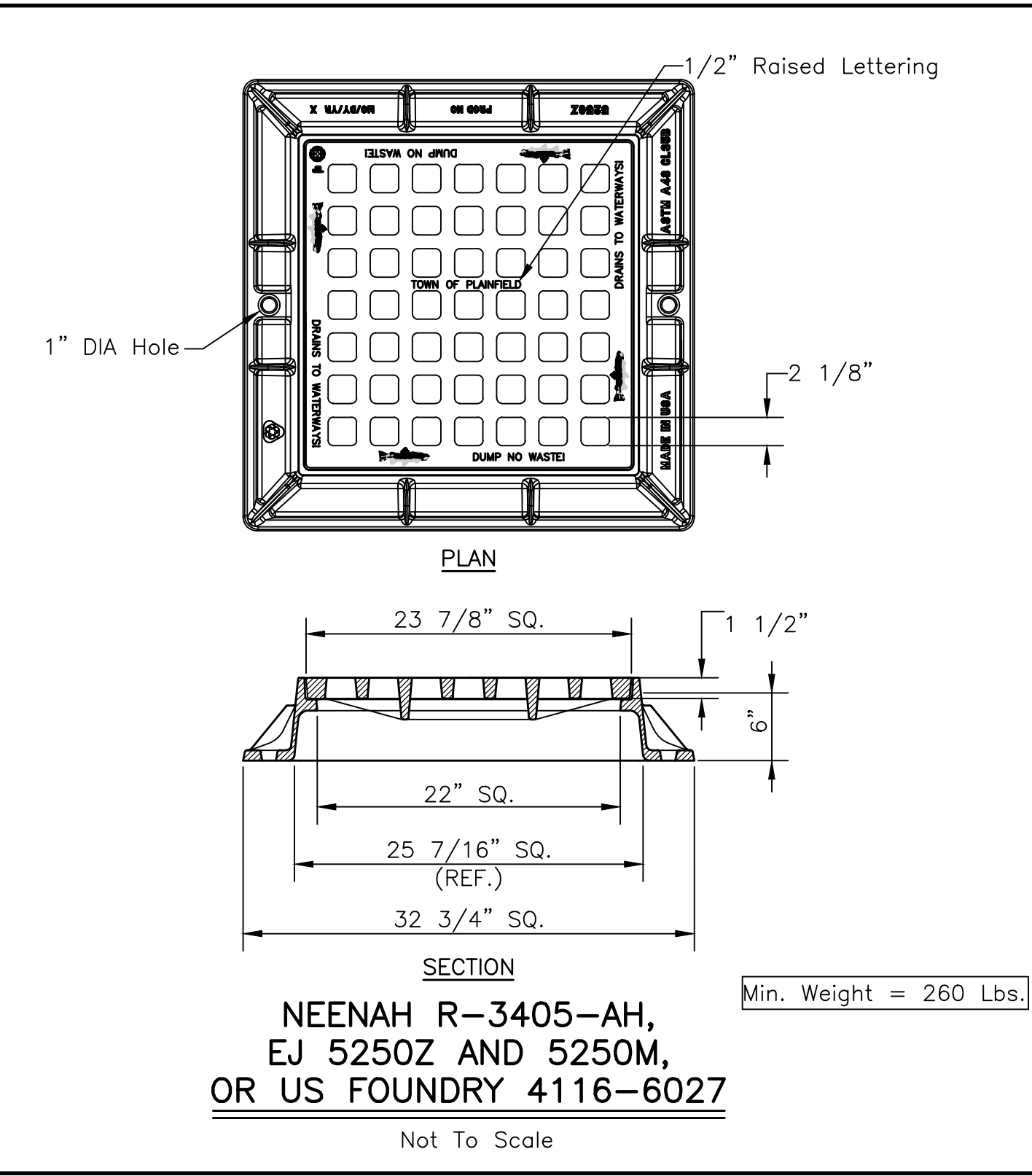
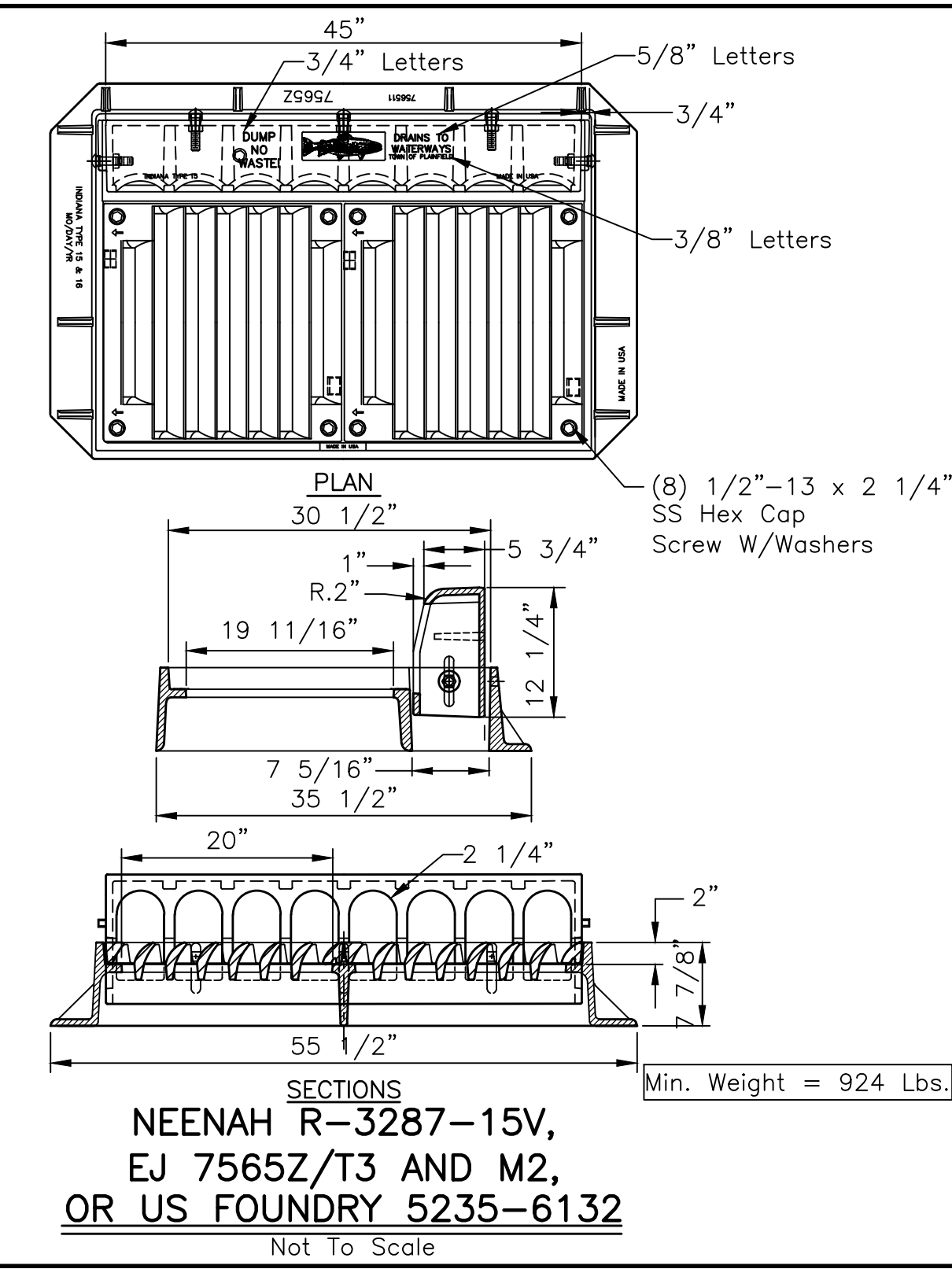
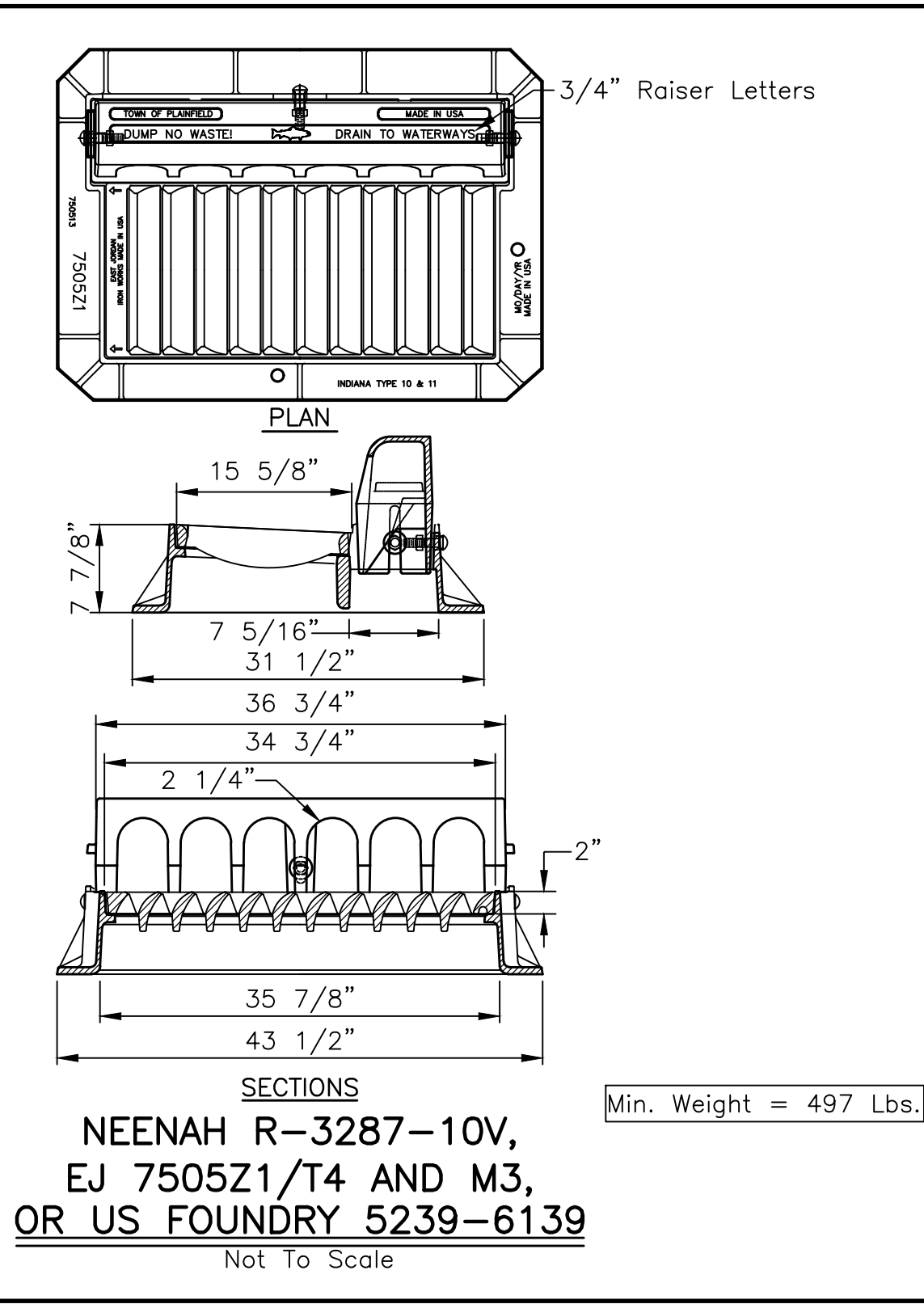
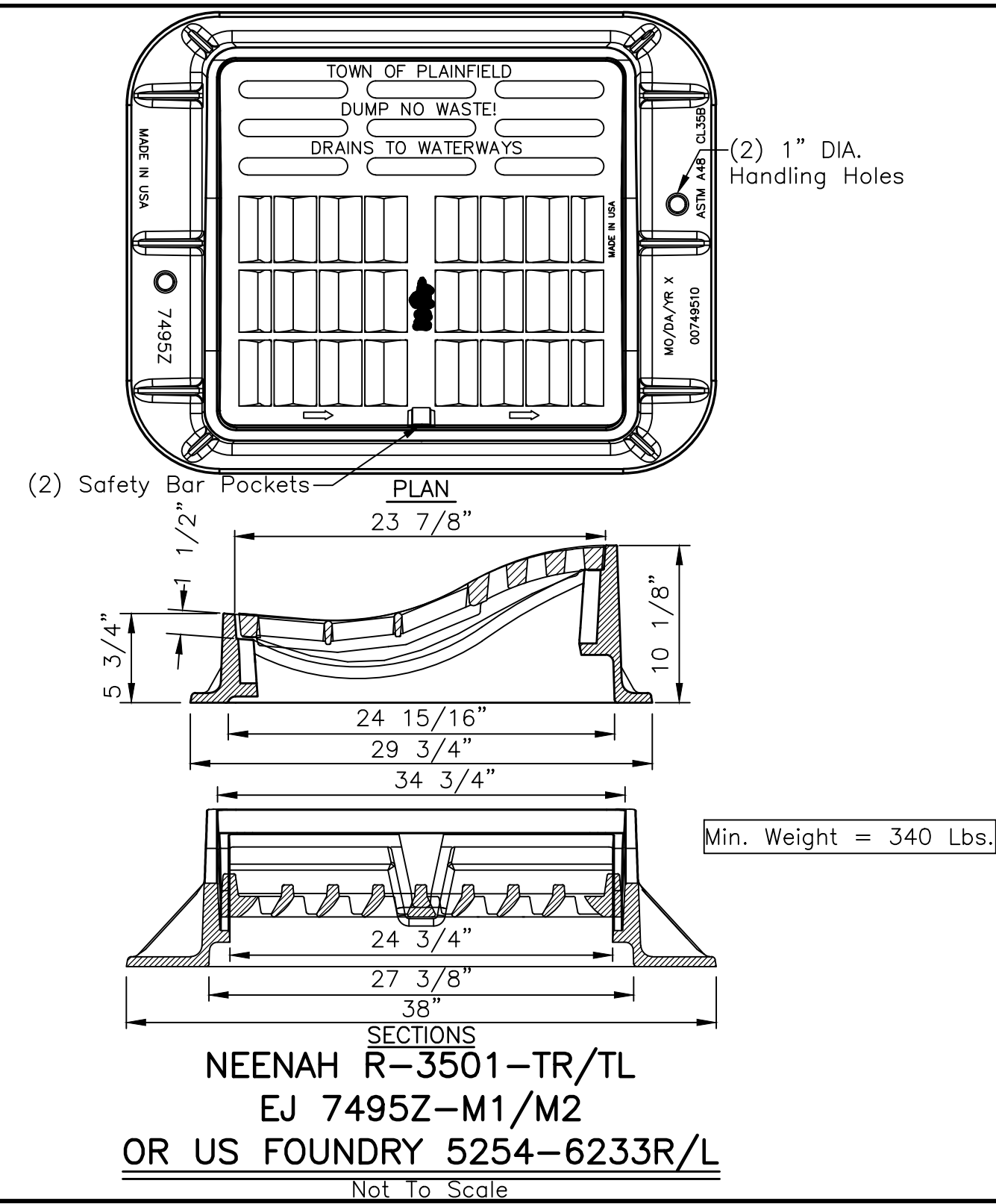

DEVELOPMENT STANDARD - DETAIL DS-D01

DEVELOPMENT STANDARD - DETAIL DS-D02

DEVELOPMENT STANDARD - DETAIL DS-D03

DEVELOPMENT STANDARD - DETAIL DS-D04

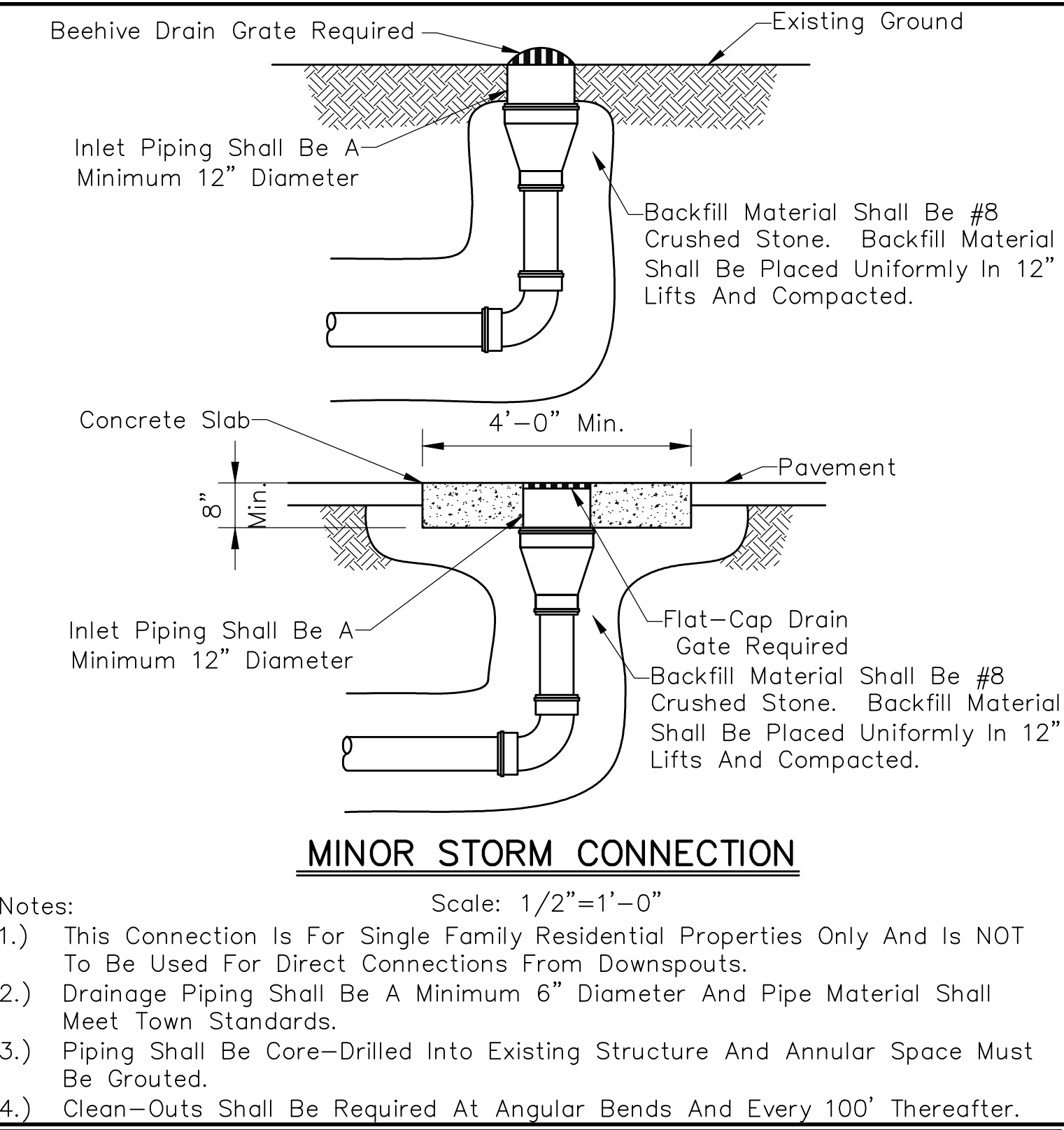
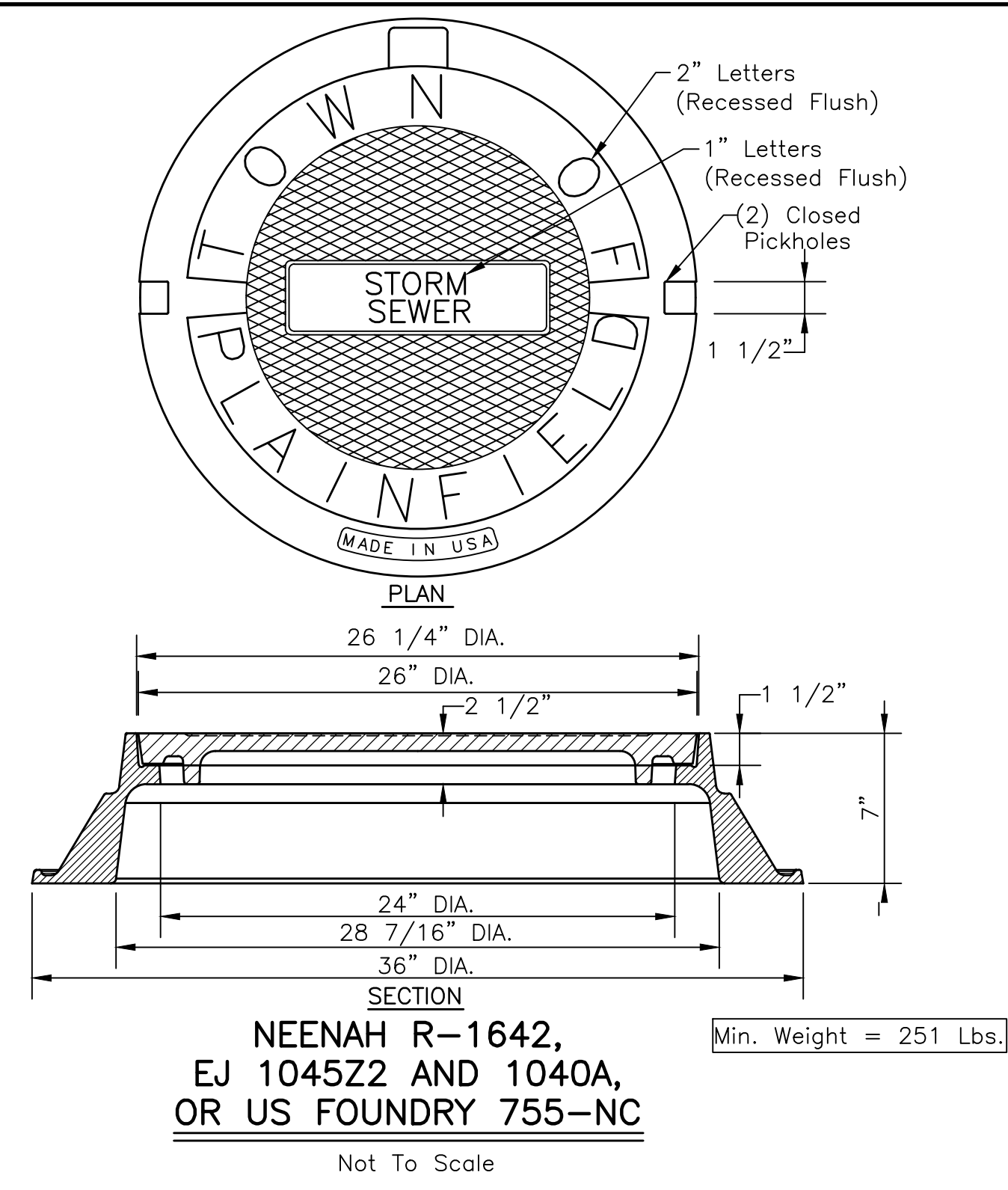
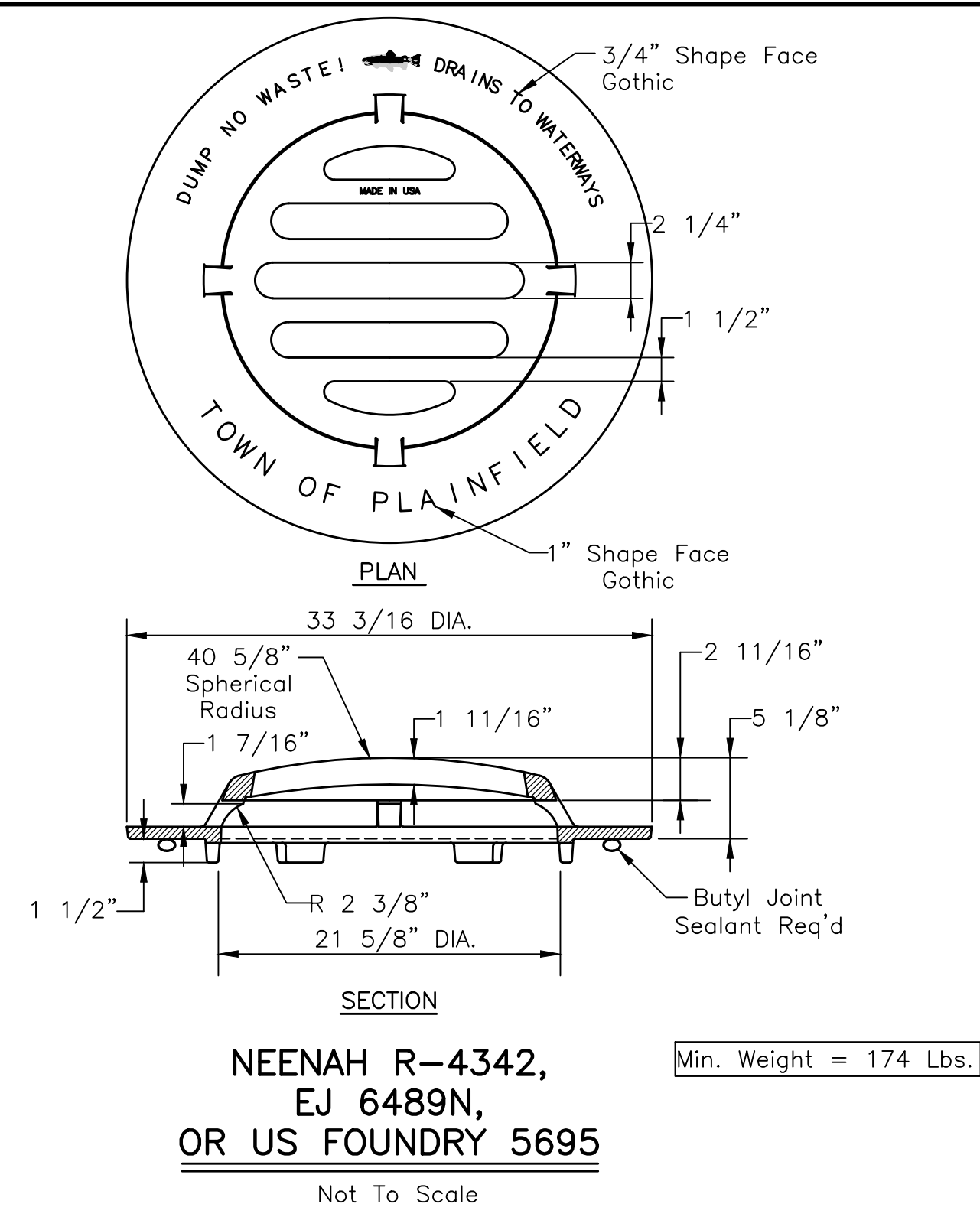
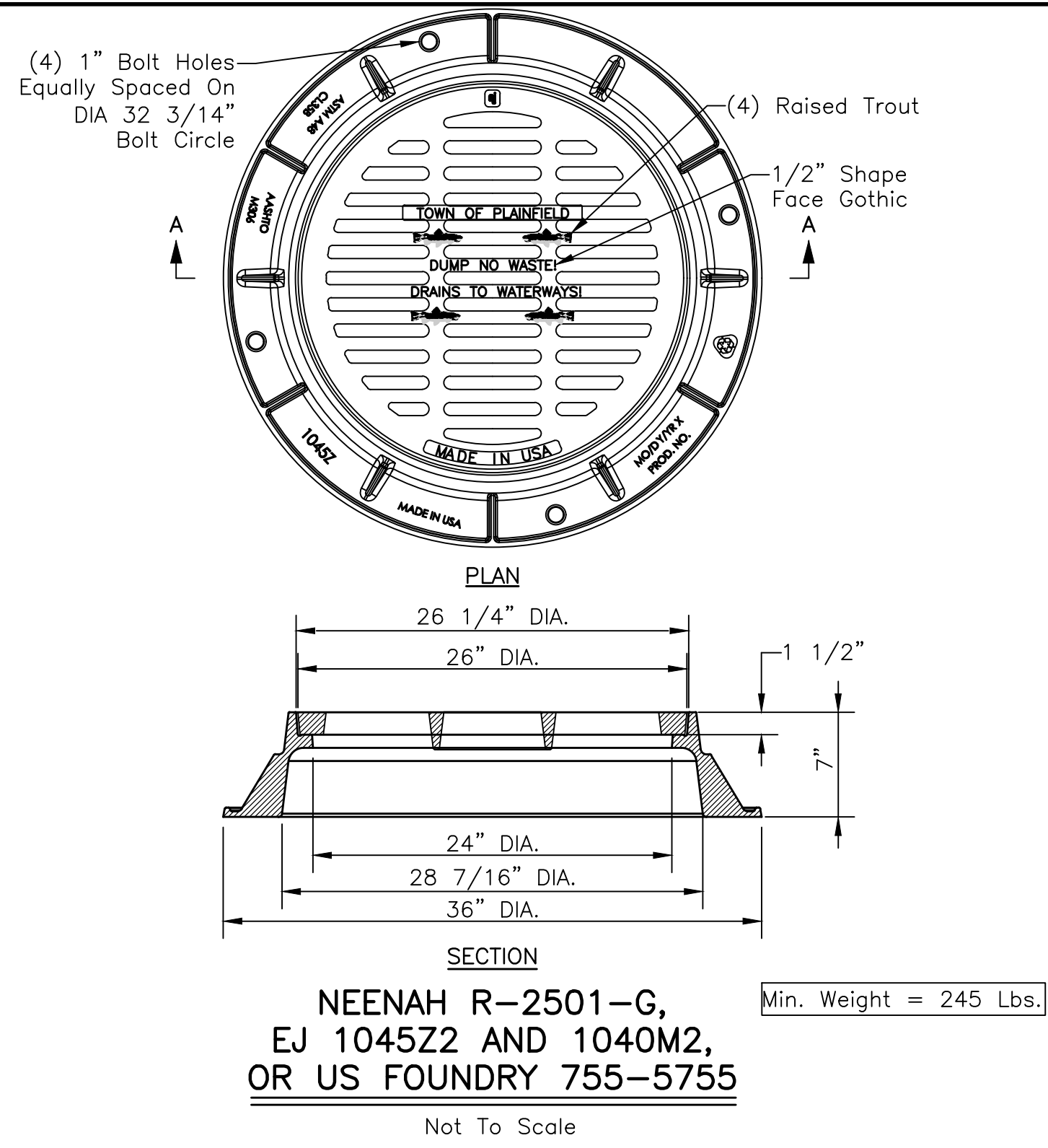

DEVELOPMENT STANDARD - DETAIL DS-D05

DEVELOPMENT STANDARD - DETAIL DS-D06

DEVELOPMENT STANDARD - DETAIL DS-D07

DEVELOPMENT STANDARD - DETAIL DS-D08

REVISIONS		
Rev. No.	Description	Date

RECOMMENDED FOR APPROVAL: *David Lahey* DESIGN ENGINEER 01/01/2019

APPROVED: *James Smith* TOWN ENGINEER 01/01/2019

APPROVED: *James Smith* SUPERINTENDENT OF PUBLIC WORKS 11/1/2019

**WATER MAIN MATERIALS**

- All Pipe Provided For Use In The Town Of Plainfield Water System Shall Be Of U.S. Production Manufactured By American, U.S. Pipe, Or Town Approved Equal. All Fittings Provided For Use In The Town Of Plainfield Water System Shall Be Of U.S. Production Manufactured By Clow, Tyler, American, Or As Approved By Plainfield DPW.
- Ductile Iron Pipe For Water Mains Shall Be Centrifugally Cast And Shall Conform To The Latest Revision Of ANSI A21.5 And AWWA C151. Ductile Iron Pipe With Push-On Or Mechanical Joints Shall Be Special Thickness Class 50. The Pipe Shall Be Provided With A Minimum Laying Length Of 18 Feet.
- Ductile Iron Fittings 3 Inches Through 48 Inches Shall Conform To The Latest Revision Of ANSI A21.10 And AWWA C110. Ductile Iron Compact Fittings 3 Inches Through 16 Inches Shall Conform To The Latest Revision Of ANSI A21.53 And AWWA C153. Fittings In, And Within 2 Feet Of, Structures Shall Be Flanged. All Other Fittings Shall Be Mechanical Joint Type.
- Ductile Iron Pipe Coatings Shall Conform To The Latest Revision Of ANSI A21.51, AWWA C151, ANSI A21.4, And AWWA C104. Interior Pipe Lining Shall Be Cementitious Mortar With Asphaltic Seal Coat. Exterior Pipe Coating Shall Be Standard Asphaltic Coating, Except Exposed Piping Within Structures Shall Receive Shop Priming Compatible With Finish Coat.
- Mechanical Joints And Accessories Shall Conform To The Latest Revision Of ANSI A21.10 And AWWA C110. Rubber Gaskets Shall Be Vulcanized Synthetic Rubber And Shall Conform To The Latest Revision Of ANSI A21.11 And AWWA C111.
- Flanged Joints Shall Conform To The Latest Revision Of ANSI A21.15 And AWWA C115. Rubber Gaskets Shall Be Either Ring Or Full Face And Shall Be 1/8" Thick. Bolts And Nuts Shall Conform To ANSI B18.2.1 And ANSI B18.2.2.
- Push-On Joints Shall Conform To The Latest Revision Of ANSI A21.11 And AWWA C111. Rubber Gaskets Shall Be Vulcanized Synthetic Rubber And Shall Conform To The Latest Revision Of ANSI A21.11 And AWWA C111.
- Service Tubing To Customer Shall Be Copper Water Tube, Type K, Soft Temper For 3/4" Through 2" For Underground Service, Conforming To ASTM B88, ASTM B251, And AWWA C800. Pipe Shall Be Marked With The Manufacturer's Name Or Trademark And Mark Indicative Of The Type Of Pipe. Outside Diameter Of The Pipe And Minimum Weight Per Foot Of Pipe Shall Not Be Less Than Listed In ASTM B251, Table II.
- Gate Valves Shall Be In Accordance With AWWA C509 Having Fused Epoxy Coating Inside And Outside Assembled With S.S. Bolts And Shall Be American Flow Control Series 2500. Consult Plainfield DPW For Valves Larger Than 16 Inches. Valves Shall Pass A 300 PSI Factory Test. Valve Boxes Shall Be Furnished With Posi-Caps To Align Box Over Stem.

**WATER MAIN PRESSURE AND LEAKAGE TESTING**

- The Town Of Plainfield Shall Be Given 24 Hour Written Notice Of The Required Pressure And Leakage Test To Be Performed By The Contractor. The Pressure And Leakage Test Shall Be Performed In Accordance With The Basic Provisions Of AWWA C600. The Testing Procedure Shall Assume A 100 PSIG Working Pressure. The Test Pressure Shall Not Be Less Than 1.25 Times The Working Pressure At The Highest Point Along The Test Section But Not Less Than 1.5 Times The Assumed Working Pressure At The Point Of Testing. Test Pressure Shall Not Exceed Pipe Or Thrust Restraint Design Pressures Or Rated Pressure Of The Valves. The Test Pressure Shall Not Vary By More Than +5 PSI For The 2 Hour Test Duration.
- Valves Shall Not Be Operated In Either Direction At Differential Pressures Exceeding The Rated Valve Working Pressure.
- The Pressure And Leakage Test Shall Be Performed Following The General Form Of The Following:
  - Record Time And Line Pressure Prior To Start Of Test.
  - Pump Water Into New Main Until Pressure Reaches 150 PSIG, Stop Pumping When Pressure Reaches 150 PSIG, Record Time And Line Pressure.
  - Contractor Shall Remain At Site For One Hour. The Test Shall Be Voided If Any Adjustments Are Made To The Main, Test Equipment, Or Appurtenances. Tightening Of Fittings On Test Equipment Is Allowed. Following The One Hour Period, Record Time And Line Pressure.
  - Pump Water Into New Main From A Calibrated Container Of Water Until Pressure Reaches 150 PSIG, Stop Pumping When Pressure Reaches 150 PSIG, Record Time, Line Pressure, And Amount Of Water Pumped To The Nearest 1/100 Gallon. The Calibrated Container Shall Have Markings At 1/10 Gallon Increments.
  - Repeat Steps C And D One Additional Time.
- A Test Section Of Water Main Is Considered Satisfactory If It Meets The Following:

Main Size (Inches)	Allowable Leakage (Gal./Hr./1000 Ft.)
6	0.50
8	0.66
10	0.83
12	0.99
16	1.32

- If The Leakage From A Test Section Is Greater Than Permitted Under These Specifications, The Contractor Shall Locate And Repair The Defective Joints, Mains, And Appurtenances. The Pressure And Leakage Test Shall Then Be Repeated Until Satisfactory Results Are Obtained. All Labor And Materials Required To Meet The Requirements Of The Pressure And Leakage Test Shall Be At The Expense Of The Contractor.

**WATER MAIN GENERAL NOTES**

- Provide A Valve On All Runs And Branches Per The Connection Details On Sheet 12 Of The Plainfield Standards Even When Such Runs Or Branches Are Stubs For Future Extension.
- Storm Pipe Conflicts Require Special Attention In That Proposed Water Mains Shall Pass Over Proposed Mainline Storm Pipe. Such Situations May Require Upsizing Of Downstream Storm Pipes To Enable Flatter Slopes To The Point Of Conflict Such That 30 Inch Minimum Cover Is Maintained Over The Water Main. Vertical Water Main Fittings Shall Not Be Used. All Water Main Crossings Of Storm Pipe Shall Be Shown On Storm Sewer Profiles. When It Is Necessary To Decrease Water Main Cover To Less Than 54 Inches, Inlet Pipes That May Conflict With The Water Main Shall Be Laid At Such Slope To Pass Below The Water Main.
- Water Mains Shall Follow The Alignment Of The Road Centerline And Shall Remain 3 1/2 Feet Behind The Back Of Curb On One Side Of The Street Without Alternating From Such Side.
- All Water Pipe Shall Be Installed In Accordance With AWWA C600 And With A Minimum Depth Of Cover Of 54 Inches, Except As Provided By General Note No. 2.
- Terminate Dead End Mains With A Mainline Valve Followed By A Fire Hydrant Assembly. For Cul-De-Sacs, Eliminate Hydrant Assembly Tee And Terminate With 6" Valve And Fire Hydrant As Directed Or Approved By The Plainfield DPW, Terminate Temporary Dead End Mains With A #2 Eclipse Post Hydrant With Tamper-Proof Options And Provide #492 Tamper-Proof Wrench With A Brass Street Elbow, Brass Nipple, Mueller B20283 Ball Curb Valve With Box, And A Brass Nipple Tapped Into Restrained Cap. See Development Standard DS-W05.
- Unless Unavoidable As Determined By Plainfield DPW, Double Tees Shall Not Be Permitted. Utilize A Cross At Intersection Of Four Water Mains With Cross Sized To Match The Largest Pipe.
- See Development Standard DS-W01 For Water Main Abandonment Procedure.

**WATER MAIN DISINFECTION, BACTERIOLOGICAL TESTING AND AS-BUILT DRAWINGS**

- The Town Of Plainfield Shall Be Given 24 Hour Written Notice Of The Required Disinfection, Flushing And Testing Procedures To Be Performed By The Contractor. All Newly Installed Water Mains Shall Be Disinfected In Accordance With ANSI/AWWA C-651. Liquid Chlorine, High-Test Calcium Hypochlorite (70 Percent Chlorine), Or High-Test Sodium Hypochlorite (14.7 Percent Chlorine) May Be Used To Provide An Initial Minimum Concentration Of 25 mg/L Of Free Chlorine In All Newly Installed Mains.
- A Minimum Concentration Of 10 mg/L Of Free Chlorine Shall Be Maintained In All Parts Of The Newly Installed Mains For 24 Hours Of Contact Time.
- Following The Initial 24 Hour Contact Time But Prior To 48 Hours Of Contact Time, All Treated Water Shall Be Properly Dechlorinated and Thoroughly Flushed From The Newly Laid Pipe At Its Extremity Until The Replacement Water Has A Chlorine Residual Of Less Than 1 mg/L.
- After Flushing, Water Samples Collected On Two Successive Days From The Treated Piping System, As Directed By The Town Of Plainfield, Shall Show Satisfactory Bacteriological Tests. Following Satisfactory Bacteriological Tests, Contractor Shall Submit 2 Copies Of The Results To Plainfield DPW And To IDEM Drinking Water Branch.
- The Taking Of Samples And The Testing Of Chlorine Residual Shall Be Carried Out By The Contractor At The Direction Of The Town Of Plainfield.
- As-Built Drawings Shall Be Submitted To Plainfield DPW.

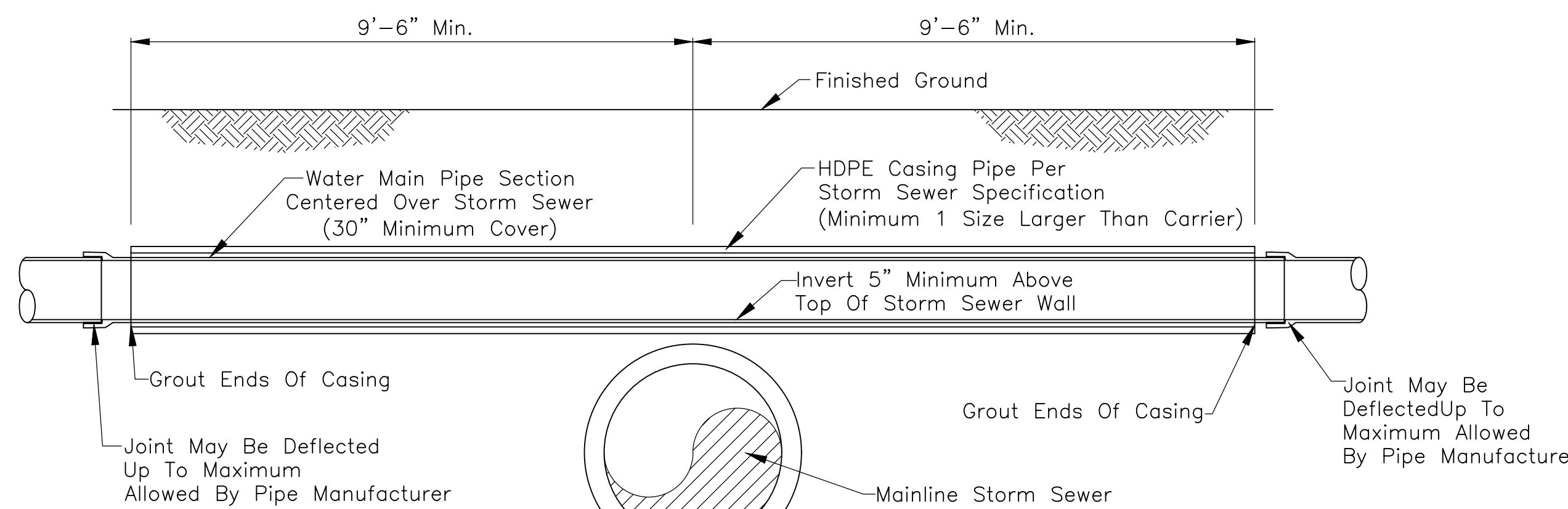

HDPE Casing Pipe Required At All Water Main/Sewer Crossings Which Violate The 18 Inch Minimum Vertical Separation Required By Ten States Standards. Refer To Water Main General Notes.

**SPECIAL STORM SEWER CONFLICT TREATMENT**

Scale: None

Finished Ground; However, Installer Shall Coordinate Grade To Ensure Proper Pavement Section Or To Allow Placement Of Approved Loam Material To A Depth Of 8" For Seeding Or Sodding.

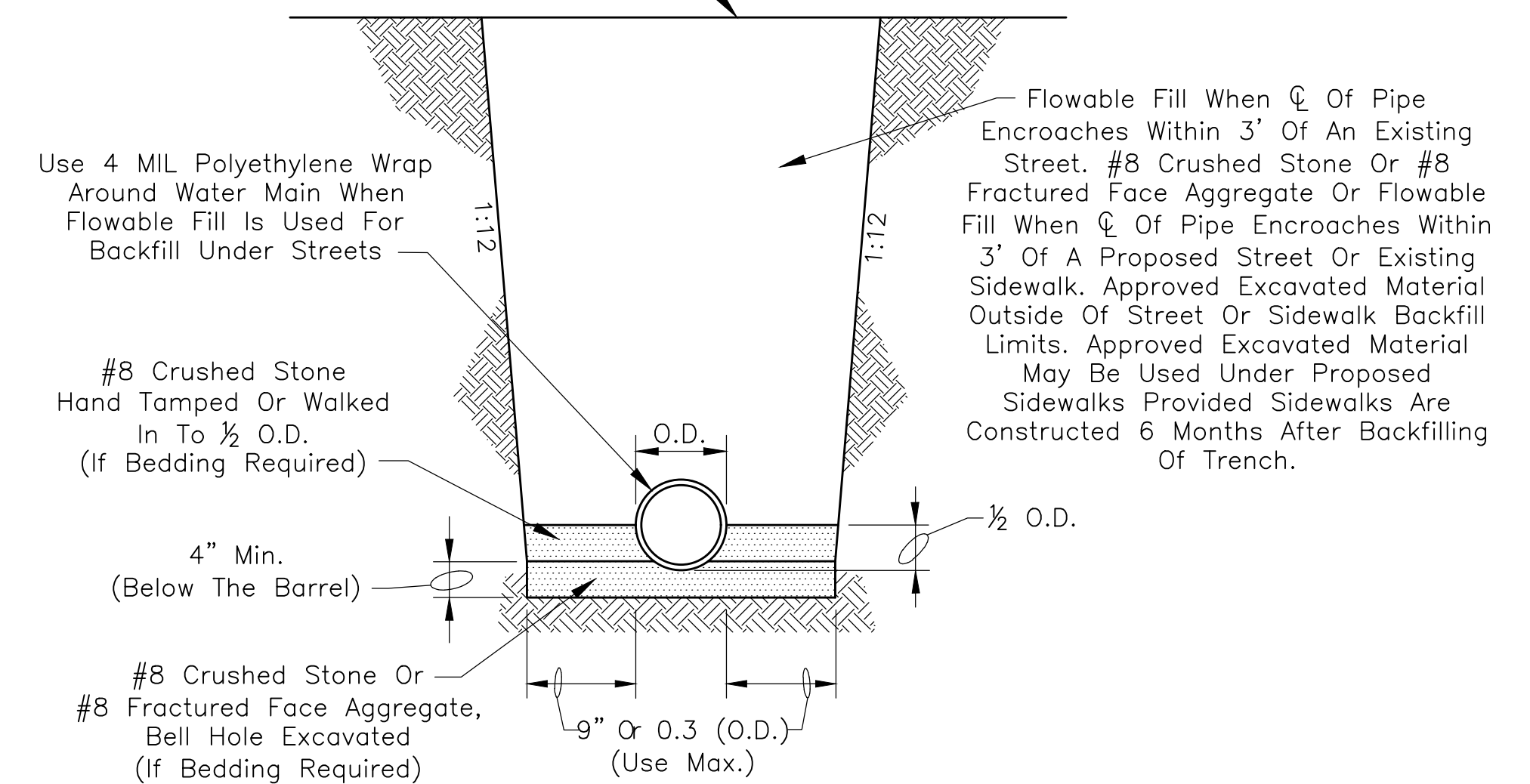

D.I. PIPE BEDDING TABLE		
Pipe Size (in)	Bedding Depth Below Barrel (in)	Cubic Yards Of Bedding Per Foot Of Pipe (cys/ft)
4	4	0.038
6	4	0.053
8	4	0.070
10	4	0.088
12	4	0.108
14	4	0.131
16	5	0.164
18	5	0.191
20	6	0.230
24	7	0.306
30	8	0.432

Note: Bedding Is Still Required Where Pipe Requires Structural Backfill (Flowable, #8, Etc.)

Experience Of Plainfield DPW Has Been That Bedding Has Not Been Required For Nearly All Installations. However, Plainfield DPW May Direct That Bedding Is Required As Trench Conditions Dictate. Therefore, It Is Recommended That The Project Owner And The Project Contractor Come To Agreement On Payment Methods In The Event That Bedding Is Required. The DI PIPE BEDDING TABLE IS A USEFUL TOOL FOR SUCH A PURPOSE.

**DI PIPE BEDDING DETAIL**

Scale: None

REVISIONS		
Rev. No.	Description	Date

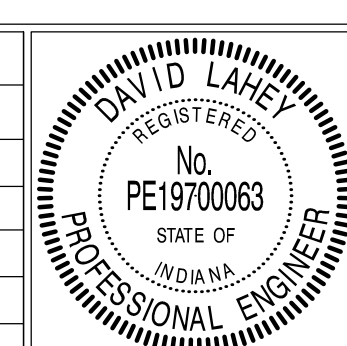

RECOMMENDED FOR APPROVAL	<i>David Laney</i>	DATE	01/01/2019
DESIGN ENGINEER			
APPROVED	<i>James Smith</i>	DATE	01/01/2019
TOWN ENGINEER			
APPROVED	<i>James Smith</i>	DATE	11/1/2019
SUPERINTENDENT OF PUBLIC WORKS			

TOWN OF PLAINFIELD
WATER MAIN BEDDING DETAILS AND NOTES

SHEET
11
OF
25

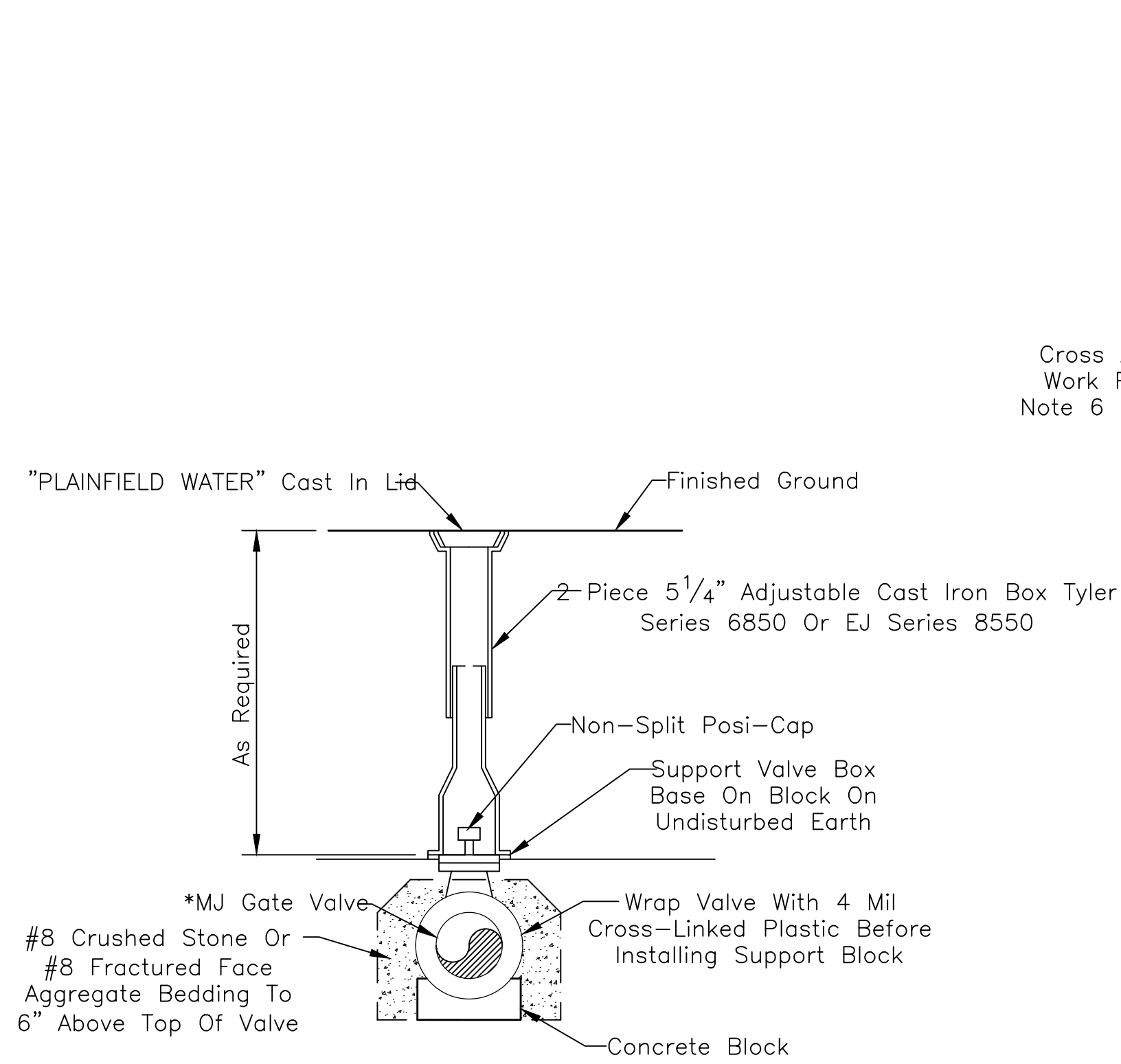

**TYPICAL VALVE INSTALLATION DETAIL**

Scale: None

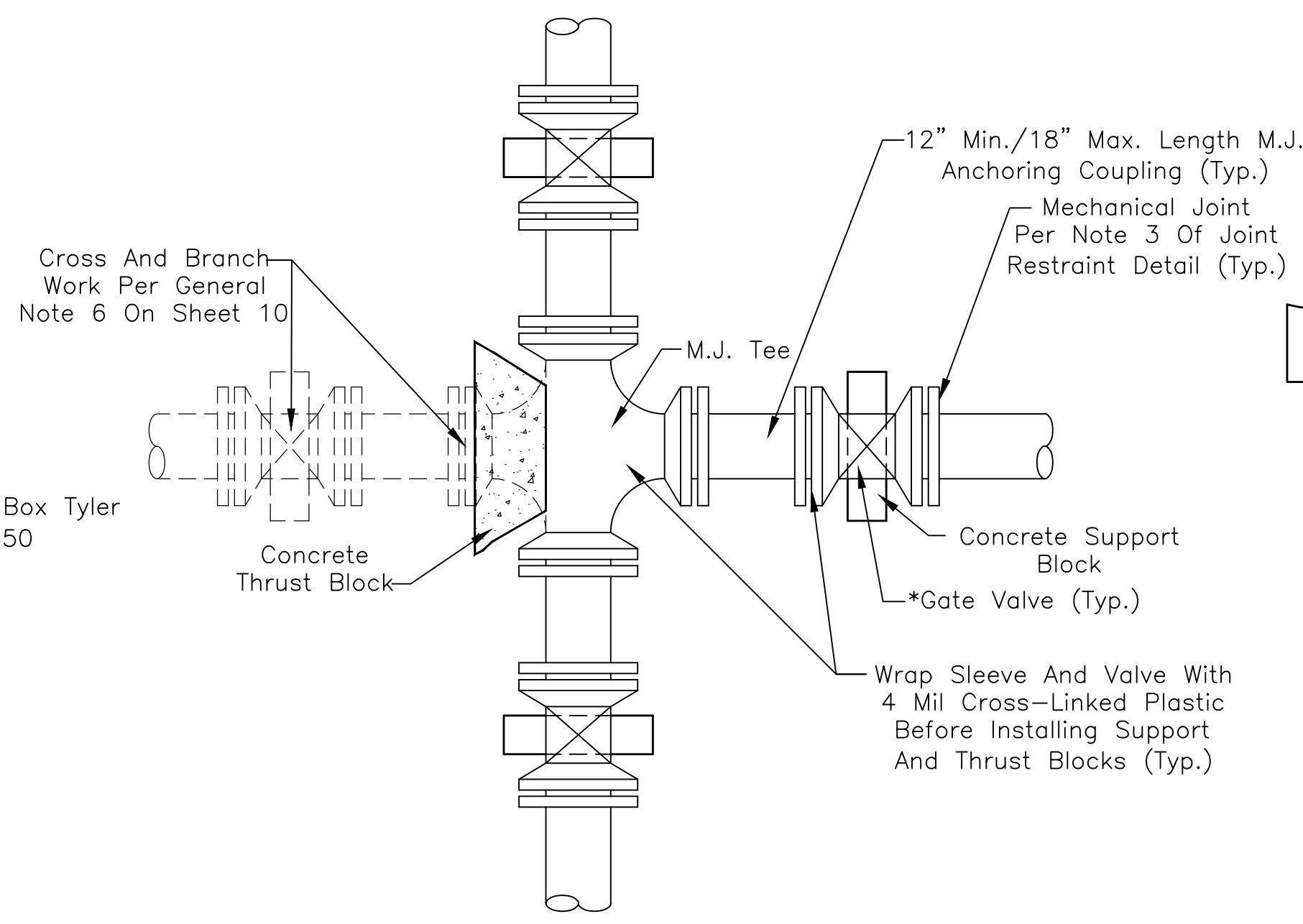

**STANDARD NEW WORK BRANCH CONNECTION**

Scale: None

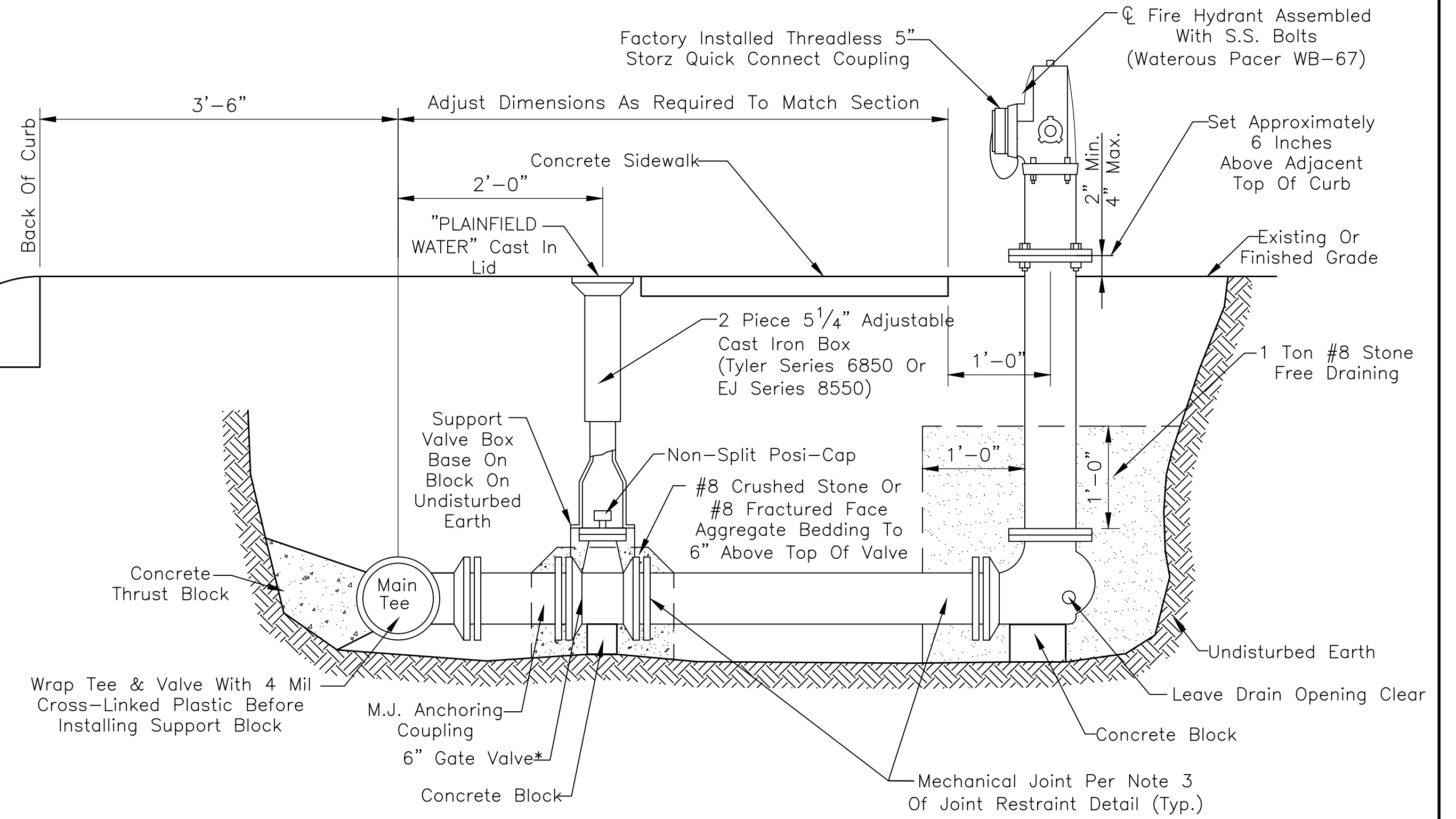

Note: Fire Hydrants Shall Be Painted Safety Yellow If Placed Behind Private Distribution Vault

**TYPICAL HYDRANT INSTALLATION DETAIL**

Scale: None

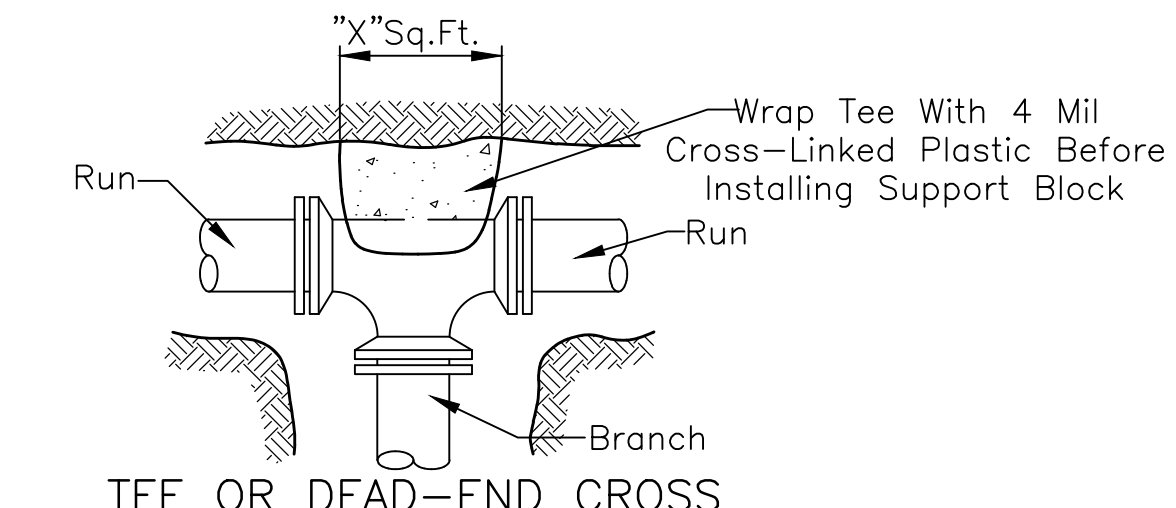

**TEE OR DEAD-END CROSS**

MINIMUM LENGTH OF RESTRAINED JOINT D.I. PIPE (WITHOUT POLY WRAP) EACH SIDE OF FITTING (FEET)	
PIPE SIZE	6" 8" 12" 16"
Tee Including Thrust Block (See Note)	15 20 28 36
Horizontal 90° OR Vertical 45° Down	15 20 28 36
Horizontal 45° OR Vertical 22½° Down	6 8 11 15
Horizontal 22½° OR Vertical 11¼° Down	3 4 6 7
Horizontal 11¼°	2 2 3 3
Dead End	27 35 50 65

**NOTES:**

- Length Of Restraint Measured From Centerline Of Fitting Requiring Restraint. Length Of Restraint For Vertical Bends Up Are Equal To That For Horizontal Bends.
- Length Of Restraint Based Upon 4'-6" Cover, 150 PSI Pressure, And ASTM D2487 Soil Types CL, ML, SC, SM, SP, SW, GC, GM, GP, & GW. For Less Cover, Higher Pressure, Or ASTM D2487 Soil Types PT, OH, CH, MH, & OL, Consult Plainfield DPW.
- Restraint To Be Accomplished With Field-Lok Gasket As Manufactured By U.S. Pipe Or Fast-Grip Gaskets As Manufactured By American For Push-On Joints, Anchoring Coupling For Valves And Adjacent Tees, Romac Grip Ring For All Mechanical Joints, Or As Approved By Plainfield DPW. Romac Grip Ring May Be Deleted On The Runs Of Hydrant Tees Unless A Mainline Valve Is Within 18 Feet Of The Hydrant Tee Or Unless Hydrant Tee Is Within Another Fitting's Restraint Length. All Restraints Shall Be Of U.S. Production.
- Tees And Dead-End Crosses Require Concrete Thrust Blocks In Addition To Branch Restraint Length, "X" Area For Concrete Thrust Blocks Per Detail Shall Be As Follows; 2, 4, 6, And 10 Square Feet For 6, 8, 12, And 16 Inch Pipe, Respectively. Other Than Restraint Of MJ Fittings Adjacent To Tee, No Run Restraint Length Is Required.

**JOINT RESTRAINT DETAIL**

Scale: None

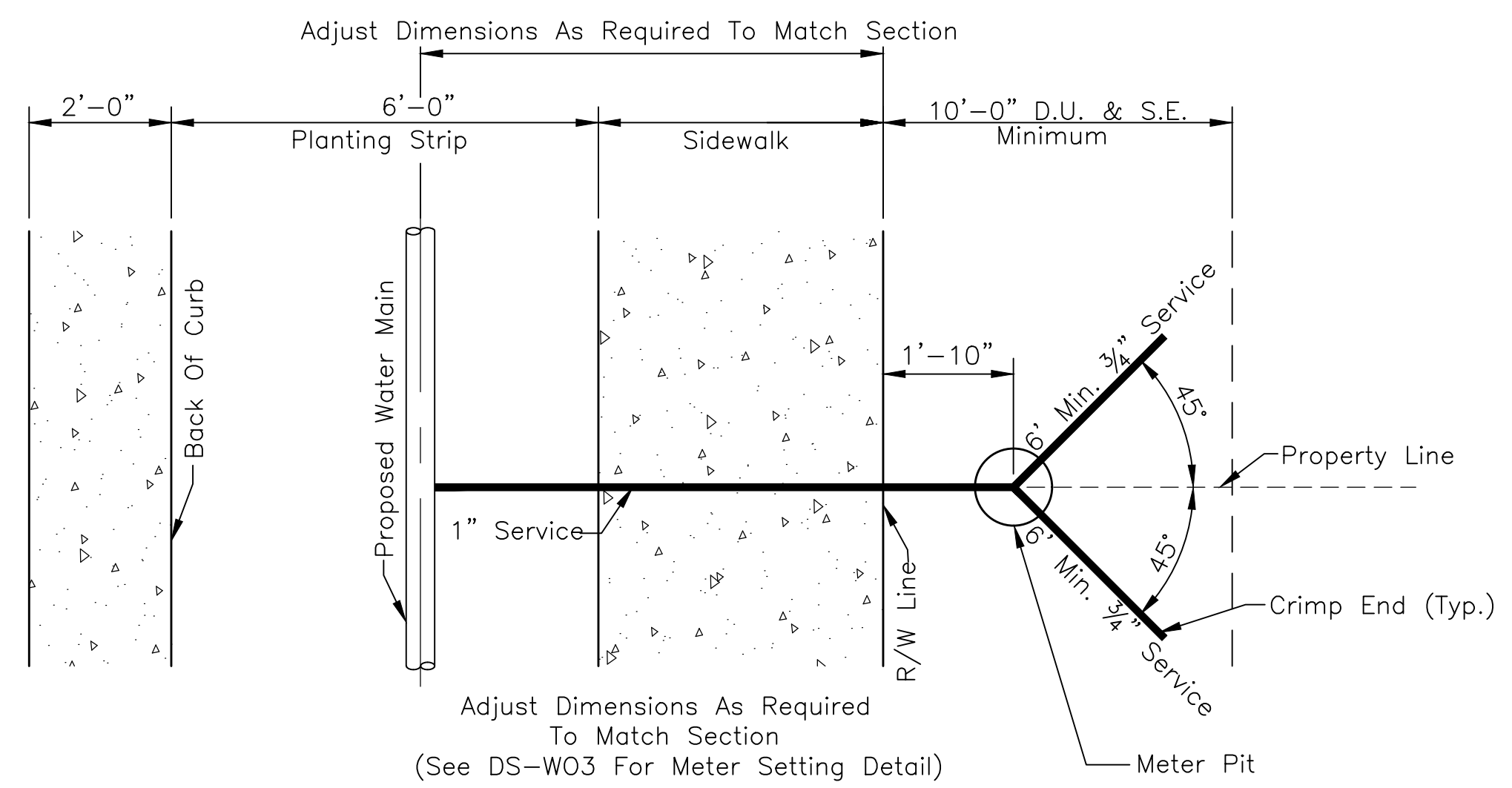

**TYPICAL DUAL METER SETTING DETAIL**

Scale: None

\* All Gate Valves Shall Be American Flow Control Series 2500 Assembled With Factory Installed Stainless Steel Bolts & Bedded With #8 Crushed Stone Or #8 Fractured Face Aggregate Bedding To 6" Above Top Of Valve.

REVISIONS		
Rev. No.	Description	Date

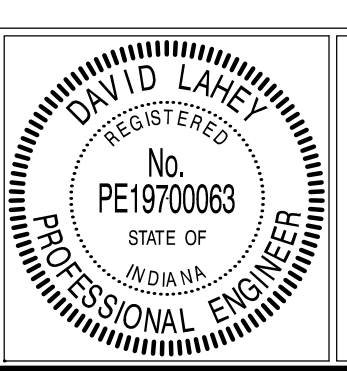

RECOMMENDED FOR APPROVAL	<i>David Laney</i>	DESIGN ENGINEER	01/01/2019	DATE
APPROVED	<i>James Smith</i>	TOWN ENGINEER	01/01/2019	DATE
APPROVED	<i>James Smith</i>	SUPERINTENDENT OF PUBLIC WORKS	11/1/2019	DATE

TOWN OF PLAINFIELD		<b>SHEET</b> 12 OF 25
WATER MAIN DETAILS & NOTES		

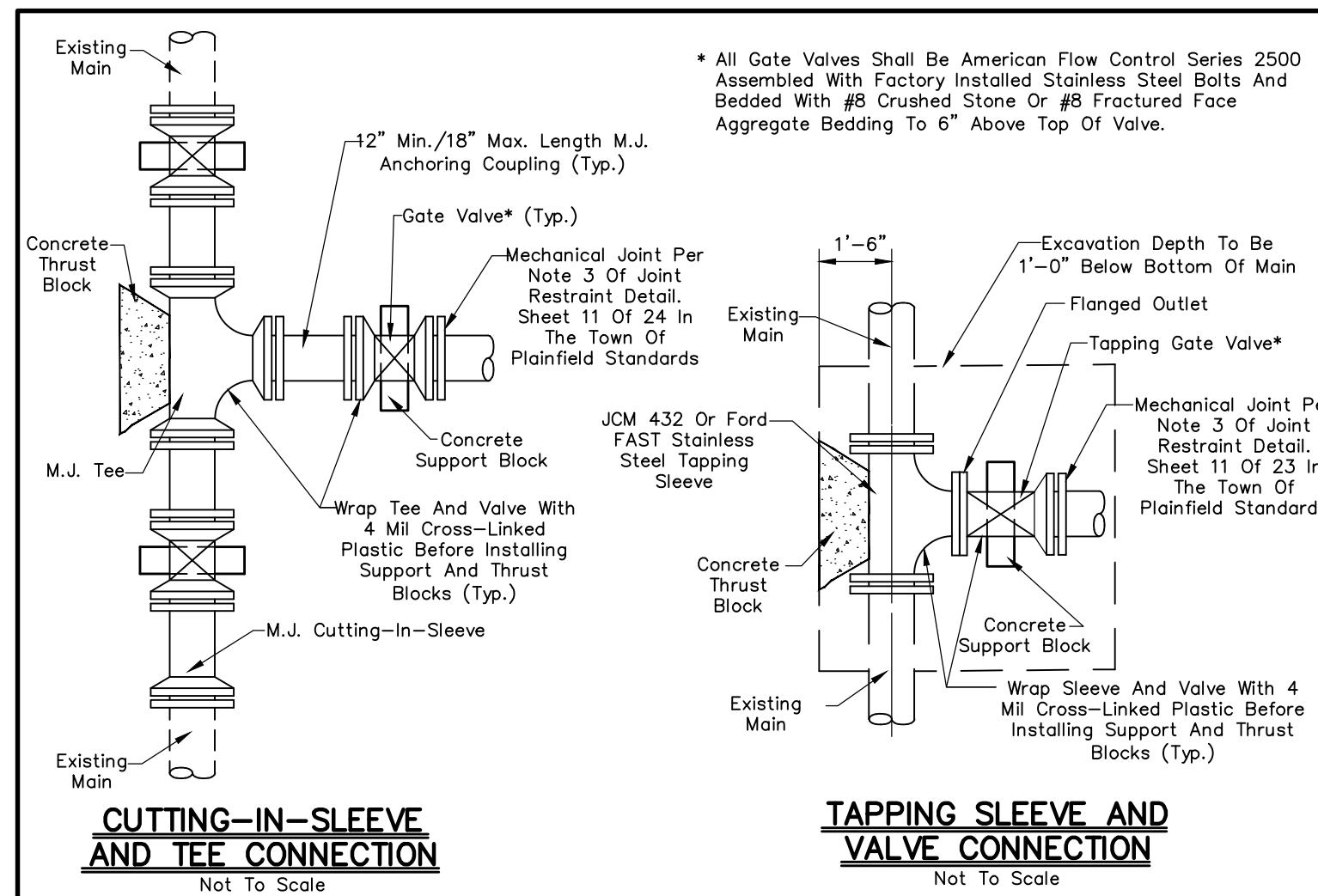

- WATER MAIN MATERIALS**
- All Pipe Provided For Use In The Town Of Plainfield Water System Shall Be Manufactured By American, Griffith, U.S. Pipe, Or As Approved By Plainfield DPW. All Fittings Provided For Use In The Town Of Plainfield Water System Shall Be Manufactured By Dow, Tyler, American, Or As Approved By Plainfield DPW.
  - Service Tubing To Customer Shall Be Copper Water Tube, Type K, Soft Temper For 3/4" Thru 2" For Underground Service, Conforming To ASTM B88, ASTM B251, And AWWA C600. Pipe Shall Be Marked With The Manufacturer's Name Or Trademark And Mark Indicative Of The Type Of Pipe. Outside Diameter Of The Pipe And Minimum Weight Per Foot Of Pipe Shall Not Be Less Than Listed In ASTM B251, Table II.

- WATER MAIN ABANDONMENT PROCEDURES**
- In Cases Where An Existing Main Line Is To Be Abandoned, The Abandonment Shall Include The Complete Removal Of The Tee And Replacement With Sleeve And Pipe As Required.
  - In Cases Where An Existing Service Line Is To Be Abandoned, The Abandonment Shall Include The Complete Removal Of The Service Line To Corporation Stop & Placement Of A Brass Cap At The Stop.

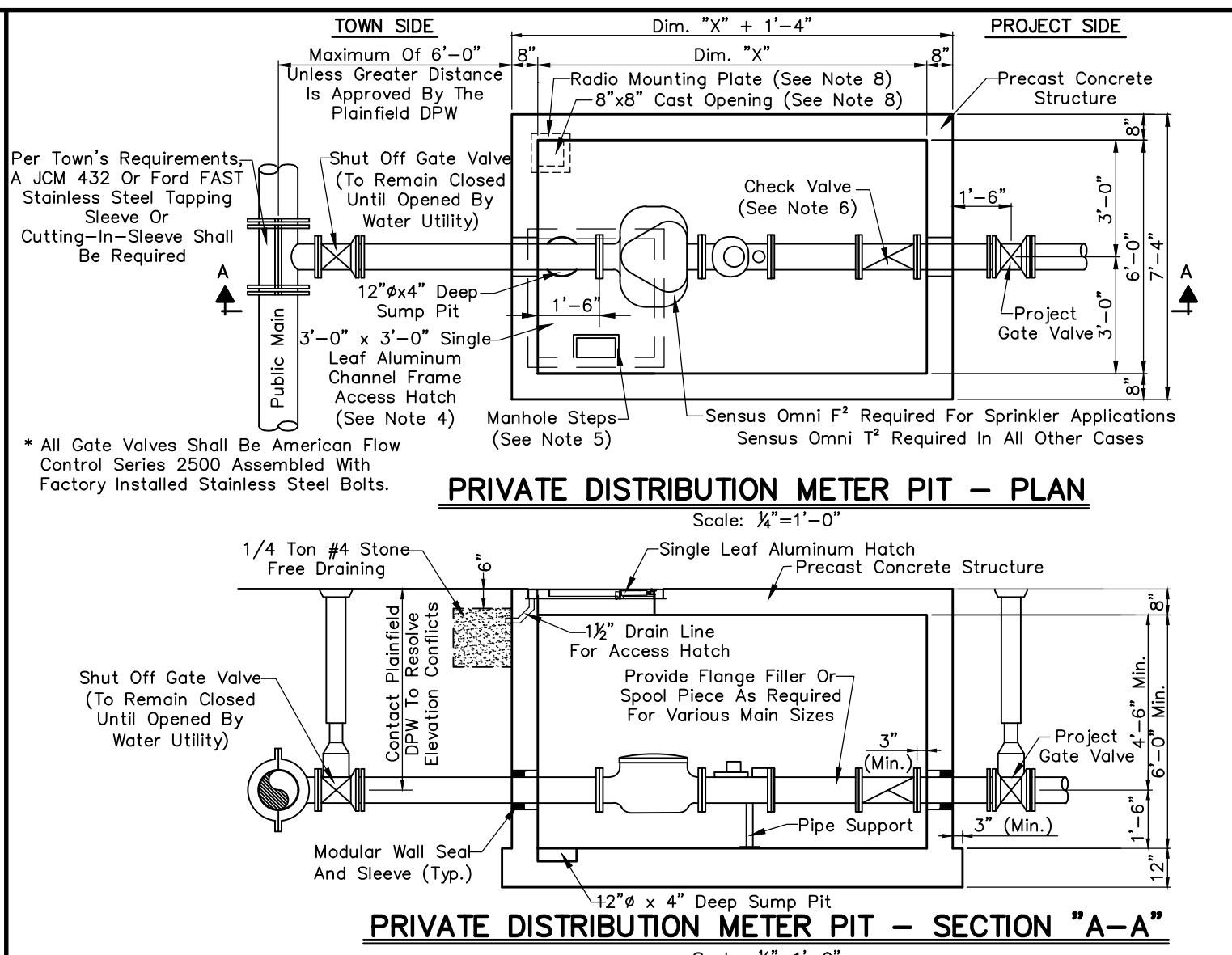

- Provide Minimum #4 Rebars On 12" Centers, Each Way In Top, Bottom, And All Sides.
- All Labor And Materials To Be Provided By The Developer.
- Piping, Valves, Double Detector Check Valve Assembly, And Meter Shall Be Same Size Throughout. Other Than Dim. "X", Meter Pit Dimensions Shall Be Maintained For 4", 6", And 8" Mains.
- Access Hatch Shall Be On Meter Side Of Pit And Shall Be Bilco Model J-4AL With Drain Coupling Or As Approved By Plainfield DPW.
- Manhole Steps Shall Be Neenah R-1981-J, E.J. No. 8512, M.A. Industries PS-1-PF, Or As Approved By Plainfield DPW.
- Check Valve Shall Be Bronze Seated And Shall Be Provided With Bolted Covers For Easy Access To The Discs. Valve Shall Be Outside Adjustable Weight And Level As Mueller A-2600-E-01, Kennedy/Crow 110BLK, Or As Approved By The Plainfield DPW.
- Piping In And Within 2 Feet Of Meter Pit Shall Be Class 53 Flanged Ductile Iron Pipe. Transition To Class 50 At A Mechanical Joint.
- Provide 1/4"x12"x12" Steel Plate, Paint Plate With 5 Mils DFT Tenmec 74-ANSI No. 61 Gray Over 3 Mils DFT Tenmec 90-97 Primer. Center Plate Over 8"x8" Opening. Secure Plate With Four 1/4"x304 S.S. Anchor Bolts, Nuts, And Washers.

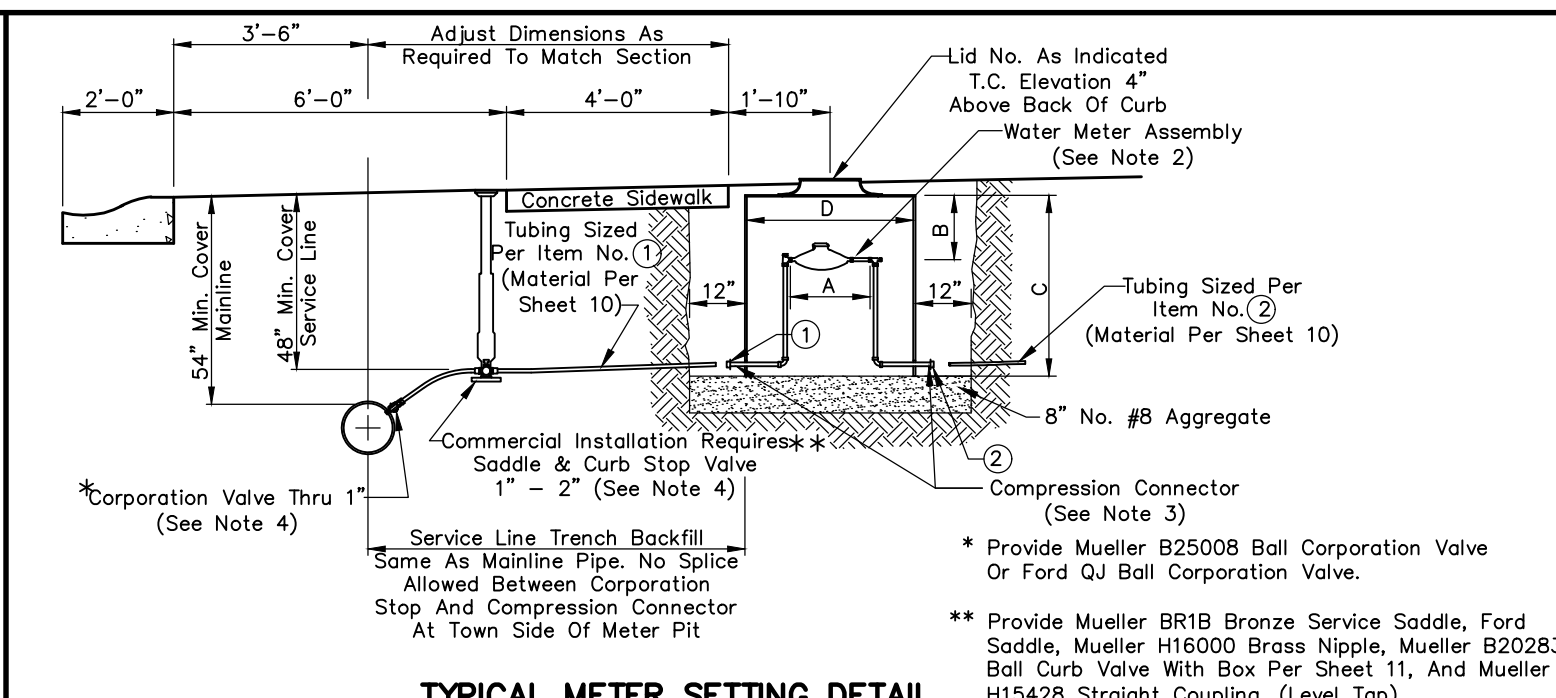

Mueller Part No.	RESIDENTIAL		COMMERCIAL		
	SINGLE 3/4"x3/4"	DUAL 3/4"x3/4"	SINGLE 1"x1"	SINGLE 1 1/2"x1 1/2"	SINGLE 2"x2"
Ford Part No.	203RS1848RBNN	203RD2148RBNN	330RS2148RBNN	500VB3648FBNN	550VB3648FBNN
PSBHH-244-18-48-NL	PSBHH-244-18-48-NL	PSBHH-244-20-48-NL	PSBHH-444-20-48-NL	PSBHH-644-36HB-48-NL	PSBHH-744-36HB-48-NL
Dim A	7.88"	7.88"	11.125"	13"	17"
Dim B	7"	7"	7"	16.5"	16.5"
Dim C	48"	48"	48"	48"	48"
Dim D	18"	21"/20"	21"/20"	36"	36"
Lid No.	Ford A32-T	Ford A3-T	Ford A3-T	Ford MC36-T	Ford MC36-T
①	3/4" Compression	1" Compression	1" Compression	2" Compression (See Note 4)	2" Compression
②	3/4" Compression	3/4" Compression	1" Compression	2" Compression (See Note 4)	2" Compression

- METER SETTING NOTES:**
- Residential Construction Requires The Use Of Dual Meter Installations Whenever Possible.
  - Water Meter Assembly Shall Consist Of Sensus 5/8" x 3/4" Meter, Yoke Valve On The Supply Side Of The Meter, And Ames LF2000B Double Check Assembly On The Customer Side Of The Meter. Meters For Residential Use Provided By Town, All Other Meters, Regardless Of Use, Provided By User.
  - The Contractor Shall Make All Tubing Connections Utilizing Mueller Or Ford Quick Compression Connectors.
  - Tubing May Be Used 1 1/2" Or 2" For Such 1 1/2" Meter. Provide Reducing Fittings As Required.
  - Residential Meters Require A Radio Read System. Commercial Meters And Radios Are Not Provided By The Town.
  - See Development Standards For Private Distribution Meter Pit And Procedures For Abandonment Of Service Lines.
  - Meter Lid Adjustment Shall Be Accomplished With Adjusting Rings Manufactured By Mueller Or Ford. The Maximum Adjustment Shall Be 4 Inches.

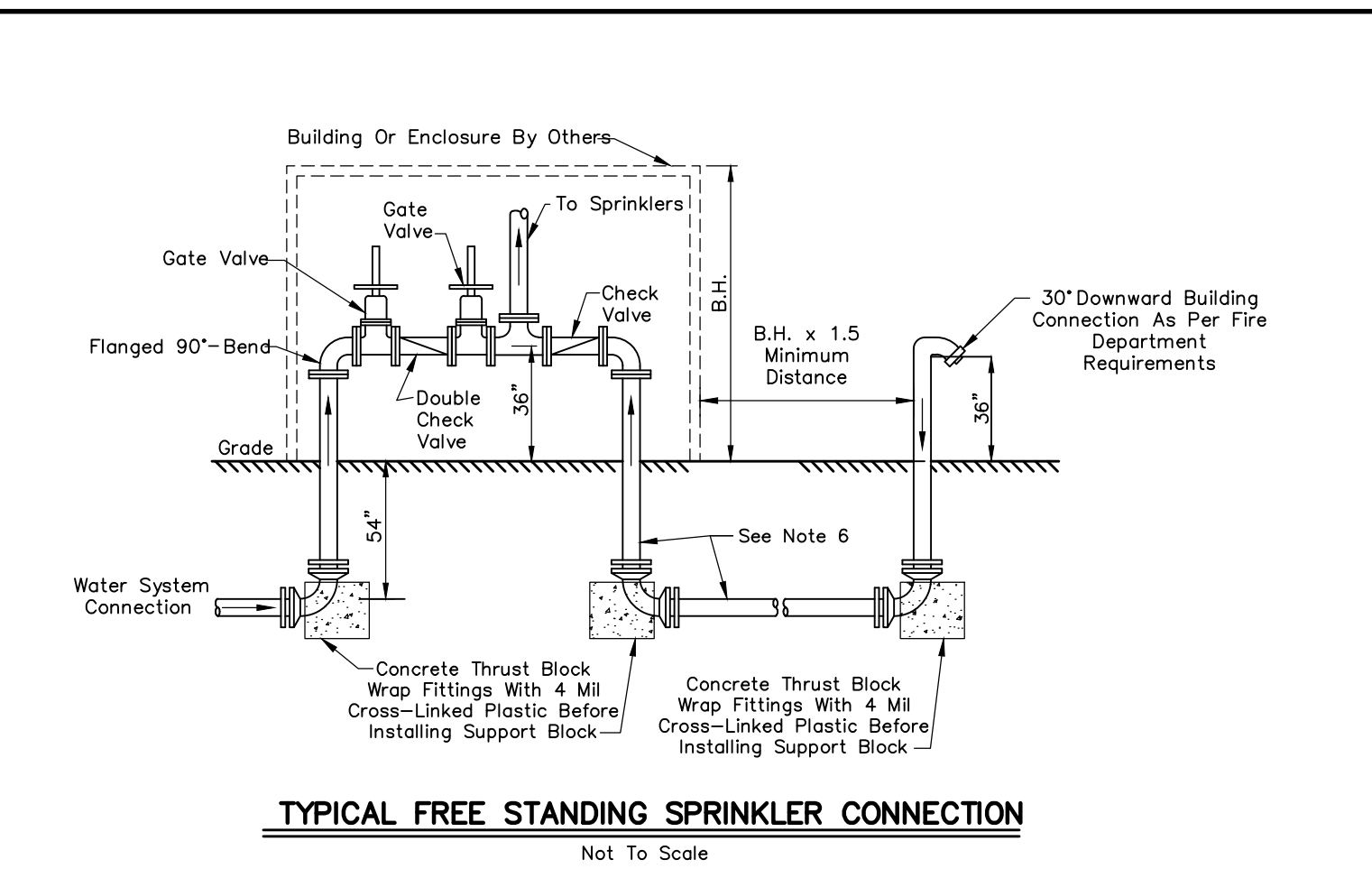

- NOTES:**
- The Connection Shall Be Within 150', As Measured On A Paved Roadway, Of A Fire Hydrant Supplied By The Public Water Main. The Connection And Hydrant Location Shall Be Such That From The Hydrant To A Fire Department Pumper, And From The Pumper To The Free Standing Sprinkler Connection, Access To Premises Will Not Be Blocked.
  - Underground Pipe Shall Be Designed And Constructed As Required For An Underground Fire Main Using NFPA 24. Design Shall Allow For Water To Drain After Use.
  - The Free Standing Sprinkler Connection Shall Be A 5" Threadless 45' Downward Connection.
  - The Free Standing Sprinkler Connection Shall Be Painted Red, And Labeled "SPRINKLER CONNECTION" OR "STANDPIPE CONNECTION" With The Address Served Displayed.
  - Where The Connection Is Subject To Vehicular Damage, The Connection Shall Be Protected. Protection Components Shall Not Be Closer Than 36" To The Connection And Shall Not Interfere With The Operation Of The Connection.
  - Fire Department Connection (FDC) Pipe Diameter Shall Not Be Reduced At Any Point In The FDC Line From The Point Of Connection At The Base Of The Sprinkler/Standpipe Riser (BOR) To The Point Of Attachment Of The 5 inch Storz Coupling.

**DEVELOPMENT STANDARD - DETAIL DS-W01**

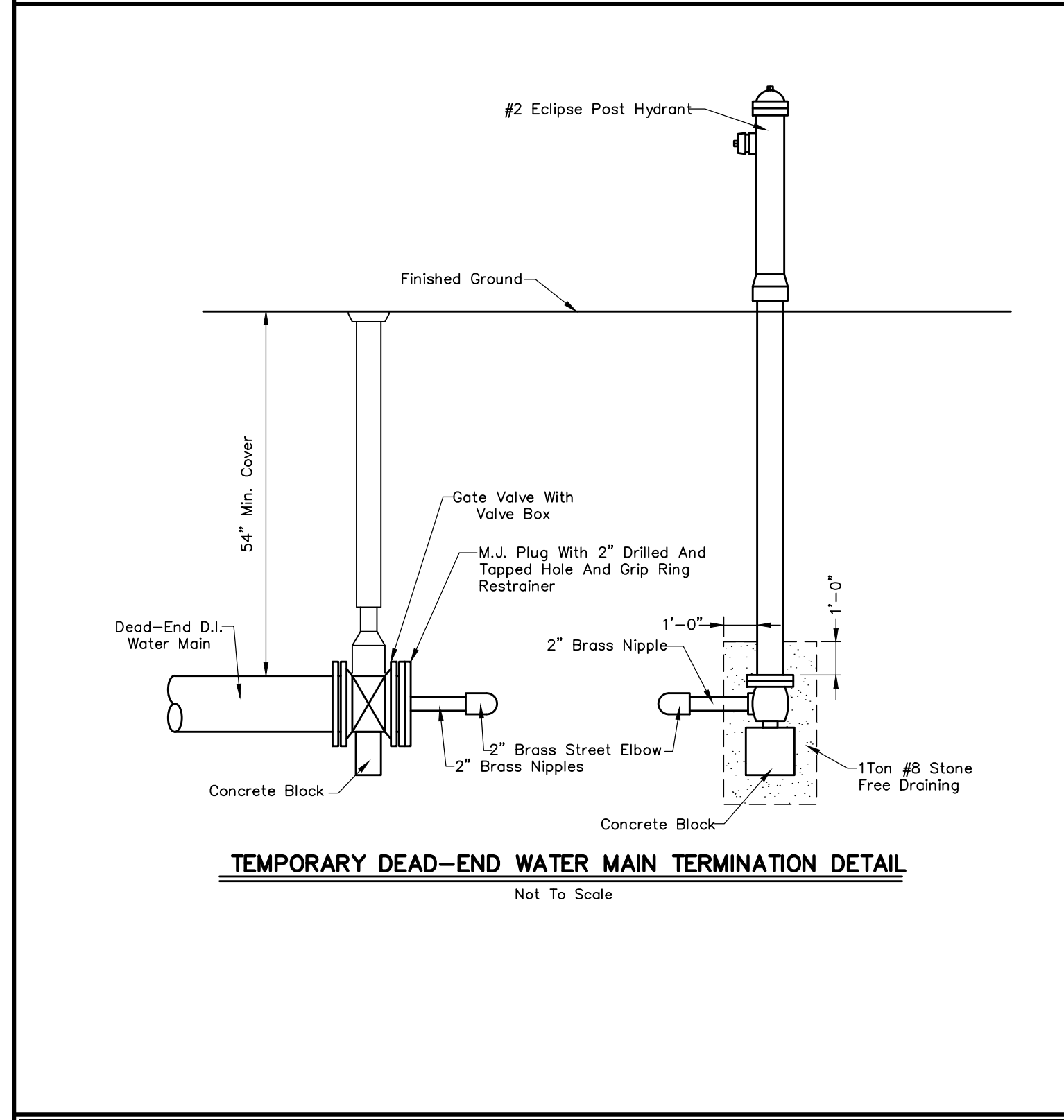

**DEVELOPMENT STANDARD - DETAIL DS-W05**

**DEVELOPMENT STANDARD - DETAIL DS-W02**

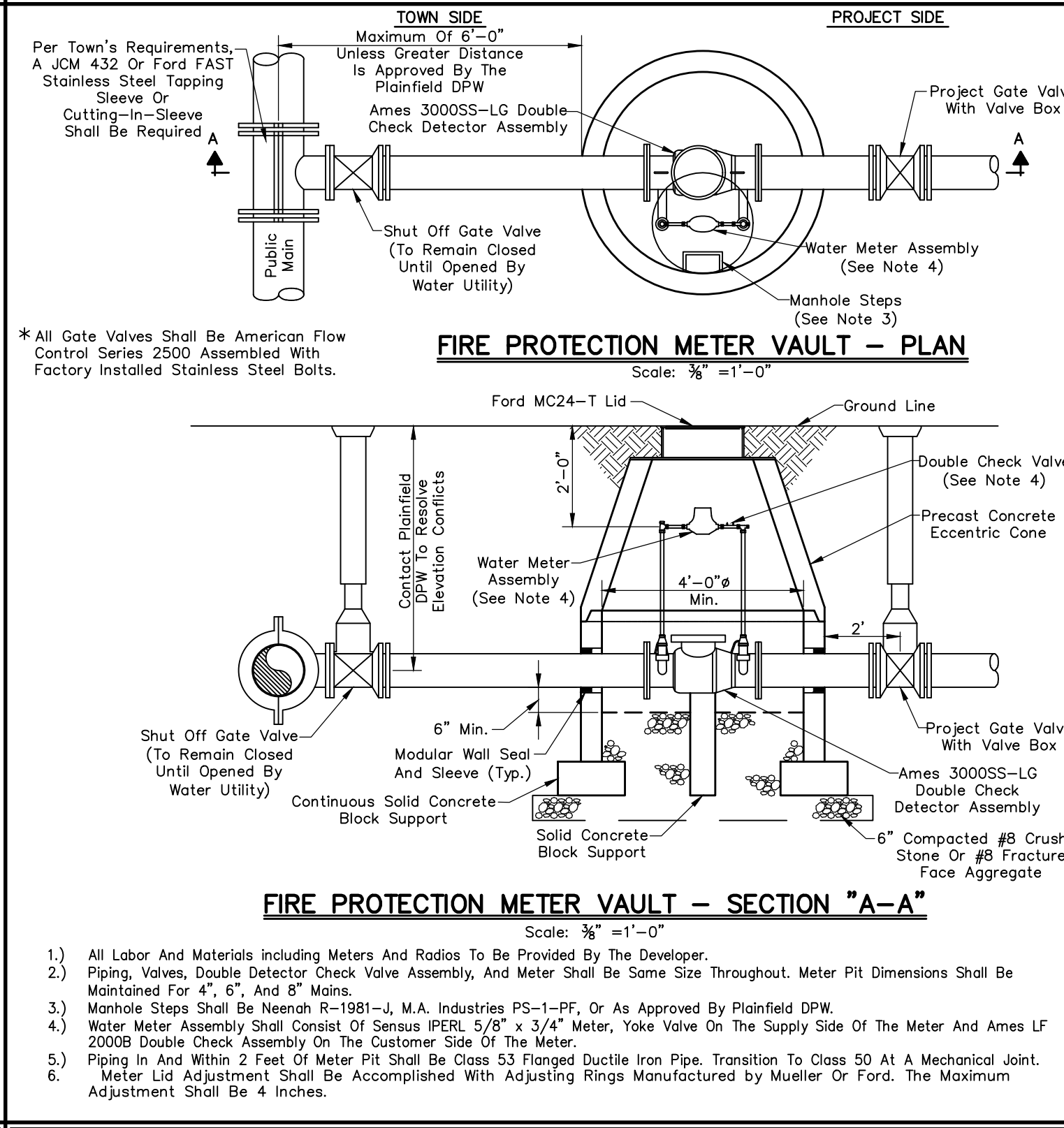

**DEVELOPMENT STANDARD - DETAIL DS-W06**

**DEVELOPMENT STANDARD - DETAIL DS-W03**

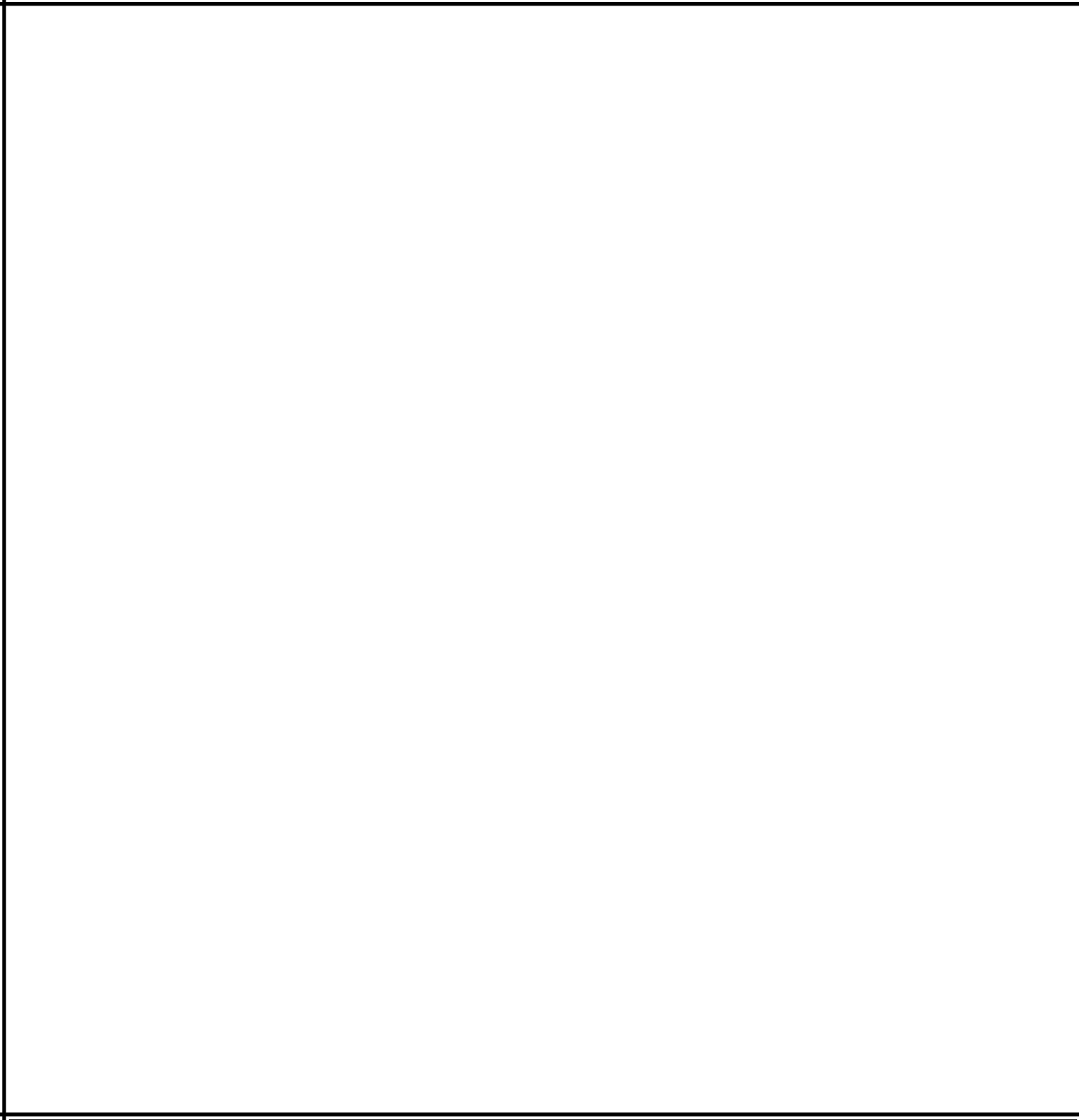

**DEVELOPMENT STANDARD - DETAIL DS-W04**

**REVISIONS**

Rev. No.	Description	Date

**DEVELOPMENT STANDARD - DETAIL DS-W04**



**DEVELOPMENT STANDARD - DETAIL DS-W06**

**TOWN OF PLAINFIELD**

**WATER (W) DEVELOPMENT STANDARDS**

**SHEET 13 OF 25**

**RECOMMENDED FOR APPROVAL**  
  
 DATE: 01/01/2019

**APPROVED**  
  
 DATE: 01/01/2019

**APPROVED**  
  
 DATE: 11/1/2019

**SANITARY SEWER REINFORCED CONCRETE PIPE**

- Reinforced Concrete Pipe For Use As Sanitary Sewers Shall Be Class III, IV, Or V As Specified By Design Engineer Per ASTM C76. Lift Holes Shall Not Be Permitted.
- Each Section Of Reinforced Concrete Pipe Shall Be Vacuum Tested By The Manufacturer Prior To Delivery To The Job Site. Only Pipe Sections Passing Vacuum Test Shall Be Marked As "Vacuum Tested". Vacuum Test Requirements Are As Follows:
  - Each Section Of Pipe Shall Tested By Bringing The Internal Pressure Within The Pipe To 3.5 PSIG Below Atmospheric Pressure And The Pressure Must Not Drop To Less Than 2.5 PSIG Below Atmospheric Pressure Within The Time Limitation As Determined By The Following:
 
$$T = \frac{0.022 D^2 L}{2}$$
 Where: T = Time In Seconds  
 D = Diameter Of Pipe In Inches  
 L = Length Of Pipe In Feet
  - Any Pipe Section Failing To Meet This Test Shall Not Be Permitted For Use As Sanitary Sewers In The Town Of Plainfield.
- Lateral Connections Shall Be Made With KOR-N-Tee, Inserta-Tee, Or Town Approved Equal.

- Each Pipe Section Shall Be Marked With The Date Of Manufacture, Size, And Class Of Pipe, Specification Designation, Manufacturer And Plant Identification.
- Pipe Shall Be Furnished With A Bell Or Groove On One End Of A Unit Of Pipe And A Spigot Or Tongue On The Adjacent End Of The Adjoining Pipe. All Joints Shall Have A Groove On The Spigot For Placement Of A Rubber "O"-Ring Or Profile Gasket In Accordance With ASTM C443. The Gasket Shall Be A Continuous Ring Which Fits Snugly Into The Annular Space Between The Overlapping Surfaces Of The Assembled Pipe Joint To Form A Flexible, Watertight Joint Under All Conditions Of Service.

**SANITARY SEWER POLYVINYL CHLORIDE (PVC) PIPE**

- PVC Pipe Diameters Of 4 Inches Through 15 Inches Shall Meet Or Exceed All Requirements Of ASTM D3034, And Shall Have A Minimum Cell Classification Of 12454. Reference Should Be Made To ASTM D1784 For A Summarization Of Cell Class Properties. PVC Pipe Diameters Greater Than 15 Inches Shall Meet Or Exceed All Requirements Of ASTM F679, And Shall Have A Minimum Cell Classification Of 12454.
- The Minimum Wall Thickness Of PVC Pipe 4 Inches Through 15 Inches In Diameter Shall Conform To SDR-35, Type PSM, As Specified In ASTM D3034 (See Note 5 For Fittings). The Minimum Wall Thickness For P.V.C. Pipe Greater Than 15 Inches Shall Conform To PS 46 As Specified In ASTM F679. P.V.C. Pipe Shall Have A Minimum Pipe Stiffness Of 46 Pounds Per Square Inch For Each Diameter When Measured At Five Percent Deflection And Tested In Accordance With ASTM D2412.
- PVC Open Profile Or Closed Profile Sewer Pipe Shall Meet Or Exceed All Requirements Of ASTM F794 Or ASTM F949, And Shall Have A Minimum Cell Classification Of 12454 And A Minimum Uniform Pipe Stiffness Of 50 Pounds Per Square Inch For Each Diameter When Measured At Five Percent Deflection And Tested In Accordance With ASTM D2412 (See Note 5 For Fittings).
- Pipe Joints Shall Have A Bell Wall, Gasket Groove, And Spigot Which Is Integral With The Pipe. The Assembly Of Joints Shall Be In Accordance With Pipe Manufacturer's Recommendations And ASTM D3212. Solvent Cement Joints Shall Not Be Allowed For Mainline Pipe.
- Pipe Fittings Shall Be SDR-26 Manufactured Fittings Made Of PVC Plastic Having A Cell Classification Of 12454 As Defined In ASTM D1784. Saddle Connections Shall Not Be Allowed For New Construction. Lateral Connections Shall Occur At SDR-26 Tee-Wyes.
- Each Pipe Section Shall Be Marked With The Name Of Manufacturer, Trademark Or Tradename, Nominal Pipe Size, Production/Extrusion Code, Material And Cell Classification, And ASTM Number.
- Installation Shall Be In Accordance With Recommended Practice ASTM D2321.

**SANITARY SEWER LATERAL PIPE AND FITTINGS**

- See Development Standards DS-S01, DS-S02, For Sanitary Sewer Lateral Requirements.

**SANITARY SEWER GENERAL NOTES**

- Sanitary Sewer Pipe Of Other Material Or Material Not Meeting These Specifications Shall Require The Prior Written Approval Of Plainfield DPW.
- The Contractor Shall Submit Information To The Town Engineer Showing Conformance With These Specifications Upon Request.
- As-Built Drawings Shall Be Submitted To Plainfield DPW.

**SANITARY SEWER DEFLECTION TESTING AND TELEVISION**

- Deflection Testing Is Required For All Mainline Flexible Pipe And Plainfield DPW Shall Be Given 24 Hour Written Notice Of Deflection Testing. An Allowable Deflection Of 5 Percent Inside Pipe Diameter Will Be Acceptable After All Backfilling Has Been In Place For 30 Days. A Nine Point "Go-No-Go" Mandrel Shall Be Used For The Deflection Test. A Proving Ring Shall Be Provided For Each Mandrel. All Pipe Exceeding The Allowable Deflection Shall Be Televised To Determine The Extent Of Replacement Or Rerouting Required. The Reworked Section Shall Be Retested 30 Days After Completion. Contractor Shall Bear All Testing Costs. The "Go-No-Go" Mandrel Shall Be Manually Pulled Without The Use Of Mechanical Devices.
- Following Air And Mandrel Testing, Televising Is Required. Plainfield DPW Shall Be Given 24 Hour Written Notice Of Televising. A Camera Equipped With Remote Control Devices To Adjust Light Intensity And 1,000 Linear Feet Of Sewer Cable Shall Be Provided. The Camera Shall Transmit A Continuous Image To The Television Monitor As It Is Being Pulled Through Pipe. The Image Shall Be Clear Enough To Enable The Town Of Plainfield Representative And Others Viewing The Monitor To Easily Evaluate The Interior Condition Of The Pipe. The Camera Shall Stamp The DVD With Manhole Number, Lateral Distance From Manhole, Linear Footage And Project Number, And An Audio Voice-Over Shall Be Made During The Inspection Identifying Problems. Contractor Shall Bear All Televising Costs.
- The Pipe Shall Be Thoroughly Cleaned Before Installing Camera And Commencing Televising.
- If Any Pipe And/Or Joint Is Found To Be Leaking, Regardless Of The Results Leakage Testing, In The Sole Judgement Of The Town, The Contractor Shall Repair That Portion Of The Work To The Satisfaction And Approval Of The Town Of Plainfield.

**SANITARY SEWER LEAKAGE TESTING**

- The Town Of Plainfield Shall Be Given 24 Hour Written Notice Of The Required Leakage Testing Procedure To Be Performed By The Contractor. Low Pressure Air Shall Be Slowly Introduced Into The Sealed Line Until The Internal Air Pressure Reaches 4 PSIG Plus The Groundwater Head Divided By 2.31 (Maximum Test Pressure Is 9 PSIG).
- At A Stable Internal Air Pressure Within 0.5 PSIG Of The Initial Internal Air Pressure, Timing Shall Commence With A Stopwatch Or Similar Device Of 99.8 Percent Accuracy. Timing Shall End When The Internal Air Pressure Drops 1 PSIG Below The Stable Internal Air Pressure.
- The Line Shall Be Accepted If The Time Shown In Table 1 For The Designated Pipe Size And Length Elapses Before The Air Pressure Drops 1 PSIG Below The Stable Internal Air Pressure At Which Time The Test Can Be Discontinued For The Accepted Line.

**TABLE 1**

**SPECIFICATION TIME REQUIRED FOR A 1.0 PSIG PRESSURE DROP FOR SIZE AND LENGTH OF PIPE INDICATED FOR Q=0.0015**

1 Pipe Diameter (In.)	2 Minimum Time (Min:Sec)	3 Length For Minimum Time (Ft.)	4 Time For Longer Length (Sec.)	Specification Time For Length (L) Shown (Min.:Sec.)								
				100 Ft.	150 Ft.	200 Ft.	250 Ft.	300 Ft.	350 Ft.	400 Ft.	450 Ft.	
4	3:46	597	.380L	3:46	3:46	3:46	3:46	3:46	3:46	3:46	3:46	
6	5:40	398	.854L	5:40	5:40	5:40	5:40	5:40	5:40	5:42	6:24	
8	7:34	298	1.520L	7:34	7:34	7:34	7:34	7:36	8:52	10:08	11:24	
10	9:26	239	2.374L	9:26	9:26	9:26	9:53	11:52	13:51	15:49	17:48	
12	11:20	199	3.418L	11:20	11:20	11:20	11:24	14:15	17:05	19:56	22:47	
15	14:10	159	5.342L	14:10	14:10	17:48	22:15	26:42	31:09	35:36	40:04	
18	17:00	133	7.692L	17:00	19:13	25:38	32:03	38:27	44:52	51:16	57:41	
21	19:50	114	10.470L	19:50	26:10	34:54	43:37	52:21	61:00	69:48	78:31	
24	22:40	99	13.674L	22:47	34:11	45:34	56:58	68:22	79:46	91:10	102:33	
27	25:30	88	17.306L	28:51	43:16	57:41	72:07	86:32	100:57	115:22	129:48	
30	28:20	80	21.366L	35:37	53:25	71:13	89:02	106:50	124:38	142:26	160:15	
33	31:10	72	25.852L	43:05	64:38	86:10	107:43	129:16	150:43	172:21	193:53	
36	34:00	66	30.768L	51:17	76:55	102:34	128:12	153:50	179:29	205:07	230:46	

**NOTE:**  
For More Efficient Testing Of Long Test Sections And/Or Sections Of Larger Diameter Pipes, A Timed Pressure Drop Of 0.5 PSIG May Be Used In Lieu Of The 1.0 PSIG Timed Pressure Drop. If A 0.5 PSIG Pressure Drop Is Used, The Required Test Time Shall Be Exactly Half As Long As Those Shown Above.

**SANITARY FORCE MAIN PRESSURE AND LEAKAGE TESTING**

- The Town Of Plainfield Shall Be Given 24 Hour Written Notice Of The Required Pressure And Leakage Test To Be Performed By The Contractor. The Pressure And Leakage Test Shall Be Performed In Accordance With The Basic Provisions Of AWWA C600. All Force Mains Shall Be Given A Hydrostatic Test Of At Least 1.5 Times The Shutoff Head Of The Connected Pumps Or 150 PSI, Whichever Is Lesser. Test Pressure Shall Not Exceed Pipe Restraint Design Pressures Or Rated Pressure Of The Valves. Loss Of Water Pressure During Test Shall Not Exceed 5 PSI In A 2 Hour Test Period.
- Valves Shall Not Be Operated In Either Direction At Differential Pressures Exceeding The Rated Valve Working Pressure.
- The Pressure And Leakage Test Shall Be Performed Following The General Form Of The Following:
  - Record Time And Line Pressure Prior To Start Of Test.
  - Pump Water Into New Force Main Until Pressure Reaches At Least 1.5 Times The Shutoff Head Of The Connected Pumps Or 150 PSIG, Stop Pumping And Record Time And Line Pressure.
  - Contractor Shall Remain At Site For One Hour. The Test Shall Be Voided If Any Adjustments Are Made To The Force Main, Test Equipment, Or Appurtenances. Tightening Of Fittings On Test Equipment Is Allowed. Following The One Hour Period, Record Time And Line Pressure.
  - Pump Water Into New Force Main From A Calibrated Container Of Water Until Pressure Reaches 150 PSIG, Stop Pumping When Pressure Reaches 150 PSIG, Record Time, Line Pressure, And Amount Of Water Pumped To The Nearest 1/100 Gallon. The Calibrated Container Shall Have Markings At 1/10 Gallon Increments.
  - Repeat Steps C And D One Additional Time.
- A Test Section Of Force Main Is Considered Satisfactory If It Meets The Following:

Main Size (Inches)	Allowable Leakage (Gal./Hr./1000 Ft.)
4	0.33
6	0.50
8	0.66
10	0.83
12	0.99

- If The Leakage From A Test Section Is Greater Than Permitted Under These Specifications, The Contractor Shall Locate And Repair The Defective Joints, Mains, And Appurtenances. The Pressure And Leakage Test Shall Then Be Repeated Until Satisfactory Results Are Obtained. All Labor And Materials Required To Meet The Requirements Of The Pressure And Leakage Test Shall Be At The Expense Of The Contractor.

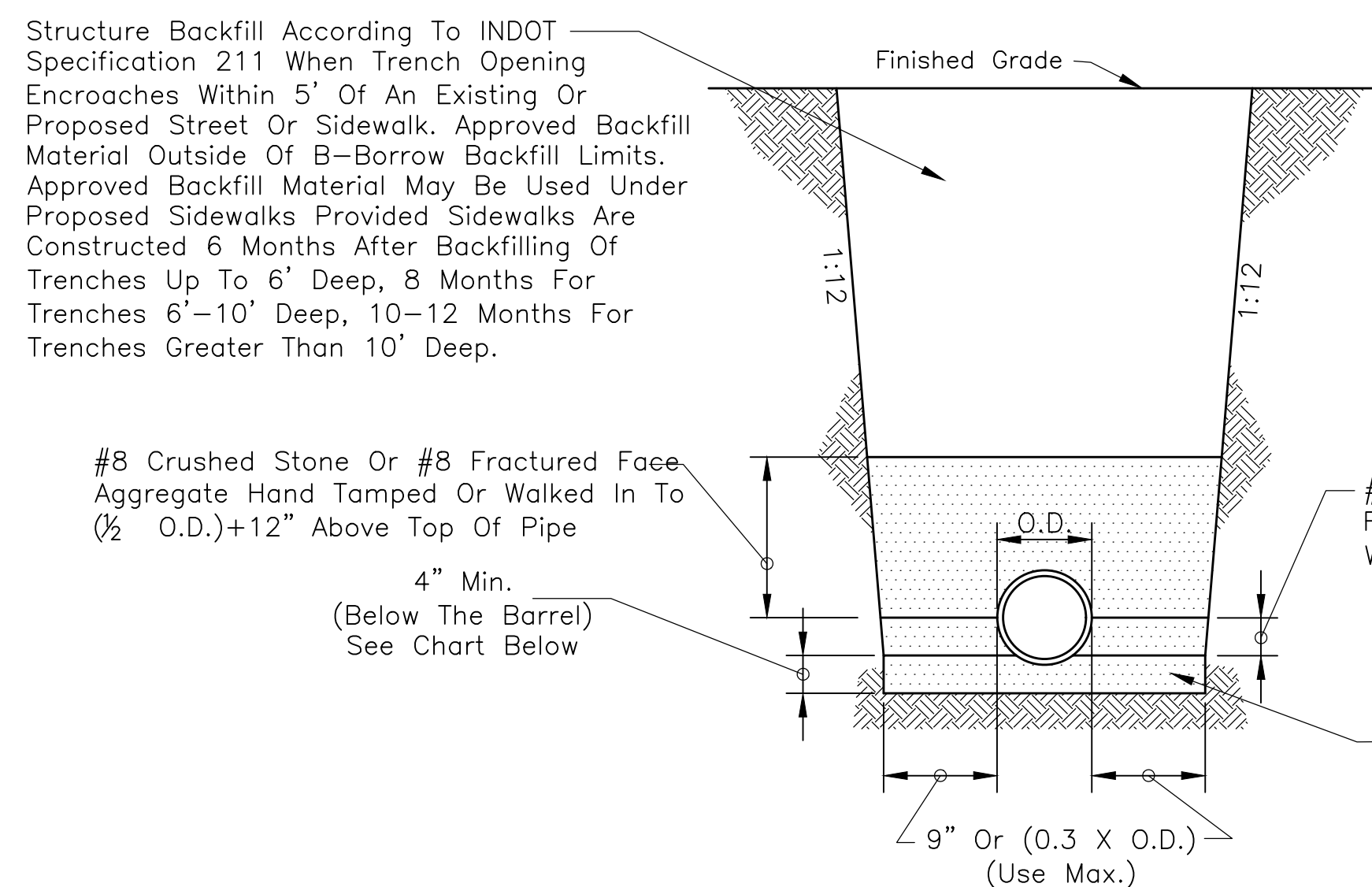

Pipe Size	8" To 15"	18" And Over
Bedding Below The Pipe Barrel	O.D./4 Min.=4"	O.D./4 Min.=8"

\*See Development Standard DS-S01 For Lateral Pipe Bedding\*

**PVC PIPE BEDDING DETAIL**

Scale: None

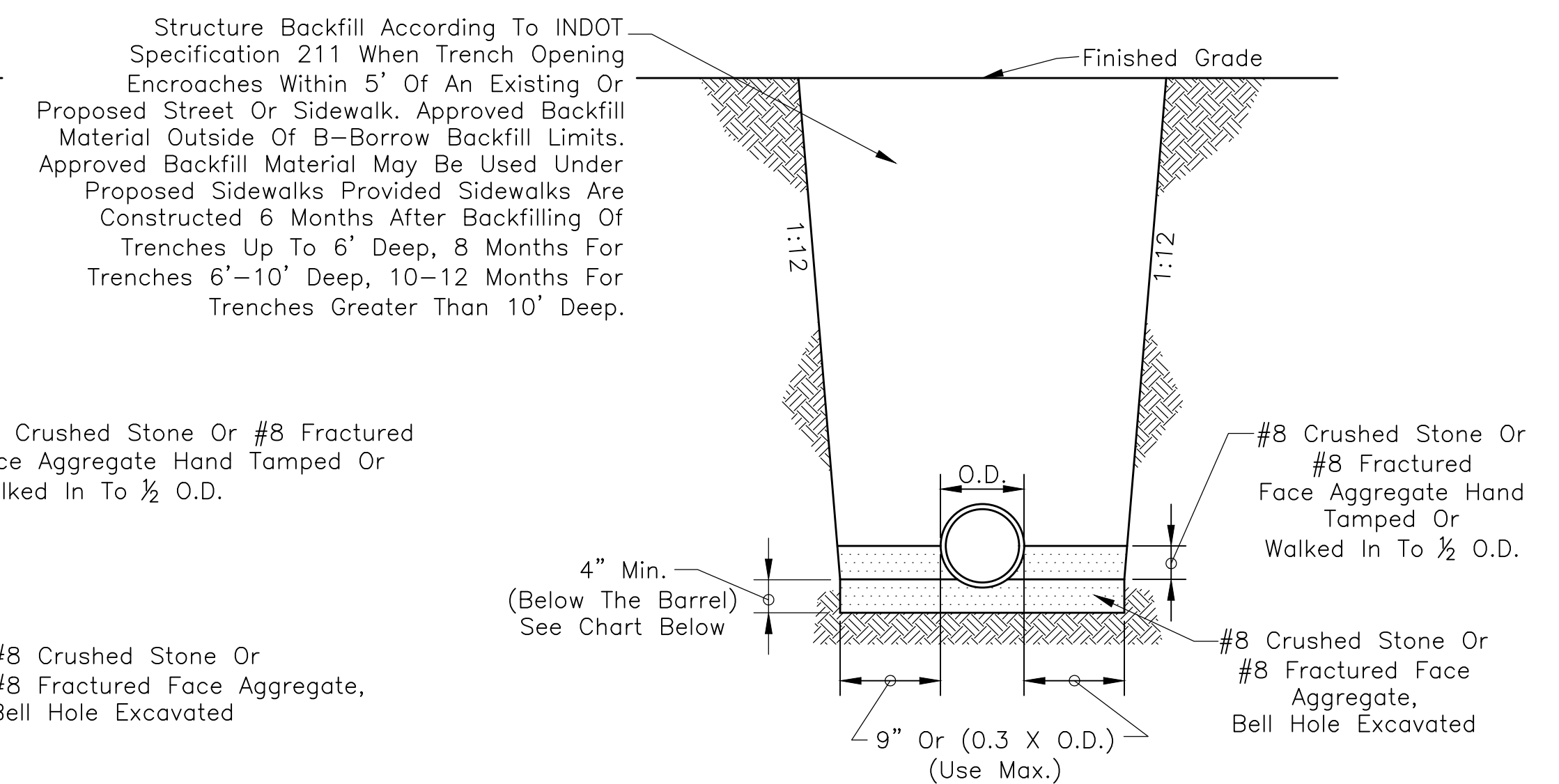

Pipe Size	8" To 15"	18" And Over
Bedding Below The Pipe Barrel	O.D./4 Min.=4"	O.D./4 Min.=8"

**RCP BEDDING DETAIL**

Scale: None

REVISIONS		
Rev. No.	Description	Date

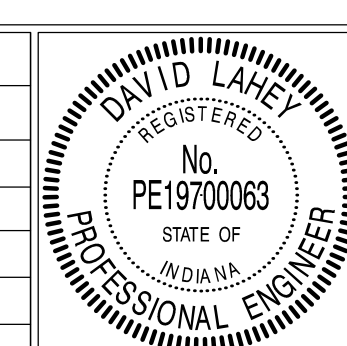

RECOMMENDED FOR APPROVAL: *David Lacey* DESIGN ENGINEER DATE: 01/01/2019  
 APPROVED: *James Smith* TOWN ENGINEER DATE: 01/01/2019  
 APPROVED: *James Smith* SUPERINTENDENT OF PUBLIC WORKS DATE: 11/1/2019

TOWN OF PLAINFIELD  
 SANITARY SEWER  
 BEDDING DETAILS AND NOTES

SHEET  
 14  
 OF  
 25

**MANHOLES**

- 1.) Precast Concrete Manholes Shall Conform To ASTM C478, With Rubber Type Gaskets Equal To ASTM C443. Monolithic Cast In Place Manholes Shall Only Be Used With The Prior Written Approval Of The Town. The Base And First Riser Section Of The Precast Concrete Manhole Shall Be Integrally Cast As One Unit. Precast Concrete Cones Shall Be Of The Eccentric Cone Type. No "See Through" Lift Holes Shall Be Allowed On Precast Concrete Manholes 48 Inches In Diameter Or Less. In Addition To The Rubber Type Gaskets, All Joints Shall Receive A 1/2 Inch Diameter Non-Asphaltic Mastic (Kent-Seal Or As Approved By Plainfield DPW) Conforming To AASHTO M-198 And Federal Specifications SS-S-210A. Sewer Connection To Manhole Shall Be KOR-N-SEAL, A-LOK, Press-Seal, Or As Approved By Plainfield DPW.
- 2.) Where One Solid Riser Or Barrel Section Cannot Be Used, Final Adjustment In Elevation Of The Frame And Cover Shall Be Accomplished By The Use Of A 4 Inch Minimum Thickness Adjusting Ring As Detailed Herein To A Maximum Combined Thickness Of 12 Inches. Brick Or Block Shall NOT Be Used In The Construction Of A Manhole Or To Adjust The Elevation Of The Frame And Cover.
- 3.) Manhole Steps Shall Be Neenah No. R-1981-J, M.A. Industries No. PS 1-PF, Or As Approved By Plainfield DPW.
- 4.) Manhole Frame And Cover Shall Be As Per Development Standards Detail DS-S06 Or Town Approved Equal.
- 5.) The Lowest Elevation To Receive Gravity Sanitary Service Must Be One Foot Above The Top Of Manhole Casting. Elevation Of Either The First Upstream Or Downstream Manhole On The Public Sewer To Which Connection Is To Be Made. Those Portions Of The Building Not Meeting The Stated Gravity Sanitary Service Requirement Shall Be Provided With A Grinder Pump System Or Town Approved Equal Discharging To The Gravity Building Connection Outside Of The Public Right-Of-Way.
- 6.) Infiltration Barrier Shall Be 60 Mils Minimum EPDM Sealed With A 2 Inch Mastic Strip To Cone (Manhole) And To Top Of Casting Lip And Shall Be Infi-Shield Or Town Approved Equal.
- 7.) Plainfield DPW May Approve Alternate Drop Connection If There Are Special Circumstances.
- 8.) Lateral Connection To A Manhole Is Prohibited.
- 9.) 10% Of All Sanitary Manholes Shall Be Vacuum Tested With Castings Per ASTM C1244 Following Full Installation. All Sanitary Manhole Sections Shall Be Vacuum Tested In The Shop Prior To Shipment. Dewatering Shall Continue In Order To Prevent Hydrostatic Pressures From Affecting The Test.

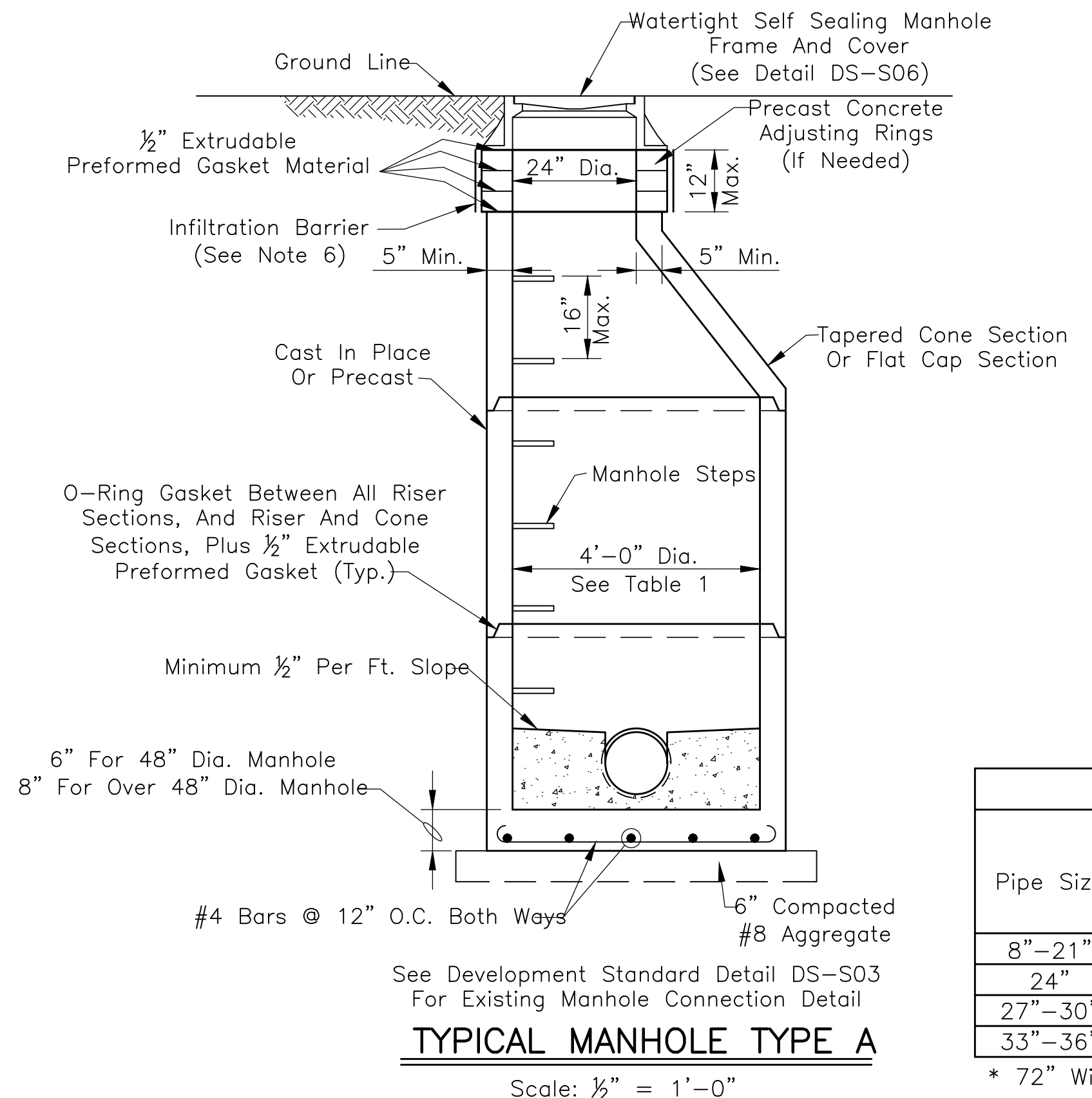

**TABLE 1**  
Minimum Manhole Diameter

Pipe Size	Minimum Manhole Diameter	
	Pipe Entering/ Pipe Exiting At 0° To 45° Bend	Pipe Entering/ Pipe Exiting At 45° To 90° Bend
8"-21"	48"	48"
24"	48"	60"
27"-30"	60"	60"
33"-36"	60"*	72"

\* 72" With A-Lock Connector

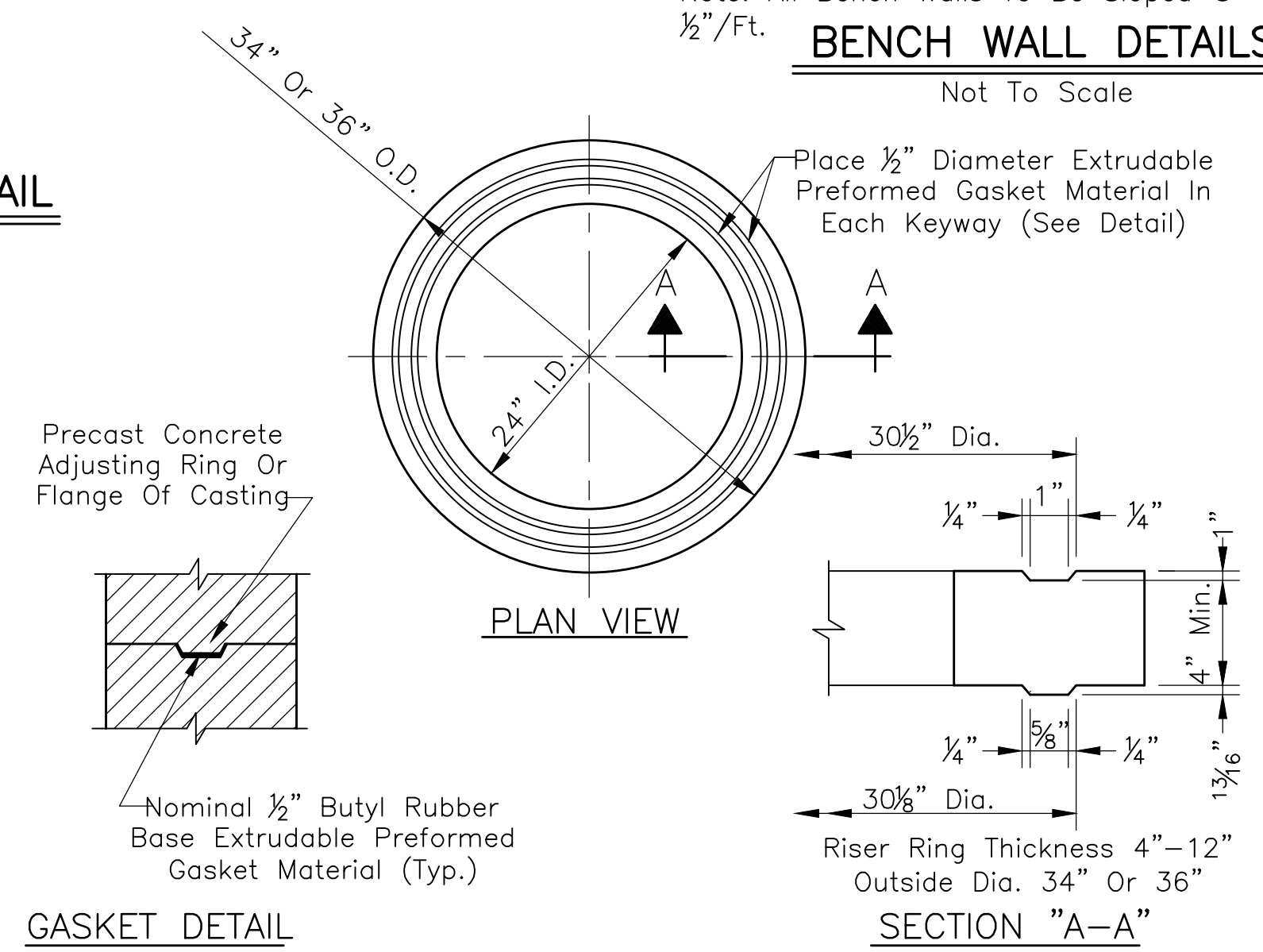
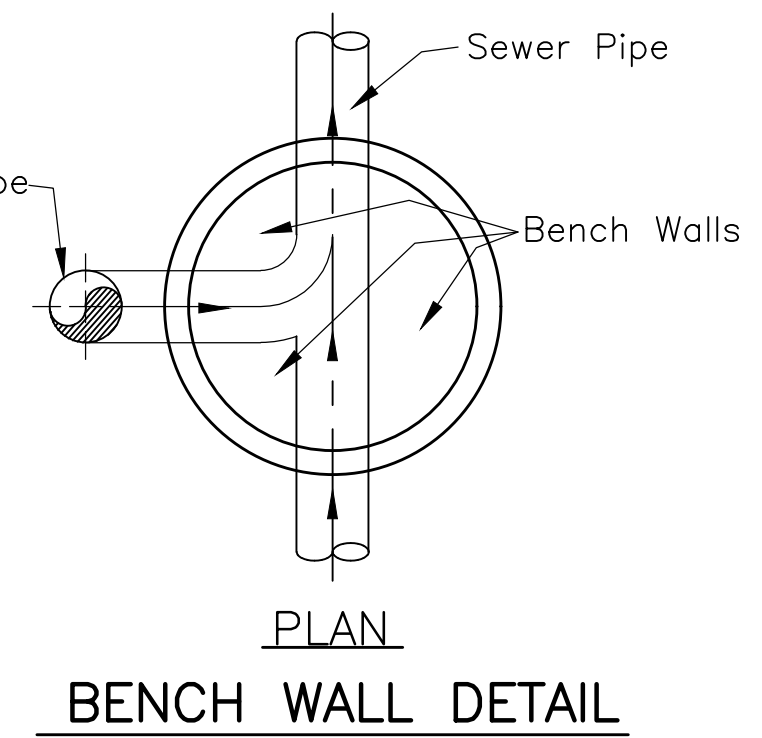
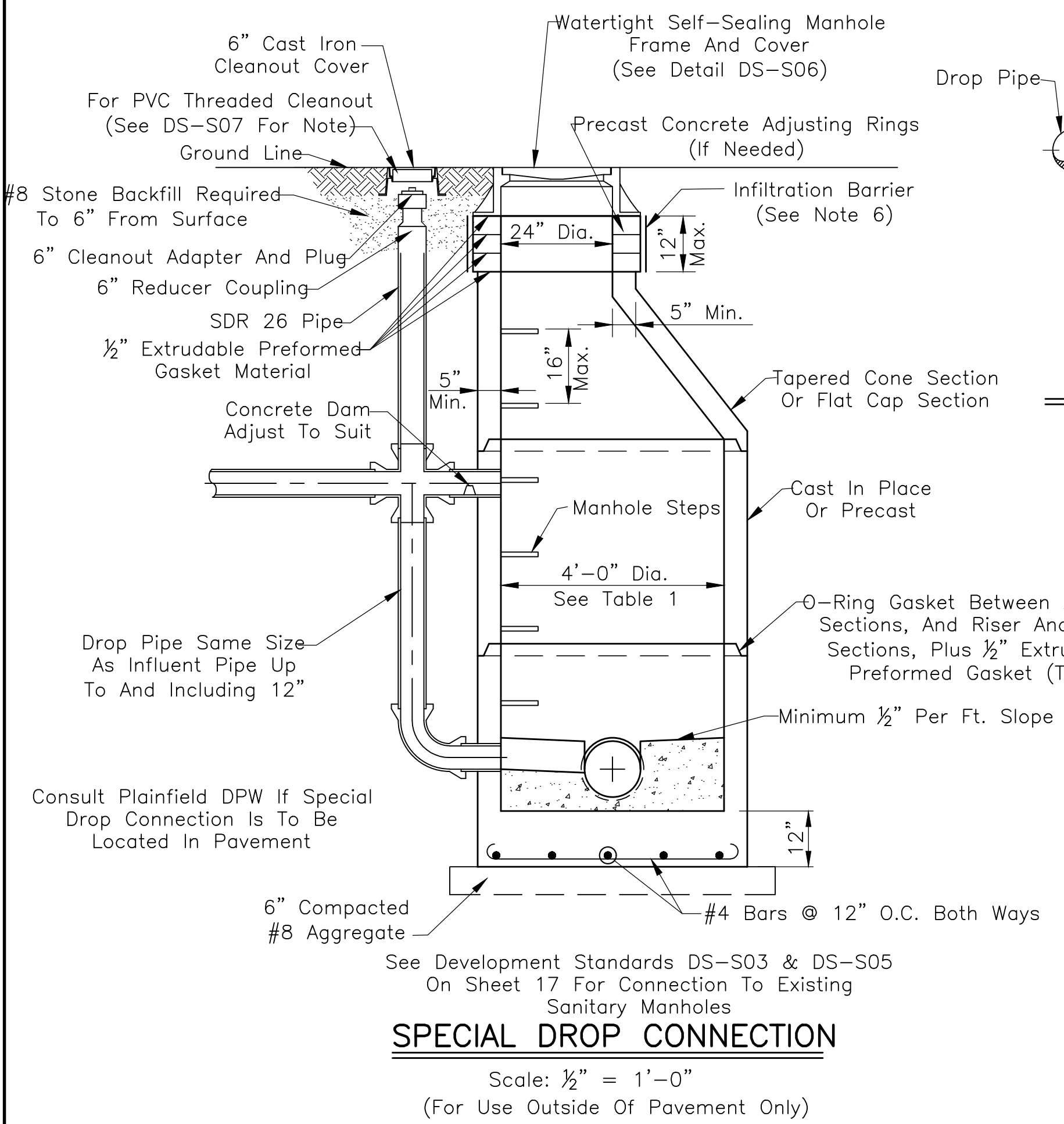
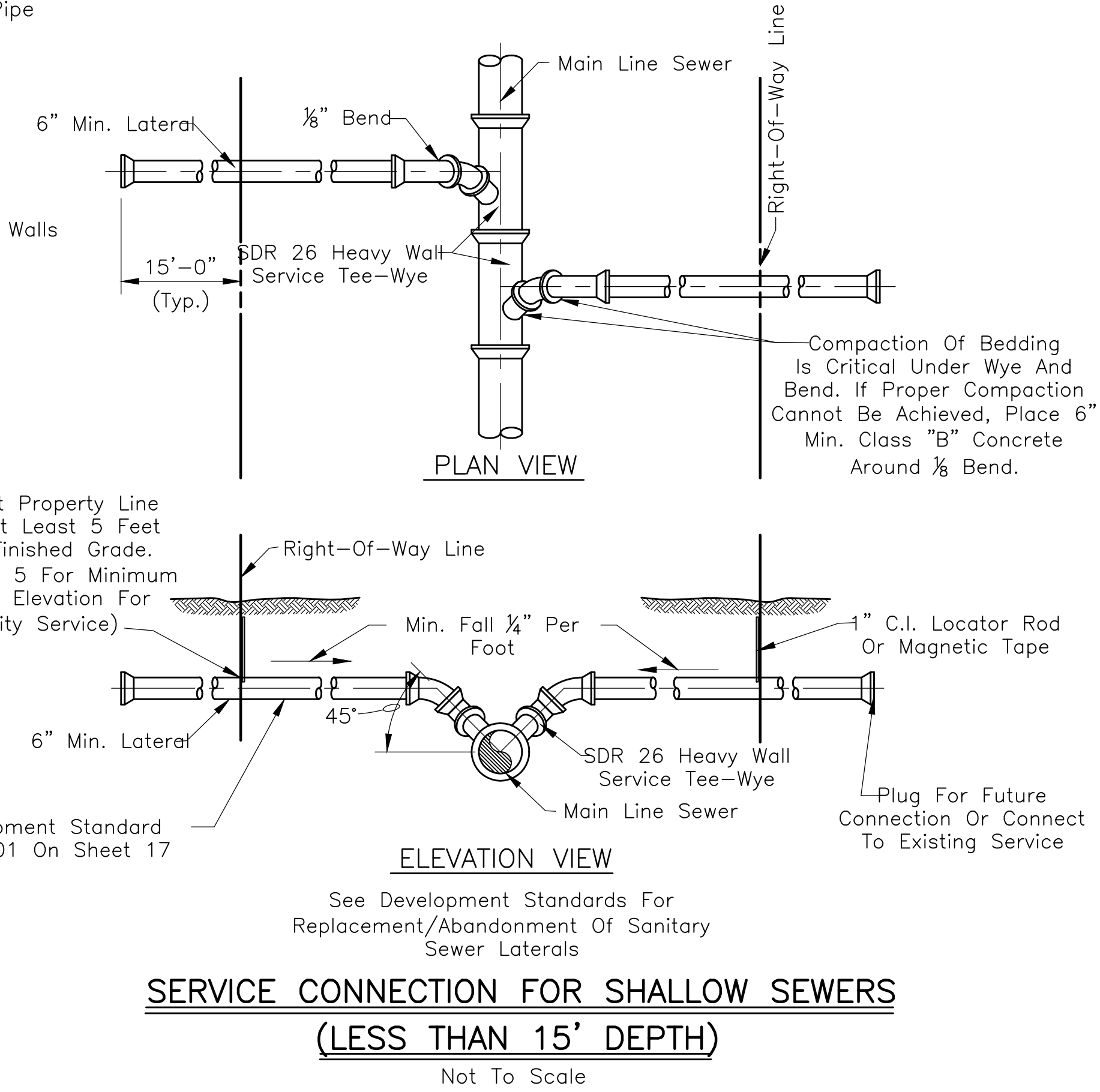
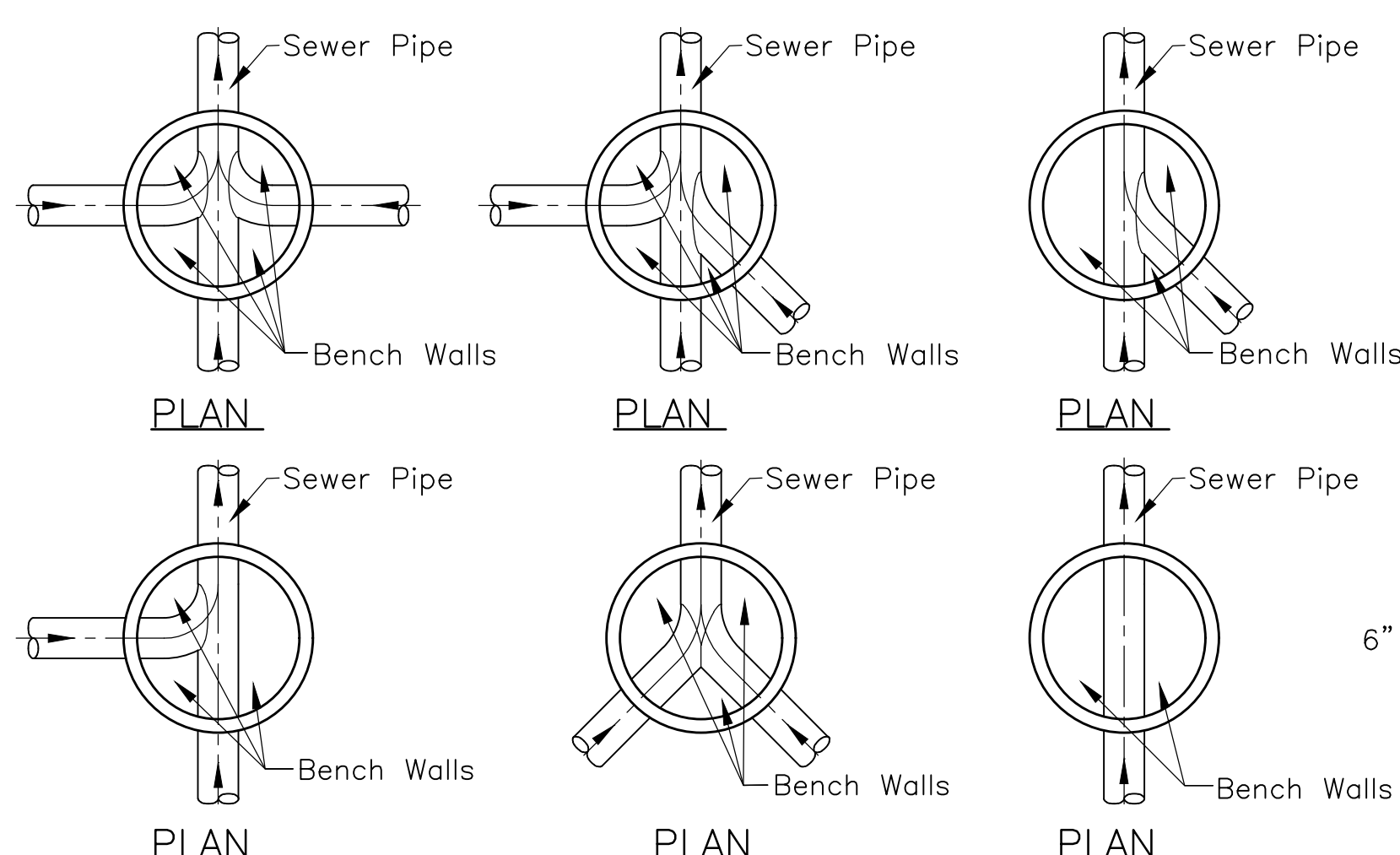
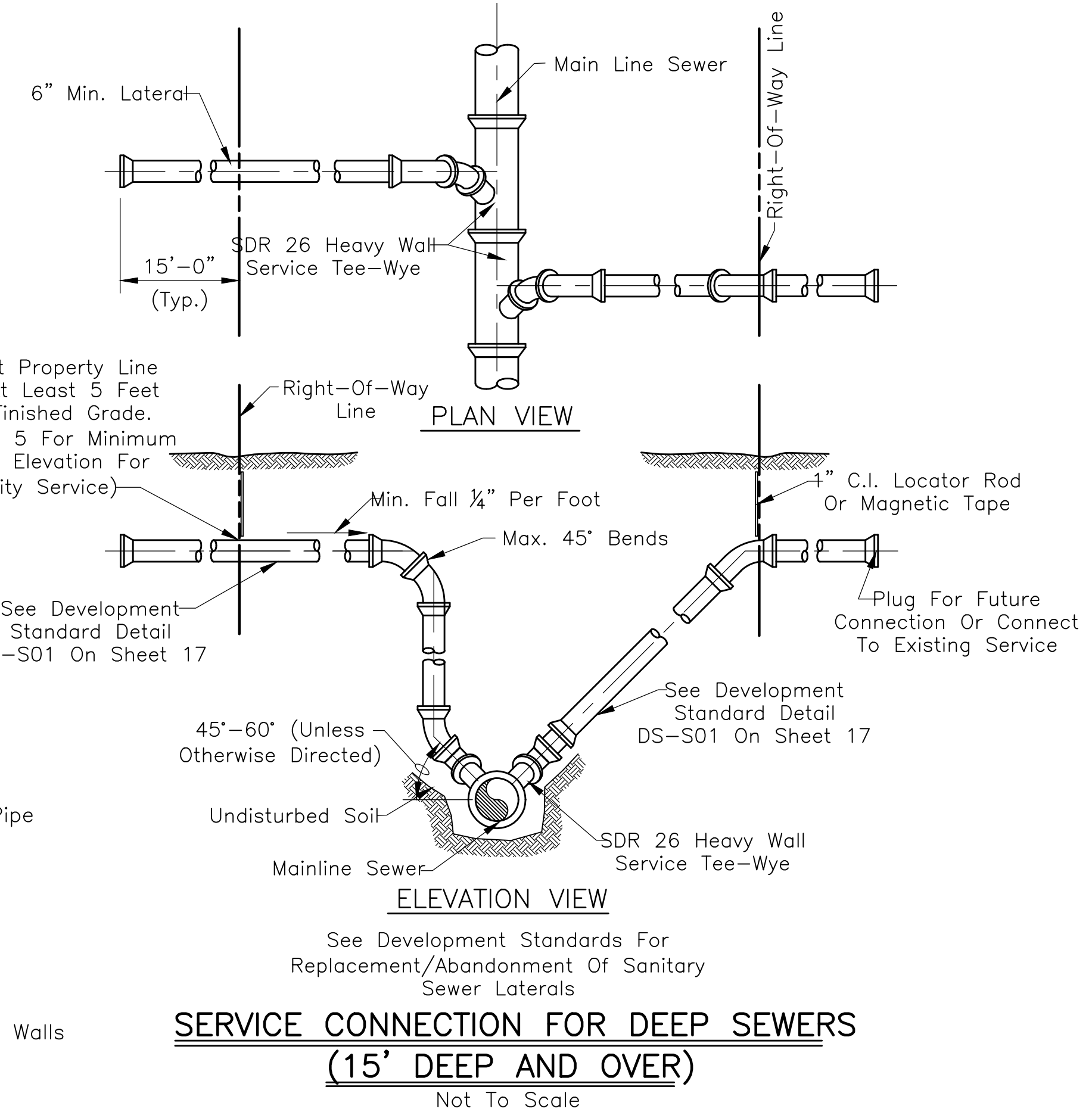

**REVISIONS**

Rev. No.	Description	Date

RECOMMENDED FOR APPROVAL: *David Loney*, DESIGN ENGINEER, DATE: 01/01/2019

APPROVED: *James Smith*, TOWN ENGINEER, DATE: 01/01/2019

APPROVED: *James Smith*, SUPERINTENDENT OF PUBLIC WORKS, DATE: 11/1/2019



PVC LATERAL PIPE BEDDING & BACKFILL TABLE**					
Bedding/Backfill Zone As Indicated On Detail	Back Of Curb To Back Of Curb	Planting Strip Or Existing Sidewalk	Private Property For Repair/Replace	Future Sidewalk Under 6 Month Rule*	Private Property Under 6 Month Rule*
Zone D Trench Backfill Compacted Per Table	Flowable Fill Or Same As Zone 'B'	Flowable Fill Or Same As Zone 'B'	Approved Excavated Material @ 85% Standard Proctor	Approved Excavated Material @ 85% Standard Proctor	Approved Excavated Material @ 85% Standard Proctor
Zone C Upper Pipe Zone Bedding Hand Tamped Or Walked In	Flowable Fill Or Same As Zone 'B'	Flowable Fill Or Same As Zone 'B'	"B"-Borrow Or Well-Graded Sand	#8 Crushed Stone Or #8 Fractured Face Aggregate	#8 Crushed Stone Or #8 Fractured Face Aggregate
Zone B Lower 1/2 O.D. Bedding Hand Tamped Or Walked In	#8 Crushed Stone Or #8 Fractured Face Aggregate	#8 Crushed Stone Or #8 Fractured Face Aggregate	"B"-Borrow Or Well-Graded Sand	#8 Crushed Stone Or #8 Fractured Face Aggregate	#8 Crushed Stone Or #8 Fractured Face Aggregate
Zone A Bedding Below Pipe Barrel Bell Hole Excavated	#8 Crushed Stone Or #8 Fractured Face Aggregate	#8 Crushed Stone Or #8 Fractured Face Aggregate	"B"-Borrow Or Well-Graded Sand	#8 Crushed Stone Or #8 Fractured Face Aggregate	#8 Crushed Stone Or #8 Fractured Face Aggregate

\*Approved Excavated Material May Be Used Under Proposed Sidewalks Provided Sidewalks Are Constructed 6 Months After Backfilling Of Trench And As Such Any Additional Lateral Pipe Built On Private Property Under Initial Sewer Construction Shall Be In Accordance With "Private Property Under 6 Month Rule" Column.

\*\*The PVC Lateral Pipe Bedding And Backfill Table Is Intended To Show Minimum Material Requirements. Flowable Fill May Be Used For Any Zone C, Or Zone D Work. "B"-Borrow May Be Used Whenever Excavated Material Is Required By Table. #8 Crushed Stone Or #8 Fractured Face Aggregate May Be Used Whenever "B"-Borrow Is Required By Table.

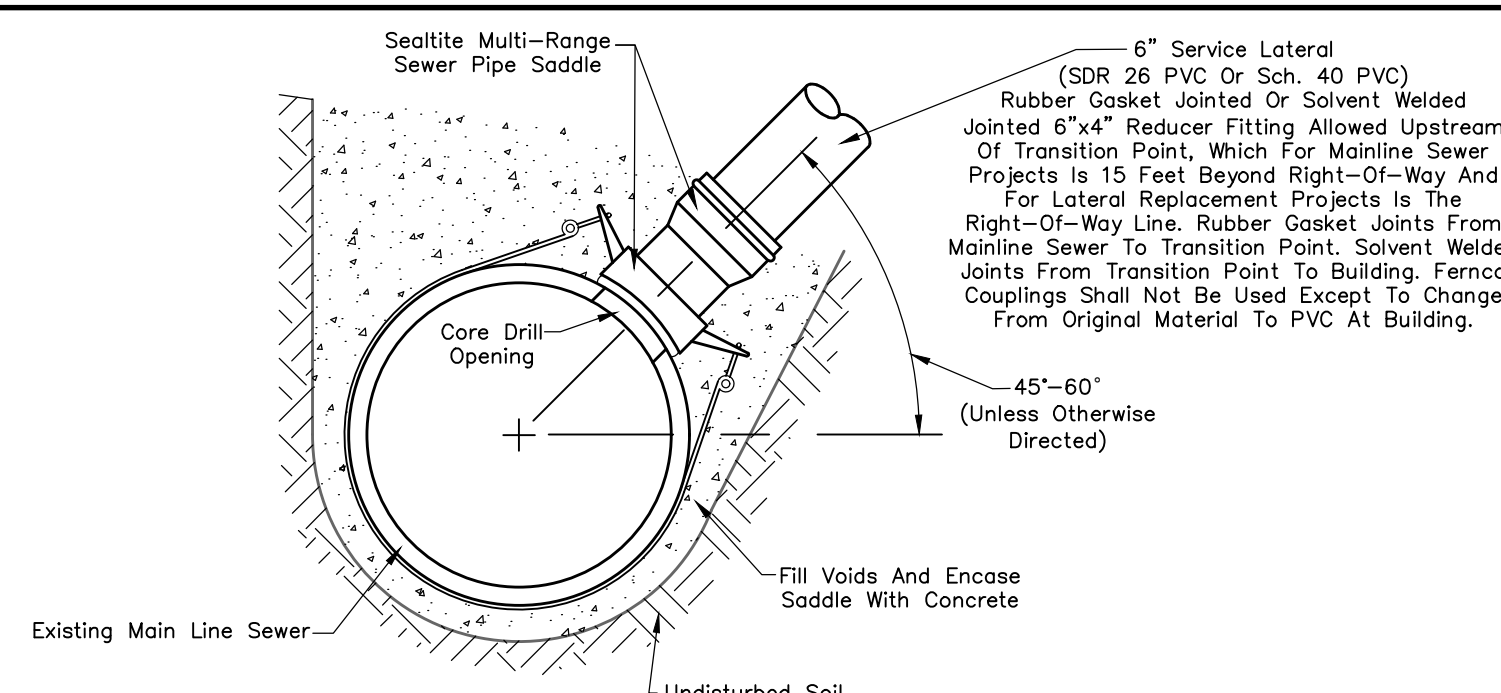
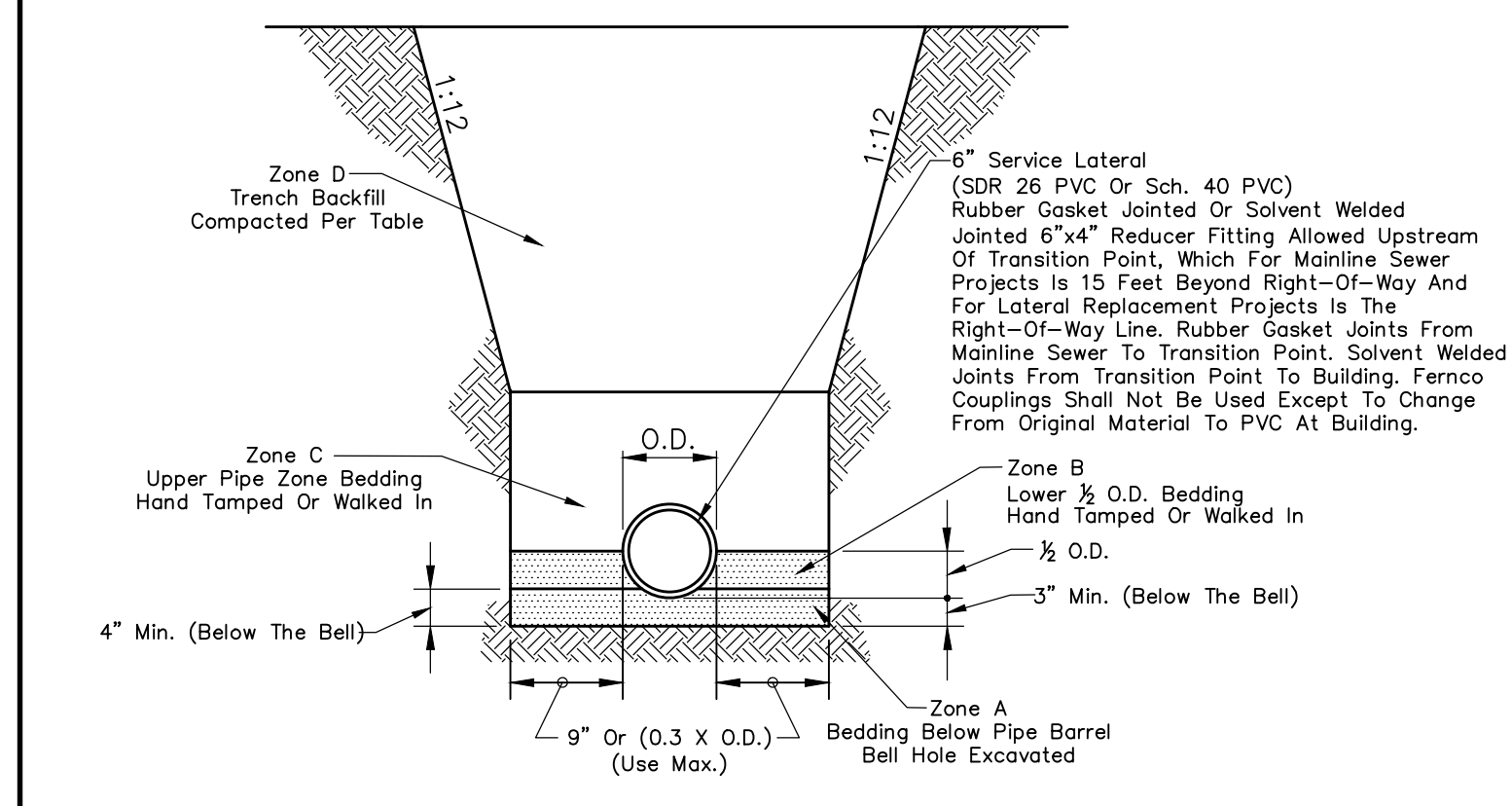

NOTE:  
1.) Sewer Pipe Saddle Shall Be General Engineering Company Sealite Type "J" For Laterals Connecting To Existing Mainline Sanitary Sewer With A 6.275" OD To 30.00" OD.  
2.) Sewer Pipe Saddle Shall Be General Engineering Company Sealite Type "C" For Laterals Connecting To Existing Mainline Sanitary Sewer Over 30.00" OD.

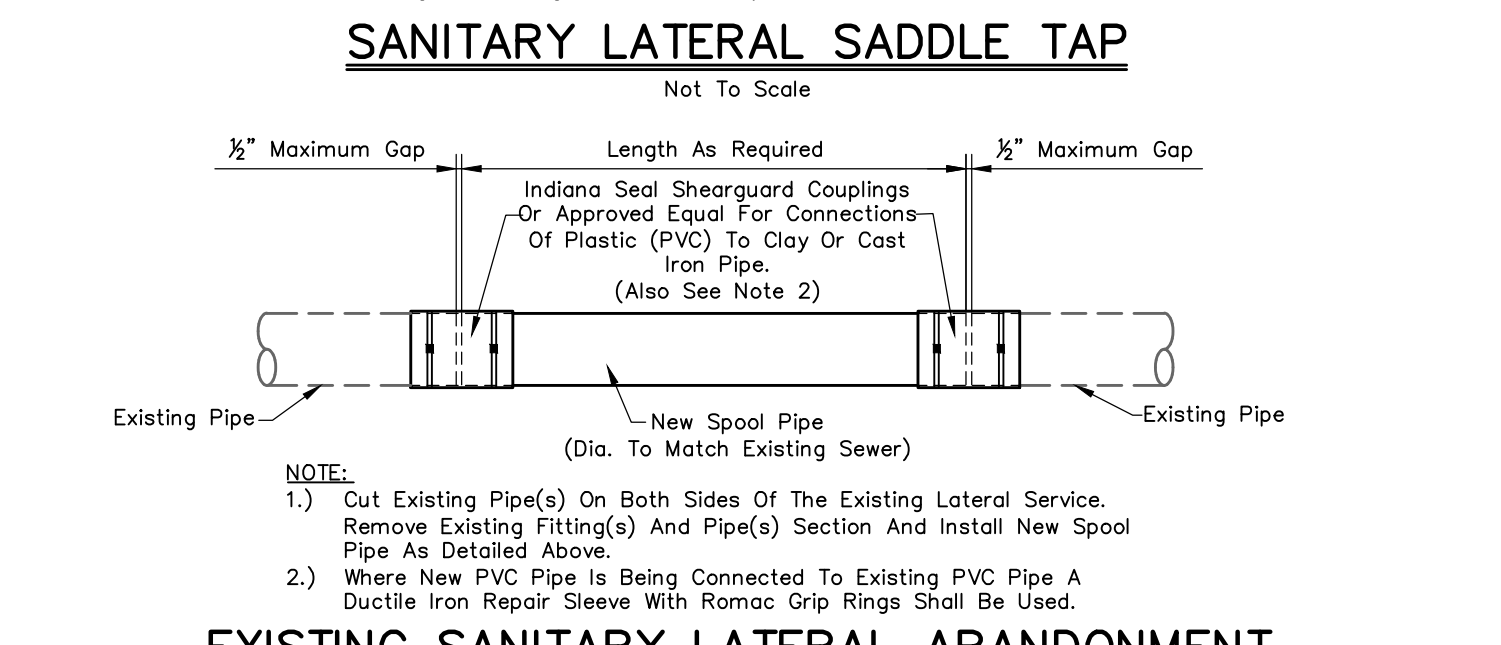

NOTE:  
1.) Cut Existing Pipe(s) On Both Sides Of The Existing Lateral Service. Remove Existing Fitting(s) And Pipe(s) Section And Install New Spool Pipe As Detailed Above.  
2.) Where New PVC Pipe Is Being Connected To Existing PVC Pipe A Ductile Iron Repair Sleeve With Romac Grip Rings Shall Be Used.

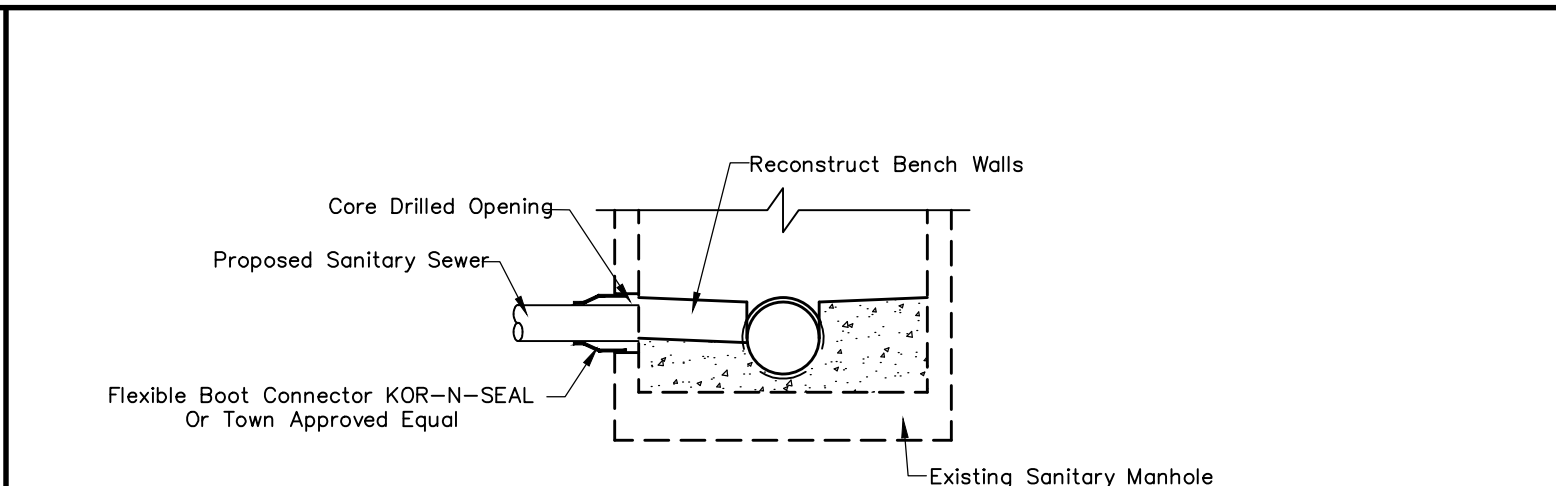

NOTE:  
1.) Cut Existing Pipe(s) On The Side Of The Proposed Manhole. Remove Existing Pipe(s) Section And Install Manhole Base. Proceed With Typical Connections And Manhole Construction.  
2.) Where New PVC Pipe Is Being Connected To Existing PVC Pipe A Ductile Iron Repair Sleeve With Romac Grip Rings Shall Be Used.

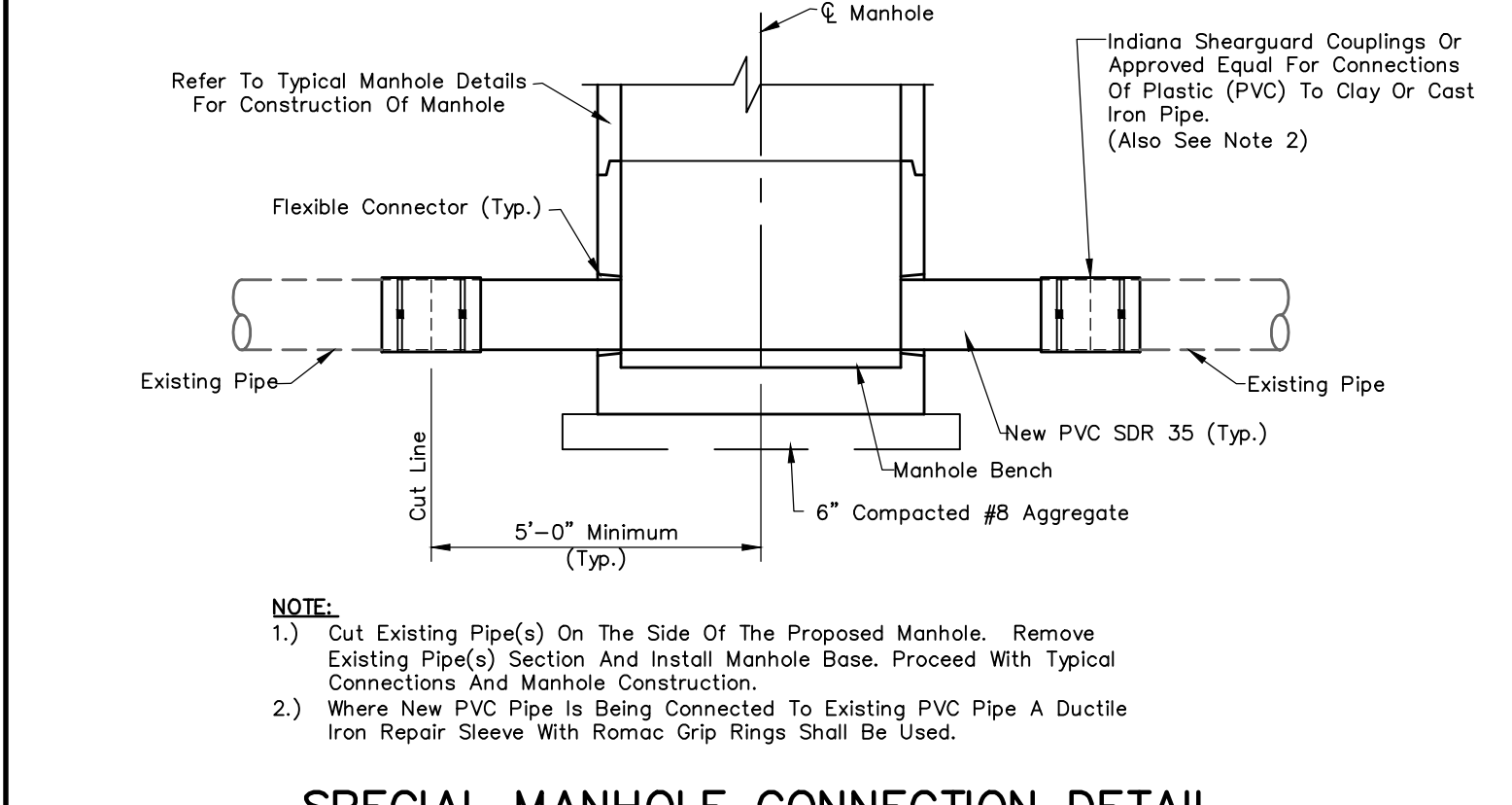

NOTE:  
1.) The Tracer Wire Shall Be 10 Gauge, Direct Bury, Solid Copper Wire With A Minimum 35 Mil. Polyethylene Insulation.  
2.) 2" to 6" Of Separation Is Recommended Between Force Main And Wire.  
3.) Tracer Wire Risers Shall Be Placed At A 400' Max Spacing Interval.  
4.) Install Tracer Wire As A Single Continuous Wire. Splicing Of Wire, If Necessary, Shall Be Done In Such A Way To Produce An Electrically And Mechanically Sound Joint.

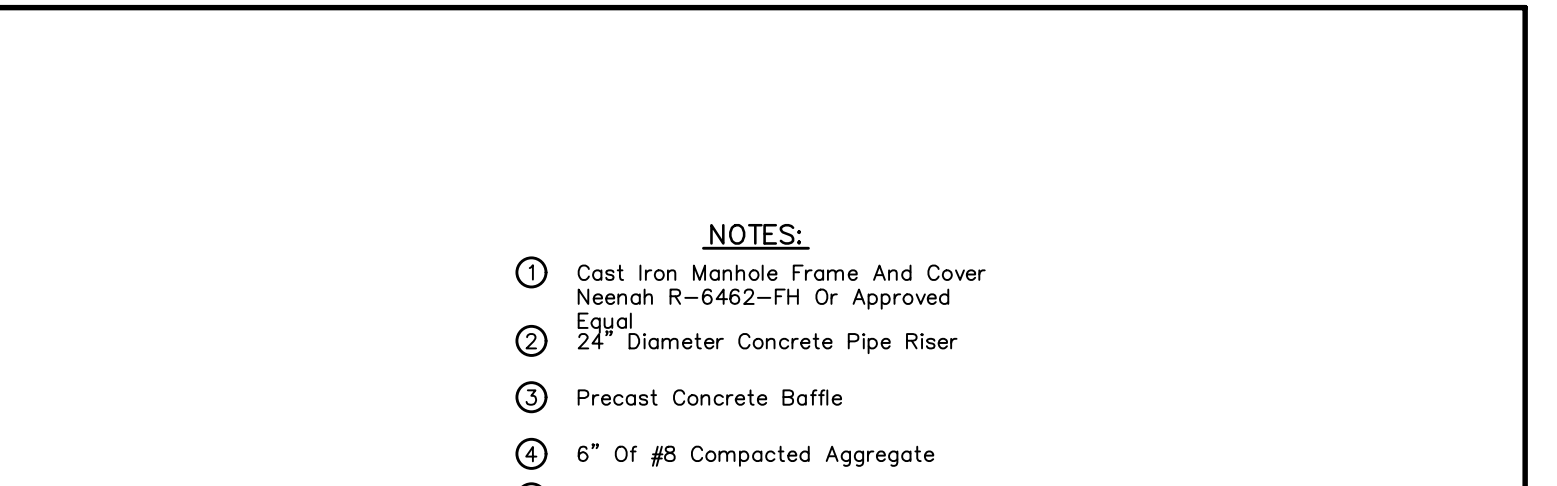

NOTE:  
1.) Cast Iron Manhole Frame And Cover Neenah R-6462-FH Or Approved Equal  
2.) 24" Diameter Concrete Pipe Riser  
3.) Precast Concrete Baffle  
4.) 6" Of #8 Compacted Aggregate  
5.) Precast Concrete Structure Designed For H-20 Loading. (Must Be Approved By The Authority Having Jurisdiction)

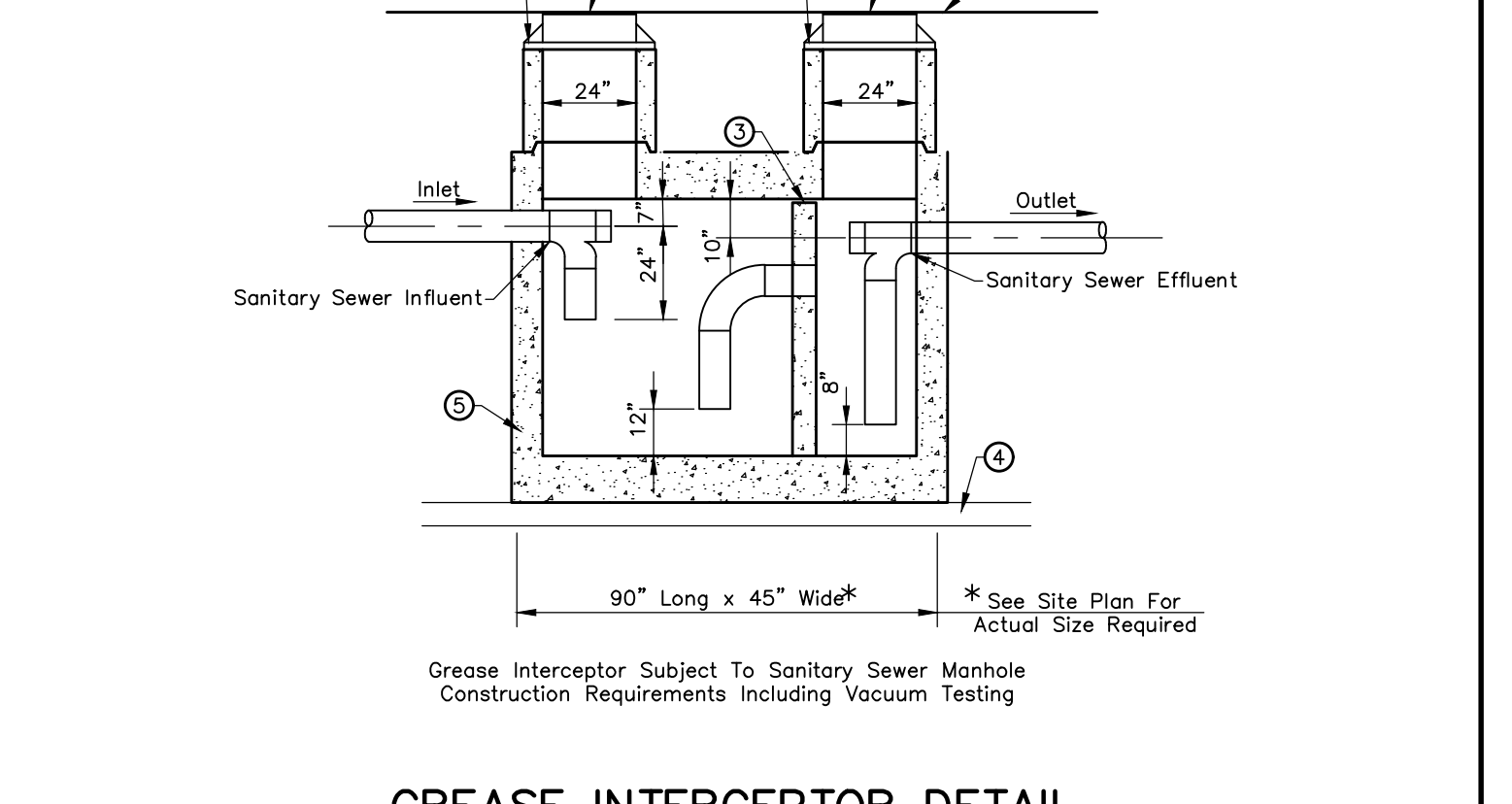

NOTE:  
1.) Fiberglass Inside Drop Bowl As Manufactured By Reliner/Duran Inc. Or Town Approved Equal.  
2.) Inside Drop Connections May Only Be Used When Connecting To Existing Sanitary Sewer Manholes

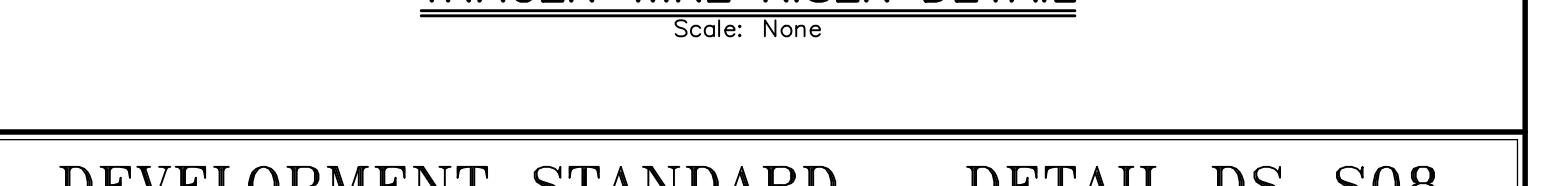
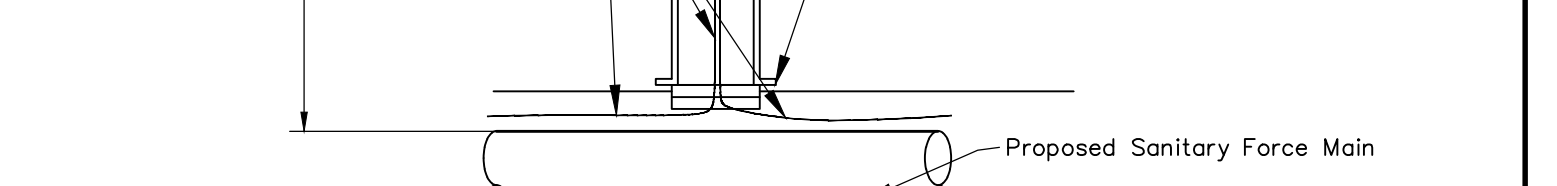
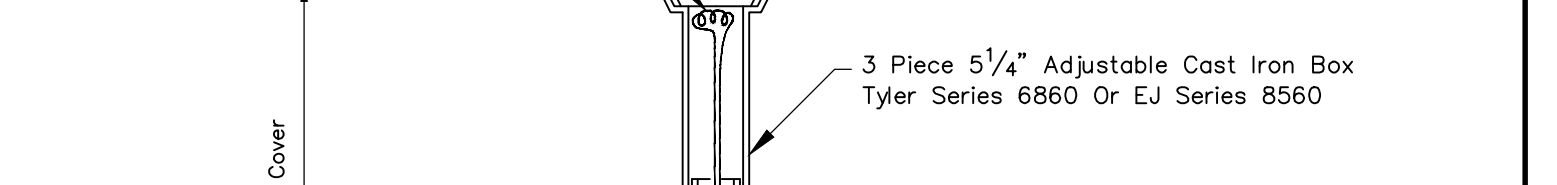
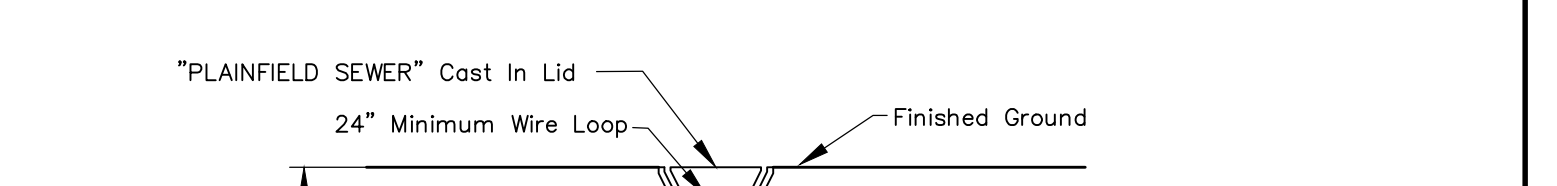
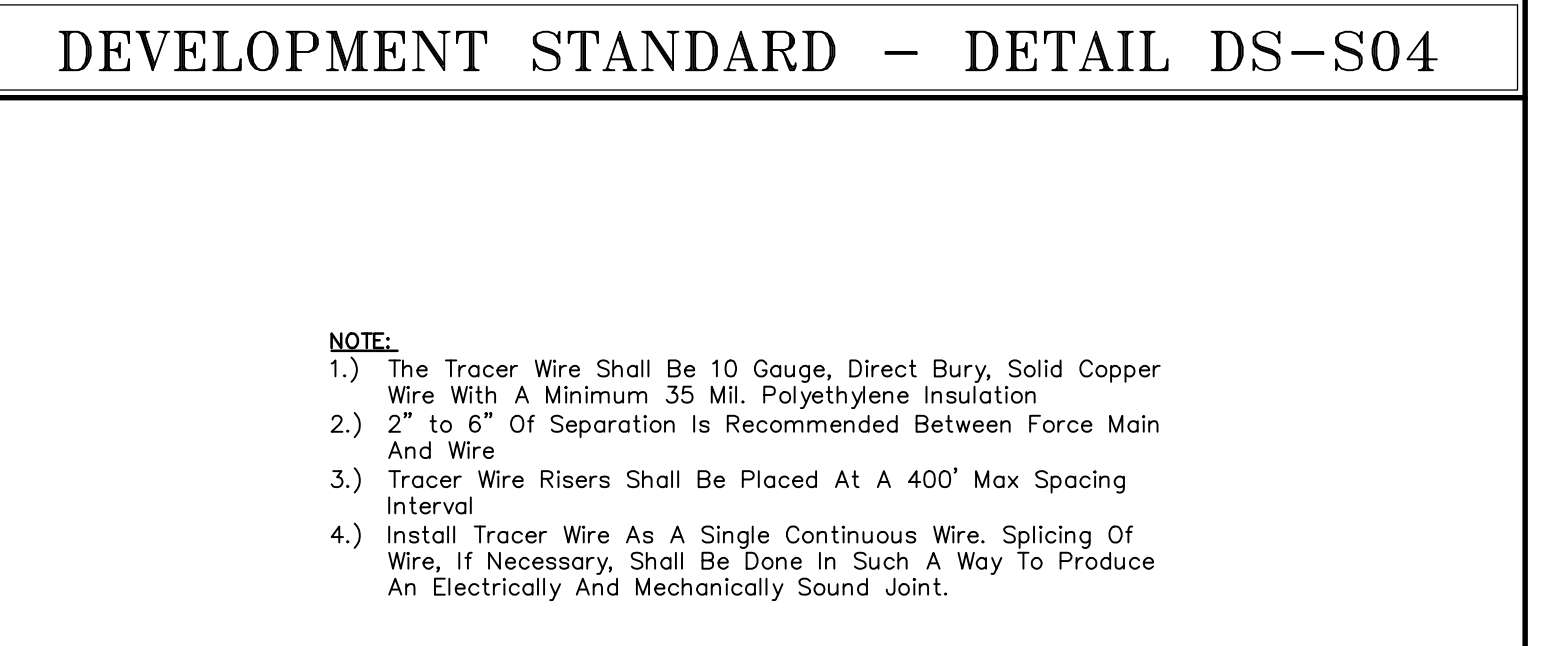

REVISIONS		
Rev. No.	Description	Date

DAVID LAHEY REGISTERED PROFESSIONAL ENGINEER No. PE19700663 STATE OF INDIANA

RECOMMENDED FOR APPROVAL: *David Lahey* DESIGN ENGINEER DATE: 01/01/2019

APPROVED: *James Smith* TOWN ENGINEER DATE: 01/01/2019

APPROVED: *James Smith* SUPERINTENDENT OF PUBLIC WORKS DATE: 11/1/2019

**LOW PRESSURE SEWER DESIGN.**

1. Calculations Shall Be Developed For LPS System Design Including The Following:
  - a. Topographical Map
  - b. Soil Conditions
  - c. Frost Depth
  - d. Water Table
  - e. Applicable Codes
  - f. Discharge Location
  - g. Lot Layout
  - h. Total Number Of Lots
  - i. Dwelling Types
  - j. Use And Flow Factors
  - k. Area Development Sequence And Timetable
2. Grinder Pumps Shall Be Sized Based Upon Recommended Flow In GPD And Must Consider The Following:
  - a. Wet Well And Discharge Piping Must Be Protected From Freezing
  - b. Model And Basin Size Must Be Appropriate For Incoming Peak Flows
  - c. Appropriate Alarm Devices Must Be Used
3. Grinder Pumps Shall Be Owned By The Property Owner, Not The Town Of Plainfield.
4. Power For Grinder Pumps Shall Be Provided By Property Owner.
5. Pipe Shall Be Either PVC SDR 21 Or HDPE DR 11.
6. Air/Vacuum Valves Shall Be Installed At All System High Points And Significant Changes In Grade.
7. Air Release Valves Shall Be Installed At Intervals Of 2,000 Feet On All Horizontal Runs That Lack A Clearly Defined High Point.
8. Air Release Valves Shall Be Installed At The Beginning Of Each Downward Leg In The System That Exhibits A 30-Foot Or More Drop.
9. Cleanout And Flushing Stations Shall Be Incorporated Into The Pipe Layout. Cleanouts Shall Be Installed At The Terminal End Of Each Main, At Every 1,000 Feet On Straight Runs Of Pipe, And Whenever Two Or More Mains Come Together And Feed Into Another Main.
10. A Pipe Schedule And Zone Analysis Shall Be Developed To Ensure The Design Conforms With A Criteria Of Flow Velocity Greater Than Or Equal To 2.0 Feet Per Second And Total Design Head Of Less Than Or Equal To 185 Feet.

**LOW PRESSURE SEWER DESIGN**

Scale: None

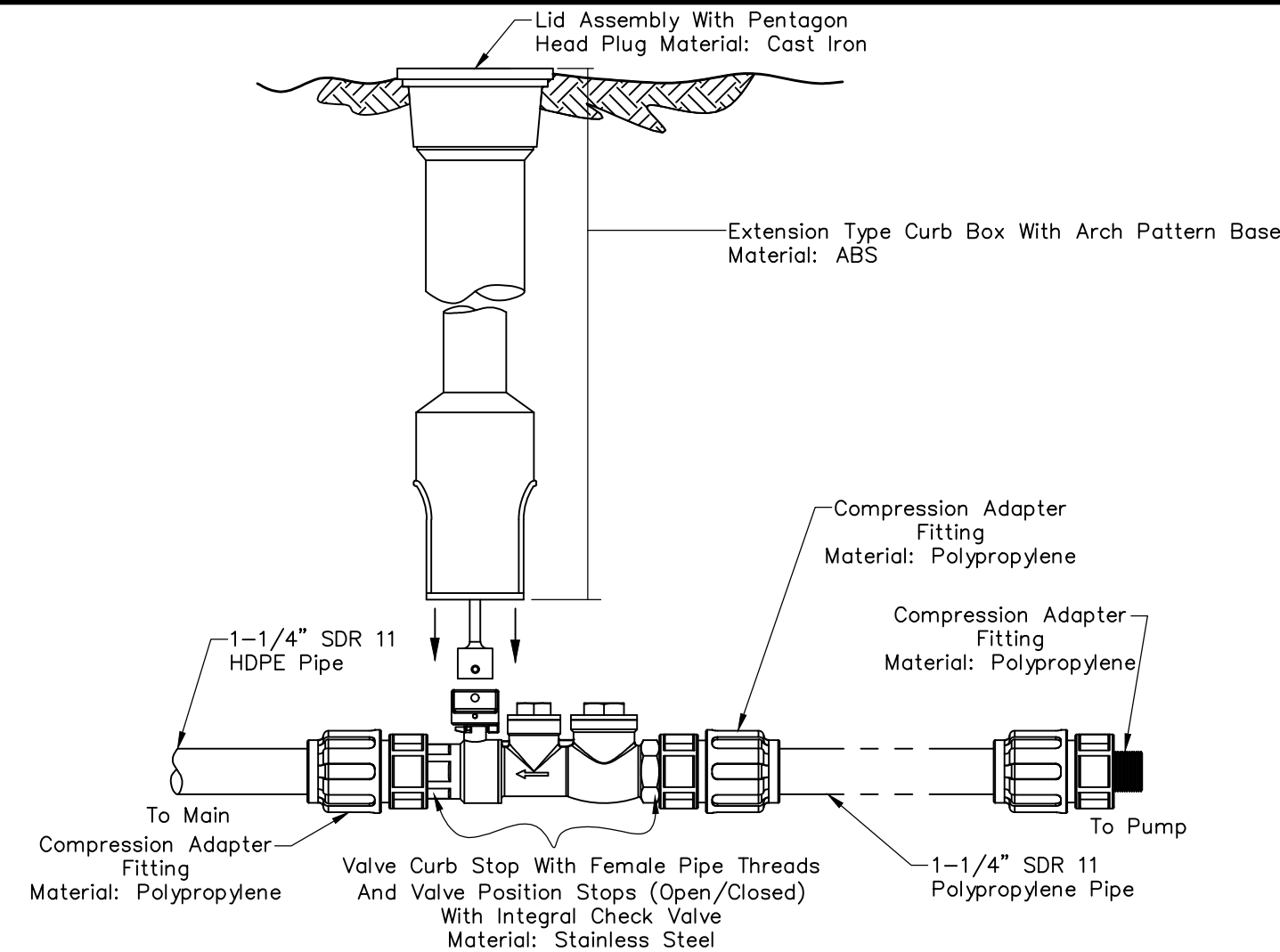

- NOTE:**
1. SS Curb Stop/Check Valve And Fittings Are Provided Separately.
  2. To Assemble, Apply A Double Layer Of Teflon Tape, And A Layer Of Pipe Dope To The Threads On Plastic Fittings And Install Per The Manufacturer's Instructions.
  3. Assembly Is To Be Pressure Tested.
  4. Assembly Is To Be Used With SDR11 HDPE Pipe.

**STAINLESS STEEL LATERAL KIT  
1-1/4\"/>**

Scale: None

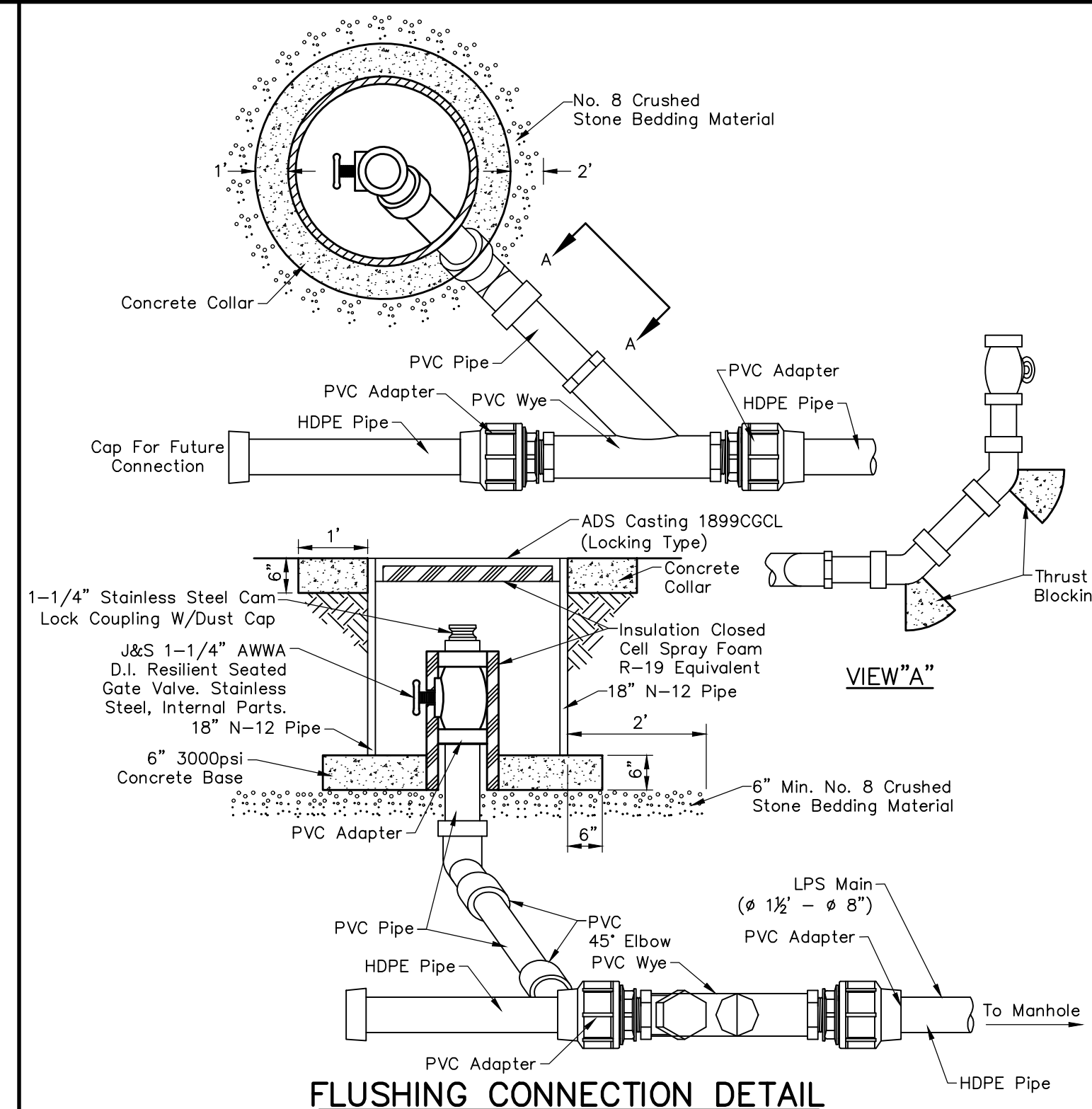

**FLUSHING CONNECTION DETAIL**

Scale: None

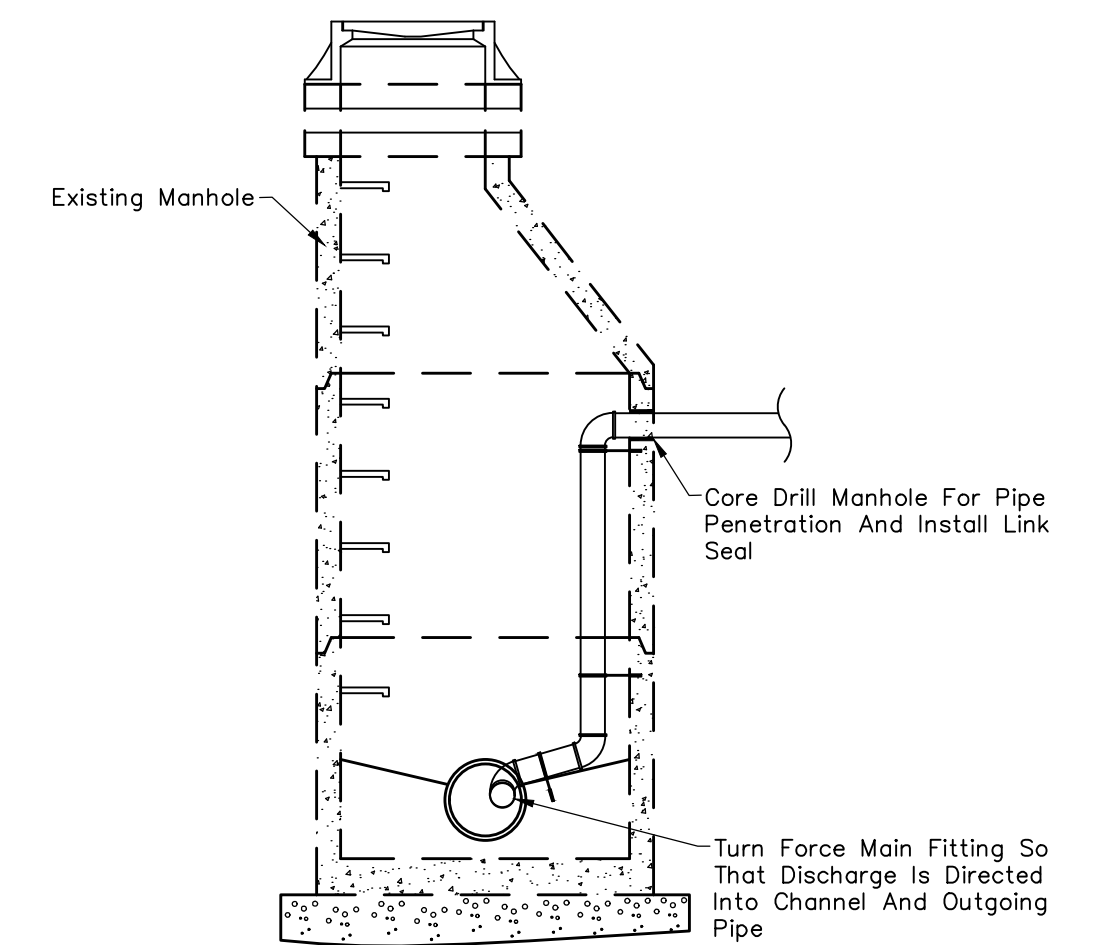

- NOTE:**
- 1.) Force Main As Specified To Be Anchored To Wall Opposite Steps With Corrosion Resistant Anchors.
  - 2.) Discharge From Force Main Shall Be Installed Over Or Directed To The Flow Line Of The Manhole With Appropriate Fittings Depending On The Orientation On The Force Main Penetration With The Flow Line.
  - 3.) Discharge Shall Not Be Directed Onto The Bench Wall!
  - 4.) Tracer Wire Shall Be Installed Per Tracer Wire Riser Detail on Sheet 13.

**SANITARY MANHOLE CONNECTION DETAIL**

Scale: None

**DEVELOPMENT STANDARD - DETAIL DS-S09**

**DEVELOPMENT STANDARD - DETAIL DS-S10**

**DEVELOPMENT STANDARD - DETAIL DS-S11**

**DEVELOPMENT STANDARD - DETAIL DS-S12**

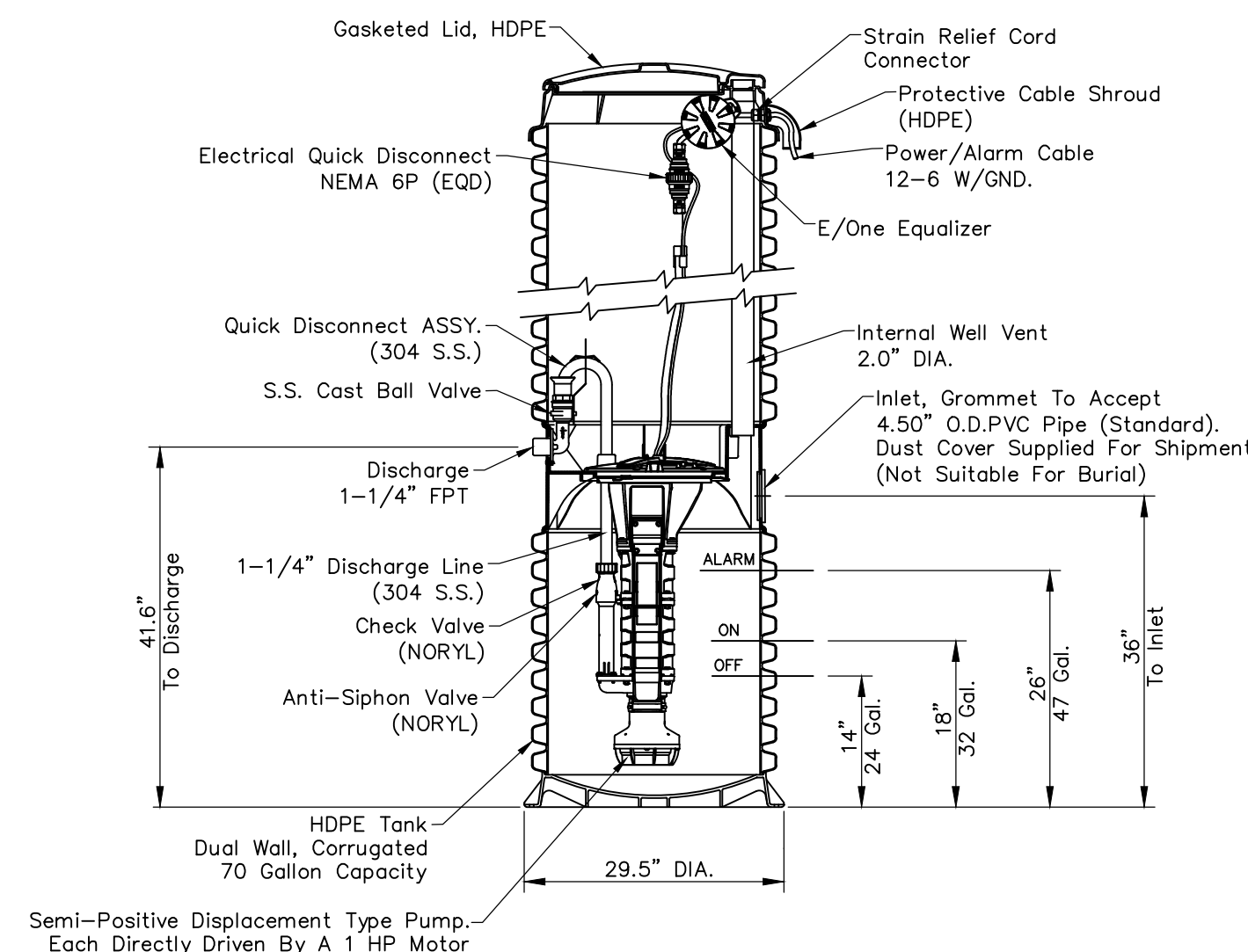

**GRINDER PUMP STATION DETAIL**

Scale: None

- NOTE:**
- 1.) Concrete Ballast May Be Required See Installation Instruction For Details.
  - 2.) Dimensions Are For Reference Only.

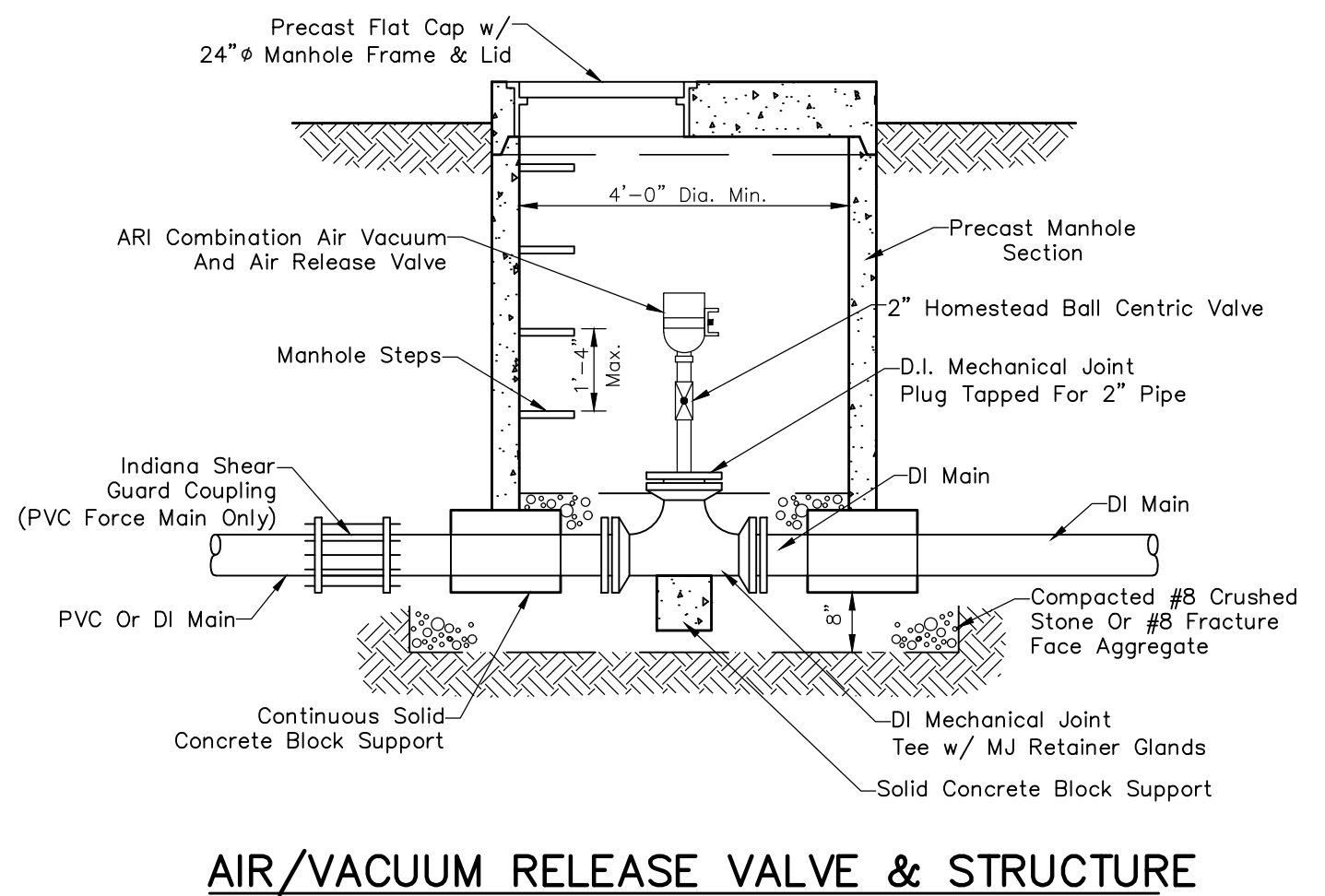

**AIR/VACUUM RELEASE VALVE & STRUCTURE**

Scale: None

**DEVELOPMENT STANDARD - DETAIL DS-S13**

**DEVELOPMENT STANDARD - DETAIL DS-S14**

REVISIONS		
Rev. No.	Description	Date

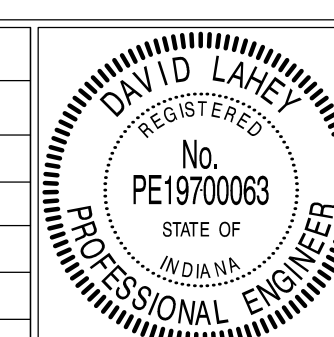

RECOMMENDED FOR APPROVAL	<i>David L. Hays</i>	DESIGN ENGINEER	01/01/2019	DATE
APPROVED	<i>James C. Smith</i>	TOWN ENGINEER	01/01/2019	DATE
APPROVED	<i>James C. Smith</i>	SUPERINTENDENT OF PUBLIC WORKS	11/1/2019	DATE

TOWN OF PLAINFIELD  
SANITARY SEWER (S)  
DEVELOPMENT STANDARDS

SHEET  
18  
OF  
25

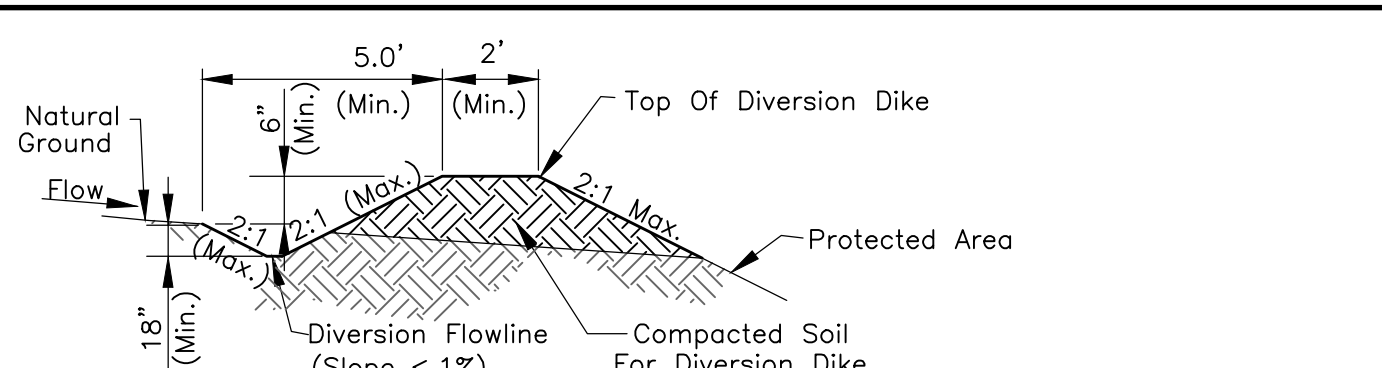

**Notes:**

**Installation:**  
Lay Out The Diversion By Setting Grade And Alignment To Fit Site Needs And Topography, Maintaining A Stable, Positive Channel Grade Towards The Outlet.

Remove And Properly Dispose Of Brush, Trees, And Other Debris From The Foundation Area.

Construct The Diversion To Dimensions And Grades Shown In The Construction Plans.

Construct The Diversion Ridge In Six To Eight-Inch Lifts. Compact Each Lift By Driving Wheels Of Construction Equipment Along The Ridge. Overfill And Compact The Ridge To Design Height Plus 10 Percent To Allow For Settlement.

Stabilize Outlets Prior To Or During Construction Of The Diversion, Diverting Sediment-Laden Storm Water Flow To A Temporary Sediment Trap Or A Temporary Dry Sediment Basin.

**Maintenance:**  
Inspect Within 24 Hours Of Each Rain Event And At Least Once Every Seven Calendar Days.

Remove Sediment From Channel To Maintain Positive Grade.

Check Outlets And Make Necessary Repairs Immediately.

Adjust Ridge Height To Prevent Overtopping.

**TEMPORARY DIVERSION**  
Not To Scale

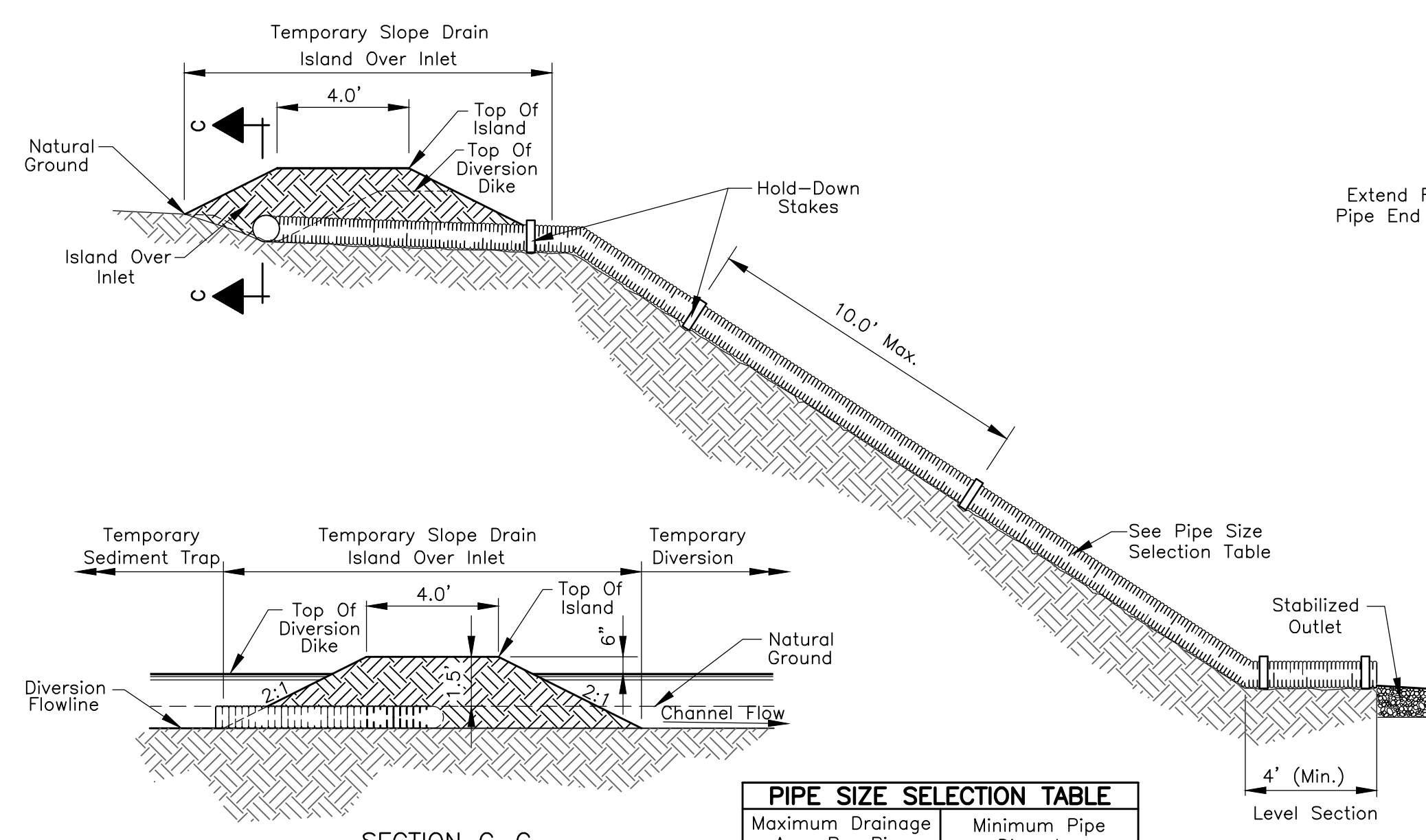

**Notes:**

**Installation:**  
Place Temporary Slope Drains On Undisturbed Soil Or Well Compacted Fill. Set The Slope Drain Inlet At The Bottom Of The Diversion Channels. Connect The Pipe To The Inlet Section.

Construct The Diversion Ridge By Placing Fill Over The Pipe In 6 Inch Lifts. Compact Each Lift By Hand Tamping Under And Around The Inlet, And Along The Pipe.

Make The Top Of The Fill 6 Inches Higher Than The Adjoining Diversion.

Make All Pipe Connections Watertight And Secure So That Joints Will Not Separate In Use.

Anchor The Pipe To The Face Of The Slope With Stakes Spaced No More Than 10 Feet Apart. Extend The Pipe Beyond The Toe Of Slope To A Stable Grade. Protect The Outlet From Erosion.

Grade The Diversion Channel At The Top Of The Slope Toward The Temporary Slope Drain (Slope <2%).

Stabilize All Disturbed Areas Following Installation.

**Maintenance:**  
Inspect Weekly And Following Each Storm Event. (Remove Sediment From The Channel And Reinforce The Ridge As Needed.)

Check The Inlet For Sediment Or Trash Accumulation.

Check The Fill Over The Pipe For Settlement, Cracking, Or Piping Holes; Repair Immediately.

Check For Holes Where The Pipe Emerges From The Dike; Repair Immediately.

Check The Conduit For Evidence Of Leaks Or Inadequate Anchoring; Repair Immediately.

Check The Outlet For Erosion Or Sedimentation; Clean & Repair Or Extend If Necessary.

**TEMPORARY SLOPE DRAIN**  
Not To Scale

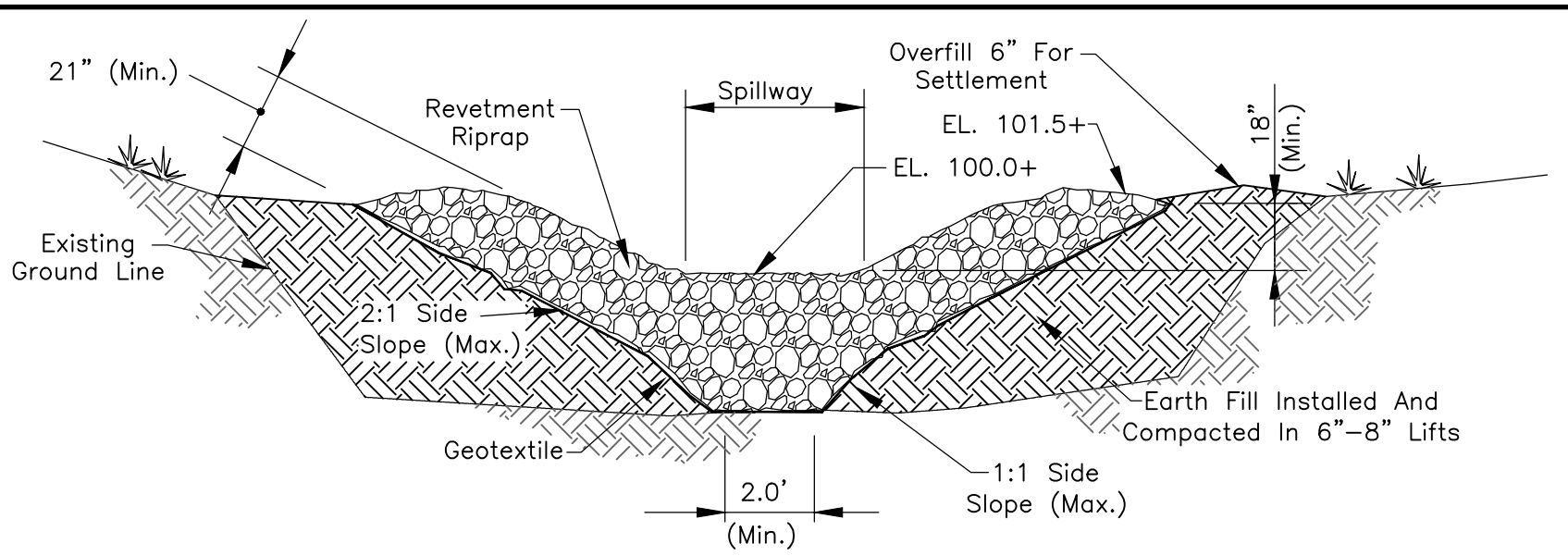

**EARTH EMBANKMENT AND STONE OUTLET SECTION**

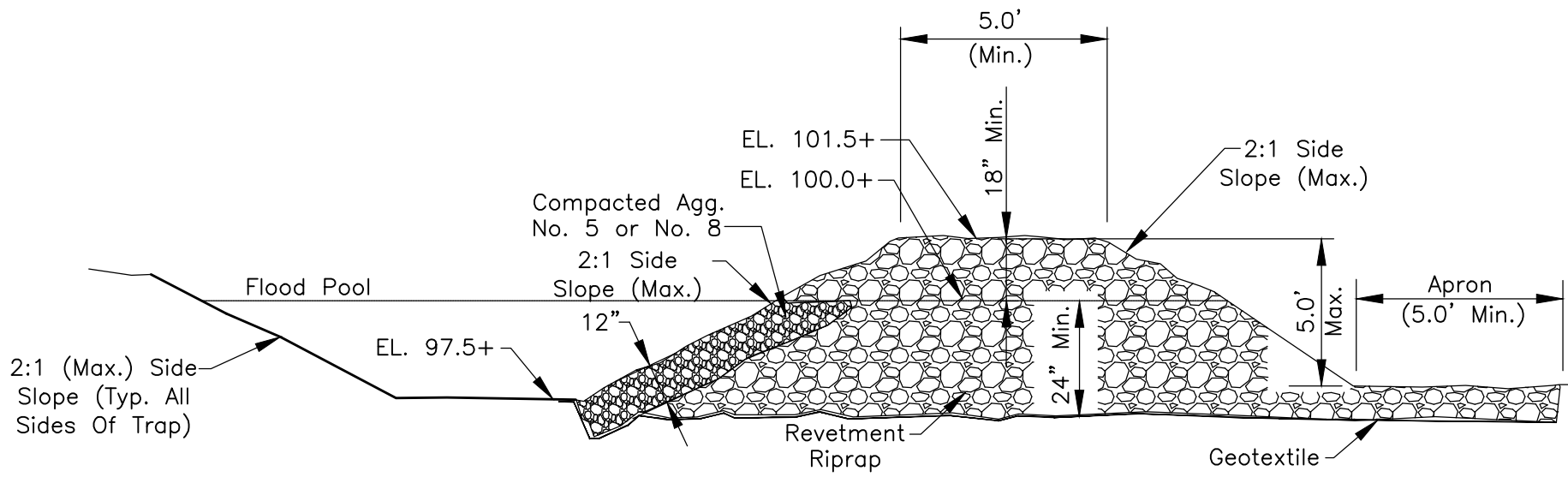

**CROSS SECTION VIEW OF THE STONE OUTLET SECTION**

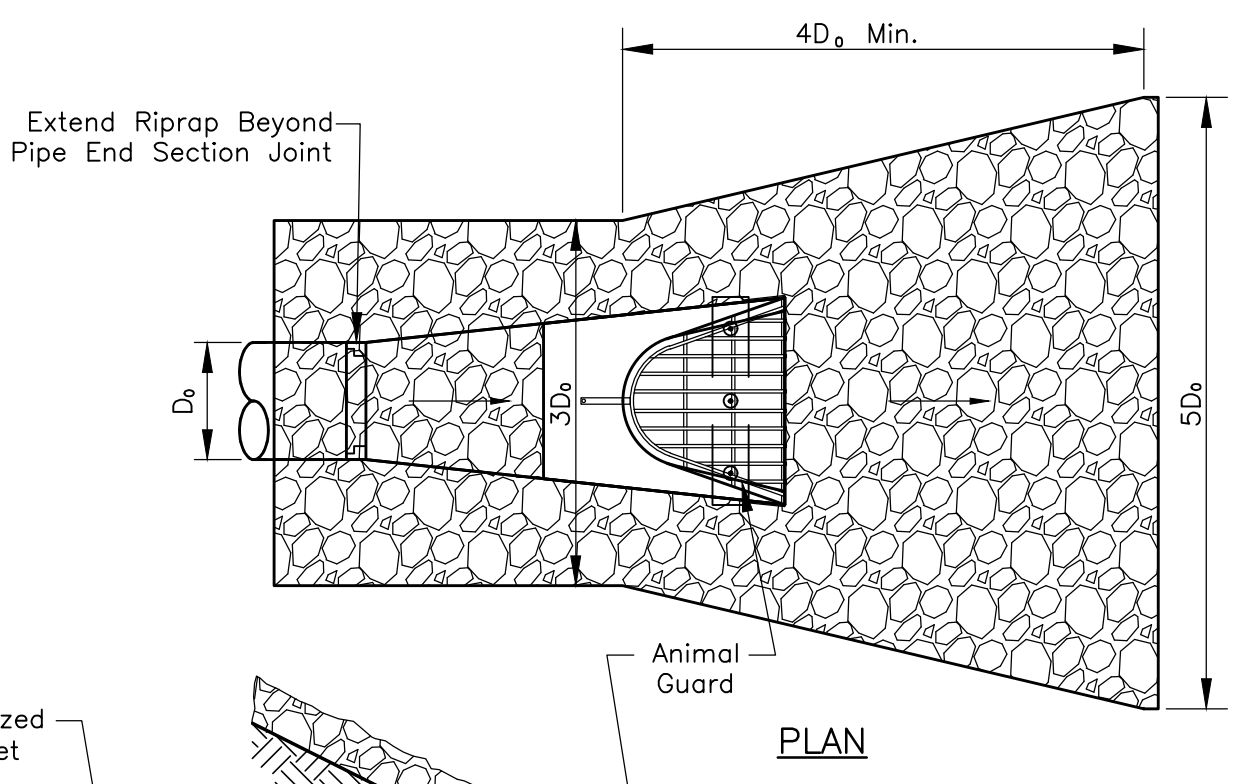

**PLAN**

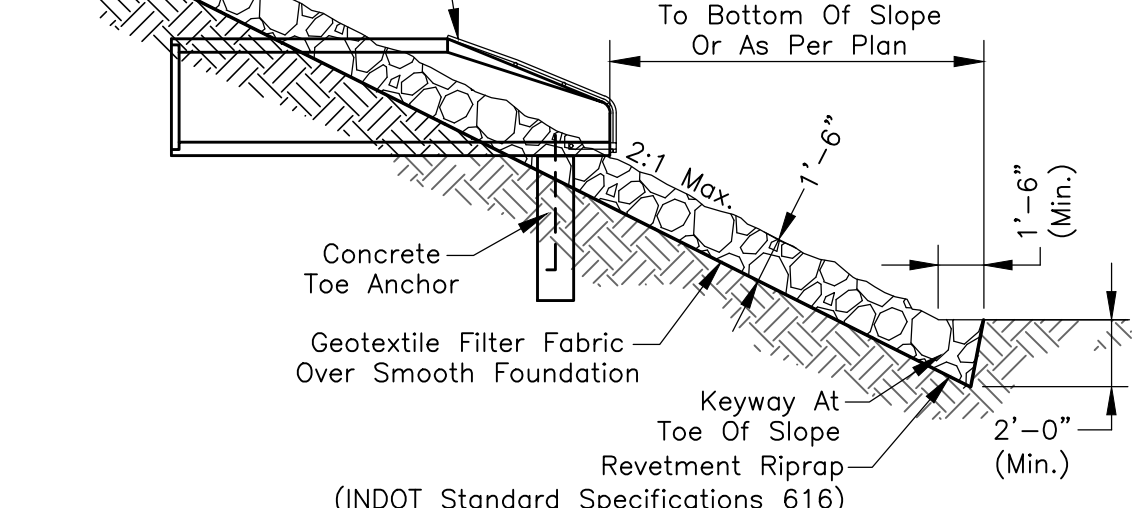

**SECTION**

**Notes:**

**Installation:**  
Excavate Only Deep Enough For Both Filter And Riprap. Compact Any Fill Material To The Density Of The Surrounding Undisturbed Soil.

Cut A Keyway In Stable Material At The Base Of The Slope To Reinforce The Toe; Keyway Depth Should Be 1 1/2 Times The Design Thickness Of The Riprap And Should Extend A Horizontal Distance Equal To The Design Thickness.

Place Geotextile Fabric On The Smoothed Foundation, Overlapping The Edges 12 Inches Min. Secure With Anchor Pins Spaced Every 3 Feet Along The Overlap.

Immediately After Installing The Filter, Add The Riprap To Full Thickness In One Operation. Do Not Dump Through Chutes Or Use Any Method That Causes Segregation Of Rock Sizes Or That Will Dislodge Or Damage The Underlying Filter Material.

If Fabric Is Damaged, Remove The Riprap And Repair By Adding Another Layer Of Fabric, Overlapping The Damaged Area By 12 Inches.

Place Smaller Rock In Voids To Form A Dense, Uniform, Well Graded Mass. Blend The Rock Surface Smoothly With The Surrounding Area To Eliminate Protrusions Or Over-Falls.

Inspect Periodically For Displaced Rock Material, Slumping, And Erosion At Edges, Especially Downstream Or Downslope.

**Maintenance:**  
Inspect Periodically For Displaced rock Material, Slumping And Erosion At Edges, Especially Downstream Or Downslope.

**PRECAST CONCRETE END SECTION W/ RIP RAP**  
Not To Scale

REVISIONS		
Rev. No.	Description	Date

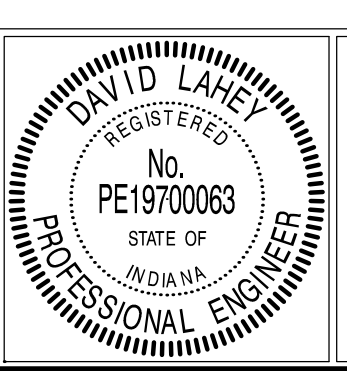

RECOMMENDED FOR APPROVAL: *[Signature]* DATE: 01/01/2019

DESIGN ENGINEER

APPROVED: *[Signature]* DATE: 01/01/2019

TOWN ENGINEER

APPROVED: *[Signature]* DATE: 1/1/19

MS4 OPERATOR

**Notes:**

The Spillway Width Varies With The Drainage Area Contributing To The Temporary Sediment Trap:

Drainage Area (acres)	Width (ft.)
1	4
2	6
3	8
4	10
5	12

The Length And Width Of The Basin Are As Shown On The Erosion Control Plan (Maximum Drainage Area Is 5 Acres).

See The Indiana Storm Water Quality Manual For Additional Information.

**Installation:**  
Clear, Grub, And Strip All Vegetation And Root Mat From The Embankment Area.

Create Embankment Using Material Free Of Roots, Rocks, Brush, And Debris. Overfill The Embankment 6 Inches To Allow For Settling.

Excavate A Trapezoidal Stone Outlet Section From The Compacted Embankment (Section A-A).

Install Geotextile And Place Specified Stone To The Lines And Grades Shown.

Stabilize The Embankment And Other Disturbed Areas With Seed And Mulch Or Another Suitable Erosion Resistant Cover.

**Maintenance:**  
Inspect Traps Weekly And Following Each Storm Event And Immediately Repair. Check Embankment For Any Erosion And Piping Holes And Repair.

Remove Sediment When It Has Accumulated To One Half The Design Depth. Check Pool Area Side Slopes For Erosion And Repair.

Replace Spillway Gravel Facing If Clogged.

Inspect Vegetation And Reseed Again, If Necessary.

Check The Spillway Depth Periodically To Ensure A Minimum 18 Inch Depth From The Lowest Point Of The Settled Embankment To Highest Point Of The Spillway Crest. Fill Any Low Areas To Maintain The Design Elevation.

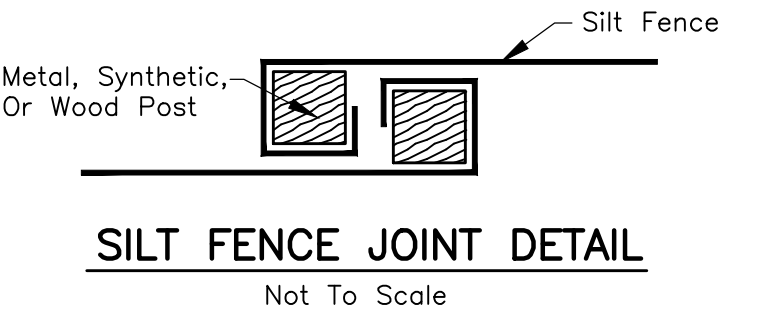

**SILT FENCE JOINT DETAIL**  
Not To Scale

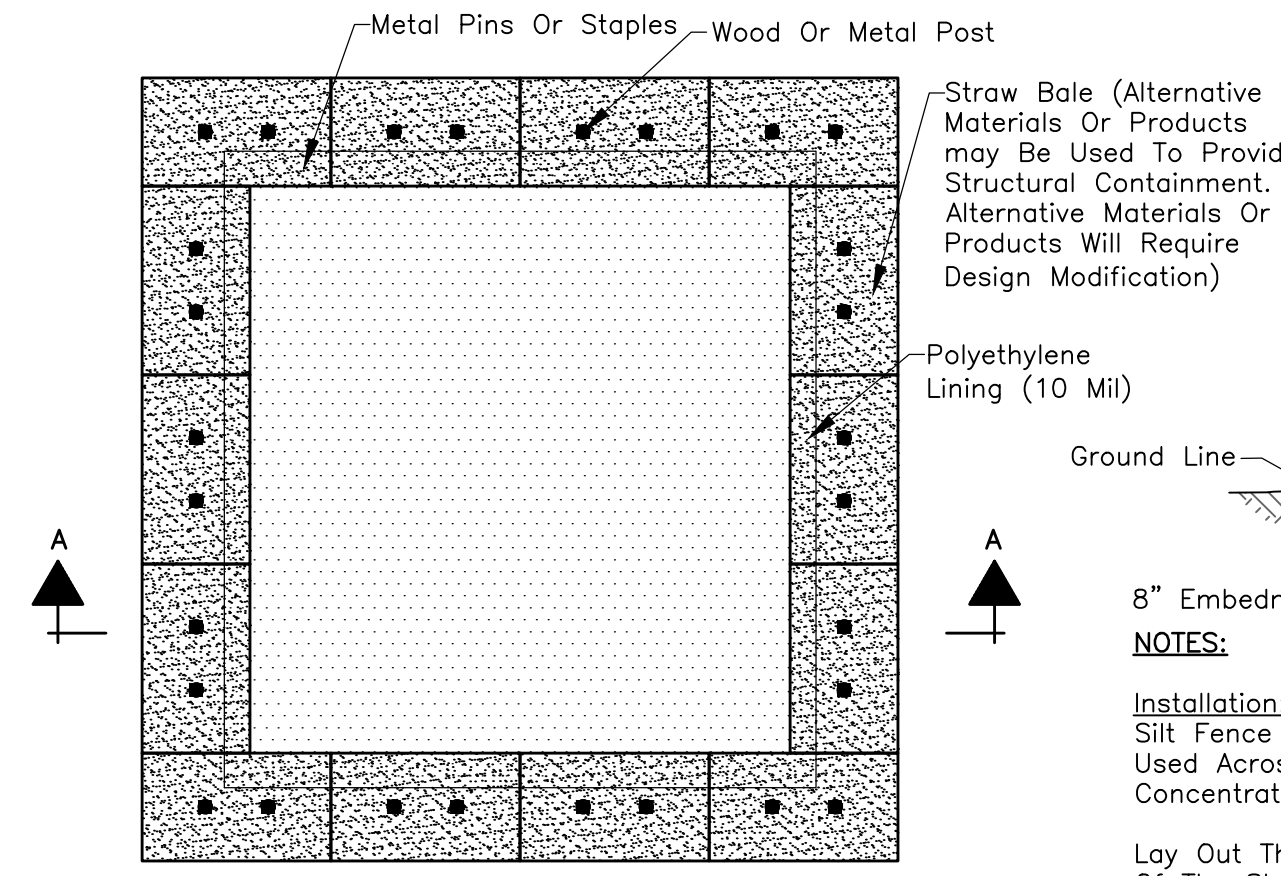

**PLAN**

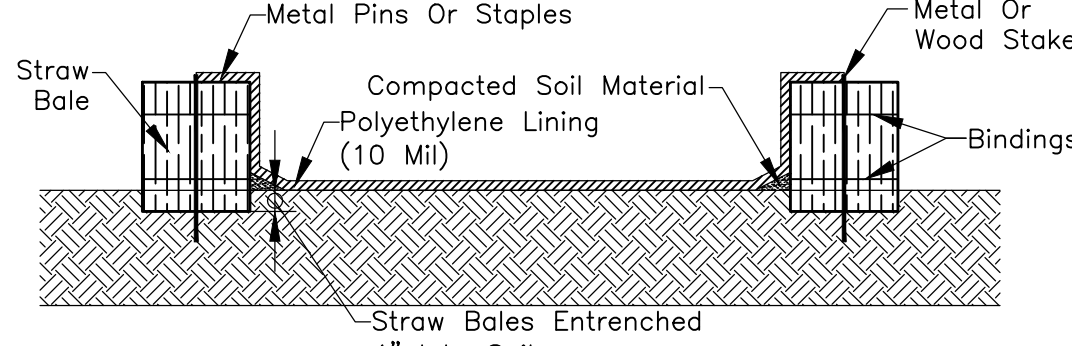

**SECTION A-A**

**CONCRETE WASHOUT**  
Not To Scale

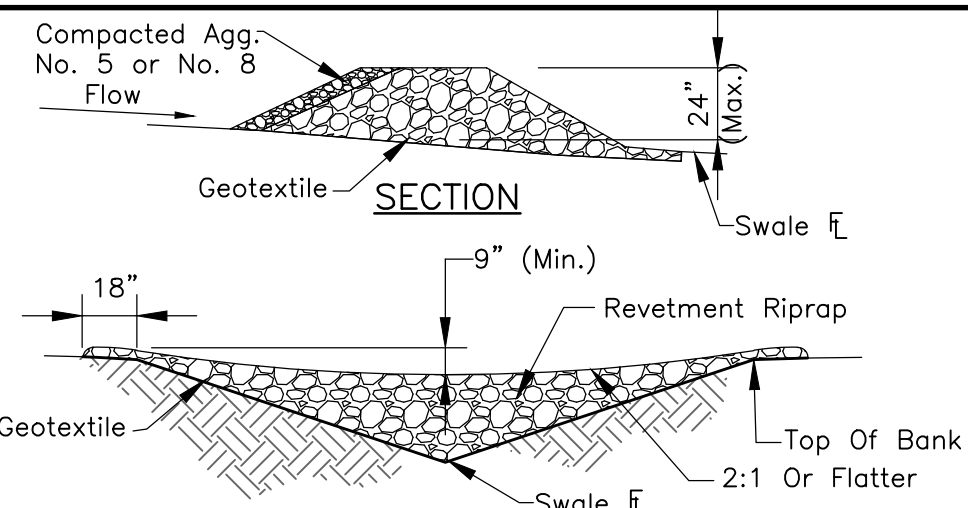

**ELEVATION**

**Notes:**

**Installation:**  
Excavate A Cutoff Trench Into The Swale Banks And Extend It A Minimum Of 18 Inches Beyond The Top Of Bank. Place The Rock In The Cutoff Trench And Channel To The Limits And Dimensions Shown.

Extend The Rock At Least 18 Inches Beyond The Top Of Bank To Keep Overflow Water From Undercutting The Dam As It Re-Enters The Channel.

Space Dams So That The Upstream Dam Toe Elevation And The Overflow Weir Of The Downstream Dam Top Elevation Are The Same. (A 1% Swale Slope Would Equal 200' Spacing)

Stabilize The Channel Above The Uppermost Dam. Erosion Resistant Lining Shall Extend At Least 6" Below Lowest Dam.

**Maintenance:**  
Inspect Check Dams And The Channel After Each Storm Event, And Repair Any Damage Immediately. If Significant Erosion Occurs Between Dams, Install A Riprap Liner In That Portion Of The Channel.

Remove Sediment Accumulated Behind Each Dam As Needed To Maintain Channel Capacity, To Allow Drainage Through The Dam, And To Prevent Large Flows From Displacing Sediment.

Add Aggregate To The Dams As Needed To Maintain Design Height And Cross Section.

When The Dams Are No Longer Needed, Remove The Aggregate And Stabilize Channel Using An Erosion Resistant Lining, If Necessary.

**ROCK CHECK DAM**  
Not To Scale

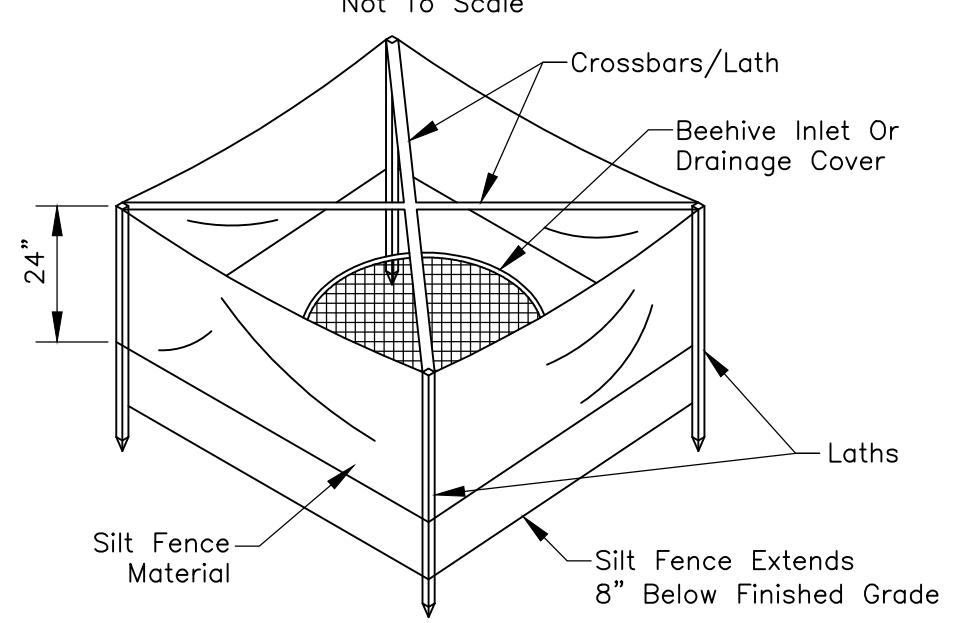

**SILT FENCE INLET PROTECTION**

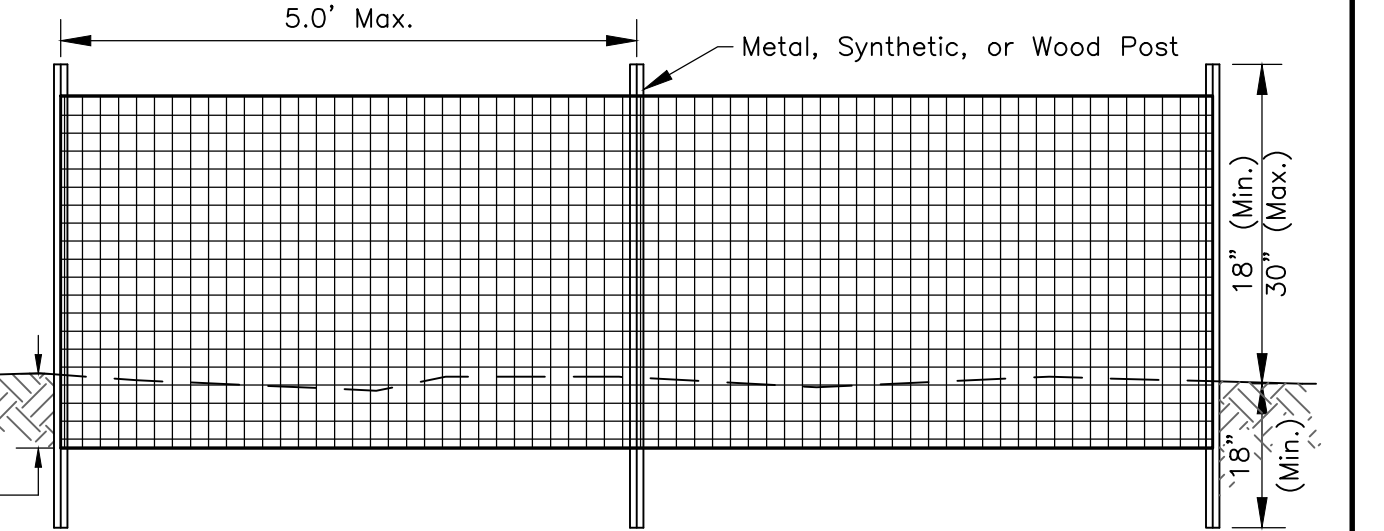

**UNSUPPORTED SILT FENCE**

**Notes:**

**Installation:**  
Silt Fence Is Not Recommended For Use As A Diversion And Should Not Be Used Across A Stream, Channel, Ditch, Swale, Or Anywhere That Concentrated Flow Is Anticipated.

Lay Out The Location Of The Fence So That It Is Parallel To The Contour Of The Slope And At Least 10 Feet Beyond The Toe Of The Slope To Provide A Sediment Storage Area. Turn The Ends Of The Fence Up Slope Such That The Point Of Contact Between The Ground And The Bottom Of The Fence End Terminates At A Higher Elevation Than The Top Of The Fence. At Its Lowest Point

Along The Entire Fence Line, Dig An 8 Inch Deep Flat Bottomed Or V-Shaped Trench. Place Fence According To Manufacturer's Recommendations.

**Maintenance:**  
Inspect The Silt Fence Weekly And After Each Storm Event.

If Fence Fabric Tears, Starts To Decompose, Or In Any Way Becomes Ineffective, Replace The Affected Portion Immediately.

Remove Deposited Sediment When It Reaches Half The Height Of The Fence At Its Lowest Point Or Is Causing The Fabric To Bulge. Take Care To Avoid Undermining The Fence During Clean Out.

After The Contributing Drainage Area Has Been Stabilized, Remove The Fence And Sediment Deposits, Bring The Disturbed Area To Grade, And Stabilize

**TRENCH DETAIL**

**SILT FENCE (SEDIMENT FENCE)**  
Not To Scale

TOWN OF PLAINFIELD

EROSION CONTROL MEASURES

SHEET

19

OF

25

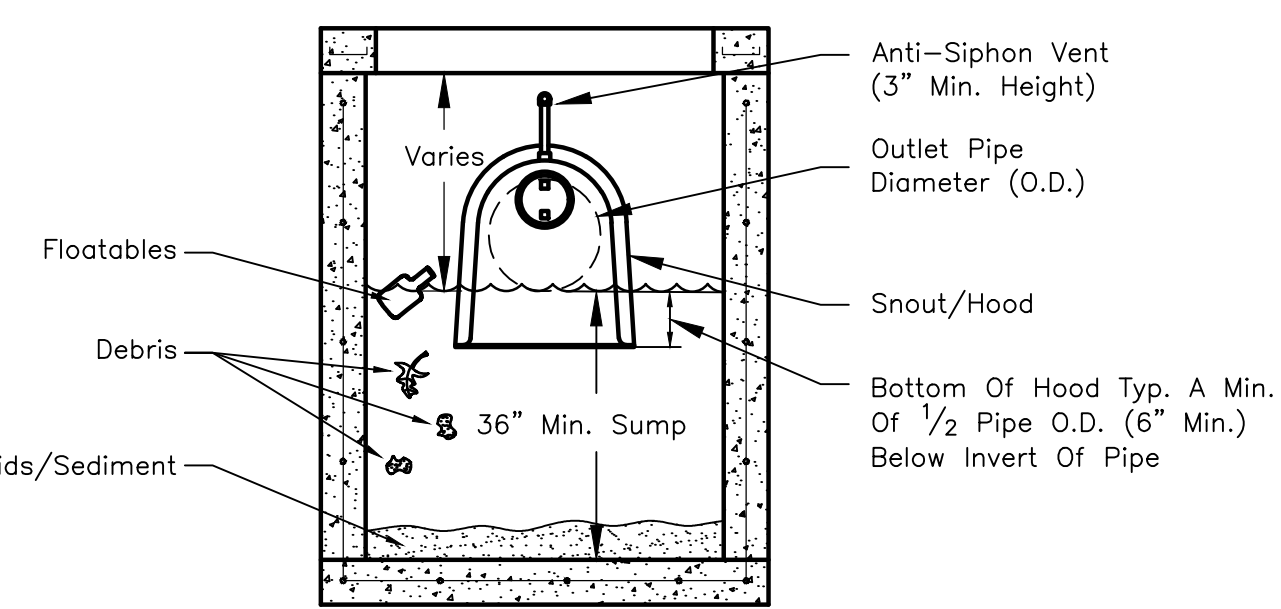

**NOTES:**

**Installation:**  
Snout/Hood Is Installed Over The Outlet Pipe Of A Catch Basin Or Stormwater Structure To Reduce Floatable Trash And Debris, Free Oils, And Other Solids From Stormwater Discharges.

Snout/Hood Shall Be Centered And Anchored Over The Outlet Pipe And Must Cover The Pipe O.D. To Ensure Proper Installation.

Structure Shall Be Sumped To Manufacturer's Recommended Depth. Minimum Sump Depth Is Typically 2.5 To 3 Times The I.D. Of The Outlet Pipe Size (Minimum Of 36").

Snout/Hood Shall Be Equipped With An Anti-Siphon Vent.

Maximum Flow And Velocity Shall NOT Exceed Manufacturer's Recommendation.

**Maintenance:**  
Sediment Depth And Surface Pollutants In The Sump Shall Be Measured Monthly And After Each Rain Event Of 1/2" Or More.

The Sump Shall Be Emptied At Least Yearly And When The Sump Is Half Full, Or Six Inches Of Floatable Pollutants Accumulate On The Surface.

The Snout/Hood Shall Be Inspected Yearly And The Anti-Siphon Vent Shall Be Flushed To Ensure It Is Clear.

**SNOUT/HOOD OIL WATER DEBRIS SEPERATOR**  
Not To Scale

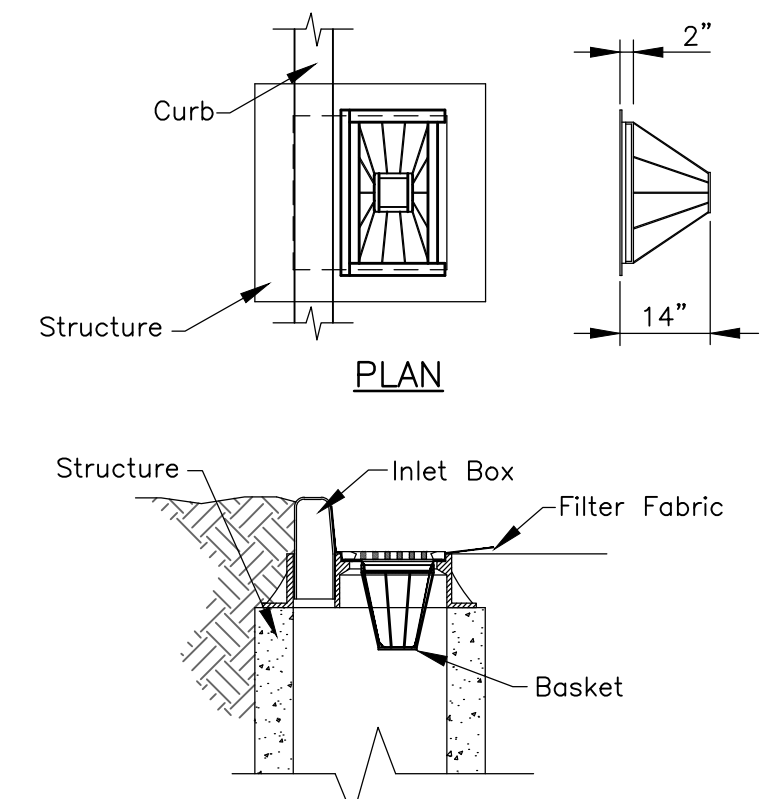

**NOTES:**

**Installation:**  
Install Basket Curb Inlet Protection As Soon As Inlet Boxes Are Installed (New Development) Or Prior To Land Disturbing Activities (Existing Development).

If Necessary, Adapt Basket Dimensions To Fit Inlet Box Dimensions.

Remove The Grate And Install The Frame Into The Grate Opening. Cut And Install Geotextile Fabric According To The Manufacturer's Recommendations. Replace The Grate.

**Maintenance:**  
Inspect Daily And After Each Storm And Remove Sediment. Replace Or Clean Geotextile Fabric As Needed. Remove Tracked On Sediment From The Street (But Not By Flushing With Water) To Reduce The Sediment Load On This Curb Inlet Practice.

**BASKET CURB INLET PROTECTION**  
Not To Scale

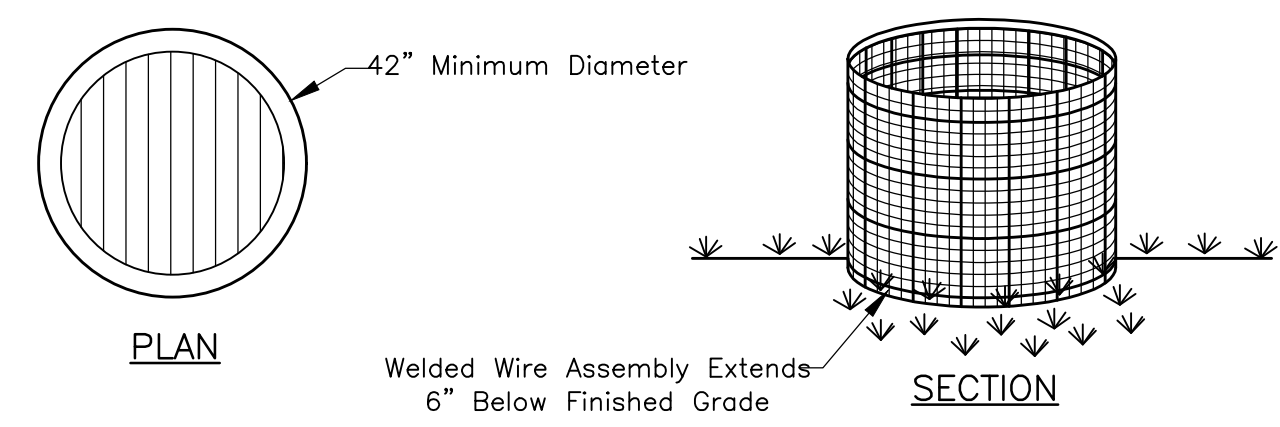

**NOTES:**

**Installation:**  
6" x 6" Welded Wire Mesh Shall Be Formed Of 10Ga. Steel Conforming To ASTM A-185.

Geotextile Shall Be Wrapped Three Inches Over The Top Member Of The 6" x 6" Welded Wire Mesh And Shall Be Secured With Fastening Rings Through Both Geotextile Layers And Close Around A Steel Member At Six Inches On Center. Fastening Rings Shall Be Constructed Of Wire Conforming To ASTM A-641, A-809, A-370, And A-938.

Geotextile Shall Be Secured To The Sides Of Welded Wire Mesh With Fastening Rings At A Spacing Of One Per Square Foot Except For The Bottom 2-Inches Which Shall Extend Past The Welded Wire And Be Left Unsecured For Entrenchment.

Welded Wire Assembly Shall Be Formed Into A Minimum 42" Diameter Circle With A 3" Minimum Overlap On The Ends Secured By Wire Or Zip Ties.

Welded Wire Assembly Shall Then Be Placed In A 6" Deep Trench And Backfilled And Compacted Over The Geotextile Flap.

**Maintenance:**  
Inspect The Welded Wire Inlet Protector Weekly And After Each Rainfall Event.

If Geotextile Tears, Start To Decompose, Or In Any Way Becomes Ineffective, Replace The Affected Portion Immediately.

Remove The Deposited Sediment When It Reaches Half The Height Of The Structure At Its Lowest Point Or Is Causing The Structure To Shift. Take Care To Avoid Undermining The Structure During Clean Out.

After The Contributing Drainage Area Has Been Stabilized, Remove The Structure And Sediment Deposits, Bring The Disturbed Area To Grade, And Stabilize.

**WELDED WIRE INLET PROTECTION**  
Not To Scale

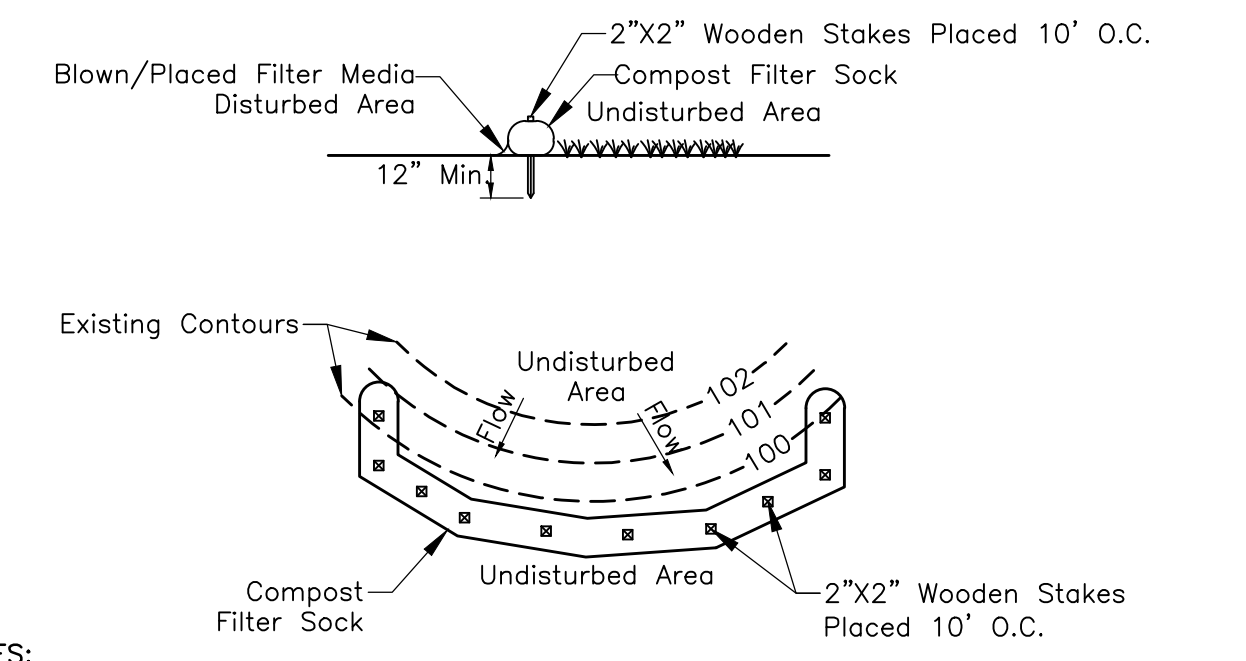

**NOTES:**

**Installation:**  
Filter Sock Should Maintain Solid Contact With The Soil And Be Installed In A Manner That Minimizes Gaps Between The Bottom Of The Sock And The Underlying Substrate.

Filter Socks Should Be Installed Parallel To The Contour With Both Ends Of The Sock Extended Upslope At A 45 Degree Angle To The Rest Of The Sock.

Socks Placed On Earthen Slopes Should Be Staked In The Center Of The Sock Or Immediately Downslope Of The Sock At The Interval Recommended By The Manufacturer. Socks Installed On Paved Surfaces Shall Have Concrete Blocks Placed Immediately Downslope Of The Sock At An Interval Recommended By The Manufacturer.

**Maintenance:**  
Traffic Shall Not Be Permitted To Cross Filter Socks.

Inspect The Structure Weekly And After Each Rainfall Event. Damaged Socks Shall Be Repaired According To The Manufacturer's Specifications Or Replaced Within 24 Hours Of Inspection.

Remove Deposited Sediment When It Reaches Half The Height Of The Filter Sock At Its Lowest Point.

Take Care To Avoid Undermining The Filter Sock During Clean Out.

After The Contributing Drainage Area Has Been Stabilized, Remove And Properly Dispose Of Any Unstable Sediment And Construction Material, And Stabilize.

**FILTER SOCK**  
Not To Scale

**DEVELOPMENT STANDARD - DETAIL DS-E01**

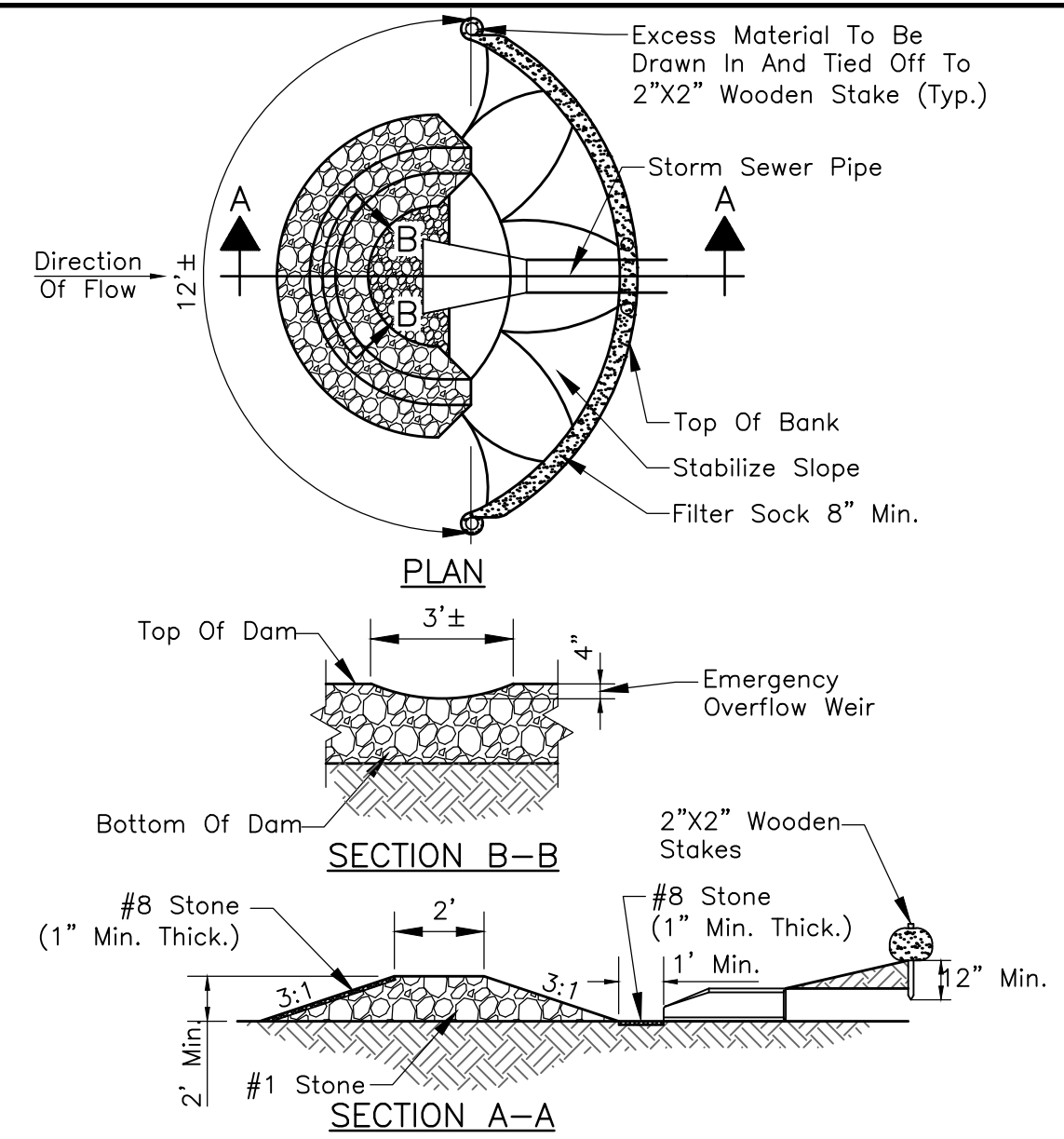

**NOTES:**

**Installation:**  
Foundation Shall Be Laid On Geotextile Fabric.

**Maintenance:**  
Inspect The Structure Weekly And After Each Rainfall Event.

After The Contributing Drainage Area Has Been Stabilized, Remove And Properly Dispose Of Any Unstable Sediment And Construction Material, And Stabilize.

**ROCK DONUT**  
Not To Scale

**DEVELOPMENT STANDARD - DETAIL DS-E02**

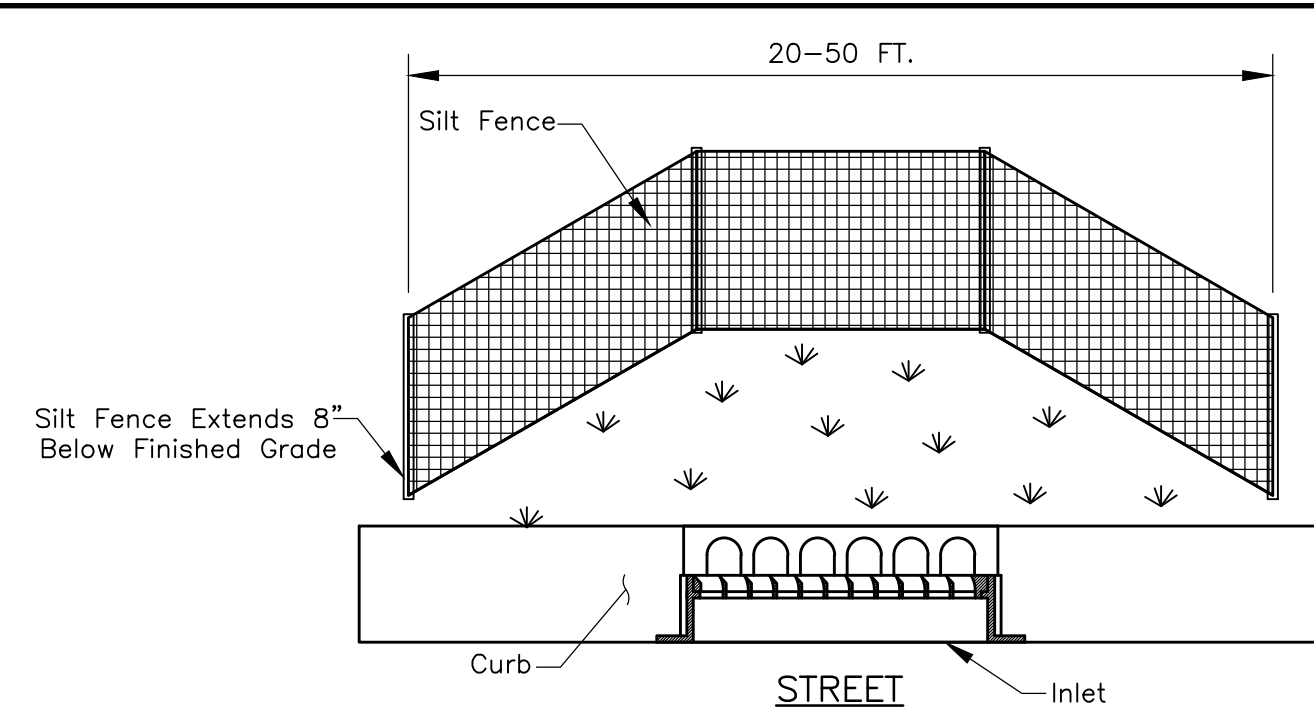

**NOTES:**

**Installation:**  
Silt Fence Is Not Recommended For Use As A Diversion And Should Not Be Used Across A Stream, Channel, Ditch, Swale, Or Anywhere That Concentrated Flow Is Anticipated.

Along The Entire Fence Line, Dig An 8-Inch Deep Flat Bottomed Or V-Shaped Trench. Place Fence According To Manufacturer's Recommendations.

**Maintenance:**  
Inspect The Silt Fence Weekly And After Each 1/2" Rainfall Event.

If Fence Fabric Tears, Starts To Decompose, Or In Any Way Becomes Ineffective, Replace The Affected Portion Immediately.

Remove Deposited Sediment When It Reaches Half The Height Of The Fence At Its Lowest Point Or Is Causing The Fabric To Bulge.

Take Care To Avoid Undermining The Fence During Clean Out.

After The Contributing Drainage Area Has Been Stabilized, Remove The Fence And Sediment Deposits, Bring The Disturbed Area To Grade, And Stabilize.

**SILT FENCE BEHIND CURB**  
Not To Scale

**DEVELOPMENT STANDARD - DETAIL DS-E03**

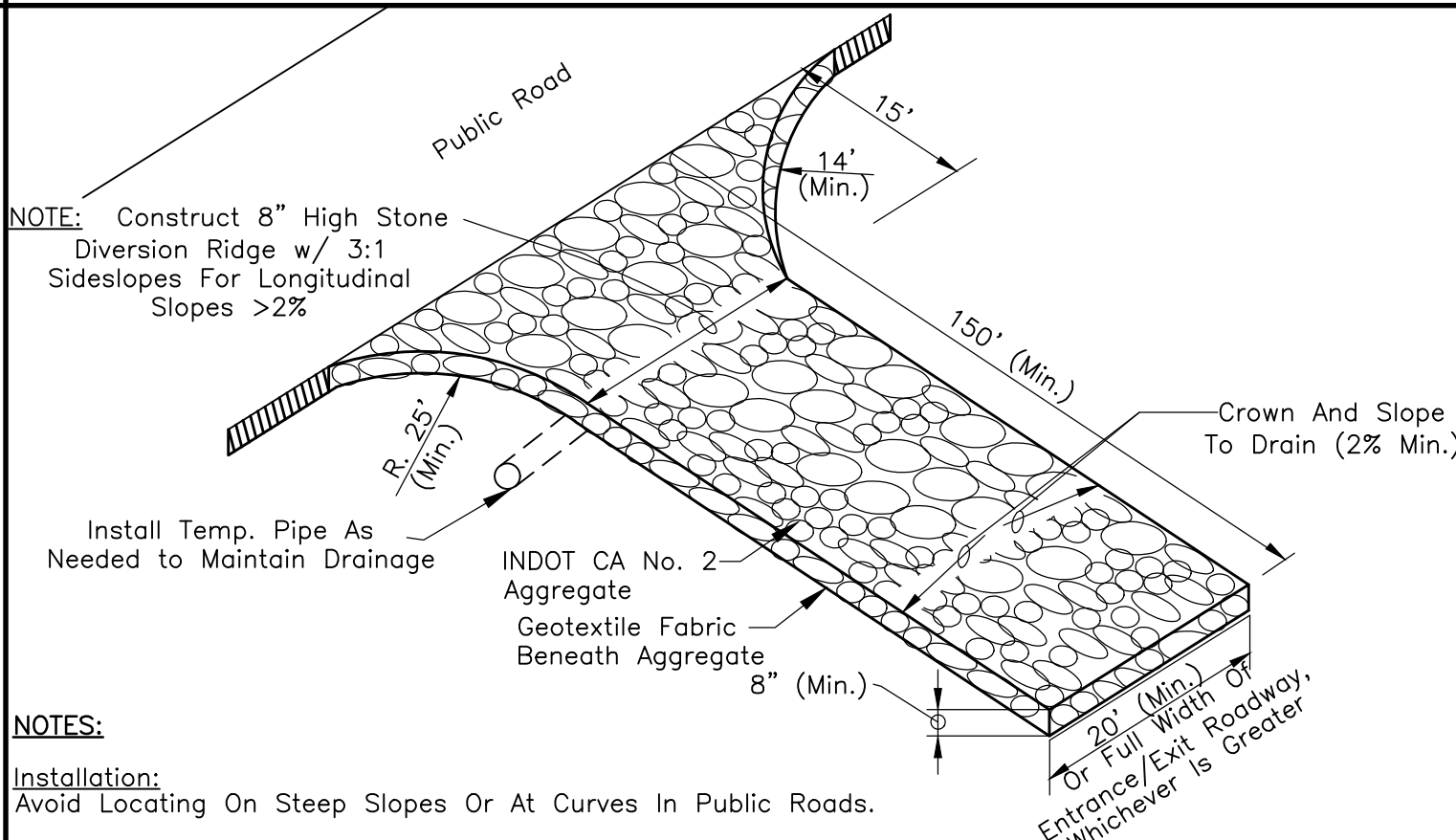

**NOTE:** Construct 8" High Stone Diversion Ridge w/ 3:1 Sideslopes For Longitudinal Slopes >2%

**NOTES:**

**Installation:**  
Avoid Locating On Steep Slopes Or At Curves In Public Roads.

Remove All Vegetation And Other Objectionable Material From The Foundation Area, And Grade The Foundation And Crown For Positive Drainage.

If Longitudinal Slope Is In Excess Of 2%, Construct A Water Bar (Ridge) About 15 Feet From The Entrance To Divert Runoff Away From The Road (See Detail Above).

Install Pipe Under The Pad (If Needed) To Maintain Proper Public Road Drainage.

If Wet Conditions Are Anticipated, Place Geotextile Fabric On The Graded Foundation To Improve Stability.

Place Aggregate To Dimensions And Grade Shown On The Erosion Control Plan, Leaving The Surface Smooth And Sloped For Drainage.

Divert All Surface Runoff And Drainage From The Stone Pad To A Sediment Trap Or Basin.

**Maintenance:**  
Inspect Daily And After Each Storm Event Or Heavy Use.

Reshape Pad And Topdress As Needed For Drainage And Runoff Control.

Immediately Remove Mud And Sediment Tracked Or Washed Onto Public Roads By Brushing Or Sweeping. Flushing Should Only Be Used If The Water Is Conveyed Into A Sediment Trap Or Basin.

**TEMPORARY GRAVEL CONSTRUCTION ENTRANCE**  
Not To Scale

**DEVELOPMENT STANDARD - DETAIL DS-E04**

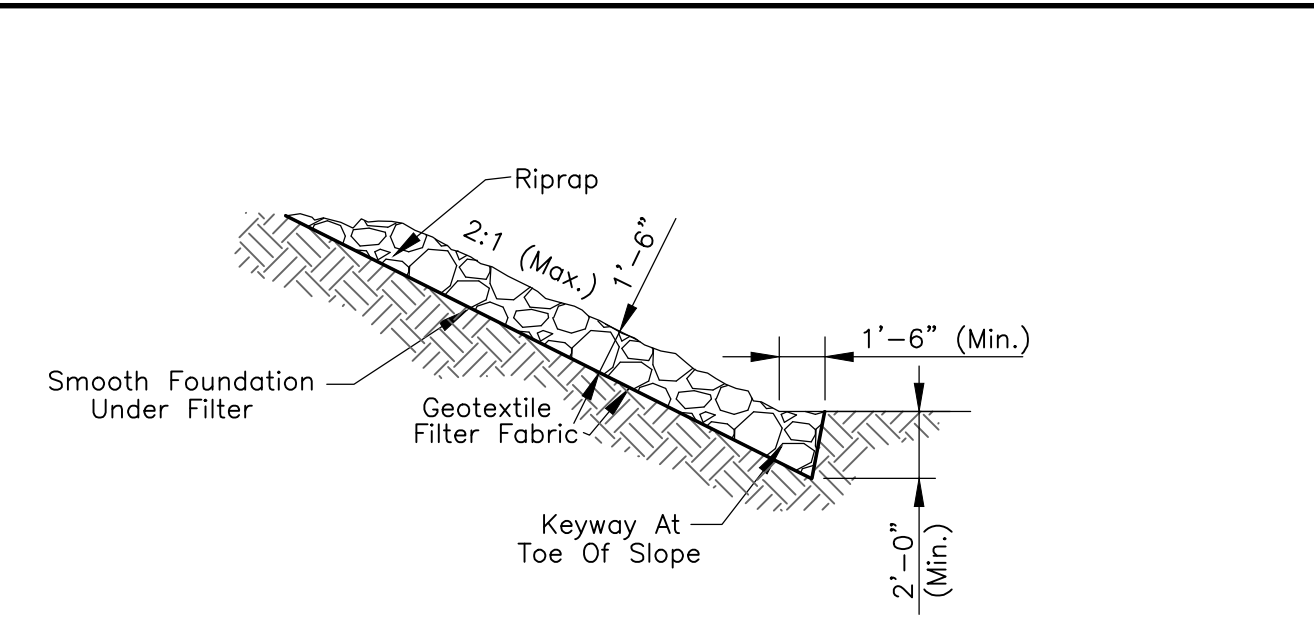

**NOTES:**

**Installation:**  
Excavate Only Deep Enough For Both Filter And Riprap. Compact Any Fill Material To The Density Of The Surrounding Undisturbed Soil.

Cut A Keyway In Stable Material At The Base Of The Slope To Reinforce The Toe. Keyway Depth Should Be 1 1/2 Times The Design Thickness Of The Riprap, And Should Extend A Horizontal Distance Equal To The Design Thickness.

Place Geotextile Fabric On The Smoothed Foundation, Overlapping The Edges 12 Inches Minimum. Secure With Anchor Pins Spaced Every 3 Feet Along The Overlap.

Immediately After Installing The Filter, Add The Riprap To Full Thickness In One Operation. Do Not Dump Through Chutes Or Use Any Method That Causes Segregation Of Rock Sizes, Or That Will Dislodge Or Damage The Underlying Filter Material.

If Fabric Is Damaged, Remove The Riprap And Repair By Adding Another Layer Of Fabric, Overlapping The Damaged Area By 12 Inches.

Place Smaller Aggregate In Voids To Form A Dense, Uniform, Well Graded Mass. Blend The Riprap Surface Smoothly With The Surrounding Area To Eliminate Protrusions Or Over Falls.

**Maintenance:**  
Inspect Periodically For Displaced Aggregate Material, Slumping And Erosion At Edges, Especially Downstream Or Downslope.

**RIPRAP**  
Not To Scale

**DEVELOPMENT STANDARD - DETAIL DS-E05**

**DEVELOPMENT STANDARD - DETAIL DS-E06**

**DEVELOPMENT STANDARD - DETAIL DS-E07**

**DEVELOPMENT STANDARD - DETAIL DS-E08**

REVISIONS		
Rev. No.	Description	Date

RECOMMENDED FOR APPROVAL: *David Lahey* DESIGN ENGINEER 01/01/2019 DATE

APPROVED: *David Lahey* TOWN ENGINEER 01/01/2019 DATE

APPROVED: *Sharon Swan* MS4 OPERATOR 11/19 DATE

TOWN OF PLAINFIELD

EROSION CONTROL (E) DEVELOPMENT STANDARDS

SHEET 20 OF 25

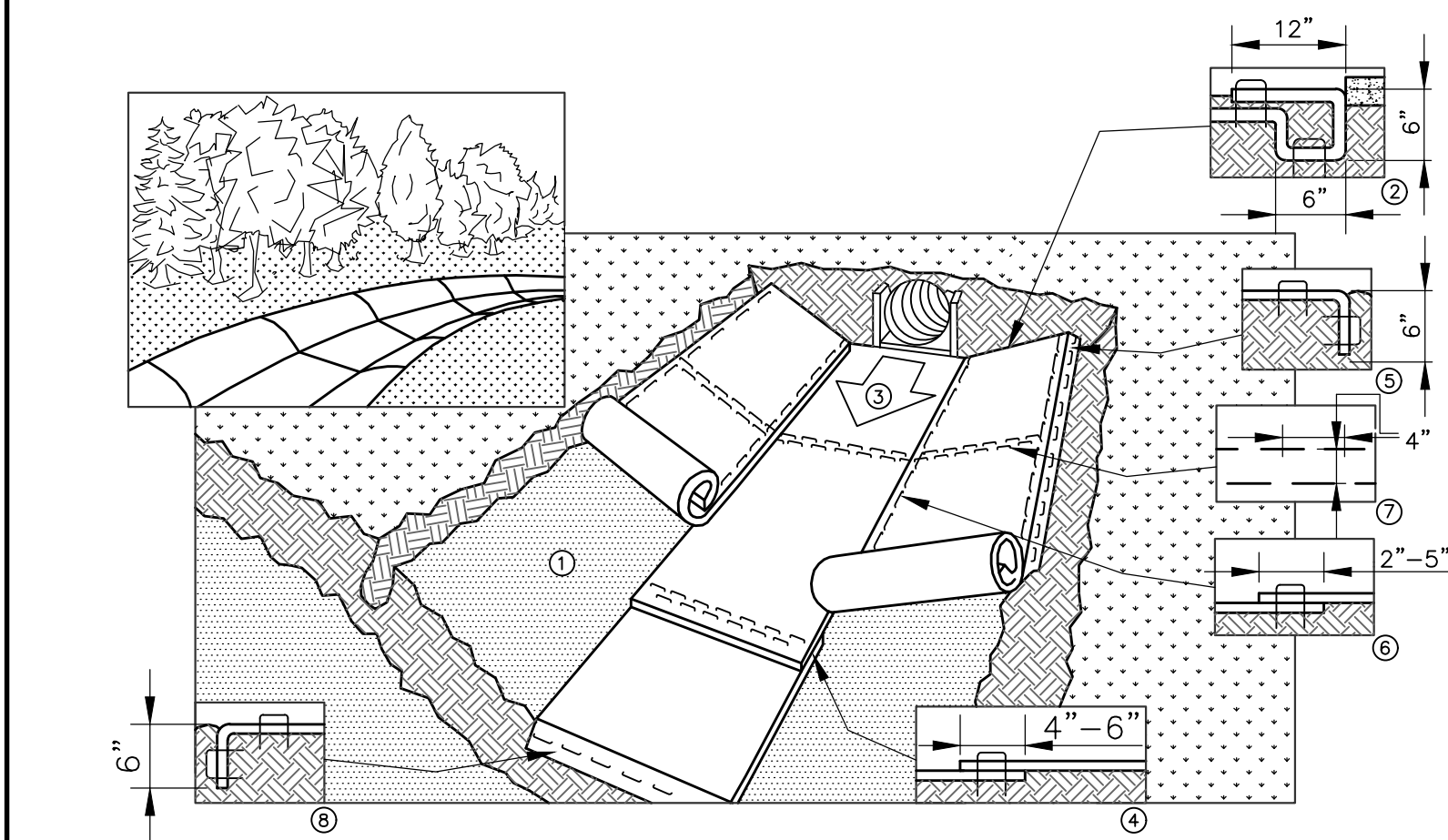

- 1) Prepare Soil Before Installing Blankets, Including Any Necessary Application Of Lime, Fertilizer, Or Seed.
- 2) Begin At The Top Of The Channel By Anchoring The Blanket In A 6 Inch Deep By 6 Inch Wide Trench With Approximately 12 Inches Of Blanket Extended Beyond The Upslope Portion Of The Trench. Anchor The Blanket With A Row Of Staples/Stakes Approximately 12 Inches Apart In The Bottom Of The Trench. Backfill And Compact The Trench After Stapling. Apply Seed To Compacted Soil And Fold Remaining 12 Inch Portion Of Blanket Back Over Seed And Compacted Soil. Secure Blanket Over Compacted Soil With A Row Of Staples/Stakes Spaced Approximately 12 Inches Apart Across The Width Of The Blanket.
- 3) Roll Center Blanket In Direction Of Water Flow In Bottom Of Channel. Blankets Will Unroll With Appropriate Side Against The Soil Surface. All Blankets Must Be Securely Fastened To Soil Surface By Placing Staples/Stakes In Appropriate Locations As Shown In The Staple Pattern Guide. When Using Optional Dot System, Staples/Stakes Should Be Placed Through Each Of The Colored Dots Corresponding To The Appropriate Staple Pattern.
- 4) Place Consecutive Blankets End Over End (Shingle Style) With A 4-6 Inch Overlap. Use A Double Row Of Staples Staggered 4 Inches Apart And 4 Inches On Center To Secure Blankets.

**EROSION CONTROL BLANKET – FLOWLINE APPLICATION**  
Not To Scale

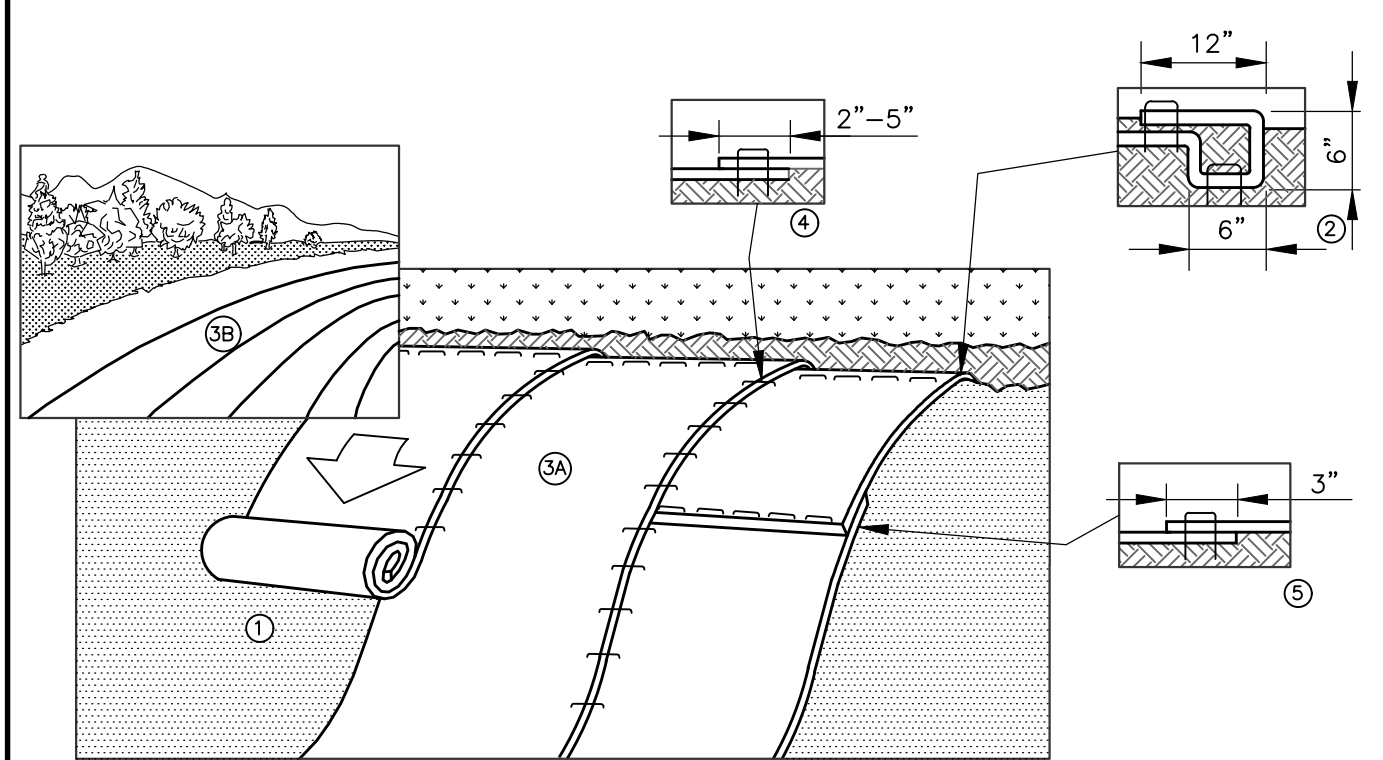

- 1) Prepare Soil Before Installing Blankets, Including Any Necessary Application Of Lime, Fertilizer, And Seed.
- 2) Begin At The Top Of The Slope By Anchoring The Blanket In A 6 Inch Deep By 6 Inch Wide Trench With Approximately 12 Inches Of Blanket Extended Beyond The Upslope Portion Of The Trench. Anchor The Blanket With A Row Of Staples/Stakes Approximately 12 Inches Apart In The Bottom Of The Trench. Backfill And Compact The Trench After Stapling. Apply Seed To Compacted Soil And Fold Remaining 12 Inch Portion Of Blanket Back Over Seed And Compacted Soil. Secure Blanket Over Compacted Soil With A Row Of Staples/Stakes Spaced Approximately 12 Inches Apart Across The Width Of The Blanket.
- 3) Roll The Blankets (A.) Down Or (B.) Horizontally Across The Slope. Blankets Will Unroll With Appropriate Side Against The Soil Surface. All Blankets Must Be Securely Fastened To Soil Surface By Placing Staples/Stakes In Appropriate Locations As Shown In The Staple Pattern Guide. When Using Optional Dot System, Staples/Stakes Should Be Placed Through Each Of The Colored Dots Corresponding To The Appropriate Staple Pattern.
- 4) The Edges Of Parallel Blankets Must Be Stapled With Approximately 2-5 Inches Overlap Depending On Blanket Type. To Ensure Proper Seam Alignment, Place The Edge Of The Overlapping Blanket (Blanket Being Installed On Top) Even With The Colored Seam Stitch On The Previously Installed Blanket.

Consecutive Blankets Spliced Down The Slope Must Be Placed End Over End (Shingle Style) With An Approximate 3 Inch Overlap. Staple Through Overlapped Area, Approximately 12 Inches Apart Across Entire Blanket Width.

Overlap The Blankets With The Direction Of The Flow Of The Water  
NOTE:  
\* In Loose Soil Conditions, The Use Of Staple Or Stake Lengths Greater Than 6 Inches May Be Necessary To Properly Secure The Blankets.

**EROSION CONTROL BLANKET – SLOPE APPLICATION**  
Not To Scale

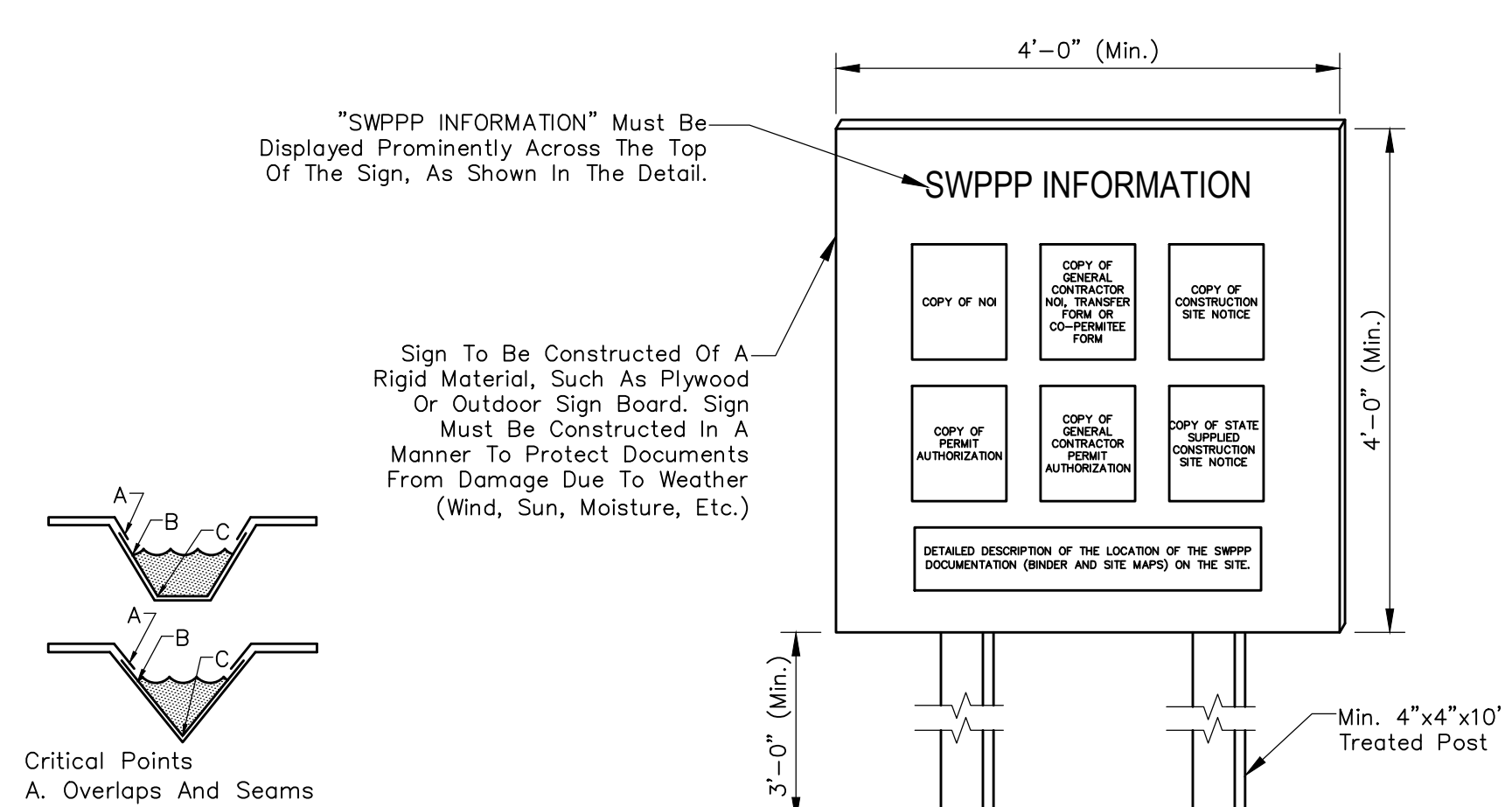

"SWPPP INFORMATION" Must Be Displayed Prominently Across The Top Of The Sign, As Shown In The Detail.

Sign To Be Constructed Of A Rigid Material, Such As Plywood Or Outdoor Sign Board. Sign Must Be Constructed In A Manner To Protect Documents From Damage Due To Weather (Wind, Sun, Moisture, Etc.)

Critical Points  
A. Overlaps And Seams  
B. Projected Water Line  
C. Channel Bottom/Side Slope Vertices

**SWPPP INFORMATION SIGN**  
Not To Scale

- NOTES:**
- 1.) The SWPPP Information Sign Must Be Located Near The Construction Entrance Of This Site, Such That It Is Accessible And Viewable By The General Public, But Not Obstructing Views As To Cause A Safety Hazard.
  - 2.) All Posted Documents Must Be Maintained In A Clearly Readable Condition At All Times Throughout Construction And Until The Notice-Of-Termination (NOT) Is Filed For The Permit.
  - 3.) Contractor Shall Post Other Storm Water And/Or Erosion And Sediment Control Related Permits On The Sign As Required.
  - 4.) Sign Shall Be Located Outside Of Public Right-Of-Way And Easements Unless Approved By The Plainfield MS4 Operator.

**SEEDING:**  
The Following Table Is For General Seeding Information Only. Consult The *Indiana Storm Water Quality Manual* For Recommendations Relating To Steep Banks And Cuts, High Maintenance Areas, And Channels And Areas Of Concentrated Flow.

**SEEDS:**  
40 Percent Kentucky Bluegrass  
40 Percent Creeping Red Fescue  
20 Percent Annual Rye Grass

**FERTILIZER:**  
Commercial Fertilizer (12-12-12)

**STRAW:**  
Clean And Free Of Weed Seeds

Spread Fertilizer Uniformly Over Finish Graded Surfaces At A Rate Of 20 Pounds Per 1,000 Square Feet. Thoroughly Disk, Harrow, Or Rake Fertilizer Into Soil To Depth Not Less Than 2 Inches.

Distribute Seed Mix Same Day As Fertilizer Is Applied. Spread Evenly At A Rate Of 3 Pounds Per 1,000 Square Feet. Rake Lightly And Compact Areas With 100 Pound Roller.

Cover Areas With Straw Evenly Spread At A Rate Of 2 Tons Per Acre Immediately After Seeding. Water Areas With Fine Spray. Do Not Flood Or Create Washes. Protect Seeded Areas From Erosion.

Continue Watering Of These Areas On A Daily Basis For The Remainder Of The Construction Period.

Hold Sloped Areas Steeper Than 2 (Horizontal) To 1 (Vertical) With Wire Mesh Or Stakes And Wire.

	JAN	FEB	MAR	APR	MAY	JUN	JUL	AUG	SEP	OCT	NOV	DEC
<b>Temporary Seeding Dates</b>												
Wheat Or Rye												
Oats												
Annual Rye Grass												
<b>Permanent Seeding Dates</b>												
Non-Irrigated*												
Irrigated												
Dormant Seeding**												

■ Irrigation Required  
\* Seeding Dates May Be Extended 5 Days If Mulch Applied And Planted Late Summer  
\*\* Increase Seeding Rate By 50%

**NOTES:**  
If Construction Activities Take Place During The Months Of November Through February, Use Dormant Seeding Practices In Place Of Temporary And Permanent Seeding Practices.  
See Chapter 7 Of The *Indiana Storm Water Quality Manual* For Additional Seeding Recommendations.

REVISIONS		
Rev. No.	Description	Date

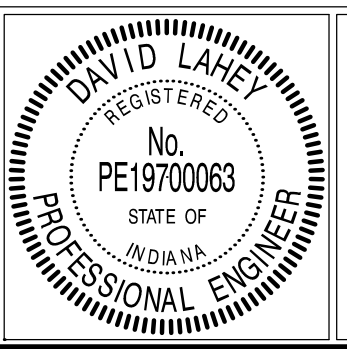

RECOMMENDED FOR APPROVAL: *[Signature]* 01/01/2019 DATE  
DESIGN ENGINEER  
APPROVED: *[Signature]* 01/01/2019 DATE  
TOWN ENGINEER  
APPROVED: *[Signature]* 11/17/19 DATE  
MS4 OPERATOR

**EROSION CONTROL NOTES**

**GENERAL:**  
Take Measures To Control Erosion And Sedimentation To Assure That Sediment Is Not Transported From The Site By Storm Events. Practices Such As Silt Traps Or Filters Shall Be Installed Prior To Land Disturbing Activities. New Drainage Swales Shall Be Seeded And/Or Sodded, Or Other Protective Practices Applied, Immediately Following Construction. All Practices Shall Be Maintained To Remove Sediment From Runoff Leaving The Site As Long As Unstabilized Soil Conditions Exist.

After Land Disturbing Activities Cease And The Soil Is Stabilized, Temporary Erosion Control Measures May Be Eliminated If Their Purpose Has Been Fulfilled. Any Disturbed Soil Resulting From Removal Of Such Practices Shall Be Stabilized By Approved Methods.

Dispose Properly All Waste And Unused Building Materials Including, But Not Limited To, Garbage, Debris, Cleaning Wastes, Water, Toxic Materials, And Hazardous Substances. Do Not Allow Substances To Be Carried By Runoff Into A Receiving Channel Or Storm Sewer System.

Clean Public Or Private Roadways Daily And After Major Storms Using Acceptable Methods To Remove Any Accumulated Sediment. The Developer's Contractors Are Responsible For Supervision Of The Construction Activity Within The Development And Shall Take All Necessary Actions To Remove Sediment From The Streets.

For Construction Sequence, Maintenance, And Other Soil Erosion Requirements, See Specifications For Site Clearing, Slope Protection, Erosion Control, Landscaping, And Seeding.

Erosion And Sediment Control Practices Must Adhere To, Or Exceed Those Shown On The Erosion Control Plan, (And Rule 5 327 IAC 15-5) And Shall Be In Accordance With The *Indiana Storm Water Quality Manual*, Indiana Department Of Environmental Management.

**SURFACE STABILIZATION:**  
Cut Slopes Which Are To Be Topsoiled Should Be Scarified To A Minimum Depth Of 4 Inches Prior To Placement Of Topsoil. Install Erosion Control Blankets On All Slopes Of 3 (Horizontal) To 1 (Vertical).

Stabilize All Disturbed Ground Left Inactive For Fifteen Or More Days By Seeding, Sodding, Mulching, Or By Other Equivalent Erosion Control Practices. See The Landscape Plan For Permanent Ground Cover Requirements Adjacent To The Building And Parking Areas.

**TEMPORARY GRAVEL CONSTRUCTION ENTRANCE/EXIT PAD:**  
Construct The Temporary Gravel Drive Using 6 Inches INDOT CA No. 2 Stone Over A Stable Foundation. Geotextile Fabric May Be Used Under Wet Conditions Or For Soils Within A High Seasonal Water Table To Provide Greater Bearing Strength. Grade For Positive Drainage.

Inspect The Entrance Pad Area Weekly And After Storm Events Or Heavy Use. Reshape The Pad As Needed For Drainage And Runoff Control. Top Dress Pad With Clean Stone.

**SODDING:**  
Do Not Install Sod On Hot, Dry Soil, Frozen Soil, Compacted Clay, Loose Sand Or Gravel, Or Pesticide Treated Soil. Ideal Sodding Time Is May 1-June 1, Or September 1-October 20, Although It Can Be Installed As Early As March 15, If Available And Temperatures Are Above 32° F, Or June 1-September 1 If Irrigated.

Install Sod After Other Erosion Control Practices Have Been Completed. Break Up Compacted Soils Sufficiently To Create A Favorable Rooting Depth Of 6-8 Inches, Using A Chisel Plow, Disk, Harrow, Or Rake.

Apply Topsoil If The Site Is Otherwise Unsuited For Establishing Vegetation. Shape, Smooth, And Firm The Soil Surface.

Have The Soil In The Sod Bed Tested To Determine Its pH And Nutrient Level. If The pH Is Too Acidic For The Grass Sod To Be Installed, Apply Lime According To Test Results Or At The Rate Recommended By The Sod Supplier.

Fertilize As Recommended By The Soil Test. If Testing Was Not Done, Consider Applying 400-600 Lbs./Acre Of 12-12-12 Analysis Fertilizer, Or Equivalent Fertilizer, As Recommended By The Soil Test. Work The Fertilizer Into The Soil To 2-4 Inches Deep.

**TREE CONSERVATION/PROTECTION:**  
Protect Trees From Construction Equipment By Fencing Off An Area Equivalent To The Tree's Crown With Temporary Construction Safety Fence. If A Fence Cannot Be Erected, Cushion The Rooting Area With 6 Inches Of Wood Chips, Or Wood Or Brick Paths.

Create Traffic Patterns Such As To Keep Soil Compaction To A Minimum. Store Supplies And Equipment Away From Protected Tree Areas. Aerate Soil Where Compaction Has Been Excessive.

When Clearing Areas Adjacent To Protected Trees, Use Equipment Such As A Brush Cutter Or Rotary Ax, Or Cut By Hand. Where Root Areas Must Be Graded, Cut Large Roots Instead Of Tearing Them With Equipment.

Minimize Changes In The Drainage Pattern. Avoid Putting Fill Over The Root System.

Prune Low Hanging Limbs That Could Otherwise Be Broken Off By Equipment.

Repair Wounds Simply By Removing Damaged Bark And Wood Tissue (Do Not Use Tree Paint).

**EROSION CONTROL BLANKETS:**  
Use Machine Produced Mat Of Straw Fiber Matrix Or Curled Wood Excelsior Of 80 Percent, 6 Inch Or Longer Fiber Length.

Evenly Distribute Fibers Over Entire Area Of Blanket To Provide Consistent Thickness.

Provide Blanket With Top Side Covered With Biodegradable Extruded Plastic Mesh.

Treat Blankets To Impart Smolder Resistance Without Use Of Chemical Additives.

Provide "Curlex Blankets" By American Excelsior Company, Or "S150" By North American Green, Or Accepted Substitute.

**EROSION CONTROL BLANKET STAPLES:**  
Use Minimum 0.091 Inch Diameter Steel Wire "U" Shape With Legs 6 Inches In Length With 1 Inch Crown.

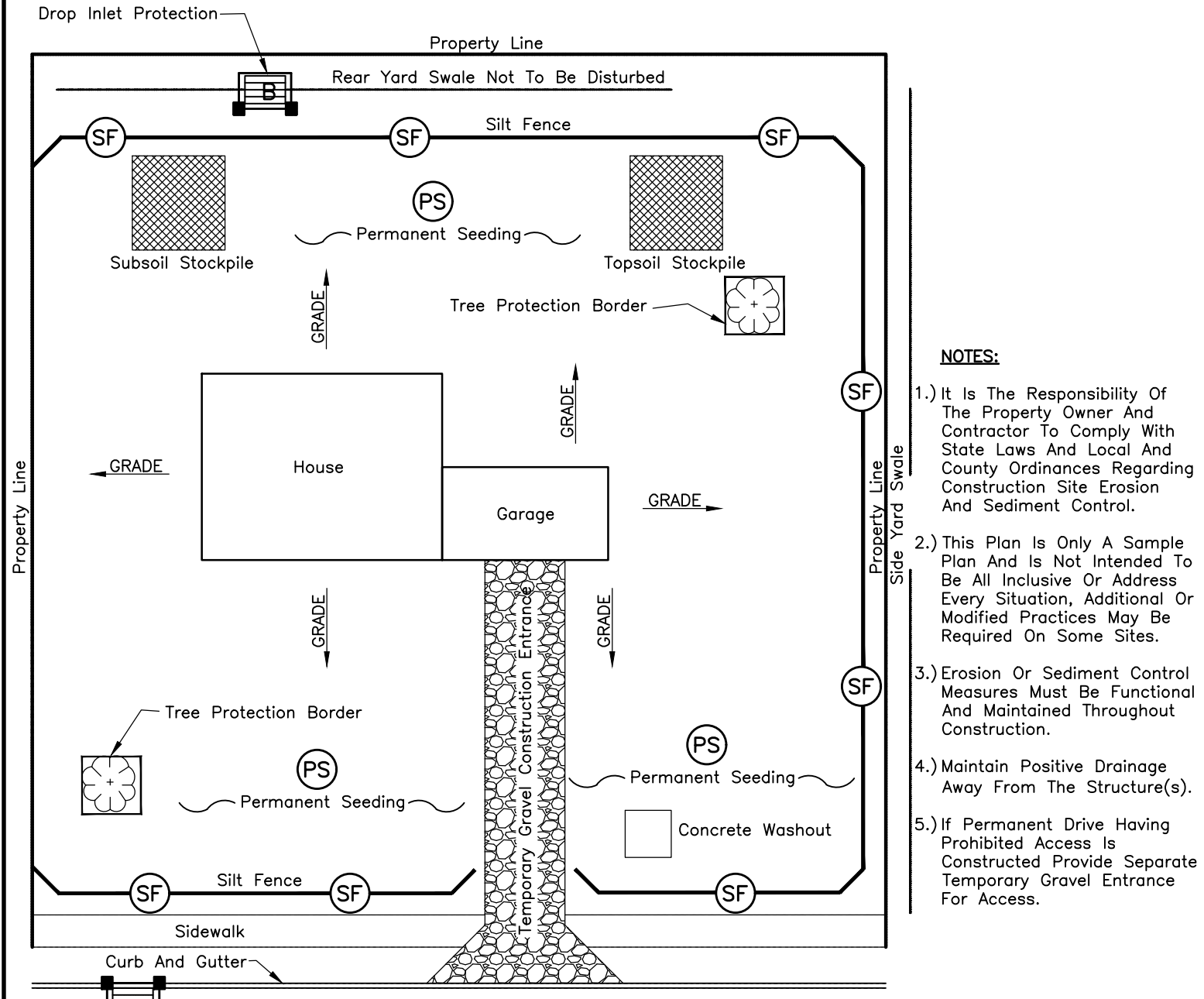

**SAMPLE EROSION CONTROL SITE PLAN**  
Not To Scale  
(For Construction Of Typical Single Family Dwellings.)

**DEVELOPMENT STANDARD – DETAIL DS-E09**

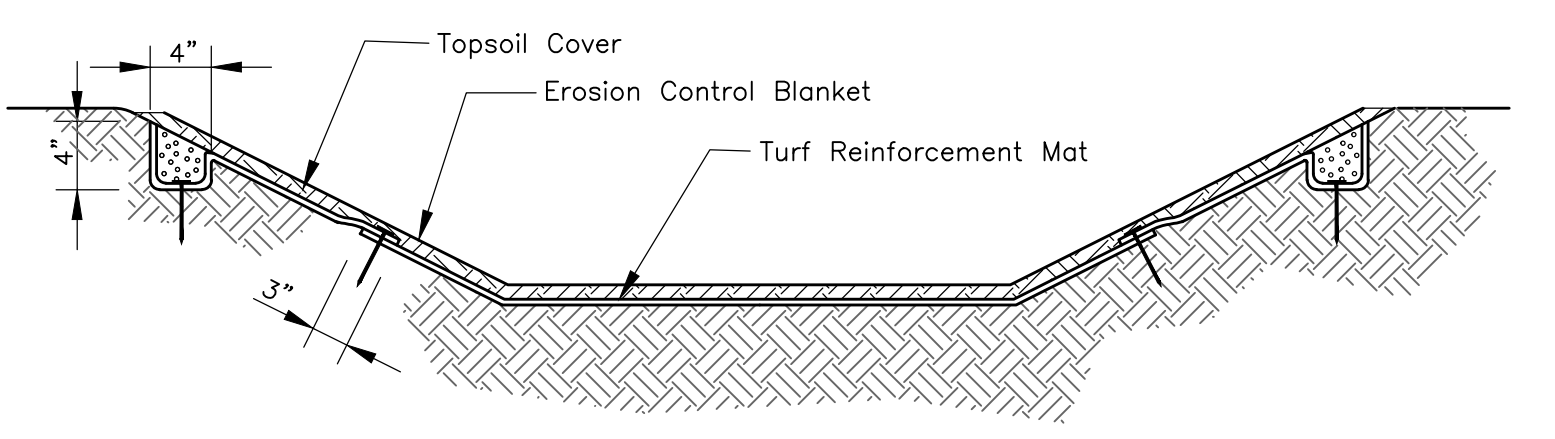

Extend Turf Reinforcement Mat To Accommodate Maximum Designed Flow Depth

**NOTES:**  
**Installation:**  
Select The Type Of Mat Recommended For The Site Conditions (Slope, Channel, Flow Velocity) And Problem To Be Addressed.

Install Any Practices Needed To Control Erosion And Runoff, Such As Temporary Or Permanent Diversions, Slope Drains, Sediment Basins/Traps, Silt Fence Or Straw Bale Dams.

Grade The Site As Specified.

Install The Mat According To Manufacturer's Specifications.

Backfill Topsoil To A Depth Equal To The Thickness Of The Mat.

Seed The Area After The Mat Has Been Installed And Backfilled With Soil. Mulch The Area, Or Use Erosion Control Blankets To Stabilize The Surface.

**Maintenance:**  
Until The Surface Is Stabilized, Inspect Weekly And After Each Storm Event For Erosion Exposing The Mat.

If A Specific Area Shows Erosion, Add Soil And Restabilize.

**TURF REINFORCEMENT MAT**  
Not To Scale

**GENERAL NOTES:**

- 1.) All Appropriate Plainfield Town Standards Apply.
- 2.) All Signs Shall Be High Intensity, High Reflectivity Accordance With The Most Recent M.U.T.C.D.
- 3.) All Roundabout Designs, Signage And Marking Must Be Approved By The Town Of Plainfield.
- 4.) Splitter Islands Shall Be A Minimum 6' In Width For Widths 12' Or Greater Island Opening Shall Be Perpendicular To Cross Walk For Each Direction Of Traffic.

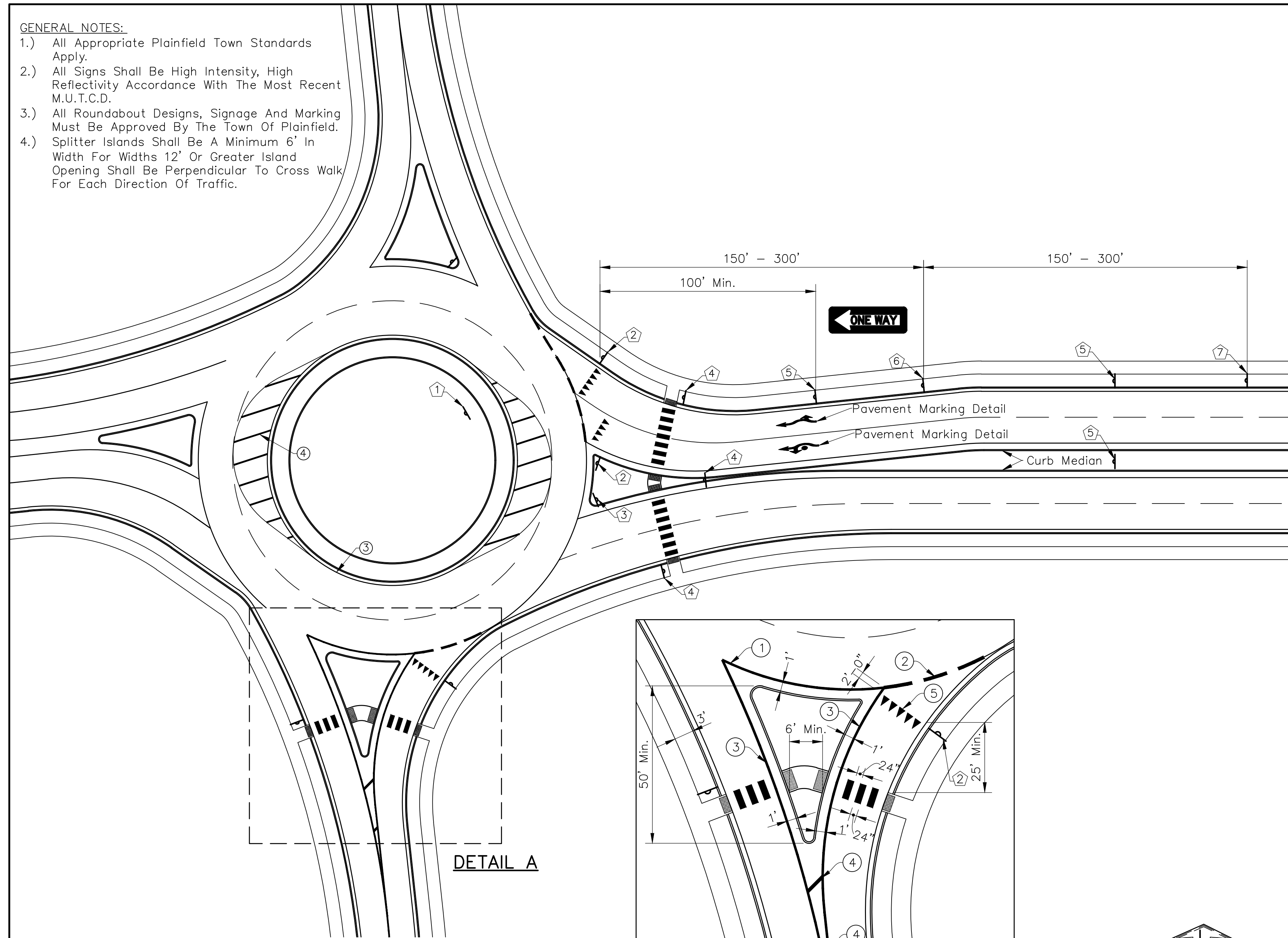

**LOW SPEED URBAN / SUBURBAN ROUNDABOUT DETAIL**  
Scale: 1"=30'

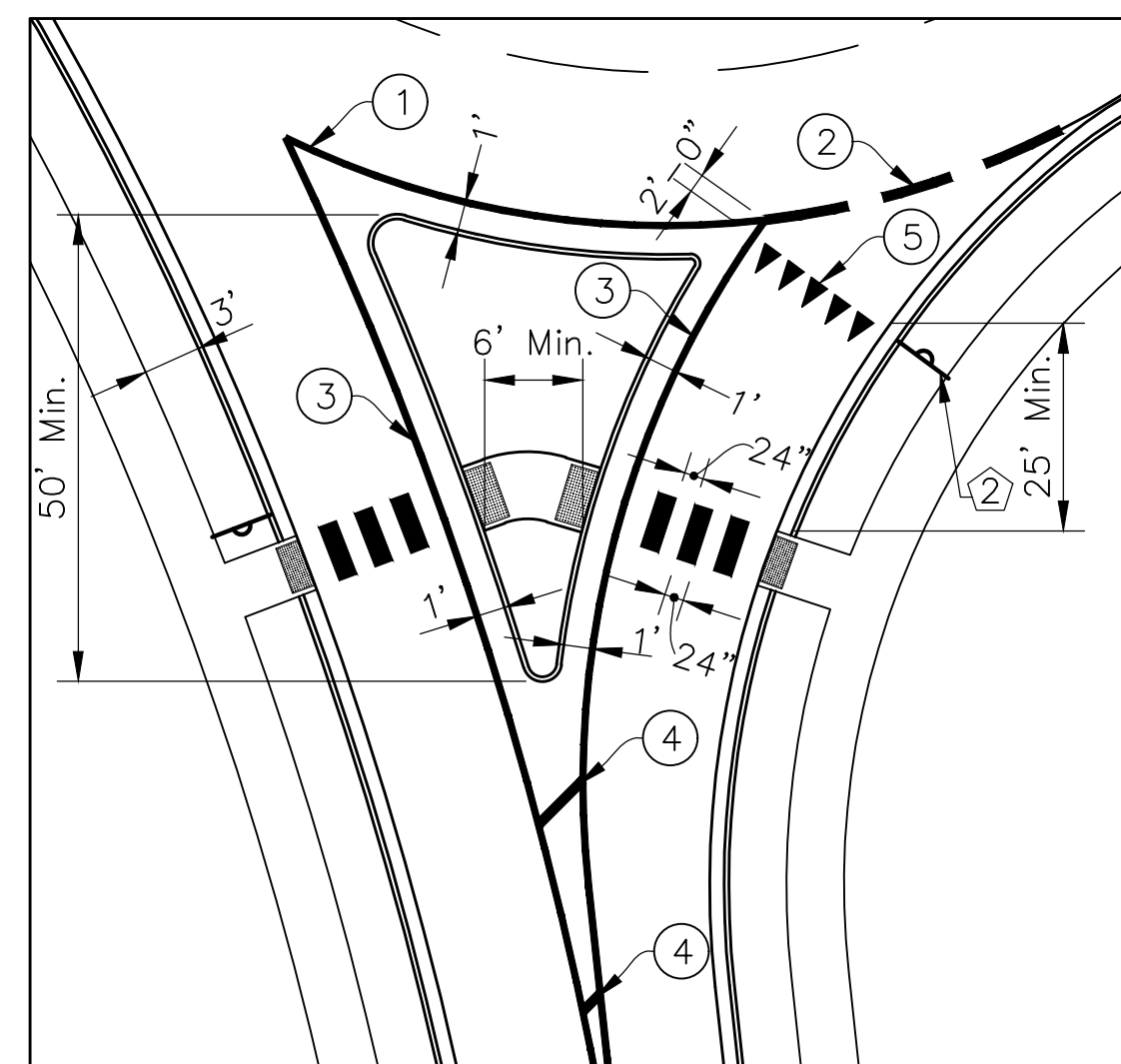

**DETAIL A**  
Scale: 1"=20'

**ST. NAME**

3



TO BOTH LANES

2

R1-2



R6-1R

&  
R6-4a



W11-2A



W16-7P

SIGN ASSEMBLY

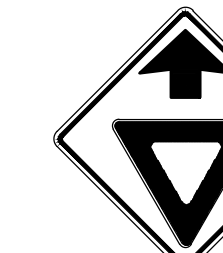

W3-2A

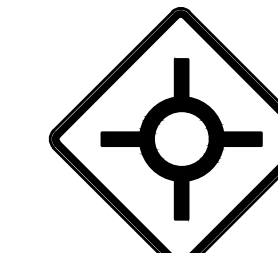

W2-6

**ST. NAME**



W13-1

SIGN ASSEMBLY

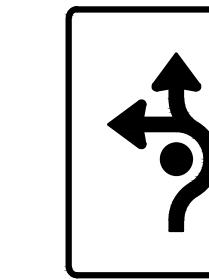

RTA LTE

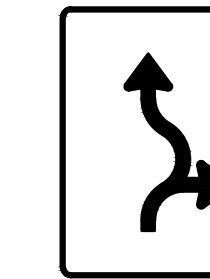

RTA TR

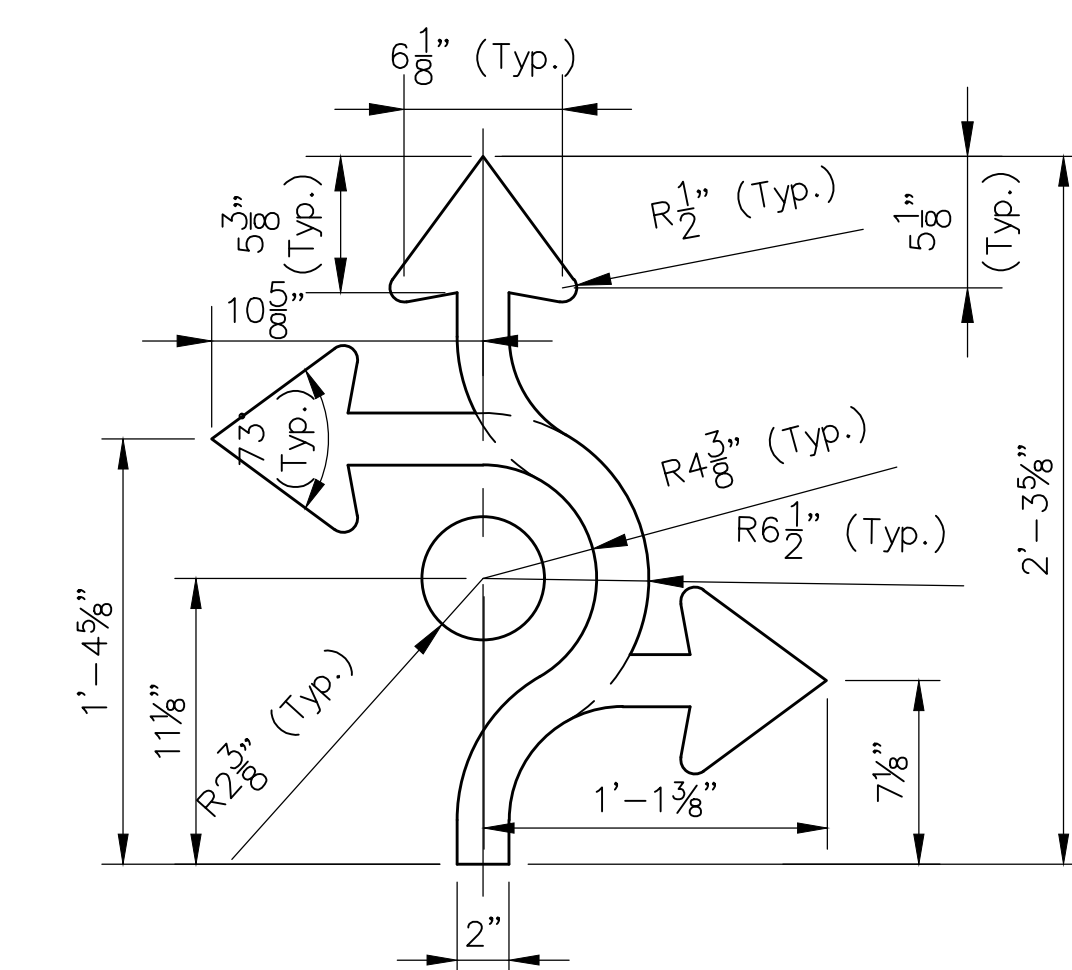

**DETAIL**

**SIGN DETAILS**  
See Post Detail On Sheet 5



**COMPONENT KEY**

The Labeled Areas Above Correspond To The Portions Needed For Each Type Of Roundabout Traffic Arrow.

For Example: The Roundabout Traffic Arrow Type Tr Requires The "Common", "T", "R", And "E" Areas.

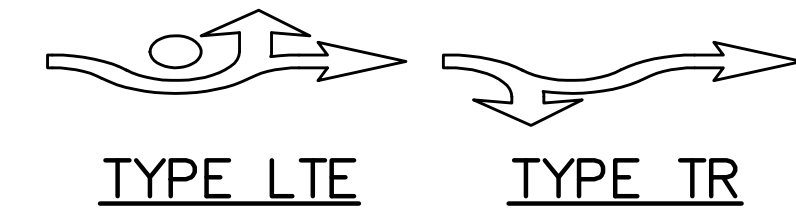

**TYPE LTE TYPE TR MARKING DETAILS**

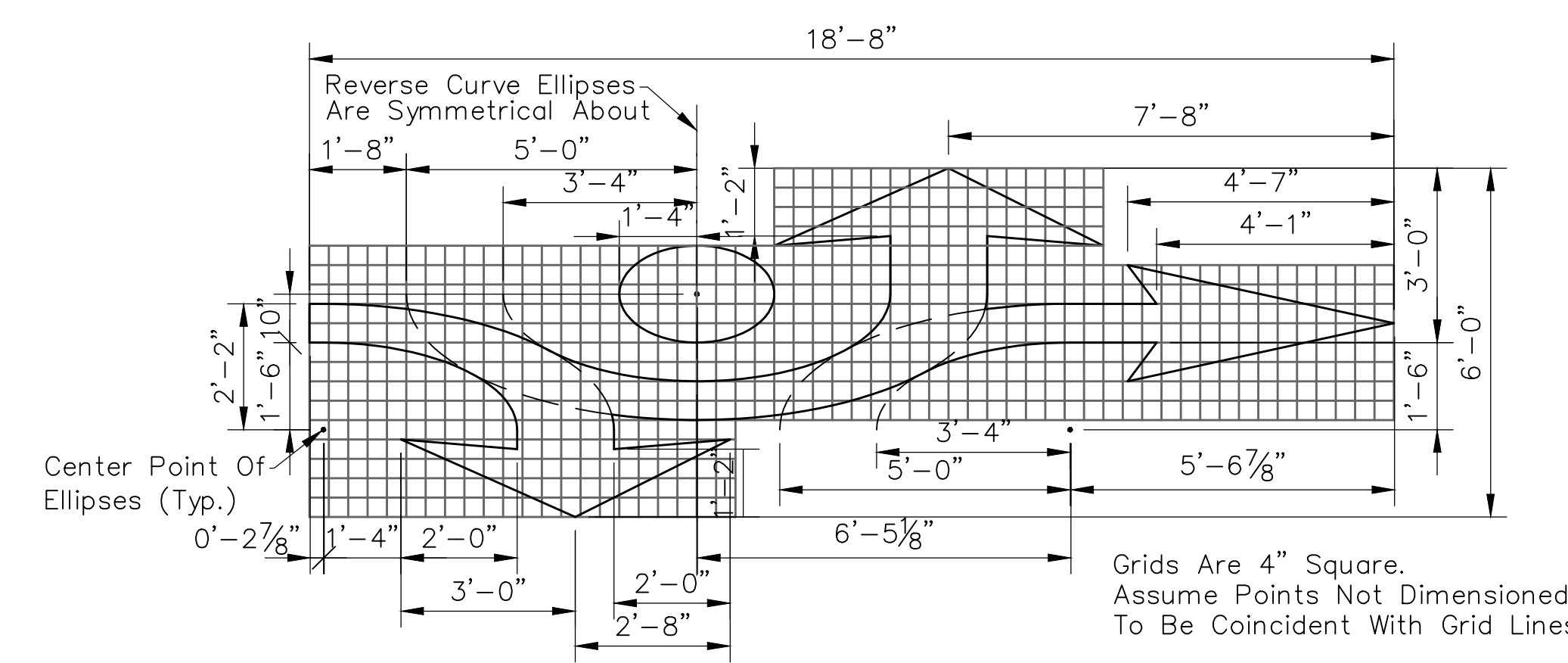

**PAVEMENT MARKING DETAILS**

**DETAIL B**

Grids Are 4" Square. Assume Points Not Dimensioned To Be Coincident With Grid Lines

**LEGEND**

- 1 Line, Solid White, 8"
- 2 Line, Broken White, 8"
- 3 Line, Solid Yellow, 8"
- 4 Crosshatch 45°, Solid Yellow, 12" (20' Spacing)
- 5 Shark Tooth Yield Triangle 2'W x 3'H
- Sign

REVISIONS		
Rev. No.	Description	Date

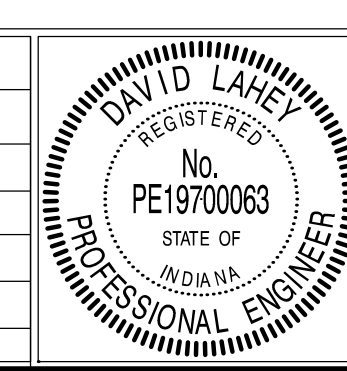

RECOMMENDED FOR APPROVAL: *David Laney* DESIGN ENGINEER 01/01/2019 DATE

APPROVED: *Samuel...* TOWN ENGINEER 01/01/2019 DATE

APPROVED: *Jared...* DIRECTOR OF TRANSPORTATION 01/01/2019 DATE

TOWN OF PLAINFIELD	SHEET 22
LOW SPEED URBAN / SUBURBAN ROUNDABOUT DETAIL	OF 25

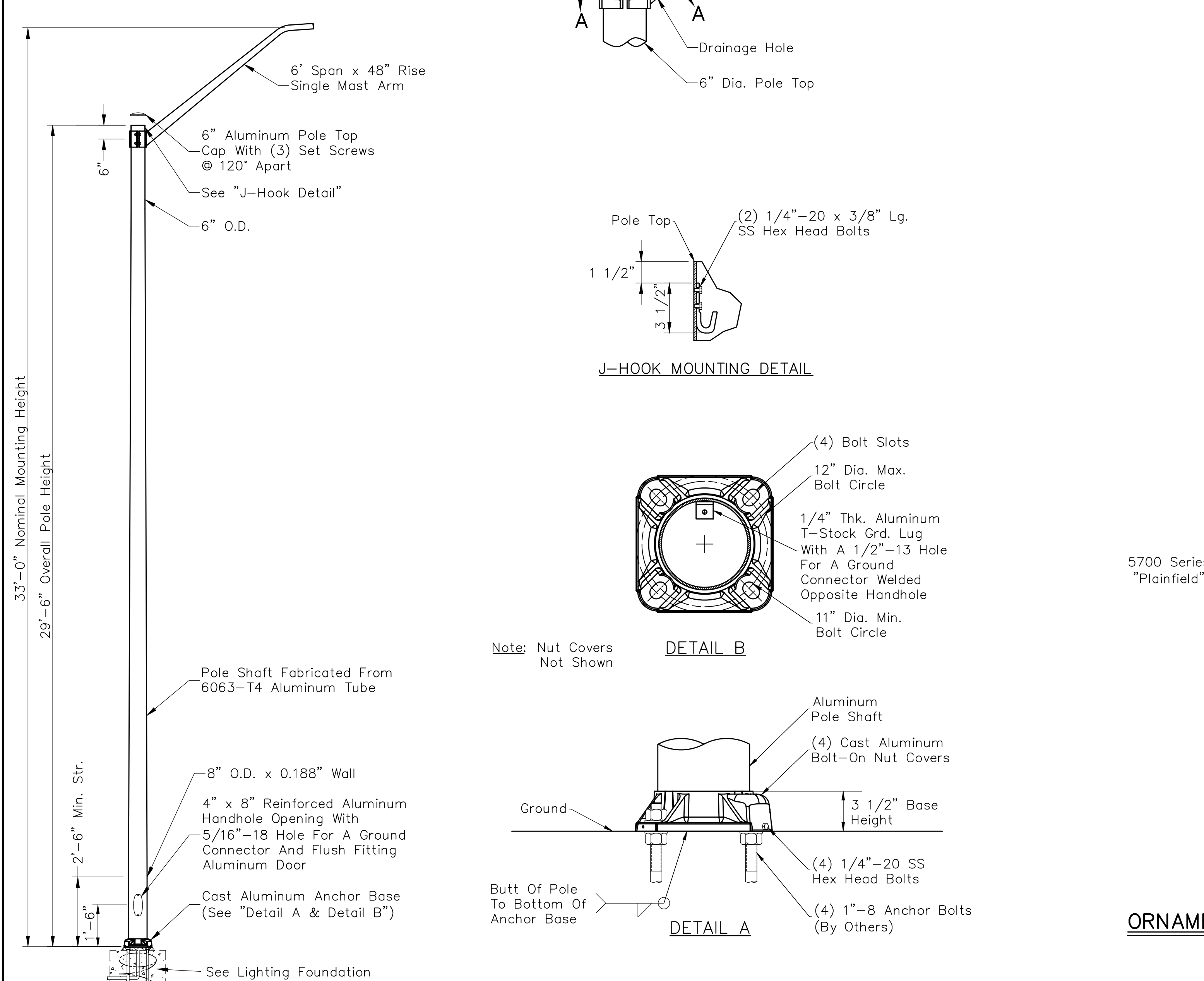
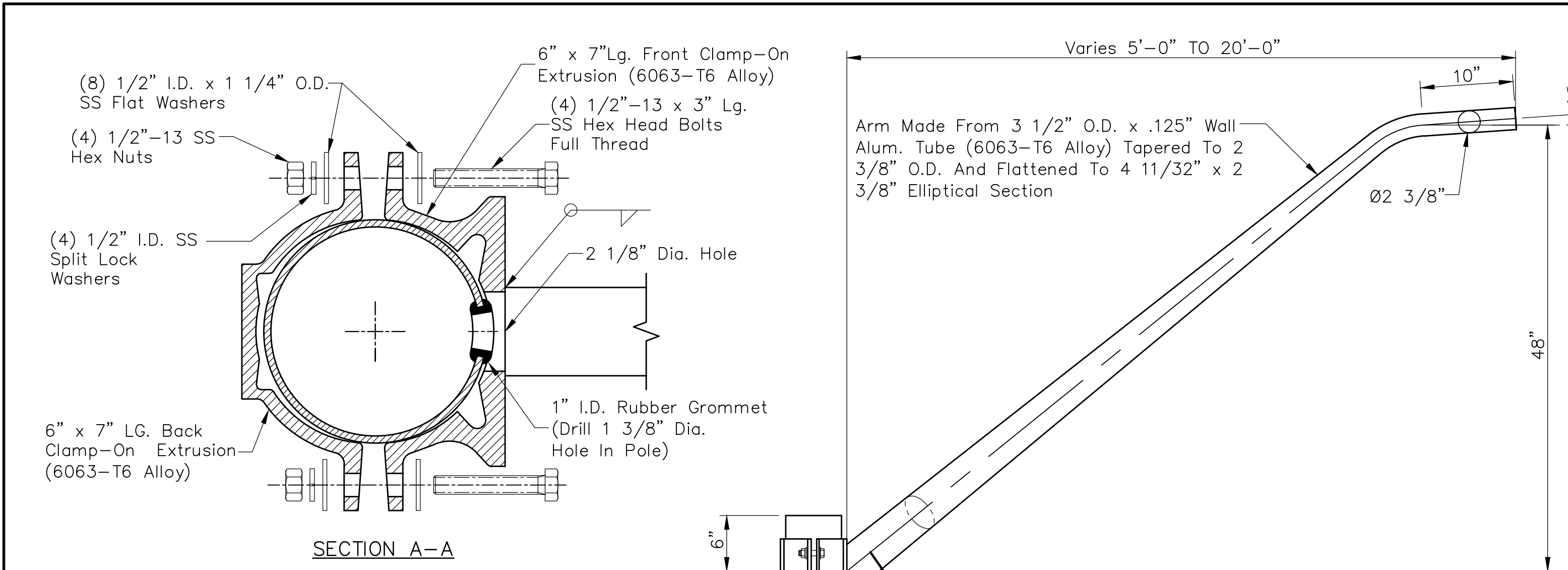

- Lighting Component Notes:**
1. Ornamental Light Poles Shall Be Manufactured By Valmont Electrical MFG. Co.
  2. Standard Light Poles Shall Meet INDOT Design Standards
  3. Pole Shafts Shall Be 16-Sharp Flute Tapered. Base Diameter, Top Diameter, Shaft Length, And Gauge Thickness, 19 Ft. Maximum Vertical Clearance From Top Of Pavement To Bottom Of All Signal Heads.
  4. Base Coat Shall Be Hot Dipped Galvanized To ASTM:A123.
  5. Finish Shall Be TGIC Or Urethane Polyester Powder.
  6. Ornamental Light Pole Color Shall Be Woodland Green (Color Code: RAL 6228).
  7. Structural Design Is To Be Completed By The Contractor Under The Direct Supervision Of An Experienced Professional Engineer Registered In The State Of Indiana. The Successful Bidder Is To Provide Shop Drawings, Which Bear, For All Structural Components The Professional Seal And Signature Of The Engineer Responsible For The Structural Design.
  8. Prior To Fabrication, Shop Drawings For All Lighting Components Shall Be Submitted To The Engineer For Approval.
  9. Evolve Roadway Scalable Fixture Shall Be The Following: ERS1 Or ERS2 And 4000K Luminaire Head Shall Be Finished To Match Pole. Color Temperature.
  10. Technical Specification, Photometric Plan, And Visual File Shall Be Submitted To The Town Of Plainfield For Review Prior To Installation.

- Helical Foundation Notes:**
1. Finish: Hot Dip Galvanize Per ASTM-A153 (Latest Revision).
  2. Baseplate To Be Perpendicular To Shaft Axis ( $\pm 1^\circ$ ) And Hole Centerline Concentric ( $\pm .188$ ) To Shaft Axis.
  3. All Material Is To Be New, Unused And Mill Traceable Meeting The Following Specifications:  
 Baseplate: ASTM A36-(Latest Revision) Structural Steel (Conform To AASHTO Tech. Bul. #270).  
 Shaft: ASTM A252-(Latest Revision) Grade 2, Steel Pipe Piles. Alternate Material: ASTM A53-(Latest Revision) Type E Or S, Grade B, Steel Pipe Or ASTM A500-(Latest Revision) Grade B, Structural Steel Tubing.  
 Helix: ASTM A635-(Latest Revision) 3/8" Thick Hot Rolled Steel Plate Or Coil.  
 Pilot Point: ASTM A575-(Latest Revision) 1-1/4" Diameter Hot Rolled Steel Bar. Bolts: Carriage Bolts Per ANSI B-18.5, SAE J429 Grade-5.  
 Nuts: Heavy Hex Nuts Per ASTM A194 Grade 2H Or ASTM A563 Grade DH, Meeting The Supplementary Requirements Of ASTM A563; 1-8UNC-2B Per ANSI B18.2.2.

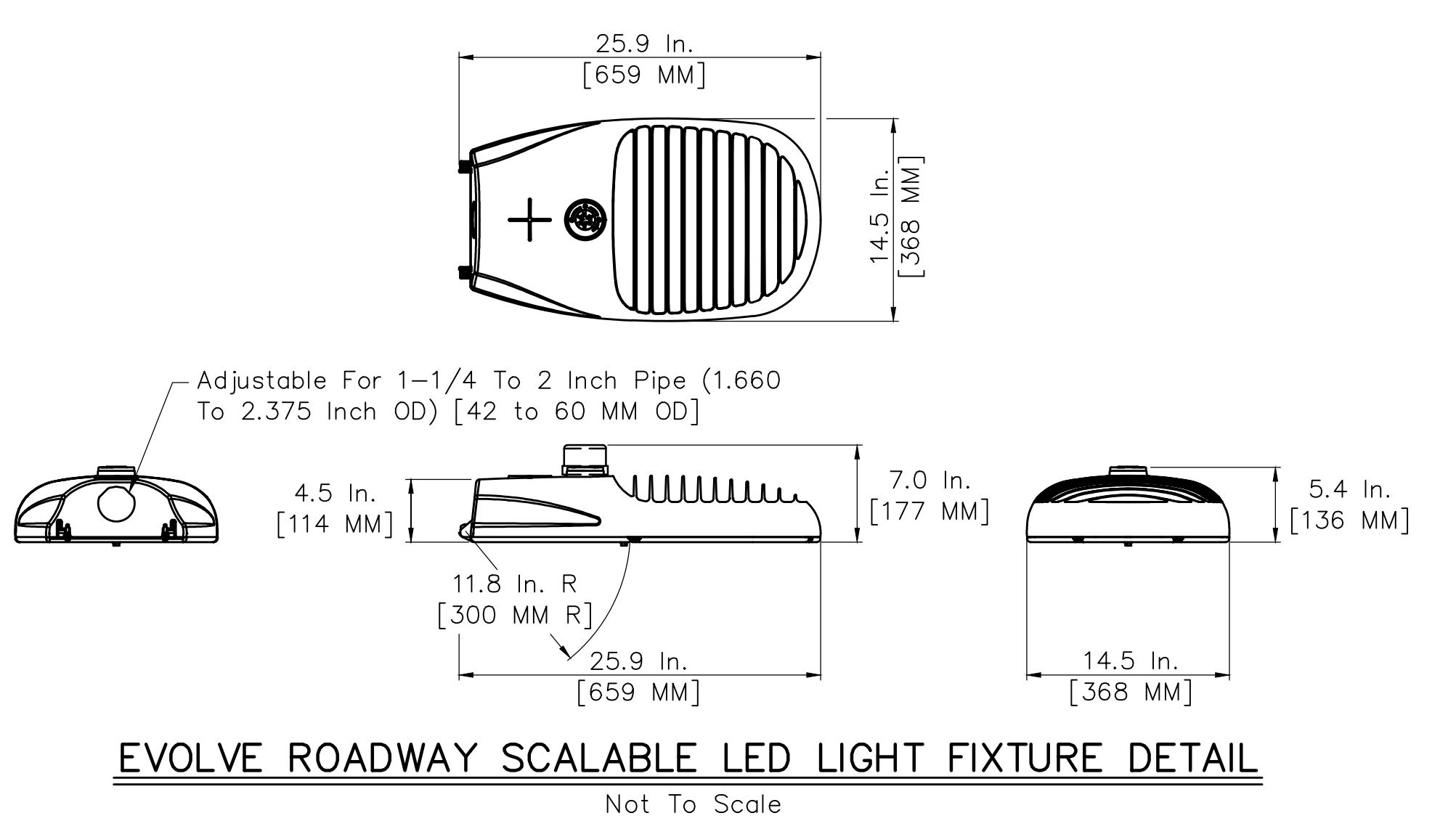
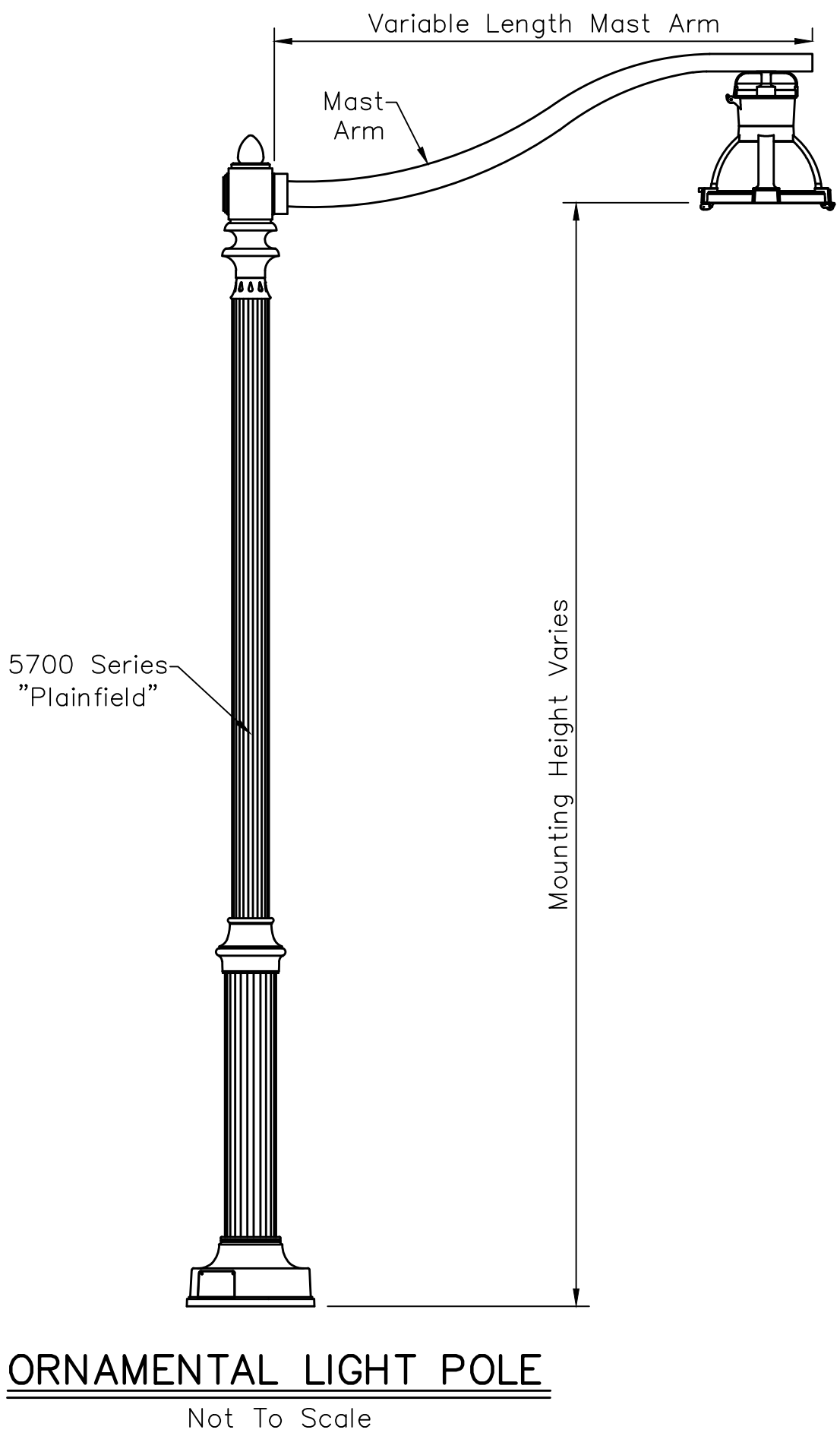
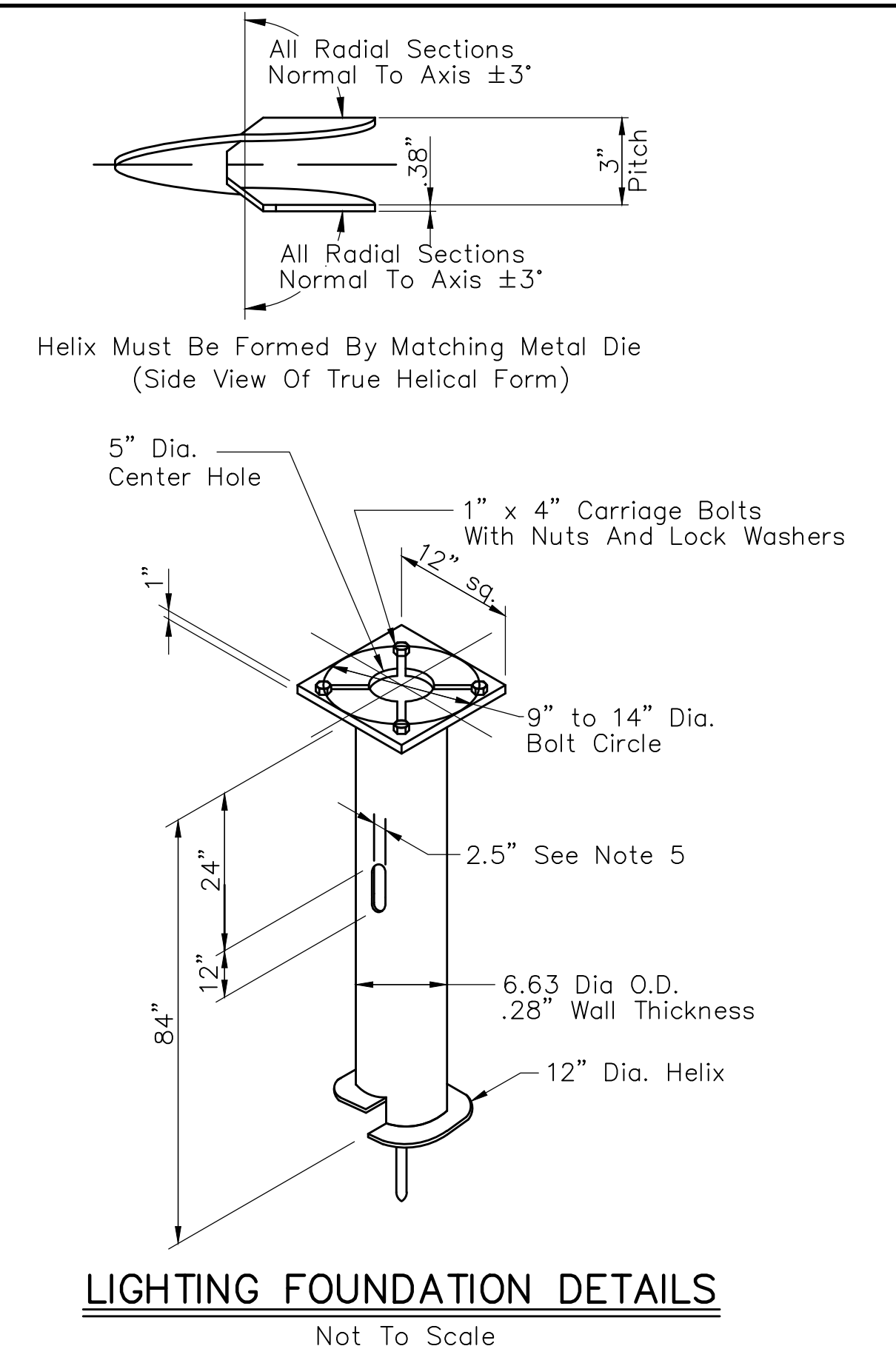

**TYPICAL LIGHT POLE DETAILS**  
Not To Scale

REVISIONS		
Rev. No.	Description	Date

DAVID LAHEY  
REGISTERED PROFESSIONAL ENGINEER  
No. PE19700063  
STATE OF INDIANA

RECOMMENDED FOR APPROVAL: *David Lahey* DESIGN ENGINEER, 01/01/2019 DATE

APPROVED: *Samuel...* TOWN ENGINEER, 01/01/2019 DATE

APPROVED: *John...* DIRECTOR OF TRANSPORTATION, 01/01/2019 DATE

TOWN OF PLAINFIELD

STREET LIGHTING DETAILS APPLICABLE TO COLLECTORS & ARTERIALS

SHEET 23 OF 25

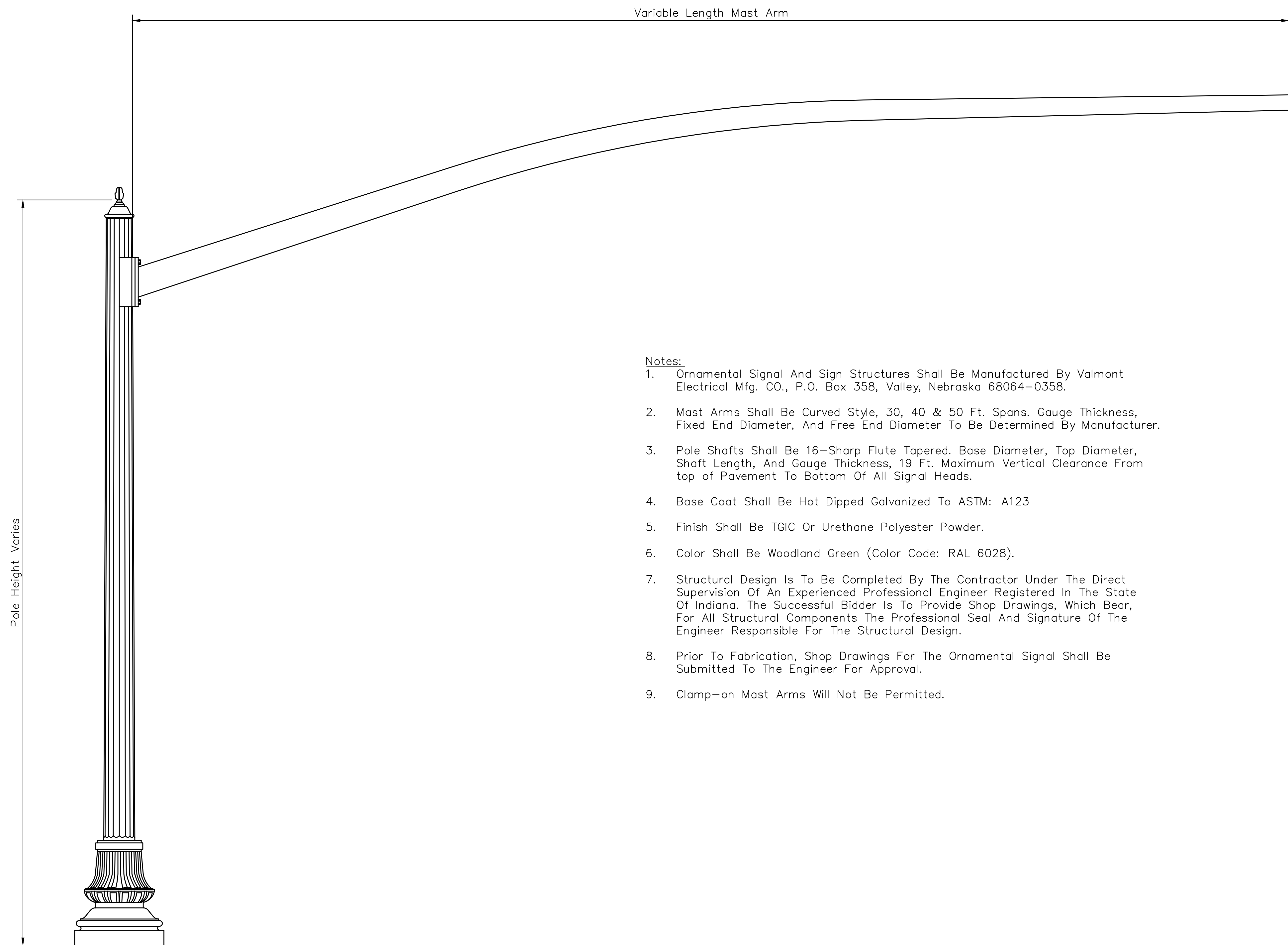

Notes:

1. Ornamental Signal And Sign Structures Shall Be Manufactured By Valmont Electrical Mfg. CO., P.O. Box 358, Valley, Nebraska 68064-0358.
2. Mast Arms Shall Be Curved Style, 30, 40 & 50 Ft. Spans. Gauge Thickness, Fixed End Diameter, And Free End Diameter To Be Determined By Manufacturer.
3. Pole Shafts Shall Be 16-Sharp Flute Tapered. Base Diameter, Top Diameter, Shaft Length, And Gauge Thickness, 19 Ft. Maximum Vertical Clearance From top of Pavement To Bottom Of All Signal Heads.
4. Base Coat Shall Be Hot Dipped Galvanized To ASTM: A123
5. Finish Shall Be TGIC Or Urethane Polyester Powder.
6. Color Shall Be Woodland Green (Color Code: RAL 6028).
7. Structural Design Is To Be Completed By The Contractor Under The Direct Supervision Of An Experienced Professional Engineer Registered In The State Of Indiana. The Successful Bidder Is To Provide Shop Drawings, Which Bear, For All Structural Components The Professional Seal And Signature Of The Engineer Responsible For The Structural Design.
8. Prior To Fabrication, Shop Drawings For The Ornamental Signal Shall Be Submitted To The Engineer For Approval.
9. Clamp-on Mast Arms Will Not Be Permitted.

DECORATIVE TRAFFIC SIGNAL POLE

Not To Scale

REVISIONS		
Rev. No.	Description	Date

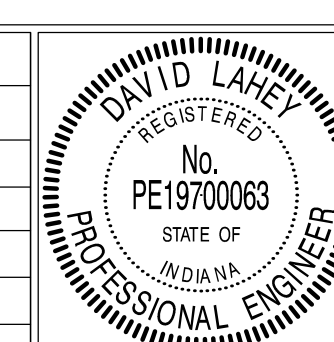

RECOMMENDED FOR APPROVAL	<i>David Lahey</i>	DESIGN ENGINEER	01/01/2019
APPROVED	<i>Samuel...</i>	TOWN ENGINEER	01/01/2019
APPROVED	<i>John...</i>	DIRECTOR OF TRANSPORTATION	01/01/2019

TOWN OF PLAINFIELD  
 TRAFFIC SIGNAL DETAILS  
 APPLICABLE TO COLLECTORS &  
 ARTERIALS

SHEET  
 24  
 OF  
 25

**LEGEND**

- ← 1-way, 3 Section (12" Red, 12" Amber, 12" Green) Signal Indication (Polycarbonate Only) W/ Back Plate
- T5-2 Cabinet On Type "P-1" Foundation
- Steel Strain Pole And Foundation, 30 Ft
- 2" Conduit
- Proposed Handhole
- Span Mount Junction Box
- Span Mounted Sign
- ⌘ Wireless Receiver Processor
- ⌘ Accessible Pedestrian Signal Module And Push Button W/R10-3E Sign And Countdown Pedestrian Signal Head
- Wireless Vehicle Magnetometer Detector
- ⊙ Service Point
- 2" Conduit, W/Tracer Wire, For CAT6 And/Or Fiber

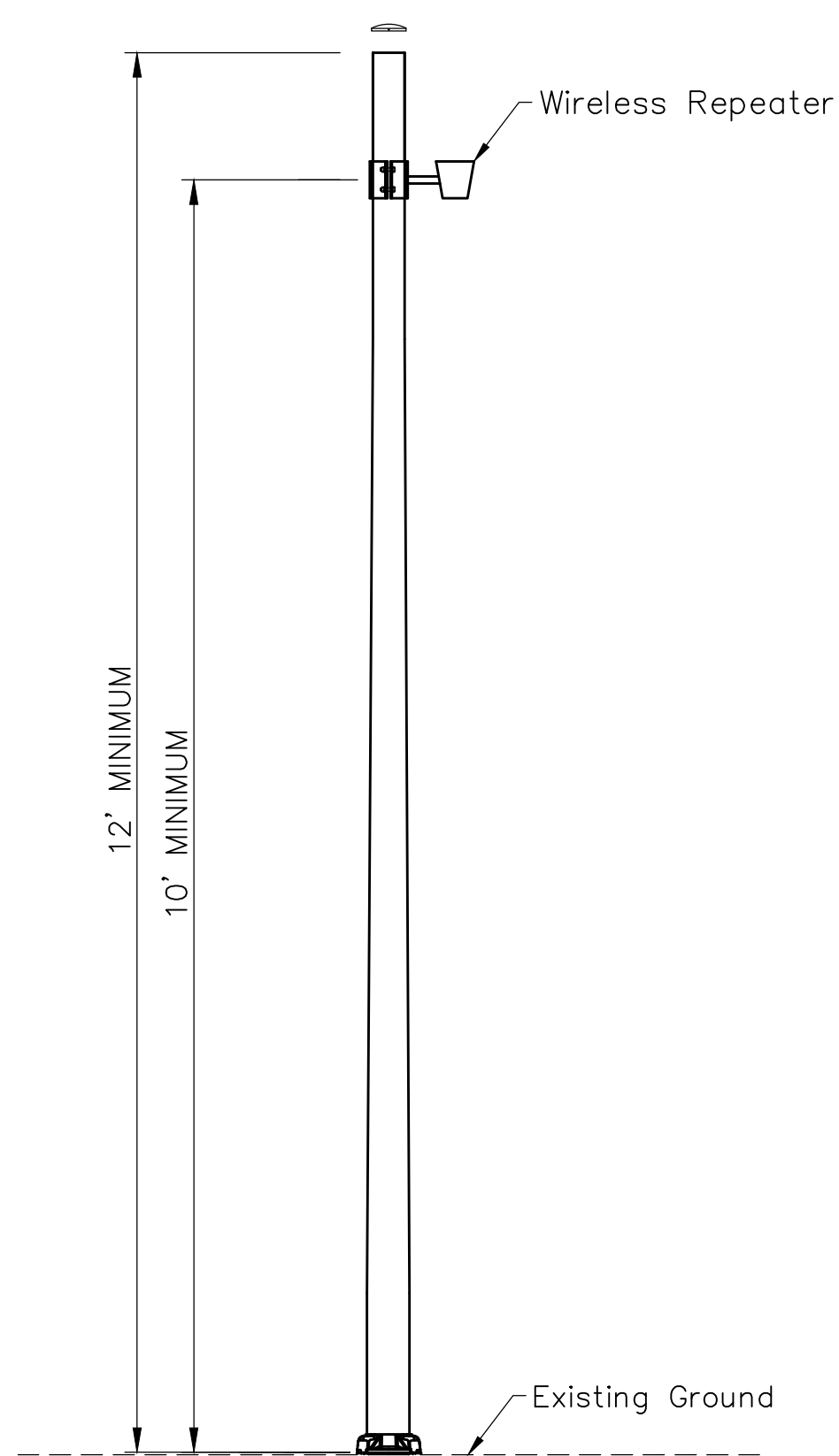

**TYPICAL REPEATER POLE MOUNT DETAILS**  
Not To Scale

**Notes:**

1. The wireless vehicle detection system shall be sensys.
2. Back Detection Shall Be Used For All Approaches 35 MPH In Accordance With The Indiana Design Manual And In Locations Approved By The Engineer.
3. Wireless Repeaters Not Designated On The Plans For Mounting On Steel Strain Poles Shall Be Mounted To An Aluminum Pole At Locations Approved By The Engineer.
4. The Pole Shall Be In Accordance With ASTM C 241 For Seamless Aluminum Alloy, Schedule 40, 6061-T6. The Outside Diameter Of The Pole Shall Be 4", Have A Unit Weight Of Approximately 3.7 LBS./Ft, And Have A Spun Finish.
5. A Pole Cap Shall Be Supplied For The Top Of The Pole. The Pole Cap Shall Be Spun Aluminum In Accordance With ASTM B 209, Alloy 1100-0.
6. All Hardware For Connection Of Repeater To The Pole Shall Be Stainless Steel.
7. The Pole Shall Be Installed Plum On An INDOT Type A Foundation.
8. Prior To Fabrication, Shop Drawings Shall Be Submitted To The Engineer For Approval.
9. Color Shall Be Woodland Green (Color Code: RAL 6028).

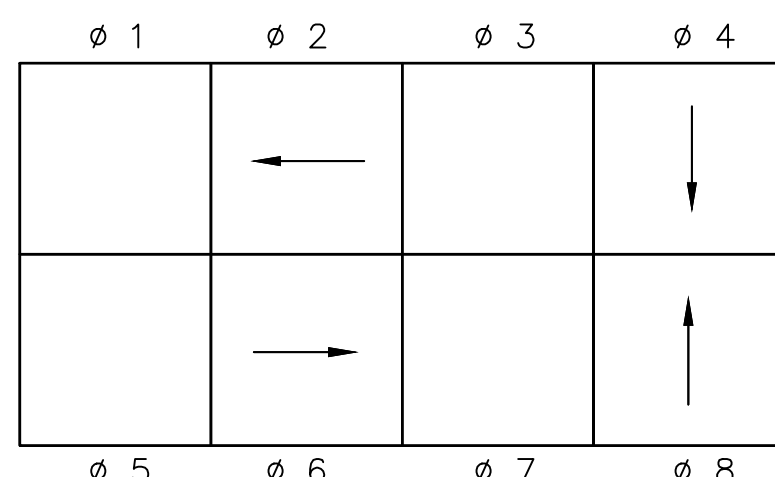

**PHASE DIAGRAM**

No Preferentially  
All Red Flash

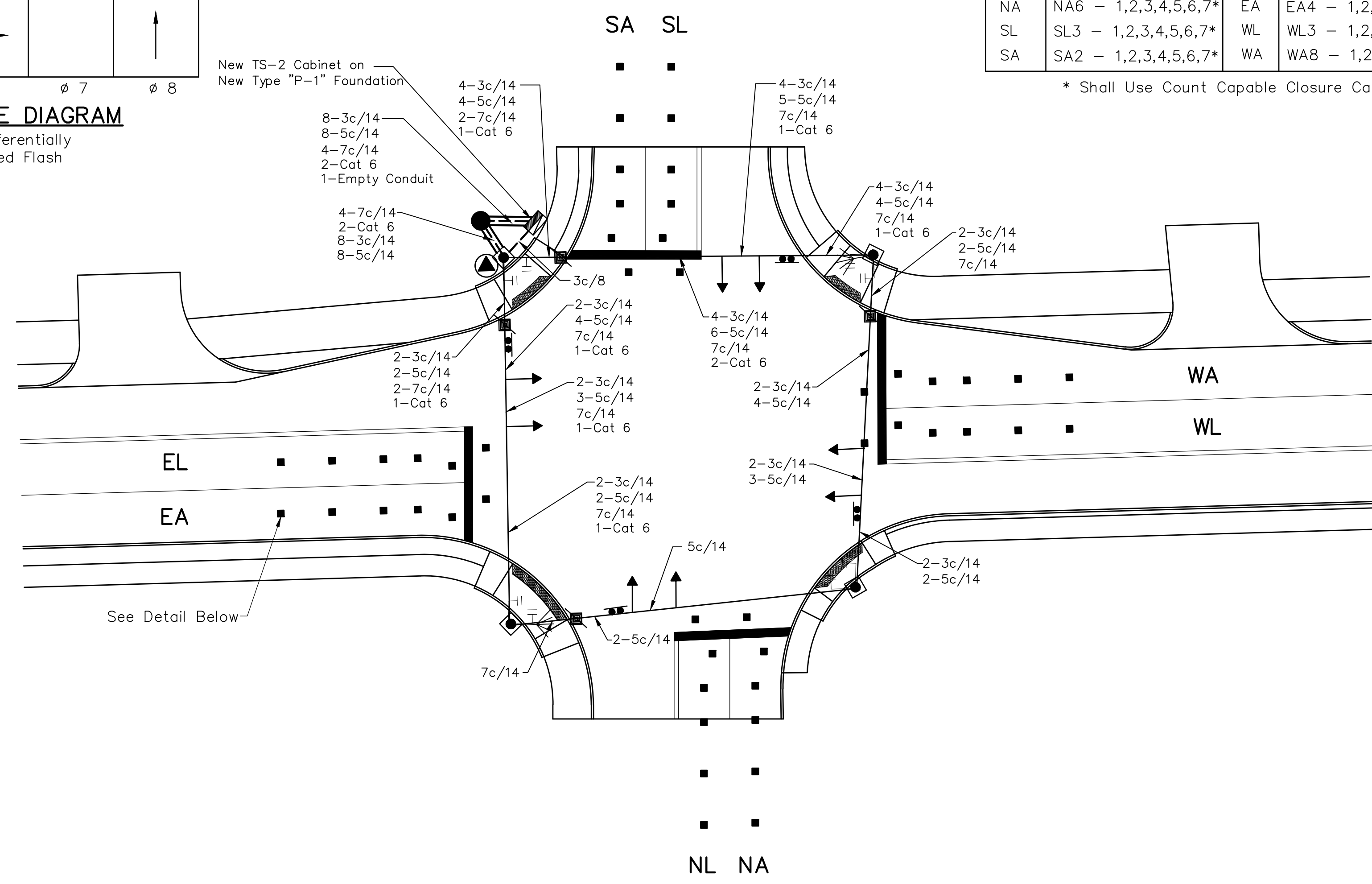

**SIGNALIZATION DETAILS**

Not To Scale

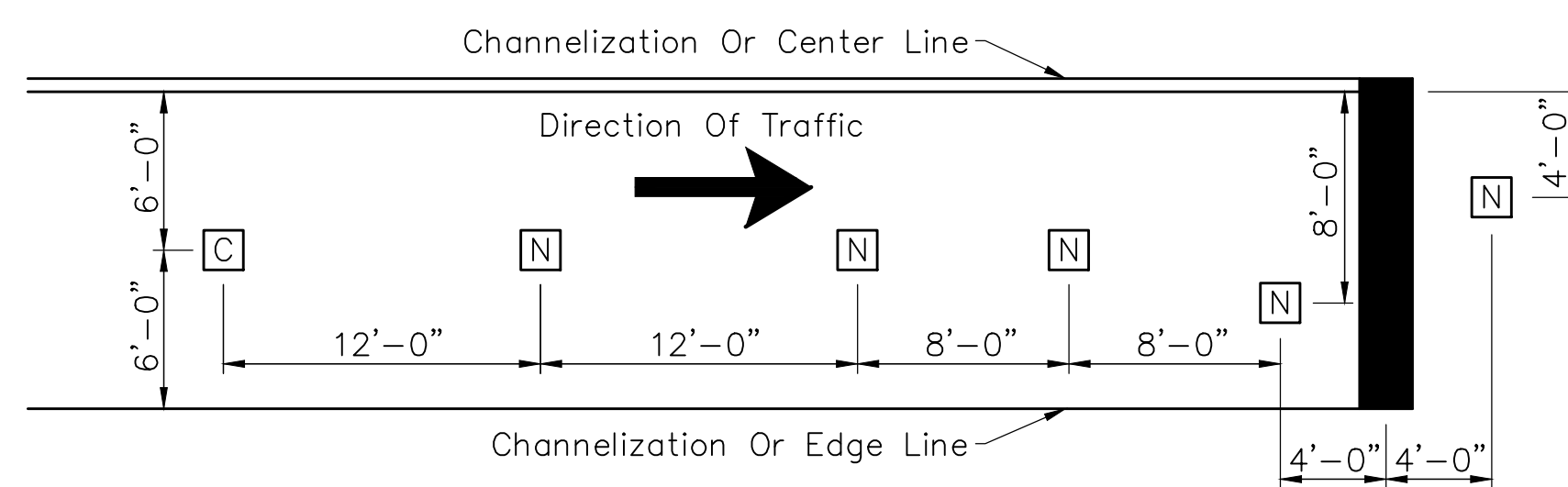

**WIRELESS VEHICLE DETECTOR DETAILS**

Not To Scale

**Notes:**

1. Type N Sensors Detect Only Vehicle Presence.
2. Type C Sensors Detect Vehicle Presence And Provide Vehicle Counts.
3. There Should Be At Least 1/4" And No More Than 1/2" Of Clearance Between The Top Of The Sensor And The Top Of The Pavement.

DETECTOR TAG TABLE			
LANE	TAG NUMBER	LANE	TAG NUMBER
NL	NL1 - 1,2,3,4,5,6,7*	EL	EL3 - 1,2,3,4,5,6,7*
NA	NA6 - 1,2,3,4,5,6,7*	EA	EA4 - 1,2,3,4,5,6,7*
SL	SL3 - 1,2,3,4,5,6,7*	WL	WL3 - 1,2,3,4,5,6,7*
SA	SA2 - 1,2,3,4,5,6,7*	WA	WA8 - 1,2,3,4,5,6,7*

\* Shall Use Count Capable Closure Card

REVISIONS		
Rev. No.	Description	Date

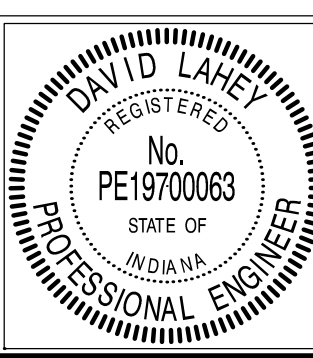

RECOMMENDED FOR APPROVAL: *David Lahey* DESIGN ENGINEER 01/01/2019 DATE

APPROVED: *Samuel...* TOWN ENGINEER 01/01/2019 DATE

APPROVED: *Jana...* DIRECTOR OF TRANSPORTATION 01/01/2019 DATE

TOWN OF PLAINFIELD	SHEET 25 OF 25
WIRELESS DETECTION DETAILS	